



Citation for published version:

Muelaner, JE & Maropoulos, PG 2010, 'Design for measurement assisted determinate assembly (MADA) of large composite structures', Journal of the Coordinate Metrology Systems Conference.

Publication date:
2010

[Link to publication](#)

University of Bath

General rights

Copyright and moral rights for the publications made accessible in the public portal are retained by the authors and/or other copyright owners and it is a condition of accessing publications that users recognise and abide by the legal requirements associated with these rights.

Take down policy

If you believe that this document breaches copyright please contact us providing details, and we will remove access to the work immediately and investigate your claim.

Title of the CMSC White Paper: Design for Measurement Assisted Determinate Assembly (MADA) of Large Composite Structures
Author(s) Name(s)/Company(s): J E Muelaner, P G Maropoulos
Contact information for submitting Author:
Name, Company J E Muelaner, The University of Bath
Address, Town, Zip Bath, BA2 7AY, UK
Phone Number: +44 (0) 7743 845 124
Email: j.e.muelaner@bath.ac.uk
Word Count:
Number of Images Submitted:

Abstract: This paper describes how Measurement Assisted Determinate Assembly (MADA) can facilitate the lean production of aerospace structures, provided that the structure is designed for MADA. A novel wingbox design and production process is used to illustrate this. The aerospace industry has not benefited from the significant reductions in production cost and cycle time that can result from greater assembly efficiency, part-to-part interchangeability and the use of flexible automation. This is largely due to the very high accuracies required across large scale assemblies. The use of metrology can reduce process steps, reduce the reliance on costly hard tooling, reduce the requirement for manually intensive and time consuming re-working at late stages of assembly, and allow low cost flexible automation to place tools to the required accuracies. The generic MADA process is presented together with guidelines for the design of structures to enable MADA.

1 INTRODUCTION

The mode of production for aerospace structures can best be understood in the context of the development of manufacturing in general. Historically manufacture involved craftsmen carrying out a wide range of operations using general purpose tools. Division of labour has been understood since antiquity [1] and by the 18th century was enabling unskilled workers carrying out highly repetitive tasks to produce products that would previously have required skilled craftsmen [2]. Machine parts however continued to be filed to fit to one another by skilled fitters until the 19th Century [3].

Developments of 19th Century small arms manufacturers allowed semi-skilled workers to produce interchangeable parts which could be simply assembled without reworking. Key developments were single use automated machines carrying out successive operations on parts and the use of jigs, fixtures and gauges, designed with reference to a single physical 'master' model of the product [4]. Mass production was a natural progression of the armoury practice with the duration of successive operations reduced, products designed for simple assembly and a moving assembly line. Assembly workers on this type of line generally do not require any particular skill but they can not then be expected to gauge parts or improve the production system, additional foremen and production engineers are therefore required; additional staff who do not directly add value to the product.

From the 1820's through to 1927 there was a steady progression away from the complete generality of craftsmen and their tools and towards the ever increasing specialisation of both machinery and of manual operators. In 1927 the limitations with this approach became apparent as Ford experienced enormous difficulty in switching production over from the Model T to the Model A. In the same year Chevrolet began developing flexible mass production with flexible standard machines allowing regular incremental changes to be easily accommodated; by 1929 when the major change from four to six cylinders was implemented, this took only 3 weeks [4].

Lean production takes flexible mass production a stage further with highly flexible machines which can be reconfigured in minutes rather than days allowing small batch production. Lean is however more than highly flexible mass production; it also involves tasks and responsibilities being transferred down the organisational tree to the people actually adding value to the product. The assembly workers themselves are responsible for quality control, finding the cause of any issues and improving the production system [3]. Only 'Tier 1' suppliers deal directly with the final assembler and are responsible for managing 'Tier 2' suppliers as well as the design of complete sub-systems. Lean reintroduces the flexibility and quality ownership of craft production while maintaining the efficient operations of mass production.

The production of large aerospace assemblies is often characterized by the inefficiency of craft production; craftsmen fettling or shimming parts to fit and carrying out a wide variety of highly skilled operations using general purpose tools. Reliance on monolithic jigs is of further detriment to the assembly as one of the advantages of craft based manufacture, flexibility, is also not achieved since the jigs are highly inflexible, costly and have long lead times. Approximately 5% of the total manufacturing cost of an aircraft [5] or 10% of the airframe [6] is related to the use of fixed tooling. The highly skilled

workforce is however able to carry out quality control and continuous improvement. Where manual craft based operations are automated it is often using inflexible, single use machines.

It could be said that the production of large aerospace assemblies combines the inefficiency of craft production with the inflexibility of the early forms of mass production. This is clearly an issue, but why is such an inefficient mode of production used? It is not due to a lack of competence, awareness of the issues or willingness to embrace new technologies; the aerospace industry benefits from access to many of the best minds in engineering and is well known for utilizing the latest technologies in many areas.

The root causes are the difficulties in maintaining very close tolerance requirements over large structures and the large number of different operations for relatively low production volumes. Issues related to maintaining high tolerances are the biggest challenges; the light weight aero structure has flexible components; interfaces are often imprecise especially for composite components; and it is very difficult to drill patterns of holes in different components which will match and lock the assembly into its correct overall form. The current solution to these issues is to use a monolithic jig which holds flexible components to their correct final form as the assembly is built-up, interface gaps are then measured in the jig so that shims can be fitted and holes are drilled through the stack of components. It is then necessary to break the assembly apart to debur holes, clean and apply sealant before the final assembly takes place [7, 8]. This process results in additional process steps, inflexibility due to reliance on monolithic jigs and inefficient craft based production due to high levels of reworking in-jig. Additionally, the variety of operations at low volumes combined with the high tolerances required makes it very difficult to automate processes. Further increasing the number of craft based processes required while maintaining close tolerances means that where automation is used, it is generally based on inflexible gantry systems. The way in which the root causes result in assembly issues and ultimately inefficient modes of production is illustrated in Figure 1 which is contrasted against an alternative approach to dealing with these issues illustrated in Figure 2.

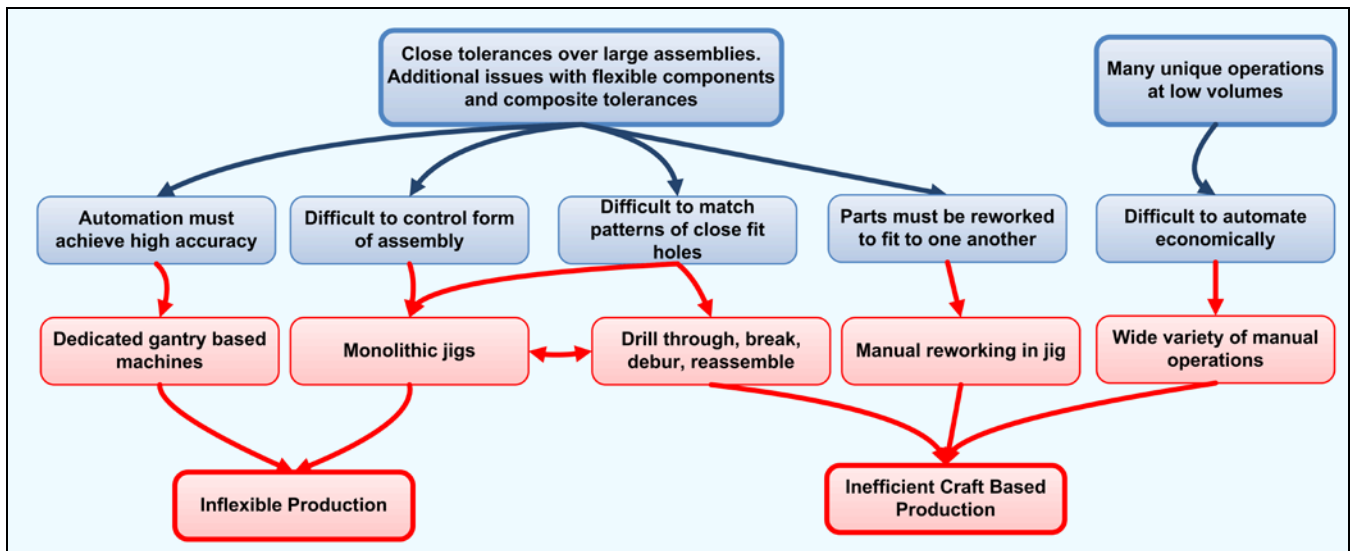

Figure 1: Root Causes of Inefficient Modes of Production used in Aerospace Assembly

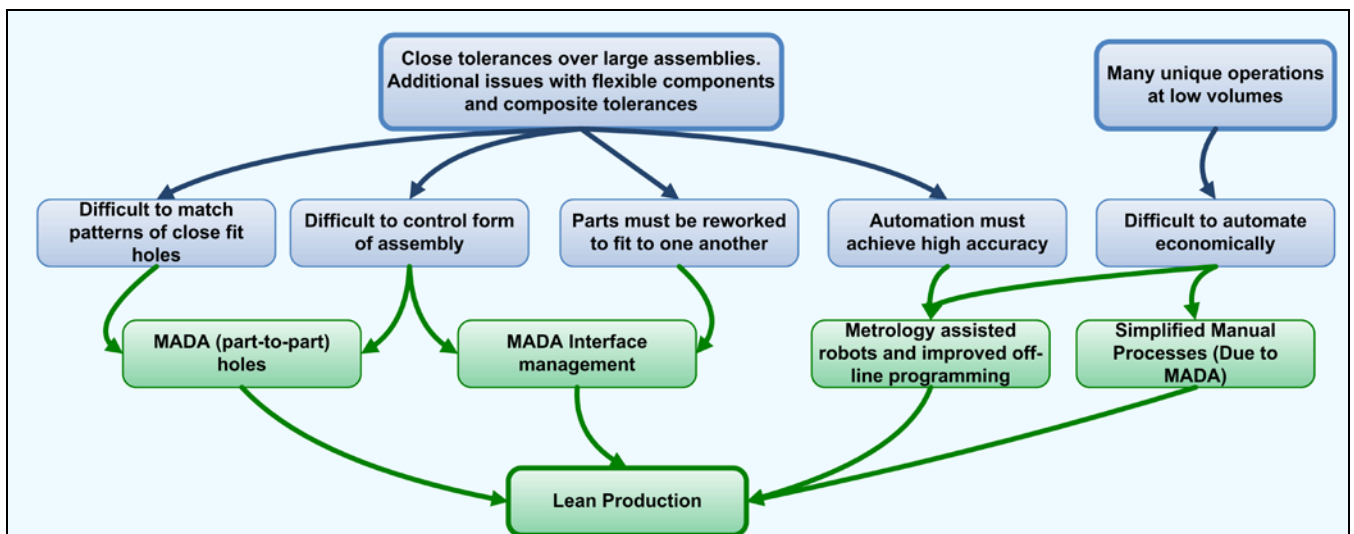

Figure 2: Alternative Method for Addressing issues in Aerospace Assembly Leading to Lean Production

If interfaces could be fettled or shimmed, and hole patterns drilled during component manufacture, then it would be possible to create a determinate assembly in which the component interfaces would determine the final form of the assembly and therefore no jig or accurate fixture would be required. It will be explained in the following section that achieving this type of part-to-part assembly does not necessarily require full interchangeability tolerances to be achieved. If these part-to-part processes are adopted, simplified manual assembly processes could be used in place of the current craft based processes.

Industrial robots are typically able to repeat operations with much greater precision than the accuracy with which they are able to position themselves when programmed to move to specific coordinates [9]. It is therefore possible to manually ‘teach’ a robot to carry out accurate operations, although this approach is time consuming and therefore not practical for large numbers of different operations which will only be repeated for limited production volumes. Off-line programming [10] has the potential to rapidly programme robots to carry out many operations based on a digital virtual product and factory model, although currently these systems also require considerable time. In order for these off-line programmes to deliver accurate robotic operations, the robot must have improved accuracy which can be delivered through some form of closed loop control from a metrology system [9, 11]. Metrology assisted robots and improved off-line programming might therefore facilitate an increased use of flexible automation despite the large number of unique operations at low volume.

2 ACHIEVING PART-TO-PART HOLES AND INTERFACES

The main focus of this paper is the adoption of part-to-part holes and interfaces to facilitate the lean assembly of aerospace structures. It may at first seem that achieving this part-to-part assembly requires interchangeability tolerances to be achieved across the assembly; something that is unlikely to be economical. It is however possible, through the application of measurement assisted processes and design for manufacture, to economically produce all of the large components with relatively slack tolerances and still achieve part-to-part. This is the essence of MADA.

The principle of measurement assisted processes allowing part-to-part with relaxed tolerances can be illustrated using a simple two dimensional example. Firstly, considering a localized pattern of holes as illustrated in Figure 3,

If hole diameters are greater than the fastener diameter, a degree of ‘float’ between two matching holes is possible with the fastener still passing through both holes. A simple pattern of two holes as shown in Figure 3 can then be used to derive the required positional accuracy of holes. If the maximum condition of each hole float is utilized to allow the fasteners to pass through the holes then this determines the required accuracy, as shown in Figure 3.

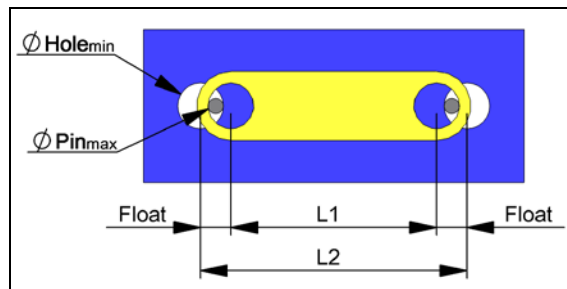

Figure 3: Matching Two Components with a Pattern of Two Holes

$$\text{Float} = \text{Hole}_{\min} - \text{Pin}_{\max} \quad (1)$$

Assuming a nominal diameter of less than 10 mm and a close clearance location fit the minimum hole diameter (H8) is equal to the nominal diameter and the maximum pin diameter (f7) is 13 μm less than the nominal [12]. Considering Equation (1) the float in each hole is therefore 13 μm and by propagating the tolerances statistically (not worst case) it can be shown that each hole must also be located to within 13 μm to ensure that the hole patterns will match. Hole positioning to this accuracy is within the specification of a standard industrial milling machine [13] and it is perhaps not surprising that achieving part-to-part holes across patterns of up to a couple of metres is not especially challenging.

Achieving part-to-part holes across larger assemblies is more challenging, for example consider the arrangement shown in Figure 4 which could represent the hinge-line brackets of an aircraft wingbox. Within each local hole pattern attaching a single bracket to the base part, holes must be positioned within 13 μm as shown above, while each bracket must be positioned on the base part to within 100 μm .

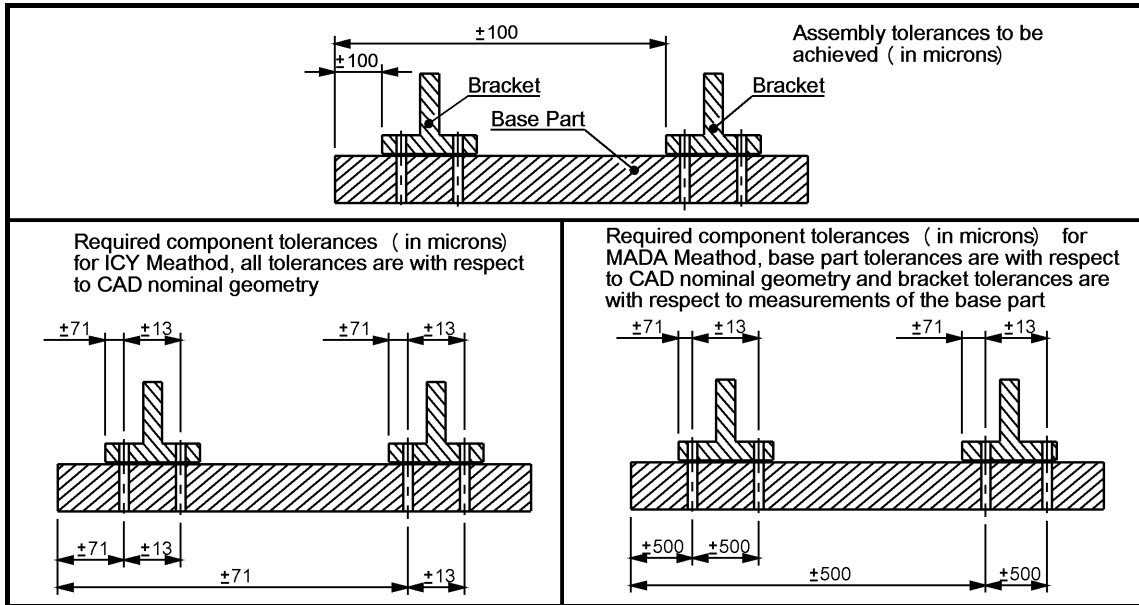

Figure 4: Example Assembly Showing Differing Tolerance Requirements for Interchangeability (ICY) and MADA

Applying the conventional interchangeability approach to achieving part-to-part assembly all of the holes must be drilled to within 13 μm of other holes within the same local pattern and each hole pattern must be globally located on the spar to within 71 μm . Since the spar is several metres long this would be both challenging and costly requiring a very large and highly accurate drilling machine.

An alternative approach used in the MADA process is to place the holes in the spar to a considerably slacker tolerance, perhaps to 0.5 mm using a standard industrial robot mounted on a linear guide way as shown in Figure 5. The hole positions can subsequently be *measured* to the more demanding positional accuracies of 13 μm locally and 71 μm globally so that the measured positions can be supplied to a standard CNC machine tool which can then drill the corresponding holes in the brackets.

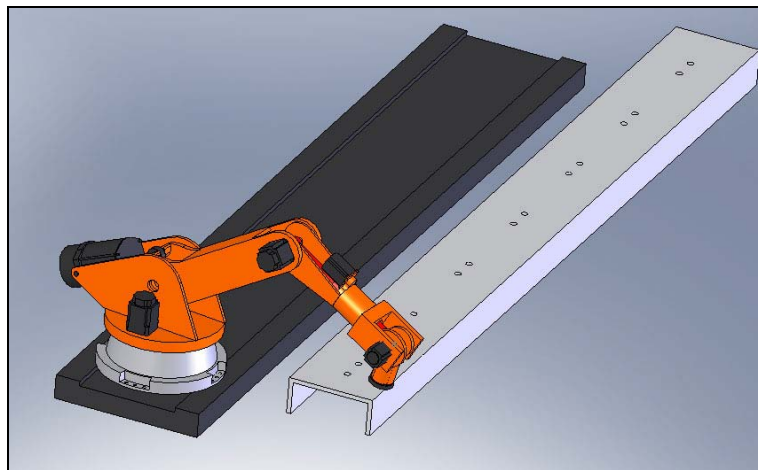

Figure 5: Industrial Robot on Linear Guide Drilling Low Accuracy Holes in Spar

Although the MADA approach removes the requirement to position holes accurately on large parts, measuring the hole positions to these accuracies presents its own challenges, discussed below.

The same principles explained above with reference to holes can also be applied to surface profiles at interfaces. Just as hole positions in large components do not need to be tightly controlled provided they can be accurately measured, the surface profiles in regions interfacing with smaller components can also have relaxed tolerances. This principle has been previously published by Airbus UK in relation to the forming of rib feet to measurements of the internal surface of wing box covers. Two processes have been suggested [14], machining rib feet to cover measurements [15] and *predictive shimming* in which the interfacing surface profiles of two components are measured and a bespoke shim is then produced using additive layer manufacturing (ALM) [16]. A similar process, also utilizing additive layer manufacturing to produce a shim is being developed by Boeing [17].

A novel approach to the forming of bespoke interfaces is suggested here. The approach described above involves using measurement data characterizing the interface surface on a large component to produce a matching shim component via

ALM. It would also be possible however to use the measurement data to produce a negative of the required interface, this negative could then be inserted into a mould tool to produce a structurally integral bespoke interface on a composite part using the established resin transfer moulding (RTM) technique. This process will be referred to as Adaptive Resin Transfer Moulding (ARTM).

2.1. KEY ASSUMPTIONS AND CONSTRAINTS

The central assumption made by the MADA approach is that achieving the very high accuracies required for part-to-part holes and interfaces over the full scale of aerospace structures is unlikely to become an economical approach while measuring the holes and interfaces will become increasingly cost effective. Some general observations concerning the production of composite components are also of particular interest:-

- Large components with dimensions of several metres plus are produced using open mould techniques. The surface in contact with the mould is known as the Outer Mould Line (OML) and is controlled to tight tolerances; the surfaces not in contact with the mould tool are known as the Inner Mould Line (IML) and have tolerances of millimetres.
- Complex parts can be built-up from multiple parts bonded together such as a skin and stringer structure. This is normally done with successive parts added to a single mould tool.
- Smaller components with dimensions of up to a few metres can be produced with tight tolerances and good surface finish on all surfaces using closed mould techniques such as Resin Transfer Moulding (RTM). It is also relatively easy to machine bespoke interfaces on these smaller parts.

2.2. MEASUREMENT ASSISTED DETERMINATE ASSEMBLY

The way in which the Measurement Assisted Determinate Assembly (MADA) approach allows part-to-part assembly with relaxed tolerances is described above. It was acknowledged that the principle of forming an interface on one component to measurement data of another component is not entirely new with a number of specific applications being developed by the major aircraft manufacturers. MADA is however novel in giving a complete and generic set of design principles and production techniques to facilitate cost effective and high quality production, especially of composite structures. The fundamental principle of MADA is that large components can be economically produced with inaccurate interfaces and hole positions, and they can then be accurately measured. Bespoke smaller components can subsequently be produced to high accuracy with respect to these measurements. The complete assembly can then be put together simply with part-to-part holes and interfaces facilitating determinate assembly.

The full benefits of MADA require that a structure is designed according to certain principles; it can not be readily applied as a production solution for existing designs. The key design principles are:-

- Large components should be designed to interface with each other OML-to-OML where tolerances allow.
- Large thin components should have stiffening components (stringers and ribs) added to form sub-assemblies suitable for determinant assembly of the main structure. These sub-assemblies may be built while the main panel component remains in its open mould.
- Where components must interface with the IML of a large component the smaller components must make this interface. The IML of the large component should be scanned while the component remains in its mould tools. The smaller components can then be formed to fit using either conventional machining or a proposed 'Adaptive RTM' process explained above.
- It is not necessary to place all holes in large components to the tolerances required for determinant assembly. Where it is beneficial tolerances should be relaxed and the hole positions then measured so that mating parts can have holes placed in corresponding positions.

There has been some interest in Measurement Assisted Assembly (MAA) and Jigless Assembly. It is important to note that although the jigless approach does not rely on jigs to place tools for operations such as drilling there is still a requirement for monolithic fixtures to control the form of the assembly. These processes essentially mirror the conventional build process but reduce the complexity of tooling required and automate some of the manual processes with an increased use of flexible automation. The MADA approach is a more radical departure from the conventional aerospace assembly process with greatly reduced process steps, no requirement for monolithic tooling solutions and almost all of the work being carried out at the component manufacturing stage to allow rapid assembly. Figure 6 compares the three processes in detail and clearly shows the greatly simplified process enabled by MADA.

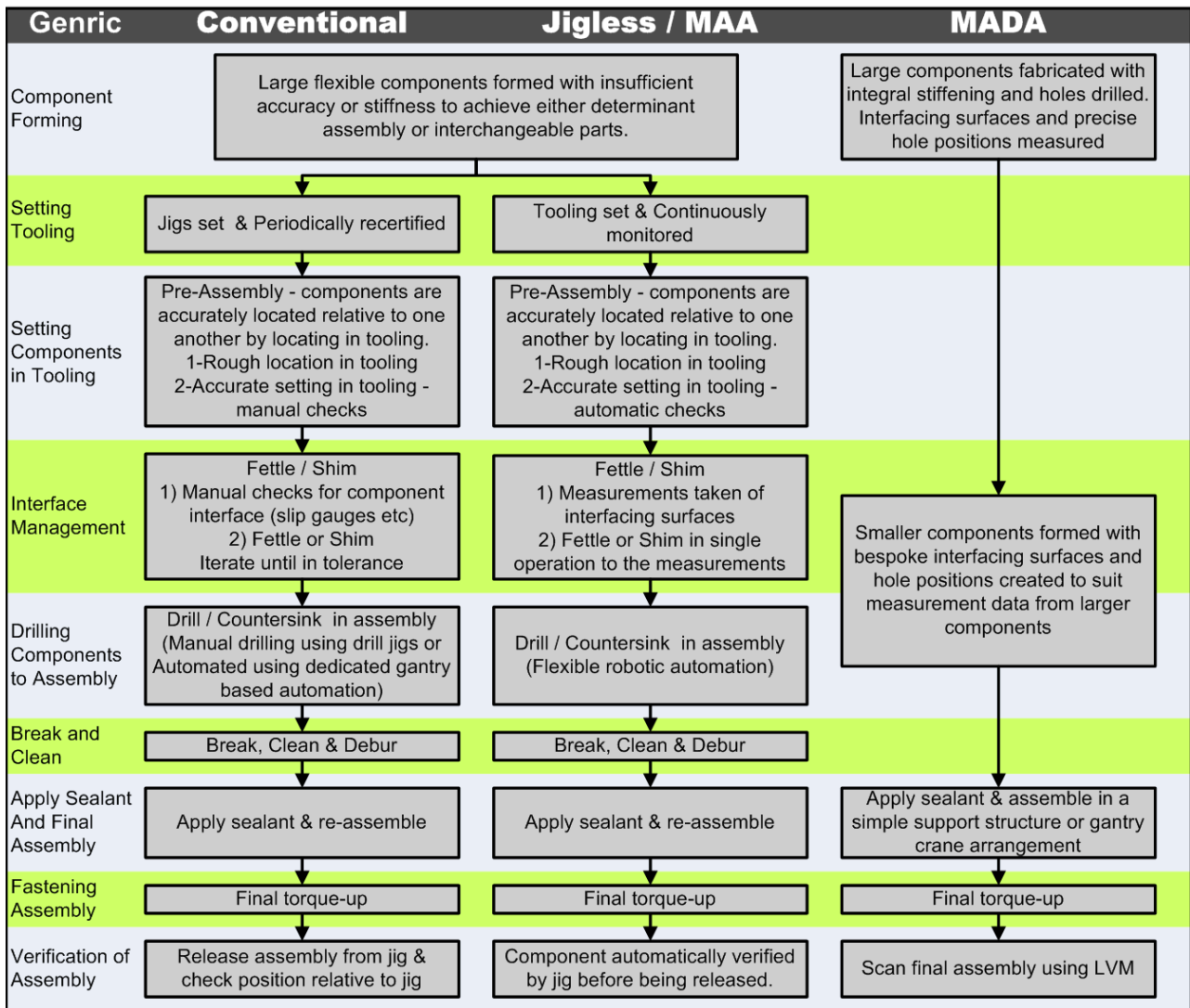

Figure 6: Comparison of Three Generic Aerospace Assembly Processes

2.3. METROLOGY CAPABILITY REQUIRED FOR MADA

The MADA process requires a very high accuracy of measurements for hole locations and surface profiles; to approximately 10 μm within 1 metre zones and to 50 μm within zones 10's of metres long. This will present significant challenges for metrology. The Etalon laser tracker system represents the state of the art in large volume traceable metrology, it is able to track a target probe to accuracies of less than 10 μm over a 10 m length [18]. This demonstrates that the required accuracies are achievable although achieving them would likely require a temperature controlled environment. The use of this instrument is unlikely to be practical for this application however since it would require holes and surfaces to be physically probed while the probe is tracked from multiple locations by the laser tracker instruments.

Photogrammetry typically uses circular retro-reflective targets for automated measurement in which algorithms identify the elliptical geometry and to best fit the image to the idealized ellipse allowing measurement of the target centroid with sub-pixel accuracy [19]. Target measurement accuracy of 20 μm over a 1 m length and 110 μm over 10 m are claimed by the manufacturer [20] which is not sufficient for the MADA process, although it is of the right magnitude. The direct measurement of holes is possible with the regular circular geometry of the drilled hole used in place of retro-reflective targets provided a sufficient contrast is achieved between the drilled component and the hole [21]. Targets must also be placed on to surfaces in order to characterize interface profiles but this can be automated using laser target projection allowing accuracies of 50 μm over a 5 m length [22].

Another potential solution would be the use of a laser tracker to locate a localized non-contact measurement device, potentially handled by a robotic arm. Although the interferometer accuracies for industrial laser trackers are well within the requirements of MADA the additional uncertainties introduced by non-contact measurement systems would mean that current system could not deliver the required performance. While the combined uncertainty for a contact probing system might approach the 10 μm requirement [23], for a non-contact system it would be of the order of 60 μm [24].

With such high accuracy requirements it also becomes vital that environmental effects are properly considered. For example the temperature of the parts when being measured and worked on must be considered so that measurements can be scaled for thermal expansion.

3 EXAMPLE MADA PROCESS APPLIED TO A NOVEL WINGBOX DESIGN

The conventional wingbox structure consists of ribs which span the gap between the upper and lower cover and channel section spars as shown in Figure 7. This structure is not suitable for MADA since the large components do not interface with one another OML-to-OML, in particular the spar interfaces with the IML of the cover. Additionally, since the ribs span the gap between the covers it is not possible to join the ribs to the covers at the subassembly stage and the covers therefore remain flexible until the final assembly.

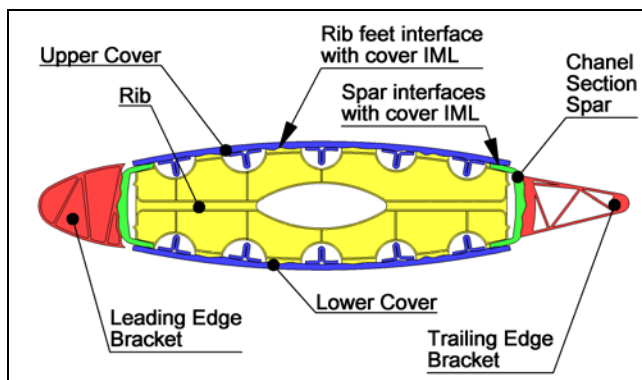

Figure 7: Conventional Wingbox Structure

There have been attempts to design a wingbox structure that is more suited to manufacture, particularly from the perspective of tolerance management. Of particular note is a concept wingbox in which half ribs are attached to each of the upper and lower covers forming rigid sub-assemblies which can then be joined together [25] as shown in Figure 8.

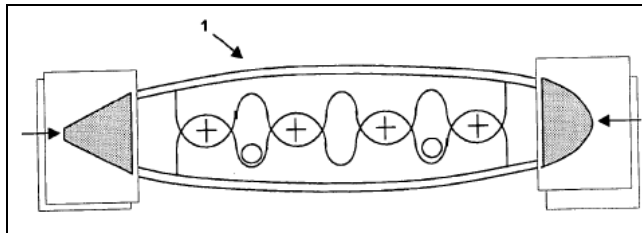

Figure 8: Wingbox Concept with Half Ribs [25]

Another interesting concept is the channel section wingbox with spars and lower cover integrated into a single composite structure which has been developed by the Japan Aerospace Exploration Agency (JAXA) [26] and which is illustrated in Figure 9. This design is however not well suited for MADA since where this large integrated structure interfaces with the upper cover there is a large flexible component interfacing at the IML with another large component.

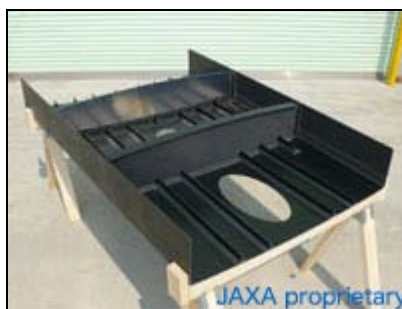

Figure 9: Channel Section Integrated Cover and Spars

A novel design is presented in the paper which applies the principles of design for MADA set out above. In this design the upper and lower cover is designed with a slight return at each edge to form a channel section, the ribs are split into upper and lower half ribs which are joined to the covers to form rigid sub-assemblies and the spars are simple flat members, as shown in Figure 10. This arrangement means that the OML of the covers is able to interface directly with the OML of the spars. It is anticipated that both the covers and the spars would be produced using some form of open mould fabrication and the returns

on the edges of the covers would therefore remain gently curving and not fully return to the vertical so as to allow removal from the mould tool. The ribs would require bespoke profiles to be machined where they interface with the IML of the cover and the brackets would also require bespoke profiles where they interface with the IML of the spars.

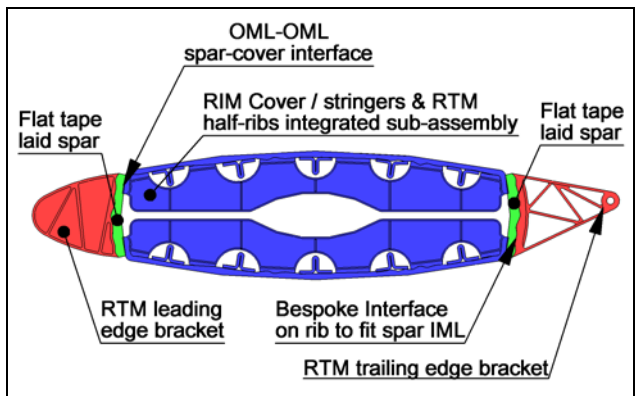

Figure 10: A Novel Wingbox Designed for MADA

The complete assembly process for the proposed MADA wingbox is illustrated in Figure 11. Solid black lines represent the flow of physical components from one assembly station to the next while red dashed lines represent the flow of measurement data between assembly stations.

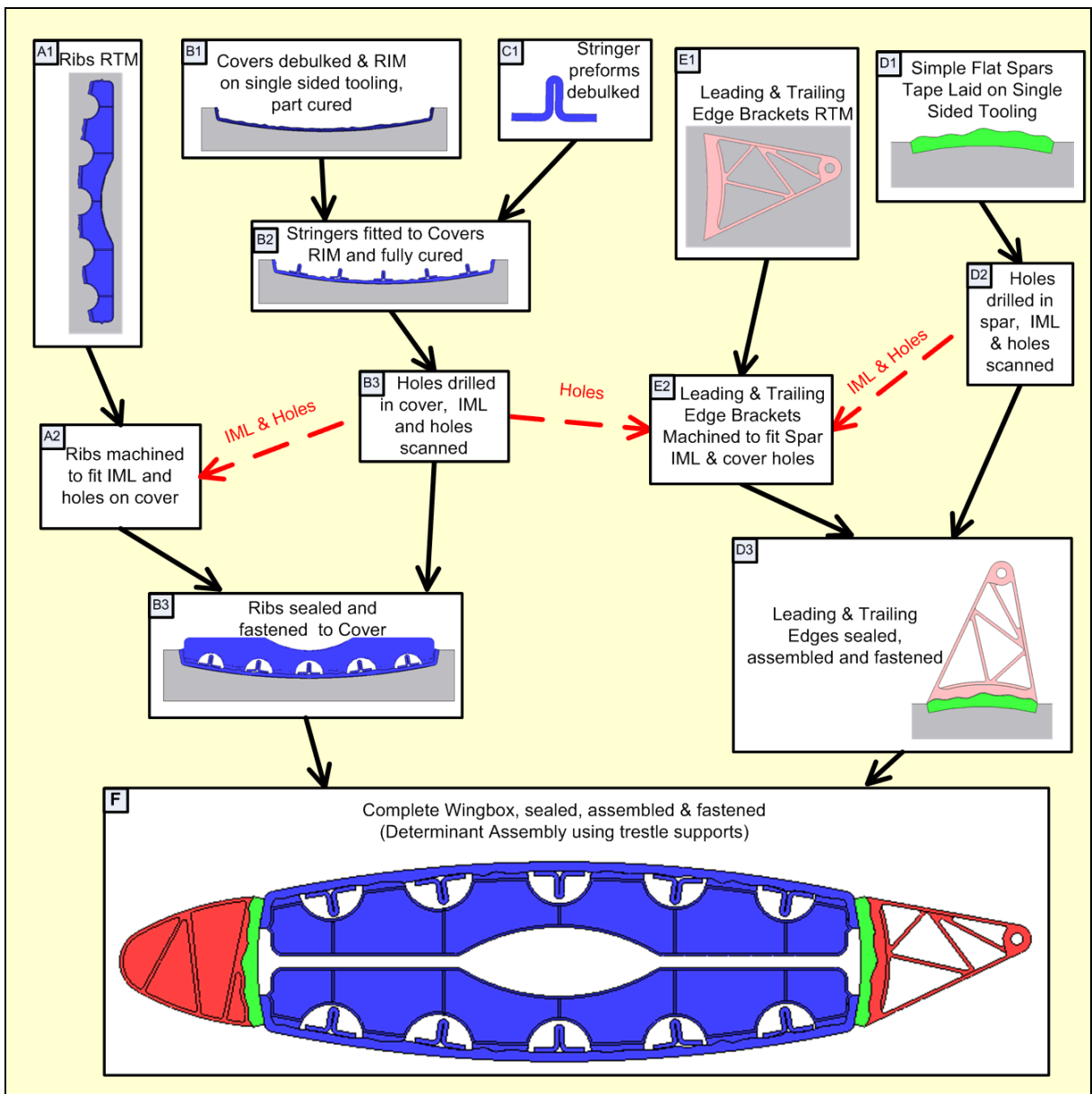

Figure 11: MADA Process for Novel Wingbox Design

It is important to note that there are part-to-part holes drilled in the brackets to fit to both the spar and to the covers. The holes which fit to the spars are standard. The holes which fit to the cover are not so straightforward since the spars are assembled between the covers and the brackets. It is therefore necessary to nominally place clearance holes in the spars to allow the fasteners to locate the brackets relative to the covers, as shown in Figure 12. The effect of this is that the tolerances for the holes in the bracket and spar will combine to determine the cover position and therefore the normal $50\ \mu\text{m}$ global hole position tolerance would need to be reduced to $50/\sqrt{2} = 35\ \mu\text{m}$.

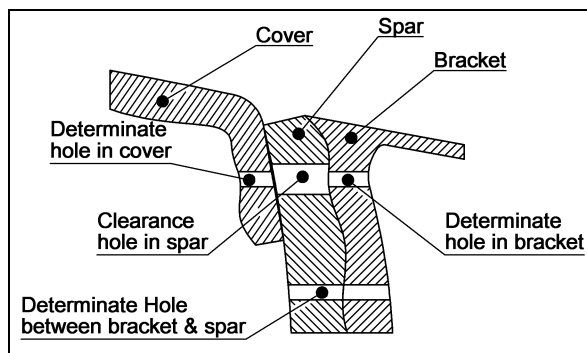

Figure 12: Hole Arrangement for Cover, Spar, Bracket Interface

The alternative would be to directly drill part-to-part holes in the leading and trailing edge assemblies at stage D3, again using the measurements made at stage B3. This would be a structurally more sound solution and likely to be preferable if bonding of components is not suitable as the main structural connection between parts. It would however require a large high accuracy drilling machine capable of maintaining tolerances of the order of $10\ \mu\text{m}$ hole position over 10's of metres, this is likely to present significant cost and technical challenge.

4 CONCLUSION

The measurement assisted determinate assembly (MADA) approach set out in this paper provides a clear strategy for the design and production of aerospace structures according to lean production principles. The assumption is made that the production of components to interchangeability tolerances will remain uneconomical but that highly accurate measurements will become increasingly affordable. Current industrial measurement systems are generally not able to deliver the required accuracies although photogrammetry has some potential and state of the art laser tracker systems do show that it is possible to achieve significantly better accuracy than is required for MADA. New aircraft currently in the early stages of design should be designed for MADA with the expectation that by the time these aircraft enter production, in perhaps 10 years time, it will be possible to achieve the measurement accuracy required for MADA.

ACKNOWLEDGEMENTS

The work has been carried out as part of the EPSRC, IdMRC at the Mechanical Engineering Department of the University of Bath, under grant No. EP/E00184X/1.

REFERENCES

1. Xenophon, *Cyropaedia: the education of Cyrus*. c400 BC.
2. Smith, A., *An Inquiry into the Nature and Causes of the Wealth of Nations*. 1776.
3. Womack, J.P., D.T. Jones, and D. Roos, *The Machine that Changed the World*. 1990: Rawson Associates New York.
4. Hounshell, D.A., *From the American System to Mass Production 1800-1932*. 1984, Baltimore: The John Hopkins University Press.
5. Rooks, B., *Assembly in aerospace features at IEE seminar*. *Assembly Automation*, 2005. **25**(2): p. 108-111.
6. Burley, G., R. Odi, S. Naing, A. Williamson, and J. Corbett. *Jigless Aerospace Manufacture - The Enabling Technologies*. in *Aerospace Manufacturing Technology Conference & Exposition*. 1999. Bellevue, Washington: Society of Automotive Engineers
7. Pickett, N., S. Eastwood, P. Webb, N. Gindy, D. Vaughan, and J. Moore. *A Framework to Support Component Design in Jigless Manufacturing*. in *Aerospace Manufacturing Technology Conference & Exposition*. 1999. Bellevue, Washington
8. Muelaner, J.E. and P.G. Maropoulos. *Large Scale Metrology in Aerospace Assembly*. in *5th International Conference on Digital Enterprise Technology*. 2008. Nantes, France
9. Summers, M. *Robot Capability Test and Development of Industrial Robot Positioning System for the Aerospace Industry*. in *AeroTech Congress & Exhibition*. 2005. Grapevine, Texas: SAE International

10. Yong, Y.F., J.A. Gleave, J.L. Green, and M.C. Bonney, *OFF-LINE PROGRAMMING OF ROBOTS*. 1985, John Wiley & Sons: New York, NY, USA. p. 366-380.
11. Muelaner, J.E., Z. Wang, and P.G. Maropoulos. *Concepts for and Analysis of a High accuracy and High Capacity (HAHC) Aerospace Robot*. in *The 21st International Computer-Aided Production Engineering Conference*. 2010. Edinburgh
12. BSI, *ISO system of limits and fits - Part 2: Tables of standard tolerance grades and limit deviations for holes and shafts*, in *BS EN 20286-2:1993 ISO 286-2: 1988*. 1993.
13. Bridgeport, *XR-Series High-Performace 5-Axis Vertical Machining Centers*. 2008.
14. Jamshidi, J., A. Kayani, P. Iravani, P.G. Maropoulos, and M.D. Summers, *Manufacturing and assembly automation by integrated metrology systems for aircraft wing fabrication*. Proceedings of the Institution of Mechanical Engineers, Part B: Journal of Engineering Manufacture, 2010. **224**(1): p. 25-36.
15. Gray, I. and A. Kayani, *An Aerofoil Structure and a Method of Making a Rib for an Aerofoil Structure*. 2009, Airbus Uk Ltd.
16. Kayani, A. and I. Gray, *Shim for Arrangement Against a Structural Component and a Method of Making a Shim*. 2009, Airbus UK Ltd.
17. Lea, S.W. and G.E. Georgeson, *Fitting Doublers using Gap Mapping*. 2010, Boeing Co.
18. Etalon. *Applied Traceability*. 2008 [cited 2008 10th November]; Home Page]. Available from: <http://www.etalon-ag.com/>.
19. Dold, J., *Influence of large targets on the results of photogrammetric bundle adjustment*. International Archives of Photogrammetry and Remote Sensing, 1996. **31**(B5): p. 119-123.
20. Geodetic Systems, *Inca 3 - Picture Perfect Measurements*. 2005.
21. Dawson, J., G. Cork, G. Matthew, B. Bye, G. Hare, T. Gardner, G. McCormick, and G. Reitmayer. *Fuselage Trim and Drill Cell*. in *CMSC*. 2009. Louisville, Kentucky
22. Geodetic Systems, *Pro-Spot - True non-contact measurement*. 2005.
23. Leica. *Overview accessories for Laser Tracker Systems* 2008 [cited 2008 12th November 2008]; Available from: http://www.leica-geosystems.com/corporate/en/products/accessories/lgs_1598.htm.
24. Leica, *PCMM System Specifications: Leica Absolute Tracker and Leica T-Products*. 2008.
25. Crawford, T., *Aircraft Wing Box and Manufacture Thereof*. 2009: USA.
26. Hirano, Y., T. Mizutani, Y. Iwahori, and Y. Nagao. *An Investigation on Spring-In Behavior of Va-Rtm Composite Wing Structure*. in *16th International Conference on Composite Materials*. 2007. Kyoto, Japan