



Citation for published version:

Burke, RD, Brace, CJ, Cox, A, Lewis, A, Hawley, JG, Pegg, I & Stark, R 2011, 'Systems approach to the improvement of engine warm-up behaviour', *Proceedings of the Institution of Mechanical Engineers, Part D: Journal of Automobile Engineering*, vol. 225, no. 2, pp. 190-205. <https://doi.org/10.1243/09544070JAUTO1595>

DOI:

[10.1243/09544070JAUTO1595](https://doi.org/10.1243/09544070JAUTO1595)

Publication date:

2011

Document Version

Peer reviewed version

[Link to publication](#)

University of Bath

General rights

Copyright and moral rights for the publications made accessible in the public portal are retained by the authors and/or other copyright owners and it is a condition of accessing publications that users recognise and abide by the legal requirements associated with these rights.

Take down policy

If you believe that this document breaches copyright please contact us providing details, and we will remove access to the work immediately and investigate your claim.

Systems Approach to the Improvement of Engine Warm-Up Behaviour

RD Burke¹, CJ Brace¹, A Cox¹, A Lewis¹, JG Hawley¹, I Pegg² and R Stark²

1. University of Bath
2. Ford Motor Company

Abstract

Modifications to the coolant and oil circuits of a modern production 2.4L diesel engine have been made in an attempt to promote oil warm up to reduce fuel consumption. The new system used oil to cool EGR gases and incorporates a number of coolant flow control valves to reduce heat loss during warm up. The engine was run over cold start NEDC cycles with various flow strategies as a screening exercise to understand the behaviour of the system. Fuel consumption benefits of up to 4% were observed, but these were accompanied with 3% increases in NO_x emissions. Detailed analysis of the coolant flows and temperatures showed that when throttling the flow, the mass of coolant in the degas bottle and radiator could be isolated from the system during warm up, essentially reducing the thermal inertia. Heat transfer directly to the oil from EGR gases rather than via the coolant allowed more heat to be put into the oil, with engine oil supply temperatures up to 6°C hotter, however it was not possible to verify that the oil was hotter at the bearings, valve train and cylinder liner. The engine strategy was seen to react to the faster warm up and retard injection timing, reducing NO_x but also compromising overall fuel consumption benefits. Further tests were conducted with varying injection timing to establish a NO_x/fuel consumption trade off to demonstrate further benefits when the engine strategy is included in the operation of novel thermal management systems.

1 Introduction

With the increased environmental, economic and legislative drivers requiring better fuel economy, interest in all engine subsystems are being investigated for improved performance. Engine thermal management systems (TMS) offer a relatively large potential for innovation with most systems using similar components over the past 20 years. Whilst research is ongoing in the area too often studies remain isolated in improving the efficiency of the sub system alone. However, to achieve the full benefits of this system, a global systems approach needs to be taken, looking at the interactions of the engine TMS with other subsystems [1].

Previous studies on engine TMS have targeted improving the efficiency of the system by decoupling the coolant flow rate from engine speed. This is usually achieved by replacing the mechanical pump and thermostat by an electric pump and control valve [2-4], but is often a costly alternative. In addition to matching the pumping power to the cooling requirements, these systems have subsequently allowed independent control over the cooling system other than simply controlling a top hose coolant temperature as with the traditional thermostat. Engine cooling can then be controlled using a target metal temperature rather than a target coolant temperature. This matches engine cooling to the thermal loading and avoids the constraints of a system designed to function under extreme conditions by allowing hotter coolant, and hence hotter oil, at lower loads to reduce frictional losses [5-7].

Current developments tend to concentrate on engine warm up cases and have given mixed results. Brace et al [8] throttled main coolant flows during a cold start drive cycle but whilst fully warmed up temperatures were influenced by this setup, engine warm up showed no improvement. In contrast, Choukroun and Chanfreau [9] did achieve faster warm up when completely stopping coolant flow. In both these cases the modifications to the production engine were relatively

inexpensive and offer a pragmatic approach to engine cooling control. Heat energy recovery has offered another potential for improved cold start, with the potential demonstrated by comparing cold start tests to a hot start test [10]. Andrews et al [11] achieved faster warm up by using a coolant to exhaust gas heat exchanger before the coolant to oil heat exchanger which yielded up to 8-10% fuel consumption benefits depending on the duration of the test. Hawley *et al.* [12] have investigated the effects of using heaters in the transmission oil for improved fuel consumption and demonstrated a 0.7 per cent improvement in fuel consumption using a 1080W heater, however the heaters were externally powered and the result did not take into account any adverse effects on fuel consumption from higher electrical demands. The authors concluded that such a system would only likely to be implemented by using waste heat from the exhaust flow, but that the costs in implementing such a system without affecting after-treatment devices would be significant.

When considering previous studies from the literature, the methods for improving fuel consumption using the engine TMS have been to allow the engine oil to heat up faster to reduce frictional losses. This work bases itself on results from a production engine with concept cooling and lubrication circuits. After assessing the benefits of the new system from a fuel consumption perspective, a detailed analysis of the interactions with the engine control systems will be presented.

2 Methodology and experimental setup

The baseline engine was a production 2.4L, 4 cylinder common rail direct injection Diesel engine loaded using a transient AC dynamometer under the control of the CP Engineering Cadet 12 software. The engine was run over the New European Drive Cycle (NEDC), simulating the loading of a small commercial vehicle. The engine hardware was EURO IV emissions standards specification for light duty commercial vehicles, however due to the specific constraints of the experimental installation, the EGR calibration used here was not representative of a production

engine and the NO_x emissions exceeded this limit in this particular case (details of this calibration issue are provided in section 3.5, engine strategy analysis). All tests were conducted from a 25°C cold start condition following an overnight temperature soak period.

Engine fuel consumption was estimated using a gravimetric fuel balance whilst exhaust gas concentrations of oxides of nitrogen (NO_x), carbon monoxide (CO), carbon dioxide (CO₂) and unburned hydrocarbon (THC) were estimated according to British standards [13].

In addition to common engine instrumentation, 4 non-intrusive ultrasonic flow meters were installed in various legs of the coolant circuit to monitor all flows in the system. Coolant volume increases were kept to a minimum, avoiding large increases in thermal inertia. The majority of engine auxiliaries were fitted to the engine, though the cabin heater, usually an integral part of the TMS, had been removed. A number of major modifications to the cooling and lubrications circuits were made which are listed below; these modifications introduced a number of additional calibration variables which were then adjusted to assess potential benefits in fuel consumption. This publication reports on the initial findings from this work.

2.1 Lubrication circuit setup

The engine lubricant circuit had undergone the largest changes from the production engine with the inclusion of an external circuit designed to supply heat to the oil. A second EGR cooler, where gases were cooled by the oil, was run in parallel to the conventional coolant cooled EGR. Although physically laid out in parallel, for ease of controlling EGR rates only one of the two coolers was used at any one time. The flow of EGR gases was controlled using production EGR valves with one mapped to the engines conventional strategy and the other closed. The production engine incorporated a coolant to oil heat exchanger and the oil cooled EGR cooler was incorporated in series with this before being filtered and supplied to the oil gallery. A diagram of the modified oil

circuit is shown in figure 1. In its prototype form, the system would have significant impacts on production costs; however it is difficult to quantify the impact of a production system based on this proof-of-concept setup. However, as EGR is a well established system in Diesel engines, the cost are likely to be more realistic to a production setup than the exhaust waste heat recovery considered by Hawley et al. [12].

The conventional oil pump was replaced with a variable flow oil pump (VFOP) which was controlled to provide a target oil gallery pressure. To ensure sufficient oil supply to the engine with the external circuit, an additional 0.6L of oil was used compared to the standard engine fill (6.5L).

2.2 Coolant circuit setup

The engine coolant circuit was modified from the baseline at a number of points. The conventional thermostat had been replaced with a more advanced Pressure Regulated Thermostat (PRT). This component is still based on a wax element, however it is sensitive to both top hose and bottom hose coolant temperatures meaning that when a large cooling potential is available over the vehicle radiator the thermostat will have a tendency to stay closed even if top hose temperatures are hot [8].

A diagram of the coolant circuit is shown in figure 2. To allow additional control over coolant flows, three throttle valves were installed in addition to the PRT:

- (a) Engine out coolant throttle
- (b) EGR cooler loop coolant throttle
- (c) Oil cooler control valve

The valves have proven to be an inexpensive method for controlling coolant flows compared to the full electrical systems and are therefore more likely to be considered in a production setup.

The modifications to the oil and coolant circuits allowed control of the following parameters:

- Control of engine out coolant flow
- Control of coolant flow in EGR cooler circuit
- Control of coolant flow to oil cooler
- Control of oil pressure using VFOP
- Use of coolant or oil cooled EGR
- Change of other common calibration parameters, notably injection timing

However, the additional freedom also means that these parameters would require optimisation to enable maximum benefits from the modified system and a series of screening tests were performed to investigate the effects of each of these. As with the oil circuit, the total coolant volume was increased in the prototype setup by approximately 2L over the standard 8L, however the majority of this increase is a result of the flowmeters rather than the additional hardware.

2.3 Experimental operating points

For each test setup detailed below, all of the hardware was fitted to the engine. As a result, the baseline setup considered here would probably yield worse cold start fuel consumption than the production baseline, but this would provide an appropriate comparison for subsequent setups. Whilst every effort has been made to reduce coolant and oil volumes, ultimately these were done within the constraints of the prototype setup. Of the many variations in control parameters that were tested, four setups will be presented in detail in this publication (see Table 1). Details of each experimental setup considered are listed in appendix 8.3 and the results will be used to later in this work for establishing correlations.

	Engine out coolant throttle	EGR cooler coolant flow	Oil cooler coolant flow	EGR cooler	VFOP
Uncontrolled	Non Controlled	Non Controlled	Open	Coolant	Max Flow
Baseline	Non Controlled	Non Controlled	Open	Coolant	Controlled*
Build 2	Mapped [#]	Non Controlled	Open	Oil	Controlled*
Build 3	Mapped ^{&}	Restricted	Open	Oil	Controlled*

* Controlled oil flow is based on a target oil gallery pressure of 2bar

Build 2 mapped coolant flow inhibits coolant flow until a head metal temperature of 95°C is reached and subsequently opens as a function of head temperature and engine speed.

& Build 3 mapped coolant flow is similar to build 2, only throttle opening occurs at 105°C engine head temperature

Table 1: Experimental setups for detailed analysis

Engine out coolant throttle control was mapped according to required engine cooling power based on engine head metal temperature which is the base engine temperature measure for all ECU calibrations. Until a threshold temperature, the valve remained shut, keeping flow in the main coolant circuit to a minimum.

EGR cooler coolant throttle was set to a constant opening based on a flow of coolant at idle. Whilst this is a very crude way of controlling flow it does allow easy and effective reduction of flow for this preliminary experimental investigation.

Coolant was always flowed to the oil cooler. A limited number of tests were conducted with the oil cooler bypassed, but yielded worse overall results. When analysing the coolant temperatures these were found to lead oil temperatures in all cases meaning that flowing coolant to the oil cooler would always be beneficial, as well as contributing to the heating of the oil cooler structure.

3 Results

3.1 Fuel consumption analysis

Fuel consumption for each of the four setups is shown in figure 3 along with expected 95% error bars based on previous knowledge of the engine/dynamometer facility. The first point to note is that changes in fuel consumption are small and of the order of 1%. The largest benefit was achieved by using the VFOP which yielded a 22g (2%) improvement. Heating the oil using EGR gases and throttling coolant flow during warm up yielded a further 20g (2%) improvement when considering the gravimetric measure. However, throttling the coolant flow further led to a slight increase in fuel consumption (approx 5g).

Fuel consumption changes were as expected between the uncontrolled and baseline setups with the reduction of oil pumping power resulting in lower fuel consumption. Again, when progressing to build 2, the restriction of coolant flow and direct addition of heat to the engine oil would provide faster warm up and reduced frictional losses contributing to lower fuel consumption. Restricting flow further in the case of build 3 was expected to improve warm up further and yield further fuel consumption benefits however this was not the case.

Figure 4 shows the bulk oil temperatures over the drive cycle for each of the engine setups. Apart from the uncontrolled setup, oil temperatures correlate well with fuel consumption values indicating the strong link with engine frictional losses and a dominance of hydrodynamic lubrication within the engine [1]. The uncontrolled case is slightly unusual as the bulk oil temperature is similar to that of build 3, however it is important to identify where the additional heat is generated. In the case of build 3, this was achieved by using the oil EGR cooler however in the uncontrolled case this is a result of higher oil pumping work due to the uncontrolled oil pressure. The higher oil temperature

would be expected to reduce frictional losses and improve fuel consumption; however this is offset by the higher pumping work which ultimately leads to higher net fuel consumption.

Whilst fuel consumption is affected by engine friction and bulk lubricant temperatures, it is important to note that other factors have significant effects. An analysis of the coolant flow strategies will be presented as a way of demonstrating the control settings. The external oil circuit will then be considered showing the potential benefits from the novel design and finally engine NOx emissions will be analysed leading into engine control strategy.

3.2 Coolant circuit analysis

3.2.1 Flow analysis

Coolant flows in the uncontrolled and baseline setups are similar as no control of the coolant throttles was implemented and as a result the results from the uncontrolled setup will be ignored at this stage. Comparisons of the coolant flow in each of the three remaining setups are shown in figure 5. For this analysis, the engine coolant circuit is split up into two loops:

- **The cooling loop** which is the main external loop from the engine in which the PRT defines the proportion of coolant flowing to the radiator. This loop also includes the Degas bottle.
- **The heating loop**, where coolant can be used to cool EGR gases, effectively heating the coolant, and to heat or cool oil in the oil cooler.

The main engine out coolant throttle was not controlled in the baseline setup and, as can be seen in figure 5, the coolant flow rate at the “Engine Out” station varied between 10 and 100l/min. In builds 2 and 3 the throttle is controlled depending on engine head temperature. When the engine is cold, the coolant throttle remains closed, reducing coolant flow in the cooling loop. Although the results from the flowmeters suggest flow is completely inhibited in this loop, analysis of coolant

temperatures in figure 6 show that there is some leakage as pump return temperatures increase throughout the test. This is not reflected in the engine out and top hose coolant flows because of the measuring range of these flow meters. The flow meters are based on electromagnetic flow measurement principle [14], based on a flow velocity measurement. Measurement accuracy is very good over most of the measuring range, however it increases exponentially for velocities below 1m/s, And excessive for velocities below 0.1m/s. For the engine out and top hose flow meters this represents approximately 3L/min whereas for the degas flow this limit is 0.5L/min. It is only late on in the drive cycle, during the high power extra urban drive cycle (EUDC) that the throttle opens and allows significant flows of up to 25l/min to circulate. In cooling loop, the majority of the flow passes down the bypass loop as the engine is cold and the PRT will remain closed for the majority of the drive cycle. However, in the baseline setup a flow of up to 2l/min flows to the inlet of the radiator suggesting some leakage in the thermostat. However, when looking at the flow from the degas bottle, it would appear that this flow is mostly going to the degas tank. There is a small flow from the degas bottle in builds 2 and 3, but the top hose temperatures suggest this is not significant (figure 6).

The coolant throttle in the heating loop remains open in the baseline and build 2 setups, but partially closed in build 3. In the first two cases coolant flows of the order of 10l/min are seen throughout the drive cycle, however the effect of closing the throttle reduces flow significantly to less than 3l/min over the test. This demonstrated good control of coolant flows using the current hardware. It is interesting to note that coolant flows in build 2 are larger than in the baseline condition. This will be due to the closing of the main engine out throttle meaning the coolant pressures will be higher, allowing more through the narrow passages of the heating loop. Coolant pressures were, however, not monitored in this study and so it is not possible to verify this at this stage.

3.2.2 Temperature and energy analysis

Coolant temperatures were monitored and are compared for the three setups in figure 6. Using the combined temperature and flow data it was possible to establish the energy exchanges through the various components of the circuit as described in equations 1 and 2.

$$\dot{Q} = \dot{m} \cdot c_p \cdot \Delta T \cdot dt \quad (1)$$

$$Q = \int \dot{Q} dt \quad (2)$$

Cumulative heat exchanges over the 4 urban cycles (first 780 seconds) are reported in figure 6 for:

- (a) Heat loss from combustion chamber
- (b) Heat lost to ambient air flow in the radiator
- (c) Heat flow to oil in the oil cooler
- (d) Heat picked up from cooling of EGR gasses in the EGR cooler

This period corresponds to the warm-up period and has been considered representative for energy exchange analysis. The EUDC includes large energy flows that may mask warm up effects such as after the PRT opening and when heat flow reverses to cool oil in the oil cooler. In all cases, a negative energy value signifies that heat flow was opposed to the direction of the corresponding arrow.

The temperature distribution in figure 6 shows that despite the flowmeters reading no flow in the engine out, there is clearly a degree of leakage causing a temperature rise in the pump return leg. However, the top hose temperature shows that in builds 2 and 3 the flow through the radiator and degas bottle is negligible. In the baseline test, the temperature rises with engine out temperature, however in the other two tests the temperature remains at around 25°C until the PRT opens. It is not obvious why the degas flow is inhibited following main engine out coolant throttle closing,

however one cause may be reduced coolant pressure due to the flow throttling. The effect of this will be to isolate the coolant in the degas bottle during warm-up, thus reducing overall thermal inertia.

When considering the heat energy exchanges in figure 6, it can be seen that the heat loss from combustion reduces when the coolant flow is throttled. Coolant flow through the engine is high in baseline and build 2 but significantly throttled in build 3: As a result, the heat loss is over 600kJ less. Heat transfer in the engine will be reduced by lower coolant velocities but the faster warm-up rate is explained by lower thermal inertia. Figure 7 shows the main energy flows from the combustion chambers and shows that lower heat loss is not compensated by lower fuel usage or higher exhaust gas enthalpy, and would therefore be expected to remain within the engine structure.

Using the oil to cool EGR gases removes the heat addition to the coolant over the EGR cooler and heat is effectively lost over this component. The knock on effect is that heat transferred to the oil in the oil cooler is reduced due to lower heating capacity of the coolant. The significantly lower flow rate in build 3 will further reduce the heating capacity in the oil cooler which is reflected in the lower energy exchange (see figure 6). The effectiveness of oil to cool EGR gases has not been quantified in this study, however the effect on NO_x emission appears small showing that sufficient cooling is available during the warm up phase.

3.3 Lubricant circuit analysis

Analysis of the modified oil circuit is limited compared to that of the coolant circuit as flow rates in the system are not known. However, the analysis will be conducted by looking at the pressure drop and temperature rise over the external circuit (between stations 1 and 2 in figure 1). Figure 8 shows the pressure drop in the external oil circuit for the modified oil circuit over the NEDC drive cycle. Also shown for reference, is an example of the pressure drop for the same engine, without the

external oil circuit. It is clear that the pressure drop is about 0.5bar higher with the additional EGR cooler over the 4 urban drive cycles and almost 2bar during the 120kph cruise. In the prototype setup this rise in flow resistance is unavoidable and will increase fuel consumption due to higher pumping work; however optimisation of the layout in a production engine would be expected to reduce this effect significantly.

Figure 9 shows the oil temperature rise over the external circuit for the baseline condition and builds 2 and 3. For reference, the temperature rise for the production system is also shown. The production system is the engine running without any of the additional hardware which avoids any heat losses to ambient that may occur in the external circuit.

There is a clear difference between the baseline and the two subsequent builds which use the oil cooled EGR system with the oil hottest in the case of build 2 (non throttled coolant flow in the heating loop). In the baseline case, when heat flows from EGR gases to the coolant, and then from coolant to oil, the temperature rise of oil over the external circuit is about 2°C over the 2nd, 3rd and 4th urban cycles. Over the 1st urban drive cycle the oil temperature decreases by up to 2°C, probably as a result of heating the oil cooler and filter components. In contrast, when the oil EGR cooler is used and heat flows directly from the EGR gases to the oil, an increase in oil temperature of up to 8°C is achieved for all of the urban cycles. This shows that the oil temperature can be increased with the modified setup and would be expected to yield better fuel consumption. Oil temperature rise is lower in build 3 than in build 2 (i.e. when coolant flow is throttled in heating loop).

In all cases towards the end of the drive cycle the temperature gradient reverses and the oil is cooled in the external circuit. This is a result of oil temperatures overtaking coolant temperatures as the

coolant thermostat opens allowing flow through the radiator. If further oil heating is required then it is important to further control coolant flows at this point to avoid adverse oil cooling.

3.4 NO_x analysis

Whilst running an engine hotter can reduce fuel consumption through lower friction, it must not impact heavily on emissions which remain a key factor in engine development. Increasing engine temperatures can be beneficial to some emissions such as CO, THC (see table 2) and smoke which are the result of incomplete combustion; however oxides of nitrogen (NO_x) emissions increase at higher temperatures. Figure 10 shows the total NO_x emissions over an NEDC cycle for the four engine builds and again 95% error bars are based on previous facility knowledge.

Test	Hydrocarbons	CO
Baseline	4.7g	23g
Build 2	6.8%	7.6%
Build 3	6.2%	7.4%

Table 2: Hydrocarbons and CO emissions from baseline test and percentage improvement in subsequent builds

The engine hardware and control strategy were specified to EURO IV emissions regulations, however these results exceed those specified limits. As will be discussed in section 3.5, this was due to the lack of road data feedback on the dynamometer setup causing some ECU hardware protection strategies to be implemented, reducing the EGR rate to below the production engine levels. When considering the physical mechanisms, it is not surprising that a rise in NO_x emissions occurs between the baseline setup and build 2. Hotter engine temperatures would increase the reactions described by the Zeldovich model [15] causing the rise of around 0.2g (≈3%). The result from build 3 is more unexpected as the engine runs hotter (see coolant temperatures, figure 6) and a further increase in NO_x emissions would be expected. Whilst further investigation into this aspect is

necessary, the result does follow a similar trend to the fuel consumption results shown in figure 3. The higher NO_x in the uncontrolled condition will probably be the result of the higher fuel consumption which increases in-cylinder temperatures.

To better understand the NO_x results it is necessary to look at the detailed NO_x formation throughout the NEDC cycle. Figure 11 shows the cumulative NO_x and the difference in cumulative NO_x relative to the baseline setup. Firstly it is obvious that the final NO_x result is heavily dependant on the final two points on the drive cycle: approximately 75% of NO_x are formed during the 100kph and 120kph cruises and the associated transients. The particularity of these last high power points of the cycle is also apparent when considering the difference graphs: for builds 2 and 3, less NO_x are produced over the first part of the drive cycle, however over the last two stages significantly more NO_x is produced giving a net increase in the case of build 2 and similar overall NO_x in build 3.

An insight into the causes of lower NO_x as a result of faster warm up is given by looking at the engine control variables. As explained previously, a hotter engine would be expected to cause an increase in NO_x, however this is only the case for the very final part of the NEDC drive cycle.

3.5 Engine strategy

The two main engine calibration parameters that affect NO_x emissions and fuel consumption are injection timing and EGR rates. Each of these will be considered along with engine head metal temperature which is a key input to the engine control system. This section will assess the impact of coolant throttling on the ECU behaviour.

The engine control of injection timing and EGR rates is dependant on a large number of factors, but amongst the most significant are accelerator pedal position, relating the torque demand from the driver and the engine head temperature. Figure 12 shows the engine cylinder head temperature over

the NEDC for the baseline and build 2 setups. To improve clarity, temperatures during transient events have been removed. As expected, the temperature in build 2 is higher than in the baseline which corresponds to the same increases seen in the oil and coolant analysis.

Figure 13 shows the injection timing for baseline and build 2 setups. Also included is the cumulative injection timing which has little physical meaning, but is more appropriate for showing differences between the two tests due to the transient nature of engine behaviour. Injection timing is expressed as degrees before top dead centre ($^{\circ}$ BTDC), meaning a lower negative value indicates a more retarded condition. It can be seen that injection timing is more advanced at the beginning of the drive cycle; this allows for longer ignition delay and less favourable combustion conditions when the engine is cold. As the engine warms up, injection is gradually retarded to control engine NO_x emissions.

Figure 14 (a) shows the EGR rate for the baseline setup and the difference plots for builds 2 and 3 and the baseline EGR. The EGR measurements are based on the ratio of CO_2 in the inlet to the exhaust manifolds and estimated based on two independent CO_2 measurements. Although care has been taken to correctly time align these measurements, small differences during transient events mean a reliable measure is not possible at this stage, and a moving average filter has been applied. Initial observations show the EGR rate appears 4% and 7% higher for the majority of the urban cycles in builds 2 and 3 respectively. However, closer observation in figure 14 (b) shows that this is only the case during idle phases and EGR tends to be much closer to the baseline during accelerations and cruises. During the EUDC phase, EGR rates become almost equal in all tests with small differences occurring over the transient events. It is not obvious as to the cause of these effects as a faster warm up would be expected to cause a drop in EGR as the engine control system

attempts to maintain a desired intake mass airflow. This would suggest that the effects here on EGR are minimal.

Over the first 800s of the drive cycle, the net effect on NO_x emissions in builds 2 and 3 will be the combination of a hotter engine, retarded injection and EGR changes. The warmer engine would be expected to increase NO_x emissions whilst the retarded injection timing would decrease emissions [16]. The effects of EGR may only be significant when the engine is under load (not idling or decelerating), at which points EGR rates are similar in the baseline and modified setups (figure 14 (b)). Referring back to the NO_x results in figure 11, the effect of injection timing would appear larger as there is an overall reduction in NO_x. This suggests an over-compensation by the engine ECU due to the increase in temperature which will be compromising the potential benefits in fuel consumption. This is caused by the engine temperature being estimated based on a single temperature measurement in the cylinder head that is not representative during engine warm up.

When engine cylinder head temperature is above 80°C (after 600s), the injection timing is similar in both tests (the cumulative graphs stop diverging). This shows that above a certain engine temperature, injection timing becomes essentially independent of temperature. Unlike injection timing, EGR rates were similar over the majority of the drive cycle (figure 14), however small differences during the last parts of the EUDC will have a large effect on overall NO_x due to the importance of NO_x contribution of this phase.

It is important to note the very low EGR rates over final acceleration and the 120kph cruise (figure 14(c)). This would not be standard operation on the production engine, but is a consequence of ECU hardware protection strategies activating due to a lack of road data feedback on the dynamometer setup. The degraded EGR calibration in this prototype setup, combined with the high rate of NO_x

production over this part of the drive cycle explains why the EURO IV emissions limits were not respected for NO_x emissions. An increase in EGR rate would increase overall fuel consumption and reduce overall NO_x, creating a shift of the NO_x fuel consumption trade off.

4 Discussion

The points noted above have been observed by considering only 4 different setups, however results from a larger series of setups will now be considered (detailed in appendix 8.3). It was seen that during the urban phase of the NEDC, lower NO_x occurred when the engine was hotter because of retarded injection. For each test, total NO_x emissions over the urban stage of the drive cycle have been plotted against cumulative engine temperature and cumulative injection timing (figure 15). Whilst these cumulative values have little physical meaning, they do give an estimate of temperature and timing over the period as a whole. In the case of cumulative temperature, a higher value signified that the engine has operated hotter on average. In the case of cumulative injection timing, a higher number indicates that the engine has run with more advanced timing.

As was expected from the previous results, hotter engine yields lower NO_x over the urban phase of the drive cycle due to retarded injection. Figure 16 shows the close correlation of engine temperature and injection timing over this first stage of the drive cycle and confirms the strong dependence on engine temperature within the engine ECU strategy. It would be expected that a hotter engine would cause an increase in NO_x emissions, but the retarded timing offsets this and causes the net decrease [16].

In contrast to results over the first stage, over the last 150 seconds (100kph and 120kph cruises), no strong correlations were seen based on engine temperature, injection timing or EGR alone (R^2 values less than 0.3). To understand these effects a linear response model was generated based on

these three inputs and a snapshot is shown in figure 17 for injection timing and temperature at the mean EGR condition. Although neither injection timing nor EGR were directly perturbed, the effect of engine temperature on engine strategy caused variations. A response model was necessary due to the cluster of tests for which injection is slightly retarded (cumulative injection timing - 170°BTDC.s) which shows that injection timing has an impact on NO_x emissions in this region. The model also showed that engine temperature has a strong effect on NO_x emissions under these conditions. The effect of EGR has not been shown as this effect was small compared to other factors. This was thought to be due to small excitations rather than small effects as over the 150 seconds, EGR rate varied by less than 1% and, as shown in figure 14 (c) was not used over the final 50 seconds.

Maintaining the main engine out coolant throttle closed over the warm up period effectively removed the volume of coolant in the radiator and degas bottle from participating in the warm up, effectively reducing the thermal inertia. In addition, the reduced heat transfer to the coolant suggests more heat remains in the structure, however due to the lack of instrumentation on the current engine this could not be verified experimentally and will be the topic of ongoing research. It is important to note that it is the combination of the reduced thermal inertia of the coolant and the reduced heat transfer that allow the engine to warm up faster. Lower heat transfer to a similar mass of coolant would simply allow the structure to run at a higher temperature compared to the coolant, but the coolant warm up rate would be slowed down. Reducing the coolant inertia allows it to warm up faster, whilst also allowing the structure to run with a higher temperature differential. Isolating parts of the coolant circuit (radiator and degas bottle) does mean care needs to be taken when this cold volume is bled back into the system to avoid oscillatory behaviour and a rapid drop in all temperatures.

The design was capable of adding heat to the oil as higher temperature differences were observed over the external circuit. However, it is unclear whether this increased temperature translates in to hotter oil at key locations in the engine. To reduce viscous losses, it is necessary to have hotter oil in all bearings (main, connecting rod, camshaft...), valve assembly and piston rings. It will be important to investigate how well the oil retains the additional heat supplied to it or whether this is lost very quickly to the cold structure. The concept considered in this design does not increase the amount of heat going to the system as a whole, but attempted to redistribute the energy flow to promote flow to the oil by bypassing the coolant. In the production setup, heat flows from the EGR gasses to the coolant, and subsequently to the oil in the oil cooler, however in the modified setup heat can flow directly to the oil. Further research and measures are necessary to assess the linkage of oil and structure temperature as the additional heat put into the oil may simply end up in the structure rather than reducing engine friction

The setups with faster warm up resulted in benefits in both fuel consumption and NO_x as a result of higher engine head temperatures and retarded injection. This reduction in NO_x can be viewed as compromising the overall potential for reduced fuel consumption and as a result advancing the timing under these conditions could increase the fuel consumption benefits. The following section aims to investigate this potential.

5 Further Testing

To assess the potential improvement in fuel consumption under iso-NO_x conditions, a series of tests were produced in the Build 3 condition, but with varying injection timing over the 4 urban cycles. Three separate tests were conducted where injection timing was advanced by 5°, 3° and 1° BTDC, but timing was restored to the default value for the EUDC to limit the impact on NO_x emissions. The effects of faster warm up over the final stage of the EUDC was seen to dramatically increase

NO_x emissions meaning that to maintain iso-NO_x a retarded injection strategy would need to be employed. This would deteriorate fuel consumption and as a result it was deemed that operating at the higher temperatures in this region would need to be reviewed. The experimental conditions used here increased both warm up rate and final coolant operating temperature by throttling flow and increasing valve opening thresholds. By reducing the main valve threshold the hot operating temperature would not be changed significantly to the production vehicle, without reducing the faster warm up rate. The following analysis will therefore concentrate on the 4 ECE cycle, corresponding roughly to the warm up period of the engine. It is also arguable that this would be more representative real life driving conditions [17] as this would represent a journey from cold start of around 4km and 13 minutes.

Figure 18 shows the injection timing for the baseline test, and the offset of injection timing of the three advanced tests. The figure shows that a constant offset is maintained despite the transient nature of the drive. EGR rates have also been compared for each of the drive cycles and similar offsets to those shown in figure 14 were observed between the baseline and each of the advanced timing tests run under build 3 conditions. Differences in EGR rates between the build 3 tests run at different timings were insignificant.

The impact of offset injection timing on NO_x emissions is shown in figure 19. These are compared to the baseline condition: as was observed previously in figure 11, the effect of faster warm up results in lower NO_x as a result of retarded injection. Advancing the timing at these conditions raises the NO_x emissions closer to the baseline at 1° advanced, and ultimately increases NO_x for 3° and 5° advance.

The results over the 4 urban cycles are presented in the form of a NO_x/Fuel consumption trade off in figure 20. This allows an estimate of the potential fuel consumption benefit at iso-NO_x to be made and highlights the need to include the engine strategy in any modifications to the engine cooling circuit.

The shape of the trade off curve is somewhat unexpected as it is concave with respect to the origin of the trade off graph. It would be expected that the shape be convex, as often seen with EGR or injection timing swings. However, the curve shown in figure 19 represents only a small section of the overall trade off curve that would be achieved if timing were varied over a wider range. In this small section of the curve it is reasonable to assume that a linear fit to the data would be a good approximation of the relationship. In fact, when fitting a curve to the data, only a linear fit has any validity, with any higher order fits subject to overfitting, suggesting that the concave shape of the curve is a function of experimental scatter in the data.

6 Conclusions

A novel design of engine cooling and oil circuits has been implemented on a production diesel engine. Small benefits in fuel consumption and NO_x emissions were achieved of about 40g (4%) but the magnitude of these results highlight the need for repeat testing and good control of experimental conditions to increase confidence in the results. However, when the engine is operating hot and at higher loads, it is important to maintain NO_x emissions under control which limits the possibility of operating at higher temperatures. EGR was not used to its full potential in this study, but it will be interesting in subsequent experimental work to incorporate this and analyse any interactions with the thermal management system on a NO_x control basis.

The changes to the cooling circuit and flow strategy were seen to impact the engine control strategy through modified warm up profiles. The work has also highlighted that during warm up higher engine head temperature will not necessarily increase NOx and it is important to take into account the temperature distribution rather than a single point measurement. This highlighted the need for a global systems approach to be adopted to take full advantage of the benefits from the modified setup. In addition, increased instrumentation is required to better understand energy flows within the engine fluids and structure

Acknowledgements

The authors would like to acknowledge the funding support for this project received from the Technology Strategy Board. Also, the funding from the collaborating partner, the Ford Motor Company and the support and input from their technical staff are acknowledged, as well as their permission to publish this paper. The work has been conducted in the Powertrain and Vehicle Research Centre in the Department of Mechanical Engineering at the University of Bath with the assistance of the support and research staff.

7 References

- 1 **Burke, R.D., Brace, C.J. and Hawley, J.G.** Systems analysis of the interactions of thermal, lubricant and combustion processes of Diesel engines. *Proceedings of the Institution of Mechanical Engineers Part D-Journal of Automobile Engineering*, 2010, **224**(5) pp.681-704
- 2 **Brace, C.J., Burnham-Slipper, H., Wijetunge, R.S., Vaughan, N.D., Wright, K. and Blight, D.** Integrated Cooling systems for Passenger vehicles, SAE Paper Number 2001-01-1248, 2001.

- 3 **Wagner, J.R., Ghone, M.C., Dawson, W. and Marotta, E.E.** Coolant flow control strategies for automotive thermal management systems, SAE Paper Number 2002-01-0713, 2002.
- 4 **Chalgren, R.D.J.** Thermal comfort and Engine warm up Optimization of a low flow advanced Thermal management system, SAE Paper Number 2001-01-0047, 2004.
- 5 **Ap, N. and Tarquis, M.** Innovative Engine cooling systems comparison, SAE Paper Number 2005-01-1378, 2005.
- 6 **Matteo, L.D.I., Fortunato, F., Oliva, P., Ercole, M., Mariniello, F., Montieri, A., Scala, S., Loddo, A. and Martinetto, M.** New and advanced cooling system concept for small cars, *Vehicle Thermal Management Systems (VTMS) 6*, pp. 685-694 (Professional Engineering Publishing, Brighton, United kingdom, 2003).
- 7 **Couetouse, H. and Gentile, D.** Cooling System control in Automotive Engines, SAE Paper Number 920788, 1992.
- 8 **Brace, C.J., Hawley, G., Akehurst, S., Piddock, M. and Pegg, I.** Cooling system improvements - Assessing the effects on emissions and fuel economy. *Proceedings of the Institution of Mechanical Engineers, Part D: Journal of Automobile Engineering*, 2008, **222**(4), 579-591.
- 9 **Choukroun, A. and Chanfreau, M.** Automatic Control of Electronic Actuators for an Optimized Engine Cooling Thermal Management, SAE Paper Number 2001-01-1758, 2001.
- 10 **Kunze, K., Wolff, S., Lade, I. and Tonhauser, J.** A systematic analysis of CO2 reduction by an optimized heat supply during vehicle warm up, SAE Paper Number 2006-01-1450, 2006.
- 11 **Andrews, G.E., Ounzain, A.M., M. Li H., B., Tate, J. and Ropkins, K.** The use of a water/Lube oil heat exchanger and enhanced cooling water heating to increase water and lube oil heating rates in passenger cars for reduced fuel consumption and CO2 emissions during cold start, SAE Paper Number 2007-01-2067, 2007.

- 12 Hawley, J.G., C.D., B., Brace, C.J., Akehurst, S., Pegg, I. and Avery, M.R.** The Effect of Engine and Transmission Oil Viscometrics on the vehicle Fuel Consumption. *Proceedings of the Institution of Mechanical Engineers, Part D: Journal of Automobile Engineering*, 2010, **In Press**.
- 13 BSI.** BS ISO 8178-1:2006, Reciprocating internal combustion engines. Exhaust emission measurement. Test-bed measurement of gaseous and particulate exhaust emissions. (BSI, 2009).
- 14 Hofmann, F.** Fundamental Principles of Electromagnetic Flow Measurement, 3rd Edition, Krohne, available from: http://www.krohne.com/fileadmin/media-lounge/PDF-Download/Magmeters/HB_MID_e.pdf [accessed 21st June 2010]
- 15 Musculus, M.P.B.** On the correlation between NO_x Emissions and the premix burn, SAE Paper Number 2004-01-1401, 2004.
- 16 Burke, R.D. and Brace, C.J.** The Effects of Engine Thermal Conditions on Performance, Emissions and Fuel Consumption, SAE Paper Number 2010-01-0802. *SAE World Congress 2010* (SAE International, Detroit, USA, 2010).
- 17 Andre, M.** Experimental study on the actual uses of the cars (E.U.R.E.V.), SAE Paper Number 890874, 1989.

8 Appendix

8.1 Abbreviations

BTDC:	Before Top Dead Centre
CO:	Carbon Monoxide
CO ₂ :	Carbon Dioxide
ECU:	Engine Control Unit
EGR:	Exhaust Gas Recirculation
EUDC:	Extra Urban Drive Cycle
NEDC:	New European Drive Cycle

NO _x :	Oxides of Nitrogen
PRT:	Pressure Regulated Thermostat
THC:	Total Unburned Hydrocarbons
TMS:	Thermal Management System
VFOP:	Variable Flow Oil Pump

8.2 Notation

Adj R ² :	Adjusted Coefficient of Determination
C_p :	Coolant Specific Heat Capacity
\dot{m} :	Coolant Mass Flow Rate
PRESS R ² :	Predicted Residual Sum of squares R ²
Q :	Heat
\dot{Q} :	Rate of heat transfer
R ² :	Coefficient of Determination
T :	Temperature
t :	time

8.3 Detailed list of all experimental setups

Designation	Engine out coolant throttle (opening temperature [#])	EGR cooler coolant flow (%max flow at idle ^{&})	Oil cooler coolant flow	EGR cooler	VFOP
Uncontrolled	Non Controlled	Non Controlled	Open	Coolant	Max Flow
Baseline	Non Controlled	Non Controlled	Open	Coolant	Controlled [*]
Build 2	Mapped (95°C)	Non Controlled	Open	Oil	Controlled [*]
Build 3	Mapped (105°C)	Restricted (8%)	Open	Oil	Controlled [*]
N/A	Mapped (90°C)	Max	Open	Coolant	Controlled [*]
N/A	Mapped (90°C)	Restricted (50%)	Open	Coolant	Controlled [*]
N/A	Mapped (90°C)	Max	Bypassed	Oil	Controlled [*]
N/A	Mapped (90°C)	Restricted (17%)	Open	Oil	Controlled [*]
N/A	Mapped (90°C)	Restricted (17%)	Bypassed	Oil	Controlled [*]
N/A	Mapped (90°C)	Max	Open	Oil	Controlled [*]
N/A	Non-Controlled	Max	Open	Oil	Controlled [*]
N/A	Mapped (108°C)	Max	Open	Oil	Controlled [*]
N/A	Mapped (105°C)	Max	Open	Oil	Controlled [*]
N/A	Mapped (100°C)	Max	Open	Oil	Controlled [*]

* Controlled oil flow is based on a target oil gallery pressure of 2bar

Opening temperature represents the cylinder head metal temperature (standard ECU engine temperature measure) below which engine out coolant throttle remains closed. Above this temperature the throttle will gradually open.

& EGR cooler coolant throttle was set to restrict flow in the heating loop. The opening was set according the measured flow at idle, which was measured as a percentage of the flow when the valve was fully open.

Table 3: List of all experimental setups considered and used for producing NOx response model.

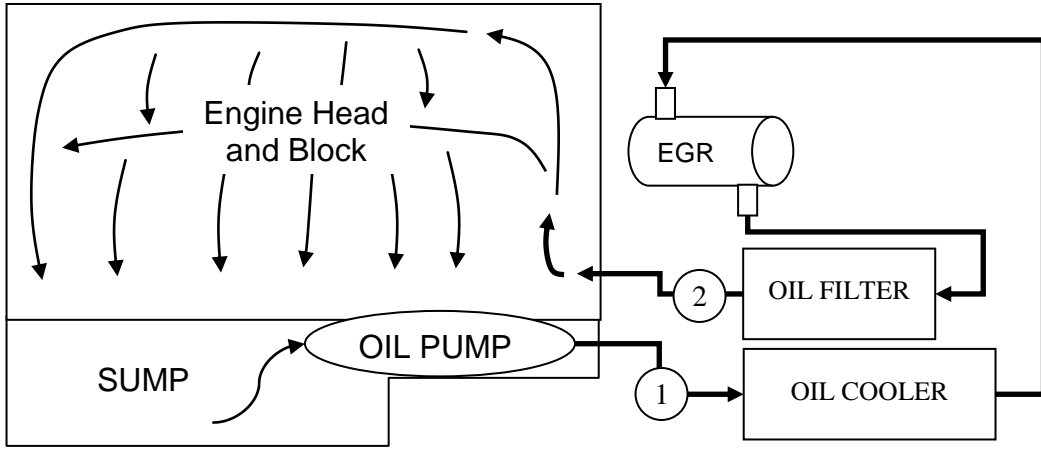

Figure 1: Modified oil circuit

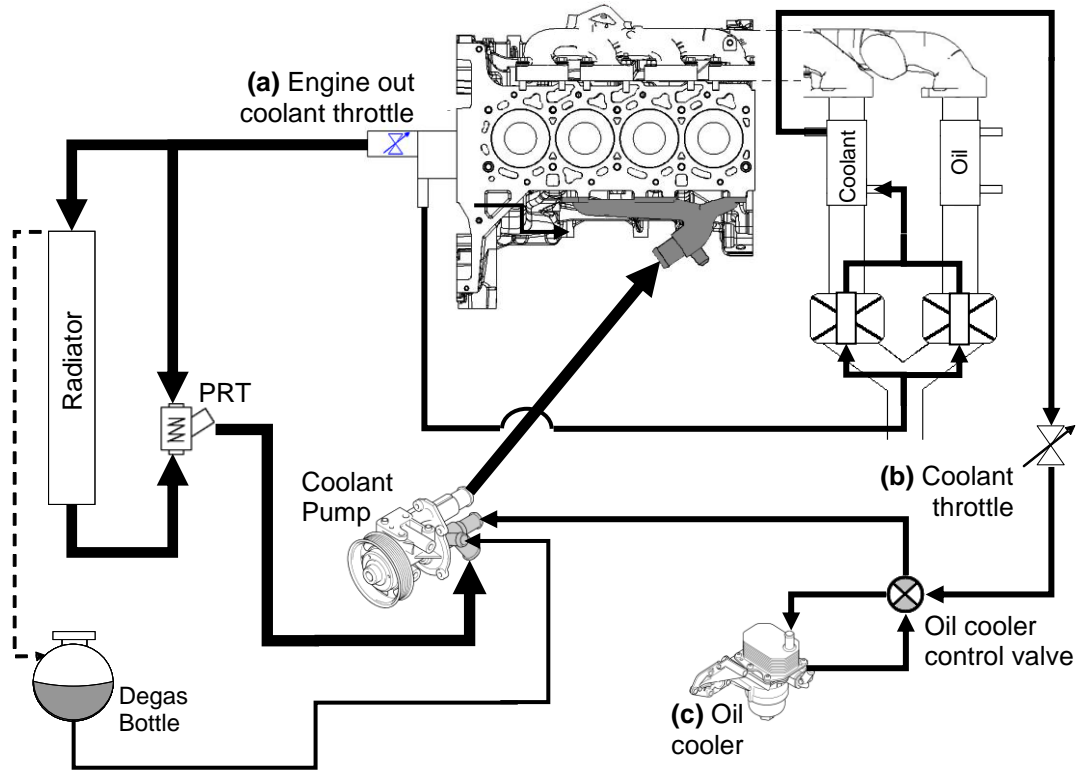

Figure 2: Modified coolant circuit

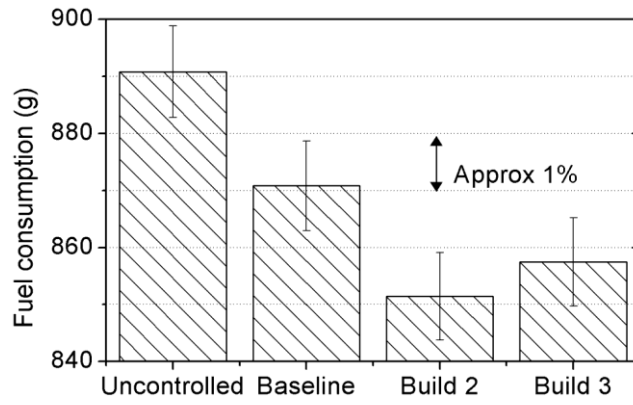

Figure 3: NEDC fuel consumption results from different engine calibration settings

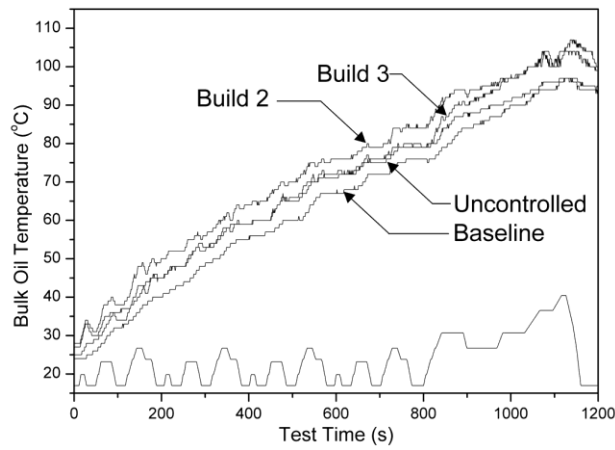

Figure 4: Bulk oil temperatures over NEDC drive cycle

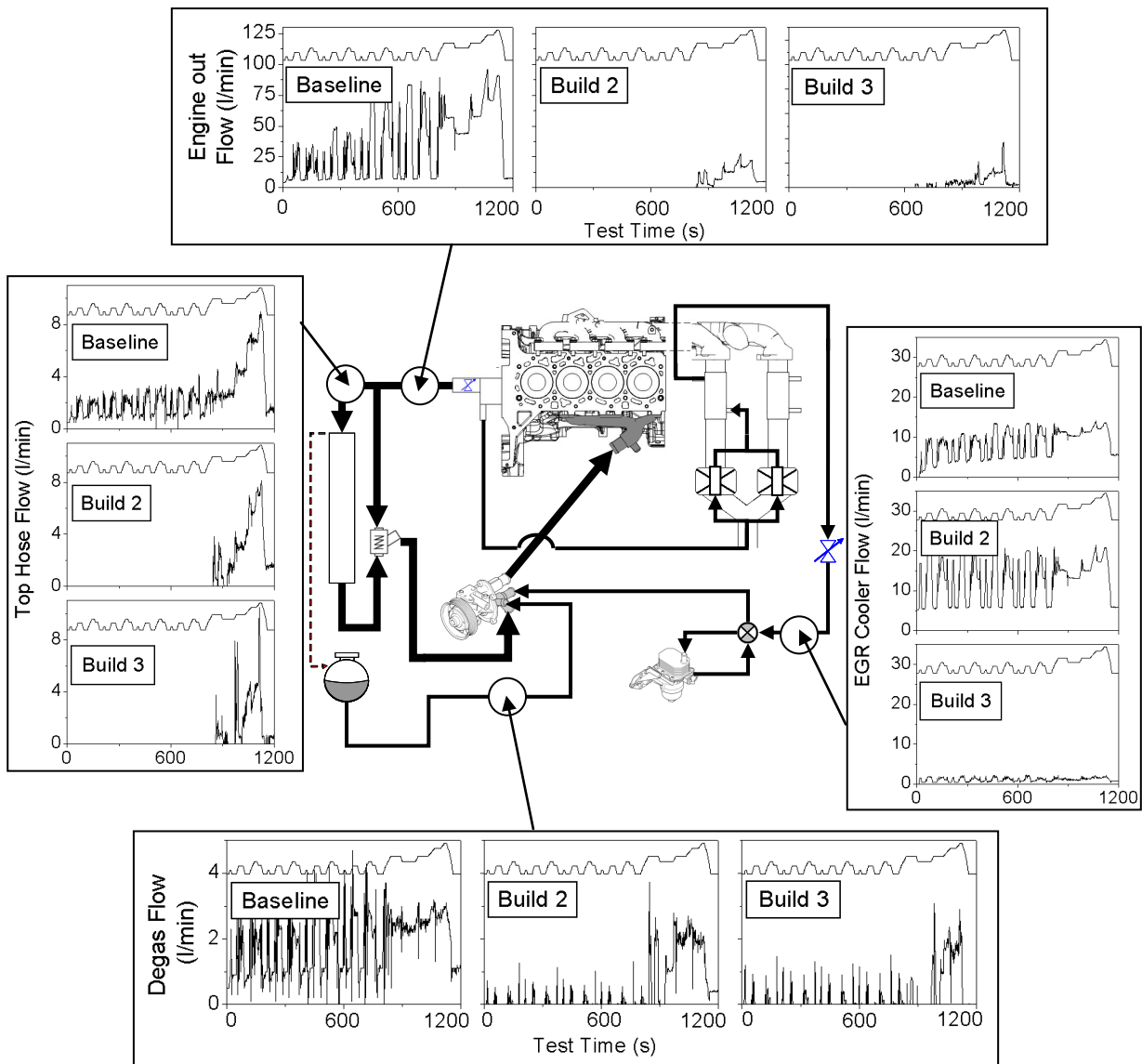

Figure 5: Coolant flow rates for baseline, build 2 and 3 at various points around the system

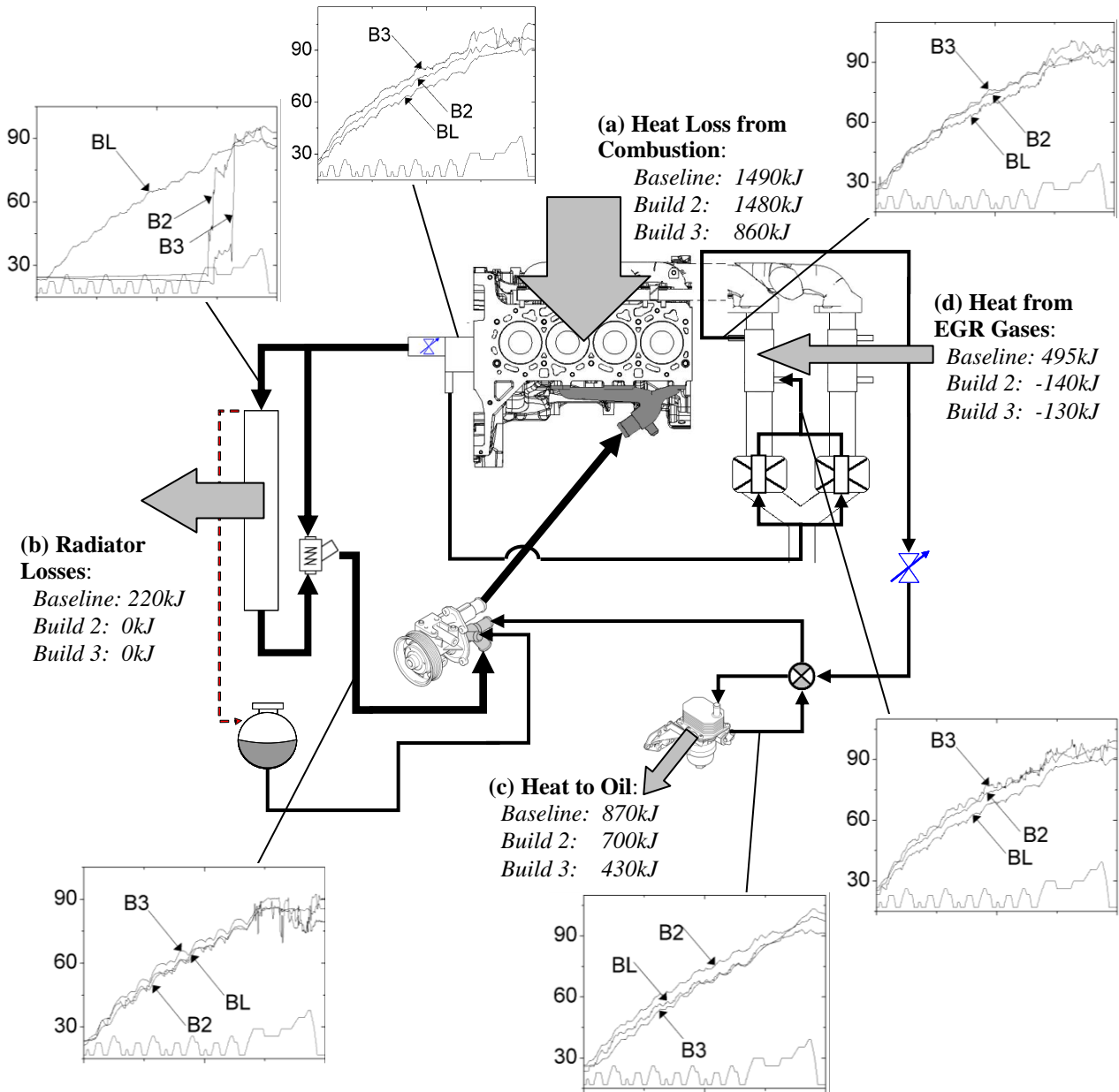

Figure 6: Cumulative energy exchanges at the end of 4th UDC cycle (after 780sec) and coolant temperatures for baseline, build 2 and 3 (all temperatures in °C)

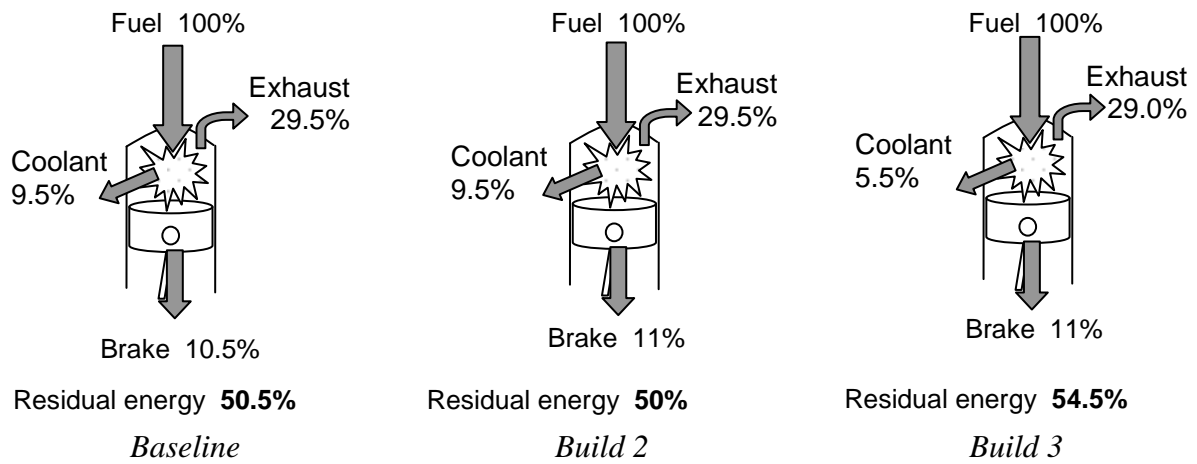

Figure 7: Mean energy flows from combustion chambers for baseline, build 2 and build 3 at end of 4th UDC (after 780 seconds)

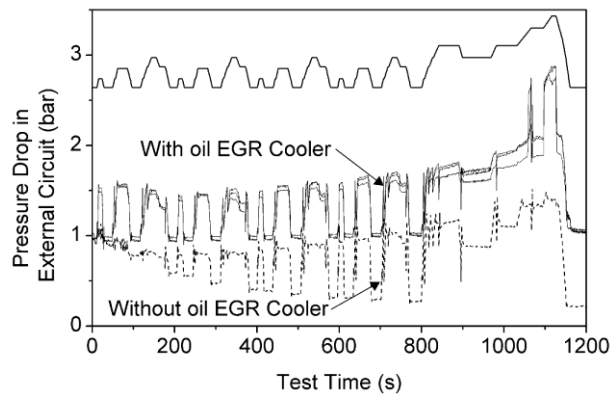

Figure 8: Oil pressure drop in external circuit with and without oil EGR cooler fitted over points 1 and 2 in oil circuit diagram

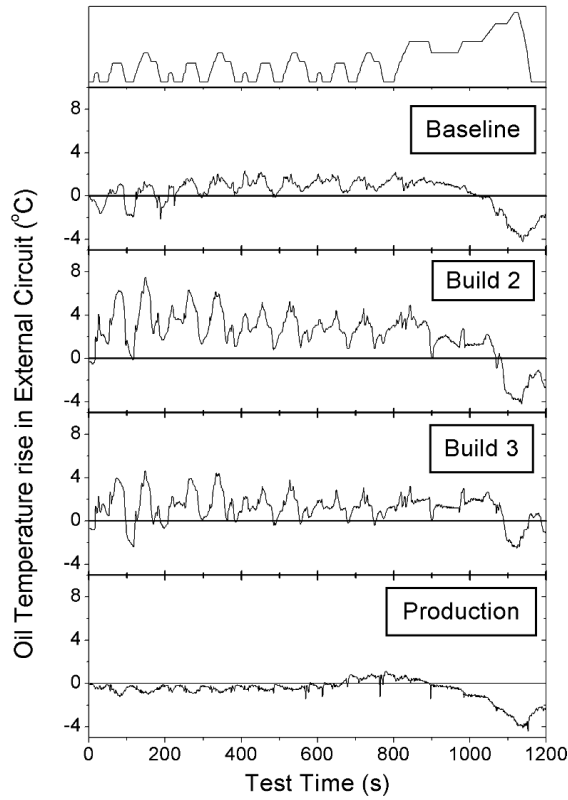

Figure 9: Oil temperature difference over external oil circuit for baseline, build 2, build 3 and production engine (without oil EGR cooler hardware) over points 1 and 2 in oil circuit diagram

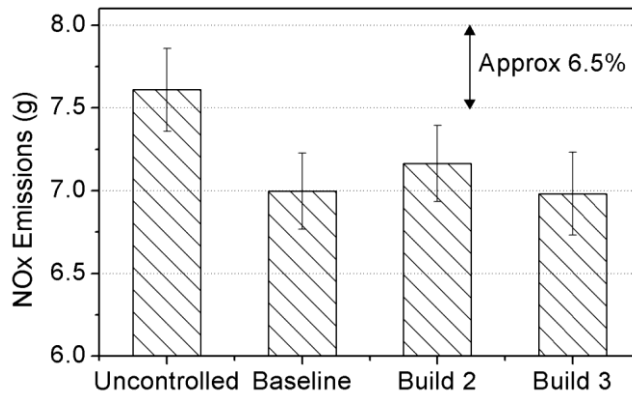

Figure 10: NEDC NO_x emissions results from different engine calibration settings

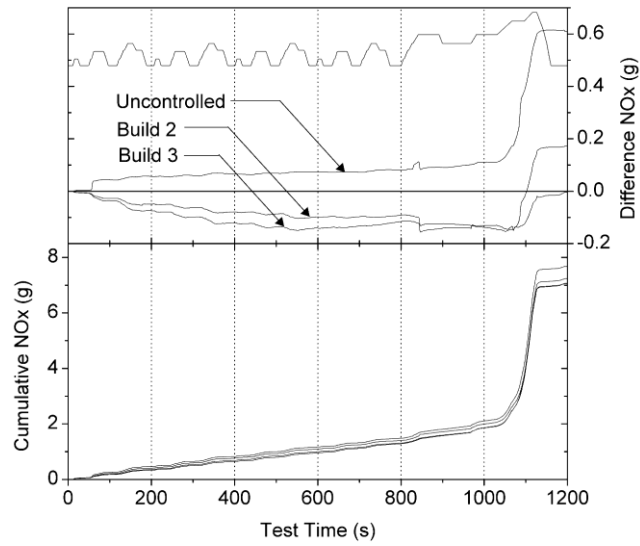

Figure 11: Cumulative NO_x and Difference to Baseline for each test over NEDC

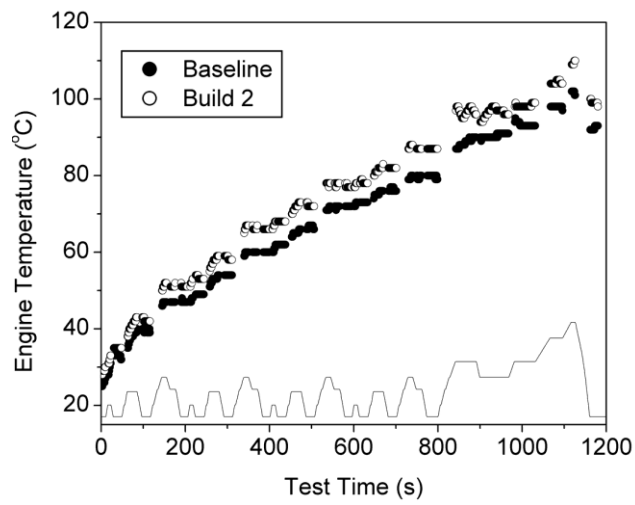

Figure 12: Engine cylinder head temperature over NEDC for baseline and build 2 (transient events have been removed for clarity)

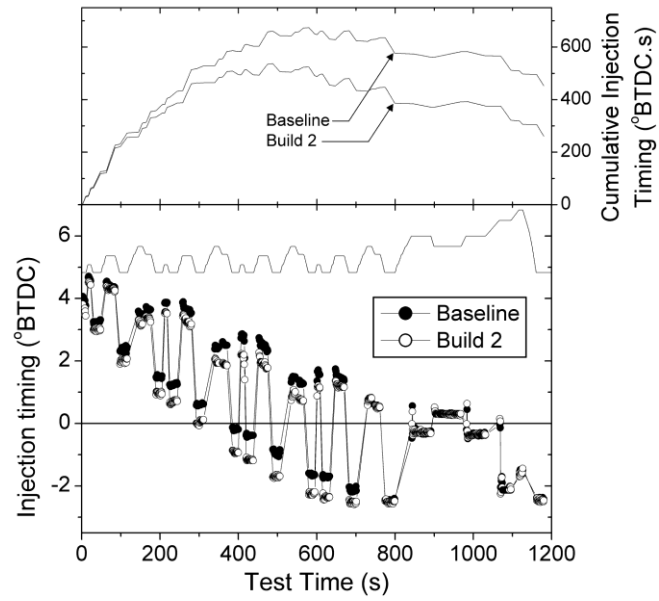

Figure 13: Injection timing comparison for baseline and build 2. Lower values indicated retarded condition (transient events have been removed for clarity)

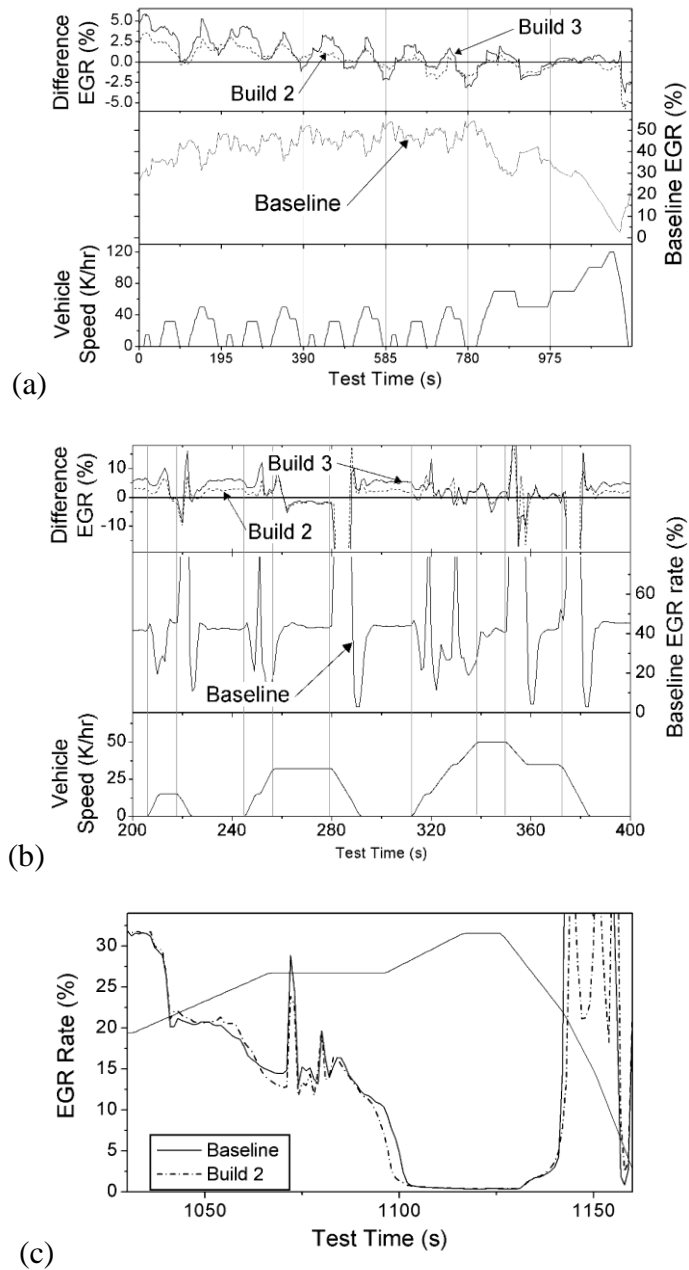

Figure 14: (a) Filtered EGR rate over NEDC cycle for baseline, and difference to baseline for builds 2 and 3; (b) Raw EGR rate over 2nd UDC for baseline and difference to baseline for builds 2 and 3; (c) Raw EGR rate over last part of EUDC for baseline and build 2. EGR rate based on ratio of inlet and exhaust CO₂ measurement.

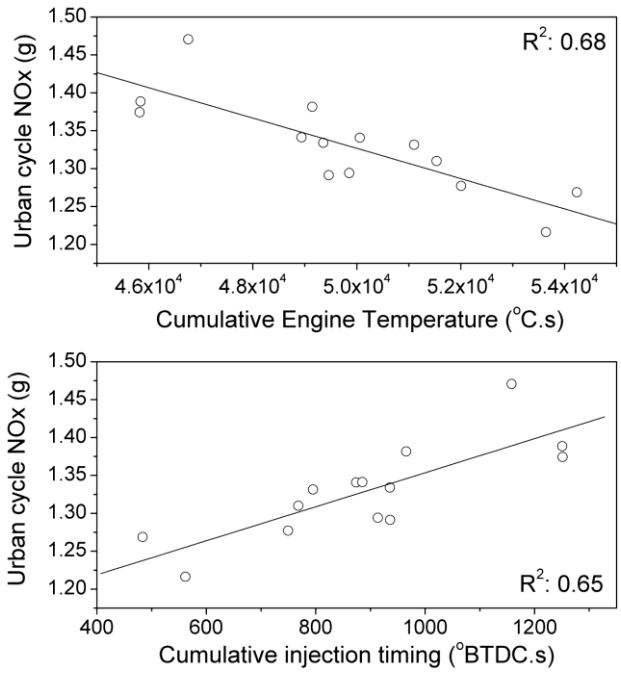

Figure 15: Urban cycle NOx correlations to engine temperature and injection timing

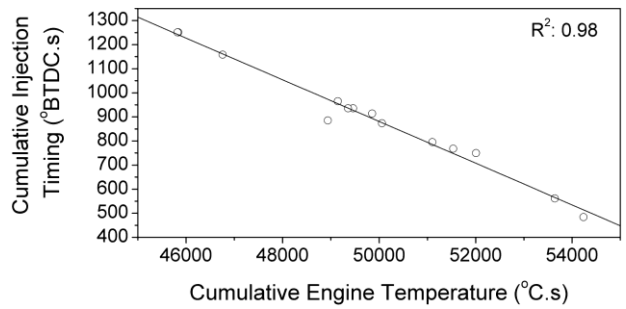

Figure 16: Correlation between injection timing and engine temperature confirming the strong link within the engine ECU

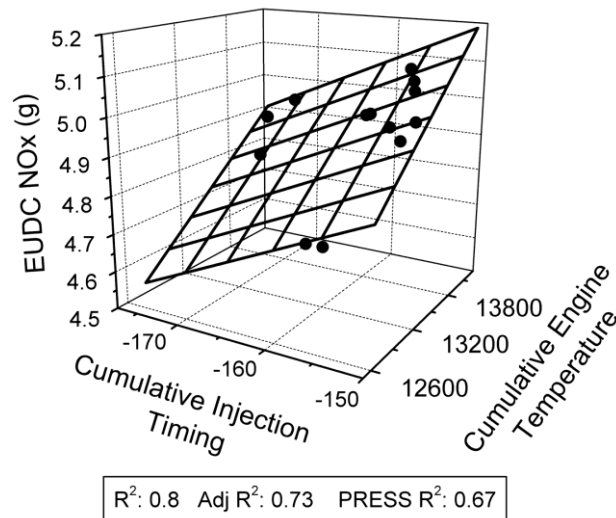

Figure 17: Response model for NO_x over 100kph and 120kph cruises of NEDC with respect to injection timing and engine head temperature at mean EGR condition. Adjusted R² and PRESS R² are measures that avoid over fitting the model to the data.

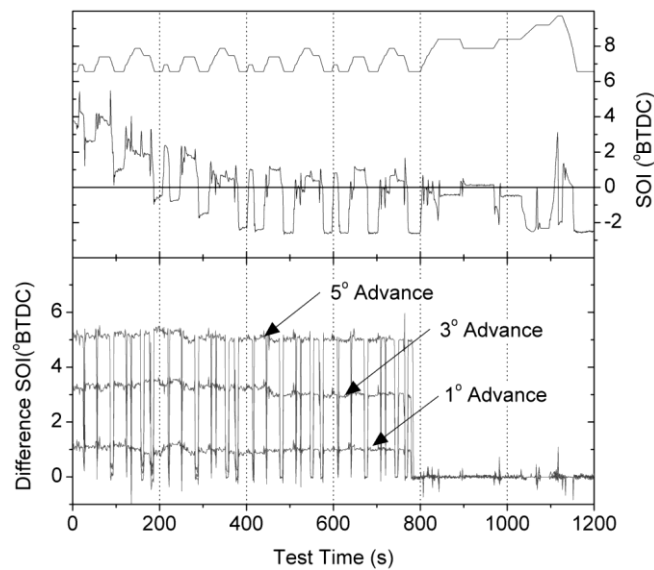

Figure 18: Start of injection (SOI) for baseline test and modified injection timings over urban section of drive cycle

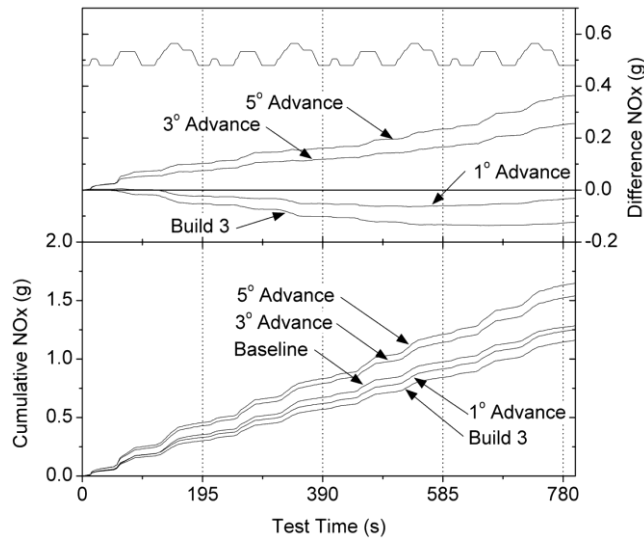

Figure 19: Cumulative NOx emissions over 4 urban cycles and difference to baseline test for each injection timing setting of Build 3

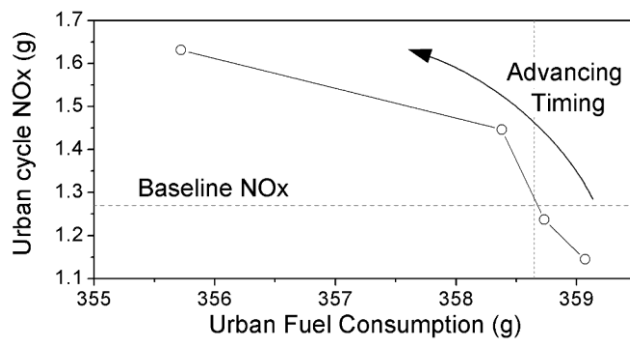

Figure 20: NOx/Fuel consumption trade off over urban cycles for varying injection timing under build 3 conditions