

*This is the authors' final version published in*

Information and Communication Technologies in Tourism 2015

The original publication is available at:

DOI: 10.1007/978-3-319-14343-9\_48

## **Distribution Channels for Travel and Tourism: The Case of Crete**

Paraskevi Fountoulaki, M. Claudia Leue, and Timothy Jung

Department of Food and Tourism Management

Manchester Metropolitan University, United Kingdom

Paraskevi.fountoulaki@stu.mmu.ac.uk; c.leue@mmu.ac.uk; t.jung@mmu.ac.uk

**Abstract** The tourism distribution channels network is extremely complex. In particular, the emergence of technologies; the development of online social networks, online review sites as well as mobile location-based services has added additional channels of distribution. The awareness of new opportunities within the tourism distribution channels is essential for tourism professional in order to remain competitive and successful. Therefore, this study aims to update the tourism distribution channels model within the context of Crete, Greece. Twenty managers from hotels and tour operators were interviewed and the data were analysed using content analysis. Interviewees identified an increased importance of social media and mobile for today's distribution market and the future decreased importance of incoming agents. Instead, the tourism industry has to start focus on Extranet/XML.

**Keywords** Tourism distribution channels, Crete, online travel agencies, traditional tour operator

### **Please cite this article as:**

Fountoulaki, P., Leue, M. C., and Jung, T. (2015). Distribution Channels for Travel and Tourism: The Case of Crete, In Tussyadiah, I. and Inversini, A. (eds), Information and Communication Technologies in Tourism, Springer International Publishing, Vienna, New York, pp. 667-680 (ISBN: 978-3-319-14342-2) DOI: 10.1007/978-3-319-14343-9\_48

# Distribution Channels for Travel and Tourism: The Case of Crete

**Abstract** The tourism distribution channels network is extremely complex. In particular, the emergence of technologies; the development of online social networks, online review sites as well as mobile location-based services has added additional channels of distribution. The awareness of new opportunities within the tourism distribution channels is essential for tourism professional in order to remain competitive and successful. Therefore, this study aims to update the tourism distribution channels model within the context of Crete, Greece. Twenty managers from hotels and tour operators were interviewed and the data were analysed using content analysis. Interviewees identified an increased importance of social media and mobile for today's distribution market and the future decreased importance of incoming agents. Instead, the tourism industry has to start focus on Extranet/XML.

**Keywords** Tourism distribution channels, Crete, online travel agencies, traditional tour operator

## 1 Introduction

Tourism distribution channels are groups of entities between tourism providers and the travellers which act as an intermediary within the purchasing process (Kracht and Wang, 2010). Advancements in technology had particularly high effects onto the way the tourism and hospitality industry operate (Kapiki, 2012; Scaglione et al., 2013). The entire industry shifted from traditional computer reservation systems; to global distribution systems and finally towards the Internet age resulting in the emergence of online travel agencies (OTAs) such as booking.com (Inversini and Masiero, 2014). Furthermore, the development of online social networks, online review sites as well as mobile location-based services has added additional channels of distribution which shifted the power of booking towards the consumer (Scaglione et al., 2013). This development from traditional booking channels towards online and social intermediaries results in the distribution network being extremely complex. Kracht and Wang (2010) conducted a theoretical study on the development of tourism distribution channels and presented an updated structure of tourism distribution channels incorporating online developments such as search engines and OTAs. However, they acknowledged that intermediaries are changing rapidly due to the fast pace in online and technological developments (Kracht and Wang, 2010). For instance, Inversini and Masiero (2014) identified that tourism businesses have to engage in social media activities in order to communicate with their customers hence, improve marketing and sales activities. Kracht and Wang (2010, p. 752) acknowledged that and stated "as new technology appears, there could be other changes in tourism distribution and Scaglione et al. (2013, p. 288) suggested that "web 2.0...requires reengineering of marketing paradigms and changes in operational business processes".

If the trends of the past are any indicator, industry participants should be prepared for additional forms of intermediation". In particular, the paper seeks to discuss the ways

to extent the channels and the influence them reflect broader aspects of tourism distribution and in an attempt to distinguish common factors from the specifics of Crete, though the range of other studies with which detailed comparisons can be made is at present extremely limited (Garin-Munoz and Perez-Amaral, 2010). Given the paucity of existing work in this field, a regional focus is taken as this provides both the scope to examine a potentially a range of different channel structures and distribution issues while at the same time keeping the fieldwork logistics manageable. Crete is a particularly appropriate focus for such a study. It is one of Greece's leading tourism regions; a region dominated by coastal tourism but also one in which online tour operators and low-cost airlines have experienced significant growth in the past decade. In addition, much of their effort goes to working with traditional tour operators. In the light of the importance of dynamic packaging, more emphasis may need to be given to this segment, particularly with the growth of low cost carriers (Garin-Munoz and Perez-Amaral, 2010).

Therefore, the present study aims to update the tourism distribution channel model by Kracht and Wang (2010) in order to identify additional forms of intermediations and account for technological developments within the online landscape. Furthermore, Buhalis and Law (2008) suggested that scholars should not only take a theoretical approach but should base their research on empirical data. Therefore, this study uses data from qualitative interviews with managers of tour operators (traditional and non-traditional), online booking/review agents and Cretan hoteliers in order to update the existing tourism distribution model thus, make it more applicable for today's tourism operations.

## **2 Literature Review**

### **2.1 Distribution Channels Model**

According to the Tourism Distribution Channels model (Kracht and Wang, 2010), the distribution system consists of consumers, online travel agents, web-able corporate travel agents, web-able tour operators, Global Distribution System (GDS) incoming travel agents, switches, destination marketing organizations (DMOs), web browser, other search engines, suppliers website and meta-search engines. GDS began in tourism industry as airline computer reservation systems (CRS) as technical electronic intermediaries (Buhalis and Licata, 2002). In the airline sector, traditional travel agents benefitted from intermediation as a result of business relationships with the GDSs such as Sabre, Galileo, Amadeus and Worldspan. GDS's airlines now collaborate with "GDS New Entrants," who are also known as "Global New Entrants," or "GNEs". These GNEs utilise Farelogix, G2 Switchworks, and ITA Software, which has been developed from the search technology of Orbitz, providing the services of GDSs at a lower price.

Within the tourism industry, the last decade has witnessed the emergence of the web as an increasingly important distribution channel for the tourism industry and the emergence of new travel eMediaries such as Orbitz, Expendia and Lastminute to name a few (Kalodikis and Yannakopoulos, 2003). The new business models being adopted by these players are essentially a combination of a merchant model with

dynamic packaging. This has effectively transformed OTAs into online tour operators thus bringing travel eMediaries in direct competition with the longer established tour operators such as TUI, MyTravel or Thomas Cook.

ITA Software provides another layer of intermediation by providing online travel agent Orbitz with meta-search engines such as Bing Travel, Fare Compare, Kayak, Side Step, GNE or Farelogix. Despite this threat, the GDSs have proven their resilience and importance within the distribution chain. Following the example of Sabre in having a stake in an online travel agency, other GDSs owners formed relationships with OTAs, just as they had with traditional agents in the past. For example, Opodo is associated with Amadeus; and Expedia is associated with World Span. With these relationships, the GDSs had re-intermediated themselves (Armstrong, 2009). Furthermore, suppliers have begun to establish webpages which connect directly with customers, therefore using the traditional retail agents' model. Moreover, traditional travel agents have been useful to hotels, the latter have also disintermediated the traditional role of travel agents by selling directly to customers via the Internet. Search engines, such as Google, first led to the intermediating role in 1998 (Flint et al., 2011). By facilitating the inception of this category of intermediaries, Internet technology set in motion a structural change that has shifted power to a new position. It can also disintermediate the developers of other web browser products, depriving them of revenues generated by searches initiated from their browsers. In this sense, the developers of web browser software have also become intermediaries within tourism distribution channels, to whom other intermediaries have to pay revenue (Claro and Claro, 2010).

From the tourism demand side, the rapid growth of travellers urges the utilisation of powerful CRSs for the administration of traffic. CRSs satisfy consumer needs for easy access and compare information on a wide variety of choices of destinations, holiday packages, travel, lodging and leisure services. They also provide immediate confirmation and speedy documentation of reservations providing a greater degree of flexibility and enabling prospective travellers to book at "last minute" (Liao and Tseng, 2008). According to Sigala (2007), there has been insufficient research in the area of incoming travel agencies using the Internet. Companies, such as Kayak, have been conceived by founders of OTAs such as Expedia, Orbitz, and Travelocity as well as other meta-search engines (Kayak.com, 2009). Electronic intermediaries are also emerging dynamically and increasingly threaten traditional distributors. For example, Lastminute.com is now challenging the business models of Thomson and Thomas Cook, forcing them to rethink their operations and strategies. The model below illustrates the development of a complex interdependent system which now exists due to the Internet.

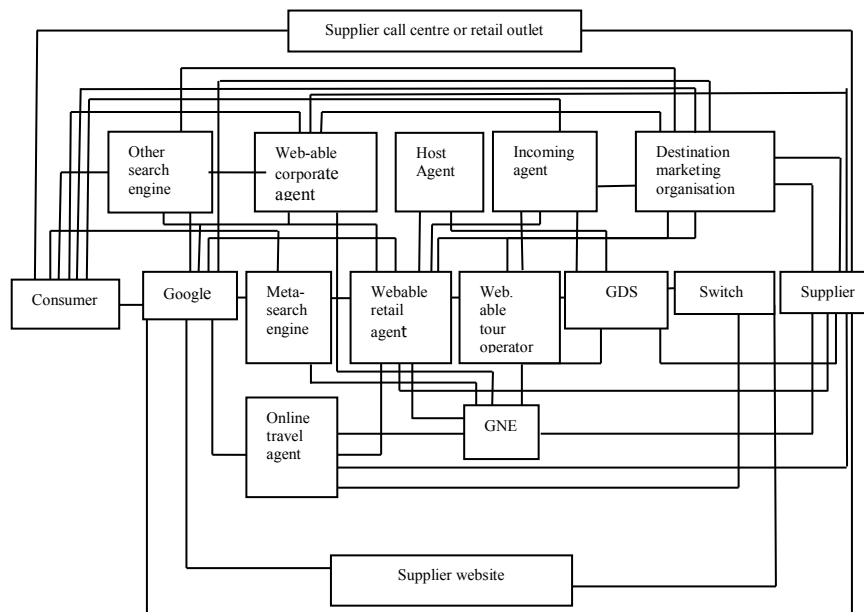

**Fig. 1. Structure of Tourism Distribution Channels (2005-2009)** (Kracht and Wang, 2010)

## 2.2 Influence of ICTs on Distribution Channels

The Internet has a global reach for the marketing of tourism products. Scholars stated that the internet provides many opportunities for the tourism industry such as an increase in choice that also closes the gap between consumers and suppliers (Berne et al. 2012; Xiang and Gretzel, 2010). Moreover, Law (2009) revealed that the technological revolution has allowed the emergence of several elements such as Computer Reservation Systems (CRS), Global Distribution Channels (GDC), and Destination Management Systems (DMS) to emerge to facilitate the distribution of tourism products. O'Connor (2010) concluded that the Internet and emerging technologies provide unprecedented tools for communication and interaction, bridging the gap between tourism suppliers and consumers on a global basis. However, according to Law (2009) current technologies are also providing travellers with far easier method of publically criticising the service levels within the hotel industry, and one example of this is Tripadvisor. Currently, electronic distribution systems are in frequent use for airlines and hotel rooms, and GDS have already started using the Internet. O'Connor, (2010) concluded that in the past few years, the Internet has significantly changed the distribution channels of the travel industry and Law (2009) agreed that the Internet has become a virtual market which requires specific communication and distribution strategies like any other market. Berne et al. (2012) acknowledged that the tourism industry is at the forefront when it comes to the effect emerging technologies have on the structure of the industry. While early adopters for new technologies often gain market share, companies that use traditional marketing

strategies are often left behind due to a lack of customisation (Berne et al., 2012). Within the tourism industry this shift of power is particularly difficult for intermediaries as the power has increasingly shifted towards the consumer (Ford et al., 2012). Therefore, intermediaries are advised to invest into e-commerce solutions to stay on the bandwagon and remain competitive (Berne et al., 2012).

Inversini and Masiero (2014) investigated the hoteliers' perspective in regards to the effect of emerging technologies and confirmed the conflict between profitability and customer relationship management. In order to be visible in today's tourism landscape it is inevitable to be present on online intermediaries such as Booking.com, to acquire new customers as well as retain existing ones. However, high commissions decrease profit margins drastically. According to Inversini and Masiero (2014), the implementation of social media into sales strategies could tackle this problem as rooms could be directly sold via hotels' own websites which again leads to disintermediation and an increase power of the consumer. Furthermore, Douglas and Lubbe (2014) assessed the increased importance of mobile technology for the tourism distribution channel market; identifying a higher growth rate than both, traditional on- and offline channels. After the explosive growth of all these technologies, extranet-XML is the next step of empowering tourism providers and consumers. According to Caber et al. (2013, p. 106), "extranets are Internet-based applications that allow external organizations access to a company's internal information". Overall, extranets improves tourism organisations' productivity as it allows an instant review of information (Caber et al., 2013).

### **3 Methods**

The purpose of the present study is to identify how the emergence of technologies has affected the Cretan tourism distribution channels structure and the role of traditional tour operators. Qualitative data collection in form of semi-structured interviews was used. Interview questions were designed based on a literature review and the following questions were mentioned in this research: what has been the biggest change in tourism distribution channels over the last 4 years; and currently, who are key players in tourism distribution channels; do you think that traditional tour operators are ready for the shift towards dynamic packaging or do you think there will be some new players turning up on the stage; are there any changes between the relationship of your business and key business partners due to the new players in distribution channels; are there any players that disappeared over the last few years.

Interviews were conducted during the ITB Berlin between 5<sup>th</sup> to 9<sup>th</sup> of March 2014. To gain a deeper understanding of the subject area, participants with at least 5 years of tourism business experience were interviewed. Therefore, non-probability and purposeful judgmental sampling was employed (Buhalis and Zoge, 2007). Twenty managers were interviewed representing all different types of Greek tour operators and hoteliers including Tripadvisor, HRS, Hotelbeds, Kuoni Group, TravelZoo, Hotelplan, YouTravel, Low Cost Holidays.com as well as a number of hoteliers from Crete. The aim of using this sample was to gather the opinion from a wide range of tour operators (traditional and non-traditional), online booking/review agents as well

as hoteliers. The data were analysed using content analysis to identify the most prominent outcomes and concepts (Buhalis and Zoge, 2007).

## 4 Findings

This section presents the content analysis of the interviews with Cretan tour operators and hoteliers. Table 1 present the codes which will be used throughout the analysis.

**Table 1. Profile of Respondents**

Code	Position	Type of company	Year of experience	Gender
BLE	Business Listing Executive	Social media	6	F
CM1	Contract Manager	OTA	11	M
CM2	Contract Manager	OTA	7	F
CM3	Contract Manager	Hotel	6	M
CM4	Contract Manager	Tour operator	17	M
DCM1	Development Contract Manager	OTA	5	M
DCM2	Development Contract Manager	Tour Operator	12	M
RCM	Regional Contract Manager	OTA	9	F
HSM1	Hotel Sales Manager	Hotel	5	F
HSM2	Hotel Sales Manager	Hotel	18	M
SM1	Sales Manager	OTA	6	F
SM2	Sales Manager	OTA	8	M
FO	Founder	Tour Operator	5	M
HGM1	Hotel General Manager	Hotel	12	M
HGM2	Hotel General Manager	Hotel	8	M
HGM3	Hotel General Manager	Hotel	12	M
HGM4	Hotel General Manager	Hotel	15	F
HRM	Hotel Front Office and Reservation Manager	Hotel	10	F
IT	IT Manager	OTA	16	M

### 4.1 The influence of dynamic packaging on traditional tour operators

Technological advancements have huge impacts on the travel distribution market all over the world. However, the situation within the Cretan tourism market is different. The Crete hoteliers and the local travel agents are trying to support more the traditional tour operators. DCM1 acknowledged the connection between traditional tour operators and enhanced online capabilities by stating that “we cannot forget that 70 percent of the sales by the traditional tour operators comes from the online systems”. The disadvantage of the island of Crete is transportation as it does not provide the possibility for independent tourism for the Cretan tourism industry as they “have a problem with flight... Crete is not a place like Spain where you can go on a round-trip as you need to travel by plane” (HSM2). He particularly emphasised that “tour operators such as TUI, Thomas Cook and Alltours as well as Thompson own the capacity of aircrafts”. In addition, CM2, the online tour operator, agreed that nowadays the entire Cretan tourism market is controlled by the big traditional tour operators as they control the market of the charter flights. Interestingly, low-cost

carriers, which are considered important carriers within Europe, have only small percentages within Crete as the majority of planes are chartered or owned by major tour operators (CM2). This example shows the immense power of tour operators exercised over the Cretan tourism market and hoteliers and displays the biggest difference to mainland destinations which are more reliant on online travel agencies. Furthermore one online travel agent, DCM1, concluded that controlling the transport acts as an insurance for traditional tour operators against online competitors. Nevertheless, HGM1 identified that the biggest change over the past four years has been that online reservations have grown up rapidly. On the other hand HSM2 stated that “we cannot ignore and stop cooperate with the traditional tour operators that have been trusted and tested through the years.... We want good partners to fill up our beds and secure our interest”. Tour operators focus on the new trends of online bookings but at the same time try to retain existing customers. HGM1 identified that “tour operators are afraid of the competition...mostly they are afraid that they will lose the traditional customers...this is the reason that why we still find printing brochures and catalogues that do not have anything to do with the online system and which are marketing tools that should not be produced anymore due to being outdated marketing techniques”. Furthermore CM4, working for a traditional tour operator, pointed out that “I don’t think that the traditional players such as tour operators can be transformed into dynamic players because of the mentality of the whole structure”.

#### **4.2 The change in key players over the last four years**

The present study aims to update the tourism distribution channels model presented in Figure 1 for the Cretan tourism context. In the tourism industry, the influence of the technology has affected traditional tour operators due to an increased demand for dynamic packaging. According to CM4 “all the traditional tour operators are following the lead of the model of booking.com because now everybody is getting online platforms... as it is the way to reduce costs and go faster and increase efficiency”. Furthermore, CM3 agreed that traditional tour operators are intrigued by the new developments in online bookings stating that “Thomas Cook has Hotels4U and TUI has Hotelbeds in an effort to get into this part of the business”. As identified above, the traditional tour operators still engage in traditional practices in order to retain existing customers however, they are trying to “adjust their program in order to catch up the new market change” (HGM1). CM2 identified that “TUI and Thomas Cook already entered the other market and they control the online side of business” which related back to the enormous power of traditional tour operators within Crete. Furthermore, the importance of online travel agents was supported by FO, the founder of an online tour operators, who stated that “technology is the biggest chance for the distribution channel market and all the time we have new channels and have to adapt our products to new challenges that we have”. Besides, he identified that “booking.com is considered the key player in the European tourism distribution channel market as sixty percent of all bookings come through booking.com.

#### **4.3 The change in relationship between tour operators and hoteliers**

As expected, the influence of social media has changed how travellers access and book tourism products. CM1, contract manager of one of the online booking engines,



supported the importance of social media by identifying that they had to integrate their booking engines via Facebook in order to account for the increased demand on these networks. In addition, CM4 acknowledged that “everybody goes through these channels (Facebook and Twitter) and they influence a lot of the market”. This also affects the way hotels receive bookings as customers can directly access hotels’ own website from social media links which reduces commissions. However, HSM2 rejected this point of view and raised his concern saying that “I do not think that new players in the market such as Tripadvisor or Holidaycheck can interfere their sales business of traditional online operators...We cannot compare them with booking.com, Expedia” as they do not have the influence on the reservation at the moment. SM2, sales manager of an online tour operator specialising in deals and packages, pointed out that “the direction we are going in the future is social media and mobile phones”. This was supported by SM1 who identified that “iPhone is growing and many customers can book their holidays through mobile devices”. It is important to mention that “you can book a room in the morning and you can go and stay there in the evening”. CM3 acknowledged that “you can have the client in the reception booking or you can have them in front of you five minutes after booking”. Nevertheless, this phenomenon might again be more likely on the mainland as holidays on an island are normally less spontaneous and require some planning. One hotel contracts and sales manager, HSM2, pointed out that there is a new application that TUI adopted saying “You can do all the business from the day you decide to go for holiday until the departure through your mobile”.

#### **4.4 The influence of ICTs onto the tourism distribution channel structure**

Four participants (SM2, SM1, CM4, RCM) agreed that the local travel agencies will disappear. CM4 identified that there is a big problem for incoming/local travel agencies as they are being pushed out of the market in order to reduce costs. Furthermore, “if the platform or the online tour operator has direct access to hoteliers or to the customer making the booking online then they will disappear or they will be only content management companies feeding their systems and be located somewhere let’s say in India”. RCM mentioned that TUI provides hoteliers with their own administration rights so that they are able to change rates and have direct relationship with the tour operators and the customers. RCM furthermore forecasted that the future trend will be B2C as there will be no more brokers and the customer will directly make their own reservations, book transport and excursions all on one site. Furthermore, HGM2 believes that hotels in Crete will have increased power in the future in terms of marketing strategies and bookings which changes the distribution channels model. SM1 agreed that hotels nowadays use hotel-manager software such as travelclick.com for selling their rooms. In addition, SM2 identified that hoteliers are nowadays enabled to control themselves with travel window use so it makes it a “free experience” for all parties. Figure 2 presents the updated tourism distribution channels model for the Cretan tourism context from 2010 to 2014, representing how the tourism distribution channels market works at the moment. Figure 3 looks a bit further and shows the future structure of tourism distribution channels in Crete. The biggest change is the disappearance of incoming agents and the appearance of Extranet-XML which is considered one of the biggest changes in the future Cretan

tourism distribution channel market according to interviewees (CM4, RCM, HGM2, SM1, SM2).

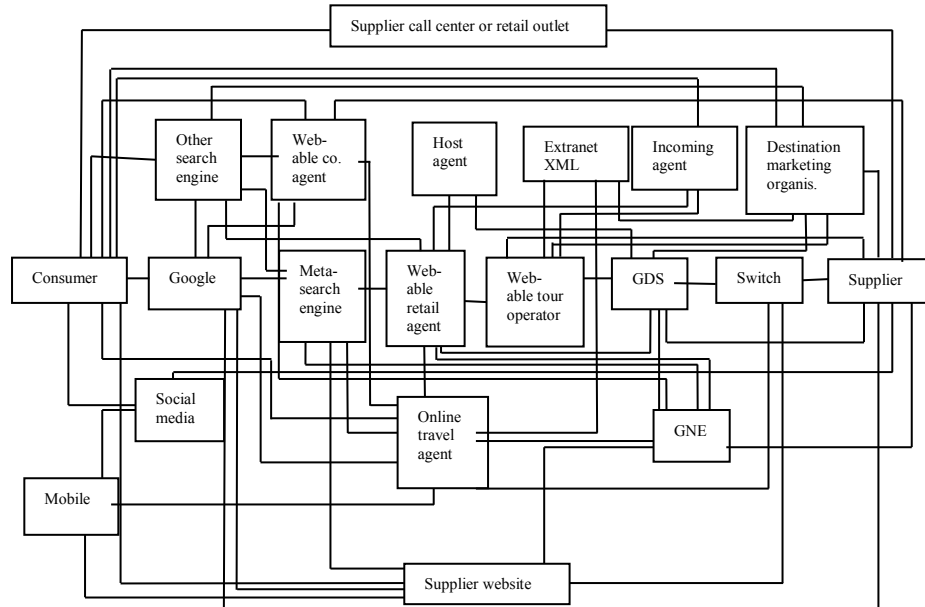

**Fig. 2. Structure of Tourism Distribution Channels (2010-2014)**

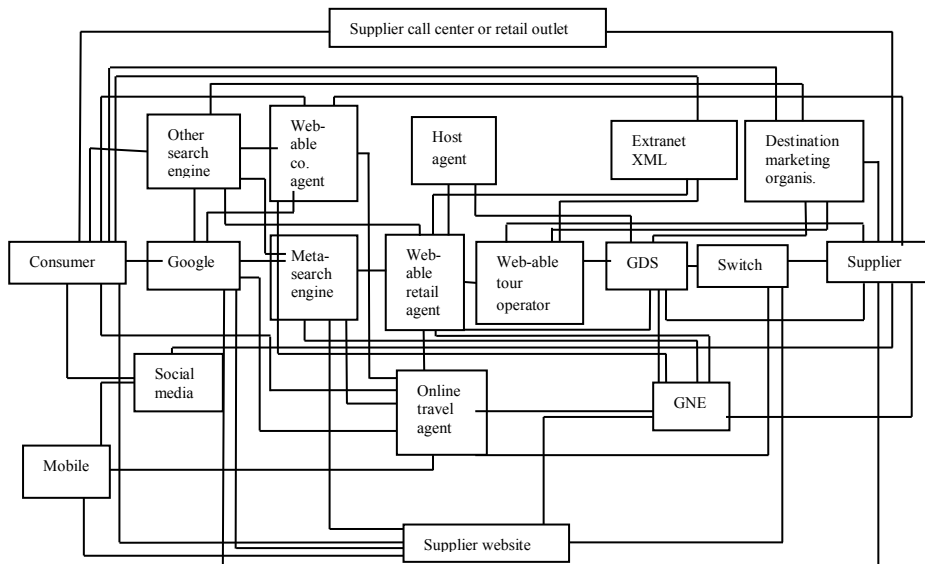

**Fig. 3. Structure of Tourism Distribution Channels in the Future**

## **5 Discussion and Conclusion**

This study has shown that within the last 4 years the biggest change within the tourism distribution channels were that social media connects with the online travel agencies and the suppliers' website (Lee et al., 2013). The recent recognition of the importance of distribution as a source of competitive advantage in the marketing mix for tourism is not considered sufficient. A more strategic approach to tourism distribution is needed by Cretan hotel owners and managers. The implementation of selling technologies within the accommodation environment can enhance the dynamic characteristics and predisposition of travel agencies and tour operators towards social media (Hsu, 2012; Fuchs et al., 2008; Schegg and Scaglione 2014). In addition, more and more customers use mobile applications to access tour operators and airline companies. Furthermore, hoteliers through the Extranet or Suppliers Extra can build direct relationship with their suppliers (tour operators) without the necessity for intermediaries. Hoteliers can enter into the online arena taking care of online sales as well as online communication and marketing which provides them with increasingly more power. This is particularly true as a professional, coherent and consistent presence both on online selling channels and online discussion and review channels will foster sales (Carroll and Siguaw, 2003). This result suggests a different underlying perception of hoteliers towards the two online technologies, in which Hotel Management Software to be related to hotel capacity (e.g. an effective instrument for increasing the occupancy rate as much as possible) and direct relationship with the suppliers and the customers.

### **5.1 Theoretical and Practical Implications**

Technological advancements change the tourism distribution channels on a regular basis. However, there is limited previous research which updated the tourism distribution channels model, particularly within the Cretan context. Therefore, the proposed model, which is based on key players within the Cretan tourism context, adds to the academic pool of knowledge. Furthermore, this study identified the importance of Extranet-XML for the future of tourism distribution channels supporting Caber et al. (2013). Extranets use Internet technology to communicate between suppliers and customers. Tourism Extranet supports all business dealings with external users and partners, in particular the management of tourism contracts between tour operators and hoteliers. In addition, Cretan hoteliers are losing market share in favour of independently organised tourism facilitated using dynamic packages. At the same time, the results of interviews revealed that incoming agents will disappear. Furthermore, the importance of mobile devices and social media for platforms such as Tripadvisor was confirmed within this study.

For practitioners, the updated model as well as the future model show opportunities and areas to focus marketing strategies on which confirms previous research by Scaglione et al. (2013). Understanding the tourist behaviour is important to travel suppliers and tourism authorities for formulating effective marketing strategies and policies, in order to fully exploit the potential of new and emerging channels. This complexity presents many challenges to all those involved in marketing travel and tourism as well as to tourism researchers.

## 5.2 Limitations and Future Research

There are a number of limitations within the present study. The customer perspective is important to identify in the future because they provide more information than the travel professionals for the sustainability of the intermediaries. Further research in different geographical and touristic contexts is encouraged in order to support the findings and provide a wider generalisability of the results. In addition, in order to increase the reliability and enhance generalisability, future research could use a quantitative approach in order to gather data from a wider population. Furthermore, with the rapid development of technologies, it is essential to update the tourism distribution channels model on a regular basis. The emergence of wearable computing such as smart watches and Google Glass will affect the way tourism businesses operate in the future thus, future research might investigate their effect on tourism distribution channels.

## References

- Armstrong, G. (2009). *Marketing: an introduction*. Harlow, England: Financial Times Prentice Hall.
- Berne, C., Garcia-Gonzales, M. & Mugica, J. (2012). How ICT shifts the power balance of tourism distribution channels. *Tourism Management* 33 (1): 205-214.
- Buhalis, D. & Licata, M. (2002). The future eTourism intermediaries. *Tourism Management* 23(3): 207-220.
- Buhalis, D. & Law, R. (2008). Progress in information technology and tourism management: 20 years on and 10 years after the internet – The state of eTourism research. *Tourism Management* 29: 609-623.
- Buhalis, D. & Zoge, M. (2007). The Strategic Impact of the Internet on the Tourism Industry. In: M. Sigala, L., Lich, & J. Murphy (Eds.), *Information and Communication Technologies in Tourism 2007* (pp. 481-492), Vienna, Springer.
- Caber, M., Albayrak, T., & Loiacono, E. T. (2013). The Classification of Extranet Attributes in Terms of Their Asymmetric Influences on Overall User Satisfaction An Introduction to Asymmetric Impact-Performance Analysis. *Journal of Travel Research* 52(1): 106-116.
- Carroll, B. & Siguaw, J. (2003). The evolution of electronic distribution: effects on hotels and intermediaries. *Cornell Hotel and Restaurant Administration Quarterly* 44(4): 38-50.
- Claro, D., & Claro, P. (2010). Collaborative buyer - supplier relationships and downstream information in marketing channels. *Industrial Marketing Management*, 39(2): 221-228.
- Douglas, A. & Lubbe, B. (2014). Mobile Devices as a Tourism Distribution Channel: Perceptions of Visitors to National Parks in South Africa. In: Z. Xiang, & I. Tussyadiah (Eds.), *Information and Communication Technologies in Tourism 2014* (pp. 855-867), Vienna, Springer.
- Ford, R.C., Wang, Y. & Vestal, A. (2012). Power asymmetries in tourism distribution networks. *Annals of Tourism Research* 39 (2): 755-779.
- Flint, D. J., Blocker, C. P., & Boutin Jr, P. J. (2011). Customer value anticipation, customer satisfaction and loyalty: An empirical examination. *Industrial Marketing Management* 40(2), 219-230.
- Fuchs, M., Höpken, W. Eybl, A. & Ulrich, J. (2008). Online Auctions for Selling Accommodation Packages A Readiness-Intensity- Impact Analysis. In Z. Xiang & I. Tussyadiah (Eds.). *Information and Communication Technologies in Tourism*. Springer International Publishing (pp. 813-826)

- Garin-Munoz, T. & Perez-Amaral, T. (2010). Internet Usage for Travel and Tourism. The Case of Spain, Paper presented at 21st European Regional ITS Conference, Copenhagen (pp. 2-22).
- Hsu, Y. L. (2012). Facebook as international eMarketing strategy of Taiwan hotels, *International Journal of Hospitality Management* 31(3): 972-980.
- Inversini, A. & Masiero, L. (2014). Selling rooms online: the use of social media and online travel agents. *International Journal of Contemporary Hospitality Management* 26(2): 272-292.
- Kalodikis, G. & Yannakopoulos, P. (2003), ICT Contribution in Establishing a Competitive Advantage for the Greek Tourism Industry, available at: [ikaros.teipir.gr](http://ikaros.teipir.gr) (Accessed July 30, 2014).
- Kapiki, S. (2012), Current and Future Trends in Tourism and Hospitality. The Case of Greece. *International Journal of Economic Practices and Theories* 2 (1): 1-12.
- Kayak.com (2009), Corporate Backgrounder – Kayak, available at: [www.kayak.com](http://www.kayak.com) (accessed October 28, 2009).
- Kracht, J., & Wang, Y. (2010). Examining the tourism distribution channel: evolution and transformation. *International Journal of Contemporary Hospitality Management* 22(5): 736-757.
- Kim, J. & Connolly D. J. (2012). Hospitality in the age of customer empowerment. First Annual Customer Engagement Technology Study, *Hospitality Technology*. <http://luiscode.files.wordpress.com/2012/09/customer-engagement2012.pdf> (accessed May 29, 2013).
- Law, R. (2009). Disintermediation of hotel reservations: the perception of different groups of online buyers in Hong Kong. *International Journal of Contemporary Hospitality Management* 21(6): 766-772.
- Lee, H., Guillet, B.D. & Law, R. (2013). An examination of the relationship between online travel agents and hotels a case study of choice hotels international and Expedia.com. *Cornell Hospitality Quarterly* 54 (1): 95-107.
- Liao, C. H. & Tseng P. L., (2008) Strategic Selection of Direct Selling and Private Brand in Retail Market under Manufacturer Stackelberg, *Journal of Management* 25: 467-485.
- O'Connor, P. (2010). Managing a hotel's image on TripAdvisor. *Journal of Hospitality Marketing & Management* 19(7):754-772.
- Sigala, M. (2007). Investigating the Internet's impact on interfirm relations. Evidence from the business travel management distribution chain. *Journal of Enterprise Information Management* 20(3): 335-355.
- Scaglione, M., Schegg, R. & Tranichet, J. (2013). Analysing the Penetration of Web 2.0 in Different Tourism Sectors From 2008 to 2012. In. L. Cantoni & Z. Xiang (Eds.). *Information and Communication Technologies in Tourism* (pp. 280-289), Vienna, Springer.
- Scaglione, M. & Schegg, R. (2014). Substitution Effects Across Hotel Distribution Channels. In. Z. Xiang & I. Tussyadiah (Eds.). *Information and Communication Technologies in Tourism* (pp.801-812), Vienna, Springer.
- Xiang Z. & Gretzel U. (2010). Role of social media in online travel information search. *Tourism Management* 31: 179-188.