

*Energies* **2015**, *8*, 8391-8405; doi:10.3390/en8088391

OPEN ACCESS

*energies*

ISSN 1996-1073

[www.mdpi.com/journal/energies](http://www.mdpi.com/journal/energies)

Article

## Study of Power Flow Algorithm of AC/DC Distribution System including VSC-MTDC

Haifeng Liang \*, Xiaoling Zhao, Xiaolei Yu, Yajing Gao and Jin Yang

State Key Laboratory of Alternate Electrical Power System with Renewable Energy Sources  
(North China Electric Power University), Baoding 071003, Hebei, China;  
E-Mails: [xiaoling\\_12345@163.com](mailto:xiaoling_12345@163.com) (X.Z.); [yuxiaolei818@163.com](mailto:yuxiaolei818@163.com) (X.Y.);  
[51351706@ncepu.edu.cn](mailto:51351706@ncepu.edu.cn) (Y.G.); [j.yang8@aston.ac.uk](mailto:j.yang8@aston.ac.uk) (J.Y.)

\* Author to whom correspondence should be addressed; E-Mail: [hfliang@ncepu.edu.cn](mailto:hfliang@ncepu.edu.cn);  
Tel.: +86-139-3085-6912.

Academic Editor: Hossam A. Gabbar

Received: 13 June 2015 / Accepted: 3 August 2015 / Published: 7 August 2015

---

**Abstract:** In recent years, distributed generation and a large number of sensitive AC and DC loads have been connected to distribution networks, which introduce a series of challenges to distribution network operators (DNOs). In addition, the advantages of DC distribution networks, such as the energy conservation and emission reduction, mean that the voltage source converter based multi-terminal direct current (VSC-MTDC) for AC/DC distribution systems demonstrates a great potential, hence drawing growing research interest. In this paper, considering losses of the reactor, the filter and the converter, a mathematical model of VSC-HVDC for the load flow analysis is derived. An AC/DC distribution network architecture has been built, based on which the differences in modified equations of the VSC-MTDC-based network under different control modes are analyzed. In addition, corresponding interface functions under five control modes are provided, and a back/forward iterative algorithm which is applied to power flow calculation of the AC/DC distribution system including VSC-MTDC is proposed. Finally, by calculating the power flow of the modified IEEE14 AC/DC distribution network, the efficiency and validity of the model and algorithm are evaluated. With various distributed generations connected to the network at appropriate locations, power flow results show that network losses and utilization of transmission networks are effectively reduced.

**Keywords:** voltage source converter; MTDC; distribution systems; mathematical model; interface functions; back/forward iterative algorithm

---

## 1. Introduction

In recent years, the economic development and the fast speed of the urbanization process causes the power consumption to grow rapidly. Therefore, the traditional distribution systems are facing a series of challenges, e.g. increasing operation efficiency, enhancing service reliability, improving power quality and safe-interconnecting distributed generation [1–4]. The VSC-HVDC [5–8] technology based voltage source converter shows advantages because of the rapidly growing applications of power electronics technology in the electricity distribution field: (1) distributed generation (DG) and energy storage (ES) devices interfaced to the AC distribution network require DC/AC or AC/DC conversion while a complete DC network can save lots of converter links and reduce costs and power losses but improve operational flexibility [9–11]; (2) AC distribution networks require AC/DC conversion which supplies a growing number of DC loads—a DC distribution network can eliminate the links which will greatly reduce energy conservation [12,13]; (3) urbanization and the extensive use of power-electronic devices cause voltage fluctuations, voltage dips, harmonic pollution and other power quality problems in AC distribution networks [2–4]. Studies also show that DC distribution networks have lots of other advantages: environmentally friendly, high capacity of power supply, low-cost of distribution cables and lines, reduced transmission utilization and losses, improved power quality, and needing no reactive power compensation [1,12,13].

Considering the comprehensive advantages of the DC distribution network, considering the huge investment into development of independent DC distribution networks, the use of a hybrid AC/DC distribution scheme then gradually transiting to a complete DC distribution system is more feasible in practice. Therefore, an AC/DC power distribution system based on VSC-MTDC cannot only realize independent control of active and reactive power, but also improve the power quality and power supply capacity of the distribution network, facilitate the DG connection, and reduce losses and costs. The study of the power flow calculation method of the AC/DC distribution system with VSC-MTDC will be an important basis to analyze the steady-state and transient characteristics, control and protection technologies of VSC-MTDC. Therefore, it will be the main focus of this paper.

At present, the research on the modeling and control algorithms already has made some achievements for the AC/DC transmission system with VSC-HVDC, but the study of the AC/DC distribution system with VSC-MTDC is still in its infancy. Alternating iterative algorithms or unified iterative algorithms are commonly applied to the problem of power flow calculation for the VSC-MTDC system [14–16]. Among reported works, in [17], based on a steady-state model of VSC-HVDC, a mathematical model based on Newton method power flow calculation was developed and then a power flow algorithm was proposed which calculate AC and DC alternately. In [18], considering different control modes of VSC, correction equations were derived. On the basis of these correction equations, a uniform iterative power flow calculation algorithm for systems equipped with VSC-HVDC was proposed. In [19], under fixed control parameters and fixed power flow control objectives, respectively, a novel algorithm for power

flow calculation based on equivalent injection power was proposed. In [20,21], a VSC model for VSC-MTDC power flow calculation was derived. According to the combinations for control variables  $M$  (modulation degree) and  $\delta$  (PWM phase angle), four kinds of control schemes were brought forward; and corresponding interface functions for AC/DC alternant calculation are provided. In all the above research, converter losses are treated as equivalent to a resistance or simply ignored. To assume that the active flow through the converter is equal to the DC power flow means that the calculation under this assumption is not accurate enough. In [22], a generalized alternating iterative power flow algorithm for AC/DC networks suitable to different converter control modes is proposed. In [23], the converter losses model is studied in detail prior to proposing an alternating iterative power flow algorithm for AC/DC network incorporating VSC-MTDC which is compatible with other existing commercial AC power flow calculation software.

In this paper, considering the losses of reactor, the filter and the converter, a mathematical model of VSC-HVDC is derived. After building AC/DC distribution network architecture, the differences in the modified equations of the VSC-MTDC-based network under different control patterns are analyzed. In addition, corresponding interface functions under five control patterns are provided, and a back/forward iterative algorithm is proposed. Finally, by calculating the power flow of a modified IEEE14 AC/DC distribution network, the efficiency and validity of the model and algorithm are evaluated. With different distributed generations connected to the network at different yet appropriate locations, power flow results show that network losses and power absorption from transmission networks are reduced.

## 2. Theoretical Considerations

### 2.1. VSC-HVDC Steady-State Model

The voltage source converter based high voltage direct current (VSC-HVDC) model is shown in Figure 1.

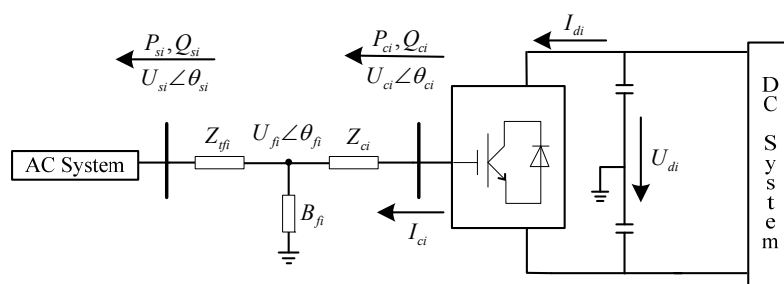

**Figure 1.** Model of VSC-HVDC.

In Figure 1, it is assumed that parameters with subscript  $i$  are those of the  $i$ th VSC generated from the DC system. Its AC output voltage is  $\dot{U}_{ci} = U_{ci} \angle \theta_{ci}$  and the connected AC system voltage  $\dot{U}_{si} = U_{si} \angle \theta_{si}$  with PWM phase angle  $\delta_i = \theta_{ci} - \theta_{si}$ . The connected filter voltage is  $\dot{U}_{fi} = U_{fi} \angle \theta_{fi}$  and the DC voltage is  $U_{di}$ . The impedance of interface transformer is  $Z_{tfi} = R_{tfi} + jX_{tfi}$  and impedance of reactor is  $Z_{ci} = R_{ci} + jX_{ci}$  while the susceptance of filter is  $jB_{fi}$ . The power injected to AC system is  $P_{si}$ ,  $Q_{si}$ , and the power from the interface transformer is  $P_{ci}$ ,  $Q_{ci}$  while the DC power is  $P_{di}$ . The steady state model of VSC-HVDC is derived as follows [23].

$$P_{si} = -U_{si}^2 G_{fi} + U_{si} U_{fi} [G_{fi} \cos(\theta_{si} - \theta_{fi}) + B_{fi} \sin(\theta_{si} - \theta_{fi})] \quad (1)$$

$$Q_{si} = U_{si}^2 B_{fi} + U_{si} U_{fi} [G_{fi} \sin(\theta_{si} - \theta_{fi}) - B_{fi} \cos(\theta_{si} - \theta_{fi})] \quad (2)$$

$$P_{ci} = U_{ci}^2 G_{ci} - U_{fi} U_{ci} [G_{ci} \cos(\theta_{fi} - \theta_{ci}) - B_{ci} \sin(\theta_{fi} - \theta_{ci})] \quad (3)$$

$$Q_{ci} = -U_{ci}^2 B_{ci} + U_{fi} U_{ci} [G_{ci} \sin(\theta_{fi} - \theta_{ci}) + B_{ci} \cos(\theta_{fi} - \theta_{ci})] \quad (4)$$

Considering the converter losses of VSC  $P_{lossi}$ , the relationship between  $P_{di}$  and  $P_{ci}$  can be expressed as

$$P_{di} = P_{ci} + P_{lossi} \quad (5)$$

where, with reference to [24,25],  $P_{lossi}$  is made up of constant and variable part. In this paper, it is revised to include constant, linear and quadratic square part. Among them, the circuit loss associated with the off-state voltage of device is described as constant and loss and switching loss associated with the current state relationship as linear, while reverse recovery loss and generated heat loss as quadratic square part of the current  $I_{ci}$  [23].

$$P_{lossi} = a + bI_{ci} + cI_{ci}^2 \quad (6)$$

where,  $a$ ,  $b$ ,  $c$  are the loss coefficient determined by the curve which is fitted by the test data of the converter losses of VSC. Moreover, the following expression can be obtained.

$$U_{ci} = \frac{\mu M_i}{\sqrt{2}} U_{di} \quad (7)$$

where,  $M$  is the modulation degree of PWM and  $\mu$  is DC voltage utilization.

## 2.2. VSC-HVDC Control Modes and Parameter Constrains

In VSC-HVDC, the stability of the DC voltage is directly related to the normal operation of the system and the stability of the output voltage at the AC-side. In order to achieve the balance of power, one of the VSC control objective is constant DC voltage control. There are four basic control modes for VSC-HVDC:

- Mode 1: Constant active and reactive power control;
- Mode 2: Constant active and AC voltage amplitude control;
- Mode 3: Constant DC voltage and reactive power control;
- Mode 4: Constant DC voltage and AC voltage amplitude control.

In an AC/DC distribution system, the above control modes are also required, but when connected to a passive system, the power value cannot be determined which can only be obtained from the power flow calculation of the passive system. So, a mode 5 is proposed for connection to passive systems where the control mode is constant AC voltage (amplitude and phase). In power flow calculations, parameter constraints are listed as follows.

$$U_{s \min} \leq U_s \leq U_{s \max} \quad (8)$$

$$\theta_{s \min} \leq \theta_s \leq \theta_{s \max} \quad (9)$$

$$Q_{s \min} \leq Q_s \leq Q_{s \max} \quad (10)$$

$$U_{d\min} \leq U_d \leq U_{d\max} \tag{11}$$

$$P_d \leq P_{dN} \tag{12}$$

$$0 \leq P_{DG} \leq P_{DG\max} \tag{13}$$

$$0 < M \leq 1 \tag{14}$$

where,  $U_{s\min}$ ,  $U_{s\max}$ ,  $\theta_{s\min}$ ,  $\theta_{s\max}$ ,  $Q_{s\min}$ , and  $Q_{s\max}$  are respectively the low and upper limit of the AC bus voltage amplitude, phase angle, injected reactive flow;  $U_{d\min}$ ,  $U_{d\max}$  are the limits of the  $U_d$ ;  $P_{dN}$  is the capacity of the VSC;  $P_{DG}$  is the power output of DG and  $P_{DG\max}$  is the maximum output flow.

### 2.3. Power Flow Calculation of AC/DC Distribution System with VSC-MTDC

#### 2.3.1. Structure of AC/DC Distribution System with VSC-MTDC

The conventional radial AC distribution network commonly contains a single power source, which supplies power for loads through feeders. Several AC sub-systems will be formed when an AC distribution network transforms into an AC/DC hybrid distribution system. In order to analyze this hybrid system conveniently, the AC system connected directly with the transmission network is defined as the first AC system, while others are branch AC systems. AC systems are interconnected through VSC-MTDC system without direct connection, *i.e.*, loop network is not taken into consideration. Power for the first AC system is supplied by the transmission network, while power for other branch AC systems is supplied by the DC system or distribution energy resources (DERs). The AC/DC distribution system still transfers electricity through the radial distribution network. The construction of VSC-MTDC AC/DC distribution system is presented in Figure 2. AC system 1 connects with the transmission network and operates as the first AC system, while AC system 2,3, ... , N are branch AC systems. The first AC system can connect with one or more DC systems. DERs are connected with DC system or AC systems.

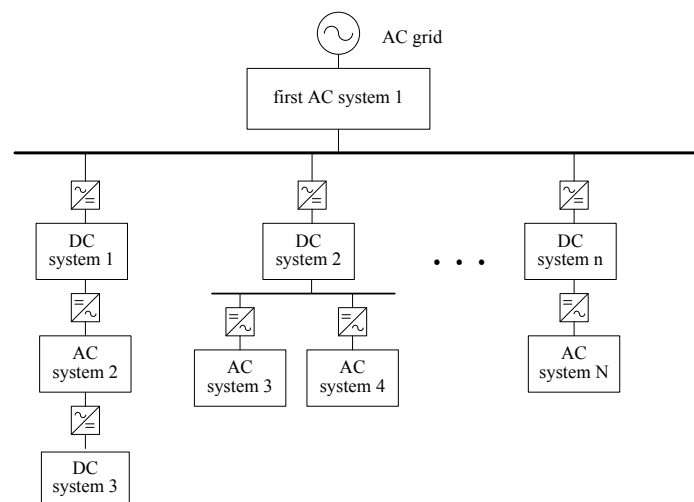

**Figure 2.** Structure of AC/DC distribution network with VSC-MTDC.

In the power flow calculation of AC systems, the corresponding AC nodes are considered as load nodes when the control mode of the inverter connected with the DC system is constant active power as

modes 1 and 2 or constant DC voltage as modes 3 and 4. Furthermore, the corresponding AC nodes are considered as the balance node of this AC system when the control mode is constant AC voltage (amplitude and phase) as mode 5. Therefore, there is only one converter to be controlled by a constant AC voltage pattern in order to ensure the uniqueness of the balance node. The node connected with the transmission network is selected as the balance node. In the DC power flow calculation, an inverter with constant DC voltage control mode is needed to balance the power conversion.

2.3.2. The Interface Equation of AC/DC Power Flow Alternate Calculation

2.3.2.1. Operation with Constant Active or Reactive Power

The equivalent injection power  $P_s$  and  $Q_s$  of AC system is constant, and AC voltage  $\dot{U}_s$  can be obtained by power flow calculation of AC system. In AC network, those nodes are assumed as PQ nodes. DC power  $P_d$ , DC voltage  $U_d$ , phase shift angle  $\delta$  and modulation depth  $M$  are unknown and needed to be calculated.

Converter station connects with AC system on one side, and its equivalent power flow model is presented in Figure 3.

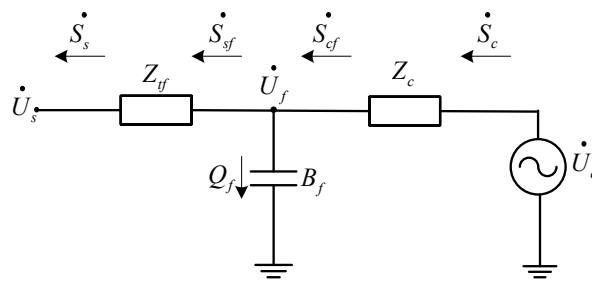

**Figure 3.** Equivalent single phase power flow model of a converter station connected to the AC grid.

$P_s, Q_s$  are known, and  $\dot{S}_s = P_s + jQ_s, \dot{U}_c, P_c, Q_c$  can be calculated by Equations (15)–(20), and then phase shift angle  $\delta$  can be obtained.

$$\dot{I}_{if} = \dot{S}_s^* / \dot{U}_s^* \tag{15}$$

$$\dot{U}_f = \dot{U}_s + \dot{I}_{if} \times Z_{tf} \tag{16}$$

$$\dot{S}_{cf} = \dot{U}_f \times \dot{I}_{if}^* + j(-B_f \times U_f^2) \tag{17}$$

$$\dot{I}_c = \dot{S}_{cf}^* / \dot{U}_f^* \tag{18}$$

$$\dot{U}_c = \dot{U}_f + \dot{I}_c \times Z_c \tag{19}$$

$$\dot{S}_c = \dot{U}_c \times \dot{I}_c^* \tag{20}$$

Then,  $P_{loss}$  and  $P_d$  can be calculated by Equations (6) and (5), respectively.  $U_d$  can be obtained by solving the equation of DC network, and modulation depth  $M$  is calculated by Equation (7).

### 2.3.2.2. Operation with Constant Active Power and AC Voltage Amplitude

When constant active power and AC voltage control mode is applied to the inverter, the equivalent injected reactive power  $Q_s$  and AC voltage phase angle  $\theta_s$  of AC system can be obtained by solving power flow calculation. In AC network, those nodes are assumed as PV nodes. DC power  $P_d$ , DC voltage  $U_d$ , phase shift angle  $\delta$  and modulation depth  $M$  are unknown and the calculation process is the same as in Section 2.3.2.1.

### 2.3.2.3. Operation with Constant AC Voltage

When constant AC voltage control mode is applied to the inverter, the equivalent injected power  $P_s$ ,  $Q_s$  of AC system can be obtained by solving power flow calculation of AC network. In AC network, this node is assumed as the balance node. AC voltage  $\dot{U}_s$  is known. DC power  $P_d$ , and DC voltage  $U_d$ , phase shift angle  $\delta$  and modulation depth  $M$  are unknown and the calculation process is the same as that in Section 2.3.2.1.

### 2.3.2.4. Operation with Constant DC Voltage and Reactive Power

When constant DC voltage and reactive power control mode is applied to the inverter, DC and AC voltage amplitude, equivalent injected reactive power are known, while equivalent injected active power, phase shift angle and modulation are unknown.

In order to obtain  $P_s$ , the relevant DC active power  $P_{db}$  needs to be calculated by solving DC network equations firstly. Due to the known DC node voltage  $U_{db}$  of the inverter operated with constant DC voltage control mode,  $n_c-1$  modified equations exists, that is

$$\left[ P_{di}^{ref} - P_{di} \right] = J_d' \left[ \Delta U_{di} \right] \quad (21)$$

$$P_{di} = U_{di} \sum_{j=1}^{n_c} Y_{ij} U_{dj} \quad (22)$$

$$J_d' = J_{d(i \neq b, j \neq b)} \quad (23)$$

where,  $i = 1, 2, \dots, n_c, i \neq b$ ,  $b$  represents the inverter operated with constant DC voltage control mode, and  $n_c$  stands for the number of inverters.  $J_d'$  is the  $(n_c - 1) \times (n_c - 1)$  Jacobian matrix of modified equations.  $J_d$  is the  $n_c \times n_c$  Jacobian matrix of DC network and can be calculated as per Equation (24).  $P_{di}^{ref}$  is the reference value of DC active power of inverters operated with non-constant DC voltage control mode.  $P_{di}$  is the DC active power of corresponding networks, and  $Y_{ij}$  is the conductance matrix element of the DC network.

$$J_{dij} = \begin{cases} 2Y_{ii}U_{di} + \sum_{\substack{m=1 \\ m \neq i}}^{n_c} Y_{im}U_{dm} & i = j \\ Y_{ij}U_{di} & i \neq j \end{cases} \quad (24)$$

To acquire unbalance magnitude of DC voltage, solve the modified equations. Then, modify the DC voltage until the iteration result satisfies convergence criteria.  $P_{db}(i = b)$  can be calculated by Equation (22) and then  $P_s$  can be obtained.

In the initial calculation, the loss of inverters is unknown. The assumed initial value of equivalent injected active power is shown as Equation (25). Equivalent injected active power from the last iteration is applied to this iteration.

$$\begin{cases} P_{sb}^0 = - \sum_{i=1, i \neq b}^{n_c} P_{si}^{ref} \\ P_{si}^0 = P_{si}^{ref} \quad i = 1, 2, \dots, n_c, i \neq b \end{cases} \quad (25)$$

where, superscript 0 represents initial value, and  $P_{si}^{ref}$  is the AC active power reference value of inverter  $i$ .

The loss of inverters is obtained according to Equations (15)–(18) and (6) and then  $P_c$  can be found from Equation (26).

$$P_c = P_d - P_{loss} \quad (26)$$

Set  $P_c, Q_s$  as the reference values  $P_c^{ref}, Q_s^{ref}$  for calculation, respectively. The unbalanced modified equations are shown as:

$$\begin{bmatrix} P_c^{ref} - P_c \\ Q_s^{ref} - Q_s \\ -F_1 \\ -F_2 \end{bmatrix} = J \begin{bmatrix} \Delta\theta_c \\ \Delta\theta_f \\ \Delta U_c \\ \Delta U_f \end{bmatrix} \quad (27)$$

where,  $J$  is the Jacobian matrix, and  $F_1, F_2$  are shown as:

$$F_1 = P_{cf} - P_{sf} \quad (28)$$

$$F_2 = Q_{cf} - Q_{sf} - Q_f \quad (29)$$

$$P_{sf} = U_f^2 G_{ff} - U_s U_f [G_{ff} \cos(\theta_s - \theta_f) - B_{ff} \sin(\theta_s - \theta_f)] \quad (30)$$

$$Q_{sf} = -U_f^2 B_{ff} + U_s U_f [G_{ff} \sin(\theta_s - \theta_f) + B_{ff} \cos(\theta_s - \theta_f)] \quad (31)$$

$$P_{cf} = -U_f^2 G_c + U_c U_f [G_c \cos(\theta_f - \theta_c) + B_c \sin(\theta_f - \theta_c)] \quad (32)$$

$$Q_{cf} = U_f^2 B_c + U_c U_f [G_c \sin(\theta_f - \theta_c) - B_c \cos(\theta_f - \theta_c)] \quad (33)$$

Unbalanced values can be obtained by Equations (1)–(4) and (28)–(33). Modified values can be obtained by solving relevant equations with Jacobian matrix to calculate  $\Delta U_c$ , and  $Q_c$  can be obtained by Equation (4). Then, recalculate the loss of inverters and obtain  $P_c$  by Equation (26) to compare with  $P_c^{ref}$ . If the iteration satisfies the criteria, end the calculation; otherwise set  $P_c$  as the new  $P_c^{ref}$  to resolve the modified equations until iteration converges. Then, equivalent injected active power  $P_s$ , phase shift angle  $\delta$ , modulation  $M$  can be obtained.

### 2.3.2.5. Operation with Constant DC and AC Voltage

When the inverter control mode operates with constant DC and AC voltage pattern, DC and AC voltage magnitudes are known and equivalent injected active and reactive power, phase shift angle and modulation are unknown.

The solution is the same as Section 2.3.2.4. The initial value of  $Q_s^{ref}$  can be set as  $0.5P_s$ .  $Q_s$  is obtained by Equation (2) after solving modified equations. Convergence of  $Q_s$  to  $Q_s^{ref}$  needs to be



evaluated:  $Q_s^{ref}$  should be updated for the next iteration if divergent, otherwise  $P_s$ ,  $Q_s$ ,  $\delta$  and  $M$  can be obtained.

### 2.3.3. Alternation Algorithm of AC/DC Distribution System Incorporating VSC-MTDC

Alternation algorithm can be applied to the solution with the AC flow interface equations mentioned above. However, the traditional alternation algorithm does not work on the VSC-MTDC AC/DC distribution system. Thus, a back/forward iterative algorithm is proposed for the power flow calculation of the AC/DC distribution system in this paper by improving the traditional algorithm.

Although loops exist in traditional distribution networks, they are assumed to be opened to be radial after the incorporation of DC distribution network, *i.e.*, AC distribution system is divided into several AC sub-systems. The solutions for them are different according to whether it is an active network or not. As a result, it is unable to solve all calculations with the same method. Thus, a back/forward iterative method started from the end of the radial network is proposed. In one iteration, there are several power flow alternative calculations of the AC/DC system. Hence, an improved back/forward iterative algorithm is proposed. In the calculations of AC systems, if it is an active AC network with several sources, Newton method is used instead of back/forward iterative method. If it is a passive AC network, back/forward iterative method is applied.

In the algorithm,  $P_{sb}$  is modified by the results of DC power flow. In the calculation of AC networks, if the reactive power of a PV node is out of limit, this node is converted into a PQ node. If the voltage amplitude of a PQ node is out of limit, this node is converted into a PV node. In the calculation of DC network, if DC voltage of any VSC is out of limit, this voltage will be set as the new voltage limit and then the power flow calculation should be repeated. If the error between  $\Psi$  and the last iteration result is satisfactorily small, the problem is convergent. Therefore, iteration convergence criterion is

$$\max |P_{si}^{(k)} - P_{si}^{(k-1)}| < \varepsilon \quad (34)$$

where, superscript  $k$  represents  $k$ th iteration.

Back/forward iterative algorithm of AC/DC distribution system is separated into the following steps:

- Step 1: Input the data of AC/DC network power flow calculation and characteristic, set  $k = 1$ , then forward sweep from end of the network.
- Step 2: Determine the characteristic of networks. If it is a branch AC and passive network, apply back/forward iterative algorithm to power flow calculation until convergence, and apply Newton method if it is a branch AC and active network. When  $P_{si}^{(k)}$  and  $Q_{si}^{(k)}$  of VSC are acquired, go to step 4, otherwise continue with step 3.
- Step 3: Determine the characteristic of networks. If it is a DC network, calculate  $P_{di}^{(k)}$  of the inverters operated with non-constant DC voltage pattern at first, then solve DC network to obtain the DC voltage and active power of other inverters. Turn to step 4 after obtaining  $P_{sb}^{(k)}$ ,  $\delta_i^{(k)}$  and  $M_i^{(k)}$ , otherwise move to step 5.
- Step 4: Continue to determine the characteristic of a next network. If it is a branch AC network, return to step 2. If it is a DC network, return to step 3. If it is the first AC network, go to step 5.
- Step 5: Determine the characteristic of networks. If it is the first AC network, apply Newton method to obtain  $P_{sb}^{(k)}$ . Until this step, an iteration of this algorithm for the AC/DC distribution system

has been finished. If the result is convergent, the calculation is complete, otherwise  $k = k + 1$ , and return to step 2 with the DC system data acquired by the steps above.

### 3. Modeled Case

The modified IEEE14 bus AC/DC distribution system shown in Figure 4 is used to verify the effectiveness of the proposed algorithm. The voltage base value is 23 kV and the power base value is 100 MVA. The IEEE14 bus AC/DC distribution system consists of two DC networks, four AC networks (one first AC network and three branch AC networks) and five VSC inverters whose high-voltage sides are connected with AC bus 3, 5, 2, 7 and 11, respectively.

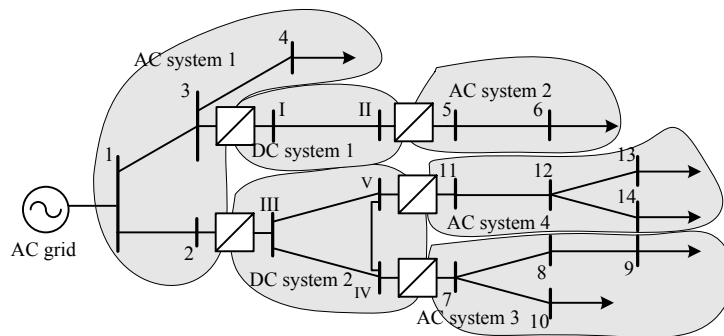

**Figure 4.** Modified IEEE14 bus AC/DC distribution system based on VSC-MTDC.

The data of voltage and power is shown in per unit (p.u.). The parameters of inverters are the same. Impedance of converter transformer is  $0.0015 + j0.1121$  p.u., usage ratio  $\mu$  of converter transformer DC voltage is  $\sqrt{6}/4$ , filter susceptance is  $j0.045$  p.u., reactor impedance is  $0.0001 + j0.1643$  p.u. AC bus 1 is the balance bus of the first AC network, and the AC amplitude is 1.06 p.u. AC bus 5, 7 and 11 are balance buses of branch AC network 2, 3, 4, and their voltage amplitudes are 1.04, 1.03 and 1.02 p.u., respectively. Voltage amplitudes of the rest PQ buses are 1 p.u., angles are  $0^\circ$ .

Distributed generations (DGs) are connected at different buses in the IEEE14 bus AC/DC distribution system. Then three schemes are proposed and shown in Table 1. VSC control data of DC network is shown in Table 2, control modes are mentioned in 1.2. Control pattern 5 is constant AC voltage mode, and control pattern 3 is constant DC voltage and reactive power mode.

The power flow calculation result of the AC system is shown in Table 3, while the DC system result is shown in Table 4.

All the schemes converge after three iterations. Additionally, the results meet the control requirement of each VSC. For Scheme 1 in Table 4, voltage phase angle of VSC II, VSC III lags behind the corresponding AC bus voltage phase angle, so VSC absorbs active power from AC network. Voltage phase angle of VSC I, VSC IV, VSC V leads ahead of the AC-side voltage phase angle, so VSC injects active power to AC network. The result is same as the calculation value of  $P_s$ . For scheme 2, voltage phase angle of VSC I, VSC III lags behind the corresponding AC bus voltage phase angle, so VSC absorbs active power from AC network. Voltage phase angle of VSC II, VSC IV, VSC V leads ahead of the AC side voltage phase angle, so VSC injects active power to AC network. The result is the same as the calculation value of  $P_s$ . For Scheme 3, voltage phase angle of VSC III lags behind AC bus voltage phase angle, so VSC absorbs active power from the AC network. Other VSC voltage phase angle leads

ahead, so VSC injects active power to AC network. It is indicated that DGs can supply active power to AC network through DC network, and achieve bidirectional power flow.

**Table 1.** Summary of Schemes.

Scheme		Photovoltaic Power Generation	Wind Power Generation	Fuel Cells	Gas Turbine Power Generation
Scheme 1	Bus	AC 3	AC 5	AC 8	AC 12
	Flow	0.04	0.02	0.03	0.02
Scheme 2	Bus	AC 3	AC 8	DC II	DC IV
	Flow	0.04	0.02	0.03	0.02
Scheme 3	Bus	DC I	DC II	DC IV	DC V
	Flow	0.04	0.02	0.03	0.02

**Table 2.** Control parameters of VSC.

VSC	I	II	III	IV	V
Control pattern	3	5	3	5	5
$U_d$	2.004	2.000	2.006	2.000	2.000
$P_s$	0.000	0.000	0.000	0.000	0.000
$Q_s$	-0.022	0.000	-0.022	0.000	0.000

**Table 3.** Results of power flows of AC system.

Bus	Scheme 1		Scheme 2		Scheme 3	
	Voltage Amplitude	Voltage Phase	Voltage Amplitude	Voltage Phase	Voltage Amplitude	Voltage Phase
1	1.0600	0.0000	1.0600	0.0000	1.0600	0.0000
2	1.0386	-1.1888	1.0393	-1.1383	1.0385	-1.1948
3	1.0567	0.2496	1.0556	0.1930	1.0567	0.2493
4	1.0550	0.2203	1.0540	0.1636	1.0550	0.2200
5	1.0400	0.0000	1.0400	0.0000	1.0400	0.0000
6	1.0392	-0.0424	1.0392	-0.0424	1.0392	-0.0424
7	1.0200	0.0000	1.0200	0.0000	1.0200	0.0000
8	1.0160	0.0497	1.0169	0.1491	1.0133	-0.2495
9	1.0149	0.0430	1.0158	0.1424	1.0123	-0.2562
10	1.0160	-0.1161	1.0160	-0.1161	1.0160	-0.1161
11	1.0400	0.0000	1.0400	0.0000	1.0400	0.0000
12	1.0228	-0.5417	1.0212	-0.6613	1.0212	-0.6613
13	1.0158	-0.6934	1.0142	-0.8134	1.0142	-0.8134
14	1.0170	-0.8612	1.0154	-0.9818	1.0155	-0.9818

**Table 4.** Results of power flows of DC system.

VSC		I	II	III	IV	V
Scheme 1	$U_d$	2.0040	2.0041	2.0060	2.0044	2.0040
	$I_d$	0.0039	-0.0039	-0.1181	0.0281	0.0900
	$\delta / ^\circ$	0.0932	-0.1324	-3.5780	0.8273	2.5423
	$M$	0.8500	0.8433	0.8358	0.8363	0.8604
	$P_s$	0.0064	-0.0090	-0.2417	0.0551	0.1772
	$Q_s$	-0.0220	0.0100	-0.0220	0.0512	0.0840
Scheme 2	$U_d$	2.0040	2.0040	2.0060	2.0046	2.0040
	$I_d$	-0.0011	0.0011	-0.1135	0.0131	0.1003
	$\delta / ^\circ$	-0.0561	0.4543	-3.4322	0.6765	2.8354
	$M$	0.8492	0.8434	0.8363	0.8361	0.8608
	$P_s$	-0.0037	0.0310	-0.2321	0.0451	0.1977
	$Q_s$	-0.0220	0.0100	-0.0220	0.0512	0.0846
Scheme 3	$U_d$	2.0040	2.0041	2.0060	2.0044	2.0040
	$I_d$	0.0039	-0.0039	-0.1187	0.0283	0.0904
	$\delta / ^\circ$	0.3787	0.4543	-3.5953	1.2810	2.8354
	$M$	0.8501	0.8434	0.8358	0.8365	0.8607
	$P_s$	0.0263	0.0310	-0.2428	0.0852	0.1977
	$Q_s$	-0.0220	0.0100	-0.0220	0.0514	0.0846

In Table 5, the absorption power from the AC/DC distribution system and network loss are not identical according to the comparison of the three schemes if the DGs are connected at different buses in the AC/DC distribution network. It is obvious that DC network loss is larger than AC network loss because the inverter loss cannot be neglected, which validates considering inverter loss in this paper. All DGs are connected with AC network in Scheme 1 while all of them are connected with the DC network in Scheme 3. It is shown in Table 5 that the absorbed power and active power loss are minimal in Scheme 1 while maximal in Scheme 3. This occurs because the potential DC/AC conversion, *i.e.*, loss of inverters when DGs connect into AC network, is not taken into consideration.

**Table 5.** Comparison of the absorbed power and losses in the AC/DC distribution network.

Scheme	Scheme 1	Scheme 2	Scheme 3
$S_{in}$	0.2499 + j0.0751	0.2502 + j0.0747	0.2512 + j0.0752
$S_{acloss}$	0.0070 + j0.0093	0.0071 + j0.0095	0.0076 + j0.0102
$P_{convloss}$	0.0115	0.0116	0.0121
$S_{tranloss}$	0.0001 + j0.0108	0.0001 + j0.0111	0.0002 + j0.0123
$S_{reacloss}$	0.0000 + j0.0160	0.0000 + j0.0164	0.0000 + j0.0181
$P_{dcloss}$	0.0002	0.0002	0.0002
$S_{dcloss}$	0.0118 + j0.0268	0.0119 + j0.0275	0.0125 + j0.0304

Note:  $S_{in}$ ,  $S_{acloss}$ ,  $P_{convloss}$ ,  $S_{tranloss}$ ,  $S_{reacloss}$ ,  $P_{dcloss}$ ,  $S_{dcloss}$  represent power absorbed from transmission network, loss of AC network, inverter loss, converter transformer loss, reactor loss, DC line loss and loss of AC network.

As shown in Table 6, the loss of network increases significantly due to the growing converter loss of DGs in Scheme 1 if the converter loss is taken into account. In addition, the loss of network decreases in Scheme 3 because of the reduced convert loss caused by fewer converters if the DGs are connected to the

DC network directly. It is indicated that more converters lead to higher loss if DGs which generate AC power are connected to the AC network instead of the DC network. Besides, the loss of network increases if DGs which generate DC power are connected to the AC network by converters. Hence, it is important to place the DGs properly to reduce the power consumption and losses in the DC/AC distribution network.

**Table 6.** Comparison of the absorbed power and losses considering converter losses of distribution generation.

Scheme	Scheme 1	Scheme 2	Scheme 3
$S_{in}$	$0.2546 + j0.0860$	$0.2541 + j0.0829$	$0.2535 + j0.0778$
$S_{acloss}$	$0.0082 + j0.0112$	$0.0080 + j0.0107$	$0.0079 + j0.0105$
$S_{dcloss}$	$0.0153 + j0.0358$	$0.0149 + j0.0345$	$0.0145 + j0.0327$

Note:  $S_{dcloss}$  is the DC loss of inverter in network including DGs.

The comparison of the absorbed power and losses with different power generation at the same location (same location in Scheme 3) in the DC/AC distribution network is shown in Figure 5. With increasing output of DGs, AC active power loss and the absorbed power both decrease. It is shown that proper DG allocation can help to reduce losses and the absorbed power from transmission networks.

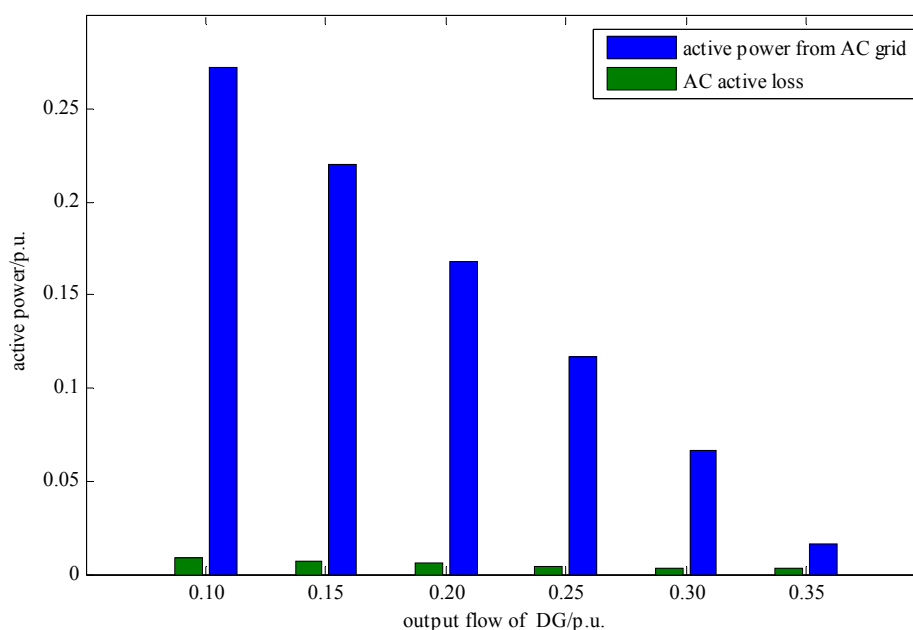

**Figure 5.** Comparison of the absorbed power and losses with different power generation.

These cases indicate that converter loss cannot be neglected. It is beneficial to minimize losses and absorbed power for the optimal power flow of AC/DC distribution systems by properly allocating DG ratings at the right locations.

#### 4. Conclusions

Based on the VSC-HVDC steady-state model, this paper introduces the interface equations under different control modes with consideration of the losses from converter transformers, reactors, filters and

inverters. Further, a back/forward iterative method for the AC/DC distribution system incorporating VSC-MTDC is proposed. At last, the effectiveness of the back/forward iterative method is verified with a modified IEEE14 bus AC/DC distribution system. The algorithm achieves bi-direction power flow calculation and converges to control objection of inverters. Incorporating DGs into AC/DC distribution systems can reduce network losses and absorption of power to optimize the power flow of the AC/DC system.

### Acknowledgments

The authors would like to acknowledge the financial support from the Fundamental Research Funds for the Central Universities of China (No. 12MS107).

### Author Contributions

The author Xiaoling Zhao carried out the main research tasks and wrote the full manuscript, and the author Haifeng Liang proposed the original idea, analyzed and double-checked the results and the whole manuscript. The authors Jin Yang and Xiaolei Yu contributed to the writing and summarizing proposed ideas, and the author Yajing Gao provided financial support.

### Conflicts of Interest

The authors declare no conflict of interest.

### References

1. Wang, D.; Mao, C.; Lu, J. Technical analysis and design concept of DC distribution system. *Autom. Electr. Power Syst.* **2013**, *37*, 82–88. (In Chinese)
2. Hammerstrom, D.J. AC versus DC distribution systems—did we get it right. In Proceedings of the IEEE Power & Engineering Society General Meeting, Tampa, FL, USA, 24–28 June 2007; pp. 1–5.
3. Patterson, B.T. DC, come home: DC microgrids and the birth of the “Enernet”. *IEEE Power Energ. Mag.* **2012**, *10*, 60–69.
4. Nilsson, D.; Sannino, A. Efficiency analysis of low-and-medium-voltage DC distribution systems. In Proceedings of the IEEE Power & Engineering Society General Meeting, Denver, CO, USA, 10 June 2004; pp. 1–7.
5. Mariethoz, S.; Fuchs, A.; Morari, M. A VSC-HVDC Decentralized Model Predictive Control Scheme for Fast Power Tracking. *IEEE Trans. Power Delivery* **2014**, *29*, 462–470.
6. Tang, G. *MTDC Technology Based on Voltage Source Converter*; China Electric Power Press: Beijing, China, 2009; pp. 34–50. (In Chinese)
7. Weimers, L. MTDC Light: A new technology for a better environment. *IEEE Power Eng. Rev.* **1998**, *18*, 19–20.
8. Hertem, V.; Ghandhari, M. Multi-terminal VSC HVDC for the European super grid: Obstacles. *Renew. Sustainable Energy Rev.* **2010**, *14*, 3156–3163.
9. Wang, C.; Wang, S. Study on problems of distributed generation energy supply systems. *Autom. Electr. Power Syst.* **2008**, *32*, 1–4. (In Chinese)

10. Dastgeer, F.; Kalam, A. Efficiency comparison of DC and AC distribution systems for distributed generation. In Proceedings of the Australasian University Power Engineering Conference, Adelaide, SA, Australia, 27–30 September 2009; pp. 1–5.
11. Zhu, K.; Jiang, D.; Hu, P. Study on a new type of DC distribution network containing electric vehicle charge station. *Power Syst. Technol.* **2012**, *36*, 35–41. (In Chinese)
12. Ma, J.; Jiang, Q.; Yu, P. Survey on energy optimized control technology in DC distribution network. *Autom. Electr. Power Syst.* **2013**, *37*, 89–96. (In Chinese)
13. Song, Q.; Zhao, B.; Liu, W. An overview of research on smart DC distribution power network. *Proc. CSEE* **2013**, *33*, 9–19. (In Chinese)
14. Mousavizadeh, S.; Haghifam, M.R. Load flow calculations in AC/DC distribution network including weakly mesh, distributed generation and energy storage units. In Proceedings of the Electricity Distribution 22nd International Conference on Electricity Distribution, Stockholm, Sweden, 10–13 June 2013; pp. 1–4.
15. El-Marsafawy, M.; Mathur, R. A new, fast technique for load-flow solution of integrated multi-terminal DC/AC system. *IEEE Trans. Power Appar. Syst.* **1980**, *99*, 246–255.
16. Beerten, J.; Coles, B.R. Implementation aspects of a sequential AC/DC power flow computation algorithm for multi-terminal VSC HVDC systems. In Proceedings of the IET 9th International Conference on AC and DC Power Transmission, London, UK, 19–21 October 2010; pp. 1–6.
17. Zheng, C.; Zhou, X.; Li, R. Study on the steady characteristic and algorithm of power flow for VSC-HVDC. *Proc. CSEE*. **2005**, *25*, 1–5. (In Chinese)
18. Zhen, C.; Sheng, C. Uniform iterative power flow algorithm for systems equipped with VSC-HVDCs. *Electr. Power* **2007**, *40*, 65–69. (In Chinese)
19. Li, G.; Zhou, M.; He, J. Power flow calculation of power systems incorporating VSC-HVDC. In Proceedings of the International Conference Power System Technology, Singapore, 21–24 November 2004; pp. 1562–1566.
20. Chen, Q.; Tang, G.; Wang, X. AC-DC power flow algorithm for multi-terminal VSC-HVDC systems. *Autom. Electr. Power Syst.* **2005**, *25*, 1–6. (In Chinese)
21. Sun, G.; Li, Y.; Wei, Z. State estimation of power system with VSC-HVDC. *Electr. Power Autom. Equip.* **2010**, *30*, 6–12. (In Chinese)
22. Chai, R.; Zhang, B.; Bo, Z. Alternating Iterative Power Flow Algorithm for Hybrid AC/DC Networks Containing DC Grid Based on Voltage Source Converter. *Autom. Electr. Power Syst.* **2015**, *39*, 7–13. (In Chinese)
23. Beerten, J.; Cole, S.; Belmans, R. Generalized steady-state VSC MTDC model for sequential AC/DC power flow algorithms. *IEEE Trans. Power Syst.* **2012**, *27*, 821–829.
24. Zhang, X. Multiterminal Voltage-Sourced Converter-Based HVDC Models for Power Flow Analysis. *IEEE Trans. Power Syst.* **2004**, *19*, 1877–1884.
25. Han, B.M.; Karady, G.G.; Park, J.K. Interaction analysis model for transmission static compensator with EMTP. *IEEE Trans. Power Delivery* **1998**, *13*, 1297–1302.