

KHAZAR UNIVERSITY

Faculty: Engineering and Applied Sciences

Department: Computer Engineering

Specialty: Computer systems and networks Software

MASTER THESIS

Theme: Automated indoor climate control system

Master Student: Aynur Ahmadova

Supervisor: Ph.D. Nuru Arab Safarov

BAKU – 2017

1. Terms of Reference.....	6
1.1 General information	6
1.2 Purpose of the ACS.....	6
1.3 General characteristics of the control object	7
1.4 System Requirement.....	8
1.5 Composition and content of the work on the creation of the ACS	25
1.6 Requirements for the composition and content of work on the preparation of an automation object for the commissioning of the system.....	25
1.7 Documentation requirements	27
1.8 Sources of development.....	28
2. Description of the object of automation and the algorithm of its functioning	29
3. Analysis of the system requirements.....	31
3.1 System Structure Requirements.....	32
3.2. System operation requirements.....	34
4. Review of existing decisions and justification of the choice of the accepted principle of construction of the projected system.....	35
4.1 General.....	35
4.2 Water supply	36
4.3 Heating and ventilation	38
4.4 Electrical devices.....	39
5. Description of the developed solution of the control system ensuring the fulfillment of the requirements of the technical task	40
5.1 Equipping a green house	40
5.2 Greenhouse equipment.....	40
5.3 Central Operator Station	41
6. Description of collateral types	42
6.1 Software	42
6.2 Information support	Error! Bookmark not defined.3
7. Development of a database of control and regulation parameters	45
8. Description of the scheme of functional electrical automation	46
9. Selection and justification of individual units and elements	47
9.1. The humidity sensor	47
9.2 Spray water flow sensor	47

9.3. The executive mechanism.....	52
9.4 The water level sensor in the ADZ-Floater Probe SML-PS1 "NAGANO" tank	53
9.5 Moisture Sensor Gardena	54
9.6 Room temperature sensor for the greenhouse KTY81-210.....	54
9.7 Tank temperature sensor in the reservoir numerix ETF01	54
9.8 Industrial controller Modicon 984 – 685	54
9.9 Console Pump K 200-150-250 / 4-5	57
10. Selection and description of the control loop	59
11. Calculation of the adjustment parameters of the control loop	61
11.1 Calculation of the parameters of the circuit nodes.....	66
12. Development of workstation	68
13. Arduino	71

ABSTRACT

Every year in greenhouse enterprises, more and more attention is paid to the quality maintenance of the microclimate. Correctly chosen technology of microclimate maintenance is one of the most important components that allow increasing yield. And effective use of energy resources is an additional opportunity to significantly reduce the cost of production. The modern automated microclimate control system should support not only the preset mode, but also maximize the use of the capabilities of the executive systems.

At the present time, active modernization of greenhouses is being carried out, connected with the increase in the number of executive systems: separation of contours, modernization of ventilation, installation of shading systems, installation of fans. And the more executive systems the greenhouse has, the more important it is for it to choose the criterion that determines the strategy for maintaining the microclimate. For example, one of the most popular management criteria is the saving of heat resources. In this case, it is more appropriate to actively use the lower heating circuits, because they give away heat to the external environment least of all. Another approach to the selection of the criterion involves maintaining the temperature at the growth point higher than at the roots of the plant and thus implies the active use of upper heating circuits. Another criterion of management is based on the fact that the lower contour should maintain a constant temperature in the root zone, the so-called optimum, and only with exhausted resources of other executive systems deviate from it.

Experience in the implementation of automated control systems shows that at the design stage of the system it is difficult to select a single management criterion. Therefore, the control system should be able to promptly set the criterion during operation, and the methods of its assignment should visually reflect the agronomic, economic and technical requirements imposed on the system. Thus, the modern management system should allow us to specify not only one of the above control criteria or a combination thereof, but also any other arising in the production process, giving the agronomist technologist ample opportunities in choosing the method for maintaining the temperature and humidity regime in the greenhouse

One of the main characteristics of the control system is its reliability. Therefore, as a hardware-technical base of the system, a controller was selected which contains modern means of protection from failures: a copy of the main parameters of the system operation in nonvolatile memory, a means of protection against freezes, etc. In addition to the controller, the automated climate control system includes a set of sensors for measuring parameters inside the greenhouse. To transfer control actions to actuators, the system includes a relay switching unit with the possibility of manual control.

An important element of the control system is the diagnosis of faults and the capabilities of the control system. Sometimes unforeseen situations occur in the course of operation due to instability in the temperature of the supplied water, increased wear and play of the actuator, or other limitations imposed on the actuating systems. The diagnostic methods embedded in the system should identify non-standard situations and timely adjust the control algorithms, while maintaining the microclimate parameters with the minimum possible deviation. If it is impossible to resolve the situation without human intervention, the system issues an appropriate alarm message.

1. Terms of Reference

1.1 General Information

The present terms of reference are developed in accordance with GOST 34.602-89 "Information technology." Technical task for the creation of an automated system."

Name of the system

Automated system of climate control and management in farms. Conventional designation - ASU CTC.

The order of control and reception

The completed course project is signed by the executor, verified and signed by the head and submitted to the protection in the prescribed manner.

Changes and additions

This TOR can be clarified in the process of developing and designing the process control system by issuing supplements approved in accordance with the established procedure.

1.2 Purpose of the ACS

Purpose of the ACS of the CTCT

ACS CCTV is designed to perform a complex of information and control functions that ensure:

- setting a daily cycle of humidity and maintaining the necessary climate regime (when the task is changed, the system ensures a smooth transition from one state to another);
- control of water flow in the spray channel;
- collection, processing and storage of archival data;
- presentation of technological information in a form convenient for operating personnel;

- Event recording and logging of alarms (for example, when the humidity value falls outside the specified range);
- providing the possibility of calibration of measuring sensors;
- Increase of productivity of a hothouse due to rigid automatic maintenance of required parameters;
- Ensuring the possibility of gradual modernization and complication of the system due to the introduction of new hardware and software modules.

The objectives of the ACS SCC

The objectives of the ACS of the CTC are:

- Implementation of a highly efficient, modern automated control system that ensures the maintenance of the necessary climate regime through the use of optimal PID control loops;
- Ensuring the smoothness of the transition from one state to another if the climatic conditions deviate from the norm or when such necessity arises;
- Ensuring the reliability and adequacy of information on the technological process and the state of technological equipment;
- Reduction of costs for maintenance and repair;
- Ensuring high reliability and maintainability of control and protection systems;
- Operative reporting on the economic performance of the water intake unit;
- Accumulation of information about the technological process and the operation of process equipment.

1.3 General characteristics of the control object

Brief information about the automation object

The project of management and control of climate in greenhouses is typical. In a room of 80 to 60 meters with good thermal insulation, flowers are grown that require some constant climatic conditions or a smooth change in them. Temperature, humidity and CO level are measured by sensors and by means of a PID loop, corrective control actions are calculated and formed, which are realized by means of a heating system, an air conditioner, a gas supply system CO. The room also contains the operator control panel and information collection systems. If the values of the climatic conditions deviate from the norm, control actions are automatically accepted.

When the normal conditions change with the help of the operator panel, control actions are taken, which return the system to normal mode.

The water intake unit includes the following main technological installations and systems:

- Air conditioning;
- Room heating system;
- Monitoring of climatic conditions in the room;
- Power supplies for monitoring and control systems;
- Temperature, humidity, CO level sensors;
- Operator control panel;
- Filter;
- Pump;
- Manager;

Information on the operating conditions of the facility automation and environmental characteristics

With regard to electrical safety, all blocks and compartments of greenhouse block equipment, according to the PUE, belong to explosion-proof rooms with a normal environment of category D.

The operator room and the room for microprocessor controllers also belong to explosion-proof rooms with a normal environment of category D.

1.4 System Requirements

Requirements for the structure of the system

The automated climate control and control system in greenhouse farms should be distributed and implemented on the basis of microprocessor technology.

According to the hierarchical principle of ACS, the QCTC should be divided into levels:

Lower level:

- Measuring transducers of soil parameters;
- Measuring transducers of air environment parameters;
- Measuring transducers of water supply network parameters;
- Regulatory and other enforcement mechanisms;

top level:

Operator station (operator's workplace);

Automated control and climate control of the greenhouse should be carried out from the central control room without the constant presence of operating personnel in the area of the technological equipment.

Communication between the components of the system must be carried out through physical and interface channels.

ACS CCTV must be connected to a guaranteed power supply system using uninterruptible power supplies.

Each operator station must include:

A standard configuration computer:

- RAM 128 MB, a floppy disk drive, a hard disk drive with a capacity of 10-20 GB;
- one color monitor;
- technological keyboard;
- manipulator type "mouse".

The technological keyboard is designed for operational control of the process and should have a set of function keys programmed to the display videograms and allowing uniquely execute the process control commands. The keyboard should be comfortable and easy to use.

Requirements for the functioning of the system

ACS CCTV should:

- to ensure the efficient operation of process equipment without the constant presence of operating personnel in the area of equipment deployment with a minimum number of manual operations and safe working conditions;
- ensure high reliability of automatic regulation and control of the technological process due to the use of modern hardware and software;
- facilitate the work of the maintenance staff by simplifying the procedure for starting up the equipment, maintaining the technological process, switching from one well to another, etc .;

Provide interaction with:

- systems for collecting and processing information - via RS-485 network;
- executive mechanisms and aggregates - through physical communication channels;
- Automatic control system for executive devices - via RS-485 network.

The operator station must be equipped with an emergency stop system for the possibility of correct shutdown of the units in case of failure of communication channels with microprocessor equipment.

Requirements for the number and qualifications of staff

ACS CCTV should be serviced by personnel who have been trained in special training courses and have certificates for the right to work with computer facilities or relevant specialists.

The number and mode of operation of maintenance personnel should be sufficient for maintenance of the ACS of the KKKH and repair work with 24-hour operation of the equipment.

Requirements to Indicators of Purpose

ACS QCTC should allow for the correction of control algorithms in the event of a change in the structure of the object. For this:

- Use programmatic methods of centralized control and management;
 - Provide a reserve for input and output signals at the level - not less than 10%;
 - Provide a margin for the amount of memory RAM at the level - not less than 15%;
 - Provide a margin for the load on the output signals - at the level of 30%;
- Provide free space for expansion of the system - at least 10%.

Reliability requirements

ACS CCTV should be a multi-channel, multifunctional system of long-term use and be a maintainable object with periodic maintenance. Requirements for indicators of reliability of the system are established in accordance with GOST 24.701-84. Requirements for failure-free operation of the ACS CCTV are set for individual functions.

The average operating time of the ACS of the KKKH for failure of the type "Passing the accident" when operating under normal conditions without taking into account the primary converters and actuators should be not less than 100,000 hours. The criterion for failure of the type "Skip Accident" is the event consisting in the absence of a command to control the emergency stop of the engines at the output of the ACS of the KKTH in the presence of any of the alarms on its inputs.

The average operating time of the ACS CCTV for failure type "False emergency stop" when operating under normal conditions without taking into account the primary converters and actuators should be at least 40,000 hours.

The failure criterion of the "False emergency stop" type is the event consisting in the presence of an issued command to control the emergency stop of the motors in the event of an actual absence of an emergency situation at the facility. The average operating time of the ACS CCTS for failure of the type "Failure of control commands" when operating under normal conditions without taking into account the primary converters and actuators should be not less than 40,000 hours.

The failure criterion of the type "Failure to perform control commands" is an event consisting in the absence of the necessary control command in the selected operating mode of the ACS CCTV engines.

The average operating time of the ACS of the KKKH for failure on any of the main channels for monitoring the parameters of temperature, pressure, speed, current consumption, etc., when operating under normal conditions without taking primary transformers into account, should be at least 50,000 hours.

The criterion for the failure of the measuring channel is the impossibility of obtaining reliable information about the parameter.

Confirmation of indicators of failure-free operation of control channels and measuring channels is carried out by control tests at least once every three years.

The monitoring of the longevity of the measuring channel and the control channel is carried out by processing statistical data obtained in the operating conditions using the parametric method of DSTU 3004-85.

The average recovery time of the operable condition of the ACS CCTV by replacing the faulty replacement block, module or device from the spare parts inventory should be no more than 1 hour, including the time of the search for a malfunction. The average lifetime of the ACS CCTV should be at least 10 years. The values of the reliability indicators of the ACS of the RCP should be confirmed as follows:

Calculation of failure-free operation:

at the development stage - in an analytical way with an exponential law of distribution of failure rates;

- in the process of operation - on the basis of observation of its operability at the operation sites;

- calculation of maintainability:

At the development stage - in an analytical way according to the expert assessment of the recovery time;

In the process of operation - on the basis of observation of its maintainability at the operation sites.

Safety requirements

Installation, adjustment, operation, maintenance and repair of the system's technical facilities must be carried out in accordance with the requirements:

- "Rules for the installation of electrical installations" of the sixth edition, 1985;
- "Rules for the technical operation of consumer electrical installations" of the fourth edition, approved on 21.12.84;

"Rules of safe operation of electrical installations of consumers";

- instructions of manufacturers of equipment;
- factory safety instructions.

All current-carrying parts of ASU CCTV technical equipment, which are under voltage, must be protected against accidental contact. Metal cabinets, consoles, cabinets, electrical equipment housings must be grounded. Electrical isolation of galvanically separated circuits of technical means of ACS of the KKKH relative to the hull and with each other at a temperature of $20 \pm 5^\circ\text{C}$ and a relative humidity of up to 80% must withstand within 1 minute the action of the test voltage of the sinusoidal form of the industrial frequency:

- between circuits with voltage up to 40V - 250V;
- between circuits with voltage from 60V to 250V - 1500V.

The electrical resistance of the insulation of electrically unconnected ACS of the ACS relative to the housing and among themselves should be at least $20\text{M}\Omega$ at a temperature of $20 \pm 5^\circ\text{C}$ and a relative humidity of up to 80%. The technical means of the ACS of the KKKH must have an electrical connection for a screw or a terminal for protective earthing, near which a protective grounding mark should be marked.

The resistance between the grounding screw, the terminal and each accessible metallic contact with the non-conductive part of the product, which may be under voltage, must not exceed 0.1 Ohm.

According to the method of protecting a person from electric shock, the technical means of the ACS of the KKKH must comply with class 0I and ensure the requirements for the earthing of devices in accordance with GOST 12.2.007-75.

Explosion-proof, intrinsic safety of measurement circuits of ASU CCTV technical means shall be ensured. Devices having intrinsically safe input circuits or providing intrinsic safety must have appropriate inscriptions and signs, as well as places for sealing, if necessary.

Power conductors must be connected to consumers through protective circuit breakers.

The noise level created by the technical means of the ACS of the SCCT at work should not exceed 75 dB, in the places of permanent location of personnel.

Requirements for ergonomics and technical aesthetics

The methods and forms for presenting information to operational personnel, controls and management bodies should be carried out taking into account engineering psychology and technical aesthetics ensuring the informational, motor and anthropological correspondence of the operator-controlled facility system and conforming to the OST 36.13-90 "Boards and control panels of automation systems Technological processes".

At the same time, the placement of monitoring and control means should correspond to the technological process (sequence of nodes) and allow for active monitoring and control, both in normal mode and in emergency situations.

The workstation of the operator must be a workstation.

The number of controls and display elements should be minimal, but sufficient to perform all the functions assigned to the operator.

All the information necessary to conduct the technological process must be displayed on the screens of the video monitors of the workstation.

The layout of the technical means of the ACS of the KKKH must provide free access to them for adjustment and repair.

Requirements for operation, maintenance, repair and storage of system components

The technical means of the ACS of the KKKH (central part) should be operated around the clock for 365 days a year with specified technical parameters.

Technical means of ACS TP CC (central part) should be designed for operation in closed, non-heated and ventilated rooms.

In terms of environmental protection, the technical means of the ACS of the KKKH (central part) should be of the usual design, with a degree of protection in accordance with GOST 14254 - 80.

In terms of resistance to temperature, humidity and atmospheric pressure, the technical means of the ACS of the CTCT (central part) should be designed for operation under the following conditions:

- ambient air temperature - from -15°C to $+40^{\circ}\text{C}$;
- relative air humidity - from 30% to 80% at a temperature of $+35^{\circ}\text{C}$ and lower temperatures without condensation of moisture;
- atmospheric pressure - from 84kPa to 107kPa.

Power supply ACMU should be provided from the main and backup galvanically isolated electrical systems. As the main power supply, use the AC voltage source of $220\text{V} \pm 10\%$, 50Hz, as a backup - the source of constant voltage $220\text{V} \pm 10\%$. Power supply to ACMU must be supplied through automatic fuses. The technical means of the ACS of the KKKH (central part) should remain operative in the presence of permanent or variable, frequency 50 Hz, magnetic fields with a strength of not more than 40 A / M.

ACS CCTV should allow to conduct the technological process without the constant presence of maintenance personnel in the zone of operation of technological equipment.

The area of premises for the placement of technological and maintenance personnel, as well as for the installation of technical means of the ACS of the KKKH (central part), should be sufficient for the normal operation of personnel and maintenance of equipment.

The technical means of the ACS of the KKKH (central part) should be powered from an alternating current network with parameters of $380\text{V} \pm 10\%$, frequency $50 \pm 1\text{Hz}$ and the content of higher harmonics of the mains supply no more than 5%.

ACS QCTC (central part) should be serviced by personnel who have been trained in special training courses and have certificates for the right to independent work.

The complex of technical means of the ACS of the KKKH (central part) should be equipped with 100%, according to the nomenclature of the applied modules and units, a set of spare parts, the complete set and serviceability of which must be maintained during the entire life of the ACS of the KKKH. Storage conditions SPTAs must meet the requirements of operational documentation for the appropriate technical means.

Types of maintenance, maintenance and frequency are carried out in accordance with the manuals for the manufacturers of technical equipment of the ACS of the KKKH (central part).

Requirements for protection from external influences

The technical means of the ACS CCTV (central part) should be designed for operation in closed, non-heated and ventilated rooms - in accordance with SNiP 2.04.05-91 "Heating, ventilation and air conditioning".

On protection from environmental influences, the technical means of the ACS of the KKKH (central part) should be of the usual design, with a degree of protection in accordance with GOST - 14254 - 80.

In terms of resistance to temperature, humidity and atmospheric pressure, the technical means of the ACS of the CTCT (central part) should be designed for operation under the following conditions:

ambient air temperature - from -15°C to $+40^{\circ}\text{C}$;

- relative air humidity - from 30% to 80% at a temperature of $+35^{\circ}\text{C}$ and lower temperatures without condensation of moisture;

- atmospheric pressure - from 84kPa to 107kPa.

The technical means of the ACS of the KKKH (central part) should remain operative in the presence of permanent or variable, frequency 50 Hz, magnetic fields of not more than 40A / M.

Requirements for standardization and unification

The control system must ensure the functioning of the technological object within the limits of the regulatory norms.

On the monitor screens, the information is presented as separate groups, messages, mnemonic fragments, graphs and tables.

Operative display of information should provide a sufficient picture of the process. Information on the display screen should be updated with a period of not more than 5 seconds for the survey frames and not more than 2 seconds for the frames of the control loops.

Signaling of pre-emergency situations should appear as they arise.

Trends should provide simultaneous display of up to 5 parameters in the interval from 20 minutes to 30 days.

In the control loop, up to 8 groups of parameters of the same type of control loops should be displayed in alphanumeric form and in the form of vertical histograms. In each group of parameters of the control loop, the following information should be displayed:

- the current value of the parameter;
- the current value of the job;
- the value of the control action on the actuator;
- engine operation mode;
- signaling about the output of the parameter for routine and / or pre-emergency values (color change);

Mimic diagrams should be both aggregated and detailed for each node. When the parameter leaves the regulatory or pre-emergency borders, the inscriptions, numbers and histograms on the mnemonic diagrams must change color, and this event must be accompanied by an audio message.

Requirements for the functions performed by the system

ACS CCTV should perform the functions of information, control and emergency.

Information functions:

- computational and logical functions of information character;
- automatic registration of current values of technological parameters and the status of actuators;
- automatic control and recording of commands and actions of the operator during start-up, operation and normal shutdown of equipment;

- automatic detection and display of (emergency and precautionary) values of technological parameters and equipment condition indicators on the screens of operator station monitors;
- display and registration of the original cause of an emergency stop;
- diagnostics of the serviceability (state) of the control equipment of the ACS of the KKKH;
- sound notification of deviations or disturbances in the technological process;
- the supply of sound and light signals when the warning and alarm system is activated.

Control functions:

- automatic program start-up of ASU CTCT equipment;
- automatic program stop (normal and emergency) of ACS CTCT equipment;
- change of current values of technological parameters in manual mode;

Remote control of auxiliary electrical equipment, regulating equipment;

- operation of process equipment without the constant presence of operating personnel;
- the possibility of stage-by-stage launch of the ACS of the KKKH during the commissioning works.

Emergency functions:

- automatic protection of the equipment of the ACS of the KKKH by means of its emergency stop;
- formation of necessary technological interlocks;
- prohibition of the execution of commands that are not provided by the control algorithm;
- emergency stop of the ACS of the KKKH on the initiative of the operator;

the possibility of a manual stop of the ACS CCTV by the operator in emergency situations;

- the possibility of stopping ACS QCTC with the disappearance of the voltage of the main power source;
- control of the presence of supply voltages.

Requirements for mathematical support

The software of the microprocessor controller must provide the following functions for primary processing of analog signals:

- calculation of actual values;
- signal filtering (averaging);
- comparison with set-points (technological boundaries);
- formation of discrete signals of violations;
- formation of an array of current parameter values.

Mathematical support of microprocessor controllers, in addition to functions for processing current information, must perform control and emergency functions, which include:

- automatic program start-up of ASU CTCT equipment;
 - automatic program stop (normal and emergency) of ACS CTCT equipment;
 - automatic control of technological parameters;
 - remote control of auxiliary electrical equipment and regulating equipment;
 - automatic protection of ACS of the KKKH by means of its emergency stop.
- Adjustment of control systems should be carried out by setting the appropriate coefficients.

The software should ensure the fulfillment of the main functions of the ACS of the KKKH, the functions of storing and presenting information. For this it is necessary to provide:

- development of a general algorithm for the operation of the ACS of the KKKH;
- Development of algorithms for automatic start-up of well equipment;
 - Development of algorithms for automatic start-up of pumping station equipment;
 - Development of automatic stopping algorithms (normal and emergency);
 - Development of algorithms for emergency protection;
 - creation of a database on the technological process;
 - Development of algorithms for collecting and initial processing of analog information;
 - Development of technological control algorithms;
 - Development of algorithms for recording equipment status;

- Development of algorithms for displaying information to the operator-technologist;
- Development of algorithms for polling microprocessor controllers;
- development of algorithms for issuing tasks to the microprocessor controller;

Development of algorithms for diagnosis of microprocessor controllers.

Requirements for information support

The ACS CCTU database should be formed by filling in the standard forms on the screen of the video terminal on the basis of the list of control and regulation channels. Calling forms should be done using a system of nested menus. The menu should provide:

- description of the system;
- description of the controller;
- description of the display system;
- description of analog signals;
- Description of discrete signals;
- description of the logging;

The description of analog signals should determine signal connection in the system, signal processing parameters, averaging characteristics, inclusion of parameter values in the report-report, formation of the history of the contour parameters at the specified time interval, control for reliability.

The description of the discrete signals should contain information about the parameter connection to the system, the indication of the inclusion of the parameter values in the emergency table in case of a change in the value of the input signal, the normal value (state) of the parameter.

The description of logging and printing should contain a description of the violation table, a description of the report-report, a description of the archive trend, a description of the logging of parameter values entered by the operator into the controller's RAM.

It is necessary to provide recording of the actions of the operator to change the task, the operating mode of the control loops, the issuance of discrete control actions (start, stop, open, close) and record the protocol on PC media.

To configure the system and create a database, it is necessary to provide modes for correcting the database. Correction of the database should be carried out in the

autonomous mode of operation of the PC or on the instrumental PC. The following requirements are imposed on the image on mnemonic circuits, as a means of man-machine interface in industrial conditions:

- an average degree of detail with at least eight colors in order to allow easy recognition of production situations;
- change of the state of technological variables is transformed into a change in the display of the corresponding elements of the mnemonic scheme (color, flicker, filling).

It is necessary to organize a change in the illumination of the corresponding element of the mnemonic scheme in the event of a change in the state of the discrete parameter.

Log into the frame of the mnemonic diagram should be performed by the mnemonic calling keys.

Provide the possibility to control the control loops from the mnemonic scheme through the control window.

Archiving process history

To monitor the change in the status of process parameters, you must organize the storage of the history of the parameter values.

Provide an archive of analog parameters:

- archive of instantaneous parameter values;
- archive pre-emergency and after emergency situations;
- archive of averaged parameter values for a day;
- an archive of hourly average values of parameters on a monthly interval.

At the initiative of the operator, the historical trend in the form of graphs should be displayed on the display screen.

Viewing trends should not prevent the operator from controlling the process.

Formation of the accounting documentation

Protocols of violations and events

In the operational control mode, a protocol of violations of the regulatory and pre-emergency boundaries should be formed. The operator should be able to view the protocol on the screen of the video monitor at any time. In the protocol, the ciphers,

the names of the parameters that have exceeded the boundaries, and the values of these limits for the analog parameters, as well as the time and date of the violation occurrence, shall be fixed in the chronological order from the beginning of the change. For discrete parameters, a state change must be recorded.

Software Requirements

The software of the ACS CCTV must be sufficient for the implementation of all functions of the system and is divided into software of microprocessor devices of a certain purpose (converters, controllers) and software of the operator station. The system software is supplied together with the BT means.

Specialized and applied software are developed at the stage of development of information, mathematical and software and are delivered to the CUSTOMER on the specified information carrier. The following requirements are imposed on the image on mnemonic circuits, as a means of man-machine interface in industrial conditions:

an average degree of detail with at least eight colors for easy recognition of production situations;

- change of the state of technological variables is transformed into a change in the display of the corresponding elements of the mnemonic scheme (color, flicker, filling).

It is necessary to organize a change in the illumination of the corresponding element of the mnemonic scheme in the event of a change in the state of the discrete parameter.

Log into the frame of the mnemonic scheme should be performed using the mnemonic calling keys.

It is necessary to provide the possibility of controlling the control loops from the mnemonic circuit through the control window.

Requirements for technical support

The technical means offered for use in the ACS of the RCP should fully satisfy all the requirements set forth in this TOR and be able to perform all the functions described in acc. Sections of this TOR.

The technical means of the ACS of the CTCX consist of the following components:

- microprocessor controllers;

- Visualization systems based on computers of industrial design;

- power supply systems.

As part of the technical means of ACS CCTV, microprocessor controllers and industrial computers compatible with IBM PC AT should be used, which will be used as workplaces for production operators.

Technical characteristics of the technical means of the system used must ensure the interchangeability of the same technical means without any changes or adjustments in other devices.

The devices and means of automation used in the system must correspond to the parameters of the power supply of GOST 721-77.

The technical means used in the system must meet the reliability requirements. The level of industrial radio interference created by the technical means of the system during operation, as well as at the moment of switching on and off, should not exceed the values stipulated by the "All-Union norms of permissible interference" No. 1-72-9-72.

The noise level created by the technical means should not exceed 75 dB at the locations of the operational personnel at the frequency range 600-1200 Hz under GOST 12.1.003-83.

Technical means of the system must meet the safety requirements in accordance with GOST 12.2.007-75 and GOST 12997-84.

All external elements of the technical facilities of the system, which are under voltage, must be protected against accidental touches, and the technical means themselves - have protective earthing in accordance with the EMP.

Characteristics of the maintenance and repair system, as well as the requirements for maintenance and repair facilities, should be given in the technical description and operating instructions of the system.

ACS CCTV should be equipped with a set of spare parts in accordance with technical conditions for technical facilities.

The entire set of technical means of the ACS of the KKKH (central part) with the disappearance of power supplies should remain operable (observability and controllability) for at least 1 (one) hour using the UPS uninterruptible power supply unit with a power reserve of 30% of the nominal capacity.

Requirements for metrological characteristics of measuring channels

Metrological characteristics of measuring channels are determined and normalized in the process of metrological certification in accordance with DSTU3215-95, DSTU2682-94, DSTU2708-94, GOST 12997-84, GOST8.010-90.

The automatic control system should have the following metrological characteristics (without taking into account primary converters):

- limits of the allowed basic reduced error of the temperature measuring channels - not more than 0.5%;
- the limits of the permissible main reduced error of pressure measuring channels, pressure drop, level - no more than 0.5%;
- the limit of the permissible relative error of the channels for receiving the measurement of the rotational speed - not more than 0.1%;
- the total limit of the permissible relative error for determining the volume flow is not more than 1.0%.
- the limit of the permissible relative error of the channels for receiving the measurement of currents and voltages is not more than 0.5%.

To maintain the technological process, the accuracy class of primary measuring transducers should be as follows:

- the accuracy class of the measuring transducers participating in the measurement of temperature must be at least 0.5;
 - the accuracy class of the measuring transducers involved in measuring the pressure, pressure drop, level, should not be less than 0.5;
 - the accuracy class of the measuring transducers participating in the measurement of the rotational speed must not be less than 0.1;
- the accuracy class of the measuring transducers participating in the flow measurement shall be not less than 1.0;
- the accuracy class of the measuring transducers involved in measuring the currents and voltages of the motors must be at least 0.5.

The basic error is normalized under the following operating conditions:

- ambient air temperature - $+ 20 \text{ }^{\circ} \text{C} \pm 5 \text{ }^{\circ} \text{C}$;
- Relative air humidity - from 30% to 80%;
- atmospheric pressure - from 84 to 107 kPa;
- supply voltage $220\text{V} \pm 10\%$;
- frequency $50 \pm 1 \text{ Hz}$;
- absence of external electric and magnetic fields;
- No vibration, shaking, bumps.

The change in the error caused by the change in ambient temperature from the boundaries of the normal range (from $15 \text{ }^{\circ} \text{C}$ to $25 \text{ }^{\circ} \text{C}$) to any temperature in the range from $5 \text{ }^{\circ} \text{C}$ to $50 \text{ }^{\circ} \text{C}$ should not exceed 0.5 of the absolute value limit of the basic error limit for every $10 \text{ }^{\circ} \text{C}$.

The technical documentation for the system should contain the following documents:

- program of metrological certification of measuring and computational channels;
- method of calibration of measuring and computational channels;
- Method of metrological verification of channels during operation.

Requirements for methods and means for testing and testing the measuring channels of the ACS of the KKKH

The following requirements are imposed on the methods and means for testing and verifying the measuring channels:

- As standard measuring instruments for monitoring the metrological characteristics of measuring channels, serially produced reference devices should be used. All measuring IR ACS CCTV are subject to periodic verification;
- The IKs are verified in a comprehensive manner, including all primary measuring transducers and information display devices in accordance with GOST 8.438-81;
- IR input signals at the verified points of the measuring range must have a fixed value of the technological parameter or be imitated with an exemplary measure;
- verification should be carried out with the help of commercially available measuring instruments, which are determined by the methods of checking the measuring components of the IR;
- methodical instructions for verification of the IR should provide for their verification in a comprehensive manner in accordance with GOST 8.326-89;
- after verification, any change in the structure of the IR is not allowed without the permission of the departmental metrological service.

The ICs and ISs created as part of the ACS CCT are subject to metrological certification at the facility in accordance with the established procedure by the Dnipropetrovsk State Center for Standardization of Metrology and Certification (DGTSSMS).

1.5. Composition and content of the work on the creation of the ACS of the CTCT

Table 1.1 - Composition and content of works on the creation of the ACS of the CTCT

N n/n	Name of stages of work	Deadline	Executor
1.	Development of technical specifications	According to the calendar plan	Art. Gr. IA-63 Levichev A.
2.	Development of system-wide solutions	According to the calendar plan	Art. Gr. IA-63 Levichev A.
3.	Development of information support	According to the calendar plan	Art. Gr. IA-63 Levichev A.
4.	Development of mathematical and software for microprocessor controllers	According to the calendar plan	Art. Gr. IA-63 Levichev A.
5.	Development of technical support for automated control system	According to the calendar plan	Art. Gr. IA-63 Levichev A.
6.	Development of organizational support	According to the calendar plan	Art. Gr. IA-63 Levichev A.

N n/n	Name of stages of work	Deadline	Executor
7.	Supply of equipment for automatic control system of the central control system. Step 1	After 100 days After translation Advance payment	customer
8.	Installation of automated control system	2 months later After delivery Of equipment	customer
9.	Commissioning of the central part of the ACS of the KKKH	2 months later After graduation Installation works	customer
10.	Shemontazh ASU CKT	According to the calendar plan	customer
11.	Starting-up and adjustment works of the lower Level of ACS	According to the calendar plan After 30 days	customer
12.	Complex adjustment of ACS CCTV	After the signing of the act by the working committee	customer

1.6 Requirements for the composition and content of work on the preparation of an automation object for the commissioning of the system

When preparing an object for the implementation of the ACS of the KKKH, the enterprise operating the system should:

- Ensure the readiness of the facility for installation work on the creation of the ACS of the KKKH;
- Ensure the organization of the technical maintenance department of the ACS of the KKKH;

to perform input control of the ACS of the KKKH for completeness and compliance of technical documentation to the project;

- perform adjusting and state verification ASU KKKH;
- Together with specialized organizations to carry out engineering supervision of the installation of parts of the ACS of the KKKH;
- to organize, with the involvement of the developer, the technical training of operative and repair personnel for the operation rules of the ACS of the KKKH;
- to organize and conduct acceptance tests of the ACS CTCT with the participation of the developer, co-executors and the customer;

Implement changes in the technological scheme of the facility, proposed by the developer of the ACS of the KKKH and agreed with the project organization.

NOTE: The customer performs the above work.

1.7 Documentation requirements

The types and completeness of the documents for the ACS of the KKTH are regulated by the provisions of GOST 34.201-89.

Development is subject to:

- system-wide design solutions;
- a set of documents of organizational support;
- a set of documents of mathematical support;

- a set of software documents;
- set of documents of information support.

The content of the technical specification sections can be specified in the established order by protocols (subsection 3.3 of GOST 34.602-89) in the process of developing and commissioning the ACS of the KKKH without introducing changes to the terms of reference.

1.8 Sources of development

GOST 34.602-89 Information technology. Terms of Reference for the creation of an automated system.

"Initial requirements for the creation of an automated control system for a water intake junction"

"General rules of explosion safety for explosive chemical, petrochemical and oil refineries". OPVB - II, Moscow, Nedra, 1982.

"Rules for the installation of electrical installations" sixth edition, 1985.
 "Rules of technical operation of electrical installations of consumers" the fourth edition, approved on December 21, 1984

0.00-1.21-98 "Rules of safe operation of electrical installations of consumers".
 OST 36.13-90 "Shields and panels of systems of automation of technological processes".

Organization that order is spent."

GOST 12.1.003-83 "Occupational Safety Standards System - Noise - General Safety Requirements".

GOST 12.2.007-75 "Electrotechnical products - General safety requirements".

GOST 12997-84 "GSP products - General specifications".

GOST 34.201-89 "Types, completeness and designation of documents when creating automated systems".

GOST 22315-77 "Means of aggregation of information-measuring systems - General provisions".

GOST 14254 - 80 "Electrotechnical products - Shells - Degrees of protection - Designations - Test methods".

2. Description of the object of automation and the algorithm of its functioning

The architecture of the developed system has two levels: the lower one - the control subsystem (sensors, microcontroller, actuators and equipment) and the upper one - the operator's post (personal computer). Communication between the levels is carried out via the RS-485 interface. Implementation of control algorithms is carried out with the help of an automated top-level module, which is also responsible for the interface on the operator's post (Figure 2.1).

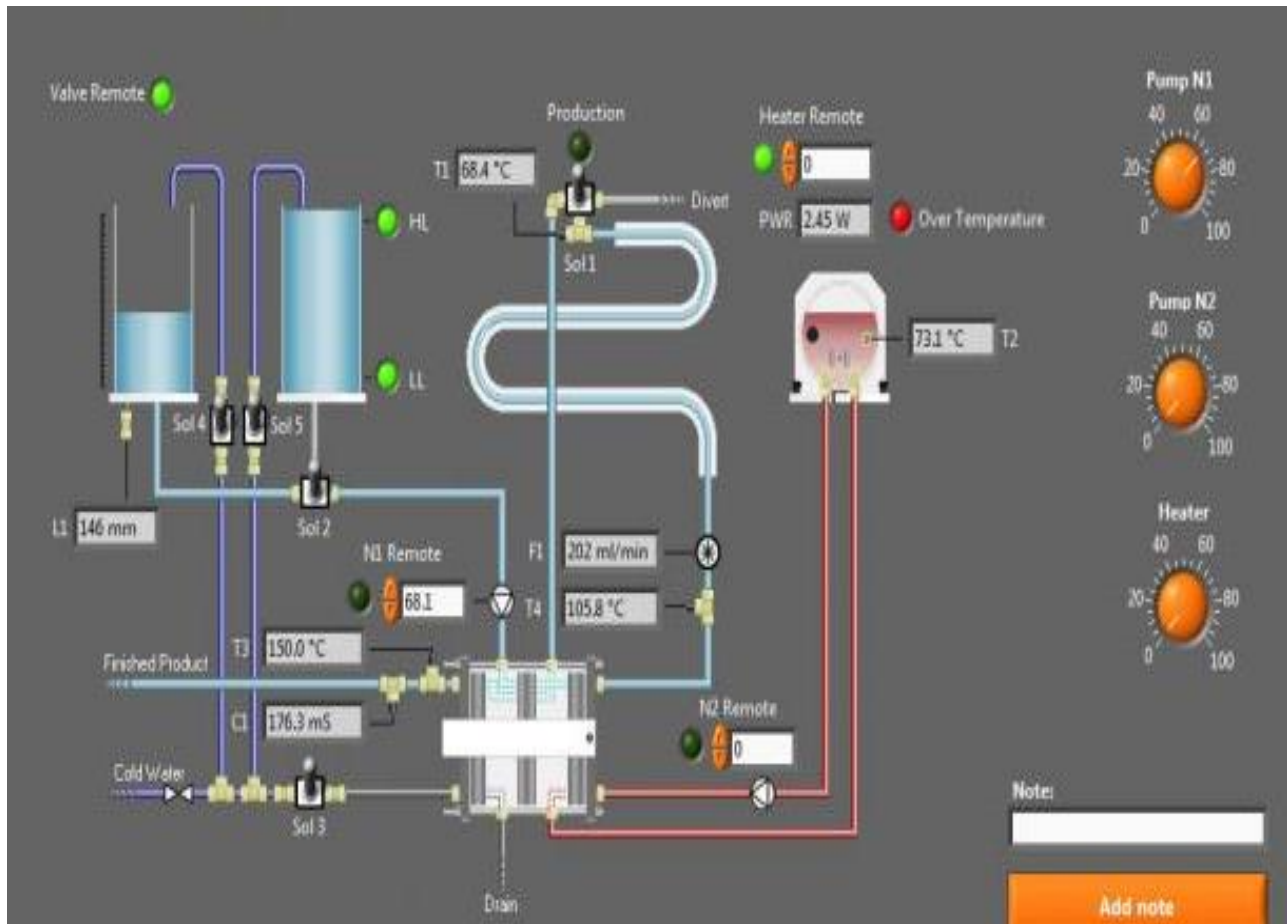

Figure 2.1 - Mimic diagram of the process control system
The structure of the hothouse economy includes the following main technological installations and systems:

- Air conditioning;
- Room heating system;

- Monitoring of climatic conditions in the room;
- Power supplies for monitoring and control systems;
- Temperature and humidity sensors;
- Operator control panel;
- Filter;
- Pump;
- Controller;

3. Analysis of the system requirements

A complete list of requirements for a climate management and control system in greenhouse farms can be divided into a number of subgroups. Among them:

- requirements for the structure of the system;
- requirements for functioning;
- requirements for the number and qualifications of staff;
- requirements to the indicators of destination;
- reliability requirements;
- requirements for ergonomics and technical aesthetics;
- requirements for the operation, maintenance, repair and storage of system components;
- requirements to protect information from unauthorized access;

Requirements for protection from the influence of external influences;

- requirements for standardization and unification;

The main requirements are for the structure of the system and its functioning, which will be considered below.

The architecture of the developed system has two levels: the lower one - the control subsystem (sensors, microcontroller, actuators and equipment) and the upper one - the operator's post (personal computer). Communication between the levels is carried out via the RS-485 interface. Implementation of control algorithms is carried out using an automated top-level module, which is also responsible for the interface on the operator's post.

3.1 System Structure Requirements

The automated system of climate control and control in greenhouses is based on microprocessor technology.

According to the hierarchical principle of ACS, the QCTC should be divided into levels:

Lower level:

- regulators of humidification nozzles, opening of the water supply valve, switching on and off of the heating system, and air conditioning;
- sensors for air temperature, humidity;
- devices of light and sound signaling of unauthorized entry into the territory of the greenhouse;
- Regulatory and other enforcement mechanisms;
- microprocessor controllers for monitoring and controlling the regulators of the humidification nozzles, opening the water supply valve, switching on and off the heating system and the air conditioner.

top level:

- operator station (operator's workplace).

Automated control and management of climate control equipment in greenhouse farms can be carried out without the constant presence of operating personnel in the area of deployment of technological equipment.

Communication between the components of the system must be carried out through physical and interface channels.

ACS CCTV must be connected to a guaranteed power supply system using uninterruptible power supplies.

Each operator station must include:

A standard configuration computer:

- RAM 128 MB, a floppy disk drive, a hard disk drive with a capacity of 10-20 GB;
- one color monitor;
- technological keyboard;
- manipulator type "mouse".

The technological keyboard is designed for operational control of the process and should have a set of function keys programmed to the display videograms and allowing uniquely execute the process control commands. The keyboard should be comfortable and easy to use.

3.2. System operation requirements

ACS CCTV should:

- to ensure the efficient operation of process equipment without the constant presence of operating personnel in the area of equipment deployment with a minimum number of manual operations and safe working conditions;
- Increase of productivity of a hothouse due to rigid automatic maintenance of required parameters of a microclimate;
- ensure high reliability of automatic regulation and control of the technological process due to the use of modern hardware and software;

provide service personnel with timely and reliable information on the progress of the technological process;

- provision of personnel with reliable and timely technological information;
- ensure a reduction in energy consumption;
- provide light and sound alarms in case of unauthorized access to the territory of the VZU, into the pavilions of wells, as well as removal of hatches from the reservoir.

ACS CCTV should also provide interaction with:

- systems for collecting and processing information - through physical communication channels.
- executive mechanisms and aggregates - through physical communication channels;
- operator control panel - via RS-485 network.

4. Review of existing decisions and justification of the choice of the accepted principle of construction of the projected system

Almost all greenhouse farms are built according to a single scheme: a heat-insulated room in which to the desired values with the help of a heating system, a system of spraying plants, temperature sensors for air and water (for irrigation), soil moisture, and air.

Greenhouse farms differ only depending on the object of cultivation.

Those. The difference between the technical heating system of the room, the humidification system, and so on. The collection of information will take place across all the main OSs necessary for the successful accomplishment of the assigned tasks. According to these parameters, the operator will make management decisions.

The effectiveness of the ACS of the CTCT will depend to a large extent on how it will be designed. The hothouse economy will be fully automated, except for cases of either too strong an unintended impact on this system, or in cases of unauthorized intervention in the operation of the system.

The control systems of the space shuttle can differ only in the level of automation, i.e. Quantity and quality of the object's adjustable parameters. The scheme of the systems remains constant in most cases. This is largely due to a number of requirements for ACS VCU from GOSTs and SPINs. Among such requirements can be identified the following:

General provisions (SNiP 2.10.04-85);

- Volumetric-planning and constructive solutions (ONTP-CX.10-81);
- Water supply, drains and drainage (ONTP-SH, 10-81);
- Heating and ventilation (SNiP II-33-75);
- Electrotechnical devices (ONTP-CX.10-81).

4.1 General

Greenhouses should be designed as single-span or multi-span. The type of greenhouses for each zone is determined by the feasibility study. Greenhouses should be designed with a single-skinned or two-slope coating.

Auxiliary premises for those working in greenhouses and greenhouses should be designed in accordance with the requirements of SNiP II-92-76. Geometric parameters of greenhouses and greenhouses should be assigned in accordance with

the technological part of the project. Greenhouses should be designed with a wooden or metal frame in accordance with the requirements of TP 101-81. Greenhouses need to be designed with a wooden or reinforced concrete frame.

Translucent fences of winter greenhouses should be designed from glass or film, as a rule, two-layer or single-layer with an additional transformable curtain or heat shield, and spring greenhouses - from the film, taken for the winter period. In the walls of greenhouses, intended for growing seedlings, planted in open ground, it is necessary to provide ventilation openings.

4.2 Water supply

Norms and regime of water consumption, quality and temperature of water for irrigation and other technological purposes should be adopted in accordance with the requirements of the ONTP-CX. 10-81.

When designing water supply systems for greenhouses and greenhouses, it is necessary to follow the instructions of SNiP 2.04.01-85 and SNiP 2.04.02-84, taking into account the requirements of this section. For watering in greenhouses and for other production purposes, it is allowed to supply drinking water at justification.

If fertilizer or other substances are supplied to the production pipeline network, it must be connected to the household drinking water supply with a jet rupture of at least 50 mm from the maximum water level in the tank or in the tank to the bottom of the supply pipeline. Provide for internal and external firefighting of greenhouses and greenhouses should not be. The internal water supply of the greenhouses must be connected to the external one, as a rule, by one input. The water supply in the greenhouses should be equipped with injectors or drippers for watering the soil, air humidification jets, as well as cranes for irrigation, washing driveways and other technological purposes.

In greenhouses intended for growing vegetables on artificial substrates, the water supply must be equipped in accordance with the requirements of technology. The water supply of the greenhouses should have watering faucets.

Constant free head of water in the pipelines at the injectors and droppers, the zones of their action and other characteristics necessary for designing, should be taken according to the manufacturers' data. Cranes for irrigation should have a nominal diameter of 20 mm. The radius of the service area by one crane should not be more than 45 m.

Internal networks of water pipes and gutter drains should be designed, as a rule, from non-metallic pipes; Combs, shaped parts, their connections and in substantiation the main pipelines, laid along corridors and greenhouses, are made of metal.

Internal networks of water pipes and gutter drains can be laid on the surface of the earth and in the ground.

Pipelines should have devices for emptying.

At the inputs to the greenhouses should be provided for the installation of water meters. It is allowed to install water meters for a group or a block of greenhouses.

The shut-off valves must be installed at the inputs to the greenhouses and on branches from the main pipelines of greenhouses and greenhouses.

Irrigation management should be provided, as a rule, remote for a given program. The reliability category of water supply systems for greenhouses should not be lower than II, greenhouses - not lower than III according to SNiP classification 2.04.02-84. Multiple-span winter greenhouses should be designed, as a rule, with internal gutters to remove atmospheric precipitation from the coating trays. Multiple-span spring and single-span spring and winter greenhouses need to be designed without internal gutters.

The estimated costs of rainwater in the hydraulic calculation of trays on the roofs of greenhouses and inland drainage networks should be determined by the method of limiting intensities. In this case, the period of a single excess of the rain intensity in the calculation of internal watercourses should, as a rule, be taken equal to 0.5 years. Depending on the hydrogeological conditions of the construction site, it is necessary to provide for closed drainage in winter ground greenhouses and in seedlings of spring greenhouses.

The distance from the design mark of the soil surface to the top of the drainage should be at least 0.7 m. The drainage device in the greenhouses is not allowed.

Drainage should ensure the optimal air-moisture regime of the root layer, timely drainage drainage in accordance with the requirements of ONTP-CX.10-81, as well as prevention of groundwater contamination with pesticides and mineral fertilizers.

4.3 Heating and ventilation

Heating and ventilation of greenhouses and greenhouses should be designed in accordance with the instructions of SNIIP II-33-75 and taking into account the norms of this section.

Heating and ventilation of greenhouses and greenhouses in conjunction with other systems should provide them with microclimate parameters (air and soil temperature, relative humidity and internal air speed) established by the requirements of ONTP-CX.10-81. Greenhouses should be equipped with a ventilation system. The need to install a heating system for greenhouses and greenhouses, as well as its power should be determined by calculation. Heat supply of greenhouses and greenhouses should be carried out due to secondary energy resources, heat of geothermal waters, in the absence of these sources - from TPPs, nuclear power plants and thermal power stations or own heat sources.

When using secondary energy resources for heating greenhouses, it is allowed to apply. The calculated parameters of the internal air and the right temperature of the greenhouses should be in accordance with the requirements of ONTP-CX.10-81. Calculated parameters of outside air should be in accordance with SNIIP 2.01.01-82:

A) in the cold season for winter greenhouses - the average temperature of the coldest days with a security of 0.92, the average relative humidity of the coldest month and the average wind speed in January; For spring greenhouses - the average temperature of the coldest month during the operation period, reduced by half the maximum daily air temperature amplitude, the average relative humidity and the average wind speed in this month;

B) in the warm period of the year (for all greenhouses) - the average temperature and average relative humidity of the hottest month, the average wind speed in July. Heating and ventilation of greenhouses and greenhouses should be designed taking into account the heat input accumulated by the soil during the daytime (the cold season) and from solar radiation (the warm period of the year).

When calculating water heating, it is necessary to take into account the radiant component of heat transfer by heating devices (pipes) and the change in heat transfer along their length.

In winter greenhouses should be provided water heating or water in combination with air (combined heating) and water heating of the soil. Combined heating system should be provided, as a rule, in areas with an outside temperature of the coldest day minus 20°C and lower, in other areas, its application should be justified. The thermal power of air heating in the combined heating system should be taken in single-span greenhouses equal to 35-50%, in multi-span - 20-40% of the total heat consumption in the calculation period.

Openings for natural ventilation (inflow and removal of air) in multi-span greenhouses with a width of more than 25 m should be placed in the cover - along the skates, in all single-span and multi-span widths less than 25 m - in the outer walls (for inflow) and in the cover (for removal). Opening and closing ventilation openings must be mechanized. In greenhouses with air heating, it is necessary to provide for the use of heating fans for ventilation during the warm season. Ventilation of hotbeds is carried out by lifting (opening) of greenhouse frames or film coating. In single-spaced greenhouses, the areas of intake and exhaust openings for natural ventilation should be determined by calculation. In multi-span greenhouses intended for growing vegetables, the total area of openings for natural ventilation should be taken: in regions north of 60°N . W. - not less than 10%, in other areas - not less than 20% of the total surface of the fencing of greenhouses. In multi-span greenhouses intended for growing seedlings (planted in open ground), the total area of openings for natural ventilation should be taken in accordance with the requirements of the technology.

4.4 Electrical devices

Electrotechnical devices should be designed in accordance with the rules of electrical installation (PUE) of the Ministry of Energy of the USSR. Categories of electrical receivers to ensure the reliability of electricity supply to greenhouses and greenhouses should be taken in accordance with the requirements of ONTP-CX.10-81. In the passage of greenhouses and corridors, it is necessary to provide artificial lighting mainly with fluorescent lamps; Illumination at the floor level should not be more than 10 lux. Irradiation of plants should be carried out by highly effective irradiation devices in accordance with the requirements of ONTP-CX.10-81. The distance between the irradiators and the height of their suspension must be determined by calculation. Laying of distribution networks in greenhouses from cables and wires in plastic pipes should be carried out openly on trays.

5. Description of the developed solution of the control system ensuring the fulfillment of the requirements of the technical task

5.1 Equipping a green house

To ensure compliance with the requirements specification, it is proposed to provide reliable centralized control by means of sensors that are directly connected to the industrial controller and control elements.

The air temperature will be measured with the help of KTY-81-210 sensors. The sensors are placed in a special leaded plastic housing. These sensors have a small level of error and are suitable for this project. The measurement of the water temperature in the tank will be carried out with the help of sensors numerix ETF-01. Submersible temperature sensors are installed directly in the pipeline to measure the temperature of the water (or other coolant) in the heating, ventilation and air conditioning systems.

Signals from water level sensors, air and water temperatures, soil and air humidity, water flow, and water level of the tank are fed to the Modicon 984 - 685 industrial microcontroller. The sensors are powered by an additional power supply. Air humidity measurement will be performed using Honeywell HIH-3602 sensors. The sensors carry out continuous twenty-four-hour measurements of the relative humidity of the air and the maintenance of predetermined regimes. Measurement of soil moisture will be carried out using sensors Gardena. The required humidity is set by means of a rotating regulator. Indication of the actual moisture content of the soil. Equipped with a 5 m connecting cable with a plug.

Sprinklers are used to control the humidity of the air and soil. To maintain a normal temperature regime, central water heating is used.

5.2 Greenhouse equipment

In the electrical room of the pumping station of the second lift, a cabinet will be installed with equipment responsible for controlling frequency regulators, measuring the flow and pressure of water at the outlet of the pumping station, measuring the water level in the tank, and switching on / off and measuring the currents of fire pumps.

To control humidity and temperature, sprinklers (4191 companies JHi I.S) are used for spraying soil and air, as well as a water heating system (hot water supply from the boiler room).

As a humidity sensor, Honeywell's HIH-3602-L sensor is used.

The sensor DRC-4 is designed to measure the flow and volume of water in pipelines.

Output signals from the level, pressure and current sensors are sent to the industrial controller Modicon 984 - 685.

The equipment is mounted in a Schroff rack with a size of 600 - 600 - 320/1 /.

5.3 Central Operator Station

The central post of the operator is a complex of technical facilities located in the operator's room. It includes a cabinet with equipment, a monitor and a management console.

As an administrator in the system, an industrial computer is used that includes a RAS-40H chassis with a passive backplane, a PCA-6154 processor card with a DiskOnChip flash disk, 32 MB of RAM and a Pentium 150 MHz processor. In the cabinet an industrial computer with communication boards is mounted, an uninterruptible power supply unit.

The switchboard is connected to the operator's central post by the RS-485 channel.

6. Description of collateral types

Based on the terms of reference, the following main types of support for the developed control system can be distinguished:

- mathematical;
- information;
- ensuring the safety of information;
- software;
- technical;

Next, we will consider the mathematical and informational, since In the project they are practically not clearly expressed.

6.1 Software

The software of the microprocessor controller must provide the following functions for primary processing of analog signals:

- calculation of actual values;
- signal filtering (averaging);
- comparison with set-points (technological boundaries);
- formation of discrete signals of violations;
- formation of an array of current parameter values.

The first two points are provided by the analog input modules of the controllers. The latter are by the controllers themselves, in accordance with the recorded work program.

The mathematical support of microprocessor controllers, in addition to functions for processing current information, also performs control and emergency functions, which include:

- automatic software start-up of equipment;
- automatic control of technological parameters;
- remote control of regulating equipment.

Adjustment of control systems is done by setting the appropriate coefficients. Mathematical support, in addition to these tasks, ensures the performance of the main

functions of the ACS of the KKKH, the functions of storing and presenting information. For this, algorithms are implemented:

- functioning of ACS of the KKKH;
 - automatic start-up of TX equipment;
 - automatic control of sprinklers;
 - automatic control of water supply to the tank;
 - creating a database on the technological process;
 - collection and primary processing of analog information;
- Averaging and integration of parameters;
- technological control;
 - accounting equipment status;
 - display of information to the operator-technologist;
 - interrogation of microprocessor controllers;
 - issuing tasks to the microprocessor controller;
 - Diagnostics of microprocessor controllers.

6.2 Information support

The ACS KKKH database is formed by filling in the standard forms on the screen of the video terminal on the basis of the list of control and regulation channels. Calling forms is done using a system of sub-menus. The menu provides:

- description of the system;
- description of the controller;
- description of the display system;
- description of analog signals;
- description of the logging;
- description of the notification and signaling subsystem.

The description of analog signals should determine signal connection in the system, signal processing parameters, averaging characteristics, inclusion of parameter values in the report-report, formation of the history of the contour parameters at the specified time interval, control for reliability.

The description of logging and printing should contain a description of the violation table, a description of the report-report, a description of the archive trend, a description of the logging of parameter values entered by the operator into the controller's RAM.

It also provides for recording the actions of the operator to change the job, the operation mode of the control loops, the issuance of discrete control actions (start, stop, open, close) and record the protocol on PC media.

The used mnemonic schemes can be constructed from the following elements:

- alphanumeric characters;
- standard technological symbols (valves, pumps, tanks, etc.);
- graphic symbols;
- vectors, arcs, circles;
- shaded areas.

Modes for adjusting the database are provided for configuring the system and forming the database. Correction of the database is performed in the autonomous mode of operation of the PC or on the instrumental PC.

7. Development of a database of control and regulation parameters

All the main and auxiliary parameters used in controlling the ACS of the KKKH are summarized in Table 7.1. The table shows the upper and lower limits of their limit values, units of measurement, controllers used for the initial conversion and filtering of parameters and their number.

Table 7.1 - Measured physical quantities of ACS QCTC

Regulation parameter	Unit. Amend.	Min.	Max.	Controller	Number
Air humidity	%	0	100	HHH-3602	1
Moisture of soil	%	0	40	GARDENA	8
Air temperature	t°	0	70	KTY-81-210	1
The water temperature in the tank	t°	0	60	ETF01	1
Water level in the tank	m	0	3	SML-PS1	1
Water flow rate	m ³	0	20	DRC-4-OP	1

8. Description of the scheme of functional electrical automation

The automatic system for monitoring and managing the water intake junction can be conditionally divided into three components:

- control system TX;
- operator's workplace.

The first subsystem is shown in the functional automation scheme in an explicit form, the latter in the form of a table designation of the computer. The equipment includes sensors installed in the field, actuators, devices installed on the switchboard. All designations of instruments and automation equipment are complied with in accordance with GOST 21.404-85.

9 Selection and justification of individual units and elements

9.1. The humidity sensor

By the required accuracy of measurement, which is determined by the accuracy of maintaining humidity $\Delta_y = \pm 3\%$ and the coefficient $\lambda = 0,4$

And the set range of variation of the controlled variable, select the Honeywell HIH-3602-L sensor (figure 9.1).

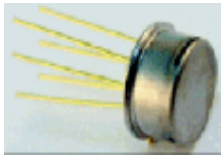

Fig. 9.1 - The appearance of the humidity sensor

The sensors of this series are intended for use in multi-channel automated systems for monitoring the microclimate parameters on the basis of a PC, which perform continuous 24-hour measurements of the relative humidity of air and the maintenance of predetermined regimes.

At present, in practice, several technologies are used to measure the relative humidity using the property of different structures to change their physical parameters (capacity, resistance, conductivity and temperature) depending on the degree of saturation with water vapor. Each of these technologies has certain advantages and disadvantages (accuracy, long-term stability, conversion time, etc.).

Among all types of capacitive sensors, due to the full range of measurement, high accuracy and temperature stability, have become most common, both for measuring the humidity of the ambient air and for use in production processes.

Honeywell manufactures a family of capacitive humidity sensors using the multilayered structure method (Fig. 5), formed by two flat platinum plates and a dielectric thermosetting polymer filling the space between them. The thermosetting polymer, in comparison with thermosetting plastic, provides the sensor with a wider operating temperature range and high chemical resistance to aggressive liquids and their vapors such as isopropyl, benzene, toluene and ammonia. In addition, thermosetting polymer sensors have the longest service life in ethylene oxide sterilization processes.

Characteristic	Value
Active material	Thermosetting polymer
Substrate	Ceramic or silicon
Changing parameter	capacity
Measured parameter	% RH
measurement range	0 ... 100% RH
Accuracy	$\pm 1 \dots \pm 5\%$
Hysteresis	1.2%
Linearity	$\pm 1\%$
Response time	5 ... 60 seconds
Operating temperature range	-40 ... + 1850C
Temperature effect	-0.0022% RH / 0C
Long-term stability	$\pm 1\%$ RH / 5 years
Resistance to contamination	Excellent
Resistance to condensation	Excellent

During operation, water vapor penetrates through the upper porous capacitor plate (Fig. 5) and is balanced with the surrounding gas. At the same time, this coating protects the electrical processes that occur in the polymer layer from external physical effects (light and electromagnetic radiation). A polymer layer covering the porous platinum electrode from above protects the condenser from dust, dirt and oils. Such a powerful filtration system, on the one hand, provides the sensor with a long-term trouble-free operation under conditions of severe pollution of the environment, and on the other - reduces the response time.

The output signal of the humidity sensor is a function of temperature and humidity, therefore, to obtain a high measurement accuracy over a wide range of operating temperatures, a temperature compensation of the conversion characteristic is required. Compensation is especially necessary when the sensor is used in industrial equipment for measuring humidity and dew point (Figure 9.2).

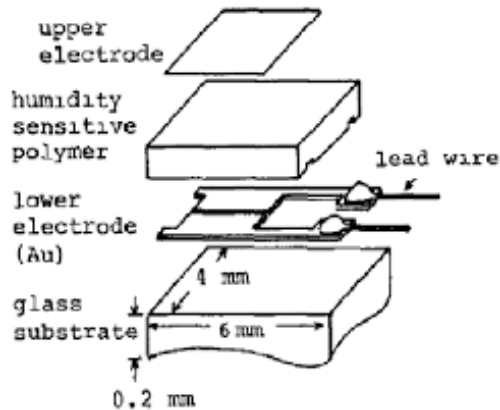

Fig. 9.2 - The multilayer structure method used in the manufacture of humidity sensors

Honeywell humidity sensors are integrated devices. In addition to the sensing element, a signal processing circuit is located on the same substrate, which provides signal conversion, amplification, and linearization. The output signal of the Honeywell sensor is a function of the supply voltage, ambient temperature and humidity. The higher the supply voltage, the greater the output signal amplitude and, correspondingly, the sensitivity. The connection between the measured humidity, true humidity and temperature is shown in the volumetric diagram (Figure 9.3).

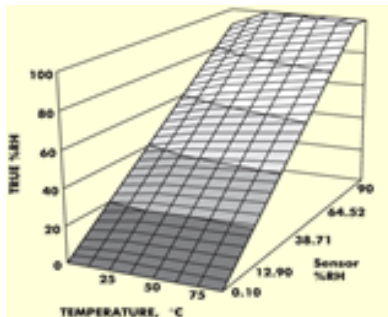

Fig. 9.3 - Relation between measured humidity, true humidity and temperature

It is easily approximated by a combination of two expressions:

1. The best fit line at 25 ° C (the thick line in the diagram) is described by the expression $U_{out} = U_{pt} (0.0062 \cdot (\% RH_{25}) + 0.16)$. From this equation, the percentage of RH25 at 25 ° C is determined.

2. Then the temperature correction is performed and the true value of RH is calculated: $RH_{true} = (\% RH_{25}) \cdot (1,0546 - 0,00216T)$, where T is measured in ° C. The expressions above correspond to the characteristics of real sensors with the following deviations:

$\pm 5,0\%$ – for $T < 10^{\circ}C$

$\pm 2,0\%$ – for $10^{\circ}C < T < 20^{\circ}C$

$\pm 1,0\%$ – for $T > 20^{\circ}C$

Models HIH-3602-L and HIH-3602-L-CP are made in a TO-39 body with a slotted hole. They offer an optimal price / reliability ratio. These sensors have found wide application in meteorological equipment and climate control systems.

9.2 Spray water flow sensor

The sensor DRK-4 is designed to measure the flow and volume of water in pipelines and has the following technical characteristics:

- 1) Measured medium - water with parameters:
 - temperature from 1 to 150 ° C;
 - pressure up to 2.5 MPa;
 - viscosity up to $2 \cdot 10^6$ m² / s
- 2) The diameter of the pipeline D_y 80 ... 4000 mm
 - 2) Dynamic range 1: 100
 - 4) Limits of measurement 2.7 ... 452 400 m³ / h
- 5) Output signals: current impulse (TI); Unified current 0 ... 5, 4 ... 20 mA;
- 6) Limit of the permissible relative error of volume and flow measurements on the pulse signal and the indicator:
 - $\pm 1.5\%$ at flow velocities of 0.5 ... 5 m / s;
 - $\pm 2.0\%$ at speeds of $0.1 \leq V < 0.5$; $5 < V \leq 10$ m / s.
- 7) Limit of permissible relative error of measurement
Operating time $\pm 0.1\%$;
- 8) 1 or 2 flow measurement channels;
- 9) Formation of an hourly archive of volume and flow values;
- 10) Self-diagnosis.

The principle of the action of the DRC-4 sensors is based on the correlation discrimination of the transit time by random, for example, turbulent fluctuations, the distance between two pairs of ultrasonic acoustic converters AP1-AP4, AP2-AP3. This is the time of transport lag and is a measure of the flow rate of the controlled medium moving through the pipeline. During operation, acoustic transducers (AP1-AP4), excited by ultrasonic frequency generators (GCHCH1 and GCHCH2), emit ultrasonic vibrations. These oscillations, passing through the flow of a liquid, generate secondary electrical oscillations on the AP. Because of the interaction of the opposing ultrasonic beams with the flow inhomogeneities due, for example, to the turbulence of this flow, the electric oscillations on the AP are modulated. These oscillations are fed to phase detectors (PD1 and FD2) and further to a correlation discriminator (CD) controlled by a microprocessor.

As a result of the correlation processing, the transport lag time is determined, according to which the microprocessor calculates the period of the output pulses and generates them. Further, the CD determines the amount of the cumulative total, the instantaneous consumption, the time of use and displays the information on the indicator. Output pulses of the converter. The DRC-4EP can be transmitted for additional processing to a heat calculator, integrator-counter or end-to-end converter DRC-4OP, which generates a unified current output signal 0 ... 5, 4 ... 20 mA proportional to the instantaneous flow rate.

Constructively, the sensor DRK-4 consists of a set of primary converters DRC \$ 4PP, electronic converter DRK-4EPHKH and terminal converter DRK-4OP. The set of primary converters consists of 4 acoustic transducers DRK-4AP with connecting cables of 3 m length and 4 chokes for mounting them on the pipeline. The controller of the display unit sums the input pulses, calculates the accumulated volume with cumulative total and instantaneous flow, outputs this information to the indicator, generates a binary code characterizing. The instantaneous consumption, which is entered in the DAC, forms the archive.

Main advantages:

- lack of flow resistance and pressure loss;
- possibility of mounting primary transmitters on the pipeline at any orientation with respect to its axis;

- Correction of indications taking into account inaccuracy of mounting of primary converters;
- preservation of information when the power is turned off for 10 years;
- Free-of-charge, imitating method of verification;
- Calibration interval - 4 years.

9.3. The executive mechanism

As the executive mechanism of the system being synthesized, the JVI minisprinkler 4191 is used, which is specially designed to maintain a constant humidity, reduce high temperatures in hot climates by evaporation and to irrigate plants under special conditions. Minisprinkler provides fogging with a very small droplet size - approximately 50 to 250 microns at a pressure of 3.0 Atm. The unique design eliminates the formation of large droplets and dripping on plants when placing sprinklers on top. Minisprinkler works in a wide range of water pressure. By raising the pressure and using sprinklers with a lower water flow, you can get the minimum droplet size. The minimum pressure at which the safety valve closes is approximately 2.5 Atm. Minisprinklery can be installed both on the racks, and suspended in the case of an upper water distribution.

Material	Polyacetate
Water flow rate	12,20,35,50,70,90,160,180 liters per hour
Operating pressure	1.0 ... 4.0 atm.
Irrigation diameter	2.0 ... 4.0 m
Angle of water flare opening	Circular, approx. 310 °

Direction of spraying	Horizontal / vertical
The size of the drops	50-150 crowns at a pressure of 3.0 atm.

9.4 The water level sensor in the ADZ-Floater Probe SML-PS1 "NAGANO" tank

Parameter name	Value
Pressure measuring ranges, bar	0-25
Output signal, mA	4-20
Connection diagram	Two-wire
Power, V	10-32
Temperature, ° C	+ 5 ... + 70
Measurement accuracy,%	0.5

9.5 Moisture Sensor Gardena

To account for soil moisture in automatic irrigation control. Durability and reliability of work due to thermoelectric measurement of the temperature difference in the soil. The required humidity is set by means of a rotating regulator. Indication of the actual moisture content of the soil. Equipped with a 5 m connecting cable with a plug.

9.6 Room temperature sensor for the greenhouse KTY81-210

Temperature sensors series KTY81-2 have a positive temperature coefficient of resistance and are well suited for measuring devices, as well as for monitoring and control systems. The sensors are placed in a special leaded plastic housing.

Specifications:

- the lower threshold of the measured temperature is -55 C;
- resistance corresponding to the lower threshold - 1980 Ohm (at 1 mA);
- the upper threshold of the measured temperature is 150 ° C;
- resistance corresponding to the upper threshold - 2020 Ohm (at 1 mA);

- maximum output current - 10 mA;
- temperature coefficient - 0,79;
- thermal time constant - 30 s in the open air;
- error - ± 3.02 C.

9.7 Tank temperature sensor in the reservoir numerix ETF01

Submersible temperature sensors are installed directly in the pipeline to measure the temperature of the water (or other coolant) in the heating, ventilation and air conditioning systems.

Length from 50 to 400 mm

The range of measured temperatures is -30 to +150 degrees

Sensitive elements: Pt100, Pt1000, Ni1000, Ni1000 TK5000, NTC 1.8K Ω , KTY81-210, NTC 10K, 20K, 30K, 50K and 10K Precon, LM235Z

Brass (ETF01) or steel sleeve (ETF02)

1/2-inch liner thread

Connection - a two-wire scheme (three-wire and four-wire versions - on request)

Measuring current - 1 mA

Terminal board - up to 1.5 square meters. Mm

Operating temperature - from -20 to +100 degrees Celsius

The case is plastic. Protection class - IP43

Snap-on cover

Dimensions 65 * 59 * 36 mm

9.8 Industrial controller Modicon 984 – 685

Industrial controllers from the Modicon 984 series are compatible with each other with wide functionality, each of which has its own set of tasks. Each system based on such a controller consists of a PLC (programmable logic controller, from an English PLC - Programmable Logic Controller) connected to the input and output modules. These modules, in turn, are connected to sensors and actuators. Based on the data received from them, the controller manages the production process. The input

modules convert the signals from the sensors into the kind required to process them in the CPU. Output modules receive signals from the CPU and convert to the voltage or current required to control the actuators.

The system memory of the 984 series controllers is based on CMOS (complementary metal-oxide semiconductor) technology with a backup battery to ensure the safety of information when the power is turned off. The controller uses two types of memory: ROM, for storing system information, and RAM, protected by a backup battery, to store the user program.

Peripheral devices, which include the host PC, can be connected directly to the 984 Series PLC via the integrated Modbus ports. Modbus is a communication protocol based on RS232, used to collect data, edit programs and load them into the PLC.

The industrial controller 984-685 is designed for building medium and large control systems. It supports up to 5 local 800i I / O modules and up to 31 remote I / O modules. To provide remote I / O, an additional S908 processor is required. The 984-685 PLC is equipped with two Modbus pores and one Modbus Plus port.

Table 9.2 - Technical Specifications of the Digital Input Module

TX AS-B825-016	
A type	24V Discrete Input
Active level	Tall
Number of inputs	16
Operating voltage	20 ... 28V
Number of input groups	1
Number of entries in a group	16
Maximum input voltage	
pulse	500V <3ms
Constant	30V
Flow current	

Nominal switching time	6 mA (24 V)
The weight	2.5 ms

Table 9.3 - Technical Specifications of the Digital Output Module

TX AS-B826-032	
A type	24V Digital Output
Active level	Tall
Number of inputs	32
Operating voltage	20 ... 28V
Number of input groups	1
Number of entries in a group	32
Output current	
Max. Per output	0.25 A
Max. Per group	8 A
Max. Per module	8 A
Flow current	0.1 mA (24 V)
Food	
+5 V	90mA
+4.3 V	1mA
5B	0mA
External power supply	24V, 600mA
Dimensions	
Place occupied	1 connector

The weight	1.16 kg
------------	---------

Table 9.4 - Technical Specifications of the Analog Input Module

TX AS-B872-200	
A type	C / A; 10V, $\pm 5V$, 0 ... 10V, 0 ... 5V
Number of channels	4
Input voltage range	-10 ... 10V, -5 ... 5V, 0 ... 5V, 0 ... 10V
Bit depth	12 Bit
Accuracy	0.1% at 25 ° C
	0.17% at 0-60 ° C
Linearity	0-60C, ± 1 LSB
Update frequency	<1ms all 4 channels
Food	
+5 V	750mA
+4.3 V	5mA
5B	0mA
Dimensions	
Place occupied	1 connector
The weight	1.4 kg

9.9 Console Pump K 200-150-250 / 4-5

The cantilever pump is, from the point of view of hydraulics, a characteristic type of the centrifugal pump, the working element of which is a centrifugal wheel. The centrifugal wheel consists of two disks, between which, connecting them into a

single structure, there are blades, smoothly bent in the direction, opposite to the direction of the rotation of the wheel.

When the wheel rotates, a centrifugal force acts directly on each wheel, directly proportional to the distance of the particle from the center of the wheel.

Under the action of this force, the liquid is ejected into the pressure pipe from the impeller, as a result of which a vacuum is created in the center of the wheel, and the peripheral part of it is pressurized.

The movement of the liquid through the suction line is due to the difference in pressure over the free surface of the liquid in the receiving tank and in the central region of the wheel where there is a vacuum.

In pumps of type K, the torque input from the motor shaft to the pump shaft occurs through an elastic coupling. In pumps of type KM, the impeller is mounted on the end of the elongated shaft of the motor.

The purpose and technical characteristics of the pump parts K and KM are identical, while the pumping units of the KM type have smaller overall dimensions and weight.

Engine specifications:

- engine power - 30 kW;
- nominal feed - 315 m³ / h;
- rotation speed - 1450 rpm;
- nominal head - 20 m.

10. Selection and description of the control loop

The diagram of the digital PID controller used is presented in the corresponding document (the block diagram is shown in Figure 10.1). Two signals are input to its input: the master signal, and the feedback signal, reduced to a conditional maximum of 5 V. To isolate the error, the OS signal is pre-inverted, after which it already goes to the adder. The error goes to three parallel connected amplifiers, responsible for working out the proportional, integral and differential gain factors.

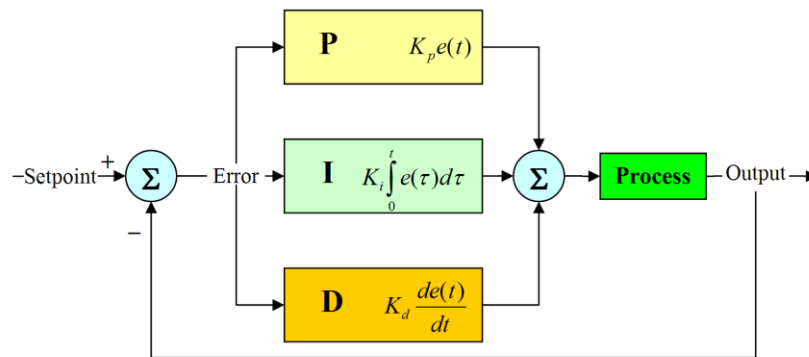

Figure 10.1 - Structural diagram of the digital PID controller

To implement the type of delay schemes, the decoupling shown in Figure 10.2 is used (the schemes correspond to the order of the transfer functions in the text). As a delay link, an integrated microcircuit is used, which allows to delay an analog signal, discrete, represented in a serial or parallel form. The chip also allows you to programmatically change the delay time.

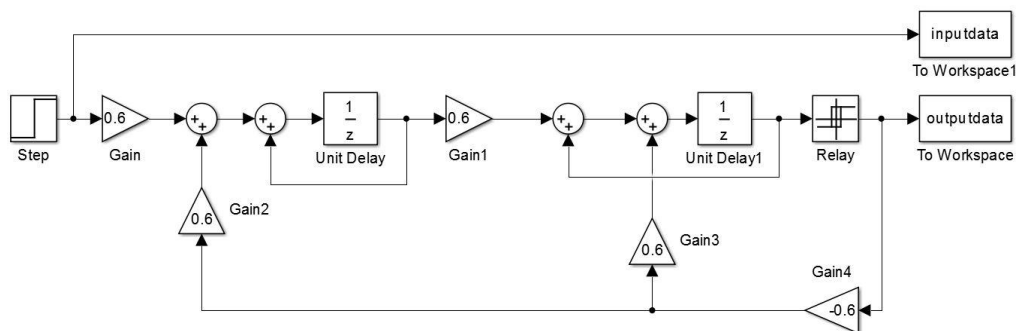

Figure 10.2 - Ways of implementing the transfer functions of the delay units

As you can see, the whole circuit is built on operational amplifiers (used to implement amplifiers, combiners and inverters), integrated delay microcircuits and resistors.

The circuit diagram also shows the remote control circuit for the electric drive of the regulating device (for example, an automatic valve, to disconnect pumps from the water supply network).

The circuit ensures the movement of the control devices only during the command signals. The limitation of the travel of the control devices in the end positions is provided by the corresponding limit switches.

In order to prevent the simultaneous activation of both coils of the reversing magnetic starter, in addition to the mechanical interlock that the starter is equipped with, an electrical interlock is provided in the circuit with the help of the NC block breakers PMO and PMO.

11. Calculation of the adjustment parameters of the control loop

Since the output of the transfer function of the three-phase motor is rather cumbersome, let us assume that DC motors are used in submersible pump wells. We calculate the parameters of the digital PID controller of such an engine. The DC motor as a dynamical system is described by the following equations in the operator form:

$$U_{\text{об}} = I_{\text{я}} \cdot R_{\text{я}} + E_{\text{я}} + L_{\text{я}} \cdot P \cdot I_{\text{я}}, \quad (11.1)$$

Where is $U_{\text{об}}$ the motor supply voltage;

$I_{\text{я}}$ - armature current;

$R_{\text{я}}$ - Active armature resistance;

$E_{\text{я}}$ - average value of the EMF of rotation;

$L_{\text{я}}$ - inductance of the motor windings;

P - engine power.

$$E_{\text{я}} = K_{\text{эм}} \cdot \omega, \quad (11.2)$$

$K_{\text{эм}}$ - coefficient, depending on the design parameters of the engine;

$\omega = 2 \cdot \pi \cdot f$ Is the rotational speed of the engine.

Expressions for the electromagnetic moment:

$$M = K_{\text{эм}} \cdot I_{\text{я}}, \quad (11.3)$$

$$M = M_c + J \cdot P \cdot \omega, \quad (11.4)$$

Where is M_c the external moment, or the moment of loading;

J - moment of inertia of the engine.

Based on these equations, a block diagram of the engine as a dynamic system can be constructed (Figure 11.1). The input signal for this system is the supply voltage, the

output signal is the rotational speed of the motor. Additional disturbance of the system is introduced by the external moment.

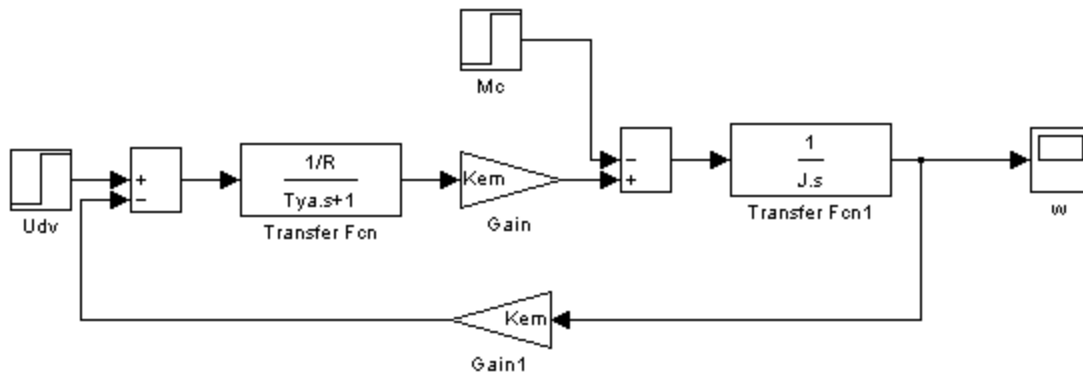

Figure 11.1 - Block diagram of the motor

From the block diagram it is possible to obtain the transfer functions of the motor relative to the rotational speed or current:

$$W_{\omega}(s) = \frac{\omega(s)}{U(s)} = \frac{K_{\delta\theta}}{T_M \cdot T_R \cdot s^2 + T_M \cdot s + 1}, \quad (11.5)$$

$$W_I(s) = \frac{I_R(s)}{U_{\delta\theta}(s)} = \frac{\frac{1}{R} \cdot T_M \cdot s}{T_M \cdot T_R \cdot s^2 + T_M \cdot s + 1}, \quad (11.6)$$

Where is $K_{\delta\theta} = \frac{1}{K_{\varepsilon M}}$ the transmission factor;

$$T_R = \frac{L_R}{R_R} \text{ - anchor time constant;}$$

T_M Electromechanical time constant.

Calculate the coefficients of the digital PID controller, controlling the starting or stopping of the DC motor with design parameters similar to those of the submersible pump motor (Table 11.1).

Table 11.1 - DC Motor Data Sheet

Characteristic	Value	Units Amend.
Rated power	30	KW
Rated voltage	380	AT
Rated current	85	A
Resistance of armature winding	30	Om
Inductance of armature winding	0,5	HH
Rotation frequency	152	Rad / s
Moment of inertia	0,3	Kg / cm2
Constructive parameter	2,5	Su
Em. Time constant	6,5	

The transition to the transfer function of the reduced continuous part of the engine is carried out according to the following formula:

$$W_{muy}(z) = \frac{z-1}{z} z \left\{ \frac{W_{muy}(s)}{s} \right\} \quad (11.7)$$

Where is $W_{muy}(s)$ the original transfer function of the motor.

Taking into account the technical characteristics of the engine, its transfer functions will take the form:

$$W_{muy}(s) = \frac{0,4}{0,1085 \cdot s^2 + 6,5 \cdot s + 1}, \quad (11.8)$$

$$W_{muy}(z) = \frac{0,0115 \cdot z + 0,001}{z^2 - 0,966 \cdot z + 0,06}$$

The transfer function of the digital PID controller is as follows:

$$W_{ню}(z) = Kp + \frac{Ku \cdot T \cdot (z+1)}{2 \cdot (z-1)} + \frac{Kd \cdot (z-1)}{T \cdot z}, (11.9)$$

Where is Kp the proportional component gain;

Ku - the gain of the integral component;

Kd - the gain of the differential component;

T - the sampling period (we assume 0.2 s).

The integral component is determined from the following relation:

Where is Kv the Q-factor with respect to speed (it is chosen arbitrarily in the range from 1 to 10. In this case we will take 1.2);

$W_{скор}(z) = W_{ню}(z) \cdot W_{нч}(z)$ - transfer function of the corrected system.

$$W_{нч}(z) \Big|_{z=1} = \frac{0,0115 + 0,001}{1 - 0,966 + 0,06} = 0,3997, (11.10)$$

$$Ku = \frac{Kv}{W_{нч}(z)} = \frac{1,2}{0,3997} = 3,0023. (11.11)$$

The remaining gain of the digital PID controller can be obtained from the following system of equations:

$$\begin{cases} \frac{Ku \cdot T^2 - 2 \cdot Kp \cdot T - 4 \cdot Kd}{2 \cdot Kp \cdot T + Ku \cdot T^2 + 2 \cdot Kd} = -B \\ \frac{2 \cdot Kd}{2 \cdot Kp \cdot T + Ku \cdot T^2 + 2 \cdot Kd} = C \end{cases}, (11.12)$$

Where B and C are coefficients selected from $W_{нч}(z)$.

This system, taking into account already known variables can be represented as:

$$\begin{cases} \frac{0,1201 - 0,4 \cdot K_p - 4 \cdot K_d}{0,1201 + 2 \cdot K_d + 0,4 \cdot K_p} = -0,9696 \\ \frac{2 \cdot K_d}{0,1201 + 2 \cdot K_d + 0,4 \cdot K_p} = 0,06 \end{cases}, (11.14)$$

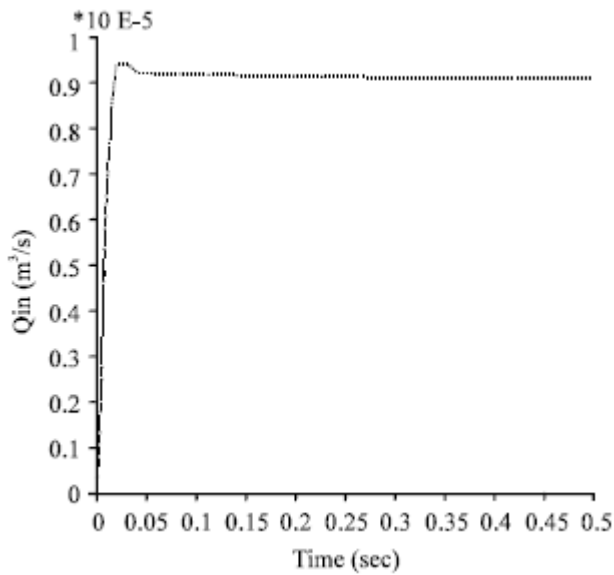

Figure 11.2 - Transient characteristics of the engine with and without regulator

Table 11.2 - Values of the coefficients of the digital PID controller

Coefficient	Designation	The calculated value.	Resulting value
Proportional	K_p	19,3852	19,3852
Integral	K_i	3,0023	0,30023
Differential	K_d	-0,56	-2,8

11.1 Calculation of the parameters of the circuit nodes

The block diagram of the digital PID controller contains at least three amplifiers (for implementing proportional, integral and differential gain factors), and two adders. A typical amplifier circuit is shown in Figure 11.2, the resistor resistances are in Table 11.2.

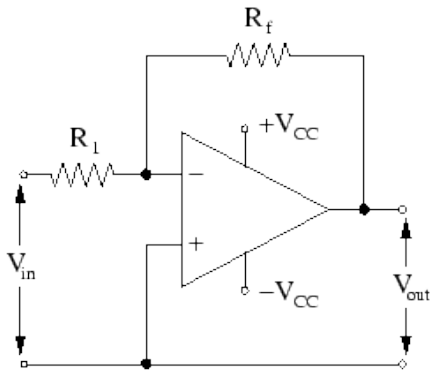

Figure 11.3 - Typical Amplifier Circuit

The gain can be calculated using the following formula:

$$K_{yc} = \frac{R_2}{R_1} \quad , \quad (11.15)$$

Here R_3 is used to reduce the drift of zero, and is assumed to be:

$$R_3 = \frac{R_1 \cdot R_2}{R_1 + R_2} \quad .(11.16)$$

Table 11.2 - Resistor Resistors Resistors

Element	Coefficient	Resistance (Kom)	In accordance with the series E192
R1	Kp	1	1
R2	Kp	19,3852	19,3
R3	Kp	0,95	0,96
R1	Ku	1	1

R2	Ku	0,3	0,301
R3	Ku	0,231	0,232
R1	Kd	1	1
R2	Kd	2,8	2,8
R3	Kd	0,736	0,732

A typical scheme of the adder is shown in Figure 11.4. Its output voltage can be calculated using the following formula:

$$U_{\text{вых}} = U_{\text{вх1}} \cdot \frac{R_{\text{oc}}}{R_1} + U_{\text{вх2}} \cdot \frac{R_{\text{oc}}}{R_2} + U_{\text{вх3}} \cdot \frac{R_{\text{oc}}}{R_3} \quad , (11.17)$$

If we assume that $R_1 = R_2 = R_3 = R_{\text{oc}}$, then we get:

$$U_{\text{вых}} = U_{\text{вх1}} + U_{\text{вх2}} + U_{\text{вх3}} \quad . (11.18)$$

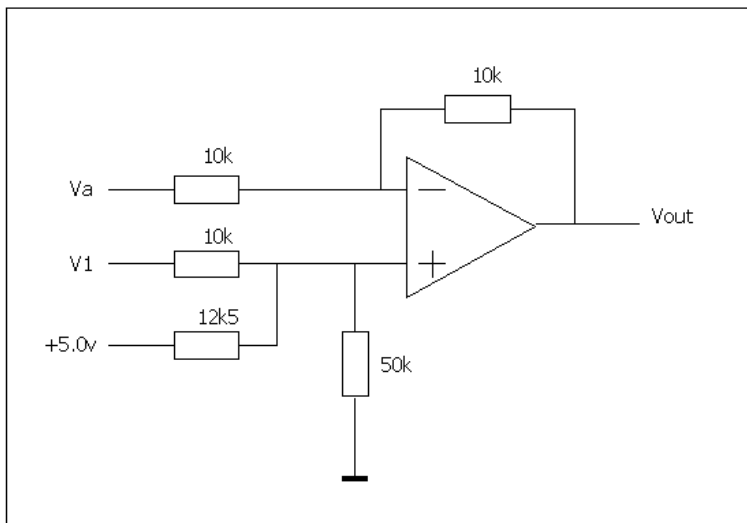

Figure 11.4 - Typical adder circuit

12. Development of workstation

Computer requirements are associated with a large volume of processed information and the need to present information graphically. LAN connects AWS operators and AWP main specialists (Chief Engineer, agronomist, head of the service).

By selecting the desired branch, the operator or another user of the system has the opportunity to switch to the monitoring mode. The operator switches to it after selecting the desired department.

The system message log is required for repeated system starts, when it is set up and set up. It allows you to monitor in real time the inclusion of sensors and other devices of the system, perform an analysis of device failures and their diagnostics. From the message log window, the user can print all system messages for a specified period of time.

The adjustment mode of the regulation system is used during commissioning, as well as during preventive maintenance by the service specialists. It allows you to take into account the technological features of specific actuators and set the necessary correction factors to improve the quality of regulation. The entrance to this window is available only for the company's specialists and for the customer's service.

Thus, the main advantages of the information and control complex ASUKK TX are:

A 15-20% decrease in heat and energy consumption;

Accuracy of maintaining the air temperature in the greenhouse $\pm 0,5$ ° C;

Maintenance of an optimum microclimate in a greenhouse and increase of possibility of influence on productivity of cultivated cultures;

High reliability;

The ability to conduct temperature and humidity measurements near control plants.

Thus, the main advantages of the information and control complex of ASUKK TX are:

A 15-20% decrease in heat and energy consumption;

Accuracy of maintaining the air temperature in the greenhouse ± 0.5 ° C;

Maintenance of an optimum microclimate in a greenhouse and increase of the opportunity of influence on the productivity of cultivated cultures;

High reliability;

The ability to conduct temperature and humidity measurements near control plants.

Conclusion

In this course project, a two-level automated process control system was synthesized that performs discrete regulation of air humidity and control of water consumption for spraying in a greenhouse. According to the preset parameters of the op-amp, the PI regulator settings were determined by simulation, which provides the necessary control accuracy and quality of the input influences (here - setting the humidity value). Using algorithms of primary processing, the influence of their parameters on the characteristics of the signal from the humidity sensor was investigated. Based on the condition of the error in the calculation of the control code, the densities of the DCU elements (ADC, DAC and ALU of the microcontroller) were calculated and a selection of a set of hardware was made.

13.Arduino

Arduino board designs use a variety of microprocessors and controllers. The boards are equipped with sets of digital and analog input/output (I/O) pins that may be interfaced to various expansion boards and other circuits. The boards feature serial communications interfaces, including Universal Serial Bus (USB) on some models, which are also used for loading programs from personal computers. The microcontrollers are typically programmed using a dialect of features from the programming languages C and C++. In addition to using traditional compiler toolchains, the Arduino project provides an integrated development environment (IDE) based on the Processing language project.

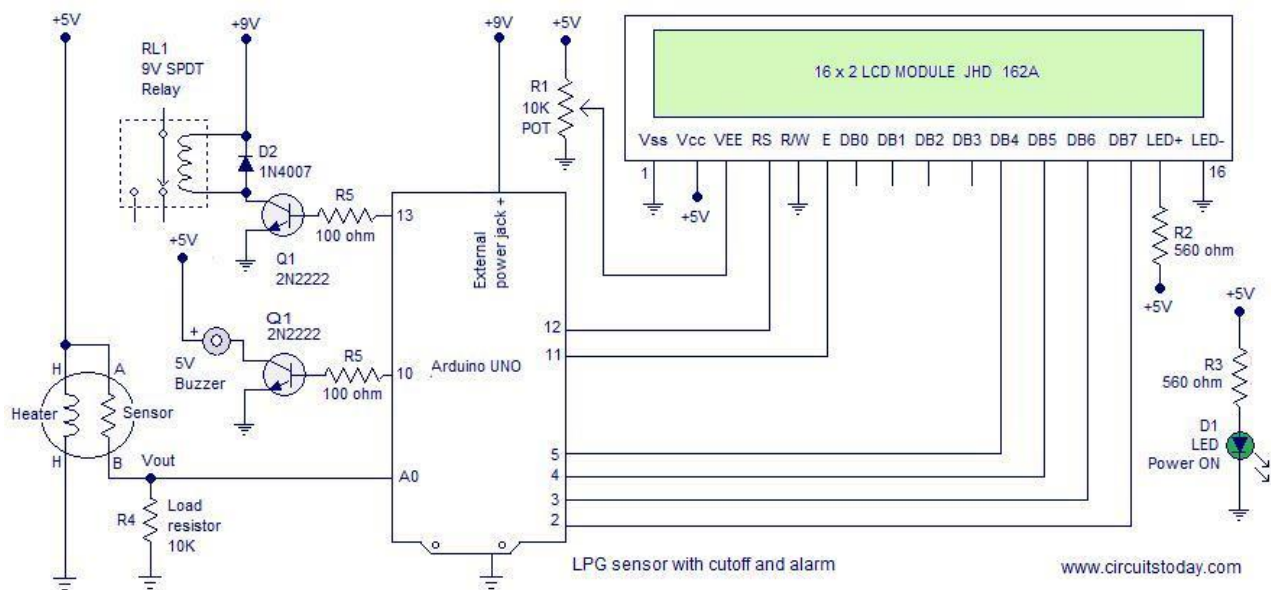
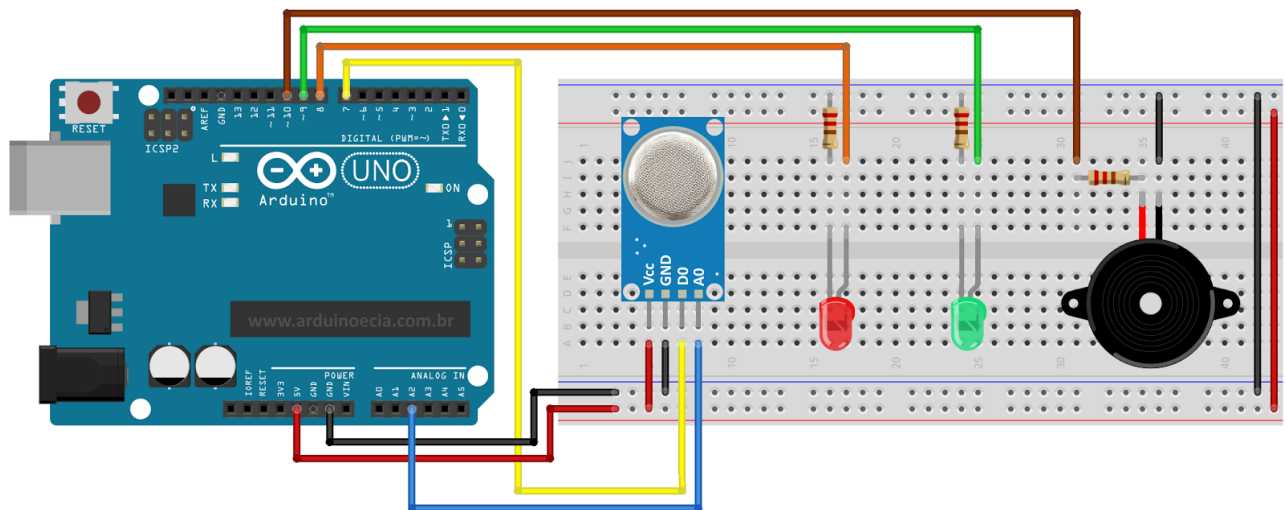

Arduino UNO:

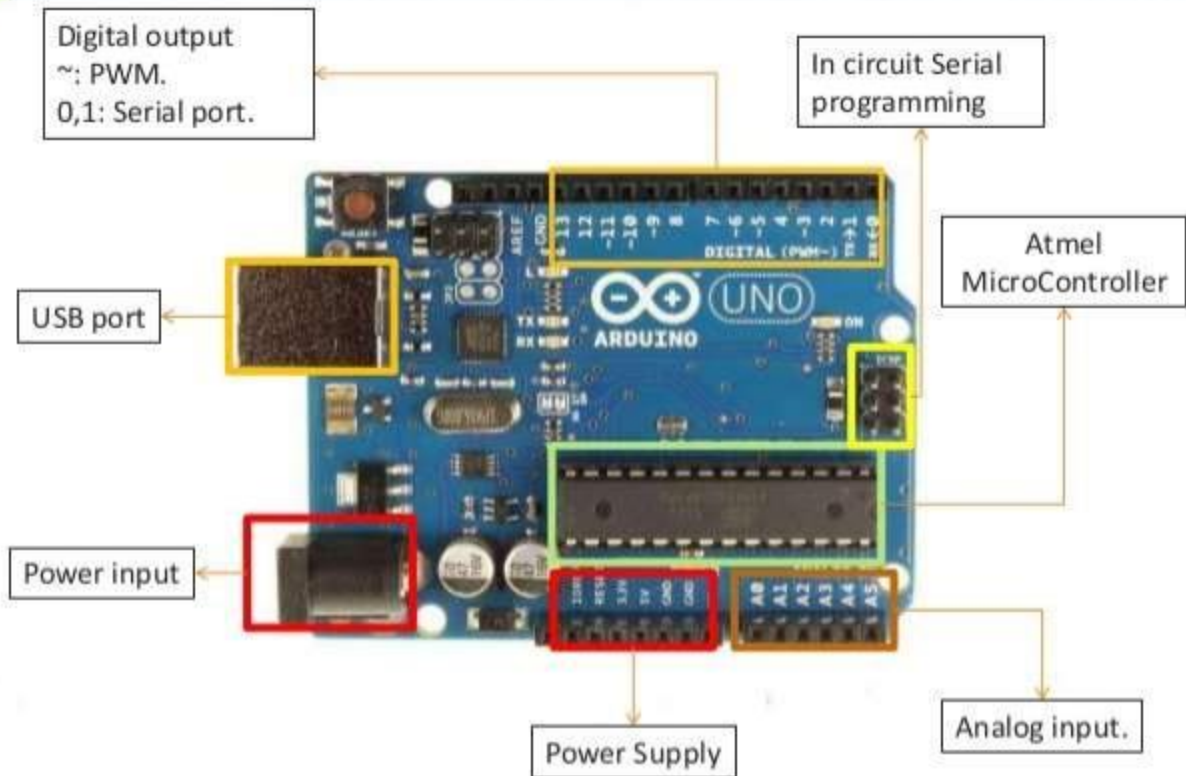

Practical section:

```
const int sensorPin= 0;
const int buzzerPin= 13;
int gas_level;
void setup() {
  Serial.begin(9600);
  pinMode(sensorPin, INPUT);
  pinMode(buzzerPin, OUTPUT);
}
```



```
void loop() {  
  gas_level= analogRead(sensorPin);  
  Serial.println(gas_level);  
  if(gas_level >250){  
    digitalWrite(buzzerPin, HIGH);  
  }  
  else{  
    digitalWrite(buzzerPin, LOW);  
  }  
}
```

List of literature

1. Sigrimis, N.; King, R. Special Issue on Advances in greenhouse environment control. *Comput. Electron. Agric.* 1999, 26, 217-374.
2. Narasimhan, L.V.; Arvind, A.; Bever, K. Greenhouse asset management using wireless sensor/actuator networks. In *Proceedings of IEEE International Conference on Mobile Ubiquitous Computing, Systems, Services and Technologies*, French Polynesia, Tahiti, 2007.
3. Gonda, L.; Cugnasca, C.E. A proposal of greenhouse control using wireless sensor networks. In *Proceedings of 4th World Congress Conference on Computers in Agriculture and Natural Resources*, Orlando, Florida, USA, 2006.
4. Zhu, Y.W.; Zhong, X.X.; Shi, J.F. The design of wireless sensor network system based on Zigbee technology for greenhouses. *J. Phys.* 2006, 48, 1195–1199.
5. Feng X.; Yu-Chu T.; Yanjun L.; Youxian S. Wireless Sensor/Actuator Network Design for Mobile Control Applications. *Sensors* 2007, 7, 2157-2173.
6. Sandee, J.H.; Heemels, W.P.M.H.; van den Bosch; P.P.J. Event-driven control as an opportunity in the multidisciplinary development of embedded controllers. In *Proceedings of the American Control Conference*, Portland, Oregon, USA, 2005.
7. Årzen, K.J. A simple event-based PID controller. In *Proceedings of 14th IFAC World Congress*, Beijing, China, 1999.
8. Åström, K.J. Analysis and Design of Nonlinear Control Systems. In *Event based control*; Astolfi, A., Marconi, L. Eds.; Springer: Berlin, Heidelberg, 2007.
9. Miskowicz, M. The event-triggered sampling optimization criterion for distributed networked monitoring and control systems. In *Proceedings of the IEEE International Conference on Industrial Technology*, Maribor, Slovenia, 2003.
10. Åström, K.J.; Wittenmark, B. *Computer controlled systems: Theory and design*. Prentice Hall: New Jersey, 1997.
11. Dormido, S.; Sánchez, J.; Kofman, E. Sampling, event-based control and communication (in Spanish). *Rev. Iber. Auto. Infor. Indu.* 2008, 5, 5–26. 16.

Rodríguez, F. Modeling and hierarchical control of greenhouse crop production (in Spanish). PhD thesis, University of Almería, Spain, 2002. <http://aer.ual.es/TesisPaco/TesisCompleta.pdf>.

12. Rodríguez, F.; Guzmán, J.L.; Berenguel, M.; Arahal, M.R. Adaptive hierarchical control of greenhouse crop production. *Int. J. Adap. Cont. Signal Process.* 2008, 22, 180–197.

13. Bot, G.P.A. Greenhouse climate from physical processes to a dynamic model. PhD thesis, Agricultural University of Wageningen: The Netherlands, 1983.

14. Kamp, P.G.H.; Timmerman, G.J. Computerized environmental control in greenhouses. A step by step approach. IPC Plant: The Netherlands, 1996.

15. Rodríguez, F; Berenguel, M.; Arahal, M.R. Feedforward controllers for greenhouse climate control based on physical models. In *Proceedings of the European Control Conference ECC01*, Oporto, Portugal, 2001.

16. Ellis, P. Extension of phase plane analysis to quantized systems. *IRE Trans. Automat. Control* 1959, 4, 43–54. 22. Xia, F.; Zhao; W. Flexible Time-Triggered Sampling in Smart Sensor-Based Wireless Control Systems. *Sensors* 2007, 7, 2548-2564. 23. Suh, Y.S. Send-On-Delta Sensor Data Transmission With A Linear Predictor. *Sensors* 2007, 7, 537-547.