

UDC 621.833

*V. B. ALGIN, S. A. GAVRILOV, N. N. ISHIN, N. N. MAKSIMCHENKO***SYNTHESIS, CALCULATION OF FUNCTIONAL PROPERTIES, RELIABILITY ASSESSMENT OF PLANETARY TRANSMISSIONS AND THEIR DIAGNOSTICS DURING OPERATION**

Developed models and computer methods cover the stages of synthesis, kinematic, quasi-static and dynamic calculations, prediction and monitoring the dependability of planetary transmissions. Method for constructing no isomorphic structures using canonical matrixes was developed, as well as a modular analytical method for obtaining a family of gearboxes based on a unified reliable core module. Under kinematic and quasi-static calculations, the transmission is represented by a kinematic diagram formed in an automated mode. Its equations are made by means of a structure-distributive matrix. The concept of a regular mechanical system provides a correct dynamic calculation of the transmission as a multibody system with variable states. In calculating transmission dependability, the principle of dependent behaviour of components in a loaded mechanical system is used. Variation in operation conditions is taken into account. The complex logic of limiting states is reproduced in a hierarchical system: constructional elements, parts, units, transmission. Monitoring the transmission dependability in operation is based on diagnostic models that link the vibration level and the degree of components damages. Diagnostic system analyses the vibroimpulses produced by gears. Some presented methods are used in state standards and at enterprises of Belarus.

**Keywords:** planetary transmissions, design models, reliability prediction, vibration diagnostics, vibration pulse, lifetime monitoring.*В. Б. АЛЬГИН, С. О. ГАВРИЛОВ, М. М. ИШИН, Н. М. МАКСИМЧЕНКО***СИНТЕЗ, РОЗРАХУНОК ФУНКЦІОНАЛЬНИХ ВЛАСТИВОСТЕЙ, ОЦІНКА НАДІЙНОСТІ ПЛАНЕТАРНИХ ПЕРЕДАЧ І ЇХ ДІАГНОСТИКА В ПРОЦЕСІ ЕКСПЛУАТАЦІЇ**

Розроблені моделі та комп'ютерні методи охоплюють етапи синтезу, кінематичні, квазістатичні і динамічні розрахунки, прогнозування і моніторинг надійності планетарних передач. Розроблено метод побудови ізоморфних структур з використанням канонічних матриць, а також модульний аналітичний метод отримання сімейства коробок передач на основі єдиного надійного базового модуля. При кінематичних і квазістатичних розрахунках трансмісія представлена кінематичною схемою, що сформована в автоматичному режимі. Її рівняння виробляються за допомогою структурно-розподільчої матриці. Поняття регулярної механічної системи забезпечує коректний динамічний розрахунок трансмісії як багаторівневої системи зі змінними станами. При розрахунку надійності трансмісії використовується принцип залежної поведінки компонентів у навантаженої механічної системі і враховується зміна умов експлуатації. Комплексна логіка граничних станів відтворюється в ієрархічній системі: конструктивні елементи, деталі, вузли, трансмісія. Моніторинг залишкового ресурсу передачі в роботі заснований на діагностичних моделях, які пов'язують рівень вібрації і ступінь пошкодження компонентів. Діагностична система аналізує віброімпульси, які є проявом в вібрації механізму ударних процесів, що виникають при переспряженні зубів. Ряд представлених методів використовується в державних стандартах і на підприємствах Білорусі.

**Ключові слова:** планетарні трансмісії, розрахункові моделі, прогнозування надійності, вібродіагностика, віброімпульс, моніторинг ресурсу.*В. Б. АЛЬГИН, С. А. ГАВРИЛОВ, Н. Н. ИШИН, Н. Н. МАКСИМЧЕНКО***СИНТЕЗ, РАСЧЕТ ФУНКЦИОНАЛЬНЫХ СВОЙСТВ, ОЦЕНКА НАДЕЖНОСТИ ПЛАНЕТАРНЫХ ПЕРЕДАЧ И ИХ ДИАГНОСТИКА В ПРОЦЕССЕ ЭКСПЛУАТАЦИИ**

Разработанные модели и компьютерные методы охватывают этапы синтеза, кинематические, квазистатические и динамические расчеты, прогнозирование и мониторинг надежности планетарных передач. Разработан метод построения изоморфных структур с использованием канонических матриц, а также модульный аналитический метод получения семейства коробок передач на основе единого надежного базового модуля. При кинематических и квазистатических расчетах трансмиссия представлена кинематической схемой, сформированной в автоматическом режиме. Ее уравнения производятся с помощью структурно-распределительной матрицы. Понятие регулярной механической системы обеспечивает корректный динамический расчет трансмиссии как многоуровневой системы с переменными состояниями. При расчете надежности трансмиссии используется принцип независимого поведения компонентов в нагруженной механической системе и учитывается изменение условий эксплуатации. Комплексная логика предельных состояний воспроизводится в иерархической системе: конструктивные элементы, детали, узлы, трансмиссия. Мониторинг остаточного ресурса передачи в работе основан на диагностических моделях, которые связывают уровень вибрации и степень повреждения компонентов. Диагностическая система анализирует виброимпульсы, которые являются проявлением в вибрации механизма ударных процессов, возникающих при пересопряжении зубьев. Ряд представленных методов используется в государственных стандартах и на предприятиях Беларуси.

**Ключевые слова:** планетарные трансмиссии, расчетные модели, прогнозирование надежности, вибродиагностика, виброимпульс, мониторинг ресурса.

**1. Introduction.** One of the modern trends in the synthesis of planetary transmissions is based on a complete computer search for possible structure variants [1]. The problem of transmission structure uniqueness (or isomorphism) significantly complicates the synthesis procedure, since many externally different variants of solutions describing the same structure (diagram) are involved in the process. In a number of works, this problem is solved with the use of graphs to describe the structure of planetary transmissions [2–4]. However, all these works suppose the construction of possible variants, and then the recognition of isomorphic solutions. In the paper, this problem is solved by means of forming the unique (non-isomorphic) structures in the process of constructing. The

second direction in the synthesis of planetary transmissions is the use of basic modules, for example, the mechanisms of Ravigneaux, Simpson and Lepelletier [5]. Under this direction, the article presents a method for synthesizing multistage transmissions based on the modified Simpson mechanism.

In the field of *kinematic, quasi-static and dynamic calculations* of mechanical systems, well-known software packages that have wide universality are used [6–8]. This entails the cumbersomeness and complexity of their application to special objects, similar to the transmission, for which the initial and main form of representation is the kinematic diagram (scheme). In a number of packages for the design of drives, the representation of the transmission is

© V. B. Algin, S. A. Gavrilo, N. N. Ishin, N. N. Maksimchenko, 2018

limited to reducers [9, 10]. Complex kinematic and other diagrams that combine gears of various types are not modeled. Special calculations for such facilities are not foreseen. Thus, there are no convenient tools for operations with basic representations of the transmission in the form of kinematic and dynamic diagrams (schemes). The development of such tools is one of the tasks considered in the article.

In predicting the *reliability of systems*, structural methods dominate. It is assumed [11, 12], that the prediction of system reliability is based on reliability data of components. However, the problem consists in how to obtain mentioned data. The same mechanical component, for example, a bearing or a gear, has different lifetime in different units and machines. Hähnel et al. [13] mark dissociation of structural and engineering approaches. The first one is named as "system without physics", and the second one as "physical without system". Next problem of the correct reliability calculation consists in random character of initial data for operation conditions of machines and characteristics of load-carrying abilities of components. This aspect is treated as uncertainty of the initial information. The Monte Carlo method is used for passing casually chosen physical variables through fault tree of system with complex failure logic and for determining possible consequences [13]. However, the description and taking into account the dependences for components in this reliability calculation is not considered in an explicit form. In [14], degradation of dependent components is examined. It is pointed out that the degradation of one component may influence the degradation of the other component, as they are operated under the same environment and can be functionally related. Dependencies among the degradation processes of the components should be taken into account during the dynamic reliability assessment and prognostics process. The approach used by Lin and Zio [14] is based only on mathematical modelling without involving physical (mechanical) models of degradation and reproducing the common factors causing degradation processes. The simplest case, in which the dependent behaviour of components is taken into account in a frame of the mechanical model, is the consideration of the reliability of a mechanical chain as a system consisting of several identical links under the action of breaking load [15]. But this way is not admissible for the transmission containing many diverse components. Therefore, one of the problems considered below is the calculation of transmission reliability as a system of various loaded components.

The working process of the transmission is usually accompanied by oscillations and vibrations. Therefore, *vibroacoustic* plays an important role. Most of the diagnostic methods developed and standard tools are effective in diagnosing machine units operating in quasi-stationary conditions. These are various gearboxes of the technological equipment and aircrafts, test and running-in stands, fans, turbines, compressors, pumps, etc. Typical publications on that subject, containing approaches and tools for diagnosing gear systems, are [16–18]. Transmission systems of cars and tractors operate under conditions of varying speeds and loads. Under such conditions, the nature of vibrations (amplitude and frequency composition) is constantly changing. The well-known equipment and techniques are not suitable for vibration monitoring of the technical state of the transmission components. Approach-

es that combine computing models of working processes and sensors data that provide information on the progress of these processes in a particular product are most effective for predicting individual reliability.

**The paper objective** is to present the complex of models and methods for designing and monitoring the operation of vehicles planetary transmissions developed at Joint Institute of Mechanical Engineering of NASB taking into account methodology of Industry 4.0 (i4.0).

Paper includes: questions of synthesis of planetary transmissions (Section 2), their kinematic, quasi-static and dynamic calculations (Section 3), predicting dependability (Section 4), monitoring dependability in operation (Section 5), and Conclusions (Section 6).

## 2. Synthesis of planetary transmission.

*2.1 Synthesis of non-isomorphic structures.* Known approaches suggest the construction of all possible variants of structures, and then the selection of non-isomorphic ones. The proposed approach is based on the construction of obviously non-isomorphic structures. The structure is described by a canonical matrix, formed under the special rules, which makes it possible to avoid isomorphism.

The mechanism ( $U_j, j = 1 \dots N_D$ ) having three parts (links) ( $V_i, i = k, l, m$ ) and two degree of freedom ( $W = 2$ ) is a basic element of transmission structure, where  $N_D$  is a general number of three-part transmission mechanisms. Part  $V_i$  can enter into  $k$  mechanisms. The number  $k$  is parameter named as part degree ( $\text{deg}V_i$ ). All variants of distribution  $\text{deg}V_i$  for parts are created beforehand. This is not a problem.

The structure is shaped by means of parts junction by the resolved modes. When structures are constructed, the incidence matrixes are used as well as a set of rules which allow receiving only original (non-isomorphic) structures. Principal rule is "use for each mechanism parts with the smallest numbers". An additional rule is "use of all various variants of selecting parts taking into account their entrance in certain number of mechanisms". Besides, conditions of existence and workability for the mechanism are checked. These are: 1) integrity, and 2) lack of interlocking. Incidence matrixes generated by such a way are named "canonical matrixes". A detailed description of the procedure is given in [19].

The procedure can be implemented 'manually'. This is its peculiarity. Computer version is also implemented. Fig. 1 shows fragments of computer synthesis for structures with  $W = 3$  and  $N_D = 4$ . Variants of the  $\text{deg}V_i$  distribution by links are on the left, and a fragment of variants of constructing canonical matrices for distribution 2 (variant 1) and 3 (variants 2 and 3) are on the right.

*2.2 Synthesis of transmissions based on modified Simpson mechanism.* The developed synthesis procedure refers to transmissions consisting of two modules: the main gearbox (MG) and an additional (range) reducer (AR). The MG contains a basic mechanism (BM) in the form of a modified Simpson mechanism, and the attached mechanism (AM). Simpson mechanism has a high load-bearing capacity due to the distribution of the input power flow among several parallel branches and the summation of these flows on the output shaft. MG, containing such a mechanism, can be placed not only at the output, but also at the input to the transmission, ensuring a sufficiently uniform loading for the planetary gear sets of MG and AR.

Distribution 1	4 3 1 1 1 1 1			
Distribution 2	4 2 2 1 1 1 1	Variant 1	Variant 2	Variant 3
Distribution 3	3 3 2 1 1 1 1	1 1 0 1 0 0 0	1 1 1 0 0 0 0	1 1 1 0 0 0 0
Distribution 4	3 2 2 2 1 1 1	1 1 0 0 1 0 0	1 1 0 1 0 0 0	1 1 0 1 0 0 0
Distribution 5	2 2 2 2 1 1	1 0 1 0 0 1 0	1 0 1 0 1 0 0	1 1 0 0 1 0 0
		2 2 2 2 1 1	0 1 0 0 0 1 1	0 0 1 0 0 1 1

Fig. 1 – Fragments of computer synthesis:  $degV_i$  distribution (left) and canonical matrices (right)

The block diagram of the transmission is shown in Fig. 2. In the first execution case (input element 7, output element 8), the MG has three drive-down gears. In the second execution case (input element 8, output element 7), MG has three overdrive gears. To form the MG, the AM having  $W = 2$  is added to the links 33 and 9 of the BM. The characteristic result of the synthesis of the transmission is shown in Fig. 3, and the gear ratios are shown in Table 1.

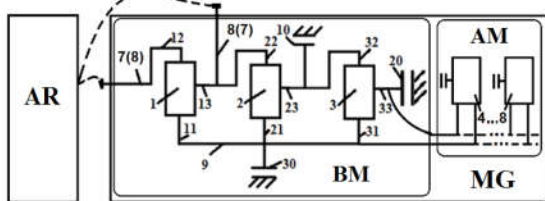

Fig. 2 – Transmission block diagram

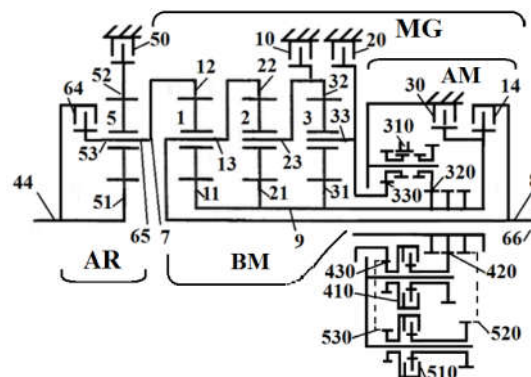

Fig. 3 – One of the synthesized transmission

Table 1 – Transmission gear ratios

Clutch / brake of AR	Clutch / brake of BG						
	10	20	30	14	320	330	310
64	11.53	8.700	6.554	4.973	3.825	2.942	-9.597
50	2.318	1.749	1.318	1.000	0.769	0.592	-1.930

**3. Transmission kinematic, quasi-static and dynamic calculations.**

3.1 Kinematic and quasi-static calculations based on symbolical representation devices and structurally-distributive matrix. Transmission devices, which have the same mathematical structure and differ only in param-

eters, can be represented in a generalized (symbolic) form (Fig. 4). To describe the structure and distribution of the internal torques in devices, a structurally-distributive matrix (SDM) is introduced. Each mentioned device is presented at such a matrix in the form of a column, as it is shown in the Table 2.

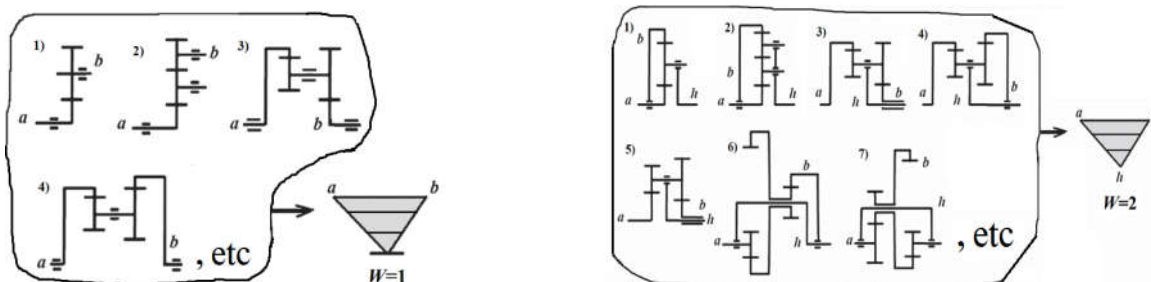

Fig. 4 – Symbolic representation of typical transmission devices: gears (left) and differentials (right)

Table 2 – Devices representation and distribution of internal torques among parts of devices

Basic part of devices	Differential <i>D</i>	Train <i>P</i>	Shaft <i>S</i>	Frame <i>R</i>	Clutch <i>F</i>	Brake <i>T</i>
1 ( <i>i</i> )	1	1	1	1	1	1
2 ( <i>j</i> )	- <i>u</i>	- <i>u</i>	-1 ( <i>u</i> =1)	0 ( <i>u</i> =0)	-1	0
3 ( <i>k</i> )	-(1- <i>u</i> )	—	—	—	—	—

The meanings of non-zero elements of *k*<sup>th</sup> column ( $A_n = A_{jk}$ ) describe the distribution of torques in the kinematic unit ( $A_n = M_n/M_1$ ). After describing the structure of the transmission using SDM, the equations for its kinematic and quasi-static calculations are automatically formed. As a result, the speed of the links, the torque in the devices and the efficiency for each transmission gear are determined [19]. In the latter case, the kinematic gear ratio  $u_i$  is replaced by the power gear ratio  $u_i = u_i \eta_{0i}^x$  for each device, where *x* is equal +1 or -1, depending on a direction of power in the device.

**3.2 Concept of regular mechanical system. Dynamic computing.** A mechanical system with elementary mechanical components (the concentrated masses and the massless joining links) is essential idealization which imposes certain restrictions on possible combinations of joints (connections) for mentioned items.

The concept of regular mechanical system (RMS) considers that mechanical system consists of the concentrated masses (inertial components) and massless (non-inertial) devices-connectors: shafts, clutches, brakes, gears, motionless links, and other devices imposing kinematic connections for masses (Fig. 5). Masses can be in contact interaction. For connecting device, the direct contact (not through inertial component) is prohibited. This is a principle of regularity, which is used for the representation of a real object. Its violation leads to wrong schematizations and errors in calculations or impossibility of mathematical model realization by the computer [19].

Clutches and brakes are the typical devices having variables states (Fig. 6). For getting all-purpose mathematical model for their dynamics, a method of internal torques is used. This one is based on logical variables  $\lambda_k$ , named indicators states, which describe states of clutches/brakes.

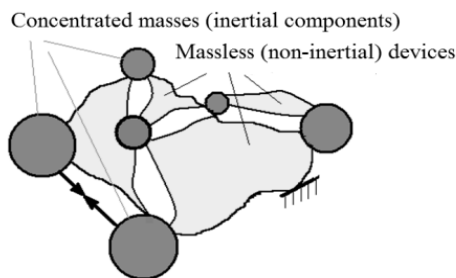

Fig. 5 – General representation of RMS

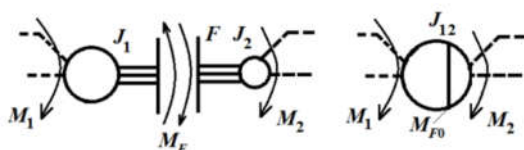

Fig. 6 – States of a friction clutch: slipping (left) and locking (right)

The equations corresponding to the clutches are as follows:

$$\dot{\omega}_1 = [M_1 - (1 - \lambda_F)M_F - \lambda_F M_{12}] / J_1; \quad (1)$$

$$\dot{\omega}_2 = [(1 - \lambda_F)M_F - \lambda_F M_{12} - M_2] / J_2, \quad (2)$$

where  $\lambda_F = 0$  under locking, and  $\lambda_F = 1$  under slippage (unlocking) of the clutch;

$M_F$  is the known function describing a friction torque during slipping friction clutch parts.

In order to use all-purpose equations a special procedure should be developed for finding the internal torques (like  $M_{12}$ ) which acting in rigid devices. Besides, conditions of change for friction clutches states should be described during the solving the differential equations. In a case under review the internal torque can be calculated by formula

$$M_{12} = (J_2 M_1 + J_1 M_2) / (J_1 + J_2). \quad (3)$$

Generally, it is necessary to consider spasmodic change of a friction torque at transition from slippage to friction clutch locking and inversely.

Generalization of these situations for computing leads to the formulation of following principle: if a new condition of contacting inertial parts (for example, slippage or locking of friction clutch/brake) becomes possible then this condition should be necessarily presented at next step of computing process [19].

In general case the RMS can be stiff-elastic object that contains rigid and elastic devices. As typical example, RMS with rigid and elastic devices is presented in Fig. 7. Dynamic diagrams related to this RMS are shown in Fig. 8. During computing stiff-elastic object, it is necessary to solve a system of differential equations, and this is accompanied by solution of a system of algebraic equations to determine the internal torques in rigid devices.

To avoid solving algebraic equations, the dynamical system can be normalized by replacing rigid devices with elastic ones having elasticities  $E_i > 0$  (see Fig. 8, for brakes external links like  $E_{22}$  may be rigid). In the normalized system, masses and elastic links alternate. To determine the internal torques of closed clutches/brakes, a simple formula (3) is used instead of solving the system of algebraic equations. This approach simplifies forming mathematical models but increases a number of differential equations.

**4. Transmission dependability assessment.** The general approach reproduces the probabilistic nature of components properties and effects of their dependent behaviour in a system. This approach [19] has universal character and it can be applied to any technically complicated item, like a transmission.

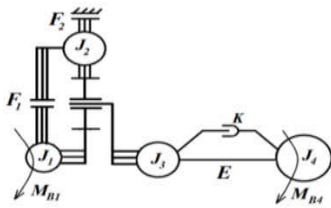

Fig. 7 – Stiff-elastic RMS

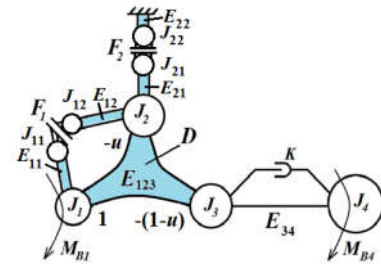
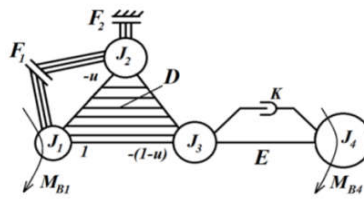

Fig. 8 – Stiff-elastic (left) and normalized (right) diagrams

Load modes are various for different machine parts. But all load modes are determined by the operation conditions. Therefore, the operation conditions are described by probabilistic manner in a form of the relative durations for the commonly accepted typical conditions (Fig. 9, left).

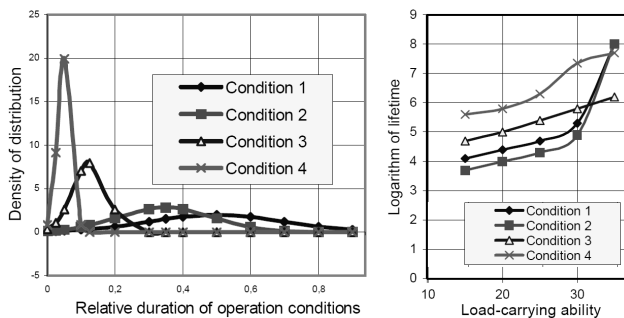

Fig. 9 – Representation of operation conditions (left) and lifetime-strength curves of a component (right)

To rate the loaded systems in the general case, the calculation can be performed under the scheme "operation conditions – lifetime". For this purpose, lifetime-strength curves are introduced (see Fig. 9, right). These curves are preliminary calculated for every component by methods of mechanics.

The limiting state of a complex item is usually determined by a complicated way, based on combination of limiting states of its components. To describe and calculate such states, the scheme of limiting states (SLS) can be used. It describes the limiting states of a complex item much easier than the known tools (Failure tree and Reliability block diagram). In addition, SLS is convenient for use in statistical modelling procedures, where it is presented in the form of simple records. The SLS consists of a hierarchical structural scheme and records describing limiting states for every scheme object (except lowest object). The objects of the lower and intermediate levels are endowed with the type: the first type, the second type, and so on. Objects whose limiting states have the same significance for an object of a higher level are classed as the same type. The object type corresponds to its position (first, second, etc.) in the schematic record, which describes the criterion of the limiting state.

The record (X1, X2, X3, etc.) means that the limiting state of the machine (assembly, unit ...) occurs if the limiting states are reached with its X1 parts of the first type (here X1 is the number standing in the first position), its X2 parts of the second type (here X2 is the number standing in the second position), etc. The unit, assembly, machine can have some the SLS. For example, a mechanical

gearbox (Fig. 10) has the following SLS: (1,0,0,0) (0,3,0,0) (0,0,1,2).

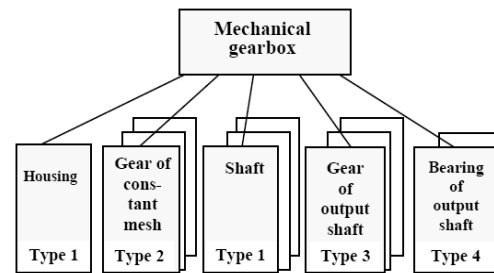

Fig. 10 – SLS of the mechanical gearbox

In the general case, there is a multilevel SLS that reproduces the following levels: 1 = the machine (for example, a car); 2 = aggregates and systems (e.g. transmission, carrier system); 3 = units and subsystems (e.g. gearbox, drive axle); 4 = parts (e.g. gear), typical component parts (e.g. ball bearing), joints (e.g. splined connection); 5 = constructional elements (e.g. gear teeth); 6 = the simplest components (e.g. local area of the surface layer of the gear teeth). Mechanics methods are used for calculations of limiting states at levels 6, 5, and 4 (in some cases), and structural ones are used at levels (from 4 or 5 to 1).

The life cycle forecasting is based on the Monte Carlo method that has the following features. The relative durations of operation conditions and the load-carrying ability of elements are considered as the random variables. They are randomly selected in the process of statistical modelling and describe the concrete item and its operation condition. Every simulation cycle is supplemented by the SLS analysis and lifetime determination for objects of higher levels. When reproducing processes and states related to mechanical levels, factors and effects leading to dependent behaviours of the mechanical components are realized, for example, the general loading levels of components in the particular transmission device.

**5. Diagnostics of planetary transmission in operation.** The main feature of the developed diagnostic method is using conceptual modelling the oscillating process for the gear drive and the propagation of vibrations in the transmission. It is advisable to applicate together integral diagnostic models and predictive ones based on damage accumulation. Such a "two-coordinate" approach ensures a higher veracity of the individual lifetime forecast. The method is demonstrated with the example for a reducer of a motor-wheel of a mining dump truck [20].

5.1 System for vibrodiagnostics of the RMW. The reducer of a motor-wheel (RMW) with installed sensors is shown in Fig. 11.

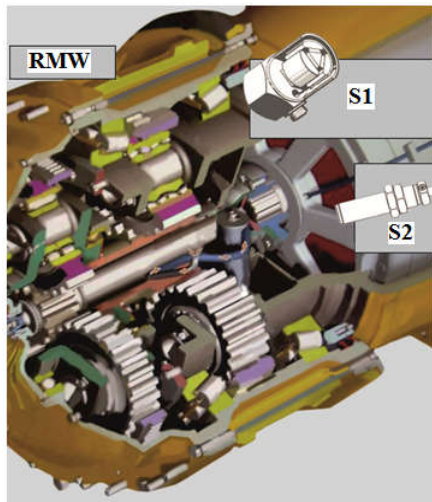

Fig. 11 – RMW with sensors

Two different types of sensors are used to diagnose RMW. The first sensor S1 is an accelerometer that senses the vibration of the housing. The second sensor S2 transmits data on the speed of the gearbox shaft. The main processes for the emergence, transformation and processing of signals in the RMC and its monitoring system are shown in Fig. 12.

The signal S1 is the result of the propagation of a shock pulse along the mechanical transmission paths. It manifests itself in the vibration spectrum of the motor-wheel housing.

Vibrodiagnostics problems associated with the non-uniformity of rotation of the gears, solved by using the developed algorithms for processing the vibration signal

and the signal of the rev counter recorded in real time. As a result, the temporal realization of the vibration signal is converted into a realization by the angle of the shaft rotation for the diagnosed gear. Analysis of this implementation using the method of synchronous accumulation and ordinal analysis, adapted to the solution of a particular task, allows us to estimate the vibration parameters of each reducer gear (Fig. 13). The spectra clearly show peaks at frequencies of 21, 42, 63, 84 Hz, multiples of the tooth frequency of the sun gear that has 21 teeth. A similar view has a spectrum for satellites that have 47 teeth.

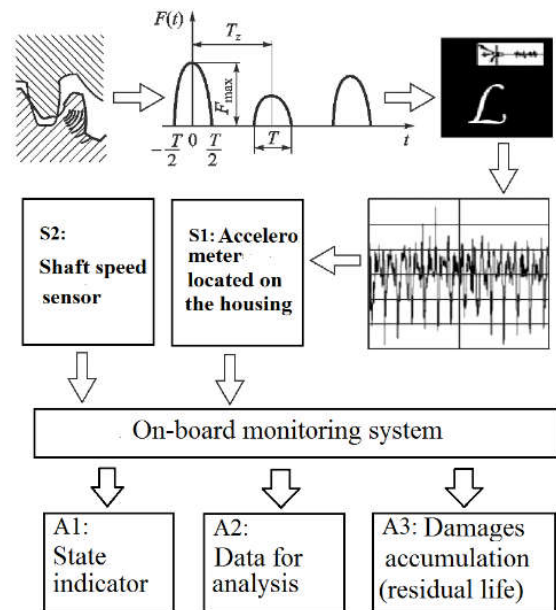

Fig. 12 – Processes in the RMW monitoring system

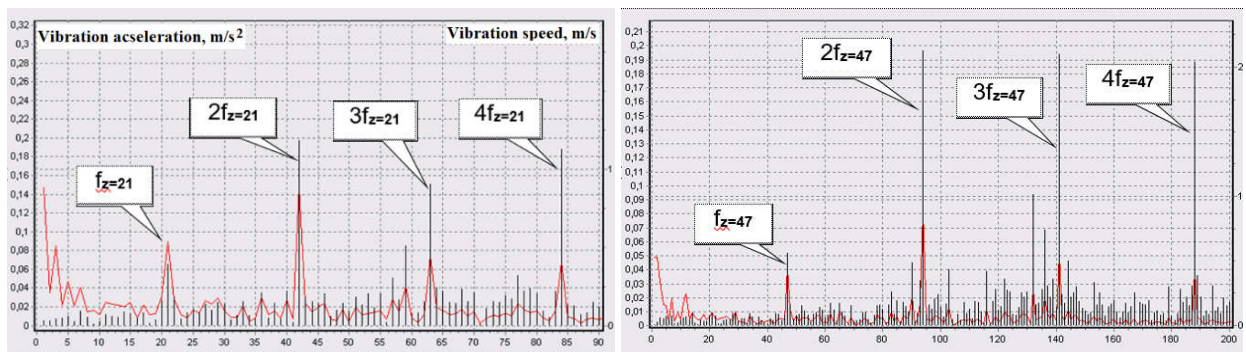

Fig. 13 – Harmonic spectra of vibrations generated by the sun gear (left, 21 teeth) and satellites (right, 47 teeth) of the RMW planetary row

5.2 Indicators of the technical state of the gears. The mean square value and the mean amplitude of the first seven harmonics for the tooth frequency are adopted as indicators of the technical state of the gears. The operation of the system (see Fig. 12, block A1) includes: 1) analysis of the parameters for vibroimpulses synchronized with the angle of rotation of the diagnosed tooth gear; 2) identification of vibroimpulse harmonic components, which multiple of the tooth frequency, locate in the region of resonance frequencies of the mechanism and excite the most

intense oscillations in the system; 3) determination of the technical state of gears under variable load-speed regimes through analysing the changing the parameters of vibroimpulses.

5.3 Integral assessment of the state. The diagnostic system periodically interrogates the sensors, processes the diagnostic information, evaluates the technical state of the reducer, comparing the received root mean square (RMS) values of vibration acceleration with the maximum permissible values for each of the states of the reducer. The

system constantly informs the driver by means of an appropriate light signal on the instrument panel in the cab of the truck.

The system constantly informs the driver by means of an appropriate light signal on the instrument panel in the cab of the truck:

– green = vibration parameters of the reducer (VPR) are within the permissible values. There are not restrictions for operation;

– yellow = VPR periodically go beyond the allowed values. In this case, the operation of the machine continues, the specialists carry out an in-depth analysis of the vibrations of the RMW with the determination of the defective element and the forecast of its residual life (blocks A2 and A3);

– red = VPR are outside the allowed values. An emergency failure of the reducer (and machine) is possible. The machine must be sent for repair.

Actions, marked in Fig. 12 as blocks A2 and A3, are carried out by the service department with the help of special software.

They include the following operations:

– transfer of stored data files from the on-board system memory to a stationary computer;

– obtaining harmonic spectra of vibrations of each gear of the reducer by means of synchronous accumulation algorithms and ordinal analysis (see Fig. 6);

– analysis of spectra and identification of gears generating high levels of vibration;

– for the teeth of gears with high vibration levels, the operating load and contact stresses are determined using the parameters of the vibroimpulses. Then, taking into account the loading cycles, the residual life is calculated according to the developed technique [20].

After that, a decision is made to continue the operation of the reducer or opening it to eliminate the causes of increased vibration (adjustment, tightening of connections, topping up oil, etc.). Based on the results of the opening, a decision is made to repair or further operate the truck.

#### 5.4 Forecasting the lifetime expense

The method of forecasting the lifetime expense (consumption) of the responsible elements of the drive mechanisms of machines under operation conditions is based on the determination of the shock pulse in a meshing according to the results of vibration monitoring. Then a discrete spectrum of oscillations of a periodically acting shock pulse is formed, and, accordingly, a set of harmonic oscillations determining the load in the meshing. From these data, the actual circumferential force and contact stresses in the meshing are calculated. The lifetime expense of the gear is determined for each fixed  $i$ -th interval of the running time  $\Delta S_i$  by the formula

$$\Delta Q = \sigma_{H_i}^{q_H} N_i, \quad (4)$$

where  $\sigma_{H_i}$  – contact stress;

$q_H$  – the exponent of the fatigue curve under calculating the gear for the contact endurance;

$N_i$  – the number of loading cycles of the gear tooth.

5.5 Application example. Estimating the state of the gearing "sun gear/satellite" of the second planetary row of RMW is presented.

When the technical state is evaluated via integral assessment, the change in RMS values of the vibrational acceleration is monitored. The change in this indicator is shown in Fig. 14. When the dump truck mileage is less 200,000 km, this value remains practically constant. Further it increases, at the same time the peak value of vibration acceleration begins to increase.

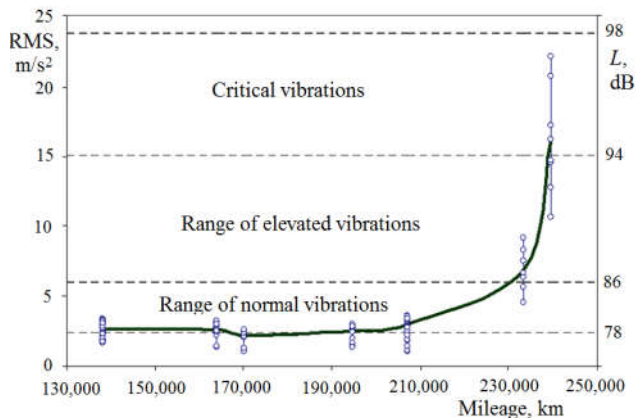

Fig. 14 – Dependence of RMS values of vibration acceleration of RMW on the mileage of a dump truck

When lifetime expense is calculated using the diagnostics current data, it is taken into account that a linear relationship exists between the amplitude of the shock pulse and the peak value of the vibration acceleration. The growth of peak values means an increase in the dynamic factor  $K_{Hv}$ , which is used in the calculation of contact stresses  $\sigma_H$ .

The calculation performed for the most probable value of the load-carrying ability of the considered gears gave a result similar to the integral assessment. Residual life is equal to zero under the general dump truck mileage equal to 235,000 km (taking into account the descent movement in the open-cast mine and the transportation mode).

With a mileage of 238,100 km, the operation of the dump truck was stopped, as the vibration monitoring system showed that the vibration level of the reducer reached the critical range. Reducer disassembly confirmed the result of the calculation and the data of the monitoring system. The reinforced layers of four teeth of sun gear were almost completely destroyed (Fig. 15).

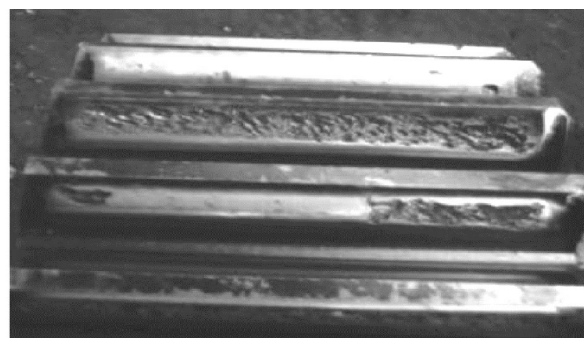

Fig. 15 – Damaged working surfaces of the sun gear teeth

**6. Conclusions.** The presented models and methods are the basis for calculation and information support of the life cycle of planetary transmissions of mobile machines. Many of them are of a universal nature and can be applied to a wide range of technical objects. A number of practical examples of the application of methods are presented in the monograph [21]. Some elaborated methods are included in state standards and used for development and exploitation of technically complicated items of enterprises of Belarus.

#### References

1. Raghavan M. Synthesis of Transmissions with Four Planetary Gearsets. *Proc. of The 14th IFToMM World Congress, Taipei, Taiwan, Oct. 25–30 2015* (5 pages); URL: <http://www.iftomm2015.tw/IFToMM2015CD/PDF/OS17-009.pdf> (accessed on Feb. 2018).
2. Tsai L. W. An Application of the Linkage Characteristic Polynomial to the Topological Synthesis of Epicyclic Gear Trains. *ASME Journal of Mechanisms, Transmissions, and Automation in Design*, 1987, 109, September, 329–336.
3. Chatterjee G. and Tsai L. W. Enumeration of Epicyclic-type Automatic Transmission Gear Trains. *Transactions of SAE Technical Paper*. 12.10.94.
4. Hsu C.-H., Yeh Y.-C. and Yang Z.-R. Epicyclic Gear Mechanisms for Multi-Speed Automotive Automatic Transmissions. *Proc. Natl. Sci. Counc. ROC(A)*. 2001, 25(1), pp. 63–69.
5. Salamandra K. B. Modern Methods of Synthesis of Automatic Planetary Gearboxes. *Scientific journal "Izvestiya MG TU "MAMI"*. 2017. 3(33). PP.49–55. (in Russian)
6. Adams Machinery. *A Powerful Simulation Suite for Mechanical Drive Systems*. URL: <http://www.mscsoftware.com/product/adams-machinery> (accessed on Feb. 2018).
7. Simscape Driveline. *Model and Simulate Rotational and Translational Mechanical Systems*. URL: <https://www.mathworks.com/products/simdrive.html> (accessed on Feb. 2018).
8. MapleSoft. *Transmission Modeling and Simulation with MapleSim*. URL: [http://www.maplesoft.com/contact/webforms/whitepapers/transmissionmodeling\\_download.aspx](http://www.maplesoft.com/contact/webforms/whitepapers/transmissionmodeling_download.aspx) (accessed on Feb. 2018).
9. KissSoft. *Gearbox Calculation Package GPK. The Standard for Industry Gearboxes*. URL: <http://www.kisssoft.ch/english/downloads/gpk/Flyer-E.pdf> (accessed on Feb. 2018).
10. APM. *WinMachine*. URL: <http://apmwm.com/Products> (accessed on Feb. 2018).
11. Bertsche B. *Reliability in Automotive and Mechanical Engineering*, Springer. – 2008.
12. ReliaSoft. *Software and Solutions for Reliability and Maintainability Analysis*. URL: <https://www.reliasoft.com> (accessed on Feb. 2018).
13. Hähnel A., Lemaire M., Rieuneau F. and Petit F. Machines and Mechanisms Design for Reliability. *12th IFToMM World Congress, Besançon (France), Ju.18–21, 2007*. (7 pages)
14. Liu L. and Zio E. *Dynamic Reliability Assessment and Prognostics with Monitored Data for Multiple Dependent Degradation Components*. In book: Risk, Reliability and Safety: Innovating Theory and Practice: 2016, pp. 736–741.
15. Kapur K. C. and Lamberson L. R. *Reliability in Engineering Design*, John Wiley & Sons, 1977.
16. Zakrajsek J. J. *An Investigation of Gear Mesh Failure Prediction Techniques*. NASA Technical Memorandum 102340, 1989.
17. Salem A. A. *Condition Monitoring of Gear Systems Using Vibration Analysis*, University of Huddersfield, Doctoral Thesis, 2012.
18. Wirtz S. F., Beganovic N., Tenberge P., and Söffker D. *Gear Transmission Monitoring 4.0: What Can Be Expected from Upcoming Diagnostic and Prognostic Systems?*, Institut für Maschinentechnik der Rohstoffindustrie, RWTH Aachen, 2016.
19. Algin V. *Computation of mobile technics: kinematics, dynamics, life*. Belaruskaya navuka, Minsk: 2014 (in Russian).
20. Ishin N. *Dynamics and vibration monitoring of gears*. Belaruskaya navuka, Minsk: 2013 (in Russian).
21. Algin V., etc. *Gears and Transmissions in Belarus: Design, Technology, Estimation of Properties*, Algin V. and Starzhisky V. (Eds.). Belaruskaya Navuka, Minsk: 2017 (in Russian).

Received 26.03.2018

#### Відомості про авторів / Сведения об авторах / About the Authors

**Альгин Володимир Борисович (Альгин Владимир Борисович, Algin Vladimir Borisovich)** – доктор технічних наук (Dr. habil. of Eng. S.), професор, державна наукова установа "Об'єднаний інститут машинобудування Національної академії наук Білорусі", заступник генерального директора з наукової роботи; м. Мінськ, Білорусь; e-mail: [Vladimir.algin@gmail.com](mailto:Vladimir.algin@gmail.com)

**Гаврилов Сергій Олексійович (Гаврилов Сергей Алексеевич, Gavrilov Sergey Alekseevich)** – кандидат технічних наук (PhD in Eng. S.), виробничо-сервісне підприємство "Полтава-Автокомплект", директор; м. Горішні Плавні Полтавської обл., Україна; e-mail: [p.avtokomplekt@ukr.net](mailto:p.avtokomplekt@ukr.net)

**Ішин Микола Миколайович (Ишин Николай Николаевич, Ishin Nikolai Nikolaevich)** – доктор технічних наук (Dr. habil. of Eng. S.), доцент, державна наукова установа "Об'єднаний інститут машинобудування Національної академії наук Білорусі", директор науково-технічного центру "Кар'єрна техніка"; м. Мінськ, Білорусь; e-mail: [nik\\_ishin@mail.ru](mailto:nik_ishin@mail.ru)

**Максимченко Наталія Миколаївна (Максимченко Наталья Николаевна, Maksimchenko Natalia Nikolaevna)** – кандидат технічних наук (PhD in Eng. S.), державна наукова установа "Об'єднаний інститут машинобудування Національної академії наук Білорусі", провідний науковий співробітник лабораторії приводних систем і технологічного обладнання; м. Мінськ, Білорусь; e-mail: [maksnat2001@mail.ru](mailto:maksnat2001@mail.ru)