

Published version at <https://doi.org/10.1063/1.5053522>

Design and Analysis of Performance of a DC Power Optimizer for HCPV Systems within CPVMatch Project

Ricardo Alonso^{1, a)}, Ainhoa Pereda¹, Eneko Bilbao², Jose Antonio Cortajarena^{2, b)},
Iñigo Vidaurrazaga¹ and Eduardo Román¹

¹*Tecnalia, c/Geldo Edificio 700 E-48160 Derio (Spain)*

²*Engineering School of Gipuzkoa (UPV-EHU), c/Otaola 29 E-20600 Eibar (Spain)*

^{a)} Corresponding author: ricardo.alonso@tecnalia.com

^{b)} josean.cortajarena@ehu.es

Abstract. As most of PV systems, CPV systems are also affected by mismatching losses, particularly due to misalignment of optics and receivers. As a result, module level power electronics can help to increase their energy yield by making every CPV module deliver its maximum power at the output. Among the different alternatives, solutions based on DC power optimizers exhibit higher conversion efficiencies and lower costs than microinverters. However, while microinverters ensure optimal operation independently from the operating conditions, system design with DC power optimizers must be carefully examined to avoid potential underperformance. This paper describes not only the customized design and validation of a high-efficiency and economical DC power optimizer for HCPV systems, but also a comprehensive analysis of the whole system design to optimize its production under expected working conditions.

INTRODUCTION

Microinverters and DC power optimizers are collectively referred to as Module Level Power Electronics (MLPE). MLPE enhances overall performance of PV systems by constantly tracking the Maximum Power Point (MPP) of each module individually [1]. The benefit comes from the reduction of mismatching losses. These losses appear when modules are directly connected in series showing different I-V characteristics and MPPs. As a result, it is impossible to harvest all the available energy in the PV string, since modules directly connected in series are forced to operate at the same current and, in general, far from their MPP. Deviations between modules can be caused by different working conditions or divergences in the manufacturing and degradation processes.

CPV systems also consist of strings with serially connected modules and, consequently, they are also impacted by mismatching losses. Moreover, CPV systems can be affected by additional mismatching sources. In fact, misalignments within a CPV module are mostly caused by shifting and tilting of optical components and receivers. And it is even worse when mounting multiple modules on a single tracker, since structural bending by gravity and wind results in higher levels of misalignment. Therefore, MLPE can also improve the energy output of CPV systems. Indeed, some experimental test results under normal operation validate that power losses in a CPV system can be reduced by more than 5% by using microinverters [2]. In this work, instead of adding a microinverter to every CPV module, serial DC power optimizers are proposed to offer the same benefits with lower costs and greater reliability, mainly due to its simplicity. To this regard, it is important to note that microinverters must comply with all the grid-connection requirements, including the voltage conversion from the HCPV panel at the input to the required high AC voltage at the output. Meanwhile, serial DC power optimizers must only implement MPP tracking and manage quite lower conversion efficiencies, since required AC voltage levels for grid-connection is achieved through their connection in series and a centralized inverter, as shown in Fig. 1. Nevertheless, DC power optimizers present some limitations that must be studied in detail during system design to ensure an optimal performance under expected mismatching effects at least.



FIGURE 1. System layout based on microinverters (a) and serial DC power optimizers (b).

The following chapter is precisely focused on this problematic and the aspects that must be considered when designing such a distributed system. In the subsequent chapter the design of the proposed DC power optimizer is described in detail. Finally, results from the experimental tests conducted in laboratory are exposed.

CPVMATCH SYSTEM DESIGN

Within H2020-EU funded CPVMatch project (*Concentrating Photovoltaic modules using advanced technologies and cells for highest efficiencies*), different technical approaches have been addressed to enhance the performance of HCPV systems. System design parameters considered for this work are (1) expected mismatching sources, (2) electrical parameters of CPVMatch Mirror-Based (MB) module (collected in Table 1) and (3) number of modules per system. To this regard, a tracker system of more than 90m² is foreseen hosting 100 CPVMatch MB modules.

TABLE 1. Electrical parameters of CPVMatch MB module.

Parameter	Value	Unit
Open circuit voltage	46.74	V
Short circuit current	13.01	A
MPP voltage	42.45	V
MPP current	12.8	A
Nominal Power	543W	W

Analyzing the potential mismatching sources, the following assumptions have been reasoned:

1. Dispersion in manufacturing processes and temperature operation of optical devices (mirrors and secondary optics) could result in current deviations of up to 10% between modules. In fact, considering only temperature effects, spatial gradients of 30°C have been reported inside a HCPV module [3] causing energy divergences of 10% due to losses in lenses, according to [4].
2. Despite CPVMatch supporting structure stiffness, a minimum misalignment between modules is supposed due to the installation process and flexure of the tracker under windy conditions resulting in additional current deviations of 5%. For this estimation it has been taken into account that the acceptance angle of CPVMatch MB module is 0.5° and flexures of up to 0.3° have been previously measured in the field in trackers with a more reduced aperture area of 48m² [5].
3. Dispersion of parameters in AZUR SPACE PV cells manufacturing process is neglected, since divergency values lower than 2% have been measured, according to data provided by ASSE on a lot of 100 cells.
4. Mismatching inside the CPVMatch module can be neglected, excluding potential total failures or severe dirtiness in few PV cells, whose effects are minimized by means of the internal 15 by-pass diodes.
5. Mismatching due to soiling has been discarded as it can be cleaned when it is significant enough.

According to these assumptions and CPVMatch system configuration, it has been considered that this can be only affected by a limited number of mismatched modules (50% of modules in a string as maximum) with low mismatching level (15% of reduction in generated current as maximum).

Regarding DC power optimizer topology, if the same conversion range is considered in all of them, buck, boost, and buck-boost can cope with the same mismatching casualties, determined by the number of mismatched modules in the string and their mismatching level [6]. However, when selecting the topology, it must be considered that with

buck converters only mismatched modules must operate at high conversion ratios to reach the string current at the output, while with boost converters non-mismatched modules are the ones boosting their voltage to reduce the string current up to the current generated by the most mismatched module. Buck-boost topology is a trade-off between both and it is frequently used in commercial power optimizers offering a great flexibility in the system design. However, if the system shows fixed specifications and few modules are presumed to be mismatched, the most suitable topology is the buck converter to minimize conversion ratio and, hence, conversion losses in non-mismatched modules. Additionally, higher conversion efficiencies are normally achieved with buck topology due to its simplicity. Obviously, it is important to note that the number of modules per string must be enough to reach the required voltage level at the input of the inverter. In this case, MPP voltage (42.45V) and number of modules in the system (100) make this possible, arranging them in 5 parallel strings of 20 CPVMatch MB modules in series.

In relation to the required conversion range, a 1.17 should be enough to cope with the maximum expected mismatching level of 15%, according to [6]. Nevertheless, this would mean that the inverter voltage must be adapted to operating conditions at every moment. If a constant inverter voltage is required, a larger conversion range must be selected. With the aim of limiting power conversion losses and related dissipation management issues in the designed buck converter, maximum conversion ratio is restricted to 1:0.5 and, thus, the conversion range is 2.

Then, output power-voltage curves under different operating conditions can be simulated to select the most suitable constant voltage level at the input of the inverter. The aim is to ensure maximum conversion efficiency and capability to cope with all the mismatching casuistries. In this sense, it can be demonstrated that worst cases are for a single module with the highest mismatching level and for the maximum number of potentially simultaneously affected modules with the same mismatching level. The ideal operation conditions, without mismatching effects, and these two worst cases are gathered in Table 2 and displayed in Fig. 2, showing maximum available power of 20 modules and required inverter voltage to get it, when operating without and with proposed buck converter. As it can be seen, 650V is a suitable string voltage value at the input of the inverter. This way, maximum power is assured to be extracted in all the casuistries and non-mismatched modules operate with a maximum conversion ratio of 1:0.85.

TABLE 2. Ideal operating conditions and worst cases for a string composed of 20 CPVMatch MB modules with and without DC power optimizers.

Mismatched modules (%)	Mismatching level (%)	Maximum power(W) @ required string voltage(V)
0%	-	9594W @ 764V (without buck converter)
5%	15%	9114W @ 725V (without buck converter)
50%	15%	8482W @ 784V (without buck converter)
0%	-	9594W @ 382-764V (with buck converter)
5%	15%	9532W @ 444-759V (with buck converter)
50%	15%	8974W @ 418-714V (with buck converter)

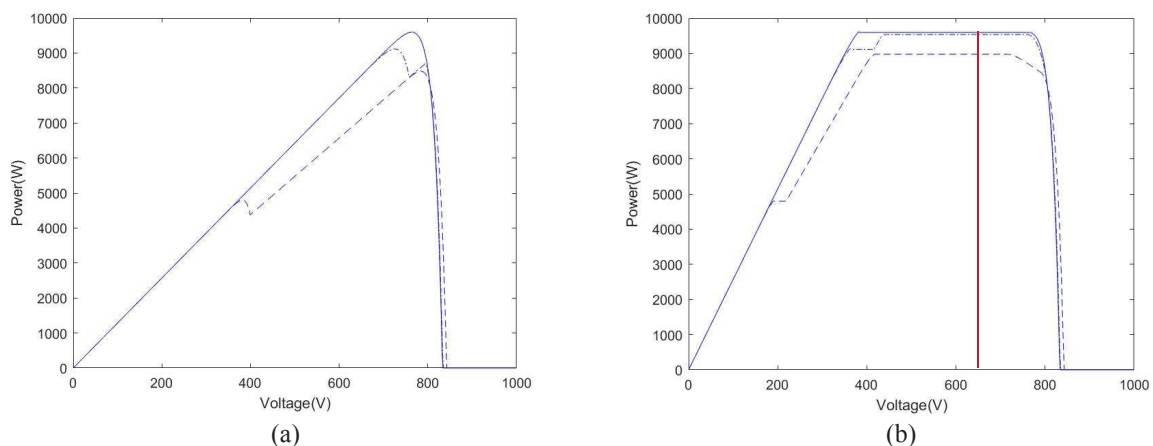

FIGURE 2. P-V curves for cases listed in Table 2 for a system without (a) and with (b) buck converters: 0% of modules affected (solid line), 5% (dashed-dotted line) and 50% (dashed line).

DC POWER OPTIMIZER DESIGN

Hardware Design

As stated before, the selected DC-DC converter topology for CPVMatch system is a buck converter. More concretely, the specific power conversion topology is a synchronous buck converter consisting of two MOSFETs switching at 20kHz, a 100uH power inductor and 1mF input and output capacitors. Its nominal power is 500W with a maximum absolute rating of 550W.

As displayed in Fig. 3, apart from the power conversion stage, the DC power optimizer also includes:

1. Control electronics based on 16F886A microcontroller, in charge of MPP algorithm implementation and communication management.
2. Analog measurement conditioning electronics to filter and adapt HCPV voltage, current and temperature to voltage levels required by the analog-digital converter.
3. Power Line Communications (PLC) for module level monitoring based on ST7540 at 132kHz. This remote monitoring capability of HCPV module voltage, current and temperatures means a helpful tool for supervision and maintenance activities.
4. A power supply generating from HCPV module voltage input the internal voltage sources required by microcontroller (+3V3), analog measurement conditioning (+5V), MOSFET drivers (+10V_DRV) and PLC communications (+10_PLC).

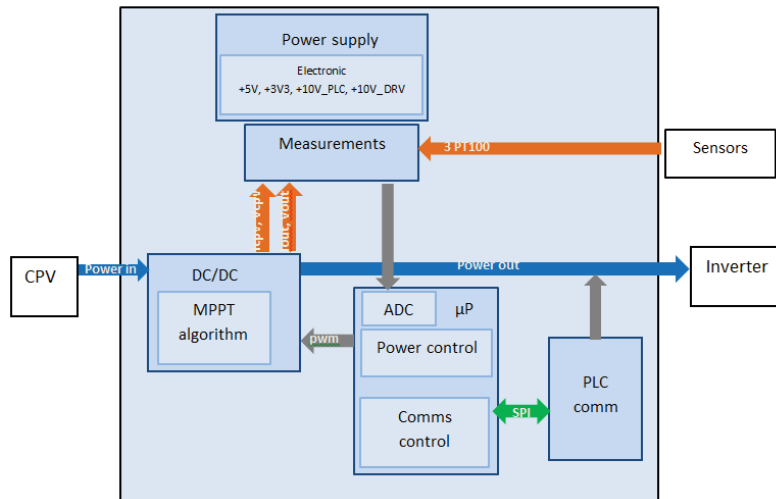

FIGURE 3. Hardware block diagram of CPVMatch DC power optimizer.

Production cost of the designed prototype, shown in Fig. 4, has been preliminarily estimated around 15c€/Wp for 1,000 units, being an unpackaged solution to be integrated within HCPV junction box. This cost should be compensated by incomes derived from energy yield optimization and O&M activity improvement.



FIGURE 4. CPVMatch DC power optimizer prototype.

Maximum Power Point Tracking Algorithm

The MPP tracking technique is a modified Perturbation & Observation (P&O) algorithm incorporating:

1. Power compensation to avoid wrong searching actions in case of changing conditions, like during tracker mechanical movement. This means an intermediary measurement of output power to distinguish between the effect of the perturbation and the effect of the variability of operating conditions.
2. MPP detection method to avoid oscillations around the optimal operating point. This consisting in stopping perturbing the system after a certain period of continuous opposite perturbation signals and while output power keeps constant. This increases MPP tracking accuracy, considering that HCPV modules are installed in areas with high solar radiation, where operating conditions generally remain stable. The perturbation step is either periodically reactivated or as soon as output power fluctuates.
3. Adaptable perturbation step improving simultaneously its accuracy and response time. This is achieved by increasing perturbation step when this keeps the same direction and reducing it when it is in the opposite direction.

On the other hand, as CPVMatch module is a packaged assembly of individual HCPV cells with their specific concentrator and protecting by-pass diode, its output I-V characteristic can present local MPPs. Consequently, the implemented MPP tracking method must be able to find the global MPP. This is achieved by means of a fast and reliable checking stage that considers the potential particularities of CPVMatch module I-V characteristic [7].

DC POWER OPTIMIZER EXPERIMENTAL RESULTS

Developed CPVMatch prototype has been tested in laboratory to characterize its power conversion and MPP tracking efficiencies. The power conversion efficiency has been measured at different input voltages, conversion ratios and power levels. European efficiency is greater than 98% for the nominal MPP voltage (42.3V) and conversion ratios higher than 0.85, corresponding to modules with a reduction of 15% in generated current. Figure 5 shows measured conversion efficiencies as a function of input power with a conversion ratio of 0.85.

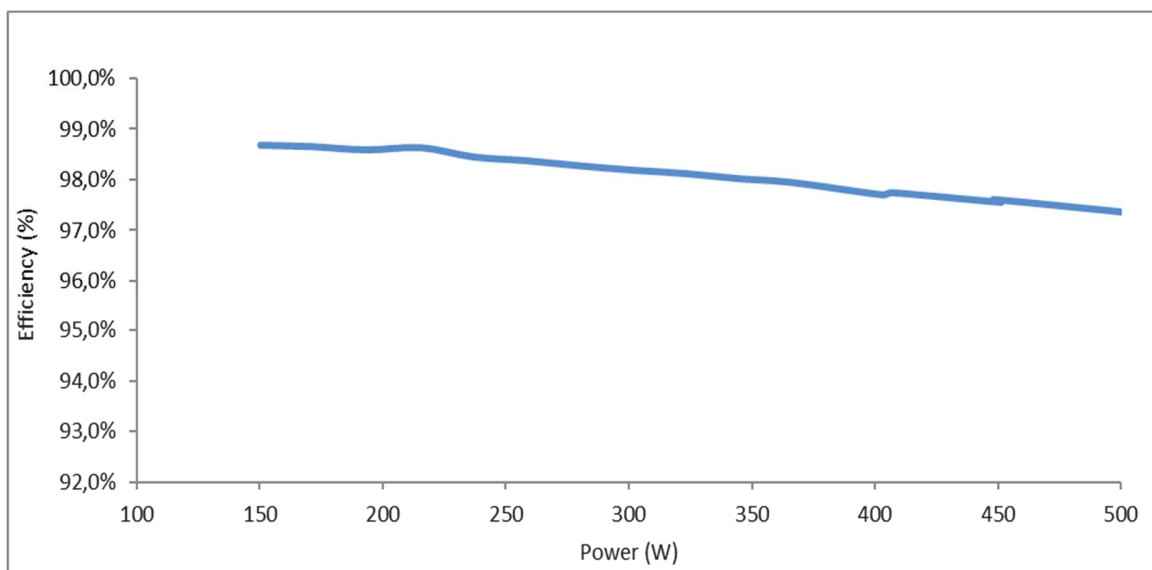

FIGURE 5. Measured conversion efficiency of CPVMatch DC power optimizer as a function input power.

Static and dynamic MPP tracking efficiencies have been evaluated according to European standard EN50530, obtaining values higher than 99.9% in both cases. Additional tests have been performed emulating CPVMatch module IV curves with different local MPP configuration. Test results confirm that MPP tracking algorithm finds the global MPP in a fast, efficient and accurate way.

Finally, a system composed by two DC power optimizers connected in series to a DC voltage regulated load has been validated checking MPP tracking interoperability and communication capabilities at system level.

CONCLUSIONS

The scope of this work is the design of a distributed MPPT architecture for CPVMatch HCPV MB system and the consequential development and prototyping of a customized DC power optimizer for CPVMatch HCPV MB module.

Firstly, considering CPVMatch module specifications, number of modules in the system and potential mismatching sources, a buck converter has been determined as the most suitable DC power optimizer topology to enhance system conversion efficiency. Then, a constant voltage of 650V at the input of the centralized inverter has been selected to ensure high system conversion efficiency and delivery of the maximum available power at every moment, independently from mismatching casuistry. In relation to this, a previous study of expected mismatching sources has been carried out, concluding that the highest foreseen mismatching level is 15% affecting to 50% of modules, as maximum.

With these assumptions, electrical simulations show that DC power optimizers can ideally increase in up to 5% the energy yield of a string and near to 10% in the system, since MPP voltage of the different strings could be different. However, DC power optimizers actually introduce around 2% of power conversion losses, resulting in a maximum overall improvement of around 8%.

For this purpose, a high efficiency and low cost synchronous buck converter has been developed and experimentally tested in laboratory, validating its functionalities and specified conversion efficiency. This device also incorporates PLC communications to improve module level condition monitoring and, hence, system supervision and maintenance activities.

Future work will be focused on in field characterization of HCPV system mismatching losses to confirm initial assumptions and if this proposed DC power optimizer is worthwhile, considering that its extra cost (around 15c€/Wp) must be compensated by incomes coming from energy yield increase and from benefits derived from operation and maintenance improvement.

ACKNOWLEDGMENTS

Main design specifications (electrical parameters of module and number of modules per tracker), as well as supporting information for mismatching losses estimation, have been provided by ASSE within CPVMatch project.

This work has received funding from the European Union's Horizon 2020 research and innovation programme within the project CPVMatch under grant agreement No 640873. The authors are solely responsible for the content of this work and it only reflects the author's view.

REFERENCES

1. G. Petrone, G. Spagnuolo and M. Vitelli, "Distributed Maximum Power Point Tracking: Challenges and Commercial Solutions", in *Automatika* 53:2, 2012, pp. 128-141.
2. Y.S. Kim and R. Winston, "Power conversion in concentrating photovoltaic systems: central, string and microinverters" *Progress in Photovoltaics: Research and Applications*, 2014.
3. M. Martínez, D. Sánchez, F. Rubio, E. F. Fernández, F. Almonacid, N. Abela, T. Zech and T. Gerstmaier, "CPV Power Plants", in *Handbook of Concentrator Photovoltaic Technology*, edited by C. Algora and I. Rey-Stolle, John Wiley & Sons, Ltd, 2016.
4. M. Wiesenfarth, S. Gamisch, H. Kraus, and A.W. Bett. "Investigations on 3-dimensional temperature distribution in a FLATCON-type CPV module" *AIP Conference Proceedings* 1556, 189 (2013).
5. I. Luque-Heredia, P. Malgalhaes and M. Muller, "CPV Tracking and Trackers" in *Handbook of Concentrator Photovoltaic Technology*, edited by C. Algora and I. Rey-Stolle, John Wiley & Sons, Ltd, 2016.
6. R. Alonso, E. Roman, A. Sanz, V.E. Martínez, P. Ibáñez, "Analysis of Inverter Voltage Influence on Distributed MPPT Architecture Performance", *IEEE Transaction on Industrial Electronics*, Vol: 59, Issue: 10, 2012.
7. R. Alonso, P. Ibáñez, V.E. Martínez, E. Román, A. Sanz, "An Innovative Perturb, Observe and Check Algorithm for Partially Shaded PV Systems", *13th European Conference on Power Electronics and Applications*, 2009.