

# The in-process control of PVC sheath of a double core cable

N S Galeeva<sup>1</sup>, V V Redko<sup>2</sup> and L A Redko<sup>2</sup>

<sup>1</sup> Assistant Professor, National Research Tomsk Polytechnic University, Tomsk, Russia

<sup>2</sup> Associate Professor, National Research Tomsk Polytechnic University, Tomsk, Russia

E-mail: nadushasns@sibmail.com

**Abstract.** In this work the possibility of the sheath hermiticity testing by measuring of the cable capacity per unit length variation during spark testing is considered. The research object is 2×0.75 HO3VVH2-F cable. According to the physical modelling it is proved that such defect of sheath as pinhole through the whole thickness of sheath can be registered for the test length 10 cm with test voltage frequencies 1kHz and 10kHz.

## 1. Introduction

Cable products are applied for transmission of electrical energy and information at a distance. Cable products are long-length objects, so its production is a resource-intensive process. Thus, to decrease mass marriages and production costs a regulation of the process should be conducted at time. It is possible to achieve with quality in-process control [1–5].

One of the most typical cable construction parts is nonmetallic cable sheath [1–12]. This construction part is applied for overall mechanical, chemical, weather and electrical protection.

According to the regulatory documentation [13, 14] the in-process control of nonmetallic cable jacket is carried out by spark testing. According to this testing method the cable core is grounded and a high test voltage is applied to the insulation surface with specialized electrode. When an insulation flaw is passing through the controlled area, a breakdown occurs and is registered by the automatics.

The regulatory documentations for each type of cable products determine the requirements for the nonmetallic cable sheaths. There are two main requirements. First of all, decreasing of a sheath thickness must not be excess 15...25 % from the defect-free sheath for each type of cable products. Secondly the cable sheath must be hermetical [15–18].

Nowadays, the in-process control of sheath hermiticity is carried out only for sheaths applied over a metallic shield or an armour. Otherwise the test voltage is not possible to apply to the cable sheath. But the hermiticity of cable sheath must be tested for any cable construction according to the regulatory documentation. Thus, the current problem is to develop a method that is able to test the nonmetallic cable sheath which is applied over the nonmetallic parts of cable.

In the previous article [19–24] the method was offered for cable capacitance recording during spark testing. In this article the possibility of the hermiticity test of cable sheath is explored. This research is conducted for cable type 2×0.75 HO3VVH2-F (it is European analog of Russian cable SHVVP 2×0.75).

## 2. Object of testing

2×0.75 HO3VVH2-F cable is a flexible double core cable with a double PVC coating (Figure 1).



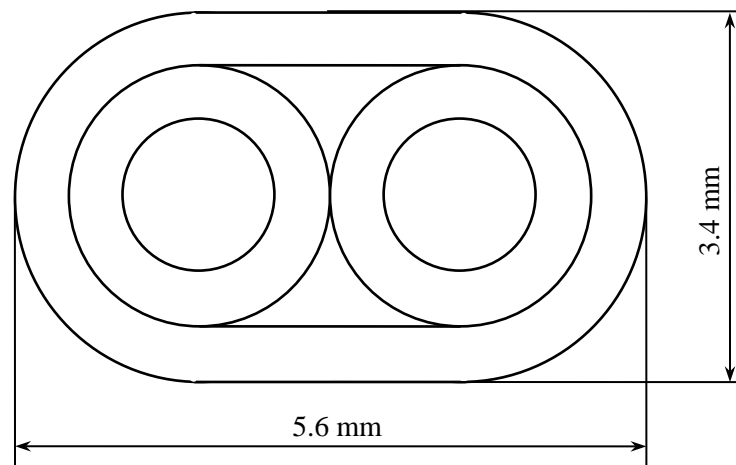
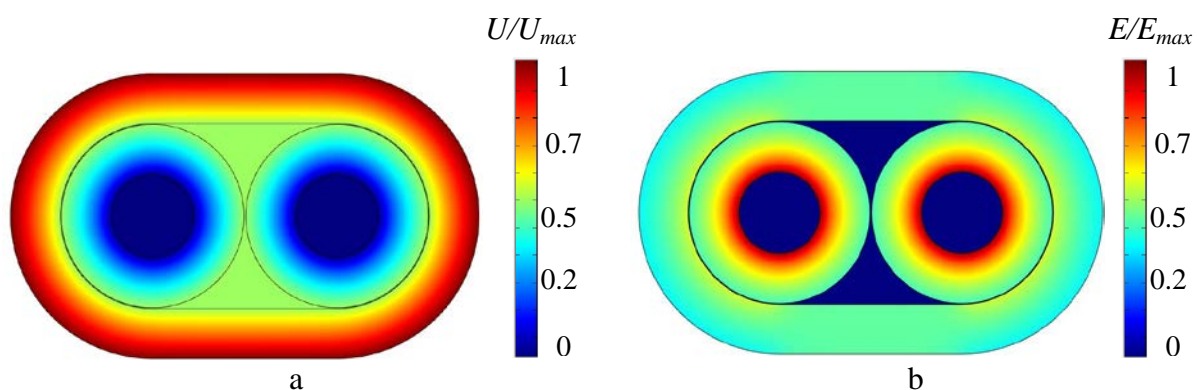

**Figure 1.** Construction of 2×0.75 HO3VVH2-F.

Processing of this cable has 2 stages. On the first stage melted plastic pellets are applied over conductor during the extrusion process. On the second stage melted plastic pellets are applied over pair of insulated core. According to the regulatory documentation the sheath and the insulation of its cable must be able to be separated freely [15–18]. Thus, there is no adhesion between these elements. Because the cable work voltage is 380 V (for Russian analog), gaps between the insulated cores and the sheath are not filled with insulating material.

### 3. Hypothesis

In the absence of adhesion it is suggested that there is a thin air layer in the place of insulation and sheath contact. The value of a high voltage for the spark testing is chosen in accordance with the standards [13, 14]. While the high testing voltage is applied to the cable surface, the initial value of electric field strength for the air gaps is much more the dielectric strength of air. Thus, the air gaps between the insulation and sheath in a strong field may be considered as conducting areas. Based on this hypothesis the mathematical model of the cable has been developed in the program of finite element analysis. Using this model the electric field and potential distributions for cable cross section during the spark testing have been obtained. In the Figure 2 the sheath is defect-free.



**Figure 2.** The potential (a) and electric field (b) distributions for cable 2×0.75 HO3VVH2-F cross section during the spark testing in case of defect-free sheath.

The cable hermiticity is broken in case of the pinhole through the whole thickness of sheath. The pinhole can be represented as thin cylindrical air gap from external to internal sheath surface.

The electric field and potential distributions for cross section of cable with defect sheath during the spark testing significantly differ from the defect-free one (Figure 3).

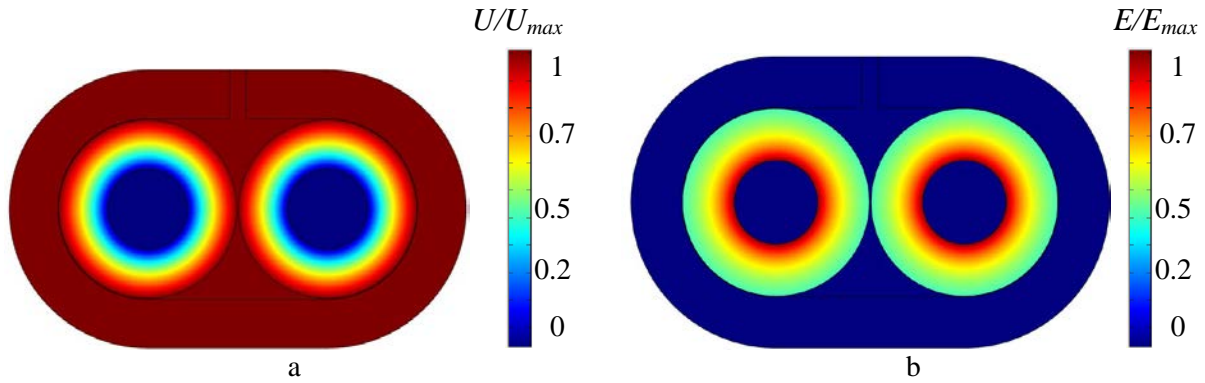

**Figure 3.** The potential (a) and electric field (b) distributions for cable 2×0.75 HO3VVH2-F cross section during the spark testing in case of defect sheath.

It can be noted that such potential and electric field distributions is not only in cross section of pinhole defect, but in whole test length of cable, according to the hypothesis.

The electrical equivalent circuit of a cable with defect-free sheath is presented in the Figure 4a. The capacity per unit length ( $C_{\Sigma}$ ) is

$$C_{\Sigma} = \frac{2 \cdot C_s \cdot C_{ins}}{C_s + 2 \cdot C_{ins}}, \text{ where}$$

$C_s$  is the equivalent capacity per unit length of cable sheath,  $C_{ins}$  is the equivalent capacity per unit length of single insulated core.

In case of sheath with pinhole the equivalent capacity  $C_s$  is shunted (Figure 4b).

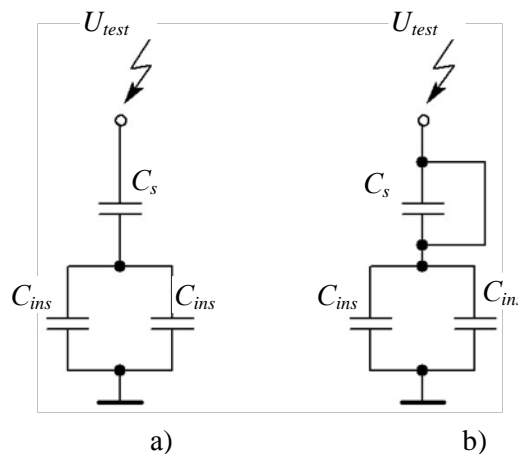

**Figure 4.** The equivalent electric circuit of the cable HO3VVH2-F with a defect-free sheath (a) and defect sheath (b).

Then, the capacity per unit length ( $C'_{\Sigma}$ ) is

$$C'_{\Sigma} = 2 \cdot C_{ins} \cdot$$

Thus, according to the hypothesis the capacity per unit length is significantly increase in case of pinhole through the whole thickness of sheath. Due to this effect the defect can be registered during the in-process control.

To verify this state the physical modeling of the cable with defect sheath in a strong electric field is provided.

#### 4. Physical modelling

Initial experiments were carried out in weak electric fields, i.e. the electric field in the cable was much weaker than air dielectric strength. Measurement of the cable capacity was carried out according to the instructions of the state standard for measuring the electrical capacity of the wire [18].

To match this physical model with a real cable in strong fields, the air gap between the insulations and the sheath of the cable should have good conductive properties. To fulfill this condition, the air gap was filled with a concentrated 20 % NaCl salt solution.

#### 5. Experiment

To provide the experiment two test samples of the cable is prepared. The first test sample is the cable with defect-free sheath, the second one is with defect sheath. To prevent an end effect the length of the test samples is 700 mm. The sheath defect of second test sample is pinhole from the external to the internal sheath surface. The pinhole diameter is 0.75 mm. The test samples are immersed partly in a metal tank with water, according to the measurement procedure specified in the standard [25–30]. Measurements are provided with the digital LCR meter AM-3001, which basic accuracy does not exceed 0.05 %. One of the LCR meter contacts is connected to the conductive parts of the cable, the other contact is connected to the metal tank with water, which has been grounded. The drive voltage of the LCR meter is 1 V, a parallel equivalent circuit of measurements is chosen.

The empirical dependence of the relative variation of cable capacitance  $\delta$  from the test length  $l$  is presented for the several frequency values (Figure 5). The formula for the calculation of the parameter  $\delta$  is

$$\delta = \frac{C_d - C}{C} \cdot 100\%$$

where  $C_d$  is the electric capacity of the cable with defect sheath,  $C$  is the electric capacity of the cable with defect-free sheath. The test length is the length of immersed part of the test sample.

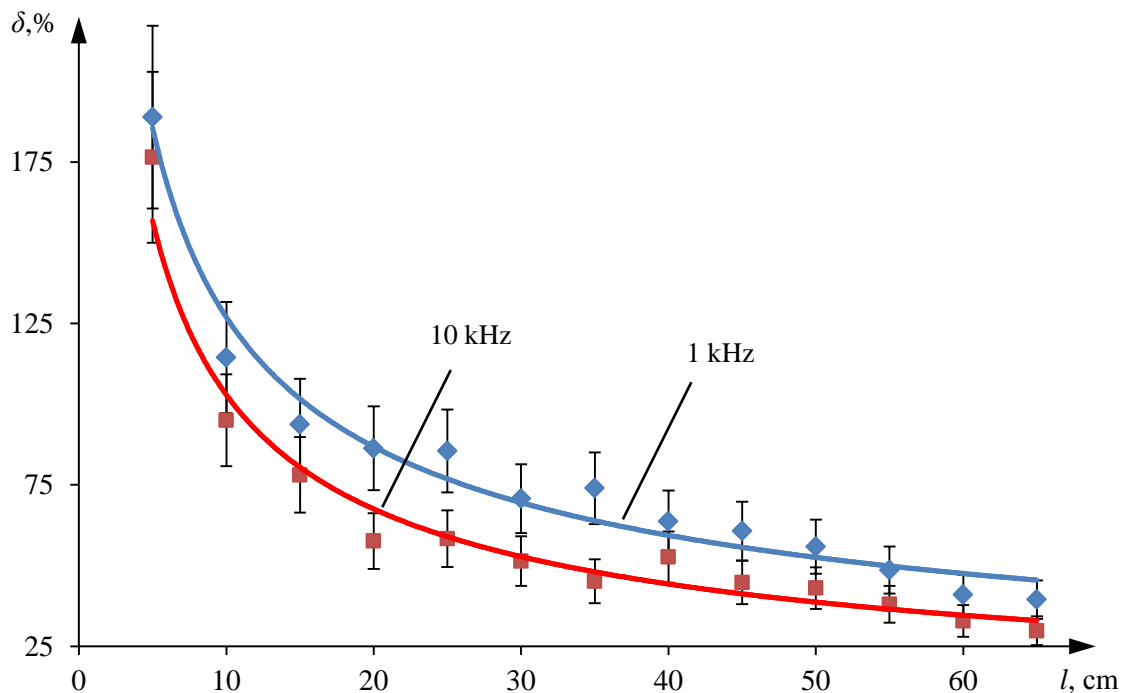

**Figure 5.** The empirical dependence of the relative variation of cable capacitance from the test length.

Analysis of the obtained data has shown the exponential behavior of the dependences. For the maximal test length  $l = 65$  cm the sheath pinhole leads to capacity variation about 9 % with test voltage frequency 100 kHz, 25 % variation with frequency 10 kHz and 38 % variation with 1 kHz frequency. The most important results for this experiment are obtained for the test length  $l = 10$  cm, because this is the most commonly used electrode length for the in-process spark testing. The variation for this length is about 120 %, 100% and 22 % for the 1 kHz, 10 kHz and 100 kHz test voltage frequencies respectively.

## 6. Summary

This work describes the possibility of the sheath hermiticity testing by measuring of the cable capacity per unit length variation during spark testing. The cable  $2 \times 0.75$  HO3VVH2-F is proposed as a model. It is important, that spark testing is in-process method of testing. For this reason dead zone is 20 % from nominal value of measuring cable capacity. This value is defined to reduce the number of the false alarm. In case the test length is 10 cm, the physical modeling results show that variation of the capacity is higher than the insensitivity level. Thus, it was found that the defect through the whole thickness of sheath can be registered by given method with frequencies 1 kHz and 10 kHz.

The aim of the further research is verification of the obtained results by the measurements of the cable capacity per unit length variation performed with the spark tester with additional options of cable capacity measuring.

## References

- [1] Cadick J 2004 *Cables and Wiring* (New York: Delmar Publishers) p 244
- [2] 1956 *Electrical wire and cable handbook* (Pittsburgh: United States Steel Corporation) p 237
- [3] Gorodetsky S S and Lackernik R M 1971 *Testing of cables and wire* (Moscow: Energy) p 272
- [4] Sclater N 1991 *Wire and cable for electronics: a user's handbook* (New York: McGraw Hill) p 237
- [5] Goldshtein A E and Fedorov E M 2010 *Russ. J. Nondestr. Test.* **46** 424–430 doi: 10.1134/S1061830910060069

- [6] 1969 *Engineering Design Handbook: Electrical Wire and Cable* (Alexandria, VA, National Technical Information Service) p 297
- [7] Cousins K 2000 *Polymers for Wire and Cable – Changes Within an Industry* (Shawbury, UK Smithers Rapra Technology) p 122
- [8] Privezentsev V 1973 *Fundamentals of Cable Engineering* (Moscow: Mir) p 407
- [9] 1971 *Cable Engineering* (Fort Belvoir, Defense Technical Information Center) p 54
- [10] *Term and Definition* (Fontana, CA, Custom Wire Harnesses & Specialty Connectors) [Electronic resource] URL: <http://www.dsmt.com/pdf/resources/glossary.pdf>
- [11] Horn F W and Bleinberger W E 1966 *Design and manufacture of plastic insulated aluminum conductor telephone cable* (Fort Belvoir, Defense Technical Information Center) p 31
- [12] 2007 *Advances in high voltage engineering* (Stevenage: The Institution of Engineering and Technology) p 669
- [13] 2004 BS 5099:2004 *Electric cables. Voltage levels for spark testing* (UK: BSI)
- [14] 2000 UL 1581 *Reference Standard for Electrical Wires, Cables, and Flexible Cords* (Underwriters Laboratories Inc., Northbrook)
- [15] 2003 GOST 7399-97 *Wires and cords of voltage up to and including 450/750 V. Specifications.* (Minsk:IPK Izatel'stvo standartov) (in Russian)
- [16] 2003 GOST 2990-78 *Cables, wires and cords. Methods of voltage test.* (Moscow: IPK Izatel'stvo standartov)
- [17] 2011 EN 50525-2-71:2011 *Electric cables - Low voltage energy cables of rated voltages up to and including 450/750 V (U0/U) – Part 2-71: Cables for general applications - Flat tinsel cables (cords) with thermoplastic PVC insulation* (UK, BSI)
- [18] 2011 EN 50525-2-11:2011 *Electric cables - Low voltage energy cables of rated voltages up to and including 450/750 V (Uo/U) – Part 2-11: Cables for general applications - Flexible cables with thermoplastic PVC insulation* (UK, BSI)
- [19] Redko V V, Starikova N S, Redko L A and Vavilova G V 2015 *IOP Conf. Ser.: Mater. Sci. Eng.* **81** 012083 doi: 10.1088/1757-899X/81/1/012083
- [20] Drobny J G 2012 *Polymers for Electricity and Electronics: Materials, Properties, and Applications* (New York: Wiley) p 352
- [21] Tsaliovich A 1995 *Cable Shielding for Electromagnetic Compatibility* (US: Springer) p 469
- [22] Leonov A P and Charkov D I 2017 *MATEC Web Conf.* **91** 01030 doi: 10.1051/mateconf/20179101030
- [23] 2012 *GOST R 54813-2011 Electric cables, wires and cords. Spark test method* (Moscow: Standartinform) (in Russian)
- [24] 2008 *GOST R 23286-78 Cables, wires and cords. Standards for insulation and sheath thickness and voltage tests* (Moscow: Standartinform) (in Russian)
- [25] Blohm W 1999 *Proc. Intl. IWMA Conf. Economical Processing of Rod to Wire & Cable* 67–75
- [26] Gavrilin A, Moyzes B, Cherkasov A, Mel'nov K and Xiaoliang Zhang 2016 *MATEC Web of Conf.* **79** 01078 doi: 10.1051/mateconf/20167901078
- [27] Goldshtein A E, Vavilova G V and Belyankov V Yu 2015 *Russ. J. Nondestr. Test.* **51** 86–93 doi: 10.1134/S1061830915020047
- [28] 2016 *CAPAC® /FFT Capacitance measurement systems for cable production lines* (Zumbach Electronic AG, SCHWEIZ: Hauptsitz) [Electronic resource] URL: [http://www.zumbach.com/pdf/Literature\\_DE/Catalogs/CAPAC/CAPAC\\_Familie\\_CAPA.002.0002.D.pdf](http://www.zumbach.com/pdf/Literature_DE/Catalogs/CAPAC/CAPAC_Familie_CAPA.002.0002.D.pdf)
- [29] 2016 *CAPACITANCE 2000: Capacitance measuring devices for cable production lines* (Sikora AG, Germany: Headquarters) [Electronic resource] URL: [http://sikora.net/wp-content/uploads/2016/03/CAPACITANCE\\_2000\\_GB.pdf](http://sikora.net/wp-content/uploads/2016/03/CAPACITANCE_2000_GB.pdf)
- [30] Yakimov E V and Ustyugov D A 2016 *MATEC Web Conf.* **79** 01069 doi: 10.1051/mateconf/20167901069