

Steady operation of the electric drive of pipeline armature in the emergency situation at low ambient temperatures

S V Bordunov¹, V V Kuznetsov², K R Muratov³ and O Yu Zavyalova⁴

¹Director, Public Corporation Scientific – Innovation Enterprise “Echteh”, Tomsk, Russia

²Associate Professor, Omsk State Technic University, Omsk, Russia

³Associate Professor, Tyumen Industrial University, Tyumen, Russia

⁴Associate Professor, Tomsk Polytechnic University, Tomsk, Russia

E-mail: bordunov@live.ru

Abstract. This scientific work is devoted to the study of the electric drive operation of pipeline armature at low ambient temperatures. Hit of moisture into reducer and rare inclusions in operation of locking regulator are led to curdling lubricant that causes the increased wear of mechanical knots. There is a probability of freezing mechanical components; it leads to emergency situations. The problem of improving working efficiency of the electric drive of shut-off regulating armature at low ambient temperatures of the environment is solved in this work. A simulation model of the GUSAR electric drive was developed to solve this problem. Studies of the simulation model show the need to limit the torque increase rate on a drive motor shaft. The algorithm of setting of PI speed controller to obtain acceptable transient processes is suggested. Recommendations for the use of the algorithm in the microprocessor control system of electric drive are proposed. It is shown that the electric drive operation algorithm with torque increasing limitation on the motor shaft will be smoothly working off the perturbing actions that occur in pipeline armature.

1. Introduction

Nowadays an intelligent electric drive of any production mechanism, in particular shut-off regulating element, is a complex system; its mechanical and electrical parts are in constant interaction [1–5]. In general, the intellectual part of the electric drive consists of a series of printed circuit boards containing internal memory, an electric power converter, a microprocessor part, drivers and a power unit, jointed by magnetic and electrical connections together. The mechanical part of the drive device contains an inertial multimass structure with elastic mechanical bonds [6].

At present, automated control systems for electric drives (ED) provide reliable and uninterrupted operation of mechanisms in various fields of industry and technology. The capabilities of modern intelligent electric drives are determined by the parameters of the power part and the functional characteristics of the control systems [7, 8].

In the age of high technologies, the most common is an asynchronous ED with a microprocessor-based control device, through which it is possible to organize the regulation of output variables in a wide range with high speed and accuracy [9, 10].

Rare inclusions at operation of the shut-off regulating body lead to emergency operating conditions, especially at low ambient temperatures. The determining influence on the working



capacity and the ED service life has not only the power inverter and asynchronous motor, but also the whole reducer of shut-off regulating armature [11]. The freezing ED mechanical part is due to of moisture hit into reducer at low ambient temperatures and also due to curdling lubricant.

2. Research Method

At present the actual goal is to improve the stability of the asynchronous electric drive of shut-off regulating pipeline armature at low ambient temperatures [12]. The most vulnerable type of structural failure of the shut-off regulating pipeline element is the wear of the ED mechanical part at ambient temperatures below -40°C . Therefore it is expedient to look for increasing ways of the durability of working parts under conditions of increased wear. It is necessary to limit the torque on the shaft of the electric drive to achieve optimum operating characteristics at low ambient temperatures.

Studies of the GUSAR oil pipeline armatures by SPA "Sibirskiy Mashinostroitel" (Russia) are presented in this work. GUSAR electric drive with electronic control system is designed for multi-function control by pipeline armatures and is used in oil, gas, petrochemical and other industries; it is designed for a temperature range from $+20^{\circ}\text{C}$ to -60°C . Figure 1 shows the exterior of the GUSAR electric drive. The electric drive consists of electronic control unit, asynchronous motor and wave-type reducer.

Three-phase asynchronous motor with squirrel-cage rotor of low-power explosion-proof execution of DAT-156M-02 type is used in this ED. Nominal power is 0.25 kW.

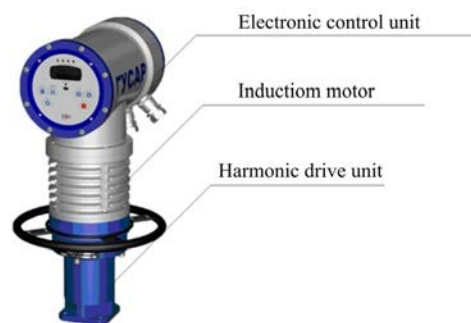

Figure 1. The exterior of the GUSAR electric drive.

Wave transmission with intermediate rolling elements is used in the reducer of the GUSAR electric drive (Figure 2); currently this transfer is in a stage of rapid development [13].

The main advantages of this transmission are a large gear ratio ($i = 80 \div 320$) at a small number of parts, improved mass-dimensional characteristics in comparison with conventional gears, high kinematic accuracy and smooth running, high output capability [14].

Figure 2a shows the profile of wave gear with intermediate rolling elements.

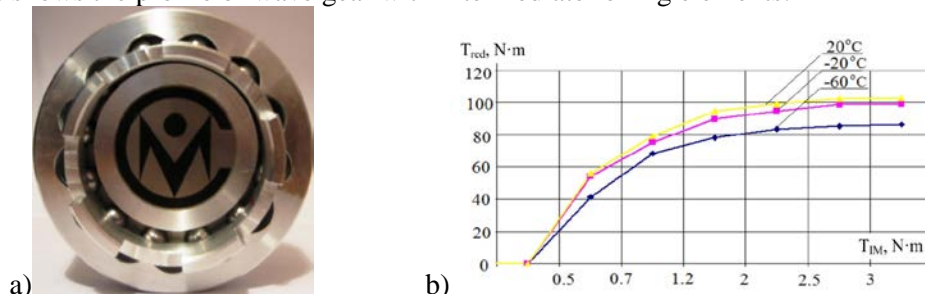

Figure 2. Wave reducer, where *a*) is profile of the wave gear with intermediate rolling elements; *b*) are wave gear characteristics.

The wave reducer has significant drawbacks. Figure 2b shows of the motor torque dependencies, namely, the dependencies of motor torque T_{IM} on the torque on wave reducer output T_{red} . These

dependencies were obtained experimentally and have a nonlinear character. It means that the moment of losses in the gear will depend on the moment on the reducer input. This nonlinearity is more manifested at values less than half the nominal torque: $T_{IMrate} = 1.7 \text{ N}\cdot\text{m}$. Also, the torque of losses increases at decreasing ambient temperature. The torque on the output link of the electric drive of pipeline armature will decrease at decreasing temperature at other equal conditions. The dependence of the moment of losses of the wave reducer on the ambient temperature and on the torque of the electric motor violates the classical principles of control systems construction for electric drives. Obligatory identification of torque at the output link of ED occurs with an error in such mechanisms; in turn, it influences on the control system. It is necessary to take into account the experimentally obtained characteristics of the wave reducer for correct operation of the electronic control unit by drive and elimination of emergency situations in the control system.

Figure 3 shows simplified functional diagram of ED. A predetermined speed signal ω_{ref} is supplied into the direction of "OPEN" or "CLOSED" to the electronic control unit. The signal p_{ref} of specified position (usually in percent) is set to put the intermediate position of the output link of the pipeline armature.

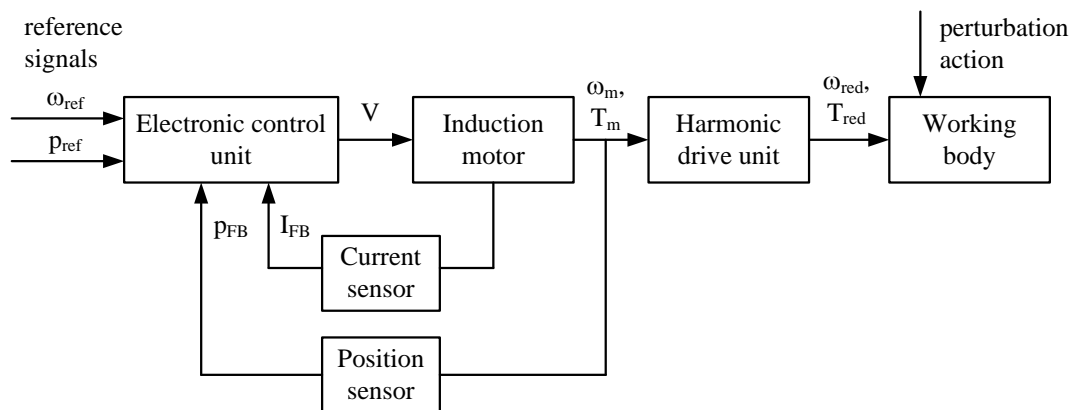

Figure 3. Functional diagram of the GUSAR electric drive.

The frequency converter of the electronic control unit generates a three-phase voltage of given frequency and amplitude V for an induction motor [15]. The electric drive control system is constructed according to the principles of vector control law [16, 17]. Feedback signals (the motor current and motor shaft position) are fed into the control unit; the motor shaft position is read in by means of absolute encoder installed on the motor shaft.

The speed required for the control system is calculated from the position signal. The motor torque T_m is converted into a torque T_{red} by means of the wave reducer, which rotates the working element. Perturbing impact is the load torque on output link of the ED. The electric drive must ensure operation at given range of load torque and stop the motor at exceeding threshold torque.

The simulation model of the GUSAR electric drive was developed by using MATLAB software (Figure 4) for electric drive control system creation of pipeline armature and study of various operating modes. This model includes an asynchronous motor with squirrel-cage rotor in two-phase coordinate system dq , a frequency converter with flow support channel and speed control channel, mechanical part, including a nonlinear dependence of losses torque of the wave reducer (Figure 2b). This simulation model allows to study of electric drive of pipeline armature in different dynamic operation modes.

3. Results and Discussion

Figure 5 shows the transient processes graphs of the electric drive at full operating cycle. The graph of the moment T is shown at the top of Figure 5, and the velocity graph ω is at the bottom of Figure 5. The operation cycle includes soft start, load surge and braking [7]. Soft start is provided with the help of power-up sensor, which forms the temp of increasing the electric drive speed. The use of power-up

sensor allows deleting beats in the mechanical part of the electric drive, which occur in the gear, couplings and other nodes containing clearances.

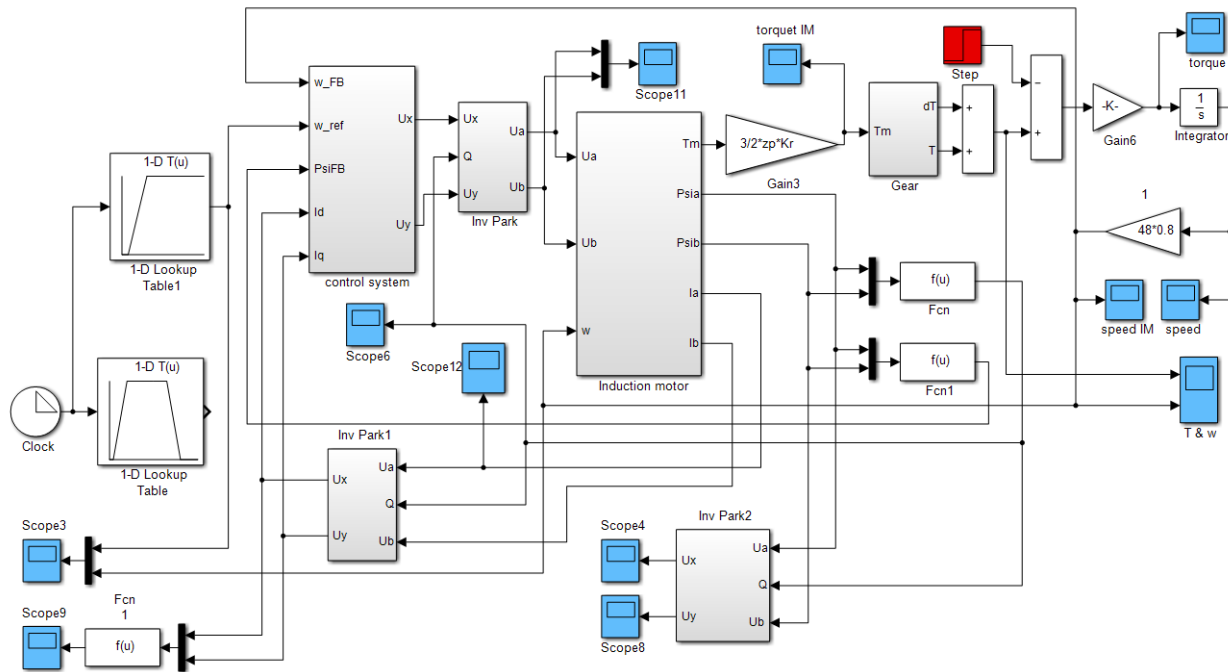

Figure 4. Simulated model of the GUSAR electric drive.

The transient processes graphs of the electric drive at load surge are shown in Figure 6. Enhanced scale of image of load surge allows making a conclusion about control system high operating speed. This is very important at the operation of pipeline armature in such modes as maintaining pressure or flow of gaseous or liquid media. However, there are operating modes and application areas of such electric drives, in which this speed can lead to emergency modes.

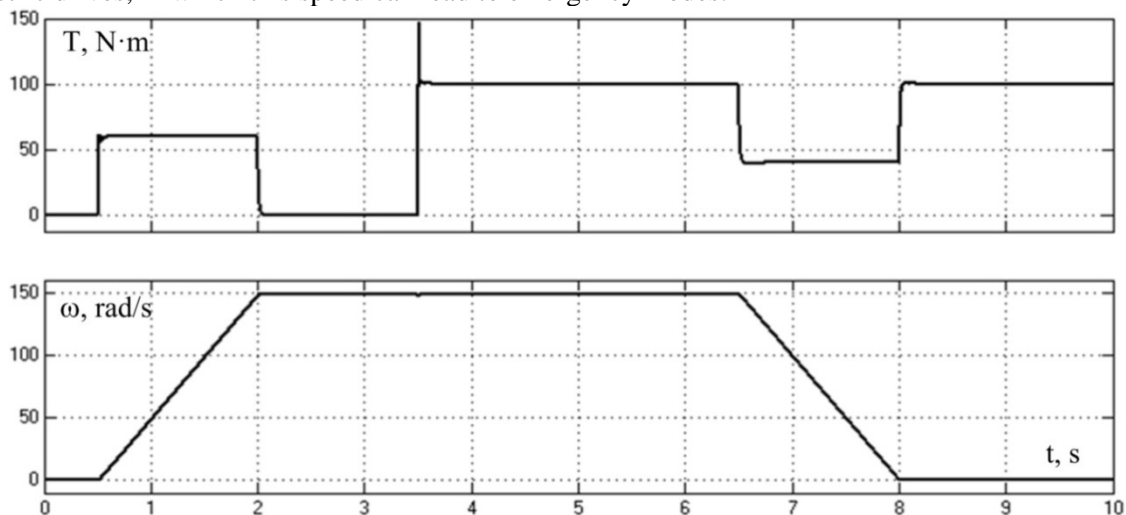

Figure 5. Transient curves of full operating cycle of the electric drive.

Such modes are connected with low ambient temperatures very often. Rare use of ED, curdling lubricant, freezing of mechanical parts of the drive lead to the fact that there is a danger of breakage of mechanical parts at sharp increasing torque on the electric motor shaft. It is necessary to increase gradually the torque in such modes; it is realized using the speed controller. A softer setting of the

speed controller will allow limiting the rate of increasing the given parameters on the torque, which is the speed controller output. In this case the decreasing drive operating speed is expected.

Figure 7 shows transient processes graphs of the electric drive at the load surge with a smooth increasing torque. It is sufficient to reduce the proportional part of the PI speed controller for this. Speed sagging at the level of 20% of the nominal value occurs in this case. The operating speed loss avoids possible emergency conditions in this situation.

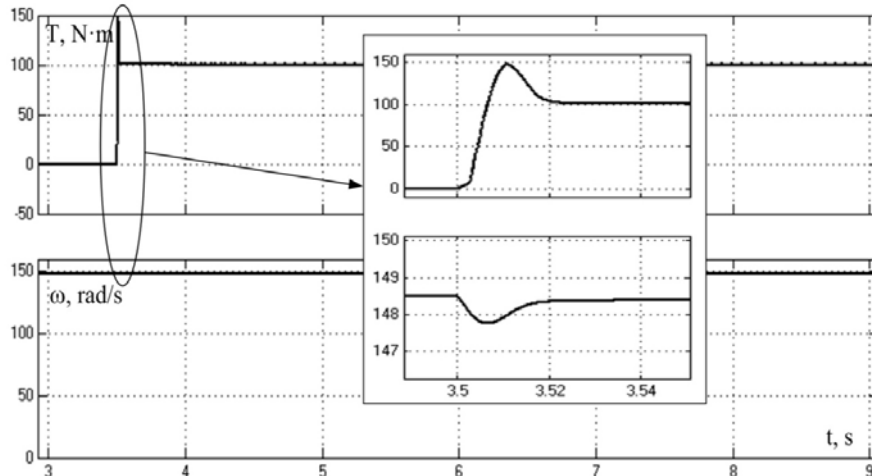

Figure 6. Transient curves of the electric drive at the load surge.

Smooth increasing the moment will allow estimating the torque on the motor shaft and making an appropriate decision by the microprocessor system. This situation was realized using a simulation model. This situation was realized using a simulation model. Figure 7 shows the results of this simulation. The maximum torque of the ED is set at level of 125 N·m. The control system monitors the torque. When this value is exceeded, the drive brakes by decreasing the given speed to zero at the normal speed controller settings. The torque is negative at the process of braking; after this it is equal to the load torque at zero speed.

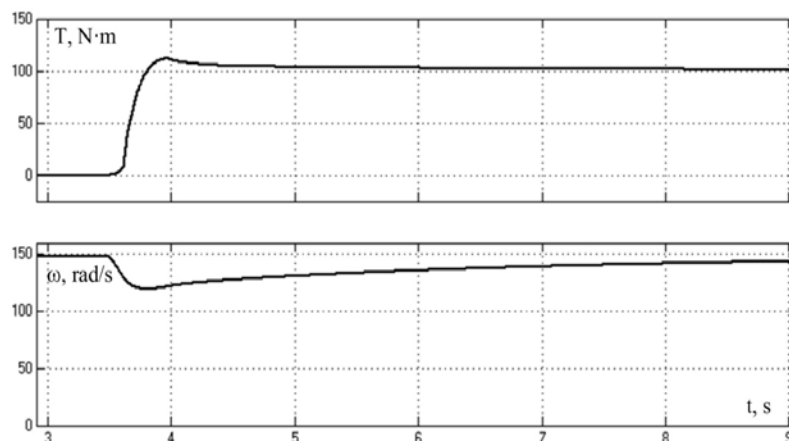

Figure 7. Transient curves of the electric drive at the load surge with a smooth increasing torque.

A milder setting of the speed controller is needed in two cases: to simulate "accident" at excess of the given torque by the user and smooth tearing off of the frozen mechanical parts at low ambient temperatures. For the second case it is necessary to base on the data of the ambient temperature and also to keep the event log (for calculating the time from the last successful start-up of the motor) at setting the PI speed controller (Figure 8).

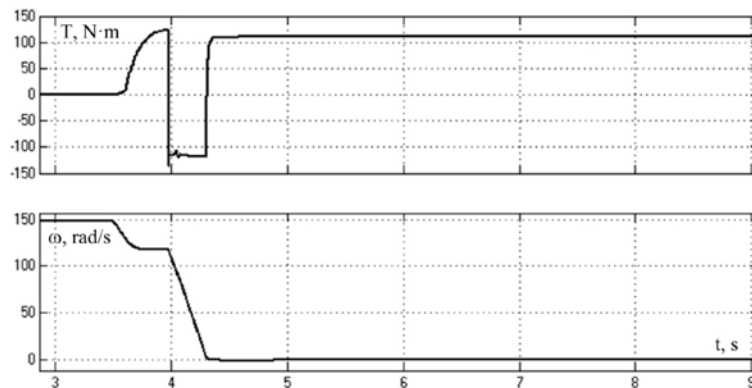

Figure 8. Transient curves of the electric drive at the load surge at disaster shutdown.

4. Conclusion

The freezing of the electric drive mechanical part due to curdling lubricant takes place at low ambient temperatures. The probability of an emergency at the dynamic modes of the electric drive is increased. Increasing sustainable operation at low temperatures is a priority task.

Experimental data show that it is necessary to limit the rate of increasing torque of the motor at dynamic conditions of operation at low ambient temperature. This limitation is proposed to be made by means of the corresponding setting of PI speed controller. The setting of the speed controller can be adapted during the operation of the device depending on the ambient temperature and on how often the drive operation is used.

References

- [1] Payuk L *et al* 2016 *MATEC Web of Conferences* **79** 01060 doi: 10.1051/mateconf/20167901060
- [2] Aristov A *et al* 2016 *J. of Physics: Conf. Ser.* **671** 012002 doi: 10.1088/1742-6596/671/1/012002
- [3] Karakulov A S 2002 *Proc. of MTT'2002* 1213755 doi: 10.1109/SPCMTT.2002.1213755
- [4] Odnokopylov I G *et al* 2017 *IOP Conf. Ser.: Mater. Sci. Eng.* **189** 012010 doi: 10.1088/1757-899X/189/1/012010
- [5] Langraf S *et al* 2017 *MATEC Web of Conferences* **102** 01026 doi: 10.1051/mateconf/201710201026
- [6] DeWall K *et al* 1997 *Motor-operated valve (MOV) actuator motor and gearbox testing* (United States) doi: 10.2172/515583
- [7] Bing D , JunMin P 2001 *Proc. of IECON'2001* 7282671 doi: 10.1109/IECON.2001.976478
- [8] Wang S *et al* 2018 *Appl Surf Sci* **428** 1070–1078 doi: 10.1016/j.apsusc.2017.09.225
- [9] Granjon P 2011 *Proc. of 8th. International Conference on Condition Monitoring and Machinery Failure Prevention Technologies* 109–119
- [10] Tosun G *et al* 2016 *Proc. of PEMC'2016* 7752055 doi: 10.1109/EPEPMC.2016.7752055
- [11] Xu L *et al* 2012 *Proc. of ISCID'2012* **2** 6406021 doi: 10.1109/ISCID.2012.248
- [12] Klueber P 1983 *IEEE T Ind Appl* **IA-19** 962–967 doi: 10.1109/TIA.1983.4504321
- [13] Tjahjowidodo T *et al* 2013 *Mechatronics* **23** 497–504 doi: 10.1016/j.mechatronics.2013.04.002
- [14] Abdelraheem S *et al* 2017 *Proc. of MEPCON'2016* 7836869 doi: 10.1109/MEPCON.2016.7836869
- [15] Pankratov V V and Kotin D A 2009 *Russ Electr Engin* **80** 651–656 doi: 10.3103/S1068371209120037
- [16] Takahashi A *et al* 2008 *Proc. of ICCAS'2008* 4694213 doi: 10.1109/ICCAS.2008.4694213
- [17] Vasendina E *et al* 2016 *IOP Conf. Ser.: Mater. Sci. Eng.* **110** 012070 doi: 10.1088/1757-899X/110/1/012070