

SOME ISSUES OF THE QUALITY CONTROL SYSTEM DEVELOPMENT FOR TELECOMMUNICATIONS SERVICES

Alexey Yurchenko¹, Tansaule Serikov², Aliya Alkina¹, Yelena Neshina^{1a}

¹National Research Tomsk Polytechnic University, 634050, Tomsk, Russia

²Karaganda State Technical University, 100000, Karaganda, Kazakhstan

Abstract. In connection with the rapid development of telecommunications technologies, the provision of communication quality parameters and its reliability are very relevant. In this regard, the new approaches to the operation and control of telecommunications networks are required which are inconceivable without an integrated approach to solving this problem and developing a control system not only for the network state, but also for the quality indicators of its operation. The idea of the work is to develop the control system that is able to determine the principles of strict monitoring over the telecommunications network of Kazakhtelecom JSC in Karaganda. The analysis of the key performance indicators of the telecommunications network showed that after the implementation of the Network Management System hardware and software complex, all values of quality indicators meet the regulatory values. It allows monitoring and controlling the telecommunications network at various levels of operation of basic and auxiliary equipment in a wide range of work.

1 Introduction

Modern telecommunications systems should have the high quality service level provided to their customers. The quality of these communication services is the main criterion for assessing the telecommunications network which is especially important for the national operator Kazakhtelecom JSC. The concept of "quality" for this operator is present throughout the technological cycles of the production organization of the communication service.

At present, in connection with the rapid development of telecommunications technologies, the provision of communication quality parameters and its reliability are very relevant. In this regard, the new approaches to the operation and control of telecommunications networks are required which are inconceivable without an integrated approach to solving this problem and developing a control system not only for the network state, but also for the quality indicators of its operation. In the search for various kinds of faults and failures that arise in modern information transmission systems, the greatest time is spent on identifying the causes that are related to the characteristics of the channels and communication lines, intra- and inter-system interactions, as well as unintentional or

^a Corresponding author: 1_neg@mail.ru

deliberate actions of personnel. The identification of specific reasons for the failures of certain communication directions is extremely important for the rapid, coordinated and complete restoration of the network. At the same time, for a qualitative solution of this problem, it is necessary to use a rather large amount of information obtained from geographically dispersed objects of the network, as well as from specially conducted measurements. Information obtained in this way is characterized not only by diversity, but also by time difference which greatly complicates its generalization and processing.

Based on information from sources [1, 2] it can be concluded that the entire cycle of information transmission within the framework of a single production process requires, as a rule, the interaction of not one but several telecommunications enterprises (divisions). Moreover, each division takes part in the process of information transmission only at a certain stage.

Therefore, at the present time the monitoring systems are increasingly used to control and diagnose the various network aspects, which make it possible to solve these problems more effectively. And although such systems cover a wide range of issues being solved by them, still many of them are characterized by a certain "specialization" and do not solve the main problem such as control and diagnosing the entire network. This is precisely why the relevance of this present work is justified. The idea of the work is to develop the control system that is able to determine the principles of strict monitoring over the telecommunications network of Kazakhtelecom JSC in Karaganda.

2 Experimental study

While analyzing the management system of the backbone telecommunications networks, it is apparent that the system is built on the basis of Tivoli Netcool product family. Tivoli Netcool is an integrated software platform used to build the Operations Support System (OSS) and Quality Control System of the services provided. The structure of the telecommunications network management system (TNMS) of Kazakh telecom JSC is presented in Figure 1.

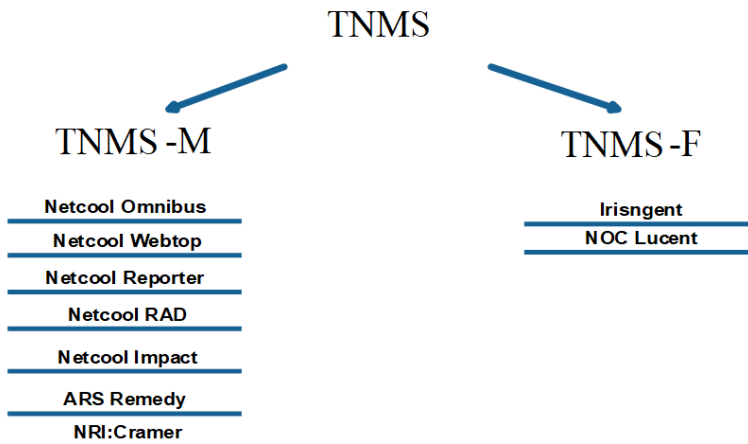

Fig. 1. Structure of the Telecommunications Network Management System (TNMS) of Kazakh telecom JSC.

The results of the network operation show that there is no control over the telecommunications network health on the network. The qualitative indicators adjusted by

the company's management are not met, and the regulatory indicators are several times lower. To achieve this goal there is a need to develop a system that will not only monitor the progress of the emergency elimination, but also prevent the occurrence of an emergency on the network. In a word, it would monitor the network and its progress of operation.

Our task is to create a hardware and software complex with the name Network Management System assigned to it, which is able to function as a quality control system in efficient interaction with NETCOOL - Problem Tickets Management System (PTMS) (REMEDY). We use a systematic approach to creating a powerful multi-level system for controlling and diagnosing the telecommunications operations. The flexibility of the system will allow controlling both one and several networks simultaneously, from tens to several thousand objects. The monitoring objects connected to the management system are integrated with Netcoolupper-level telecommunications networks management system existing in Kazakh telecom JSC through the transmission of message flows using SNMP interface. All messages must contain:

- the physical and/or logical address of the equipment on which the fault occurred;
- identifier or internal report number;
- type of report (problem/resolution/information);
- priority rank for troubleshooting (critical/minor/ major, etc.);
- date and time when the fault occurred;
- a copy of the full text of the event formed by the monitoring object;
- information on correlation of opening and closing events;
- other additional information that technicians should use to eliminate and troubleshoot the equipment faults.

The interactions of components of the Telecommunications Networks Management System (TNMS) of the branch with components of the upper-level management system:

- the emergency report from the examination system (ES) is submitted for primary processing to the SEB controller, where it is reduced to a unified form, transmitted to the database of the Network Management System server and displayed on the workplace monitors of the branch personnel;
- the processed emergency report is transmitted by the Network Management System to TNMS Netcool and displayed on the monitor of the personnel of the main telecommunications network management center; Netcool system further carries out the analysis of the alarm message on the need to create a problem ticket in the PTMS for this type of emergency;
- the problem ticket is automatically created in the PTM Sand dispatched by REMEDY SW to the workplace of the responsible division for the organization of work to eliminate the damage on the network;

Figure 2 shows the interaction pattern between the Network Management System and the upper-level management systems. It is also used the notion of loss of accuracy which is estimated by the value of the error rate or the error probability rate.

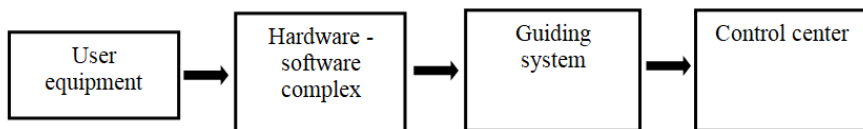

Fig. 2. Network Management System Hierarchy. Structural diagram.

The error rate R_{err} is defined as the ratio of the number of erroneously received symbols N_{err} to the total number of transmitted symbols N_{Σ} in the measurement time interval $T_{measur.}$:

$$\text{Rerr.} = \frac{\text{Nerr.}}{N_{\Sigma\text{Tmeasur.}}}$$

When the binary signals are transmitted to the DTS (digital transmission system), the error rate is numerically the same as the error probability rate $\text{Perr.} = \text{Rerr.}$ Since the digital flow transmitted through the digital line path (DLP) is always affected by distortion and interference which lead to digital errors. This means that some part of the binary symbols will not be accepted correctly: at the location "1" there may be "0" and vice versa. That is, the error probability is always different from zero $\text{Perr.} \neq 0$.

The main quality assessment of the binary information transmission over the digital linear path is accuracy. The accuracy is the degree of conformity of the received information with transmitted one. The accuracy assessment is the probability of the correct reception, equal to the ratio of the number of correctly received message symbols to the total number of transmitted symbols for a certain period of time [3].

The system is built on a hierarchical basis and ensures the collection and processing of information, and then redirects it to the server that performs its final processing and analysis. The flexibility of the system allows it to be combined with any telecommunications equipment and specialized devices, and at the same time their own diagnostic capabilities can be used. The measurement monitoring elements are connected through an intermediate SEB server which perform the intermediate function of collecting and processing information and transferring it to a central server. If necessary, there is the transmission of corrective and control signals or in another word of effects to the objects from the SEB server. The whole management process happens in real time.

In addition to telecommunications equipment, Network Management System is able to manage any devices, including, for example, the contact elements of safety-alarm devices or SNMP. This means that it is possible to control any devices in the network which allows expanding the range of services provided. The information about the state of objects can be additionally sent via SMS, fax, e-mail or SNMP message [4].

Network Management System allows optimizing the amount of information output to the monitors of the dispatcher or operator, provided that the logical linking of events is logically removed at one of the objects. For example, to ignore the repeated voice messages caused by the failure of the automatic telephone exchange (ATE) and process them combining in one message about the failure of the ATE. The reports of events and faults are easily created using the interface and menus, while the issuance of reports can be programmed or executed on request to the server. If necessary, the summary of important events and emergencies can be received by e-mail or fax. The event filtering allows the operator to focus on important events and automatically configure the system's response to certain events.

Network Management System provides the visualization of processed information and data about the state of objects, presents their logic scheme or other scheme up to topographic one with the possibility of detailing to equipment or port elements which allows effectively monitoring the state of the object. It is possible to automatically prioritize the events. In the absence of an appropriate response the additional messages about important failures are made taking into account the status, importance and situation.

Types of controlled equipment using the network management system are shown in Figure 3.

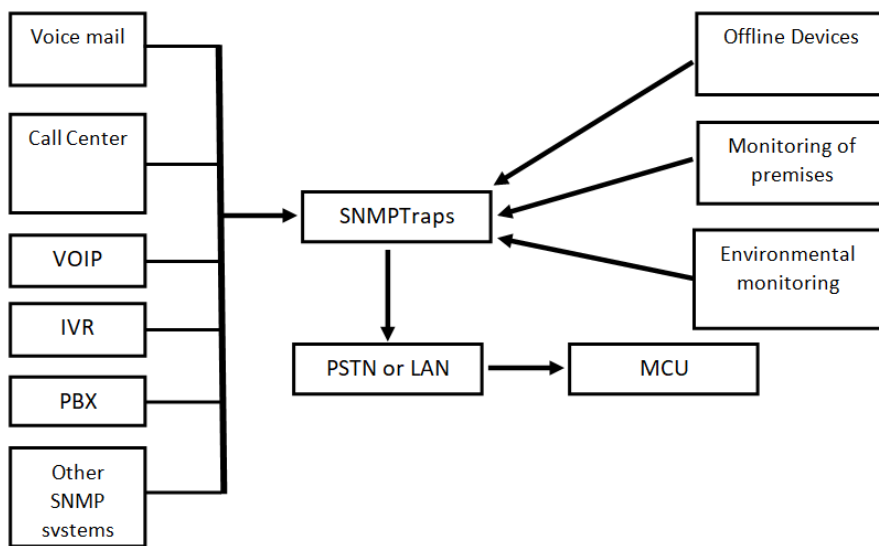

Fig. 3. Types of monitored equipment using Network Management System.

In the absence of staff reaction to critical situations and events, the priority of messages will be increased by sending them to the management units, for example, the chief engineer.

3 Developed methods

The reliability of the operation of our system is provided by different methods. For example, the standby power supply from the storage batteries ensures the uninterrupted operation and collection of information on the server after disconnecting the mains supply for several other hours accumulating information about the events. An important point is the hardware and software complex that allows processing information on the central server and making the necessary hardware settings, as well as performing the corrective operations. The collection of information about events and notification happens in real time with access to the objects serviced. The discrepancy between the information received and transmitted can be caused by the following reasons:

- 1) imperfection of methods of converting the transmitted message into a signal;
- 2) imperfection of signal transmission and reception methods;
- 3) imperfection of the methods of converting the received signal into a message;
- 4) features of signal propagation along the communication line;
- 5) insufficient noise-immunity of the signal.

The analysis of the result of the implemented software and hardware complex can be the reduction of key indicators. The control system with Network Management System was implemented in the network of Karaganda Regional Directorate of Telecommunications of the branch of Kazakh telecom JSC in early 2015. The results of the work after the implementation of the Network Management System hardware and software complex for the first half of 2016 are given in Table 1 [4, 5]. The interaction template: the network management system - NETCOOL - PTMS (REMEDY) is shown in Figure 4.

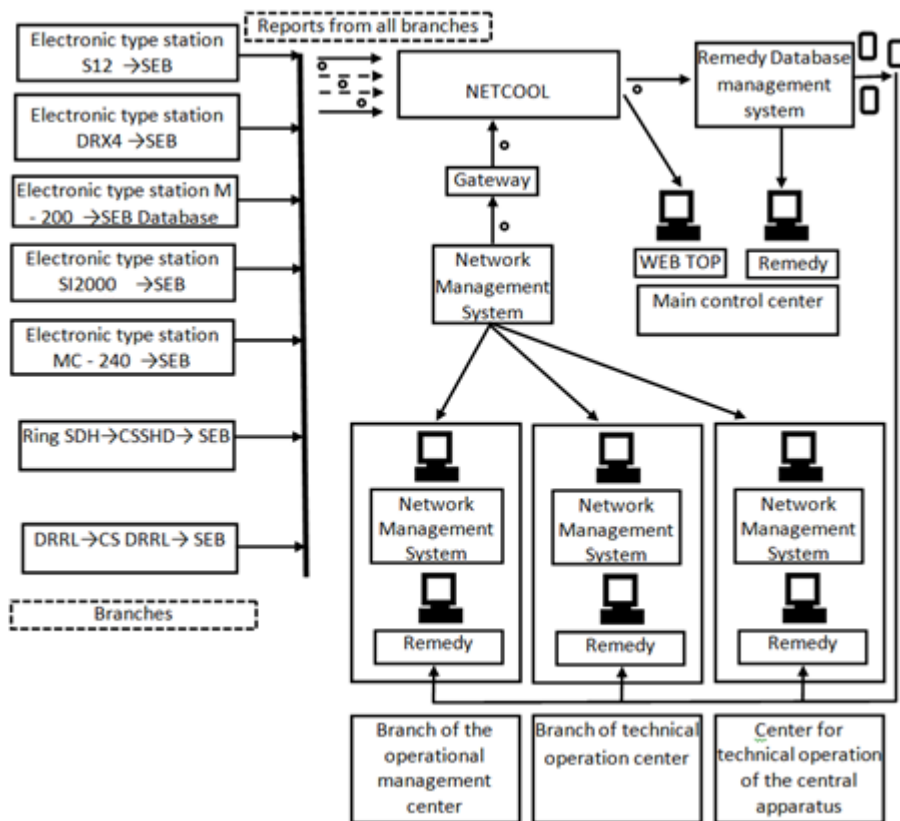

Fig. 4. Interaction Pattern: Network Management System - NETCOOL – PTMS (REMEDY).

While comparing the main indicators before and after the implementation of the Network Management System hardware and software complex concerning regulatory indicators adjusted by the company's management, it is possible to visually analyze the information (Figure 5, 6). Figure 5 shows one of the main indicators of the quality of the network; this is the network availability factor, which clearly shows the result of the Network Management System hardware and software complex.

Table 1. Main Quality Indicators.

Indicators	Time required to identify the fault of the automatic telephone exchange, h	Time required to eliminate the fault of the automatic telephone exchange, h	Time required to identify the network fault, h	Time required to eliminate the network fault, h	Network availability factor, %	Percent indicators for establishing connections, %
Regulatory	3	3	3	4	99	50
Actual	1.3	2.1	0.5	3.2	99.97	56

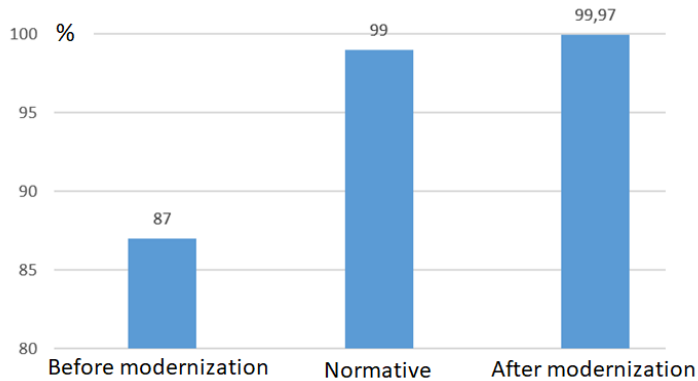

Fig. 5. Quality indicators for network availability factor.

Figure 6 shows a percent graph of the connection of network subscribers of Kazakh telecom JSC in Karaganda through communication channels. According to the results of the data, as a result of the work of the company's branch, it was not only completed, but was exceeded the adjusted standard by 22% after the implementation of the Network Management System hardware and software complex.

The analysis of the key performance indicators of the telecommunications network showed that after the implementation of the Network Management System hardware and software complex, all values of quality indicators meet the regulatory values. It allows monitoring and controlling the telecommunications network at various levels of operation of basic and auxiliary equipment in a wide range of work. The use of the Network Management System hardware and software complex when interacting with NETCOOL - PTMS (REMEDY) can be considered as a system approach to the creation of a powerful multi-level system for monitoring and diagnosing the telecommunications operations.

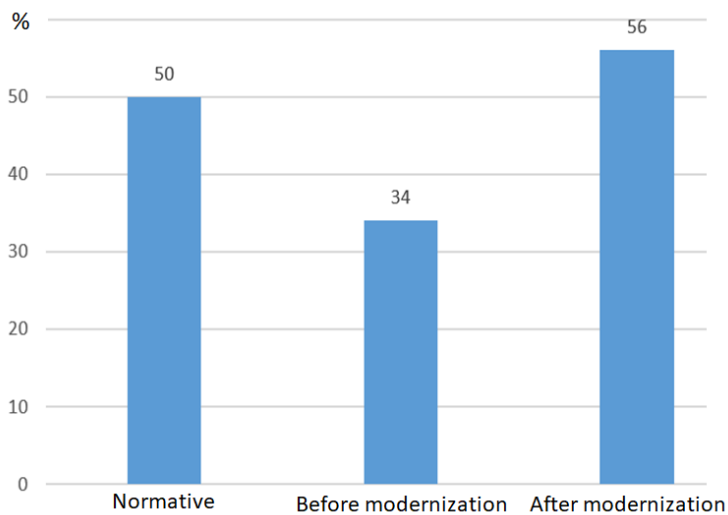

Fig. 6. Graph of the percentage ratio of connection of network subscribers of Kazakh telecom JSC in Karaganda through communication channels.

4 Conclusion

The flexibility of the system will allow controlling both one and several networks simultaneously, from tens to several thousand objects. The Network Management System hardware and software complex includes a central server and SEB control buffers. Today it is already impossible to manually and locally manage the network and at the same time to monitor all parameters, quickly correct errors and implement new services, against the background of increasing speed and the implementation of all new technologies and services. The use of the Network Management System hardware and software complex will allow ensuring in practice high level of control, efficiency of operation and development of telecommunications networks; and the implementation of a unified control system will reduce material costs. The second positive moment will be the concentration of specialists on the minimum number of objects, and not on each object which can be several thousand. This is very effective from the economic positions of costs and it solves an important problem of highly qualified personnel, since the system allows monitoring the objects remotely and thus the need for the presence of specialists at the sites is eliminated.

References

- [1] A.B. Ivanov, *Kontrol' sootvetstviia v telekommunikatsiakh i sviazi* (Kompaniia Sairus Sisteme, Moscow, 2000)
- [2] M.P. Matekin, D.S. Mironov, A.K. Skuratov, Trudy X Vserossiiskoi nauchno-metodicheskoi konferentsii "Telematika-2003", 253 (2003)
- [3] T.G. Serikov, M.Z. Yakubova, A.D. Mekhtiev, V.V. Yugay, A.K. Muratova, V.P. Razinkin, A.V. Okhorzina, A.V. Yurchenko, A.D. Alkina, IFOST 2016, 510 (2017)
- [4] M.Z. Yakubova, A.D. Mekhtiyev, T. G. Serikov, A.D. Alkina, A.V. Yurchenko, E.G. Neshina, X International IEEE Scientific and Technical Conference "Dynamics of Systems, Mechanisms and Machines" (Dynamics), 315 (2016)
- [5] S. Shipilov, R. Satarov, I.Fedyanin, E. Balzovsky, V.Yakubov. MATEC Web of Conferences 7 01079 (2016) doi: 10.1051/mateconf/201679010