

Grounding systems for power supply facilities

Vladimir Konusarov^{1,*}, and Ekaterina Tarasova²

¹National Research Tomsk Polytechnic University, 634050 Tomsk, Russia

Abstract This study aims to define some recommendations for choice of grounding system type for power supply facility. Operating modes of 0.4 kV networks approved by International Electrotechnical Commission (IEC) were considered and their advantages and disadvantages were identified. The comparison criteria were based on the conditions of human safety from electric shock in the breakdown of insulation on the body of electrical equipment, possibilities of expanding the network and uninterruptible power supply. The real application of the neutral modes and the possibility of installing protective devices were also taken into account. All the recommendations made is planned to apply for the modernization of the urban networks and the calculation of the earthing arrangement by using special software.

1 Introduction

Grounding is one of the most important technological methods used to protect against an electrical shock. Reliable protection of power supply objects from various types of over-voltage requires the creation of an effective system for grounding electrical installations and equalizing the potentials on them. This study work is devoted to systems of grounding of elements of city distributive networks. In these networks, recently there have been increasing trends to the separation of protective and zero conductors, this transition makes it possible to protect against impulse over voltages, as well as it is more reliable in terms of electrical safety. [1] In addition to the grounding and equalizing the potentials, a significant influence is given to protective devices whose switching circuits depend on the mode of operation of the neutrals. We consider in more detail the earthing methods of urban distribution networks of 0.4 kV and supply substation 10/0.4 kV.

2.1 Neutral operation modes in 0.4 kV networks

Technical features of electrical installations and their power supply networks cause the application of various types of grounding systems. In this case type of grounding system is a position relative to the ground of a substation's neutral and electrical installations' neutral. IEC provides application of three neutrals' and a conductive parts' work modes.

* Corresponding author: Konusarov@mail.ru

Table 1. Modes of neutral's work.

Type of grounding system	Description
TN	Substation's neutral is solidly grounded. Electrical installations cases are connected to neutral conductor.
TT	Substation's neutral and Electrical installations cases' neutrals are solidly grounded and unconnected.
IT	Substation's neutral is isolated. Electrical installations cases' neutrals are dead grounded.

The neutral grounding mode TN is divided into 3 types, table 2.

Table 2. Types of grounding modes of TN neutrals.

Type of grounding system	Description
TN-C	Zero protective and neutral conductors are united in one conductor throughout it's all length
TN-S	Zero protective and neutral conductors are separated
TN-C-S	Zero protective and neutral conductors are united at the head, and then separated

The method of grounding the neutral largely determines:

- Conditions of safety in electrical networks, protection from the risk of electric shock;
- Method of limiting overvoltage;
- Electromagnetic compatibility in normal and emergency modes;
- Fire safety;
- Currents with single-phase faults, damageability, selection of electrical equipment;
- Continuity of power supply;
- Network design and operation.

It will be noted the advantages and disadvantages of the existing neutral operation modes in 0.4 kV networks, having chosen the criteria listed above as comparison criteria.

2.1.1 TN-C grid

Networks with this neutral mode of operation are most common in Russia. The network diagram is shown in Fig. 1.

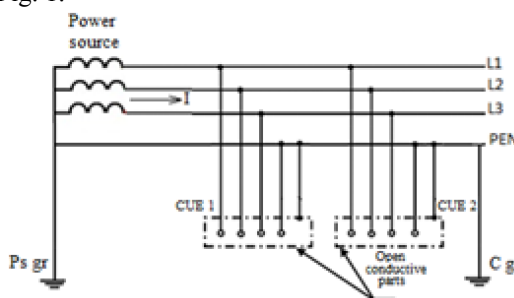

Fig. 1 Diagram of an electrical network with TN-C neutral grounding system.

Electrical safety with indirect contact in this case is provided by switching off the fuse or circuit breaker. If the fault is remote from the source, its elimination time increases in this case the danger of electric shock to persons increases. To ensure electrical safety, short-circuit protection must be switched off within a time less than 0,2 s, which is provided with fuses and circuit breakers only in case

$$I_{\text{fault}} = (5-6) I_{\text{nom}} \tag{1}$$

Thus, with an indirect contact in remote faults, the TN-C neutral is not safe. It should be noted that designing this type of networks demands to measure or calculate the resistances of all connections and phase-zero loops for their protection settings, and when the network parameters are changing, it is necessary to do a recalculation to ensure the reliability of the protections.

The biggest disadvantage of the TN-C network is the inability of the residual current devices (RCD) to function [2]. The fire safety of this network is low. This is due to the significant currents of single-phase fault and as mentioned above with the weak sensitivity of the protection for remote damage. For TN-C networks, the appearance of electromagnetic disturbances is typical, even in normal mode a voltage drop occurs in the zero wire [2].

This grounding system was used in the Soviet Union and now it can be found in houses belonging to the old buildings. Today it is also used in the networks of street lighting, where the degree of risk is minimal.

2.1.2 TN-S grid

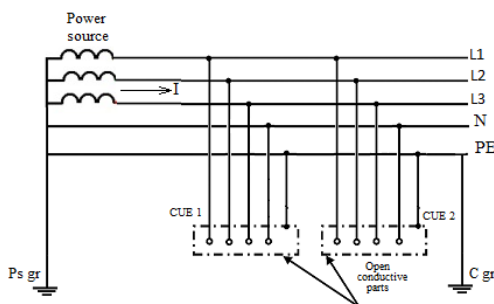

Fig. 2 Diagram of an electrical network with TN-S neutral grounding system.

Separation of the working and protective zero conductors do not provide electrical safety with an indirect contact similar to the TN-C network. The advantage of this network is the ability to use an RCD, it enhances the electrical network. Fire safety of TN-S network, due to the action of RCD is significantly higher in comparison with the TN-C networks. With regard to the continuity of the electricity supply network are similar.

In terms of designing, configuring and maintaining protection, TN-S networks do not have significant advantages over TN-C networks, besides they are significantly more expensive due to the installation of an RCD and the presence of a fifth wire. This grounding TN-S first appeared in Europe and is still used there. In Russia TN-S networks are used in the construction of multi-storey buildings.

2.1.3 TN-C-S grid

The TN-C-S network is a combination of TN-C and TN-S networks. The TN-C-S network is characterized by all the advantages and disadvantages noted above of the two previous networks. The TN-C-S grounding system is used in urban buildings; the conductors are separated in the basement of the building and running separately in the rises.

2.1.4 TT grid

The TT network is characterized by the fact that the neutral of the power source and the conductive parts of the electrical receivers are dead-earth grounded, through unconnected conductors, the circuit is shown in Fig. 4.

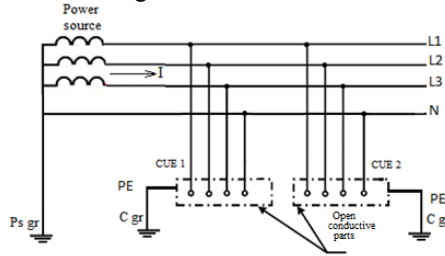

Fig. 4 Diagram of an electrical network with TT neutral grounding system.

With regard to the electrical network, the single-phase fault on the conductive body make the voltage on it determined from the ratio of the grounding resistor of supply substation and local grounding.

$$\frac{U_{fault}}{U_{instulation\ body}} = \frac{R_{substation}}{R_{local\ grounding}} \quad (2)$$

TT grounding system does not provide safety against indirect contact, so the use of RCD is necessary. Fire safety of networks of this type is higher than in networks TN-C. This is due to the lower values of the single-phase fault current and the use of an RCD. Uninterrupted power supply is not ensured. Electromagnetic disturbances are much lower; the amount of damage in the emergency mode is insignificant. [3]

In terms of design, the use of an RCD eliminates the problem of limiting the length of the PE conductor, there is no need to know the impedance of the phase-zero loop, it is possible to expand the network without recalculation of short-circuit currents. TT networks are widespread in rural areas, because of poor quality of power transmission line supports; they are also used in private buildings and in urban conditions to electrify temporary consumers.

2.1.5 IT grid

The IT network, in other words, can be called a network with isolated neutral. The scheme of the grounding system of the IT network is shown in Fig. 5.

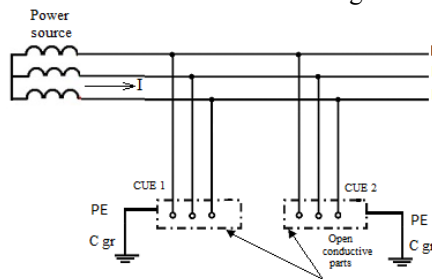

Fig. 5 Diagram of an electrical network with IT neutral grounding system.

IT networks are most electrically safe; voltage with indirect contact is practically nonexistent. Fire these networks as compared to the one discussed above is much higher; it is once again connected with small values of the fault current. IT networks are characterized

by uninterrupted operation, single-phase fault to ground or conductive equipment housing does not require immediate shutdown.

It should be noted that during the operation of the network, difficulties may occur, related to the location of the fault. Today they are widely used in dangerous industries, where electrical and fire safety is very important. Also, IT networks are often used in the construction of private houses.

3 Recommendations for choosing the type of grid

The following recommendations for choosing type of grid can be made:

As recommendations for choosing a network, the following conclusions can be drawn:

1. TN-S and TN-C-S networks are characterized by a low level of electrical safety, fire safety and significant electromagnetic disturbances.
2. TN-S networks can be recommended for selection in the case it's not planning to change it.
3. TT networks should be used to supply temporary or variable electrical installations.
4. IT networks are recommended to use, if it's absolutely necessary to ensure uninterrupted power supply.

4 Conclusion

Each of the above modes of neutral grounding is not universal. Therefore, designing a network should be based on advantages and disadvantages. It's also should be carried out a technical and economical comparison and make a choice in favor of a certain grounding regime.

There are also cases of combined use of networks, for example, when a part of consumers are powered from the TN-S network, and the other part is connected via a separation transformer to the IT network.

References

1. A.V. Kabyshev, *Lightning protection of electrical installation systems* (TPU, Tomsk, 2006) [in Russian]
2. Rules of Electrical Facilities Maintenance (RF Ministry of Energy, 2003) [in Russian]
3. S.V. Petukhov, S.V. Butakov, V.V. Radyushin, *Calculation of the grounding device* (MSU, Arkhangelsk, 2011) [in Russian]