

Open Research Online

The Open University's repository of research publications and other research outputs

The role of error factors in teaching

Thesis

How to cite:

Pickthorne, Brian (1979). The role of error factors in teaching. PhD thesis The Open University.

For guidance on citations see [FAQs](#).

© 1978 The Author

Version: Version of Record

Copyright and Moral Rights for the articles on this site are retained by the individual authors and/or other copyright owners. For more information on Open Research Online's [data policy](#) on reuse of materials please consult the policies page.

oro.open.ac.uk

31 0143129 4

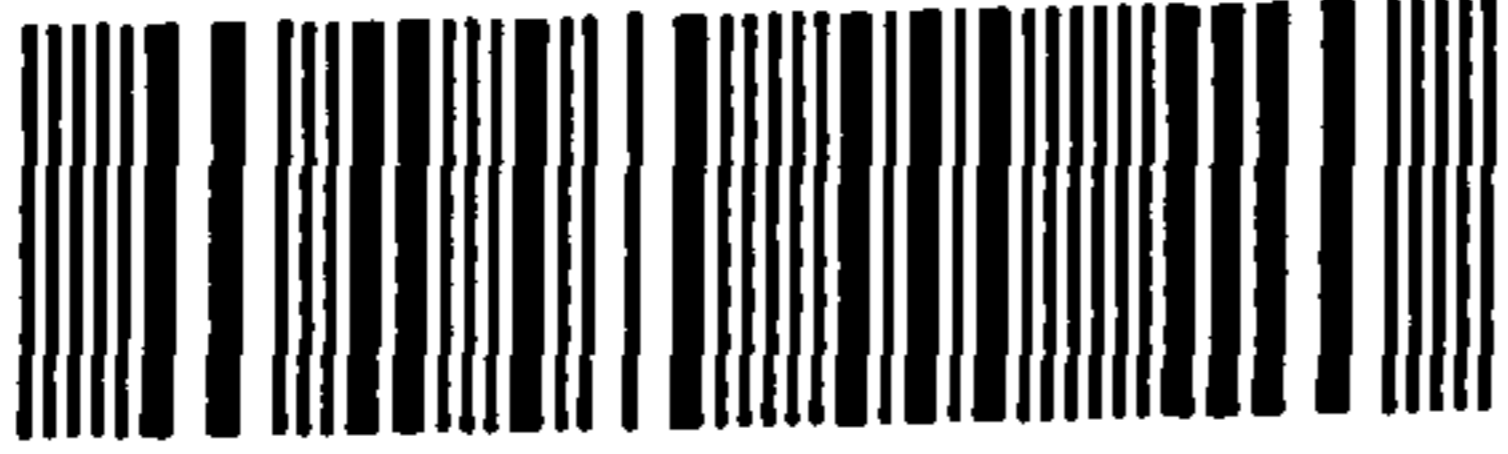

D 50376/84

UNRESTRICTED

THE ROLE OF ERROR FACTORS IN TEACHING

BRIAN PICKTHORNE

Submitted for the degree of Doctor of Philosophy

Open University
INSTITUTE OF EDUCATIONAL TECHNOLOGY

1978

Author's number: HDC 7308

Date of submission: 10-2-1978

Date of award: 1-12-1979

15th February, 1984

This is to confirm that I am willing for my thesis to be made available to readers and photocopied, subject to the descretion of the librarian.

B. Pickthorne.

B. Pickthorne Dr.

The Open University,
Higher Degrees Office
20 FEB 1984
Ack
Pass to
Disposal

ABSTRACT

The role of Error Factors in teaching

This thesis describes a wide-ranging enquiry into the nature, identification and treatment of pupil error. It takes, as its main point of departure, the work of Harlow on the role of 'error factors' in learning and it was undertaken in the belief that educators could considerably enhance the effectiveness of their teaching by making more insightful appraisals of the learning obstacles, (or error factors) of their pupils. Harlow first introduced the concept of error factors following his research into 'learning set' formation. Lewis and Pask subsequently incorporated Harlow's ideas in their own work, and laid particular stress on the significance of error factors which give rise to whole classes of errors.

The concept of error factors and the role of error factors in teaching, is examined in this thesis in both psychological and philosophical terms, because the two approaches are mutually illuminating. Despite scant literature in this sphere the entire topic is opened up to systematic examination. Hypotheses are presented concerning the role and nature of error factors, and novel strategies are proposed for treating them. A special diagnostic framework for error factors has been formulated, and its effectiveness investigated in a series of Case Studies and pilot experiments, culminating in a major experimental investigation concerning the overall role of error factors in teaching. Strategies for error factor prediction and prevention are presented and examined, including the use of algorithms. Major consideration is given to the exploitation of error factors as powerful tools to enhance learning. There is a detailed theoretical discussion at each stage, so that the full significance of the findings can be assessed. Inferences concerning the role of error factors in teaching are examined in conjunction with methodological and other implications arising from the experimental findings. A number of weaknesses of current teaching strategies are identified, and the thesis concludes with various speculations (e.g. to do with the use of computer assisted instruction in this context) which have been prompted by this investigation.

ACKNOWLEDGEMENTS

This investigation has been a major undertaking and without the advice, assistance and stimulation which was provided by the following it would not have been successful. Foremost in each of the above respects is Professor B.N. Lewis, who has also proved to be an inspiring supervisor. My sincere thanks must be given to Professor G. Pask (Brunel University) for all his help, advice and interest. I would also like to express my gratitude to Professor M. Hussey (O.U. Faculty of Technology) for all his useful ideas and assistance during this investigation.

There is a great debt of gratitude owed to the staff of the University of Birmingham School of Education and the Wolverhampton Polytechnic Faculty of Technical Education. Similarly, to the staff and students of North Worcestershire College I wish to express my thanks for much valuable assistance and for the provision of considerable facilities for this research. It is also essential that my appreciation is expressed to many of the staff of the Open University

Institute of Educational Technology, who have provided constant help and advice.

This undertaking has demanded much technical and secretarial support, which I very gratefully acknowledge. Furthermore, my grateful thanks must be given to my wife who, in spite of the demands of her own research, has given me considerable help and support. Finally, I must remember my grandfather, the late Mr. E. Carr, who initiated my deep interest in learning.

CONTENTS

| | Page No. |
|--|----------|
| PERSONAL FOREWORD | -i- |
| | |
| <u>CHAPTER ONE</u> BACKGROUND & INTRODUCTION | |
| Introduction | 1 |
| Definitions and Comments on EFs | 2 |
| EFs in the classroom | 4 |
| Literature concerning EFs | 5 |
| Programmed learning and EFs | 5 |
| Literature concerning EFs and language learning | 15 |
| Errorless learning | 18 |
| Literature concerning the philosophical aspects of error | 19 |
| Hermeneutics | 21 |
| Further philosophical factors | 22 |
| Aims and objectives for investigation | 24 |
| Plan of study | 26 |
| Summary and conclusions | 29 |
| | |
| <u>CHAPTER TWO</u> A DETAILED EXAMINATION OF EFs | |
| Introduction | 32 |
| Case 1 | 32 |
| Case 2 | 32 |
| Means of identifying EFs | 35 |
| Preliminary techniques for EF rectification | 38 |
| The causes of EFs and their exploitation | 42 |
| EF prevention | 46 |
| Basic rules concerning EFs | 50 |
| Strategies for EF correction | 54 |
| Simplification procedures | 55 |
| Types of EFs | 56 |
| Errors in reasoning | 63 |
| EF generators | 65 |
| Summary | 69 |
| | |
| <u>CHAPTER THREE</u> STRATEGIES FOR TREATING EFS AND A DETAILED PILOT EXPERIMENT | |
| Introduction | 71 |
| Preliminary strategies for EF identification | 73 |
| EF classification | 78 |
| EF classification networks and criteria | 84 |

| | Page No. |
|--|----------|
| Pilot experiment | 91 |
| Experimental method | 94 |
| Results of diagnostic tests | 104 |
| Summary and conclusions | 111 |
| | |
| <u>CHAPTER FOUR</u> A MAJOR EXPERIMENTAL INVESTIGATION OF THE ROLE OF EFS IN TEACHING | |
| Introduction | 114 |
| Basic design of experiment | 116 |
| Outline of basic EF treatment criteria | 119 |
| Diagnostic framework | 127 |
| Experiment | 129 |
| Discussion of results | 145 |
| Extracts from 'teaching log' | 158 |
| Summary and conclusions | 162 |
| | |
| <u>CHAPTER FIVE</u> SUMMARY CONCLUSIONS AND ASSESSMENT OF FUTURE DIRECTIONS OF RESEARCH | |
| Introduction | 166 |
| Conclusions regarding EF diagnostic framework | 168 |
| EF prediction | 172 |
| Conclusions regarding EF generators | 175 |
| General conclusions on EF rectification and exploitation | 177 |
| EF prevention | 182 |
| Implications of student and teacher attitudes to EFs | 183 |
| Methodological implications | 185 |
| General implications of investigation of research | 187 |
| Concluding remarks | 191 |
| Assessment of future directions of research | 194 |
| | |
| <u>APPENDIX 1</u> | 199 |
| | |
| <u>APPENDIX 2</u> | 200 |
| | |
| <u>APPENDIX 3</u> | 202 |
| | |
| <u>APPENDIX 4</u> | 204 |
| | |
| <u>APPENDIX 5</u> | 207 |
| | |
| <u>BIBLIOGRAPHY</u> | 211 |

A PERSONAL FOREWORD

Every experienced teacher knows that teaching is difficult. However, surprisingly little has been written on the question of why this should be so. There is of course no shortage of opinions on the matter. If we ask practising teachers to tell us why teaching is difficult, we are likely to hear that pupils are dull, lazy, inattentive, and the like. If we ask pupils to tell us why teaching is difficult, they may well make the same sorts of remarks about their teachers. Variations on this theme might suggest that teachers are too often out of touch with pupil needs, and that the subject matter being taught is irrelevant to real-life affairs, and so on.

Opinions of this kind may well contain more than a grain of truth but they surely fail to get to the heart of the matter. The trouble is that, even if we have competent and highly motivated teachers addressing competent and highly motivated pupils, teaching is still difficult. Teaching, it seems, has certain intrinsic difficulties. This being so, the property of being dull or lazy or inattentive or whatever is not exactly a root cause of a pupil's failure to learn. It is, rather, an exacerbating factor. Being lazy or inattentive is a reason for stumbling at some hurdle, but it is not the hurdle itself.

If a pupil really is dull or lazy etc., then this is something that a teacher obviously ought to know about, and take into consideration as he teaches. More generally, it is manifestly desirable to enquire into the abilities and character traits of the pupils being taught. This much is not under dispute. What is being suggested, however, is that there are advantages to be gained in mounting a more abstract enquiry into difficulty, per se. And this is what the present thesis is all about.

Pupils make errors, and they make the further error of failing to recognise that they are making errors. Teachers also make errors and, like the rest of the human race, they also fail to recognise that they are making errors. Under standard classroom conditions, this state of affairs can give rise to a sort of Comedy of Errors in which the hopes of all parties are alternately raised and dashed. A teacher will ask a question, get a correct answer, and believe that he is successfully 'getting through' to his pupils. He will then ask another question, get a wrong answer, and wonder whether he ought to return to 'square one'. The situation is made even more confusing if we consider the possibility of a pupil giving a correct answer for a wrong reason. When this happens, errors can go undetected for a considerable time. Worse, they may become deeply entrenched through failing to be detected and

corrected at a sufficiently early stage.

The problem is a ubiquitous one, and is by no means restricted to classroom situations. It is the problem of how errors come to be made, and what can be done to detect and eradicate errors that are made. A critical ancillary problem is that of elucidating the conditions under which people are likely to notice, or fail to notice, that they are doing things wrong. In the field of scientific research, for example, there is an urgent need for better error-detection procedures. The need is to discover one's mistakes - one's erroneous assumptions, for example - sooner, rather than later. From a psychological point of view, Man's notion of error would seem to have its origin in the experience of failure. We attempt to do something, we are less successful than we hoped, and we come to recognise that we must have done something wrong. In this very general sense, everybody knows what errors are. In an achievement-orientated society, almost all of us live error-ridden lives. Again and again, from childhood onward, we have forcibly drawn to our attention the fact that we are doing things wrong.

Since errors are a common experience in our daily lives, the reader of this thesis should not have too much difficulty in following the general drift of the arguments that will be presented. It may come as a surprise, however, to be told that errors, per se, can usefully be theorised about. In this connection, it may be worth noting that many people would have said the same thing, a hundred years ago, about learning. A hundred years ago, most teachers would have been highly skeptical of the claim that learning might usefully be subjected to detailed scientific investigation. After all, they were the experts in teaching and learning. What could a theorist possibly come up with that they did not already take into account, in their day-by-day teaching activities?

In the course of my enquiries into the nature and identification and treatment of student error, I have come across this skeptical attitude again and again. Teachers have assured me that every teacher 'worth his salt' automatically keeps a weather-eye open for mistakes that his pupils might be making. What could a theorist on the subject of error possibly add to the repertoire of an experienced practising teacher? This thesis is a first tentative answer to this legitimately skeptical question. One of its main objectives is to make out a case for the systematic investigation of error and error phenomena. If the reader emerges from this thesis with a conviction that errors can be usefully subjected to scientific enquiry, he will have acquired a point of view which is not at all common at the present time. Nowadays, very few people doubt the usefulness of studying learning

in a scientific way. The claim that is being made here is that, if the ideas in this thesis are diligently pursued, it will take only a few years to convince people that errors are similarly worth studying.

All teaching has both a prescriptive and proscriptive aspect. With regard to "facts", there is the business of telling pupils what is the case, and what is not the case. With regard to "procedures", there is the business of telling pupils what to do, and what not to do. There are grounds for asserting that the proscriptive aspect has been somewhat neglected. In their eagerness to tell pupils what is the case, and in their eagerness to tell pupils what to do, teachers fail to dwell, with sufficient care and sensitivity, on the pitfalls that need to be avoided. The tendency is to say to pupils, "Accept this, and do that, and you won't get into trouble..." The alternative is to say, "These are the hazards, and this is why I am telling you to do this and avoid that ...". As I shall try to show, the latter alternative induces greater error-sensitivity on the part of pupils, although it is not obviously consonant with certain Behaviourist principles to do with the maximising of positive reinforcement.

In many walks of life, the avoidance of critical errors is almost the only thing that matters. For example, it is commonly asserted that successful managers come 'in all shapes and sizes'. The implication seems to be that successful managers do not necessarily have anything in common. Against this view, it might be argued that all successful managers have learned to avoid certain easy-to-fall-into pitfalls. They are homogeneous with respect to the errors that they have learned to avoid.

A great deal of Eastern Teaching accords with this view. In India in particular, there is a long tradition of giving 'Not this, not that' advice. The Indian Guru is not concerned with telling people how to live. He is concerned with alerting people to hazards. Providing the Errors of Life are avoided, people should be free to choose their own path... .

Aphoristically, it might be said that Error is that which brings about its own Nemesis. Behaviour is perceived as errorful insofar as it is perceived as self-frustrating. If we do something wrong, but get the result that we desire, there is a high probability that our wrong behaviour will not be recognised as erroneous. This observation is especially pertinent in the realm of everyday human affairs (e.g. in cases of matrimonial strife or industrial unrest). It is less pertinent in cases for which publically agreed rules of procedure are available. For example, we can say quite unequivocally that a certain mathematical operation, or a certain manipulation of mechanical equipment, is wrong. Mathematical systems and mechanical artefacts are

designed to obey certain rules. There are agreed criteria of correctness and, with respect to these criteria, it is possible to say what is right and what is wrong. No such criteria exist in human affairs although people often try to legislate such criteria into existence. Left-wing politicians will try to establish a ruling that the National Front is 'wrong'. And the National Front will try to do the same in respect of Communist organisations. The fact remains that a person who is (say) anti-Semitic may well be (from certain points of view) incorrect. But the error(s) that he is making about Jews cannot be equated with the sort of error that a schoolboy makes when he insists that $0.3 \times 0.3 = 0.9$ (instead of 0.09).

The difference between the two cases does need to be elucidated, however, in terms of the way in which yardsticks of correctness get constructed.

Ultimately, there may be only two kinds of error. In our dealings with any situation whatever, we can either (a) omit a relevant distinction, or (b) import an irrelevant distinction. However, this rather abstract formulation is not of much help to the practising teacher. What the teacher wants is something more detailed - e.g. a set of procedures which will help him to detect errors as quickly as possible (when they are present, or incipient), and a follow-up set of procedures which will help him to eradicate the errors in question. The content of this thesis tends to be couched in these more specific terms, because it is explicitly concerned to demonstrate the practical utility of subjecting errorful behaviour to systematic scrutiny.

There is no shortage of interesting questions to be asked at this more concrete level. Here are a few such questions:

Is it possible to teach in ways that are likely to minimise the occurrence of pupil error? If Yes, is it necessarily desirable to teach in such a way? (In other words, might there be some advantage, under certain circumstances, in exposing pupils to opportunities to make errors? If Yes, what are the circumstances in question?)

Are there any kinds of error which cannot, even in principle, be avoided with certainty? If Yes, what are the errors in question?

Given that errors occur, what procedures would maximise the chances of their early detection? Are error-detection procedures likely to give rise to undesirable side effects - e.g. by holding up the bright student who is not in need of such procedures?

Is it possible to make a meaningful distinction between the errors that a pupil brings to a teaching situation, and the errors that are created inside him as a result of sub-optimal teaching?

Given that an error is detected, are some error removal procedures more desirable, pedagogically, than others? What alternative error removal procedures are there, and what are their respective merits? Is it the case that different kinds of error removal procedures are optimal for different circumstances?

If a pupil is found to be suffering from more than one misunderstanding, what order should be observed in dealing with the various misunderstandings detected? How do we decide which misunderstanding to tackle first?

Is it possible to secure a characterisation of the various kinds of relatedness among errors? Are some errors more deeply rooted (and, for that reason, harder to eliminate) than others? To what extent can analysis of errors and their relatedness be exploited to enrich the teaching experience to which the pupil is subjected?

These, and many other issues, are raised in the thesis that follows. It should be clear that any one of these questions might well have constituted the sole content of a Doctoral Thesis. At the risk of giving the thesis a somewhat discursive appearance, I have chosen to say something about all the questions listed. This is because it seems to me to be of paramount importance, at this stage, to establish the case for investigating errors, per se.

The primary aim of this Thesis, therefore, is to delineate what seems to me to be a surprisingly neglected area of enquiry. The scientific investigation of pupil and teacher error is, in my opinion, both possible and desirable. It is abundantly clear that pupils make errors and that teachers, in their turn, make errors in the handling of pupil errors. These matters are open to fruitful enquiry, as the present Thesis tries to show. There are implications, also, for the more general issue of human error. In textbooks on Research Methodology, and in works (e.g. by Karl Popper) on the Philosophy of Science, there are numerous hints on ways of avoiding error in the field of scientific enquiry. Indeed, Popper has grounded the whole of his philosophy on the principle of falsifiability. According to Popper, 'real' science (as opposed to 'pseuedo' science) is characterised by a tenacious search for errors in thinking. There are certain difficulties in Popper's position - arising from the fact that if (as Popper claims) we

can never prove that we are right, then we can never prove that we are right in believing that we are wrong! In other words, the ascription of error might be mistaken. However, it is important even to have glimpsed the possibility that one is mistaken. And there is an obvious need, in all areas of human endeavour, to perceive possible flaws in one's own thinking. The Thesis accordingly touches upon matters such as this, in order to set the educational thesis in a broader context.

At the end of the thesis work, the author remains a little puzzled by the neglect of this ubiquitous problem of error. It is almost as if philosophers and scientists have, down the ages, been obsessed by Truth, rather than Error. If there is only one Truth (as some people hold), but infinitely many Falsehoods, it is clear that Truth and Error are not symmetrical opposites. In our study of what is the case, we cannot therefore claim to be studying 'by implication' what is not the case. The failure of scientists to resolve some impasse (e.g. in fundamental physics) partly testifies to this in the sense that, when they have marshalled all the facts at their disposal, they are not necessarily able to see what it is that they are doing wrong. The nature and origins and forms of Error surely need to be studied in their own right. The present thesis makes a small contribution to such a study, within the limited but important domain of conventional teaching.

CHAPTER 1

INTRODUCTION

This thesis, and the corresponding research, is based on the view that educators might considerably enhance the effectiveness of their teaching by investigating, in a more self-conscious way, the learning obstacles which their students encounter. In practice most teachers claim to pay special attention to their students' difficulties. However, there is compelling evidence to suggest that teachers could do considerably more for their students in this respect than many do at present.

Several significant "missed opportunities" for enhancing learning, using 'error factor' techniques, will be investigated and demonstrated at length in this thesis. Further criteria will be reported to reinforce these conclusions concerning the significant potential for improving overall teaching effectiveness, which the exploitation of these techniques can provide. Furthermore, it is intended to present evidence to show that error, per se, can be usefully theorised about in the context of learning or action in general.

The expression 'error factor' (EF) was coined by Harlow (1949) to denote a dimension of confusion which gives rise to a cluster of errors. The invention of this expression took place in the context of his research into 'discrimination learning' with rhesus monkeys. Apparently Harlow did not realise (or was not interested in) the significance of EFs as tools that teachers might use to aid learning. It is a major aim of this thesis to pursue some of Harlow's ideas with a view to examining more closely the nature of student error. Some obvious questions to be asked in this context are:

- (a) What is it that teachers actually do concerning the errors of learners?
- (b) What is it that they could do to enhance learning and resolve learning difficulties? (i.e. if they were provided with special strategies in this respect for identifying and treating EFs.)

BACKGROUND

This investigation addresses a vast and largely unexplored area of learning, and consequently, there are two themes - one philosophical and the other psychological - which extend throughout this thesis. These themes are both necessary since, in the context of this research, it is not sufficient to examine, or discuss, psychological factors without also looking at such matters as the nature of truth. This is because the notion of error is at least in part a 'relative' one (i.e. errors are meaningless unless related to some 'truth'). This thesis will therefore, be partly philosophical in content, in addition to containing more practical psychological theories and evidence.

A further reason why this research has been undertaken, is because it appears that a more cogent analysis of EFs could produce valuable practical results. This could lead to the provision of special error treatment schemes for teachers (at relatively cheap cost) for use in real classroom situations. Eventually, it is hoped that the whole area of errors, in the context of learning, will be opened up for more systematic examination. For these reasons the investigation will not only be directed towards learning and teaching, but extended to reveal appropriate general epistemological factors, which will be discussed as they are identified.

EFs AND 'LEARNING DIFFICULTIES'

Existing relevant literature on this subject is fairly scant; however, there are various papers which have some bearing on the subject of 'learning difficulties'. Unfortunately, the concept of EFs, and the associated phenomenon of 'errorful behaviour', has not been subjected to very intensive scrutiny in these papers. In fact, it is rather the case that, when students do not perform as well as their teachers expect, or would like, explanations are given in terms of their low I.Q., poor concentration, and so on. For a number of reasons, which will be made clear later, this is not the approach which will be adopted in this thesis. Neither is this thesis concerned with those learning difficulties associated with 'retarded' learners, student indiscipline and the like. It is concerned with the generation of new perspectives in teaching concerning learner's difficulties, and the improvement of learning by the employment of schemes or strategies based on EF theories.

DEFINITIONS AND COMMENTS ON EFs

In his paper on the formation of 'Learning sets' Harlow (1949) refers to what he calls 'error producing factors'. Later, Harlow (1950) introduced the term 'error factor' and describes certain classes of errors which are

produced by these. He considers that all mistakes, made during learning by a learner, are EFs. However, he defines EFs as 'orderly but inappropriate responses to problem solving' and suggests that they are 'blocks' to learning. Harlow equivocates regarding errors and EFs in the learning context. For his research he was investigating 'discrimination' problem solving in monkeys and observed that, initially, they employed a slow process of 'trial and error' learning. However, with experience of a large number of similar, but different, problems they greatly increased both their speed and efficiency. They had thus learned a method of solving certain types of problem, not just one problem. In his theory of EFs Harlow proposes what could be described as a 'causal agencies' model of errors, and his theory is really a 'contingency' theory.

Levine and Schrier (1959) have suggested a reformulation of Harlow's definition of EFs. They prefer to define EFs as unique patterns of responses made to irrelevant aspects of the stimulus situation. (i.e. responses to those stimuli which are not connected with the reward to the same degree as the correct object or cue.) The irrelevant stimulus acts, in their opinion, as an 'error factor producer' (EFP) when the responses of the subject are correlated with the stimulus for a given number of trials. They distinguish four classes of stimuli which may serve as EFPs. At a later stage it will be valuable to examine these four, since they are particularly relevant to the question of error development (which will subsequently be discussed in detail). It is worth bearing in mind, however, that, whilst the experimenter knows what is 'relevant' and what is not, the subject has to discover this for himself.

Levine (1959) prefers to use 'H' rather than the term 'error factor' because he feels it has a more systematic connotation. The term 'hypothesis' (H) was first employed in the learning context by Krechevsky (1932). He used it to describe systematic response patterns in rats. However, Levine (op.cit.) defines 'H' as a mediating process and considers that it is a dependent variable (since it is influenced by, or dependent on, rewards). Thus, the EFPs referred to in the previous paragraph are the independent variables.

It is noteworthy that Lewis and Pask (1965) point out that, strictly speaking, any error made by a learner can be ascribed to an EF. Nevertheless, they consider that the most interesting EFs are those which generate whole classes of errors. Lewis (1966) defines EFs as the 'promoters of underlying confusion'. However, it may also be helpful to regard EFs as the sources of misunderstanding which, in turn, result in the production of errors.

Similarly, it may be more suitable to think of EFs not merely as 'blocks' to any further learning in given situations, but as 'systematic' yet wrong ways of responding in problem situations. Hence, they are not just obstacles to learning but can also be considered as 'the promoters of critical confusion'. It is interesting that some teachers actually claim tacit acknowledgement of EFs in their approach to teaching. However, this claim has been found to be somewhat dubious.

It is now necessary to attempt to provide a first definition of 'error' itself so that it is clearer what this thesis intends to examine. Ultimately, it may be considered that there are only two kinds of error (i.e. the omitting of a relevant distinction, or the importing of an irrelevant distinction). From an experiential point of view error first manifests itself in the form of 'self-frustrating behaviour'. (An organism tries to do something, is less successful than expected, and, in consequence, begins to sense that something is wrong - more will be said about this later in this chapter.)

EFs IN THE CLASSROOM

The author suggests that it is often not only insufficient and inappropriate for the teacher just to arrange that learners' errors are rectified by giving them the correct response, but, to make matters worse, valuable opportunities to enhance learning may be missed. Furthermore, the rectification of EFs can result in the clearing up of a whole area of misunderstanding in the same process. It is this unique property which is of special significance in relation to the objectives of this investigation, concerning the role of EFs in teaching.

There appear to be various forms and types of EFs in the classroom and these will be examined later. However, it is important to point out that a learner can make relatively greater progress when he masters, or overcomes, the causes of certain types of EFs. If techniques and schemes for identifying these types can be devised, then teaching could be made far more efficient. This provision should also mean that a knowledge of various types of EFs would thus enable the teacher to 'quantify' task difficulties for his students. Moreover, if it were not for the existence of underlying EFs, teaching could be inordinately long, because errors would need to be dealt with in isolation - one at a time.

Rules could be provided concerning the treatment of EFs to replace the unreliable and insufficient intuitive methods - which some teachers claim to have adopted. A number of the theories concerning the role of EFs in the classroom, which will be postulated later, are intended to have practical implications for teachers. Moreover, teachers could still give their own

individual interpretation to the application of the techniques which will be proposed. However, not all the ideas and measures which will be advocated are intended exclusively for the teacher. In fact, certain joint learner teacher strategies will be proposed, as will techniques where learner - learner participation is also required to fully exploit EFs for improving learning success. Hence, the extinguishing of errors is not the main concern of this thesis, but rather the provision of means for exploiting EFs to help make teaching more effective.

LITERATURE CONCERNING EFs

Having provided some initial descriptions and definitions of EFs in the context of learning, and given a preview of the reasons why this investigation is considered to be worthwhile, it is now appropriate to survey relevant literature on the subject. As there is no corpus of literature on the subject of this thesis, the literature search will range widely over disparate fields. In the context of this enquiry some of the literature is, perhaps, rather controversial - but it will still be examined so that a more comprehensive picture is attained. Further references to relevant literature will be made at appropriate stages, in order that each facet can be examined under the most effective conditions. Moreover, the literature will generally be discussed in such a way that conclusions may be drawn about it in objective as well as subjective terms.

The initial report on EFs by Harlow in 1949 is, in the author's opinion, a 'watershed' in learning theory. In this paper Harlow identified what he then called 'error producing factors' and he suggested that learning follows the progressive elimination of these factors. Harlow also pointed out in this paper that this same condition was applicable to human learners (in addition to monkeys).

(See figure 1, overleaf)

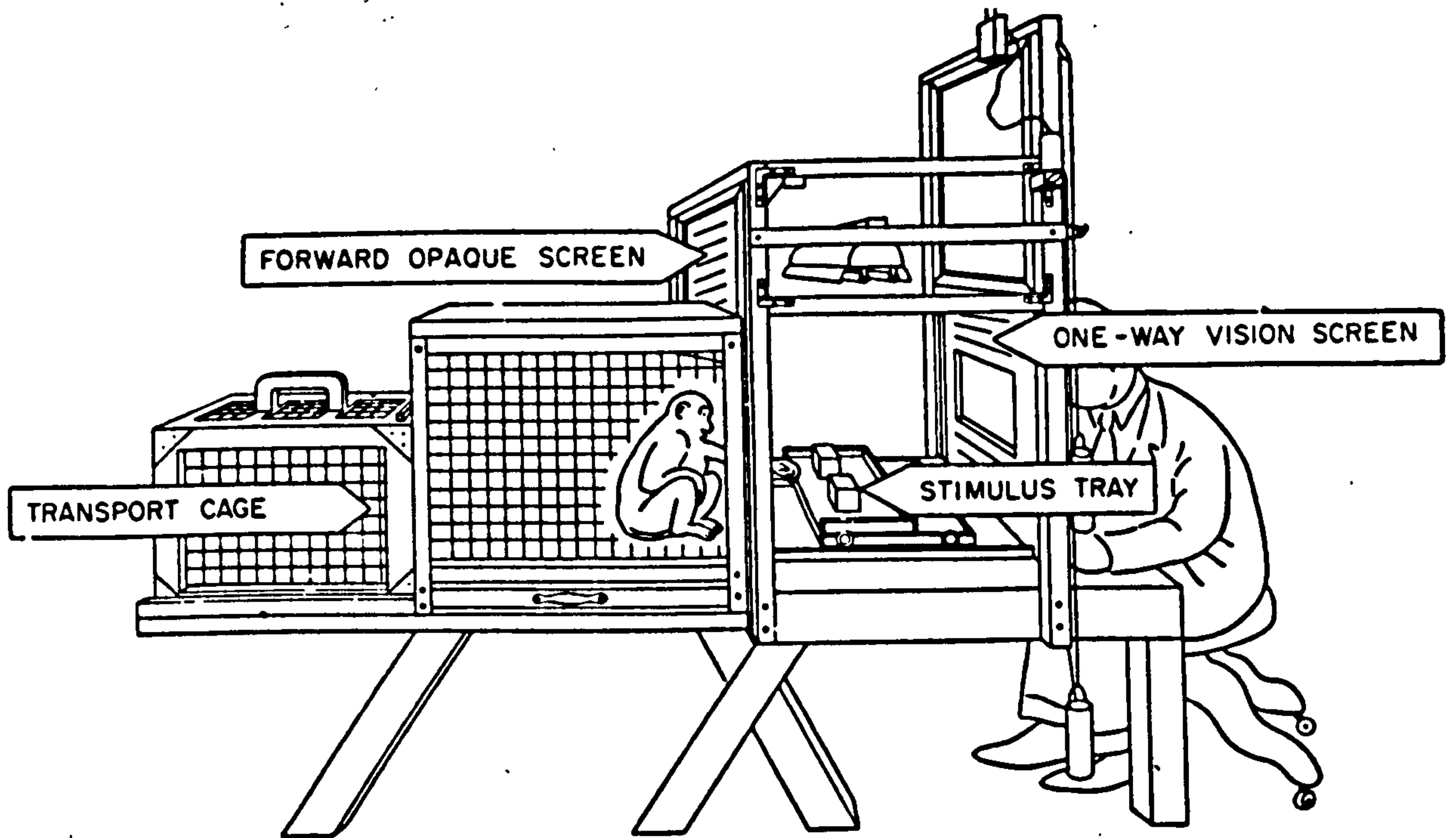

Figure 1

The apparatus used by Harlow in his key experiments.

Briefly, Harlow's key experiment concerning EFs is as follows. A rhesus monkey crouched in a small wire cage in which there was a small hatch through which its arm could protrude. The experimenter faced the monkey from the obscure side of a one-way vision screen. He slid a Klüver-type stimulus tray, which was mounted on rails towards the hatch, as shown in figure 1. In this tray were three objects, two of which were identical and the third one was different (as, for example, shown in figure 2). The learner had to choose the 'odd' one in the set.

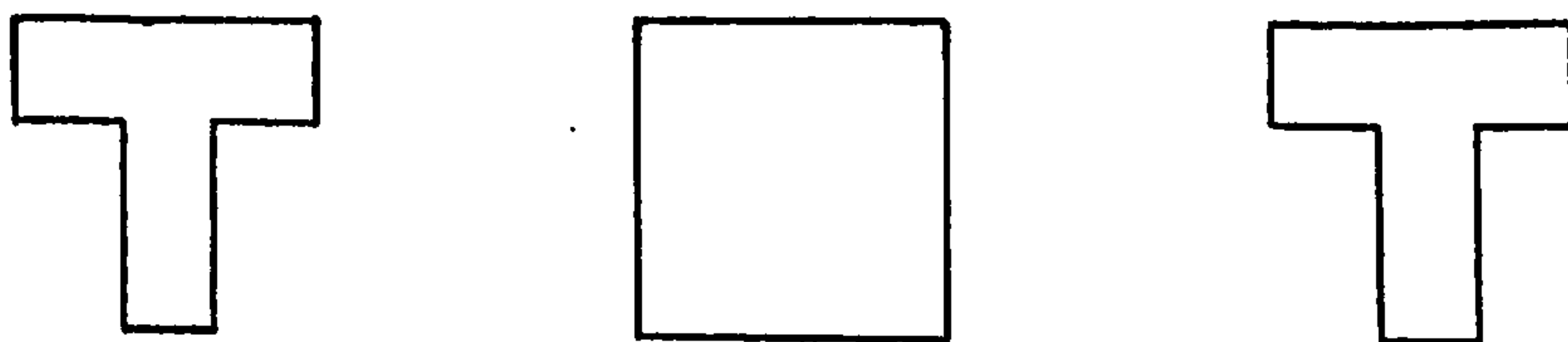

Figure 2

If the monkey picked up the 'odd' object he was rewarded, otherwise he was not rewarded. After each such exercise the tray was removed and a fresh set of objects was presented (such as two discs and a triangle) in different spatial arrangement. The procedure sometimes required a large number of trials, but eventually even the most backward monkey learned the required exercise. Then, apart from a few 'exploratory' variations, the monkey would go straight for the 'odd' object on every occasion. The monkey was accordingly credited with having attained the concept of 'difference' or 'oddity'. In the context of experiments such as this, Harlow identified several important EFs, some of which were more specific to the type of

problem being learned, while others were rather general in nature. Using a judicious arrangement of test problems he was able to show:

- (i) how the presence of EFs could be determined in individual cases,
- (ii) the frequency of such EFs in the population of monkeys studies, and
- (iii) the most likely order of their occurrence in the training routine.

He showed that errors made during 'learning set' training are not just accidental misses. In many instances they were found to be systematic response tendencies that were inappropriate to the solution of the particular problems. In other words, they were plausible but incorrect guesses. Harlow concluded that learning occurs due to progressive elimination of erroneous guesses. However, it needs to be pointed out (again) that these are 'errors' only from the point of view of the experimenter, who already knows (and decrees) what is 'really' correct. From the viewpoint of the monkey, the responses are actually intelligent probing guesses. In the absence of a humanlike communication system between experimenter and monkey, the monkey cannot do better than guess.

Originally Harlow identified four EFs which were related to a selection of negative stimulus objects. These will now be briefly outlined since they indicate different aspects of error which can exist in the learning situation. Although this relates to the learning of the concept of 'oddity' between sets of objects by rhesus monkeys, it was later found that similar results are obtained with human subjects (e.g. when this type of experiment was repeated by Kuenne with young children as the subjects).

Harlow's 4 Primary EFs

1. Stimulus preservation error

i.e. errors due to the repetitive choice of the incorrect stimulus object. (It is significant that the number and persistence of these errors decreased during the course of 'learning set' training.)

2. Differential cue error

i.e. distinguishing the inappropriate cue when several cues are rewarded. (These errors decreased with experience but reappeared during 'reversal' learning.)

3. Response shift error

i.e. the tendency to respond to both stimuli in an object discrimination task, so that one stimulus is not consistently chosen. (Later investigation revealed that this error was related to the quantity of reward i.e. fewer errors when large reward.)

N.B. No effect was found between type 1 or type 2 errors and quantity of reward.

4. Position habit errors

i.e. errors resulting from the learner always preferring one position in object discrimination problems. (This was found to have a gradually negligible effect upon discrimination learning efficiency.)

All of these observations provide evidence that several EFs function independently. It is Harlow's opinion that 'systematic error removal' results from the gradual elimination of inappropriate response tendencies (i.e. 'learning sets' develop from the suppression of EFs). Hence, he considers that the one basic process of learning is inhibition: this is the 'uniprocess theory' of Harlow and Hicks (1957). While the author cannot entirely agree with this theory (for reasons which will be explained later) it does promote some interesting speculation concerning the fact that the correct response is already part of the learner's behavioural repertoire - but is blocked by the inappropriate responses. Furthermore, Harlow observed, in addition to the foregoing four classes of EFs, that anxiety, lack of concentration and poor motivation were also EFs. It is noteworthy that Harlow (1959) summarises work on EF analysis by saying:

"..... it may be stated that in spite of the limited research conducted thus far on 'error factor' analysis a number of interesting phenomena are evolving. It is a reasonable hypothesis that the suppression of all error factors defines perfect learning, and that learning is nothing but suppression or inhibition of error factors. Several error factors have shown to be subject to suppression or augmentation outside the test situation. Finally, in at least one case, we find completely different action between an incentive condition and the error factors operating within a problem. This data suggests that error factors are functional units whose suppression underlies learning".

It will now be helpful to examine the EFP stimuli, identified by Levine and Schrier (op.cit.), which were mentioned earlier. The first of the four classes of stimuli, which may serve as EFPs, that they distinguished, is the class made up from those cues which are spatially differentiated (even though they are constant from one trial to another). A second class which they identified is that consisting of changing cues in what is traditionally described as the 'external' environment. (Perhaps a teacher's idiosyncratic

behaviour could be such a source of error producing stimuli) Their third class contains those stimuli which result from the behaviour of the learner. They considered that this class was the major source of 'random' response sequences. Finally, the fourth class of stimuli which could produce EFs, that they distinguished, are those made up from the rewards and non-rewards 'experienced' by the learner in preceding trials. (The teacher could do well to take account of this possibility when rewarding a learner's work.)

A further observation which Levine and Schrier (op.cit.) made is quite significant in the context of this investigation. This observation is, that the greater the number of EFPs then the more difficult the learning task or problem. They argue, however, that the converse is not true and that difficult tasks may not necessarily contain a large number of EFPs. (This is a point which will subsequently be referred to in relation to the teaching of complex subjects, difficult subject matter, and to 'high level' learning.) Their findings suggest that, in order to 'stretch' a given student, the teacher could increase the difficulty of a problem (as appropriate to that student) by increasing the number of EFPs associated with it.

However, the observations of Piaget (1923), concerning the errors made by young children during learning, provide some further illumination with respect to our understanding of the nature of errors. He discovered that, as the child developed learning skills, so the errors which he made changed both in level and form. Furthermore, in his studies of judgement and reasoning in the child, Piaget (1928) traced the origins of certain difficulties in reasoning and discovered that these often arose from a single underlying source of confusion. For instance, he found that several misunderstandings often arose from the child having an incorrect conception of 'volume'.

It will also be useful to briefly survey the views of Thorndike (1895) regarding learning and errors, in order to provide a clearer background to this enquiry, before proceeding to more specific aspects of EFs. His 'law of effect' relates to his conclusion that the greater the satisfaction (reward) then the greater reinforcement it produces, and vice versa. Moreover, Thorndike considered that learning results from 'stamping in' (reinforcing) correct responses and 'stamping out' (not reinforcing or extinguishing) incorrect ones. (Errors therefore become eliminated through their adverse consequences.) In some ways this is rather a crude law, since it does not account for insight, comprehension and so on. Nevertheless, it does indicate the way in which learning and errors were originally believed to be inter-related.

LITERATURE CONCERNING THE PROPERTIES AND USES OF EFs.

It is interesting that Moon and Harlow (1955) have observed some regression by learners to more primitive 'error patterns' (which they found was the result of a change or reversal in object discrimination problems). This effect could be of value to the teacher for identifying basic EFs. Furthermore, the progressive reappearance of previously suppressed EFs, following a measure of protracted failure in a problem solving situation, could be a mechanism of high adaptive value in teaching. Hence, if learning is considered in terms of the elimination of the EFs operating within a particular topic or problem, it should, therefore, be possible to 'prepare' a learner before he commences a further stage. Moreover, reference to a learner's past history, and to the nature of a particular learning problem, could enable the teacher to predict EFs for this purpose.

It is also noteworthy in this context that Lewis and Pask (op.cit.) have employed the concept of EFs as a central feature of their cybernetic models of learning and teaching. In addition, they have advocated measures for enhancing learning by the employment of techniques for either extinguishing, or promoting mastery of certain EFs. Furthermore, they have a particular interest in 'adaptive' teaching systems and machines - which are based on certain of these measures.

With regard to learning and problem solving, Reitman (1965) stresses the importance of learners being given advice or help with the structuring of problems, and with obtaining clear definitions of particular problems. (Perhaps this 'structuring' could be better facilitated by the implementation of EF analysis techniques in the learning situation.) On the other hand, Gagne (1967) thinks that the capability of the monkeys which Harlow (op.cit.) observed for insight (concerning problem solving of the 'oddity' discrimination type) did not arise through their 'structuring' of the situation - in the sense of formulating and later testing tentative hypotheses about the situation. He considers that it resulted from their accumulated experiences - based on many individual trials of previous learning. Gagne also suggests that we do not learn to read by insight (or speak a foreign language). He suggests that we do learn by solving problems but we also learn things which are not problems at all (e.g. learning such things as propositions, facts and principles). Nevertheless, Gagne feels that Harlow did show that monkeys could learn concepts, such as 'oddity', and could apply this concept.

In addition, Harlow's experiments have a possible further value because they demonstrate that some element of 'ordering' was involved in the monkey's problem solving. Gearheart (1973) also notes that there is a need, in reading and spelling, for the learner to order items in a correct series. Since, in

order to spell, a learner must correctly place letters in a series, then perhaps a learner's success in this context could be affected by certain EFs. (In which case this could be a possible basis for the teacher to resolve the learner's spelling difficulties.)

It should be pointed out that some investigators, such as Lunzer and Morris (1968) have suggested that EF theory can be usefully given a mathematical representation. A similar view has led some researchers to suggest quasi-mathematical models in this respect. For example, Restle (1958) formulated a mathematical model of 'discrimination learning set' formation. Using parameters based upon this model, Miles (1965) reports that the general formula produced theoretical learning functions which corresponded quite closely to intra-problem learning curves which had been obtained by Harlow (1949). This model is considered by Miles to be a generally satisfactory one, within certain limitations. An alternative approach, concerning 'learning set' formation, is that of 'hypothesis behaviour' advocated by Levine (op.cit.), which was described earlier. More recently, however, Levine (1975) has admitted that, until the nature of EFs has been properly evaluated, 'hypothesis theory' must remain incomplete.

It is unfortunate that the interaction of EFs (with one another) has not really been investigated to any extent, and so there is very little literature on this subject. Nevertheless, Harlow and Hicks (1957) consider that EFs can actually interact - as do Lewis and Pask (op.cit.). Furthermore, in their work on a 'Uniprocess' learning theory, Harlow and Hicks question the concept that learning is the result of two processes - 'excitation' which follows reward, and 'inhibition' which is generated when no reward is received. They feel that it is more consistent with EF theory to assume that a single process underlies learning. This one basic process of learning is, they believe, 'inhibition'. Moreover, they consider that one way in which EFs are suppressed or eliminated is by their interaction. While the author agrees in principle with this latter conclusion, it is felt that it fails to account for the possibility of interaction leading to EF reinforcement, as well as to EF removal. Similarly, the 'transfer' of EFs is another important aspect in this context which has been greatly neglected. However, Stones (1966) suggests that, if transfer of learning is desired, then EFs can play a valuable role - since the learning from mistakes which these involve can be extended to other topics or subjects. This view is also held by Mouly (1971) who points out the relation between learning transfer and learning experience - which can frequently be associated with EFs.

PROGRAMMED LEARNING AND 'ERROR FACTORS'

The literature in this context is again very sparse with respect to EFs. However, Lewis (1965) suggests that, although the concept of EFs might seem to be an unnecessary addition to the technical vocabulary of the programme writer, it is nevertheless true that all programme writers acknowledge intuitively. For instance, when they offer 'cues' or 'prompts' they tacitly acknowledge the possibility of error. Lewis also observes that, in writing 'branching programmes', there is a positive search for possible misunderstandings. (In fact, errors constitute the main basis for 'branching'.) Moreover, he points out that following the selection of an incorrect response steps are then taken in the programme to remove the misunderstandings that were possibly responsible for this.

Furthermore, Skinner (1953) considers that successful learning, using 'linear programming' methods, ideally demands the removal of all sources of error. His idea is that all responses should be correct to be beneficial, and all incorrect responses should not be reinforced. The general ethos of Skinnerian behaviourism is really one of 'anti-punishment'. In more recent work Skinner (1975) has put even greater stress on the need for learning by reward only. The view of Skinner (op.cit.) concerning 'rewards' and learning has, in the opinion of Meier (1976) led to an undesirable condition which may result in 'token learning' by the student. This situation has been investigated by Levine and Fasnacht (1974). They discovered situations where the learner would not apply himself to learning without being given some reward - which is typically external to the learning task.

Lewis (op.cit.) feels that the possible presence of EFs is tacitly acknowledged in cases where the programme writer pre-adapts or cues the programme to suit the population of learners for whom the programme is being written. For instance, Russell (1970) has written programmes to teach basic arithmetic skills in which she took account of learner's difficulties by introducing special 'frames' to remedy these. She based her techniques and 'frames' mainly on the experience of teaching arithmetic to a wide range of learners and on information obtained from diagnostic tests. Hence, the efficacy of the remedial frames which she provided was really a question of judgement - but with certain basic evidence to reinforce it. For example, in 'long division' problems she found that some learners were employing a 'mirror image' strategy, rather than making actual errors in the numerical processes. The following example illustrates such a case:

The student was asked to divide 692 by 4 and gave the answer 288, instead of 173. However, on examining his working it is clear that he has added rather than subtracted from the number being divided. These incorrect values are shown circled.

$$\begin{array}{r}
 \textcircled{8} \quad \textcircled{32} \quad \textcircled{32} \\
 4 \quad) \quad 6 \quad 29 \quad 32 \\
 \hline
 \text{Answer} = \quad \quad \quad 2 \quad 8 \quad 8
 \end{array}$$

He has said, 4 into 6 gives 2 over and 6 + 2 = 8, then 4 into 8 = 2 and so on, giving remainders which equal 32, and 32, respectively - both of which he has correctly said are divisible by 4 eight times.

After discussing her work Russell (private communication) has indicated that it now seems to her that the repetition of an error was crucial in revealing the presence of EFs (although she was actually not previously aware of EFs as such). She now also stresses the need for the learner being taught how to recognise when he has done something 'correctly' - which is something that the author also considers is lacking in many learning situations.

It has been suggested by Lunzer and Morris (1968) that EF theory should be employed in 'programmed learning' design - rather than measures mainly being taken to avoid errors. However, Lewis (op.cit.) feels that there is a growing awareness amongst programme designers of the notion of EFs. He points out that, for instance, when they wish to exemplify a concept to be learned, they choose examples which will probably correct or avoid incipient misunderstandings. Finally it should be pointed out that Smith and Moore (1965) have studied the formation of 'learning sets' in programmed instruction and have observed that error rates decreased as a function of the number of previous programmes which the learner had experienced. More will be said later concerning these consequences in relation to EF theory.

SUMMARY OF ASSOCIATED LITERATURE RELEVANT TO EFs

Since it is intended to provide a survey of relevant literature which is adequately comprehensive, reference will be made to certain areas and topics of literature which are associated with the main themes of this research. The first such reference concerns recent research by Halfp (1975) into 'stimulus presentation' after successes and errors in concept identification. He found that his subjects' (42 female students) memory for the stimulus was an important determinant of the efficiency of the revision after an error. His results support Levine's (op.cit.) view that, re-presentation of the positive member of the display pair during error feedback enhances performance, whereas its re-presentation during success feedback does not. Thus, it appears that contrary to the opinion of Terrace (1963), the presence of some errors can make learning and the revision of learning more

effective. (This is a possibility which will be explored in detail.)

Rabbit and Rodgers (1977) have also investigated the behaviour of a subject after making an error.¹ They found that the subject's responses were often slow immediately after the error and were also inaccurate. However, they found that responses were not slow when the subjects were required to make an 'error correction' response. This is quite an important discovery, particularly if viewed in the practical learning context. Another of the findings of Rabbit and Rodgers, which is of significance with respect to this investigation, is that they found 'pairs' or 'triads' of errors occurred more frequently than they should if it was only a question of chance. Thus, in the context of learning, this could prove to be a significant factor regarding the removal of several errors or misunderstandings simultaneously. It is also noteworthy that they observed that, following error commission, the subjects frequently made irrelevant responses.

It should be pointed out that some studies of certain 'learning difficulties' have revealed the part which errors can play in promoting or exacerbating such difficulties. For example, Wood (1959) has examined the difficulties experienced by learners who exhibited considerable confusion only in certain subjects. He concluded that, quite often, these difficulties would not have become significant if the learner's errors and confusion were eradicated when he first experienced or displayed them. Similarly, Wing (1975) suggests that the language difficulties associated with autism are often considerably exacerbated because of the teacher's failure to correct early confusion. One way in which this may be achieved, according to Pickthorne (1976), is to allow the learner to work through certain of his errors (as soon as they are observed) and use them as part of the language therapy. However, problems are sometimes found to be attributable to a common cause. For instance, Freud (1917) has claimed that abnormal behaviour often seems to stem from a single cause. Moreover, rectification of this underlying cause frequently results in a major change in behaviour.

In another context De Groot (1965) has made a detailed study of the thoughts and strategies of 'chess masters'. He feels that their errors in this context cannot, in general, be ascribed to reproduction tendencies which are not connected to their tasks. Nevertheless, he thinks that such errors could be the result of partial conception or comprehension. He also concludes that they can arise as a result of the task being misconceived. Furthermore, De Groot suggests that many errors made by 'chess masters' are not disconnected or senseless errors. It is noteworthy that the World Chess Champion, Capablanca, once claimed that he learned more from one chess game lost than hundreds which he won.

1 This was an analysis of response programming using simple mechanical tasks.

There have been errors attributable to 'system separation'¹ during problem solving reported by Van Hiele (1974) which are of particular significance here. Moreover, he observed that these frequently stem from the transfer of basic errors or confusion from one system, or subject, to another. Similarly, the effects of errors in 'reasoning' were also found to be transferred - thus increasing the corresponding sphere of difficulties. One way of resolving this could be for the learner to use algorithms. These have been successfully employed by Lewis (et.al.) for problem solving and error avoidance purposes. Similarly, Landa (1974) suggests that students could be taught how to devise algorithms so that they can deal with their own errors.

Alternatively, special rules could be provided to help the 'slow learner' to avoid certain pitfalls, and they could also be used to reduce the total number of errors which the 'average' learner makes in a given context. For instance, Cotterell (1971) has investigated ways of helping the bad speller and suggests that they can have their learning load reduced with the aid of spelling rules. Perhaps these rules could also be of aid to the 'average' speller because it should mean that the amount of error correction necessary would be reduced. This is important since too much error correction is considered by Olsson (1972) to be as undesirable for effective learning as is too little correction.

LITERATURE CONCERNING ERRORS AND LANGUAGE LEARNING

The conclusions of Lee (1976) reinforce those of Olsson (op.cit.), with regard to encouraging and discouraging errors in language learning. Moreover, while not actually advocating the teaching of language errors, Lee feels that the presence of certain errors can aid learning, and the study of such errors can be useful for discovering what a language learner's difficulties actually are. Furthermore, Spector (1972), in studies of the language learning of 'bi-lingual' learners, observed definite 'patterns of difficulty' and errors. Apart from 'general' difficulties she feels that there is a need for evaluation of individual learner's errors and associated confusion. Olsson (op.cit.) has also observed that learners studying a second language made errors which followed highly systematic patterns. She concludes that there is evidence of a distinct 'analogous pattern' of contributions to learning procedure made by language learners in terms of their errors.

Studies by Kaldor and Shell (1970) of 'multi-lingual' and 'monolingual' students, who were learning English language, have also revealed common patterns of errors and difficulties. However, they identified a number of 1 (e.g. in mathematical physics where two 'systems' are jointly involved).

errors which were not common to both 'multilingual' and 'monolingual' students, but were common within each group. Hammarberg (1974) considers that there is a need for non-errors to be taken into account, along with actual errors, by language teachers. He feels that this approach could provide the teacher with a better assessment of learners' misunderstandings. In this way he considers that the teacher could also obtain a more specific assessment of a learner's current command of the language. Furthermore, useful clues in this respect would be provided by the identification of significant 'non-errors' at given stages.

However, Tran-Thi-Chau (1975) believes that what basically constitutes 'difficulty', in the learning of a second language, is still a baffling problem which demands that strategies are devised to identify the causes of errors. In a series of special tests Tran-Thi-Chau observed that 'interlingual' interference was the largest single cause of errors in second language learning. (Perhaps similar forms of 'interference' in other subjects and learning contexts could be responsible for promoting some learners' errors.) Unfortunately, this is an aspect of learning difficulties which few teachers appear to take into account.

Corder (1962) suggests that an examination of a language learner's errors can be significant in several ways. For example, he points out that these can tell the teacher how far the learner has progressed, and what remains for him to learn. He feels that the presence of certain errors is also useful for the language learner, since he can regard such errors as tools or devices to be used in order to learn. Moreover, Kellerman (1974) advocates that language learners could be given certain 'reconstructed' errors (to receive their approval or rejection) in order to enhance their learning. Furthermore, based upon this information, he considers that an abstract 'characterisation' of errors can be made by the teacher. He also proposes that 'elicitation' techniques should be employed, concerning the diagnosis and treatment of learner's errors.

Stevens (1971) also believes that the employment of error analysis in language learning has particular value, because it can provide significant and precise information concerning learners' progress. In his opinion, the identification of errors in the context of language learning is essentially subjective. Nickel (1971) feels that there is a need for language learning difficulties to be interpreted from the learner's point of view, rather than the teacher's (which is also often the case in science teaching). In addition he considers that some target is needed, so that errors may be judged more effectively in particular learning contexts. A further

interesting observation by Nickel is that, especially in early learning of a foreign language, most girls have fewer difficulties than boys. He thinks that girls are less inhibited at this stage - which could partly account for his observation that they are less afraid of making errors.

An important point, which is emphasized by Brann (1972), is that language teachers should arrange 'aural dictation' tests so as to take account of error producing factors (such as their own idiosyncrasies). He identifies a number of 'common errors' which the teacher could perhaps anticipate, with experience, and he also stresses the need for good 'ordering' of subject matter to overcome errors and learning difficulties. In another respect Cotterell (op.cit.) considers that in dealing with spelling difficulties, it is the type of error that a learner makes within a word which indicates the basis of his errors, rather than the actual word which is misspelt. She suggests that if the teacher makes a study of learners' errors in spelling this would provide a basis for more 'systematic' teaching. These are further measures which will be taken into account in formulating general strategies for treating EFs in the classroom.

LITERATURE CONCERNING ERRORS AND ARITHMETIC LEARNING

Some interesting experiments and conclusions concerning the diagnosis and treatment of misconceptions (or 'bugs') in arithmetic, have been provided by Brown and Burton (1977). They have constructed diagnostic models using a 'representational technique', which is called a 'procedural network', as a framework for this construction. A significant observation of theirs is that students "frequently use wrong procedures in problem solving rather than use correct procedures erroneously". Another important implication of their research is that teachers should not merely assess the student in terms of the overall number of errors made in a given test, but they should also analyse the student's attainment with regard to evaluating the basis of his errors.

Brown and Burton (op.cit.) also stress the need for teachers to be more appreciative of the difficulties in inferring the basis of a student's misconceptions from his wrong answers, and they propose that systems of strategic 'test' problems are provided for this purpose. Furthermore, they have devised and employed diagnostic models framed in the context of a computer based 'tutoring' system. Their object was to diagnose 'bugs' strategically and hence provide a better understanding of the underlying structure of arithmetic skills. Moreover, Brown and Burton have demonstrated the use of their 'procedural network' as a tool for automatically diagnosing student behaviour in learning arithmetic, and for

generating 'diagnostic tests' in this context. In addition, they have developed measures which can be employed to judge the diagnostic 'quality' of certain arithmetic examinations or tests. However, they point out that care must be exercised in 'generalising' their model, in order to employ it with certain other procedural skills besides arithmetic.

Smith (1969) has identified five common areas of error made by students who were learning basic arithmetic. These are errors associated with:

1. Tables and fundamental facts.
2. Use of zero.
3. 'Carrying', in addition and multiplication.
4. Use of decimal point.
5. 'Borrowing' in all kinds of arithmetical subtraction.

He reports that the misuse of algorithms contributes significantly to learners' errors in 'arithmetical subtraction'. His observations are that there is a high degree of similarity in the type and number of errors made by particular groups of learners. In his investigations Smith was concerned with 'constant errors' (i.e. not random mistakes) and this is in keeping with the approach which will be undertaken in this thesis. It is worth mentioning that Smith reports that the basic errors and confusion which he observed, are essentially the same as those reported by investigators over 40 years ago. This surely shows the need for more positive and effective measures to be provided in this context in future. Reference to such measures, along with 'case studies', will be provided in the following chapter.

'ERRORLESS' LEARNING

In order to provide a more complete and balanced literature review, a brief survey must be made of certain literature concerning 'errorless' learning. However, the concept of 'errorless' learning will also be referred to elsewhere in this thesis. Terrace (1963), a student of Skinner (op.cit.) has carried out several investigations in the field of 'errorless' learning. His work has been mainly concerned with 'errorless' discrimination learning using pigeons as the subjects. The method which he used to train a pigeon to 'discriminate', without errors, was based on one that had previously proved effective in minimising the occurrence of errors (Skinner: 1938).

Terrace has also observed the effects of 'disruption' on 'errorless learning'. One form of disruption which he employed was to abruptly change back to the initial discrimination in a new discrimination context (this, he reports, only affected pigeons which had learned with errors). He discovered that doses of chlorpromazine or imipramine also markedly disrupted the performance of pigeons trained with errors - but did not affect the performances of pigeons trained without errors. However, in his unpublished doctoral thesis Terrace (1961) reports an experiment which demonstrates that, under certain conditions, discriminations learned without errors are more susceptible to disruption than discriminations learned with errors.

It is notable that Terrace (1963) actually demonstrated that pigeons which had learned a red-green discrimination without errors later transferred this learning to a discrimination between horizontal and vertical lines - again without errors. He also observed that, once subjects had made errors they tended to continue to make errors - unless steps were taken to rectify them. Later experiments, using young children as the subjects, have indicated similar behaviour in this respect. These results suggest that learning with errors must be specially structured, and should contain provision for error removal.

Kelleher (1965) thinks that 'progressive training', in simple stages, is the chief basis of 'errorless' learning. Perhaps it should therefore be arranged by the teacher that learning tasks and problem solving become progressively more difficult for this type of learning to succeed. Furthermore, Hilgard and Bower (1975) also believe that 'errorless' learning has some value in that it promotes questioning regarding the best arrangement of training conditions. Yet another important observation in this context has been made by Terrace (1966). He states that:

"The numerous examples of emotional responses following discrimination learning may be erroneously construed as evidence that it would be generally desirable to train all discriminations without errors It should be noted, however, that numerous factors would detract from the wisdom of trying to train all discriminations without errors. Perhaps the most important of these is the lack of frustration tolerance that would result from a steady diet of errorless discrimination learning".

LITERATURE CONCERNING THE PHILOSOPHICAL ASPECTS OF ERROR

As this thesis has a philosophical theme, as well as a more psychological one, reference will now be made to relevant philosophical literature pertaining to error. The early Greek philosophers were among

the first thinkers to consider the nature of truth. Some study of this was also made by the 'Scholastic' philosophers of the Middle Ages. Nevertheless, it was not until the seventeenth century that any particularly relevant proposals were made concerning 'truth' and 'error'. These proposals were presented by Descartes (1644) in his philosophical study concerning 'systematic doubt'. He concluded that the 'error' in himself exists because God has given him freedom. Descartes considered that our doubts are particular, and thus have to be resolved in particular ways. Subsequently, Locke (1690) examined the limits of human understanding - which he thought to be associated in some ways with doubt and error. However, only Royce (1885) has examined errors in a context which is of relevance with respect to this thesis.

Royce argues that the conditions which ultimately determine the logical possibility of error must themselves be absolute truth. He has also considered the question of what an error actually is, and he suggests that there are really a number of different forms or definitions of this. Thus, Royce says, an error can be an actual mistake, a misunderstanding, a judgement which does not agree with its object, or an incorrect observation or measurement. He points out that, without error, there cannot be truth. Hence, only what is known can be erred about. Furthermore, Royce suggests that misunderstandings are sometimes the result of other's errors. Moreover, the teacher could do well to ponder about Royce's suggestion that:

"If Thomas could know John's thoughts about him, then Thomas could possibly see John's error".

The possibility that error and truth are essentially relative has also been considered by Royce. This is another factor which some teachers fail to account for - especially when answering the questions of their students. Similarly, the teacher should make it clear that nonsense does not necessarily imply error (e.g. the word 'rfatop' is nonsense in English, but there is no error). However, Royce thinks that we can only say something is wrong if there is a 'yardstick' to judge it by. In addition, he points out that a further yardstick is necessary to judge this yardstick by, and so on, thus resulting in an 'infinite regression' of yardsticks. Ultimately, therefore, the notion of error is injudicious, without some fundamental yardstick. Thus, a student may actually only be committing an error according to a particular point of view.

Moreover, some student's problems in learning could arise as a consequence of errors of judgement. One reason for this, as Royce observes, is that the teacher (or learner) can judge only within their own experience.

Other aspects of Royce's theory concerning errors do not concern us here, except for one further point. This is, that having established the existence of errors, it is possible that to every truth an infinite mass of error may be opposed. Finally, regarding what errors are, Royce concludes:

"What, then, is an error? An error we reply, is an incomplete thought, that to a higher thought, which includes it and its intended object, is known as having failed in the purpose that it more or less clearly had, and that is fully realised in this higher thought. And without such higher inclusive thought, an assertion has no external object, and is no error".

HERMENEUTICS

A brief review of certain literature concerning hermeneutics should prove to be worthwhile at this stage of the philosophical literature survey. The term 'hermeneutic' was originally applied to 'interpretation' in a theological context. (This application actually relates to scholars seeking to determine possible errors in interpretations of the doctrines from the Bible). Hermeneutics has now been extended to embrace sociological, historical and literary interpretation. There could be great value in the teacher exploring possible errors in both his own, and his students' interpretations of subject matter, and so on. It is also possible that misinterpretations could arise either from the teacher's own or his students' erroneous presuppositions - an erroneous presupposition being, in fact, an EF.

In his discussion of hermeneutics Hirsch (1967) raises the problem of evaluation with regard to saying that one interpretation is more 'valid' than another. Such conflict could be a further promoter of EFs in the learning context, since there are not always appropriate 'externalised' criteria of accuracy available to the teacher. An interesting example of literary misinterpretation is also provided by Hirsch. He gave some students of literary criticism a poem by Wordsworth and asked them to interpret its meaning. They concluded that the main theme was about death, and found parts of the poem to 'support' this conclusion. However, Hirsch suggests that the most valid interpretation of the poem is not that it is about death, but about two lovers parting.

Similarly, it could happen that the teacher misinterprets an author and then his students misinterpret his misinterpretation. Moreover, Hirsch (op.cit.) suggests it is possible that the author really does not know what he means himself, and so the position becomes even more complex. Another philosophical question which Hirsch examined is that concerning the absolute

validity of interpretation. He feels that the goal of 'valid' interpretation relates to the fact that one set of conclusions is more probable than others (in the final analysis). Hence, construed in this way, hermeneutics is a discipline which seeks to arbitrate among conflicting interpretations of some facet of the world.

VALIDITY OF THEORIES

Regarding the validity of 'theories' Popper (1935) feels that a theory or view cannot be demonstrated as being correct but it can be proved to be erroneous. For Popper, a 'scientific explanation' is one which can be falsified. If a theory makes 'newsworthy' predictions, and if after testing it one fails to prove that it is in error, then the theory is better established. For instance, with respect to Einstein's general theory of 'relativity' Popper believes that it is scientific, because it could be disproved or falsified (e.g. by observations of the effects of a lunar eclipse).

However, Popper thinks that Freud's theory of psycho-analysis is not scientific, because he cannot see any way in which it can be repudiated. In other words, he considers that, if Freud's theory suggests that human behaviour is basically sexual, there is no effective way of disproving this. (This is a factor which some teachers fail to account for in presenting theories to their students.) Furthermore, Magee (1974) feels that Popper is saying that falsification, rather than verification, is the keynote - since one cannot prove that theories are right but can prove that they are wrong. However, even wrong theories can be perpetuated by the proliferation of further errors of a partially compensating kind.

FURTHER PHILOSOPHICAL FACTORS

There are a number of other philosophical factors which should now be mentioned, in order to complete this final section of the literature survey. For example, Fischer (1974) points out many of the fallacies and errors in reasoning which some historians have perpetrated. He reveals a number of erroneous analogies, such as historians examining the past using present day values. Fischer also cites cases where historians have attempted to explain historical events about which there is an extremely small amount of evidence or documentation. Perhaps history teachers could be made more aware of this, so that they do not perpetuate such fallacies, or generate potential EFs due to providing limited evidence.

Another noteworthy factor is, in effect, really a dual philosophical and psychological one. This concerns the question 'can human competence

be improved?' Gilbert (1977) suggests that it is possible for the teacher to 'engineer worthy performance'. He proposes that the history of science and philosophy is not a history of error, but a history of gradual approximations to the truth. Gilbert is concerned with what he calls the learner's 'potential for improving performance' (P.I.P.) The P.I.P. is a ratio of the performance of an accomplished or 'master' performer to that of a typical performer (or the performance of a particular subject who is not an expert). He points out that in many walks of life, there is little room to improve on a P.I.P. of (say) 1.09, but considerable potential to improve a P.I.P. of (say) 2.0 or more.

There are numerous examples cited by Gilbert¹ which demonstrate the fact that a small change in behaviour (e.g. the correction of a subject's minor confusion or errors) can promote a large change in accomplishment and improved performance. One example which he quotes, that is worth mentioning here, concerns a Mr. Sloe who performs badly at 'long division' problems. Gilbert shows that his poor results are actually due to only a small error - which Mr. Sloe makes in setting up such problems.

Originally Gilbert (1961) was concerned with a sophisticated system of programmed instruction called 'mathetics'. One central aim of this system is the special design of learning schemes to remove or rectify errors and misunderstandings. Special attention was paid to 'minor' (seemingly small) errors, since it was found that these could lead to major difficulties. Gilbert's (op.cit.) findings in this respect also give further support to the proposition that teachers would do well to look more carefully at the errors of their students.

Finally, it will be useful if a brief reference is made to the theory of 'structural learning'. This approach is based on a scheme of 'rule learning' that embraces 'rules about rules' (or 'meta rules') which was advocated by Scandura (1966).² Nevertheless, the author considers it is doubtful if Scandura's 'rule learning' philosophy would be very successful with many subjects other than mathematics - for which domain it was first devised. However, Scandura does make the following general observation about his theory:

"The distinction between knowledge divorced from behaviour, and knowledge attributable to particular subjects, is basic. The former view of knowledge corresponds directly to the notion of competence as used in generative linguistics. The latter view is more consistent with those of epistemologically orientated psychologists like Piaget where knowledge

1 See Appendix 1 for detailed discussion of this.

2 See Appendix 2 for a more detailed account of this theory.

is directly attributable to subjects..... What the present theory does (amongst other things) is to provide a missing link between these two views".

AIMS AND OBJECTIVES OF THE INVESTIGATION

INTRODUCTION

Certain of the aims and objectives of this investigation have already been outlined earlier in this chapter and in the foreword to the thesis. However, the general aims must now be enunciated and the specific objectives fully explained. Initially, it is intended to offer support for the contention that teachers should look more closely at the obstacles to learning encountered by their students. The literature just reviewed provides definite grounds for this view. Similarly, it is intended to demonstrate the practical feasibility of this viewpoint in this thesis. Furthermore, since the relevant literature in this context is scant, there are clearly many gaps in our knowledge concerning EFs. Hence, an attempt will be made to clarify certain points concerning the nature of error, and also to fill some of these gaps (with respect to the role of EFs in teaching). Nevertheless, since it appears that the whole area of EF theory offers great possibilities for the teacher to improve his teaching, special attention will be given, in various experiments and 'case studies', to the detailed examination of the ways in which EFs could be utilized to aid learning. Moreover, it is intended that this will be a comprehensive investigation, and so the potential role of EFs in general will be examined.

GENERAL OBJECTIVES

A primary objective is to present a detailed theoretical discussion of a wide spectrum of EFs which learners may encounter, and this will then be analysed from a teleological viewpoint. Furthermore, it is hoped to throw new light on EFs and this, in turn, may lead to the promotion of innovation in teaching methods. It is also intended that this innovation will be 'on-going' during the development of the thesis. Yet another general objective will have been satisfied if this thesis helps to establish the need for further research into the matters discussed and provides some direction for future investigations.

It is intended that the analysis of the schemes which will be proposed for the teacher to treat EFs will be both qualitative and quantitative. This is because, at present, there is little evidence or analytical data of any kind to help in the task of assessing the impact of EFs in teaching.

Following this analysis appropriate rationalisation and modification of the various schemes will be undertaken. The fulfilling of this objective will be of help in the formulation of 'model schemes' for treating EFs. These schemes will be subsequently tested experimentally, and the evidence obtained from these experiments will be evaluated using statistical techniques in order to provide a more valid analysis. Hence, by these progressive steps the aim is to provide a comprehensive picture of the techniques which the teacher can employ to treat EFs.

Another general objective is to extend and reinforce the views of Lewis (et.al.) regarding the advantages to be gained by educationalists thinking more carefully in terms of EFs. Moreover, there is some evidence, which is revealed in the literature, that there is no clear idea, amongst the investigators of 'learning difficulties', of the forms which an error can take (i.e. they assume that the underlying source of confusion is generally unpredictable). Hence, it is another general objective of this enquiry to discover if it is possible to determine the forms which an EF may take, and then to suggest means of identifying these forms which the teacher could use. Such a facility could also prove to be a valuable weapon for the teacher in his fight to help students learn more effectively.

There have been a number of instances cited in the literature, that reveal the unfortunate consequences which the teacher's ignorance of EFs can produce. Moreover, the situation at present is particularly unfortunate, since it not only involves the lost potential of powerful strategies to aid learning but also the restrictions and failures associated with teachers' ignorance of EFs. Consequently, it is a further general aim of the investigation to indicate some of the significant opportunities and challenges offered by this vast and largely unexplored area of learning theory. However, in addition to these general aims outlined in this overview there are a number of specific objectives which must now be presented.

SPECIFIC OBJECTIVES

Since research in the field of EFs has so far been somewhat limited, a fundamental objective of this enquiry is the fabrication of meaningful terminology to enable EFs to be clearly defined and discussed. Moreover, after certain groundwork has been undertaken, various hypotheses concerning the properties of EFs will be formulated. This objective requires a critical examination to be undertaken of all aspects of EFs in general, not just in the classroom. It is hoped to promote a balanced view about the function of EFs in teaching. Certain implicit objectives, such as the appraisal of some teaching methods are associated with this specific aim, and so these

must also be satisfied. In addition, questions about where or when particular EFs are most likely to occur in the learning context will be examined.

A particularly important specific objective is the construction of some preliminary schemes for EF detection, diagnosis and rectification by the teacher. However, there are also certain problems concerning the resolution of EFs which require investigation, and possible ways of achieving this resolution must also be devised. Similarly, provision of some workable criteria regarding how and when the teacher should employ EF strategies is required. Furthermore, as there is some evidence to suggest that certain 'teaching strategies' contain weaknesses with regard to treating errors, these will be investigated (as will any possibly unfounded presuppositions which teachers may have in this respect).

The provision of efficient strategies for treating learners' EFs requires that these should be classified in some way. A scheme for classifying EFs will thus be proposed, and its employment in teaching will then be fully investigated. Another specific aim of this investigation is the provision of certain empirical data and other evidence which will clearly illustrate the significant potential of EFs for exploitation by the teacher to aid and accelerate learning (or overcome certain learning difficulties). It is axiomatic that some errors in the learning situation are to be avoided and so this requirement will also be thoroughly examined here. Moreover, strategies will be devised for this purpose and tested with different groups of students. Finally, it is intended to suggest guidelines for the provision of an adaptive 'framework' for the treatment of EFs by the teacher. In order to fulfil these specific objectives a radical approach to the whole subject of errors in learning will be adopted.

PLAN OF STUDY

While attempting to contribute to knowledge concerning EFs it is also planned to demonstrate what powerful tools for enhancing learning they can be. In this way it is intended that the thesis will assume the function of a catalyst to stimulate even more extensive and protracted investigations in future. With this plan in mind various techniques for treating EFs will be presented and assessed for use in the classroom. The application of these techniques will then be supported by analysis of the empirical data and anecdotal evidence which will be obtained from pilot experiments and a major experiment. Much of the experimental investigation will be related to the teaching and learning of physical sciences or mathematics. Neverthe-

less, it is expected that the extrapolation of the evidence and observations into other disciplines will not prove too difficult. In the next chapter some preliminary theories concerning the nature of EFs will be postulated. Following this there will be an initial examination of the practical ways in which the teacher can use EF strategies to assist the learning of his students.

Having set the scene, it is then planned to demonstrate that, while EFs are 'blockages' to learning, by using certain strategies they can be employed by the teacher as blocks from which learning can be built. As Harlow (op.cit.) has observed, EFs can be motivational factors. Hence, it will subsequently be demonstrated that they can be usefully employed for this purpose by the teacher. This will be shown in the various 'protocols' which will later be presented. There is some evidence cited in the literature that it is often important for errors to be quickly detected and then rectified. Thus, in a later chapter, various means of carrying out this requirement using special techniques which the author has devised, such as the electronic 'feedback classroom'¹ (shown in Plate 1) will be discussed.

After examining the nature of EFs, with the object of formulating theories concerning their origin and occurrence, an analysis will be undertaken to discover which situations are likely to lead to a marked generation of EFs. Associated with this will be an enquiry to determine the conditions which may lead to changes in EFs. It is considered necessary to clear up these points before contemplating and then formulating a scheme for EF classification. Such a scheme is an essential part of any strategy for treating EFs, since if the teacher is unable to classify the EFs of his learners he is not in a position to undertake systematic EF treatment with any degree of reliability.

This will be followed by an analysis of the problems of EF removal and correction. Ways of achieving this, such as the use of 'teachback', will be examined and suggestions made regarding their relative suitability. Various strategies for EF avoidance will then be investigated, such as the use of algorithms and the employment of 'telling' strategies for EF prevention. Objective conclusions and subjective appraisals will later be presented, concerning all the examples and experimental evidence obtained in the investigations, with the aim of rationalising the role of EFs in teaching. Finally, the thesis will conclude with some element of speculation concerning this role and suggestions will also be made regarding future directions of research.

1 See Appendix 3 for details of this system.

Mobile Electronic 'Feedback Classroom' Unit

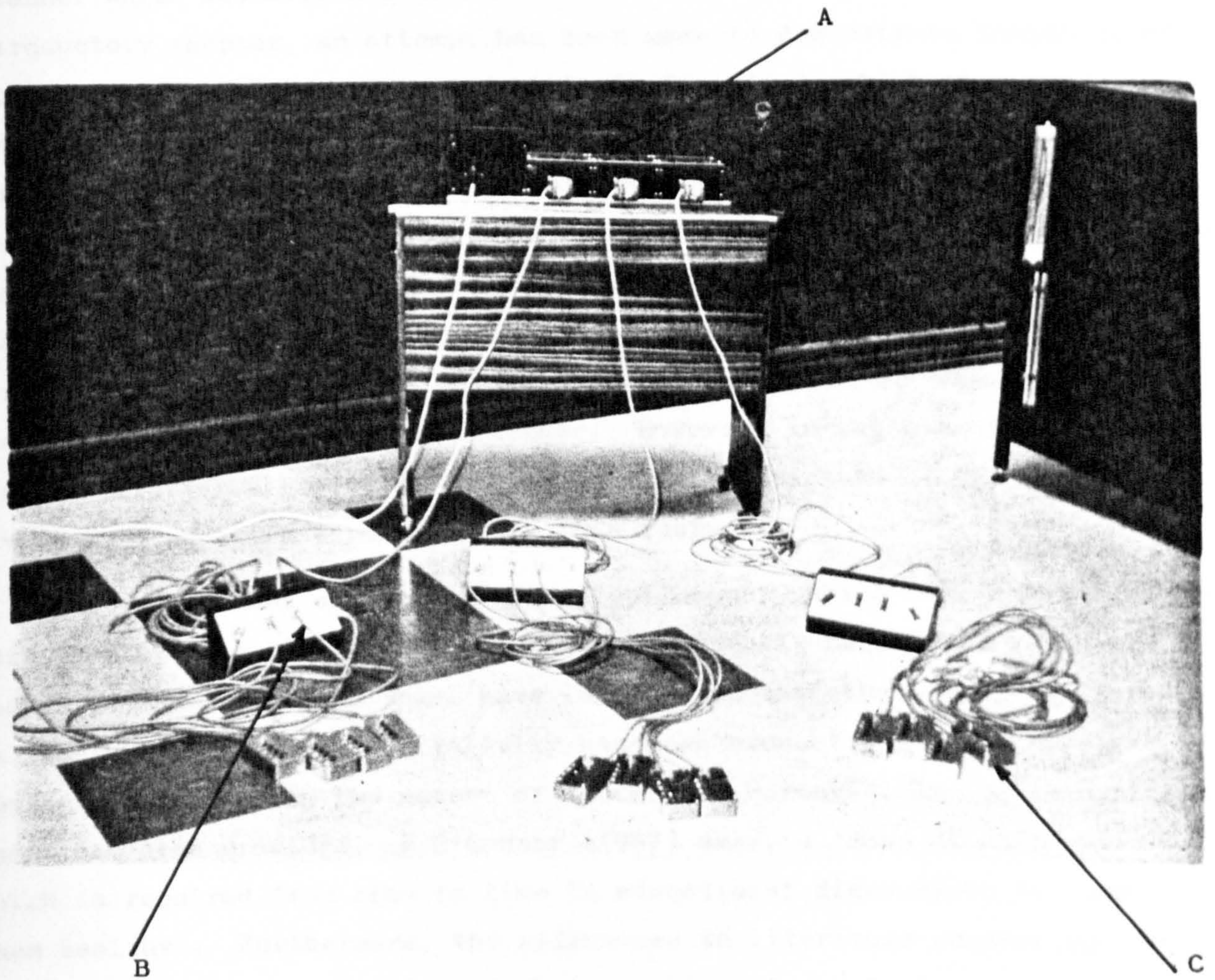

PLATE 1

Key:

- A - Master Console
- B - Terminal Unit
- C - Response Unit

N.B. One 'terminal Unit' feeds 4 student 'response units' (normally placed on desks or benches)

SUMMARY AND CONCLUSIONS

It is evident from the literature survey that the concept of EFs is in an embryonic state at present. Therefore, it will require careful nurturing during this investigation so that it can be developed to fuller maturity in a manner which educationalists should find most fruitful. In this introductory chapter, an attempt has been made to demonstrate something of the potential, that was advocated by Lewis (op.cit.), which this concept has for exploitation by teachers. It has also been revealed that EFs remain as somewhat of an enigma to many of those involved in education. Earlier in this chapter it was established that some attempt must be made to display those properties and facets of EFs which the teacher could find of practical help in his teaching. Some definitions and descriptions of EFs were also presented and this exegesis later proved helpful when discussing the concept in relation to the teacher. However, in subsequent chapters further efforts will be made to provide a fuller picture of EFs and to devise more specific terminology in this respect.

The dual themes of psychology and philosophy, which will run throughout this thesis, have already been found to be mutually beneficial in this enquiry. Aspects of one theme have impinged on the other, and vice versa, so that a greater depth and validity has been brought to the proposals (especially regarding the nature of 'error'). Moreover, the philosophical theme has also provided, as O'Conner (1957) says, a 'dose of antiseptic which is required from time to time in educational discussions to keep them healthy'. Furthermore, the references to literature concerning hermeneutics and the validity of theories have also helped to provide a clearer background to this enquiry.

A further important conclusion, which has emerged from this introductory chapter, is that there could be a special relationship between EFPs (Error Factor Producers) and problem difficulty. Similarly, it now seems that the causes of misunderstanding, and the factors which students find difficulty with in their learning, are not as straightforward as might first appear. Hence, it seems that some teachers could be subjecting their learners to treatment which is either inadequate or inappropriate to deal with their errors and misunderstandings. Another significant implication which has emerged is that it is not only possible to devise strategies for exploiting EFs to enhance learning, but it is also possible to employ techniques (such as algorithms) to prevent the occurrence of undesirable EFs.

In summarising the main points of this introductory chapter it must not be forgotten that much of its content, like that of the remainder of the thesis, is exploratory. This is considered to be the most satisfactory approach to adopt because no real basis for analysing or assessing the role of EFs in teaching exists at present. Moreover, after appraising the overview of the aims of this investigation it appears that there is much in the notion of EFs to interest all those associated with 'education' in its broadest sense. Hence, if hypotheses concerning the nature of EFs are subsequently proposed, and strategies for treating these are devised (which can be adopted by teachers) then this project will have made a modest contribution to learning theory - both in terms of epistemology and precept. This investigation will have also played a further important part if it initiates fresh objectives for future educational enquiries and experimental investigations concerning EFs in all learning situations.

It was indicated earlier in the chapter that there is some literature on teaching and training which makes certain references to the problems of identifying and eradicating errors. However, it must now be stressed that most of these references tend to be 'content specific'. For instance it was reported that investigators of language teaching have observed the kinds of errors which students make in 'second language' learning. Unfortunately, they have not embedded these insights in any general 'theory of error'. In fact, it is now evident that 'error' itself is rarely made the subject of self-conscious theoretical investigation. In consequence, the insights that, say, language teachers have, on the matter of error, do not in any way illuminate the insights that other teachers (e.g. mathematics or science teachers) have on this matter. Therefore, at the present, in the absence of any unifying approach each discipline is obliged to cope with the problem of error in its own usually ad hoc way.

It has proved to be expedient that this undertaking is partly a 'ground clearing' exercise, since it is evident that little significant investigation has previously been afforded to this area. What literature there is on the subject mainly points out the numerous problems, without any real attempt being made to suggest ways of dealing with them. Some of this literature has also been found to be inconsistent with regard to the treatment of learners' errors, and so this enquiry must take account of this situation. Moreover, it seems that an attempt should be made in this thesis (using practical examples) to build up a reasonably convincing case for the view that terms such as 'confusion', 'misunderstanding' and 'error' do not describe learners' behaviour - but, rather, pass judgement on it.

Furthermore, regarding 'errorless' learning strategies it appears that these do not have the same qualities or potential which paradigms based on EF theories offer the teacher.

Although the aims and objectives of this investigation have been outlined in this chapter, various additional objectives may emerge after the observations of the pilot experiments have been analysed. Similarly, it was indicated in the plan of this study that from time to time some speculative conceptual schemes will be sketched; perhaps this should also be undertaken with the further aim of supporting the conclusion that a more intensive review of this topic is an important objective for future research. A final conclusion which has emerged in this chapter is that the function of EFs in teaching should also be examined from a 'functional' viewpoint - so that their role becomes more clearly exemplified. All these conclusions and implications along with the numerous suggestions concerning EFs made throughout this chapter, will be examined further at appropriate stages of this thesis.

CHAPTER 2

A detailed examination of EFs.

INTRODUCTION

To assist the theoretical discussions which will follow in this chapter it may be helpful to consider a few real life examples of students' EFs. Each of the 'protocols' which will be examined for this purpose has been chosen to reveal or illustrate important points. The conclusions drawn in respect of the protocols will be taken into account in the formulation of preliminary hypotheses concerning the nature of EFs and their role in teaching. Some of the cases to be examined are also intended to illustrate aspects of the formation of EFs, and the ways in which they can originate.

Wallen and Travers (1967) feel that it is often not clear what causes a learner's misunderstanding, and therefore it is difficult for the teacher to decide what measures he must take to help the learner. This chapter will suggest ways of helping to resolve some of these problems. The suggestions that are made will be reinforced by accounts of cases that reveal the effects that inappropriate measures can have in exacerbating learners' difficulties. All these examples and subsequent proposals are intended to support the view that teachers could do much more to prevent and/or detect and/or alleviate students' EFs.

Both the origins of EFs and the conditions which can lead to their becoming more firmly established will be fully discussed. The detailed 'case studies' of various EFs, which will be provided here, are intended to exemplify how EFs can be used to make teaching more effective and to establish the concept of 'learning by errors'. The first of these 'case studies' is based on a case described by Lewis (1966). It relates to errors and misunderstanding in arithmetic (decimal multiplication).

CASE 1

A 10 year old student, when asked to find the product of 0.3 and 0.3, gave the answer as 0.9 (the correct answer should be 0.09). However, this student's error was repeated when he

was asked for the product of 0.2 and 0.3. He gave 0.6 as the answer instead of 0.06. There was clearly some misunderstanding in the student's mind concerning "the handling of the decimal point in decimal multiplication" and it seemed probable that the misunderstanding would result in further errors being made. Follow-up questions confirmed that this was the case. The student went on to say that $0.2 \times 0.2 = \underline{0.4}$. And so on.

Instead of the teacher correcting each one of these errors as they arose it would seem to be both more effective and more insightful to rectify the underlying dimension of confusion (i.e. 'error factor'). Thus, by one process the teacher could clear up all errors arising from the same basic source of confusion. When doing so the teacher should indicate to the student that this single factor has caused all the associated errors - so that he becomes both more motivated and aware of what he must do in future (hence transfer of this new understanding will then be maximised). The case described above is typical of many which the author also observed in 'mature' learners. If underlying causes of confusion are not detected and pointed out to the students, their confusion may continue, unrectified, throughout the whole of their studies.

Sometimes a capable learner is found to be experiencing what Wood (op.cit.) calls 'subject disabilities'. These are special difficulties which the learner has only in particular subjects. Wood cites a 'case study' of this type with regard to an 11 year old boy called Paul, who was good at reading, English and so on, but poor at arithmetic (and so he eventually disliked it). The general opinion of Paul's teachers was that he had no ability in arithmetic. However, careful analysis of his weaknesses in arithmetic reveals something that his teachers did not appreciate.

CASE 2

Paul was asked to multiply 6 by 4. He gave the answer that $6 \times 4 = 25$. The same error was observed when he was asked to multiply the reverse i.e. 4×6 (which he also said equals 25). Thus, Paul's error in this respect was consistent and cannot be dismissed as a random mistake. Since Paul correctly said that $5 \times 4 = \underline{20}$ it was not all multiplication which he found difficult but only some. (Perhaps originating from a simple misunderstanding).

Wood reports that, when Paul eventually discovered that his difficulties were all due to the making of a few 'basic errors' which could easily be put right, his motivation was sharply increased (and soon afterwards these errors were rectified).

In this 'case study' there are two points regarding EFs which are of special interest. First, the fact that EFs can play a powerful motivational role. Secondly, that ignorance concerning the origin (and effects) of basic elements of confusion caused Paul's teacher to draw invalid and damaging conclusions about his ability in arithmetic. Had this situation been recognised earlier Paul would not have felt a failure and the whole situation would not have been exacerbated by his teachers.

This case clearly reveals the need for teachers to be provided with diagnostic techniques so that they can undertake EF analysis and treatment. While Paul was obviously neither a fool nor a polymath, Wood recognised that he did have 'latent' ability in arithmetic. So he tried to discover the reasons lying behind the errors that Paul was making. It is interesting to speculate what may have happened if Wood had not become involved in this case.

PRELIMINARY CONCLUSIONS

Analysis of the two 'case studies' previously described indicates that both students and their teachers may be ignorant of the often simple underlying cause of student misunderstanding and error. The unreflective teacher could condemn the learner as being a failure in both of the 'case studies' previously described. Yet each of these cases is a concrete example of how EFs might be exploited to the advantage of the learner. Unfortunately, the unreflective teacher would not appreciate the true significance of these situations, and thus valuable opportunities to enhance learning are then missed.

The teacher who is aware of the basic properties of EFs and has schemes for treating them, would have diagnosed both cases, and treated them with very little difficulty. It is an easy exercise, having identified the underlying EFs in either of the two 'case studies' given earlier, for the teacher to carry out rectification.

MEANS OF IDENTIFYING EFs

CASE 1

It is clear in Case 1 that a definite error has been made. The next step is to discover if this is just a slip of the pen, (i.e. the decimal point was accidentally put in the wrong place) an isolated mistake, or one of the whole range of similar errors. The teacher should not assume any of these possibilities at this stage without further confirmation (yet it has been the author's observation that some teachers do make assumptions and often erroneous ones, under such conditions). In order to discover which of the above alternatives applies the teacher must give the student a number of associated decimal multiplication problems to answer. In addition, the learner must be asked to say why he gives particular answers to these new problems. It will be assumed, for the moment, that the learner in Case 1 has not made either a slip of the pen or an isolated mistake. Hence, it is observed that he gives incorrect answers to all the new decimal multiplication 'test questions' which he is given. The questions are of the following form:

(i) $0.2 \times 0.4 = \underline{0.8}$ (i.e. wrong again)
(since answer should be 0.08)

(ii) $0.2 \times 0.2 = \underline{0.4}$ (i.e. wrong again)
(since answer should be 0.04)

In each case, as in the original examples, the student's error is the same, namely that the decimal point is in the wrong place (and so each of his answers is consistently 10 times too great). Thus there is a common element of error in each of these cases (i.e. there is an underlying EF). This can be further confirmed by asking the learner to explain his method and the reason for his answer. A typical reply in this situation is that, since $2 \times 4 = \underline{8}$ then $0.2 \times 0.4 = \underline{0.8}$ (because it is suggested that only the decimal point is different in the two problems). In other words, the learner has not been told, or he has failed to see, that in the case of multiplying decimal fractions the answer must always be smaller. The question now is how can these errors best be

rectified to enhance learning? A special procedure will be presented, after first diagnosing and identifying the EFs in 'Case Study 2'.

CASE 2

To identify the presence of EFs in the case of Paul, a similar preliminary procedure to that described with reference to Case 1 will be employed, in order to make sure that these are not just isolated mistakes but are what Smith (op.cit.) calls 'constant errors'. Hence, he was asked the following questions for this purpose.

- (i) What is 7×8 ? (he said = 54)
 - (ii) What is 8×7 ? (he said = 54)
(i.e. error in (i) is consistent)
 - (iii) What is 9×9 ? (he said = 72)
- And so on.

Since the error of 7×8 and 8×7 was consistent, and in the original examples of 6×4 and 4×6 a consistent error was also observed, it appears that there is some basic source of confusion operating. When asked the reason for his answer that 6×4 (or 4×6) = 25 he said that he first worked out $5 \times 4 =$ 20 (which is correct). So it is therefore, not all multiplication problems which Paul could not answer correctly, only some problems. Therefore, he was next asked to work out 7×8 , and also 8×7 , to check the consistency of error. The reason for doing this was to assess the extent and nature of his misunderstanding. (Having checked earlier to see if he could add and subtract correctly - before concluding that something was wrong with his ability to multiply). This exercise was undertaken to make sure that Paul had made a definite error (i.e. to ensure that he really was under the impression that 6×4 should = 25 not 24). It thus seems that, from the teacher's point of view, Paul has an erroneous concept of 'sets' in arithmetic.

When asked to explain how he obtained the answer 54 to the problem 7×8 , Paul was observed to use a similar erroneous

procedure to that used in the earlier examples. In this case he explained that he knew $6 \times 7 = \underline{42}$, and $2 \times 6 = \underline{12}$, so he added 42 and 12 which gave the answer 54. Again this error may stem from an incorrect 'set' concept, because Paul did know the correct multiplication of 6 and 7 as well as 2 and 6. Therefore, it was not multiplication in general which Paul misunderstood, but a number of specific multiplication problems. What is significant in this case, is that again all these errors probably result from the same basic misunderstanding or EF which probably caused Paul to make incorrect 'set' groupings i.e. between $5 \times (4)$ and $6 \times (4)$, or $6 \times (7)$ and $8 \times (7)$. The sad lesson here is that Paul's teachers had failed to identify this situation, and so concluded that he did not have the innate capacity necessary for success in arithmetic. Among other things, they assumed that he was "pretty hopeless" at arithmetic and was "only guessing" the answer.

N.B. Wheeler (1977) has undertaken a number of similar studies of mathematics learning (in British schools) and reports many examples which parallel that described in Case 2.

PRELIMINARY TECHNIQUES FOR EF RECTIFICATION

CASE 1

Having established that a definite EF is operating, using the strategies devised for this purpose; EF rectification procedures can now be carried out. However, the aim is not merely to rectify the particular errors in this case, but to clear up a whole cluster of associated errors arising from the underlying dimension of confusion in the same process. Lewis (op.cit.) remarks that the unimaginative teacher would, in the case of the decimal multiplication errors, probably reiterate 'the Rule governing the use of the decimal point'. However, if the teacher put arrows over both the multiplicand and the multiplier it may help to remind the student that $\overrightarrow{0.3} \times \overleftarrow{0.3} = 3 \times 0.03$ which gives 0.09 - the correct answer.

Unfortunately, the above procedure might well fail to provide the student with any real conceptual understanding of the process of decimal multiplication. It is important for the learner to see why 0.3×0.3 equals 0.09 (rather than 0.9), if the procedure is to have any real meaning for him. The teacher should also ensure that the learner understands the meaning of the multiplication sign in this context. If these conditions are not satisfied then he will just view the procedure as a process to be followed blindly and he will not be able to transfer or adapt it to other problems, due to his lack of general understanding. Hence, the learner would have to play around with similar problems for some time, so that he eventually understands why the product of two decimals is unchanged when the respective decimal points are shifted in mutually compensatory directions, as demonstrated in the above example.

The author suggests that the learner could be given the necessary insight by an imaginative teacher giving him these decimals in the form of actual 'fractions'. The process of

conversion is quite simple and the learner will quickly see that 0.3×0.3 is the same as $3/10 \times 3/10$. It is easier, when written in this form, for him to perceive that $3/10 \times 3/10 = 9/100$ which in turn is equal to 0.09 on reconversion. Written in fraction form it is, therefore, also more likely that the learner will comprehend that $3/10 \times 3/10$ equals $3 \times 3/100$ (which is the 'fraction' form of the previous assertion that $0.3 \times 0.3 = 3 \times 0.03$). The use of this duality technique has an added value in that it encourages the learner to appreciate that decimals and fractions can be interchanged - which he can use as a tool for solving other problems.

EF EXPLOITATION

It was suggested earlier that the rectification of EFs could be exploited to enhance learning, by the employment of certain strategies and techniques. This can be illustrated by reference to the EF rectification possibilities in Case 1. For instance, the teacher could show the learner that, when moving the decimal points in the equation in equal and opposite directions, one factor is being multiplied by 10 and the other divided by 10. Hence, the balance of the equation is unchanged and the product remains the same. The teacher could extend this new understanding to embrace the fact that the same procedure can be employed with any number (apart from 10). He could show that the procedure would be unaltered if 3 was used instead of 10. (I.e. dividing one factor by 3 and multiplying the other by 3, so that 0.3×0.3 becomes 0.1×0.9 , which still gives the correct answer 0.09). Hence, the teacher has elucidated a general principle, which the learner can benefit from comprehending, in addition to rectifying the learner's basic misunderstanding.

Nevertheless, the author believes that the reflective teacher could do still more in this respect by helping the learner to analyse the inherent reasonableness of this general principle of arithmetic. He may do so by:

- (a) Demonstrating that, when multiplying decimals or fractions which are each greater than unity, then the product is always greater than either the multiplicand or multiplier. e.g. 3×3 (both greater than unity) equals 9 (which is greater than either the multiplicand 3 or multiplier 3).

- (b) Demonstrating that, when multiplying decimals or fractions which are each less than unity, then the product is always less than either the multiplier or multiplicand. e.g. 0.3×0.3 (both less than unity). Now if this equals 0.9 (as the learner asserted) it means that the product is greater than either the multiplicand, 0.3, or the multiplier, 0.3, so the answer 0.9 is definitely wrong.

The teacher could also help the learner to identify his confusion by using a technique of conflict. In this case the student could be asked to give the answer to 0.3×3.0 . If he answers 0.9 it will cause him to question his answer to the original problem of 0.3×0.3 which he also gave as 0.9. This technique could then be expanded so that the learner obtains a more general picture of his misunderstanding.

In a case such as this the author endorses Lewis's (op.cit.) suggestion that the learner be given further proof that an answer such as $0.3 \times 0.3 = 0.9$ is wrong, in order to reinforce his understanding of the correct concept. One way of achieving this objective which the teacher might employ is the use of a visual aid, such as a 'pie diagram'. With the aid of this diagram he could demonstrate that 0.3 i.e. 3/10th's of¹ 0.3 (which is also 3/10th's) is a 'fraction of a fraction', and thus is a smaller portion than the original 0.3 or 3/10th's. From this exercise the learner would appreciate that, since 0.9 (i.e. 9/10th's) is a larger portion than 0.3, then it cannot be the correct product of 0.3×0.3

This line of reasoning could be further reinforced by the teacher asking the learner what 1×0.3 equals. If his answer is that $1 \times 0.3 = 0.3$ he could then be asked what 0.1×0.3 equals. If he says that this equals 0.03 then his correct answer should be endorsed, and the teacher should point out to him that 0.03 is 10 times smaller than 0.3. Hence, since 0.3 is three times larger than 0.1 the answer to 0.3×0.3 must be three times larger than 0.03. The teacher has now helped the learner to conclude by himself

1 The teacher must ensure that the learner understands the meaning of the word 'of' in this context. (i.e. its "equivalence" to the multiplication sign in questions of the kind: What is 0.3 of 0.3? What is 0.3×0.3 ?).

that the correct answer is 0.09 not 0.9. By pointing out again to him that 0.09 is smaller than 0.3 (which is in keeping with the basic premise) the teacher will then have merely to demonstrate the universal applicability of this condition to resolve all the learner's previous errors in this respect. This approach to EF exploitation could be adapted by the teacher to suit different levels of ability, and simplified for use with learners who have not yet come to understand 'proportion' in this context.

PRELIMINARY TECHNIQUES FOR EF RECTIFICATION

CASE 2

It is important to state that the procedures which follow must not be carried out until the EF has been confirmed and diagnosed. This operation has already been explained and carried out earlier in this chapter. Hence, various ways will now be suggested in which the reflective teacher may help the learner Paul by clearing up the EFs responsible for his errors in arithmetic.

When Paul was asked to explain why he said that $6 \times 4 = \underline{25}$, he explained that he worked out $5 \times 4 = \underline{20}$, and thought that another '5' was needed. For this reason he added 5 to 20 which gave the answer 25. A similar error was committed with respect to 7×8 which he said equals 54. In this case he explained that he knew $6 \times 7 = \underline{42}$ and also that $2 \times 6 = \underline{12}$. So he added 42 and 12 which gave 54. To rectify the underlying cause of this confusion it is necessary to first show Paul why he is wrong. This could be done using 'sets' of counters. It is clear that he has the ability to add or subtract numbers, so this could also be employed using these 'sets' of counters.

What the reflective teacher, who is aware of EF strategies, could do is to ask Paul to count out say 6 'sets' each of 4 markers (i.e. 6 by 4) and 5 'sets' of 4 markers (i.e. 5 by 4). Then he should be asked to count the total number of markers in the 'set' of 6 and then in the 'set' of 5. Thus, he could be told that 6 by 4 is the same as 6×4 . Hence he would discover that $6 \times 4 = \underline{24}$. However, this only teaches him the correct answer without explaining it. To facilitate explanation and understanding, Paul could be asked to subtract the total he got for the set of 5 \times 4 from the total

he got for the set of $\underline{5} \times 4$ from the total of $\underline{6} \times 4$. He would then discover that the difference (i.e. $24 - 20 = \underline{4}$) is a common 'set' of 4's (i.e. ' $\underline{6} \times 4$ ' and ' $\underline{5} \times 4$ ') not the uncommon 'set' of 5's (or 6's) which caused his errors.

Hence, Paul will not only have learned the correct answer to the specific problem of 6×4 (or 4×6) but also he will have learned a more general concept of multiplication - in the same process of the error removal. Paul will thus have seen for himself why his answers were wrong and the above answers are correct. The author suggests that this understanding is more likely to persist than if the teacher had merely told him the correct answer. There is evidence to suggest that many teachers actually do this. For example, to assist Paul in his confusion Wood (op.cit.) gave him a 'Trouble Book' containing a note of his errors and the correct answers to the problems - it is unfortunate that Wood was not really aware of EFs and so did not use the above strategies to rectify Paul's difficulties in a really effective way. More sophisticated procedures for extending and enhancing learning will not be discussed at this point, because the object in this and the previous 'case study' has only been to demonstrate simple steps that teachers can take concerning the EFs of their students.

THE CAUSES OF EFs AND THEIR EXPLOITATION

The following 'case studies' 3 and 4, are intended to illustrate how the unreflective teacher often promotes EFs in his teaching. It will then be demonstrated how other, more reflective teachers (who have been given a full understanding of EFs) can either avoid promoting them or exploit them to enhance learning. Both of the cases have been chosen from the learning of 'geometry' - since this subject involves both practical skills (which are necessary for carrying out geometrical constructions) and comprehension (of geometrical theories). In each of the two cases it will be made clear:

- (i) what it is that the teacher wants to help the student to learn,
- and (ii) how this can be achieved using special EF strategies.

CASE 3

A group of 12 students aged 11 years were asked to construct a 'cross' and then say how many right angles the 'internal' angles of this cross added up to. Some 9 students constructed crosses like that shown in Figure 4 and the other 3 produced crosses like that shown in Figure 5.

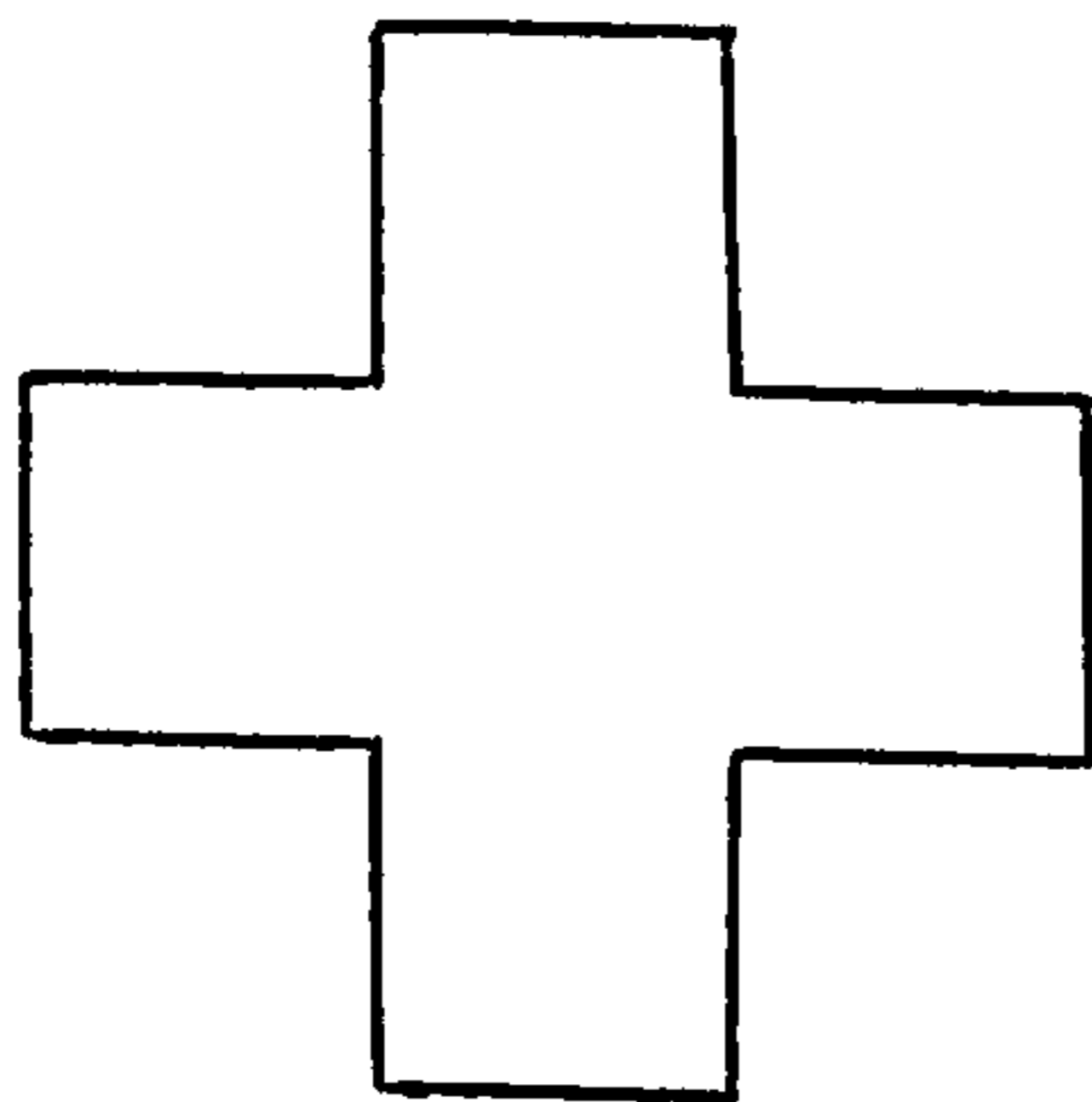

FIGURE 4

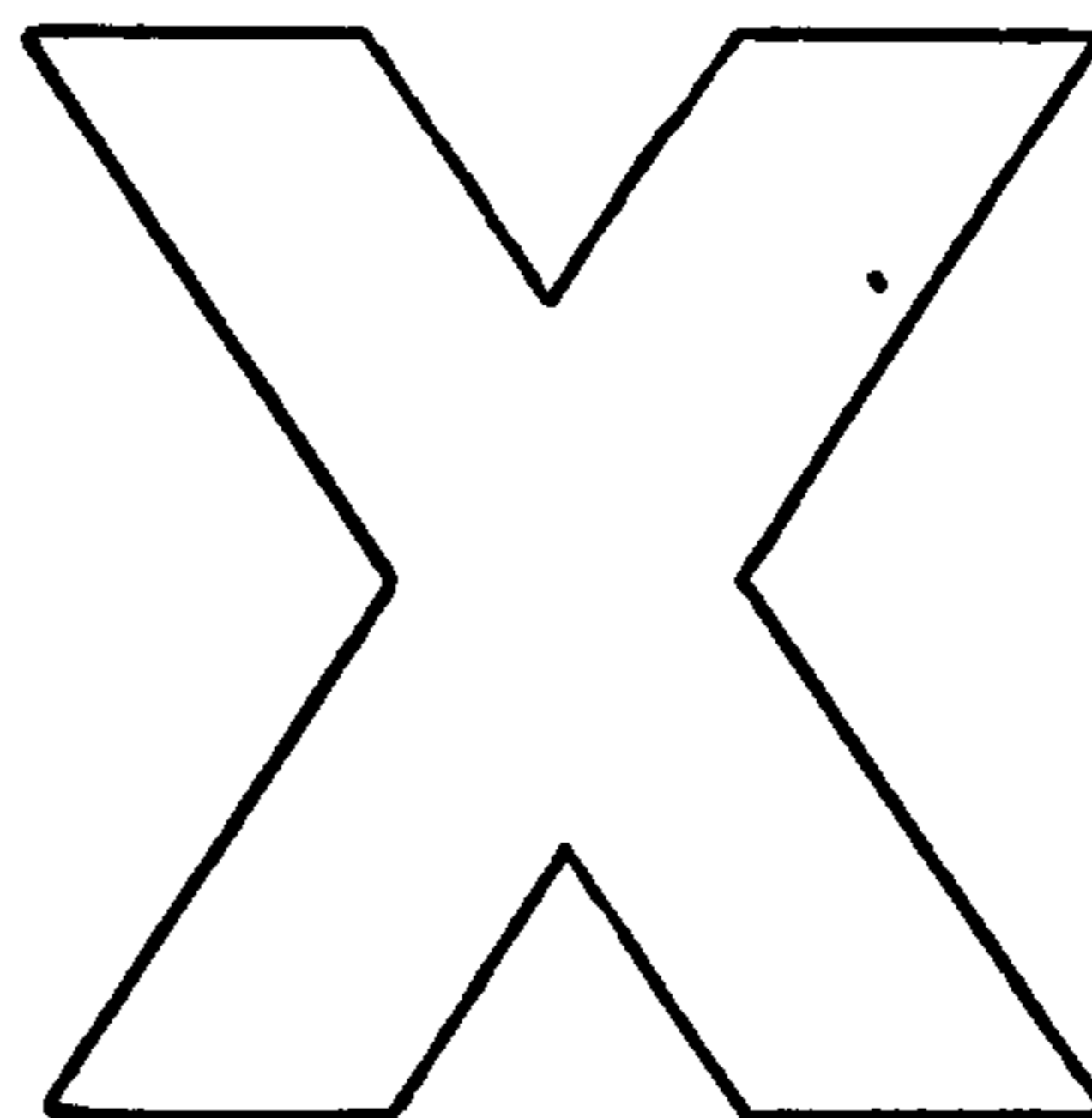

FIGURE 5

The cross represented in Figure 4 is what the teacher intended the students to construct. Thus the teacher, who was not aware of the possible misinterpretation of his instructions has introduced confusion and possible EFs. As it happens, the internal angles of figures 4 and 5 both sum to 20 right angles. However, the students were aged only 11, and were therefore not being asked to obtain the answer of 20 right angles by calculation (e.g. from an algebraic formula). Instead, they were expected to draw a figure of the kind shown in figure 4 - so that they could secure an answer by visual inspection and counting. It is therefore essential that the 3 students who drew the cross shown in Figure 5 are told that their diagram is inappropriate, and are then clearly informed what they should have constructed. At the same time, the teacher must avoid giving the erroneous idea that what they drew was not a cross. Figure 5 obviously is a cross, but is not a cross of the kind that the teacher intended. The teacher who is aware of EF strategies would have avoided this problem, by making it clear before-hand what form of cross he wished to be constructed.

Assuming that all the students have now constructed the appropriate cross, further errors could still arise in their answers to the question of the total number of 'internal' angles. Some learners could examine the figure and say that the answer is 8 right angles (i.e. 1 - 8 in Figure 6). They will have failed to see that the figure also includes 4 treble right angles (labelled a, b, c and d in Figure 6.)

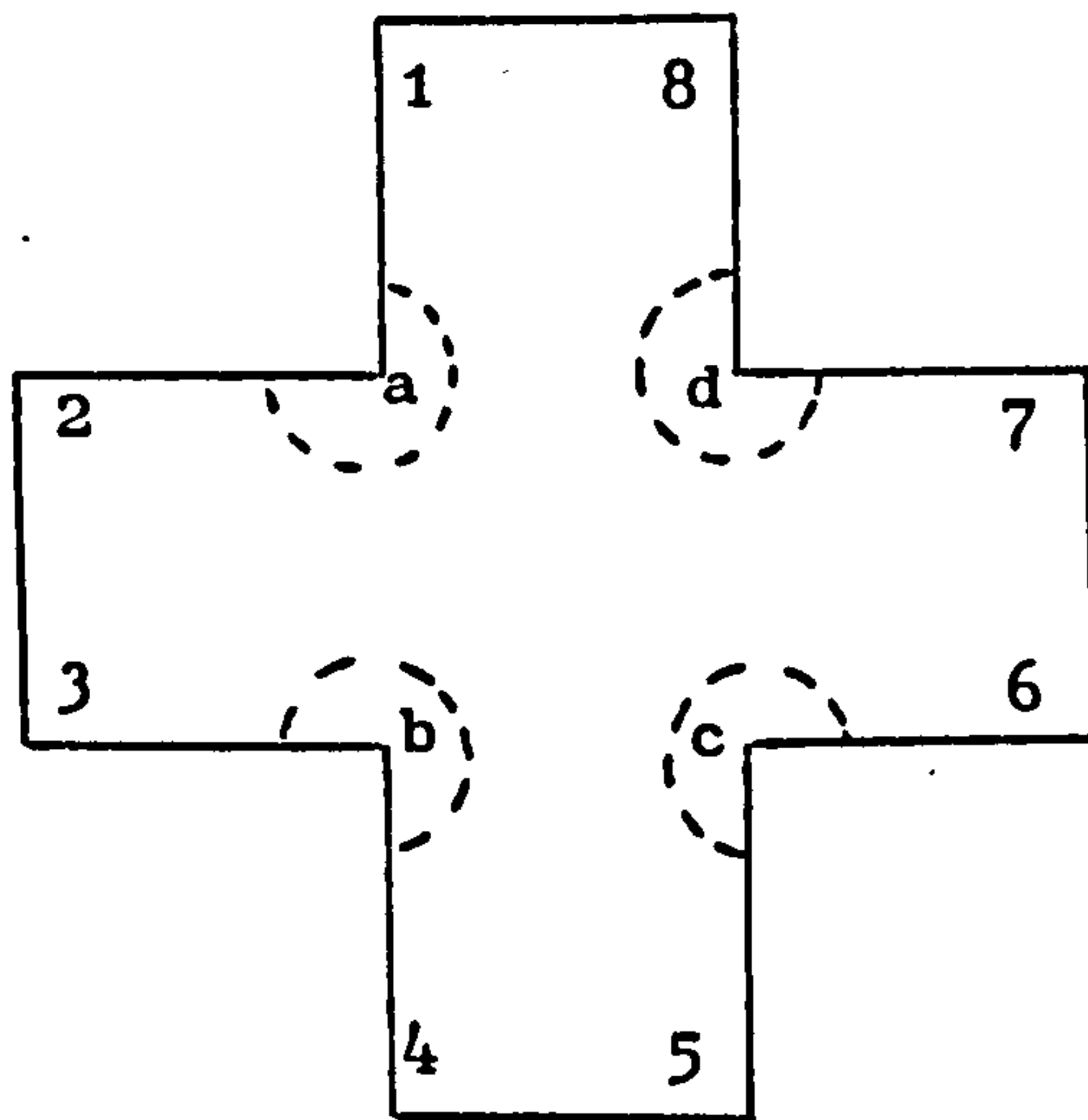

FIGURE 6

The more reflective teacher would point out to his student that the figure has more than 8 internal angles, and explain why there are 4 treble right angles also in the figure. In this way he would not only bring the students to understand that this figure contains 12 'internal' angles which collectively sum to 20 right angles, but at the same time he could also clear up some general misunderstandings concerning the geometry of right angles. The learner could also extend this new understanding to other angles and 12 sided figures. The teacher could also tell them how to devise the formula for this (which is: Number of right angles = $2(n-2)$, where 'n' is the number of sides of the figure), once they have learned basic algebra. Another lesson, which this 'case study' provides, is that the teacher must not make any assumptions about his students' understanding, without first checking this. As already demonstrated the origins of many EFs are often due to incorrect assumptions being made by uninformed teachers. Thus, the teacher who is ignorant of EF theory is not only depriving himself (and his students) of a powerful tool which could help them to learn, but he may also be guilty of either promoting or reinforcing these obstacles to their learning.

CASE 4

This case is a particularly interesting one in the context of this investigation into the role of EFs in teaching. It is one in which the student has to carry out some geometrical construction, and then investigate some theoretical aspects of it.

Initially the group of students were asked to draw a circle and then construct a chord 'BA' as shown in Figure 7 below (i.e. they were shown what their construction was intended to be like). They were then told to take the mid point - 'P' of this chord 'AB' and construct any other chord which passed through the mid point. A typical illustration of the students' constructions is given in Figure 8.

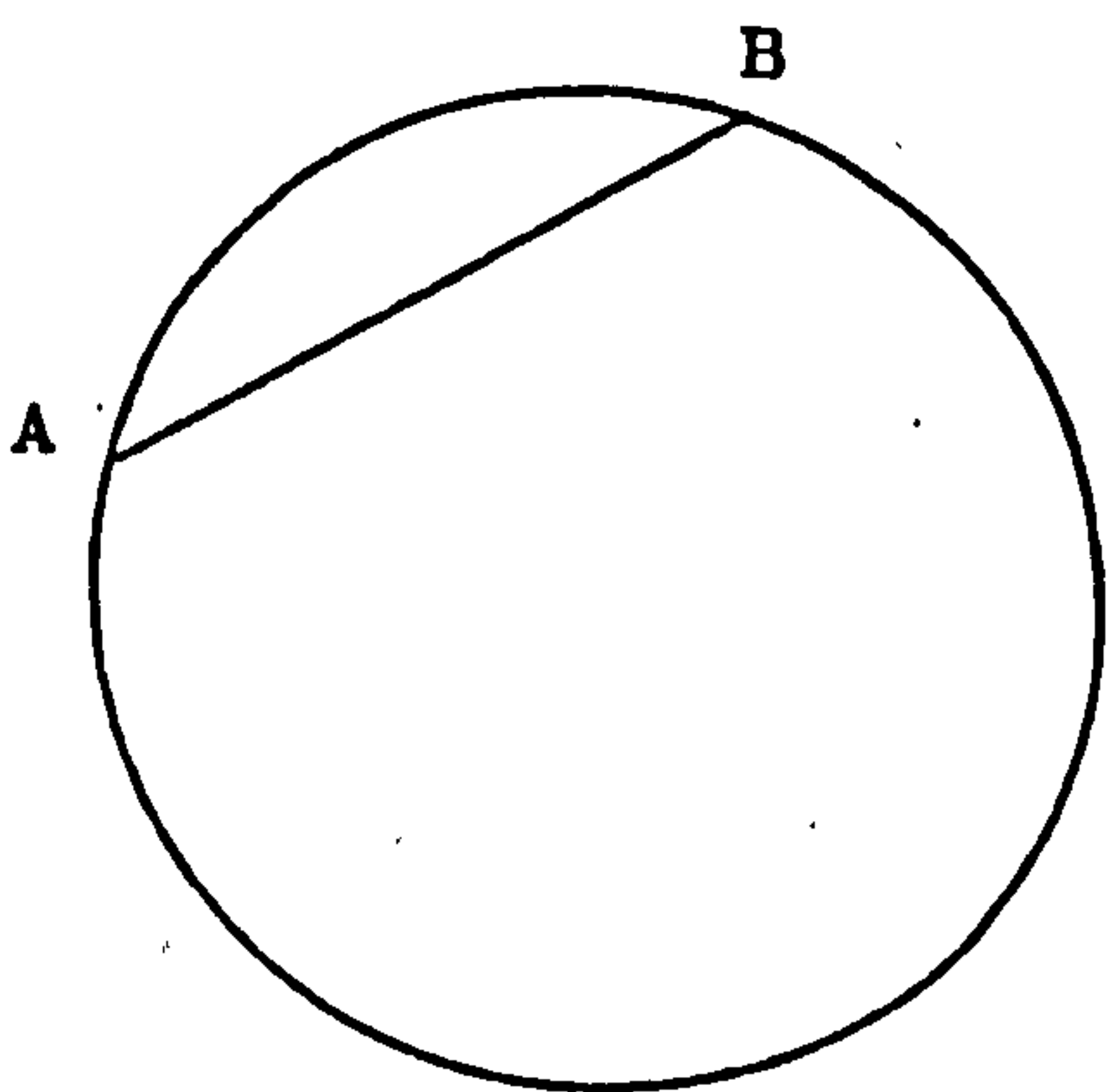

FIGURE 7

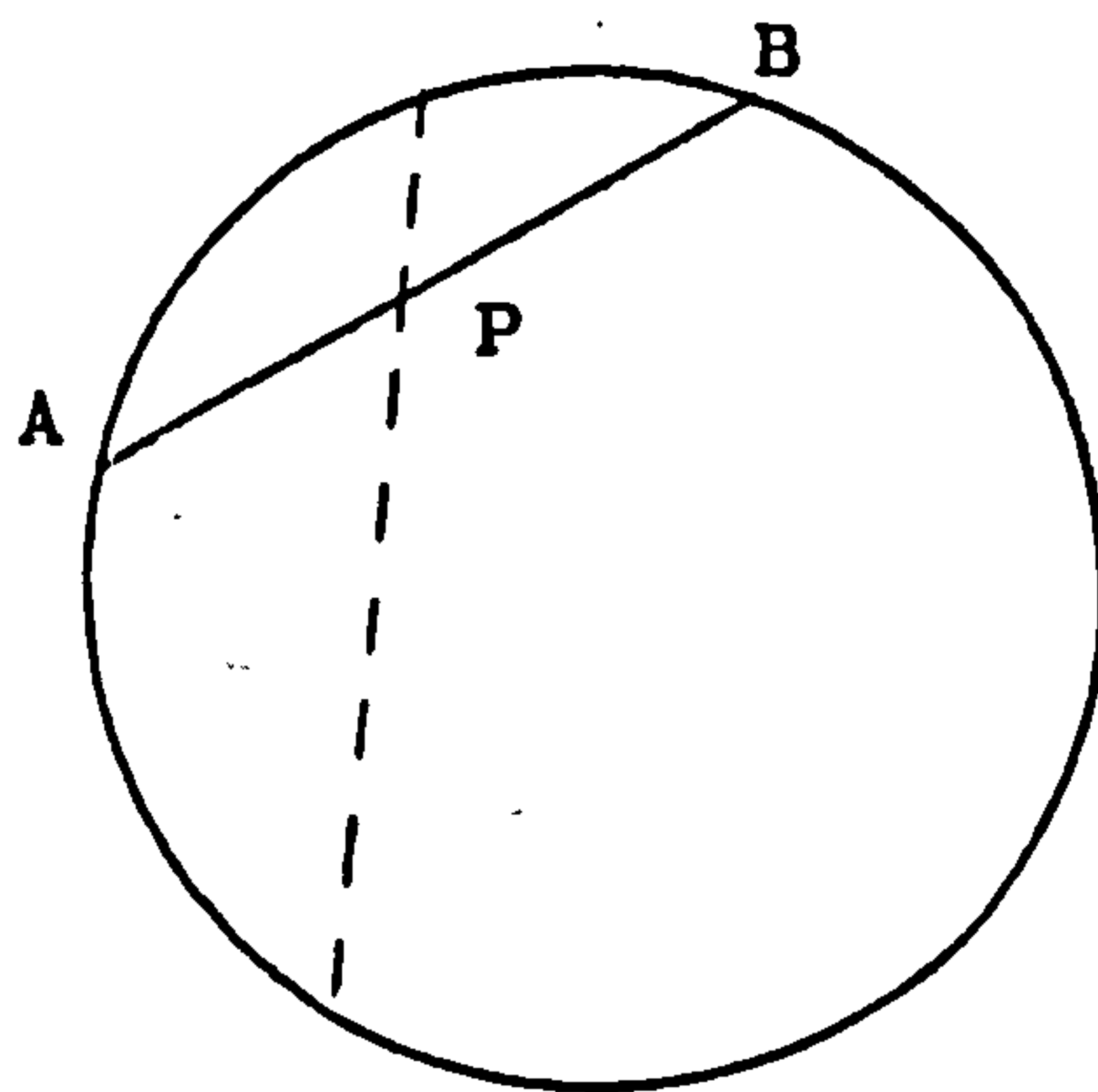

FIGURE 8

The students were then asked if this new chord is always longer than the chord 'AB'. Many of the students tried to prove that the chord is longer by construction: using 'similar triangles'. A typical construction of the type which they presented is shown in Figure 9. Unfortunately the pursuit of this line of attack does not enable the students to obtain a valid proof by conventional geometrical methods.

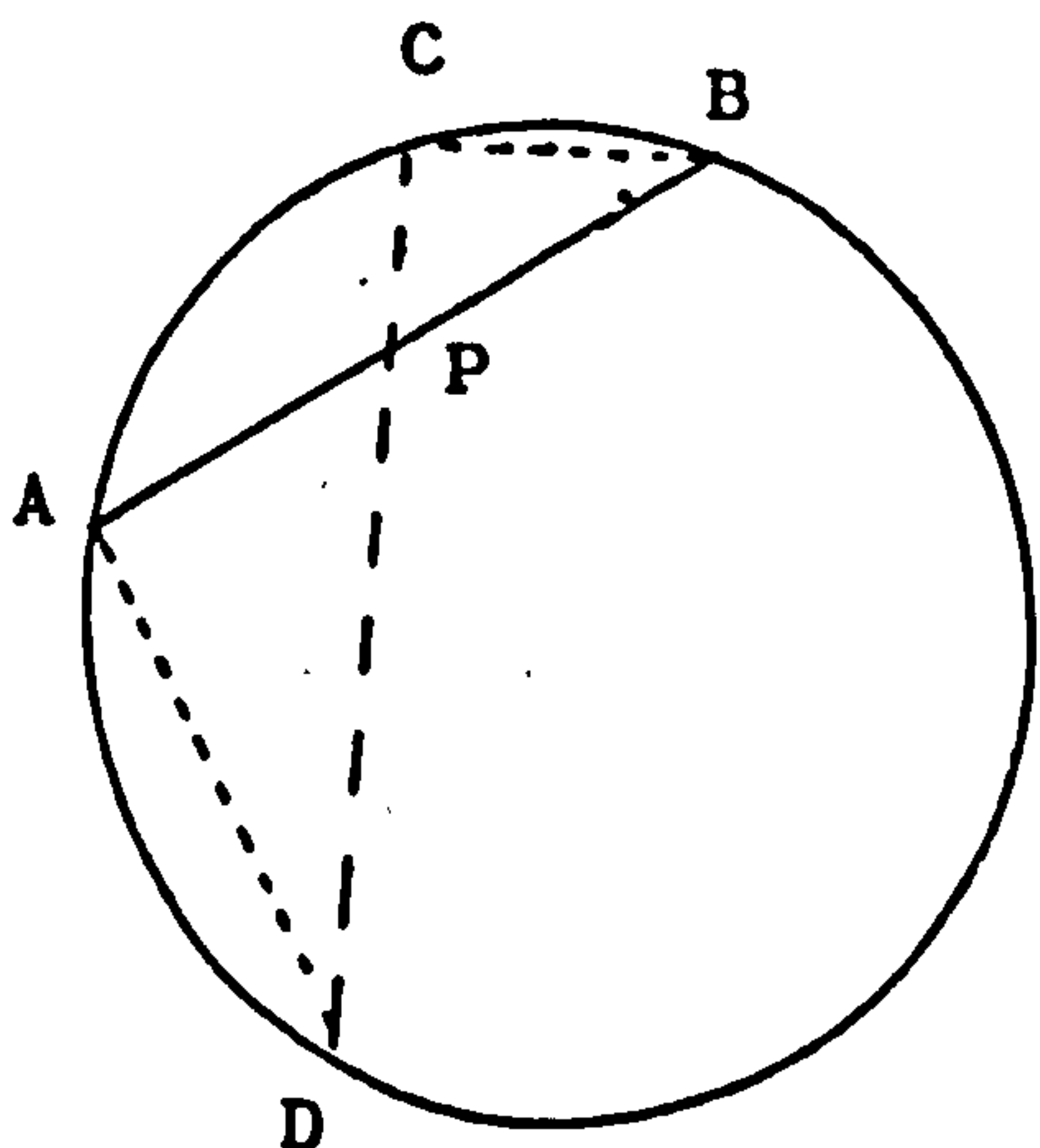

FIGURE 9

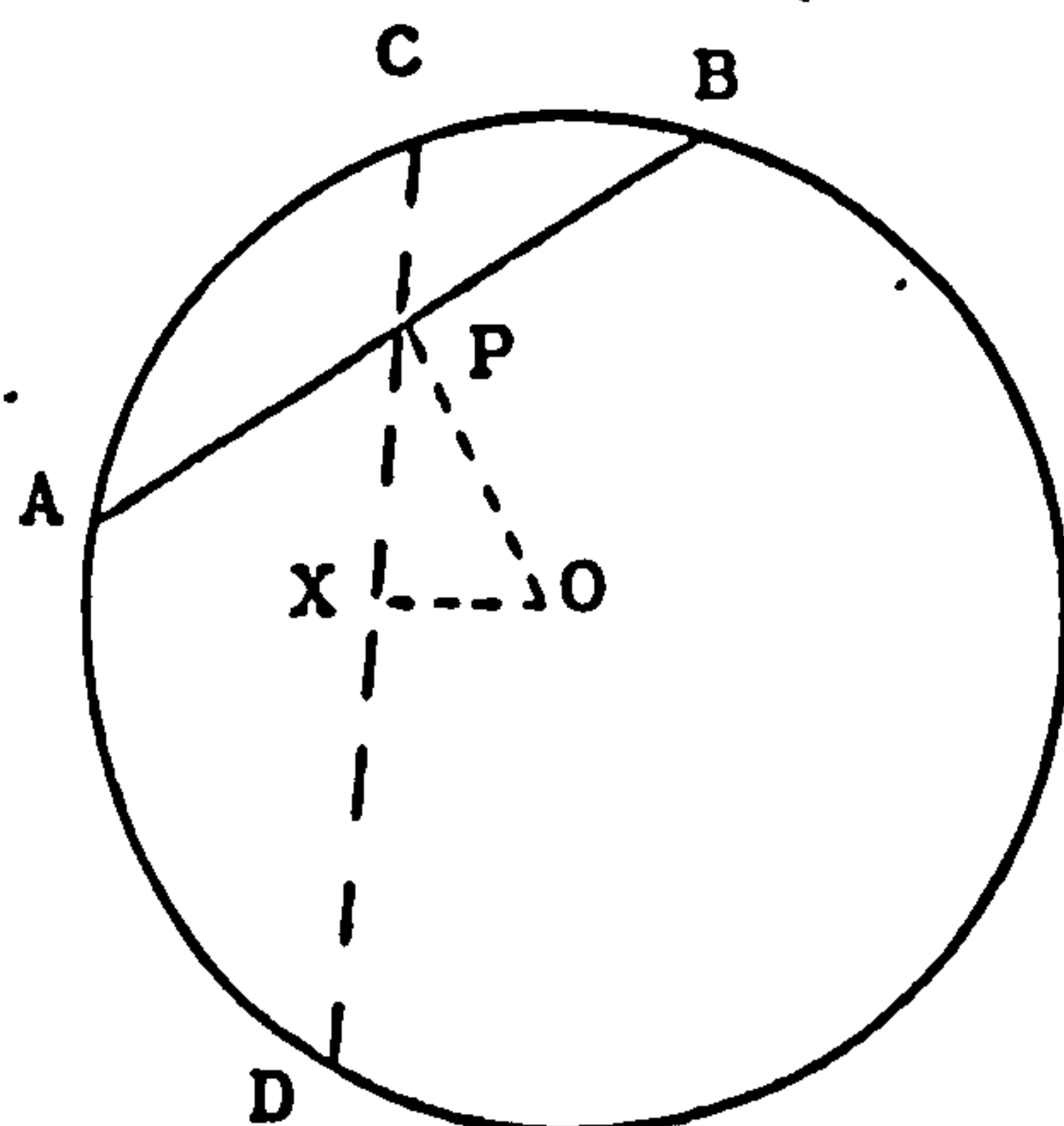

FIGURE 10

However, if the approach which will now be explained is adopted (i.e. getting the students to ask themselves questions about the problem) then such confusion and errors can be avoided. Any errors which do occur can then be dealt with more expediently (in terms of enhancing the student's learning) by the teacher using the following strategy. First, the teacher should tell the learner to carefully ask himself the question: 'Under what conditions is it possible for CD to be longer than AB?'. The student should be encouraged to experiment, and then he will learn for himself that the chord line which is nearest the centre of the circle is always the longest.

Hence, to prove the result 'all' that the learner has to do is to demonstrate that CD is nearer to the centre of the circle than is the original (bisected) chord AB. Recognition of this fact immediately suggests that the centre of the circle (call it "O") should be identified, and perpendiculars be drawn from O to each of the two chords. Since all chords are bisected by perpendiculars dropped onto them from the centre, the perpendicular drawn from O to AB actually meets AB at the very point at which AB and CD intersect. It is this fortunate circumstance which enables the problem to be solved almost at once - because the two perpendiculars - OP and OX of figure 10 - actually form a right angled triangle OXP. Since OP is the hypoteneuse of triangle OXP, and since the hypoteneuse of a right-angled triangle is longer than either of the other two sides, $PO > OX$. Hence, chord AB is further away from the centre (and, consequently, shorter in length) than chord CD.

The unreflective teacher would not have identified these factors, and hence not helped the learner achieve these valuable insights concerning the properties of chords. However, the reflective teacher would have identified the learner's errors and then used these to provide the insights described above. There are several other aspects which the reflective teacher could exploit, but it is not necessary to demonstrate these here. What needs to be noted is that, if the student can be shown how to ask intelligent questions, the appropriate "construction lines" (OP and OX) almost suggest themselves.

EF PREVENTION

There are some occasions when it may be desirable for the teacher to prevent certain EFs occurring in the learning context. This strategy is, of course, not the same thing as 'errorless learning', which was discussed in the previous chapter. What are referred to here are those learning situations where there is a need, say on the grounds of safety, to ensure that the learner does not make particular errors. For example, it is essential that

students do not make any errors when undertaking practical experiments with radio-active sources (because of the health risk involved). The prevention of errors in such contexts is, therefore a priority objective for the teacher. Unfortunately, the author's observations have revealed that many teachers do not have any really adequate procedures for EF avoidance in this type of situation. Hence, it is convenient at this point in the investigation to examine certain promising-looking strategies of EF prevention.

Initially, it must be clearly established by the individual teacher exactly what EFs need to be prevented in a given learning context. This task is not so obvious as it first appears, for as this investigation has already revealed, it is never possible to assess all the possible effects that a given EF might have. Among other things the teacher must be aware of the antecedents of the particular EF which is to be avoided. It has also been mentioned that misinterpretation is a major EFP (Error Factor Producer), and so the teacher should also take this into account in formulating schemes for EF prevention. Lee (op.cit.) believes that, in language learning, certain errors must be avoided because they tend to lodge in the learner's mind and cause considerable problems, which are difficult for the teacher to remove. Therefore, the teacher should also take account of this type of factor when analysing the learning situation in terms of undertaking EF avoidance measures.

Having established the particular EFs which are to be prevented, and determined the reasons for their prevention, the teacher can then undertake various strategies for EF avoidance. However, the author's experience is that the teacher is not always in a position of being able to exercise adequate (let alone complete) control over learner's EFs. For instance, poor teaching facilities, disruptions, and bad classroom design often mean that extrinsic factors occur which over-ride his preventive measures. Finally, the teacher should not exclude himself as being a potential source of EFs.

STRATEGIES FOR EF PREVENTION

Students often learn by 'example' (or imitation) and so the teacher must set a good example when dealing with situations where EFs are to be avoided. There is little point in the teacher instructing his students about the need to follow certain procedures in order to prevent EFs, if he does not follow these himself. Care must also be taken to avoid arousing and stimulating the learner's interest in a particular EF or hazard-such that he desires to investigate it out of curiosity. A strategy, which has been found

helpful for EF prevention, is that specifically 'telling' the student about the undesirable EF (and its consequences) makes him feel more responsible. As explained it is often ignorance which creates EFs. Thus, by removing this ignorance the teacher can prevent the EF from arising. For instance, if the student did not realise that an electrical 'capacitor' can build up charge (even when a circuit is switched off) he could receive a dangerous electric shock due to ignorance rather than an actual misunderstanding. In other words, it is not always adequate for the teacher to assume that by informing his students of the general need to exercise caution in handling 'capacitors', he has thus ruled out any further EFs in this context. (The use of anecdotal evidence concerning the harmful results of certain EFs, coupled with instructions on EF avoidance, has been found to be quite successful.)

A most useful and successful technique for the prevention of EFs in the learning context is the use of algorithms. Lewis (1965) has investigated a wide range of contexts in which algorithms can be used to prevent particular mistakes. Algorithms used for this purpose may take the forms of 'branching trees' or 'list structures' and can be presented in a variety of ways. For example, the student could be given an algorithm in the form of a 'handout' or 'over-head projector' display while his learning is taking place. Alternatively, the teacher could assist his students in devising their own algorithms (after first explaining to them the necessary objectives and so on). The type of algorithm referred to here is what Lewis (op.cit.) calls 'ordinary language algorithms', but it may be of value in special cases for the teacher to employ 'symbolic' and 'numerical algorithms' (such as are used in mathematical and computing contexts). A particularly important property of the algorithm in the context of EF prevention is that it asks the student one question at a time, thus avoiding complexity and confusion which could create further EFs.

In the following situation algorithms were actually used by Harris and R. Lewis (1978) to overcome certain errors which would seriously effect students' progress in studying 'physical optics'. The main problem which the scheme shown in Figure 11 is designed to eliminate, is that of complexity and associated inaccuracy in determining wave amplitudes, leading to a complete breakdown in problem solving and an accumulation of errors. Hence, the accuracy of computation, which would otherwise prove to be a serious limitation in the context of 'physical optics', is maintained by the use of this algorithm, and the build up of associated errors is also avoided in the same process. (See also algorithm in Chapter 4). Perhaps such preventive measures could be devised by specialists and presented to the teacher piecemeal. Moreover, there could be a 'bank' of algorithms stored

FLOW CHART TO COMPUTE 'ACCURATE' DISTANCE
IN THE CALCULATION OF WAVE AMPLITUDES

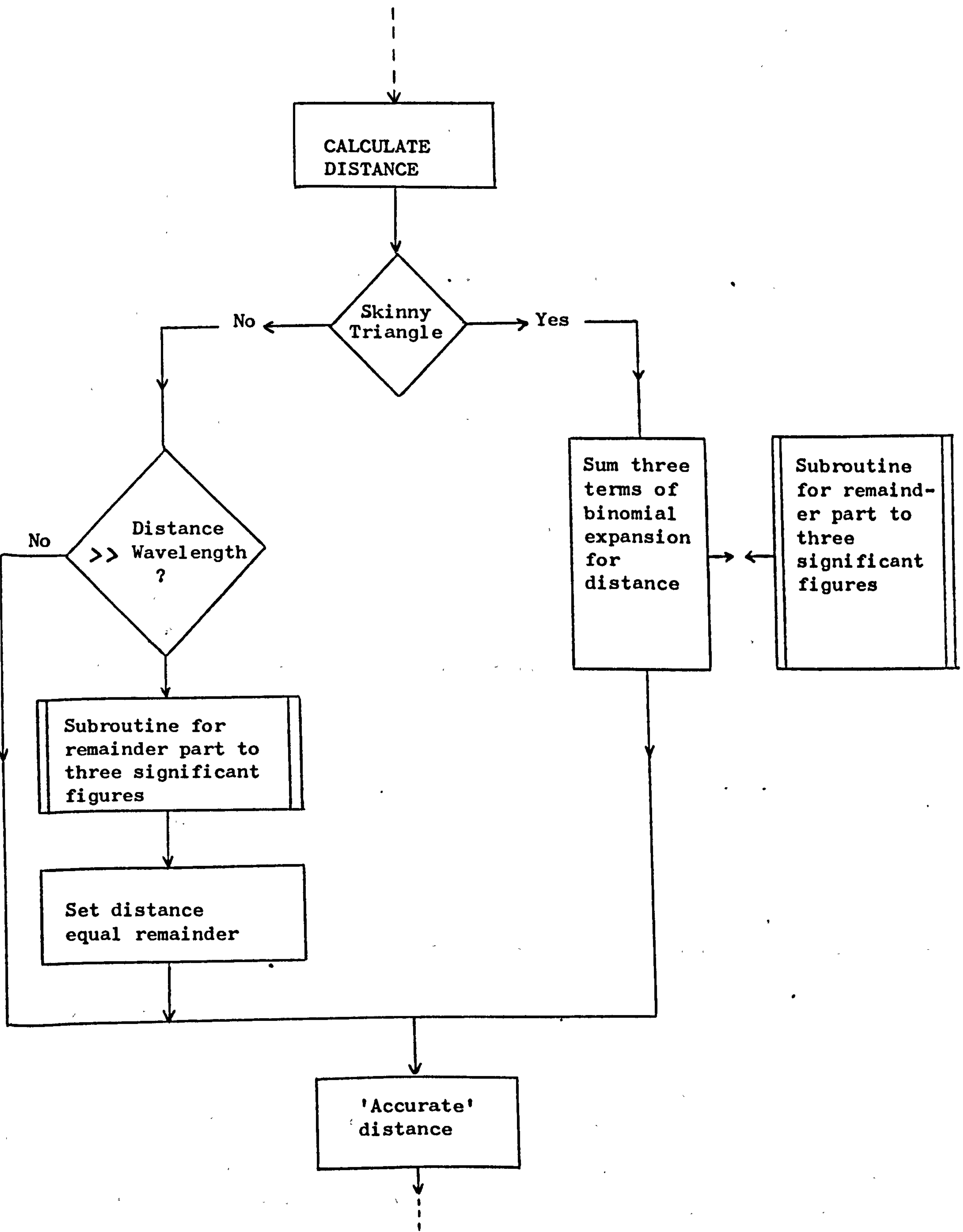

FIGURE 11

at 'resource centres' which the teacher could call upon as the need arose.

On the grounds of expediency it may be advisable for the teacher to employ several of the measures which have been advocated to prevent certain EFs, rather than rely solely upon one strategy. The problem in this respect is the accurate prediction of those EFs which could have serious or dangerous consequences in the learning context. (More will be said later concerning techniques for prediction in the classroom). However, as Olsson (op.cit.) points out, teachers should adopt a balanced view regarding the errors of their students. Otherwise, due to rigidity and resulting student anxiety, more errors could arise and this would seriously inhibit further progress and learning.

Perhaps the effects of under-emphasis on the part of the teacher, in relation to generating 'dangerous errors', should be more clearly pointed out to teachers. Moreover, it has been observed that errors are less likely to occur in situations where the learner is given clear and well emphasised instructions about EFs which are to be avoided (and is tested on his understanding of these) before he is allowed to proceed to a situation where any subsequent errors could result in harm or danger. Furthermore, it is evident that the teacher should deal with certain EFs at an early stage, so that they do not develop into more serious or complex ones. Hence, preventive measures must be timely if they are to be both efficient and fully effective. No strategy for EF prevention can be expected to be completely satisfactory if it is not properly employed by the teacher. Therefore, rules concerning the use of EF preventive techniques must be provided.

SOME BASIC RULES CONCERNING EFs

It will be helpful to consider a few basic rules (and rules about these rules) for use in EF prevention or treatment. The uses and functions of these various rules will be illustrated with the aid of one or two practical examples in the learning context. These rules are intended to be general ones, but some suggestions will later be made concerning more specific applications. It is not the author's intention to restrict the teacher, or learner, with a vast number of complex rules. Hence, what will be presented are really simple guidelines for dealing with EFs.

The first general principle or rule is that EFs must always be confirmed and identified before the teacher takes any steps to deal with them. However, there is one possible exception to this rule. The exception is

that it may be necessary in some cases (which will be described later) for the teacher to predict EFs and take steps in advance to prevent them (or prepare the learner to face them). It is an important rule, because if the teacher tries to treat EFs before they have been clearly identified he may not be treating the appropriate EF, and he could also generate further EFs as a result of this action. Once an EF has been correctly diagnosed the teacher must decide if he is going to deal with it. The means of arriving at this decision will be discussed later, and for the moment it will be assumed that he treats all EFs (using the various strategies already presented).

When teaching discriminations, Gilbert (op.cit.) suggests that the 'hard' things are taught first. It seems that this rule could also be applied to EF rectification in many, but not all, cases. For example, if a teacher undertakes to rectify an EF concerning the applications of 'Newton's Laws of Motion' it would be better to treat any confusion about the actual laws first. This is harder than correcting the misapplications first, but once these 'Laws' are mastered then their applications will become almost self-evident to the learner. Furthermore, it would be better to concentrate on the EF concerning the actual laws first, so that the basic cause of the learner's confusion can be tracked down without the teacher discovering later that the student does not understand the laws anyway.

As mentioned earlier, there are occasions when the 'easier' EFs should be corrected first. One case in point is that concerning the correction of EFs in spelling. Cotterell (1971) recommends that basic spelling misconceptions are dealt with first and the more difficult ones later. It will be shown that this is good advice to follow in teaching this kind of basic topic, and also in cases where it is necessary to first build up the learner's confidence.

There is reason to suggest that EFs which are associated with mutual confusion should be rectified together. The rule here is that EFs which interact should be removed together, but in cases where there is any chance of other EFs being made more difficult to remove, then the rule must not be applied. An example of associated EFs which should be rectified together is provided by the following case in French language learning:

The learner hears the following word read out:

"huit"

Then he is given the list shown below and asked to underline the appropriate word.

huitre, oui, huit, none, huitaine.

However, if the learner does not correctly underline 'huit' on the above list it could be that he either misheard the word, misread it, or both. If the latter condition applies it would probably be better for the teacher to deal with the joint causes of confusion together, so that the whole aspect of written and verbal misunderstanding is dealt with in unison. In this way the learner is less likely to repeat either cause of error in future language learning.

Rules and special measures can be adopted for the prevention of EFs. There are many simple rules which the teacher can present to the learner so that certain EFs are avoided. The author has observed that measures for EF avoidance are sometimes necessary because the presence of 'major' EFs could otherwise generate a large number of minor EFs, and the correction of all these EFs would be very time consuming. Furthermore, as Olsson (op.cit.) suggests, too much error correction can adversely effect motivation and the promotion of effective learning. There are various types of EF avoidance rules which can be employed, without themselves producing further errors, as will subsequently be demonstrated. (In fact, there are many such rules in arithmetic, spelling, and so on which the teacher can profitably employ to aid his learners' avoidance of undesirable EFs). If such rules are not employed then effective learning could be inhibited, because the student would be swamped with errors and confusion.

Regarding the use of spelling rules for error avoidance, the author agrees with Cotterell (op.cit.) who feels that every teacher of English should be familiar with these rules so that they can be presented whenever the need arises. Not only do such rules cut down the learning load of the pupil with spelling difficulties, but they can also provide what she calls valuable 'hooks' for the better spellers to hang their thoughts upon. The author endorses the view of Cotterell, that to be of real use, rules must be understood and (hence) kept as simple as possible. Lee (op.cit.) concludes that in language learning, some amount of student error is desirable for learning to be realistic. Similarly, he advocates that if the teacher is too strict about errors then learners may not be so bold or adventurous in their use of language and so their progress may be restricted.

REMARKS

There appears to be a strong case for teaching to be better organised on the basis of the kinds of evidence and observations presented in this section. Lewis and Pask (op.cit.) feel that a well defined and efficient teaching procedure can be structured to overcome those EFs which impede certain learning progress. In the category of 'teachable skills' which can be treated in this manner they include arithmetic and reading. The author's own research also reinforces their view, that it is possible to obtain partial orderings of EFs in the following ways:

- (i) In terms of their frequency of occurrence.
- (ii) In terms of their most probable position of occurrence (in a given sequence of tests or trials).

After further empirical investigations in this context it is also possible that procedures can be specified to detect the presence of EFs in individual cases.

It has been suggested that the provision of rules for EF removal or prevention must be undertaken with great care. When providing learners with rules concerning EFs it may be that there must also be some form of 'stopping rule' provided, so that the learner is aware when the rules no longer apply. Scandura (op.cit.) has the opinion that rules must be carefully structured and he presents clear evidence for this (in the context of mathematics teaching). However, teachers should perhaps be advised to adopt a balanced view concerning the provision of rules for dealing with EFs, and told that they should only use them to enhance learning or prevent major underlying confusion. Otherwise, there is a danger of learning and teaching becoming rather 'rule-bound' (or valuable rules not being used at all - which is equally undesirable). Furthermore, it could be pointed out to the teacher that he should carefully assess the learner, before deciding on the use of rules for EF treatment, because some learners appear to be more willing, or able, to accept and apply rules than others. Finally, it is clear that much more information needs to be obtained about the parameters of EFs so that the teacher can be provided with a number of effective measures for treating them.

In Harlow's (op.cit.) terminology, there is a single EF which is

responsible for the production of several incorrect answers. Nevertheless, Harlow's monkeys, like humans, do not always exhibit EFs in the same order or rate. Therefore, the author has found that it is necessary to embed in the sequence of 'test problems' for EF detection and diagnosis, special problems to enable other EFs which are not currently being treated, to be detected, so that they may also be accounted for. Moreover, while it is possible, on the basis of empirical inquiries, to specify measures for detecting and removing EFs in individual cases, it may be necessary for the teacher to assume that each of the learners being taught is an 'average' student. In this way, rules relating to the treatment of EFs can be both flexible and concise.

STRATEGIES FOR EF CORRECTION

A number of strategies which the teacher (or learner) can employ for EF rectification have been outlined. However, it is now appropriate to discuss certain additional and alternative measures for rectifying EFs in various types of learning situations. For instance, a particularly important aspect of EF removal or correction is the order in which certain EFs are treated. The author's investigations suggest that, what limited remedial work is undertaken in this respect by teachers, is often carried out with little thought concerning the best order and priority for correcting learners' errors.

One method of deciding the most effective order for removing EFs has been proposed by Lewis and Pask (op.cit.). This strategy was devised for use with an adaptive teaching machine, but the basic principles can be easily applied to more general teaching environments. Their basic system can be summarised as follows:

| Error Registers | A | B | C | D | etc. |
|-------------------|---|---|---|---|------|
| Instruction Given | | | | | |
| 1st Test | — | — | ✓ | ✓ | |
| 2nd Test | ✓ | ✓ | — | ✓ | |
| 3rd Test | ✓ | — | — | ✓ | |
| 4th Test | — | — | — | ✓ | |

FIGURE 12

The table shows that, at the first test, the learner gave the sort of wrong response that could be indicative of a 'C' or 'D' type EF. On the second test, the response suggested the possibility of an 'A', 'B' or 'D' type EF. And so on. After 4 tests, the evidence is "hardening" to the effect that the primary EF is a 'D' type EF.

Since the data from the successive diagnostic 'test questions' shown in Figure 12 indicates that EF type 'D' is predominant then, in this case, a special 'remedial loop' would have to be provided to deal with EF 'D' as a priority. Following this, would be treated in order of priority, EF 'A', followed by 'B' or 'C'. However, if say the EFs 'A', 'B' and 'D' were all predominant the decision of priority would then be taken as follows:

Remove EF 'A' first if its removal will help the subsequent removal of EFs 'B' and 'D'. (Or 'B' first, and so on). In other words, the decision regarding priority is taken on the basis of which EF removal would assist the subsequent removal of other EFs. What is also of concern in this respect is the problem of negative transfer effects. This means that, if say EF 'C' was rectified first, it may impede the subsequent removal of EFs 'A', 'B' and 'D'. Thus it would be wise to rectify EF 'C' last in such a case.

SIMPLIFICATION PROCEDURES

The 'performance curve', shown in Figure 13 below, relates to the learning progress of a student in an attempt to acquire skills in handling electronics circuitry. This curve is made up from an initial steady rise A - B followed by a more rapid climb B - C. However, following this stage there is a marked plateau C - D. It is during this stage when the learner has reached a temporary impasse that most learning actually occurs. What is significant in the context of this thesis is that, provided the student is co-operating in the learning, and is not simply "taking a rest" or "not trying", the plateau C - D is really indicative of an EF. The stage E - F represents a further, and possibly different, EF in the learning process.

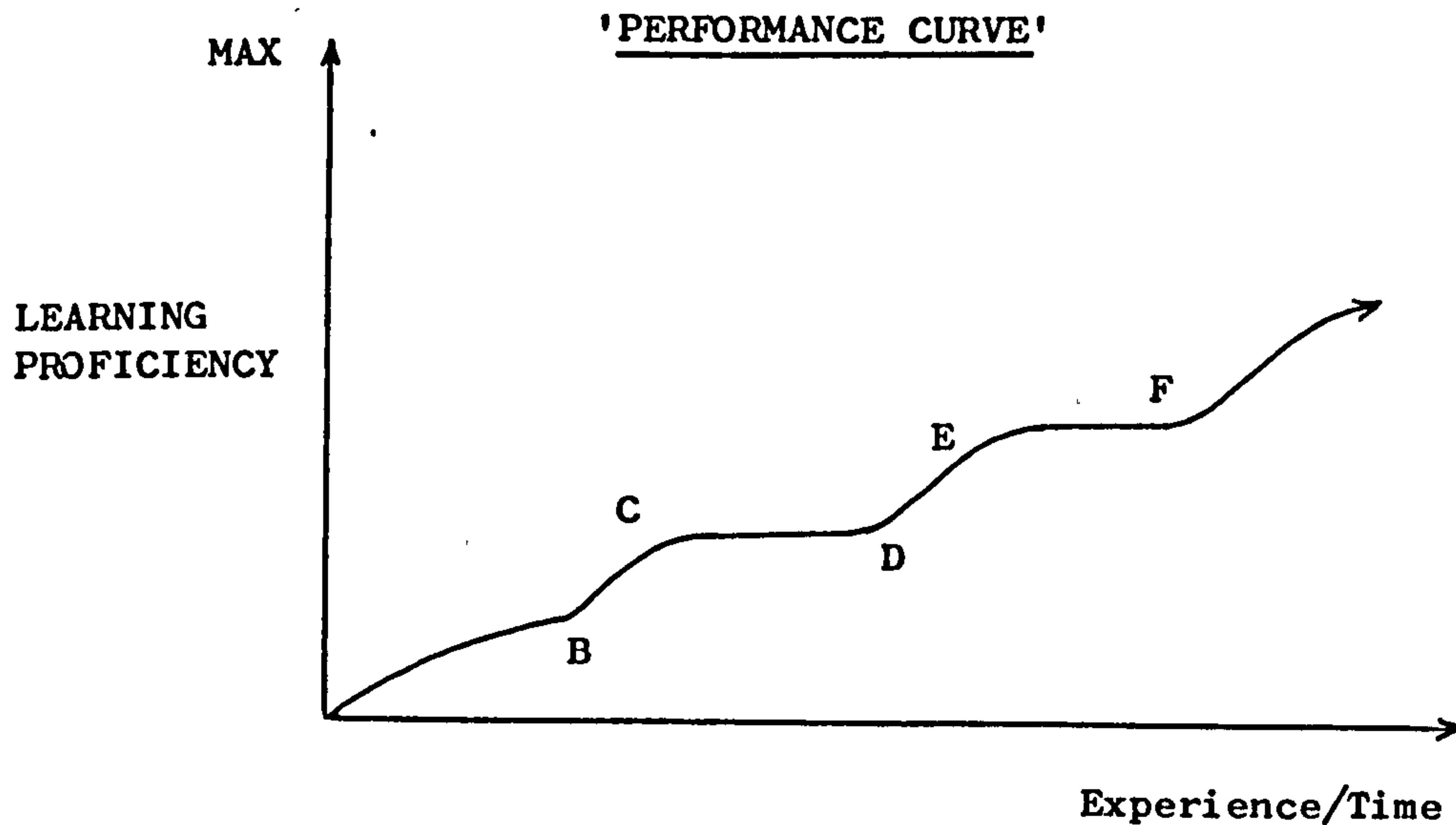

FIGURE 13

The teacher can either help the student to remove these EFs, or assist him in devising 'simplification procedures' that enable him to overcome the obstacles to his learning at these stages. If the latter strategy is adopted it could enable the student to become more autonomous when dealing with EFs and also develop his own 'insights' in this respect. Hence, for these and other reasons which will be made clear later, the author believes that there is much to be said for the employment of heuristic techniques in the learning of subjects such as physical sciences.

TYPES OF EFs

The various 'Case Studies' and examples presented so far show that certain types of EFs are often more deeply entrenched than others. Therefore, a preliminary distinction must be made between what may be called 'surface' type and 'deep rooted' type EFs. The former type are not so difficult for the teacher to discover, (as will later be demonstrated) because they are not embedded in the earlier stages of learning a subject. However, the EFs associated with fundamental misunderstanding (e.g. of the fundamental principles of 'decimal multiplication' - as shown in Case Study 1) which are of the 'deep rooted' type, are not so easy for the teacher to discover - unless he is really well informed about EFs and has diagnostic tests provided for him. It also appears that these 'deep rooted' type EFs are often of great significance in promoting higher-order levels of EFs at advanced stages of learning. Nevertheless, even the 'surface' type EFs (such as

those illustrated in Case Study 3) are sometimes quite important, since they can possibly become 'deep rooted' if not dealt with in good time.

There is some evidence, which will be examined later at a more appropriate stage, that while 'surface' type EFs may not be very severe obstacles to learning, their presence can be disruptive, and this can lead to anxiety on the part of the students - which in turn may have an adverse effect on the students' motivation. It should be noted that Harlow (op.cit.) feels that anxiety, lack of concentration and poor motivation are all EFP effects. Hence, the teacher must not always dismiss minor types of EFs as being insignificant, because they could lead to other types of EFs being promoted which have more significant and inhibiting effects on learning. Similarly, the rectification of minor EFs can, in certain circumstances, be employed to clear up a range of potentially more significant EFs (as was shown in Case Study 4). It is clear that the teacher who is unaware of this potential is missing an important opportunity to advance the learning of his students.

A further preliminary distinction must be made between what could be described as 'systematic' type and 'systemic' type EFs. The former type of EFs are those which are associated with the theory and approach to a particular topic or subject. For example, the system or approach by which 'Ohm's law' is taught could lead to the formation of some EFs or misconceptions which are a direct consequence of the system used by the teacher. These 'systematic' EFs could then extend into associated areas of the student's learning, and cause further confusion regarding electrical circuits or similar systems. However, if the teacher was better informed about this type of EF he could prevent it, by modifying his system of teaching and presenting 'Ohm's law'. Furthermore, if there were 'systematic' EFs already established, he could not only efficiently remove these but he could also extend the effects of their removal to give the learner a better understanding of all associated electrical circuit theory.

The 'systemic' type of EFs are those which influence the whole basis of understanding a topic. These are really an amalgam of several inter-related EFs which can extend throughout the learning of a particular topic or subject. For instance, certain forms of spelling or reading errors and difficulties can be associated with this type of EF. For example, according to Cotterell (op.cit.) the spelling of 'station' as 'stashun' shows, per se, that '-tion' is not known as a spelling unit. Thus, every word containing that ending is likely to be misunderstood and misspelt. Nevertheless, once this EF has been rectified the whole range of words containing that

particular ending will then be properly understood and correctly spelt. This desirable effect can be achieved, as will be shown, without the teacher actually having to rectify every individual misspelt word of this type. Perhaps an even more promising outcome is the possibility that, since learners have been observed to be frequently alike in their EFs, then the teacher could simultaneously assist all learners affected by the same particular group of 'systemic' type EFs.

The various types of EFs which were previously described, have been introduced at this juncture for didactic purposes. However, they can serve a further function in this exploratory stage of the investigation by providing some initial clues concerning the possible origins of EFs - which it is most important to discover. All the different types of EFs which have been discussed here are in addition to the four basic types of EFs identified by Harlow (op.cit.) which were described in detail in the preceding chapter. Moreover, these various types are, in general, more in keeping with what the classroom teacher is likely to encounter than those proposed by Harlow.

FURTHER ORIGINS OF EFs

It appears that certain distinctions can profitably be made between different types of EFs in terms of their origins. One such distinction (i.e. between 'deep rooted' and 'surface' type EFs) has already been pointed out. In this case the latter type of EFs may, for example, have their origin in some minor communication flaw (following the initial learning of a topic) or arise out of the learner's desire to solve problems too quickly and before he understands them properly. However, the author has noted that 'deep rooted' type EFs are more likely to occur as the result of basic confusion originating at fundamental or preliminary stages of learning a topic. This basic misunderstanding then becomes even more deeply entrenched as study of the subject or topic advances - thus making it difficult for the teacher to determine exactly what is basically promoting the learners' errors (as was illustrated in the case of Paul described in Case Study 2). Quite frequently, 'deep rooted' type EFs are already established by the time the student has to apply his learning to problem solving. However, the author has observed that 'surface' type EFs may actually be promoted by badly designed problems.

Some EFs have been found to arise as a result of the teacher being unaware of the dangers of giving too loose a notion of a concept or topic. A simple illustration of this is provided by the following example, which the author observed:

A student was told that the electrical resistance of a piece of metallic material would double if its length was doubled. He made the error of assuming that the same would also apply if the thickness of the material was similarly doubled. In fact its resistance would not increase but decrease!

The teacher in this case had not pointed out to this student the specific picture, concerning change in electrical resistance and change in physical dimensions of a material. In giving this somewhat loose view the teacher had unwittingly created an EF - which could possibly have impeded this learner's later understanding of 'specific resistivity' and all its applications. This is yet another situation in which the teacher must clearly be encouraged to make an overt acknowledgement of the effects of EFs and, therefore, also take steps to avoid promoting them.

The author has also observed that misunderstandings can originate from the teacher giving the student too narrow an understanding of a concept. In this case, the student described in the previous example, may have concluded that electrical resistance only changes with a change in length or thickness of material. He would thus be confused when he observed that changes in temperature and so on also caused changes in electrical resistance. Thus, the teacher should have explained all the factors which can cause a change in electrical resistance (or point out that changes in length and thickness are not the only factors which can cause a resistance change). Nevertheless, it has been noted that misunderstandings such as those previously illustrated, while attributable to the teacher in both these cases, are often the product of students not paying proper attention.

An attempt will later be made to discover other possible conditions and situations which could give rise to EFs. However, it is first convenient to try to 'synthesise' EFs so that it becomes clear when they are created, as against merely being enhanced by the teacher or learner in some way. For instance the author has found that certain EFs stem from a common core or origin and so it may be useful to consider the possibility of there being a kind of EF 'nucleus' in different subjects or topics. Since learners could respond to the effects of this nucleus in different ways, it would therefore give the teacher the impression that there are more (or different) EFs than is the actual case. This condition could also explain why Rabbit and Rogers (op.cit.) reported that pairs and groups of errors were observed more frequently than they would be if it was only a question of chance.

This is because the same basic nucleus could promote EFs which were different, but similar - hence causing the student to make more than one error, either at the same time, or under the same kind of conditions.

INITIAL HYPOTHESES CONCERNING THE NATURE OF EFs

There are grounds for saying that the only definite EFs having a significant role in teaching are those which can be put into one or more of the following categories:

- (i) EFs which significantly obstruct further learning in a given topic or subject.
- (ii) EFs which lead to confusion such that other EFs are either produced or have their effects amplified.
- (iii) EFs which generate whole 'classes' of errors.
- (iv) EFs which, when removed, result in the whole range of misunderstandings being removed in the same process.
- (v) EFs which have an effect of increasing a learner's anxiety with the result that the learner's motivation is considerably reduced. (NB. After their rectification this can lead to a great improvement in motivation).

These are really all different aspects of the nature of EFs, and so this list will be added to later, when more is known about their nature. This list also gives some indication of those aspects of the nature of EFs which are of particular interest in this investigation. Perhaps it should be emphasised that the particular forms of EFs which are of special interest here, are those associated with reasoning, problem solving, concept formation and its application. The teacher who is well informed about the effects of EFs has still to decide what it is that his learners

need help concerning their EFs for, and with which of these cases he can provide the best treatment to satisfy their individual needs. Hence, a clear picture of the nature of EFs must be provided for the teacher so that he can structure his teaching accordingly.

Concerning the general nature of EFs it appears that they exist at different levels as well as being of different types. Not only can they do this, but they may take on different forms with different learners or in different subjects. It also seems likely that some EFs may interact in such a way that they modify each other. Perhaps this is because some EFs are made up from a number of 'sub-EFs', and so even more sophisticated EFs could be formed from a large network of interacting 'sub-EFs'.

FORMS OF EFs

This initial examination of EFs would be incomplete without certain postulations being presented concerning possible basic forms of EFs in the classroom context. As has been described, there are various types of EFs which can be identified in terms of their origins. However, because of their complex nature it has been observed that EFs can also take on different 'forms' according to certain variables. It will later be demonstrated that these different forms can be initiated by variations in subject matter, different teaching styles, and so on. Hence, it is important that this aspect of the nature of EFs is subjected to special investigation, so that there can be a full account given with the object of improving methodology.

Different forms of EFs can sometimes result from the effects of 'system separation' in learning or problem solving. In other words, an EF can display different properties due to a learner undertaking (either conscious or unconscious) 'system separation'. For example, a student who was studying 'electrolysis' in a physics lesson was eventually found to be treating the topic in the context of chemistry, rather than physics. As a result, an EF (concerning a misconception about the flow of charge in electrolysis), which had arisen in the physics context, took on a different form than was expected, because this student was viewing electrolysis, unconsciously, in terms of chemistry. Therefore, the underlying EF (which was actually found later to be due to a basic misconception concerning electrochemistry) appeared to be a form of confusion regarding the student's understanding of the physics of electrode polarity. Hence, because of this 'system separation' it was not until this student had been questioned that the real form of the basic EF was discovered.

Studies in 'second language' learning have shown that the same basic misunderstanding in the 'primary language' can take on a different form in the 'second language'. For example, a student's confusion about the use of the 'present perfect' tense and the 'preterit' in English would have a different form if the student was also studying German. This could lead to a misconception regarding the actual cause of the student's difficulties in this respect. In 'second language' learning the situation is further complicated because most of the 'first language' is learned unconsciously, and so the basis of any confusion with respect to this is less distinct.

The form which an EF takes can also vary if it is transferred from a practical context to a theoretical one, and vice versa. Thus, a student of physics, who has some basic misunderstanding about the theoretical concept of 'optical wave diffraction', could also be seen, for example, to set up an inappropriate practical experiment to measure the wavelength of a light source. It could be concluded by the unreflective teacher, therefore, that two different EFs were in operation. However, these are actually two different 'forms' of the same basic misunderstanding. Only by careful EF analysis, as will later be demonstrated, could this type of situation be identified and subsequently corrected by the teacher. Incorrect diagnosis would not only result in the underlying EF remaining unrectified, but it is also possible that the teacher could carry out irrelevant error treatment which actually promoted further misunderstanding.

It has been observed that language errors due to basic etymological confusion can take on a great variety of forms. Moreover, failure on the part of the teacher to appreciate the prime source of confusion could lead to a whole spectrum of incorrect decisions being made concerning the nature of the basic EF. This situation is illustrated by the following example:

In this case a student misheard the word 'acquiesce' in an English lesson and thought that the word was 'aqueous'. However, he was told the meaning of 'acquiesce' during this lesson so he therefore associated this meaning with the word which he heard. Some months later, in a physics lesson, the word 'aqueous' was encountered by the student and he was naturally confused (since its use was related to experiments using water). The physics teacher did not rectify the true

form of this EF. Similarly, when the student later used the word 'aqueous' in an essay, his English teacher thought he had merely misspelt 'acquiesce' and did not explain the meaning of 'aqueous' (this not only added to the student's confusion but leaves its basis unrectified).

The author has noted that there are many forms of EFs which are attributable, in some respect, to erroneous etymological foundations.

The 'form' of an EF can also significantly change with changes in the level of study. For example, errors and confusion concerning 'logarithms' in mathematics often have a far different form in the context of 'advanced level' mathematics, than they do at more elementary levels. Moreover, it has been observed that some teachers and the authors of 'text books' consider that because a student has reached a more advanced stage in his studies, he will, therefore, not become confused by different forms of the same basic misunderstanding of logarithms as he would in the elementary stages of studying this topic. Hence, they either fail to treat the learner's confusion about logarithms which is persisting from his earlier studies, or assume, because of changes in the form of confusion, that different factors are responsible for the student's difficulties and thus they present inappropriate corrective measures.

ERRORS IN REASONING

It has been noted by the author that fundamental misunderstandings in reasoning by learners can promote considerable errors and confusion. Moreover, since various forms of reasoning are widely employed by learners, then any EFs in this context could have widespread consequences. Hence, an examination will subsequently be made of both verbal and non-verbal reasoning by learners. Furthermore, confusion due to a reasoning error may also be transferred from elementary stages through to advanced stages of learning if it is not rectified. Therefore, it is considered that the prediction and subsequent prevention or corrective treatment of errors in reasoning is a most important task for the teacher.

The main concern in this context is the prediction or diagnosis of the EFs which are responsible for reasoning errors - followed by the prevention or removal of the underlying causes of these errors. Since reasoning is

essentially a process of thinking involving inference, then it should be possible for the teacher to anticipate the learner's errors, if certain factors about the learner and the topic are known. The first step in this respect is to predict the form or type of reasoning which the learner might adopt. This is not as difficult as it first appears, because it has been observed that learners tend to adopt definite patterns of reasoning. Having established this pattern the teacher might then go on to deduce that perhaps the learner will use an inappropriate class of reasoning (or employ an appropriate form of reasoning erroneously). For instance, the teacher may anticipate that a learner who is confronted with the following problem would employ an inappropriate class of reasoning:

Reasoning Problem (for pupils aged about 12 years)
(given only in general terms for simplicity).

All metallic substances are good electrical conductors. Silica is not a metal. Is silica a good electrical conductor?

The teacher could anticipate that the learner might adopt a form of conditional reasoning to 'solve' this problem, as follows:

All a's are b; since 'x' is not in 'a' then 'x' is not a 'b'.

To prevent this erroneous reasoning the teacher could modify the problem as follows:

Without exception all substances which are good electrical conductors are metals. Silica is a non metallic substance. Is silica therefore a good electrical conductor?

By modifying the problem in this way the teacher will help to induce the learner to employ 'class reasoning' rather than 'conditional reasoning' because he has marked the different 'classes' in the problem. If this and similar reasoning errors are not prevented they could also result in the learner making dangerous mistakes when dealing with practical electric circuits.

The author has observed that errors in reasoning can be discovered by the use of 'reasoning tests'. This may take the form of special data from which the student is required to draw conclusions. Alternatively, a 'reasoning test' could involve the student in checking the validity of conclusions which have already been drawn. However, in either case the tests would provide the teacher with valuable evidence concerning his student's modes of reasoning and any associated misunderstandings. In a different respect it was pointed out that Fischer (op.cit.) has identified a number of 'fallacies' which have been perpetrated by historians. These include the use of erroneous analogies between past and present attitudes or values. However, in the context of learning, EFs which arise from the learner 'reasoning by false analogy' require special treatment, as will subsequently be explained. Nevertheless, if the teacher prepares the learner, or the learning situation, accordingly, then many errors in reasoning can either be prevented, or removed without too much difficulty. Unfortunately, if these measures are not taken in good time then the student could have his later progress seriously inhibited. Errors in reasoning and judgement will be investigated further, and in greater detail, later in this thesis.

EF GENERATORS

As reported by Levine and Schrier (op.cit.), certain classes of stimuli can act as 'error factor producers' (EFPs). Three of their four classes of EFPs are of particular interest in the context of this enquiry. The first of these EFPs they classed as 'changing cues', in the external environment. In the classroom situation many changing cues may be experienced by the learner. For instance, different teachers may teach them the same subject and bring all their own idiosyncrasies into the learning situation. This disturbing situation could then stimulate latent EFs into actively obstructing the learner's progress. Perhaps, if teachers are made aware of this possibility, certain constraints or remedial measures could be adopted to avoid exacerbating the situation.

The second class of EF promoting stimuli, which should be accounted for by the teacher, actually result from the behaviour of the learner himself.

Although Levine and Schrier were working with monkeys in their investigations, it appears that human behaviour can also promote EFs. For example, a learner may like to act and work in arithmetic in a particular manner, such that he does not account for all his working by writing it down. As a result, he may miss out certain important operations, and so, when he obtains an incorrect answer, both he and his teacher find it hard to discover the source of his errors. Therefore, unless he can be made to act or behave in such a way that he writes down all his 'working out', the teacher would find it difficult to pinpoint the learner's underlying confusion (or indicate the actual source of these errors to the learner). This is a situation which the author observed many times and so, in anticipation, students are always asked to write down all their working - for their benefit as well as the teacher's (also because this is quite often the main source of 'random errors' or difficulties). However, it has been noticed that such situations seem to occur less frequently in the case of slow, methodical students.

The presence of rewards and non-rewards in preceding learning is the third class of EF producing stimuli identified by Levine and Schrier, which it is necessary to take account of here. In the classroom context this class of stimuli could result from the teacher forgetting to praise or confirm the learner's correct work, preceding the current learning task. As a consequence, the learner may become confused as to the validity or merit of his earlier responses, and thus make errors in his current work. For example, a physics student became used to his teacher informing him when he made mistakes in his work, but not communicating with him when he made no errors. However, on one occasion the teacher did not specifically refer to this student's errors concerning the diffraction of light, but to the errors of the students in general. Hence, when this student then studied the diffraction of x-rays, less than a month later, he maintained the erroneous concept which originated from the earlier work on light. As a consequence of this situation, he became deeply confused about the diffraction of x-rays (this in turn was reflected back to his earlier work on the diffraction of light and added to his confusion). The outcome of this was the generation of a considerable number of errors and misunderstandings concerning all aspects of diffraction. Nevertheless, due to the effects of a greater time delay and memory limitations, subsequent learning may not have been so severely handicapped by this (i.e. if the learning of x-ray diffraction had not followed after a short break).

It has been found that the generation of EFs can sometimes be closely linked with learner fatigue (perhaps also teacher fatigue). In a number of separate incidences, the author has observed a significant increase in the

number of errors and the level of misunderstanding during the teaching of 'evening classes'. These were classes which students had attended after spending the working day at their full-time occupations. None of the students in these cases were lacking in motivation, because they all had very good reasons for attending these courses. Perhaps more research should be undertaken to discover the full significance of learner fatigue, and associated phenomena, with respect to the generation of EFs.

It has been reported that 'time pressure' on a student can be an EFP. However, the author has found that it may also have the effect of what might be described as an 'error catalyst'. This is because its presence can stimulate or promote other EFs which would otherwise lie dormant. Hence, the presence of an 'error catalyst' can create considerable learning difficulties. Nevertheless, the teacher could perhaps employ 'error catalysts' to reveal the full extent of a learner's confusion at an early stage. At the moment, little is known about the nature and forms of 'error catalysts'. The author suggests that they are special hybrid forms of EFPs and are themselves actual EFs.

Levine and Schrier (op.cit.) discovered that a large number of EFPs were always associated with a difficult problem or task. Thus, the teacher could 'control' task difficulties in this respect if he had a good understanding of EF theory. Moreover, if he wished to increase problem difficulty he could introduce further EFPs into the problem situation. However, the author considers this would have to be carefully controlled. The same exercise could also be carried out to give the student experience of working in confusing situations. Nevertheless, it is not always the case, as was reported earlier, that the more difficult the task or problem, the more EFPs are present. Therefore, the teacher should not assume that the learner will face successively more confusion when confronted by problems of increasing difficulty.

CHANGES IN EFs

In order to complete this initial examination of EFs it is necessary to examine possible changes in their nature. This is because the author has detected what could be described as a form of 'EF metamorphosis' on a number of occasions. Unlike a change in the 'form' of an EF, as examined earlier, this is generally a very gradual change, and the final form is sometimes very different from the initial form.

To illustrate this theory concerning 'EF metamorphosis' the following example will be briefly outlined:

This case involves an 'advanced level' physics student who had certain misconceptions concerning electric current. In particular, he was confused about the distinction between the direction of 'conventional current' flow and 'electron current' flow. For some reason, his basic confusion was allowed to persist from his earlier studies unrectified.

Retrospective error analysis revealed that after some time, the student's basic misunderstanding had changed into confusion concerning electric current (in terms of the 'flow' of charge). Later still in his studies, the author found that the basic misunderstanding had changed again and developed into an erroneous conception of electric charge. Some year or so later the student's changed confusion had undergone further metamorphosis and now concerned errors and confusion about static electricity. However, it was only after undertaking a considerable amount of retrospective analysis of this student's earlier work and studies that these gradual changes in his errors and confusion were observed.

The mechanism of this process still remains to be discovered and so it is not clear if this effect can be predicted.

It appears, at the moment, that 'error metamorphosis' is a complex function involving learning time span, learning levels or stages, and some unknown cognitive process (perhaps a kind of mental 'sorting out' process). Etymological errors and confusion have also been observed to undergo this process. It could, therefore, be associated with the learning of topics where gradual stages of development or derivation are involved. The reasons why it occurs at all, are also still not clear. From a review of certain literature on language learning difficulties, the author has come to suspect that some researchers are aware of the effects of this phenomenon, but have not really attempted to analyse or examine it. Nevertheless, Nickle (op.cit.) in his studies of variables in a 'hierarchy of difficulties' in foreign language learning, refers to a general increase in the complexity of learners' misunderstandings as learning progresses to an advanced level - which he suggests is also responsible for an observed decrease in their motivation. Perhaps these learning difficulties are really the same basic ones that were present at the earlier stages of learning, and have changed with the gradual change in learning level (and in changing have become, or appear to be, more difficult and complex). This theory seems reasonable, unless we assume that certain EFs and difficulties suddenly 'appear' in the advanced stages of learning a subject, as will be discussed later.

SUMMARY

Various Case Studies and 'protocols' have been presented in this chapter and these have not only revealed a number of important facets of both the nature and treatment of EFs, but, in addition, also provided a framework for the subsequent theoretical discussions. The possible causes and origins of certain EFs have also been described and analysed. Moreover, much of what has been discussed and demonstrated in this chapter points to the need for teaching procedures to be carefully structured so that they take account of EFs. This requirement also demands the provision and design of techniques for EF prevention or avoidance, and preliminary strategies, which the teacher himself can employ, were presented. Some basic rules for EF prevention and treatment were then proposed. Furthermore, the order of priority of EF removal or rectification was also examined and various strategies for determining this order have been described.

It was suggested that EFs can, in some cases, grow or extend from what could be described as a kind of 'EF nucleus'. Some ideas were also put forward concerning the circumstances under which EFs are likely to occur (such as where too narrow an understanding of a concept is given by the teacher). A further significant observation which was reported is that some EFs seem to be able to be transferred from one topic, or subject, to another. They may even be responsible for promoting negative attitudes amongst learners to complete classes of subject matter (such as children like Paul in Case Study 2, who disliked all arithmetic because of the effects of certain EFs). It was for these and other reasons that 'simplification procedures' were then briefly examined. However, while there are vast numbers of potential EFs in the learning situation it seems that not all of them actually come to affect all learners; yet there appears to be a definite pattern of EFs, although it is not clear, as yet, why this is so. It was also pointed out that EFs are often already present in the learning situation, and sometimes only need to be triggered off by something (either the teacher or learner can do the initiating) to become active. A much more important observation though, is the probability that EFs can be controlled - if the teacher is provided with certain strategies for this purpose (as was revealed). This element of control is one of the most important facets of the nature of EFs and one that will later be examined in greater depth.

In this chapter various types and forms of EFs have been identified and preliminary suggestions made regarding their origins. Moreover, some initial

hypotheses have subsequently been proposed regarding their nature and properties. However, it was later reported that there have been various changes in their nature observed and this factor was also examined. In addition, the concept of EFPs (error factor producers) was discussed and its significance in the classroom context was assessed. All the evidence and implications presented in this exploratory examination of EFs will be taken into account in the following detailed investigations of their role in teaching.

CHAPTER 3

STRATEGIES FOR TREATING EFs AND A DETAILED PILOT EXPERIMENT

INTRODUCTION

The need for paradigms and various systematic strategies to be provided for the teacher in order for him to treat the EFs of his students, has been clearly demonstrated in the preceding sections of this thesis. From the various Case Studies and other evidence which has been provided it has also been established that, in many cases, EFs can be treated by the teacher at relatively cheap cost. However, in order to do this more generally we must first investigate and design procedures for detecting and confirming EFs (i.e. prior to identifying and classifying their type or form). Furthermore it has been observed that, what some teachers call 'mistakes' are really EFs, and so some definite means of clarifying this point must also be devised. The tractability of the various schemes that will be proposed for treating EFs will be examined in dialectic terms and subsequently assessed in a practical teaching context as part of a detailed pilot investigation. Later in the chapter this experimental data will be carefully analysed and conclusions drawn concerning the major implications of the findings.

COMMENTS ON THE DETECTION AND DIAGNOSIS OF EFs

The early detection of EFs is clearly a fundamental requirement if the teacher is to deal with them at the most suitable stage. In some cases they may make their presence obvious because of the student error and learning difficulties which they produce. However, when these 'gross effects' are observed the EFs causing them may have produced some considerable harm to learning success, or have become so deeply rooted that they are then difficult for the teacher to remove. It may also be subsequently discovered that more than one EF is acting in the same context at a particular time (perhaps in such a way that it 'masks' the presence of the others). Similarly, it has been found that it is important for the teacher to determine which, of several 'known' misunderstandings, is operating at a particular time. The provision of effective strategies for diagnosing EFs is, therefore, a prime

necessity at this stage. Unfortunately, these strategies are not an end in themselves; for the teacher still needs to be able to identify specific EFs and then have adequate schemes available to remove or correct them.

In the course of the investigations regarding the detection and diagnosis of EFs a number of teachers were questioned about the ways in which they detect the basis of their learners' errors and misunderstandings. It could be of value at this stage to briefly examine some of the answers and comments which were recorded. However, it must also be pointed out that many teachers admitted that they were not very successful in this respect (as will later be discussed). A few teachers actually said that they took no active steps, as such to discover the underlying causes of their students' confusions (because they felt it was too time consuming and complex a task). Furthermore, it was noted that none of the measures which were employed by the teachers in question really took account of EFs in the scientific way which will be advocated here. In other words, it was observed that the insights which certain teachers had, concerning the errors which their students made in attempting to learn a particular subject, were not being employed in an effective or systematic manner. While it appears that the teachers' intuition does sometimes play a useful part in the detection of EFs, there is still a need to discover why successful intuitions actually work.

It will now be helpful to briefly discuss some of the further issues which arise from Harlow's key experiment (described earlier) from the point of view of the teacher who is trying to maximise the benefits which were previously enunciated, concerning the efficient exploitation of EFs to enhance learning. Firstly, there is a possibility which must be taken into account, that a student, like a monkey, can suffer all the possible misunderstandings in a given context simultaneously. Harlow (op.cit.) considers that, in order to learn, the monkey gradually eliminates inappropriate responses. It may, therefore, also be possible for the teacher to detect and identify any simultaneously occurring mistakes by a gradual process of elimination of the possible underlying EFs.

Another important factor in this context which has been observed, is that 'partial' misunderstandings frequently occur. These cases are often quite difficult for the teacher to detect, since he may identify either that there is no misunderstanding, or that there is complete confusion. Fortunately, unlike Harlow's monkeys, the student can be questioned, and so this situation may not be so difficult to resolve in actual practice, since the parameters of the partial confusion can be determined using an appropriate elicitation technique, as will be demonstrated.

Perhaps strategies for EF diagnosis could embody some modified form of elementary 'probability theory' and techniques, as used in experimental science investigations. In other words, the teacher could make use of his intuition and experience to draw up a list, a table, or a series of 'common' EFs at particular stages and levels of learning. This could be modified from year to year to reflect changes in student background, subject matter and so on. He would then work through the list, starting with the 'most probable' EF and check these off until the presence of an actual EF is detected in a particular case. In practice this diagnosis could also be achieved by using simple test problems to identify learners' EFs or misunderstandings - such as those employed by Brown and Burton (op.cit.). Alternatively, this diagnosis could be achieved by employing 'feedback questions' in conjunction with an electronic 'feedback classroom' as described in Chapter 1. However, as was reported earlier, Olsson (op.cit.) found that learners are often very alike in their misunderstandings. Therefore this diagnostic exercise could be quite concise and viable, and would ultimately save the teacher time.

Perhaps, when analysing the errors of his students, for the purpose of detecting specific EFs, the teacher should also consider if he is in any way influencing either the occurrence or frequency of their EFs. In this way he may develop a more objective scheme for diagnosing EFs than could possibly be given to him 'piecemeal'. Similarly, he could investigate the EF distribution of his students, and compare this to those of his colleagues' students, so that he acquires a more composite picture for use in future EF diagnostic schemes. Furthermore the author has observed a definite correlation between poorly ordered and 'structured' teaching and the incidence of a large number of student EFs. Thus, by attempting to detect and assess the misunderstandings of his learners a teacher may become more aware of his own shortcomings and contributions in this respect. Finally, as Hammarberg (op.cit.) points out, the experienced teacher can also learn much about his students' difficulties from studying 'non-errors' as well as actual errors. Therefore, it is a fundamental requirement of the proposed strategies for EF detection and diagnosis that the teacher examines the entire picture of the learners' work and all his responses.

PRELIMINARY STRATEGIES FOR EF IDENTIFICATION

While it is obviously of great value for the teacher to be provided with a scheme which enables him to detect that his students are experiencing specific learning difficulties this in itself is not enough. The next step, therefore, is to provide strategies for identifying the actual underlying

causes of confusion. For example, if it can be arranged that the teacher identifies the 'root cause' of an EF (due to, say, certain 'over generalisations' during the student's earlier learning) he is then in a good position to deal with it. However, in order to identify the basis of EFs in this way the teacher must be provided with precise knowledge concerning their forms and types, so that he is clear about what he is identifying. In practice, it has been observed that many teachers can 'sense' that their students have some fundamental misunderstanding (or deep rooted problems in acquiring a skill) but are unable to identify the basis of this. As Lewis (1965) suggests:

"If we can identify the error factors that obstruct the learning of a skill, we will probably find (as Harlow did) that error factors appear in different degrees in different subjects."

The initial task is to provide some effective means of diagnosing and identifying which of several possible EFs is causing the difficulties discovered by the teacher after using the proposed scheme for EF detection. This diagnosis can be achieved using a special 'elicitation technique' either based on verbal 'question and answer' methods or on written 'test questions' (which require the student to explain his answers). Using the evidence obtained in this way the teacher could then employ what may be described as a scheme of 'symptomatic' EF identification and analysis. In other words, he would examine the 'symptoms' of the misunderstandings, revealed by 'elicitation' measures and the test questions or answers, and then identify the causes of these 'symptoms' (i.e. the underlying critical dimension of confusion or basic EF). However, in practice this means that the teacher must have some definite means of classifying EFs. Therefore, a provisional theory and scheme for EF classification will be presented for this purpose in the next section.

A further strategy, which the teacher could use to identify individual EFs, is to look for what could be termed 'homologous EFs'. These are EFs which relate to given patterns, areas, or forms of misunderstanding. For instance, if in learning arithmetic the learner makes errors which are subsequently detected as being associated with misunderstanding 'arithmetical subtraction', then these could be caused by him either using one of several known incorrect strategies, or erroneously employing the correct strategy. By looking at the form of the learner's answers, or at the pattern of his incorrect working, the teacher could then identify the basic cause of these errors (e.g. he may identify that the learner was, say, not carrying the '1' after making the previous column up by 10 during subtraction. Alternatively,

he may find that the learner has been incorrectly interpreting the rule concerning carrying the remainder in subtraction). However, by using the proposed technique the teacher can reliably identify specific underlying EFs in such cases. Nevertheless, he should still confirm this diagnosis by using special 'test questions', as will shortly be indicated.

A useful strategy which the author has devised for identifying the underlying EF in cases where there are a number of related errors detected, could be described as a 'precipitation technique'. This technique may also be used in cases where a large number of similar errors are observed in a given context (which makes it quite difficult for the teacher to identify the underlying source of confusion). The technique can be summarised as follows:

- Step (i) Group together all the errors that are revealed and confirmed by 'test questions', which are probably the result of the same underlying EF; or which appear to be produced by similar misunderstandings.
- (ii) List these common groups: 1, 2, 3 etc.
- (iii) Set further more specific 'test questions' to confirm, or reject, the presence of an individual EF for each of these groups. (indicate this presence by 'EF', as shown in the table).
- (iv) Set tests using really specific questions (see below) to 'condense' list to one basic EF.

Example:

| 'Possible' EF | 1 | 2 | 3 | 4 |
|-------------------------|----|----|----|----|
| 1st. Precipitation test | EF | EF | EF | EF |
| 2nd. Precipitation test | EF | | EF | EF |
| 3rd. Precipitation test | | | EF | EF |
| 4th. Precipitation test | | | EF | |

Thus the basic EF in this case is that associated with group 3 i.e. the other errors are derived from this.

Obviously, the more numerous and diverse the diagnostic 'test questions' the more reliable and accurate the identification obtained using this scheme. As the teacher desires, this test could form part of an 'entry test' before he commences a further stage of teaching.

The teacher could also identify the fundamental or underlying EFs by using specific 'test questions' made up from conflicting facts or statements. This technique would reveal the depth and nature of the learner's understanding, and so enable the teacher to diagnose those specific EFs which are affecting this understanding. Alternatively, the diagnostic 'test questions' could take the form of a test of ignorance - since by discovering what the student does not know, the teacher could then go on to isolate the confusion which is causing this ignorance. It has been observed that multiple choice 'objective type' diagnostic test questions can usefully be employed in cases where the teacher wishes to identify both 'group' and 'individual' misunderstandings.

SAMPLE TEST QUESTION:

"Comment on the operation of the circuits (a), (b) and (c) shown in the diagram. Give an explanation of your comments in each case".

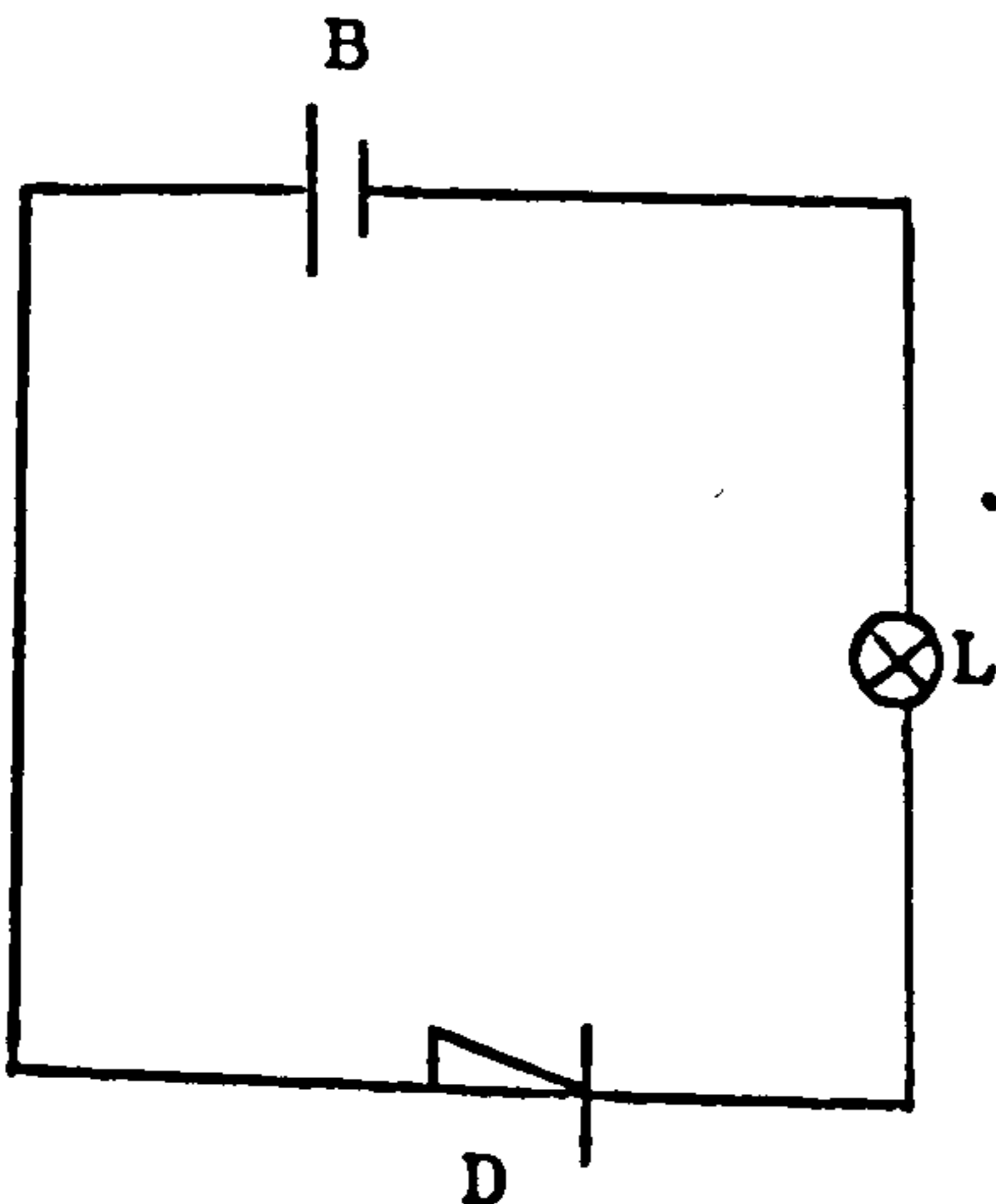

FIGURE 14 (a)

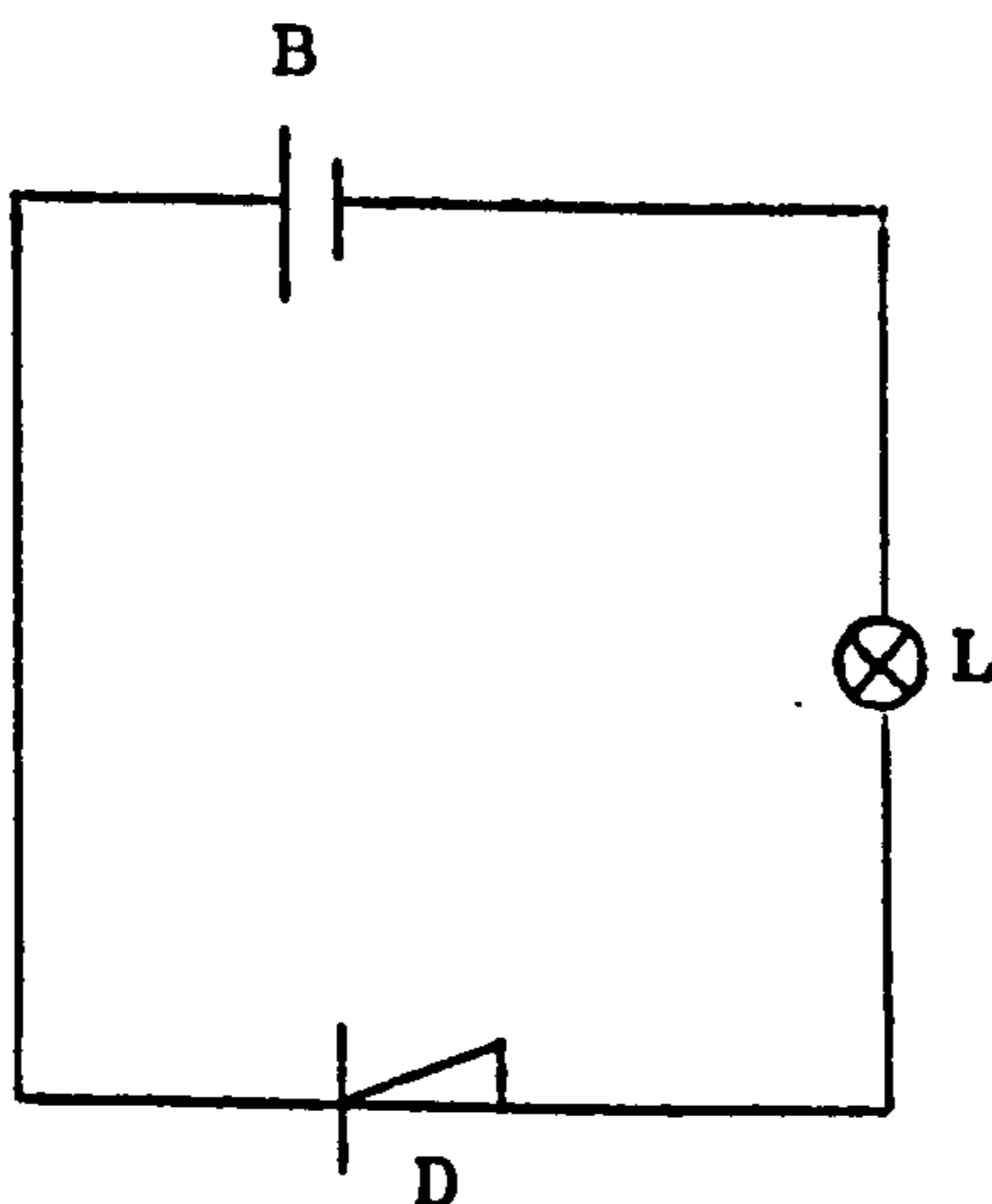

FIGURE 14 (b)

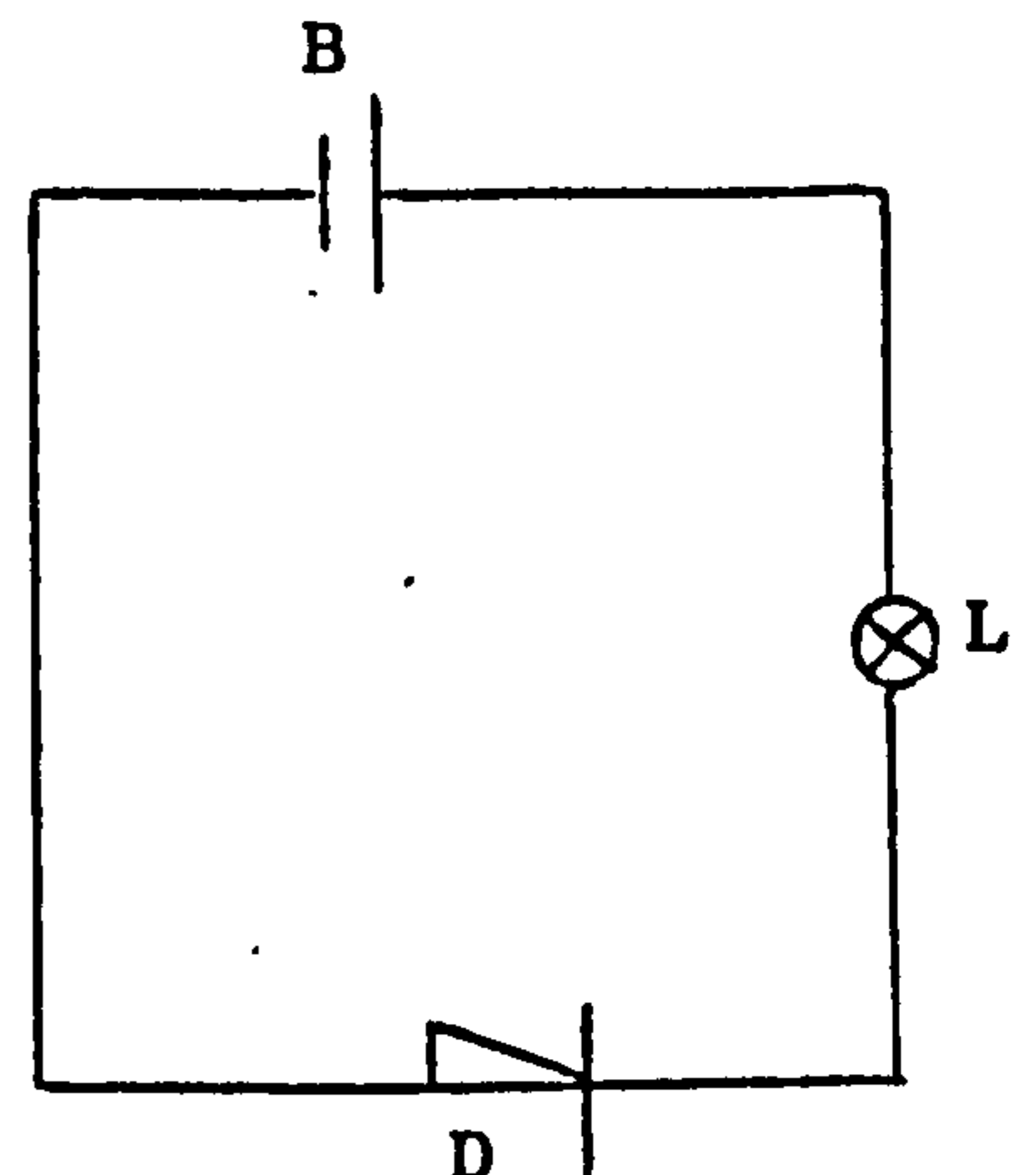

FIGURE 14 (c)

- B - 2 volt battery
- D - semiconductor diode
- L - 2 volt lamp

COMMENTS ON SAMPLE 'TEST QUESTION'

Of the above three circuits only 'a' is correct, in that the lamp would operate if the circuit functioned properly. In circuit 'b' the polarity of the semi-conductor diode is such that it opposes current flow, and so there is no current to operate the lamp. Similarly, in circuit 'c' the battery polarity, in relation to the diode, is the same as for circuit 'b' - hence the lamp will not operate. Some students suggested that the lamp will light in each case (i.e. they had not correctly grasped the way in which semiconductor diodes function). There were other students who do not see that the same condition applied in circuits 'b' and 'c' (i.e. they said that circuit 'b' would not operate but that circuit 'c' would operate, or vice-versa; because they did not fully understand the relationship between diode polarity and battery polarity). Quite often these errors and misunderstandings were rectified by either demonstrating the operation of the three circuits, or letting the students try out their own experimental circuits. Moreover, in the same process, this diagnostic exercise frequently helped to clarify the students' understanding of battery polarity, current flow and the action of semiconductor diodes.

The 'useful EFs' revealed in this case were also employed as examples to show the learners what to avoid and to make it clear why certain actions were necessary. (Similarly, when learning spelling students could be shown cases where certain errors could alter the pronunciation and meaning of a word. This exercise would have greater validity and impact if the teacher employed genuine examples of errors for this purpose). In another context, the teacher might use the strategy of giving his students certain erroneous statements, calculations, examples, and so on with the object of giving them experience of 'pitfalls'. He could also do this to test their ability in determining whether or not something is correct. Furthermore, the latter technique could be employed to discover students' depth of understanding before commencing the teaching of certain topics.

The learner himself is one the best aids for the teacher to diagnose the specific causes of EFs - since he can quickly indicate certain aspects of his errors or difficulties which would otherwise require much time and the possible use of sophisticated diagnostic tests. Unfortunately, the author has noted that the learner is often unaware of his basic misunderstanding, and so he may even unwittingly mislead the uninformed teacher concerning the root cause of his problems.

In such cases, once the EFs have been correctly diagnosed by the teacher, the student should then be clearly informed of them so that he understands the basis of his misunderstanding.

The properties and uses of what may be called 'useful EFs' were briefly mentioned earlier but their significance and value for enhancing learning has not yet been fully revealed. Regarding such EFs it is probable that the teacher would wish to identify them as they arise, since, in general, they

are only of real value when they are exploited at the right time. Therefore, if the teacher wishes to clear up a whole cluster of related errors in one process he must identify the underlying confusion at an appropriate stage. One way in which he could do this is by 'banding' his diagnostic tests, so that he detects interrelated EFs in specific 'homogenous bands' and at the appropriate time. (These aspects of the role of EFs in teaching will be discussed further in later chapters.) Finally, it should be pointed out that only guideline strategies have been proposed for the identification of EFs at this stage. However, it is suggested that the teacher formulates his own specific schemes for EF identification, within a proposed 'adaptive framework' for EF treatment. This condition would enable the necessary flexibility in teaching to be maintained, and also avoid teaching becoming somewhat rigid and stereotyped.

EF CLASSIFICATION

When undertaking the rigorous investigation of any major topic there comes a time when certain fundamental properties and criteria require to be defined and clearly established. Hence, some clear 'terms of reference' must be provided. This is nonetheless true in the case of diagnosing and analysing EFs. It is also an important requirement with respect to the scientific study of EFs in relation to the process of learning and problem solving.

However, there are a number of criteria concerning the nature of EFs which must first be identified and assessed, so that an accurate and detailed classification scheme can then be formulated. This particular action will also enable the systematization of EF diagnosis to subsequently be undertaken. The accurate classification of EFs is also necessary if we are to utilize and exploit the wider educational implications concerning the role of EFs in teaching. For instance, in the process of problem solving there are many occasions when, due to the learner mis-classifying the problem, the generalization and problem solving procedures which he employs are inappropriate. It is therefore important for the teacher to quickly detect and identify the EFs which are responsible for this. Without the provision of the kind of diagnostic and classification procedures which will be proposed, such a task would be an extremely time-consuming and difficult one for the teacher to undertake.

In formulating the basic theory concerning the classification of EFs it is essential to take account of those cases where the same underlying dimension of confusion produces different effects. For example, the same basic confusion could cause difficulties in 'skill learning' in one case and

'concept learning' in another. Therefore, it is important that the teacher is able to differentiate those effects which arise from a 'common' cause. Similarly, it is also desirable that the teacher is able to determine why a pupil employs an inappropriate analogy when identifying a problem (prior to applying, what is then, an incorrect problem solving procedure). Since this effect could be the consequence of a number of divergent EFs, it is thus very necessary that the classification system accounts for, and reflects, these variables.

It was suggested earlier that there are cases where the employment of 'learning by errors' strategies can be quite valuable. Furthermore, Lee (op.cit.) has pointed out that both 'first language' and 'second language' learners have frequently to learn through making errors. It could thus be helpful if certain 'useful EFs' were specially classified and graded, so that they may be employed for the purpose of 'learning by errors'. Moreover, in this way the student could be given valuable experience of certain EFs which he would then know how to identify, classify and correct on future occasions. (Olsson (et.al.) suggests that language learning by errors in this way is more natural and also provides the learner with more confidence, because of his experience in dealing with errors.)

An effective EF classification system should also take some account of basic differences in personality and learning styles; otherwise the scheme could create more problems than it resolves. For instance Cotterell (op.cit.) discovered that 'dyslexic' learners made similar spelling errors to normal learners but the underlying causes of these mistakes were quite different. For this reason she therefore recommends that good and bad spellers are taught separately. Thus, in classifying EFs the teacher must account for such conditions so that he subsequently employs strategies and remedial measures which are specific to the particular learning context and student. Furthermore, an EF classification scheme could also play a special role in helping the teacher to 'group' learners according to the general classes of EFs which they exhibit. This type of facility was successfully employed (although in a rather ad hoc manner) by Spector (op.cit.) when dealing with the 'patterns of difficulty' experienced by certain language learners. Moreover, if a student is given the facilities to group and classify his own EFs he is more likely to comprehend them, and this could also improve his motivation.

Theoretically, a system of EF classification, once it has been established, should continue to remain viable. However, it is suspected that, with the number and types of variables involved, and because of human idiosyncrasies, this would not really be the case. Therefore, it is

subsequently intended to present the 'skeleton' of a general scheme for EF classification, which the teacher can build upon and adapt or modify to encompass any changes in subject matter and variations in his students' backgrounds. This scheme is also intended to form an integral part of an 'adaptive framework' for EF treatment. In this way the teacher would be able to 'qualify' his EF diagnosis and then rectify the EFs more systematically (all within the same overall scheme-hence reducing the risk of ambiguity in the various aspects and stages of EF treatment). Nevertheless, it must be acknowledged that certain exceptions, concerning the treatment or properties of EFs, will possibly lie outside this framework, and so special categories of EFs may have to be accounted for separately, as the need arises. This should not actually prove too difficult a task for the teacher to undertake, since he could employ the same discrimination and assessment procedures to classify obscure EFs as he would use to classify more common or 'general' EFs.

CLASSES OF EFs

Some preliminary classes of EFs will now be proposed on the basis previously enunciated and using the evidence which has been obtained in this investigation. Following this there will be a discussion of EF classification methods and criteria which will subsequently be examined in a detailed experimental investigation. Regarding the formal classification of EFs, perhaps it would initially be more appropriate for the teacher to class EFs primarily, either in terms of their effect, or by assessing the form in which they occur. This initial distinction is suggested because it has been found that such an approach is helpful for reliable primary EF classification (i.e. it is necessary to differentiate between the basic nature of the actual EF and its effects in the learning situation). It is felt that the provision of this first broad division is also important because it establishes initial criteria, which in turn, could help to indicate the realm in which particular EFs may best be defined. Furthermore, this distinction is desirable, for reasons which will later be revealed, because it would also enable what are best described as 'dual effect', and 'dual role' EFs to be differentiated. These 'dual nature' EFs could then be more easily categorised, having established certain basic distinctive criteria.

A further significant classification grouping, which the investigations have revealed, is what may be termed as 'idiosyncratic EFs' (i.e. EFs which arise because of the idiosyncrasies of the teacher and/or learner). Moreover, this and other such classifications are essential, if the teacher intends

to regard teaching as a process rather than as a product. The latter objective also requires the fabrication of a classification system that will enable the teacher to distinguish between 'group' and 'individual' EFs which occur during the learning process. Furthermore, it has been discovered that, once these EFs have been so grouped, they may then be profitably sub-classified according to their frequency, 'sphere of influence' and so on.

The investigations which were undertaken indicate that major EF classifications should also be provided to account for 'conceptual' and 'practical' EFs. The main reason for this conclusion is that it would enable the teacher to distinguish between the effects of the same underlying dimension of confusion occurring in these different contexts (i.e. in 'practical' learning contexts or in 'theoretical' learning contexts). However, it was discovered that in order to undertake systematic EF diagnosis in those cases where there is a practical and a theoretical element in the learning situation, it is helpful, if possible, to sub-divide the major EFs which are observed to influence both 'practical' and 'theoretical' learning. For instance, in learning the theory and practical applications of the 'oscilloscope' the student must acquire both practical skill and an understanding of the theory of what he is doing. In this case the effect of the same basic EF would obviously be quite different in the skill aspect, to what it produced in the more theoretical side of this learning situation. For reasons which are not yet clear, it has also been noted that in some cases both 'theoretical' and 'practical' class 'sub-EFs' can co-exist, while in other cases only one of them appears to function at a given time.

On the grounds of clarity and precision it is proposed that certain sub-classifications of EFs which reflect their contextual origins or effects could be best left to the subject teacher to undertake. Thus, teachers of economics, would specify sub-classification criteria for EFs which would be in keeping with their own discipline. For example, a teacher of 'shorthand' would be provided with the same general EF classification criteria and groupings as a teacher of 'metalwork'. However, each teacher would adapt the 'skill' or 'conceptual' sub-classifications and so on, as appropriate to his own subject or specialisation. The inference being, that this sub-classification would then be more meaningful to both teacher and pupil (particularly during the stage of EF rectification). As will later be demonstrated, this is a further condition which should be taken into account when the teacher is constructing special objective 'EF matrices'¹ - for the purposes of EF assessment and analysis.

¹ See Figure 15 later in this chapter.

It was pointed out earlier that Levine and Schrier (op.cit.) have identified what they termed 'Error Factor Producers' (EFPs). Although the findings were determined as the result of their research with monkeys, it is felt that the fundamental concept could also be applied to the human learning context. In fact, it has been observed on a number of occasions, that certain learning styles or conditions are more conducive than others to the formation of EFs. It would therefore be helpful to account for these effects in the classification system, so that EFs could be sub-grouped according to the EFPs with which they are associated. For instance, an EF produced by 'external pressure' on the learner could be 'sub-classed' according to the factors producing the 'external pressure' such as his poor work rate, or undertaking too many learning tasks in a given time.

A further principal class of EFs, which could quite usefully be reduced into a number of sub-classes, is that of errors in 'reasoning'. One such appropriate sub-grouping for classification purposes in this context, are those errors in 'reasoning' which could be described as being 'conditional reasoning' errors. These promote incorrect deductions concerning the solving of problems, as do, but in a different way, 'class reasoning' errors. (Hence, the latter could form another sub-group of the main class of errors in reasoning.) The first sub-group of errors relate to certain erroneous reasoning conditions in general, and the latter to certain classes in general. However, further or 'tertiary' classification is also possible, and may often be necessary in order to make the EF classifications more specific to the level of subject matter being studied. The teacher could interpret and adapt these various 'tertiary' sub-classes of EF quite easily and effectively to suit his own particular students. He could then go on to produce a specific 'error matrix' based on the 'ground rules' which would be provided for him.

There are good reasons for sub-classifying EFs in terms of their effects on learning. Such conditions exist with respect to what may be called 'terminal EFs', 'dimensional EFs' and 'parallel EFs'. Each of these is a sub-class of EFs since they produce a different, and characteristic effect in the learning context. The effect of 'terminal EFs' is that they completely block further learning (this is not necessarily in only one subject area) or they may stop further progress in problem solving situations. The second sub-class of these 'effect' EFs influences performance in different dimensions of concept formation or thinking (such as restricting only 'horizontal' thinking or 'lateral' thinking). The 'dimensional EF' effects may also produce characteristic difficulties and errors in the understanding of complex or multi-dimensional subject matter. Thirdly, 'parallel EFs' are

those which result in the production of parallel or corresponding effects in different learning contexts. For example, it has been found that the same basic EF may actually promote different error paths in different subjects but produce the same end result. Perhaps there should also be a secondary EF sub-classification in this respect to account for what could be called 'virtual EFs', because these give a 'mirror image' effect of the 'parallel EFs'. However, these 'virtual EFs' appear with similar effects in the same contexts and follow by the same routes. It thus seems likely that many such 'secondary', and perhaps 'tertiary' classifications, may be required by the teacher, depending on the learning level, type of student, and subject matter.

It was discovered that, when attempting to classify EFs which result from the learner having incorrect 'whole' or 'part' concepts, it was difficult to identify whether a group of sub-EFs were responsible for this. This may have been due to the effects of 'system separation' by the student in his learning and thinking. Hence, it could be helpful if a special classification procedure is devised to determine if this has occurred. For example, it may be found by a physics teacher, that due to only understanding part of the mathematical theory of differential equations a student makes errors in solving certain current electricity problems. This could be because he was trying to solve the mathematics aspect separately from the physics and was not aware of his errors because of this isolation in his thinking. Similarly, errors due to a learner making false analogies form another major class for which it is often difficult to determine the appropriate sub-classification. For example, it is considered that the EFs associated with what can be termed 'man-made games' may arise from the same fundamental EF as those relating to 'natural phenomena'. Moreover, there is evidence to suggest that sometimes these may be the products of the same type of false analogy. In such cases, therefore, the EFs could be sub-classified in terms of their different resulting effects.

It would be of great value to have a general classification grouping to account for 'systematic EFs'. However, this classification would require careful consideration by the teacher because criteria must be established and identified to confirm that the EF is 'systematic' and not 'systemic'. Nevertheless, to be of practical use to the teacher, there must also be provided an appropriate classification for the 'systemic' type of EFs. 'Systematic' EFs could also be sub-classified and initial distinctions in this respect could be, 'semi-systematic' (i.e. only part of the EF is systematic in nature or origin) and 'practo-systematic' (i.e. the EF only affects practical aspects of a system, such as skill learning). Detailed

and more specific sub-classification of 'systematic EFs' could be devised, as required, by the individual teacher. This approach would not only reduce the possibilities of ambiguity, but also take account of particular teaching methods and learning systems. For instance, Cotterell (op.cit.) considers that the 'bad speller' will respond well to systematic remedial teaching, and perhaps 'systematic EF' rectification, which is appropriate to the particular subject, will produce similar benefits.

Finally, in the context of language learning difficulties recent research indicates that there are good grounds for 'communication' EFs to be regarded as a primary class of EFs. A further reason being that, as Brann (op.cit.) observed, many 'fundamental' language errors are basically of this type. However, it is essential that certain sub-groupings and classifications are provided in this context, so that language teachers then have a common and specific classification system available for this purpose. For example, 'communication EFs' could be sub-divided and defined as 'reading EFs', 'oral EFs', 'linguistic-interface EFs', 'interpretation EFs', and so on. The individual language teacher could eventually devise an appropriate EF 'identification analogue' for EF determination based on his experience regarding these sub-classification criteria.

EF CLASSIFICATION METHODS AND CRITERIA

The basic proposals for the classification of EFs, which have previously been expounded, are primarily intended for the identification and grouping of EFs into major categories. However, it is now necessary to consider some preliminary methods of achieving this classification in the context of learning. In this context it is considered that general cybernetic principles could profitably be employed. Using these general principles, efficient EF classification methods could be developed which would reduce the effects of ambiguity, and other potential difficulties in classifying EFs, that could arise in the classroom.

One such method, which has proved useful for the application of the EF classification scheme in advanced teaching situations, requires the teacher to observe the orientation of the learner's misunderstanding. In other words, the EFs are classified in terms of the direction of their effects on learning. This method has also been found valuable in relation to the classification of errors in reasoning. However, there are a number of learning situations where a 'qualitative' approach to EF classification would be more appropriate, for instance in relation to classifying 'idiosyncratic' EFs and 'systematic' EFs.

On the other hand a quantitative EF classification technique has been found necessary in some instances, in order for the teacher to be able to account for the differing numbers of certain classes of EFs in a particular learning context. A typical example of this type of need is that concerning the classification of the varying groups or numbers of EFs inducing (or induced by) 'system separation' effects. However, it is essential, in a given learning context, that EFs are subjected to a preliminary grouping-prior to their specific sub-classification so that the teacher can more effectively determine any 'common elements' in the group of EFs of both a single student and the class of students as a whole. This approach is also a necessary requirement because, owing to the divergent nature and the effects of some EFs, definite sub-classification is sometimes difficult until certain collective criteria have been identified and checked.

There are numerous occasions, when undertaking the classification of highly comparable EFs, which demand the use of a similar technique to that proposed by Hammarberg (op.cit.). He suggests that the teacher looks for 'non-errors' to give him clues about the nature and form of the actual source of confusion. It has also proved helpful under these circumstances if, initially at least, a 'most probable' EF classification is then employed. Alternatively, in such circumstances the teacher could apply a simple EF 'frequency table' of possible classes of EFs which could occur in a given learning context, and check each of these off using diagnostic 'test questions'. However, when dealing with the classification of obscure or uncertain EFs, it has been found helpful to discover the presence of what may be called 'complementary EFs' (i.e. EFs which occur in association with, or as a complement to other EFs). If these are found, then they often enable indirect identification and classification of obscure or latent EFs to be achieved.

When classifying EFs it could improve the efficiency of this process if the teacher first arranged them using his experience, into 'hierarchically ordered' sets so that the most significant EFs received preferential treatment. This information could also be directly employed in the construction of an 'EF matrix' as shown in figure 15, which enables precise EF analysis and classification to be obtained. Moreover, the teacher could then make use of the information obtained from this to determine the presence of what may best be described as 'EF domains'. These are boundaries within which are contained the 'collective' EFs which have been found to bridge the specific EF classifications previously defined. There are also cases where, as will be seen, due to the influence of EF 'feedback' effects, different classes of EFs can arise from a common source. This possibility

therefore demands the provision of specific 'secondary' or 'tertiary' classification tests, as will be shown later. Without these tests any method of EF classification would be unreliable and the potential value of subsequent EF rectification exercises would also be reduced.

EF MATRICES : SEE FIGURE 15 OVERLEAF

EF MATRICES

Format for analysis of ' x_n ' basic EFs and ' y_n ' primary effects of each basic EF.

| | | | | | |
|-----------|-----------|-----------|-----------|-----------|-----------|
| $x_1 y_1$ | $x_2 y_1$ | $x_3 y_1$ | $x_4 y_1$ | $x_5 y_1$ | $x_n y_1$ |
| $x_1 y_2$ | $x_2 y_2$ | $x_3 y_2$ | $x_4 y_2$ | $x_5 y_2$ | $x_n y_2$ |
| $x_1 y_3$ | $x_2 y_3$ | $x_3 y_3$ | $x_4 y_3$ | $x_5 y_3$ | $x_n y_3$ |
| $x_1 y_4$ | $x_2 y_4$ | $x_3 y_4$ | $x_5 y_4$ | $x_5 y_4$ | $x_n y_4$ |
| $x_1 y_5$ | $x_2 y_5$ | $x_3 y_5$ | $x_4 y_5$ | $x_5 y_5$ | $x_n y_5$ |
| $x_1 y_n$ | $x_2 y_n$ | $x_3 y_n$ | $x_4 y_n$ | $x_5 y_n$ | $x_n y_n$ |

Figure 15

Key Horizontal rows are different EF producing similar effects.
Vertical columns are different effects produced by the same basic EF

Matrix need not be square i.e. it can have more rows than columns or vice-versa.

CONCLUSIONS REGARDING EF CLASSIFICATION

An important conclusion regarding the employment of the suggested strategies for EF classification is that this could provide the key for the formulation of a precise system for EF diagnosis. An EF classification scheme could also be used as a source of reference for a given learner's EFs in different subjects. The latter information would be useful for the construction of a special EF rectification 'framework' for use with 'generalized' EFs or multi-subject EFs. However, it should be stressed that, in fabricating any 'models' of EFs in this respect, since they have a mercurial nature and thus they require flexible treatment - with frequent review and appraisal by the teacher. It has also been observed that, when he is investigating EFs the teacher may, in certain situations, actually create or modify the EFs. Hence, he may need to take positive steps to avoid this possibility or make certain allowances for it in his EF classification.

It was explained earlier that errors can 'complement' the truth; it could thus be found that certain classes of EFs may be usefully employed to reinforce some aspects of learning. For instance, there could be a certain group of 'useful EFs' selected from different classes of EFs in basic arithmetic to bring out certain major points in teaching arithmetical subtraction. However, such applications require positive EF classification to be undertaken by the teacher, and he must be able to fully replicate the particular classes of 'useful EFs'. Nevertheless, by using classification procedures such as those previously described, the author has found that this exploitation can be efficiently carried out. Moreover, if these 'desirable' classes of EFs are not found to be present in a particular learning context it may be possible for the teacher to artificially promote them.

The employment of cybernetic principles for EF classification, which was mentioned earlier, could also have great potential as the basis of a computer-assisted EF classification technique designed for use in the classroom. (Brown and Burton (op.cit.) have devised such a system for use with errors and misunderstandings in arithmetic.) By employing this approach the teacher could devise his own system for the 'cross-classification' of complex EFs and, as more data is obtained, he could systematically predict the frequency of certain classes of EFs. Similarly, the disastrous effects of 'EF loops', which result from self perpetuating or 'cyclic' EFs, could, perhaps, be avoided by the teacher using the same principles which are employed in computer programme systems. The method envisaged would involve the adaptation of these principles for both EF classification and rectification

strategies - with the result that the teacher could, therefore, prognosticate concerning 'EF loops' and hence take steps to avoid them. Similarly, the selection of 'useful EFs' of different classifications could be achieved more efficiently if 'computer logic' principles were appropriately rationalised and used for this purpose. As an alternative, these principles could be adapted so that EF classification would cater for the identification of 'imaginative EFs' (i.e. EFs which reinforce or enhance learning when the necessary complementary conditions are made readily accessible by the teacher).

As will subsequently be demonstrated there is also much to be gained, in the context of EF classification, from studying what are known as 'master performer' techniques. (i.e. the approach employed by experts in particular fields.) The author supports the view of Gilbert (op.cit.) that special reference should be made to examining 'master performer' techniques for identifying, classifying and exploiting or avoiding errors. Particularly since, as Gilbert demonstrates, the classification of even minor EFS can take an inexperienced person a considerable amount of time. Such a study of 'exemplars' could also provide valuable 'comparative' data regarding their EF classification techniques which could then be compared to those which are used by (or provided for) learners. However, it must be emphasised that, how to efficiently classify EFs is different from how to avoid them.

Another significant conclusion regarding the classification of EFs is that, as with any new system or technique, there is a danger of the proposed measures not being correctly applied (thus perpetuating the confusion or introducing further misunderstanding). Such a possibility is illustrated, on an extended time scale, by the many examples in science where the misapplication of new laws or classification systems have perpetuated those same problems which they were intended to resolve. This important philosophical point will be returned to in a later chapter. For these reasons the EF classification system should have certain implicit 'control factors' incorporated to immediately reveal any misunderstandings and inappropriate EF classifications. The provision of such a safeguard should mean that even a relatively inexperienced teacher could confidently classify and then treat or exploit the EFs of his students. Moreover, after collating and analysing the data on learning difficulties, which an efficient EF classification system should provide, the teacher would then be able constantly to improve his EF identification and treatment procedures.

A particularly important consequence, which could arise from the provision of an EF classification system for the teacher, is that it may

result in improving his awareness of what could be described as 'resonant EFs'. These are a hybrid form of EF - the effects of which have been found to be amplified in certain learning situations. Hence, if there were some information and provision in the EF classification criteria which would make these undesirable effects known, then the teacher should be able to identify these EFs more clearly.

Finally, it is possible that the EF classifications which have been proposed could also be employed for the resolution of particular sequences of difficulties in learning. The insightful teacher could achieve this by correlating the errors made by a learner (or group of learners) to discover the existence of any 'common denominator' in the sequence of EFs. Furthermore, if the teacher was given definite criteria such as that suggested for EF classification, he should then be able to employ elementary statistical techniques to pinpoint and predict learners' EFs. Moreover, as Lewis and Pask (op.cit.) point out, the teacher could also identify the frequency of a particular class of major EFs, using measures such as proposed earlier, and thus obtain an order of priority for EF correction. Observations and empirical evidence, regarding the viability of the various proposals and conclusions, will be provided by the following detailed pilot investigation which will be followed by a major experimental investigation that will be presented in Chapter 4.

PILOT EXPERIMENT

GENERAL REMARKS

It is intended that more decisive evidence will now be provided by the following detailed pilot experiment, along with the presentation of a clear picture concerning the practical role of EFs in teaching. After this evidence has been analysed it is hoped to demonstrate that their role is both significant and comprehensive. Fresh evidence and ideas resulting from this study will later be employed both in the formulating of a major experiment and the sketching of a 'general theory' of EFs, since at the moment, there is no such general theory. Moreover, it is hoped to provide initial evidence for the belief that, what is being advocated is a scientific theory of EFs in the sense of the term 'scientific' as proposed by Popper (op.cit.). In his words:

"Falsifiability is the criterion of demarcation between science and non-science".

Furthermore, it is intended that this pilot experiment will help to demonstrate that there is little value in the teacher merely noting that a particular learner (or group of learners) has made a certain number of errors. This is because the counting up of errors, say in arithmetic, only reveals the number of errors not the number of causes. It hoped to show that what the teacher needs to discover is why these errors occur, and whether they are the result of single or multiple confusion.

BACKGROUND AND INTRODUCTION TO EXPERIMENT

BASIC DETAILS

In this pilot analytical examination, the specific 'learning difficulties' experienced by a group of 17 Automobile Engineering students, studying electric circuits as part of their First Year Physics Course, were investigated. Moreover, various hypotheses regarding the nature of EFs were also explored. These tasks were undertaken using the strategies for the treatment of EFs which were previously described.

SUMMARY OF AIMS AND EXPERIMENT

This investigation was carried out with the aim of detecting and identifying the EFs which were responsible for certain learning problems

which were anticipated with respect to various electrical and electronics topics. The main reason for this was because it had been observed that a number of previous groups of students did not complete the physics syllabus satisfactorily (it was suspected that this result was due to confusion only concerning some of the topics being learned). However, for various reasons, the basis of these problems had not been identified, and therefore they remained unresolved by the lecturers concerned. In order to satisfy these and other objectives, which will shortly be explained, each facet of the learning situation was carefully subjected to a comprehensive investigation during the two academic terms in which this study was undertaken.

All the relevant evidence or findings from this experiment will be outlined, along with detailed explanations and analysis of data concerning the nature of EFs in this context. With the aim of clarifying this objective, references will be made to some sample diagnostic 'test questions' which were employed (chosen to illustrate the various techniques and methods of investigating or treating EFs that were used). The evidence concerning EFs which was obtained from the various tests will be carefully examined and then conclusions concerning these will later be drawn. It will also be demonstrated how 'feedback', and certain information gained by elicitation from detailed discussions with the students regarding their errors, can be employed in EF diagnosis. However, various special steps were taken in the preparation of the diagnostic 'test questions' to ensure that these were not themselves sources of confusion for the students. Similarly, any preconceived ideas on the part of the investigator, regarding possible EFs, were not allowed to bias the construction of these diagnostic questions (which could thus exclude certain other EFs from being detected). Nevertheless, evidence concerning 'learning difficulties', which was noted from previous groups, was taken into account at appropriate stages.

Another major objective was that the investigation should assist in the provision of further information regarding the nature and types of EFs in the wider context of learning. Measures were taken in the design of the experiment to avoid any potential threats either to its validity or to the generalization of the results. Moreover, during the experiment, various EF rectification and removal techniques were investigated to determine their relative suitability in this particular context. It was also intended that the lessons learned from this initial study would subsequently be applied to a further detailed pilot study in a different learning context, prior to a major investigation of EFs.

STUDENT DATA

Number in Group : 17 male students
Average Age : 18 years
Basic Attainment : G.C.E. 'O' level in physics, mathematics, etc. (Students also given an 'entry test' at start of course)
Year of 'Course' : 1st year
Background : All but 5 students in the group were of British origin.

OUTLINE OF THE COURSE

There are special reasons, in addition to those given earlier, why this particular course was selected for detailed study. One such reason is that this physics course is intended to provide the student with both practical skills and an understanding of the behaviour or properties of certain electrical and electronic circuits (relating to the automobile.) It is taught against the background of separate, but corresponding, courses in 'automobile electrical technology'. Moreover, much of what these students are required to learn is important in preparing the ground for their more advanced studies in the Second Year of this course. Hence, there is a dual requirement for the transfer of learning in this case. Some motivation is provided by this condition and by the fact that most of the students are offered good jobs if they are successful in passing the course and obtaining their Diploma.

THE LEARNING ENVIRONMENT

All the teaching for this course was carried out in modern well-equipped laboratories. The students were taught this particular topic once per week, over a period of twenty weeks. A 'time limitation' problem existed due to the fact that this course was originally designed for a duration of 2 hours per week, but a few years ago this was reduced to 1½ hours per week (without a corresponding reduction in the syllabus). The method of teaching which was employed involved a combination of lecture/demonstrations and discussions with the students (after they had carried out certain 'learning by discovery' type experiments in electricity and electronics). In view of the limited

time available, and the nature of the subject matter, the undertaking of any effective 'remedial' work posed a number of difficulties. Moreover, it was made even more difficult by the requirement that a large portion of the syllabus had to be covered at all costs, prior to the 2nd Year of the course. After the completion of each major topic, various short 'attainment tests' were set. A certain number of these were 'multiple choice' or 'short answer' questions - while other 'long answer' type questions (including more difficult problems, which required calculations to be undertaken) were given as 'homework'. However, as stated earlier, the tests and questions which were given during the investigation were carefully designed to have diagnostic properties in order to indicate both attainment and the occurrence of EFs at various stages.

EXPERIMENTAL METHOD

The investigation was carried out in two main parts (A and B), each of which covered different related stages of the required learning. In order to pinpoint any possible basic causes of confusion at each stage, it was decided to analyse the results of a selection of the diagnostic 'test questions', using only the students' incorrect answers for the purpose. The EFs identified by this procedure were then subjected to further investigation, using an 'elicitation technique' to discover their origins. Some sample 'test questions' will be included in the subsequent discussion to indicate the forms of diagnosis which were employed, and following each 'test question' there will be explanatory comments.

The corresponding empirical data, concerning the number and frequency of EFs revealed by the tests, will be provided later in this Chapter (see separate tables). This evidence was used, along with other relevant information (e.g. from student 'feedback') to classify the EFs and enable any pattern of EFs to be identified. This exercise also provided an opportunity to validate some of the EF classification measures previously advocated. On the basis of the diagnostic evidence which was obtained, appropriate EF correction measures were then undertaken. The relative effectiveness of these will be assessed and conclusions concerning EF detection, diagnosis and rectification will be drawn at the end of this section.

PART 'A'

EXAMPLES OF DIAGNOSTIC 'TEST QUESTIONS' ON 'FAULT IDENTIFICATION IN SERIES CIRCUITS'

Basic Objectives:

To determine the students' ability to identify faults occurring in series circuits; to detect the presence of errors or confusion and to diagnose the basis of their misunderstandings in this context.

TEST QUESTIONS: PART 'A'

TOPIC 1

- (i) In the circuit shown the ammeter (A) fails to read when the switch (S) is closed. However, when a voltmeter (V) is connected across the indicator lamp (b) it reads 12 volts. What is the fault in this circuit? Give reasons for your conclusions in this respect.

TOPIC 2

- (i) Following the rectification of the above fault, the ammeter (A) reads 0.1 Amps and the potential difference across the lamp (b) falls to 11.7 volts. Is the system now working correctly? Explain your decision about this?

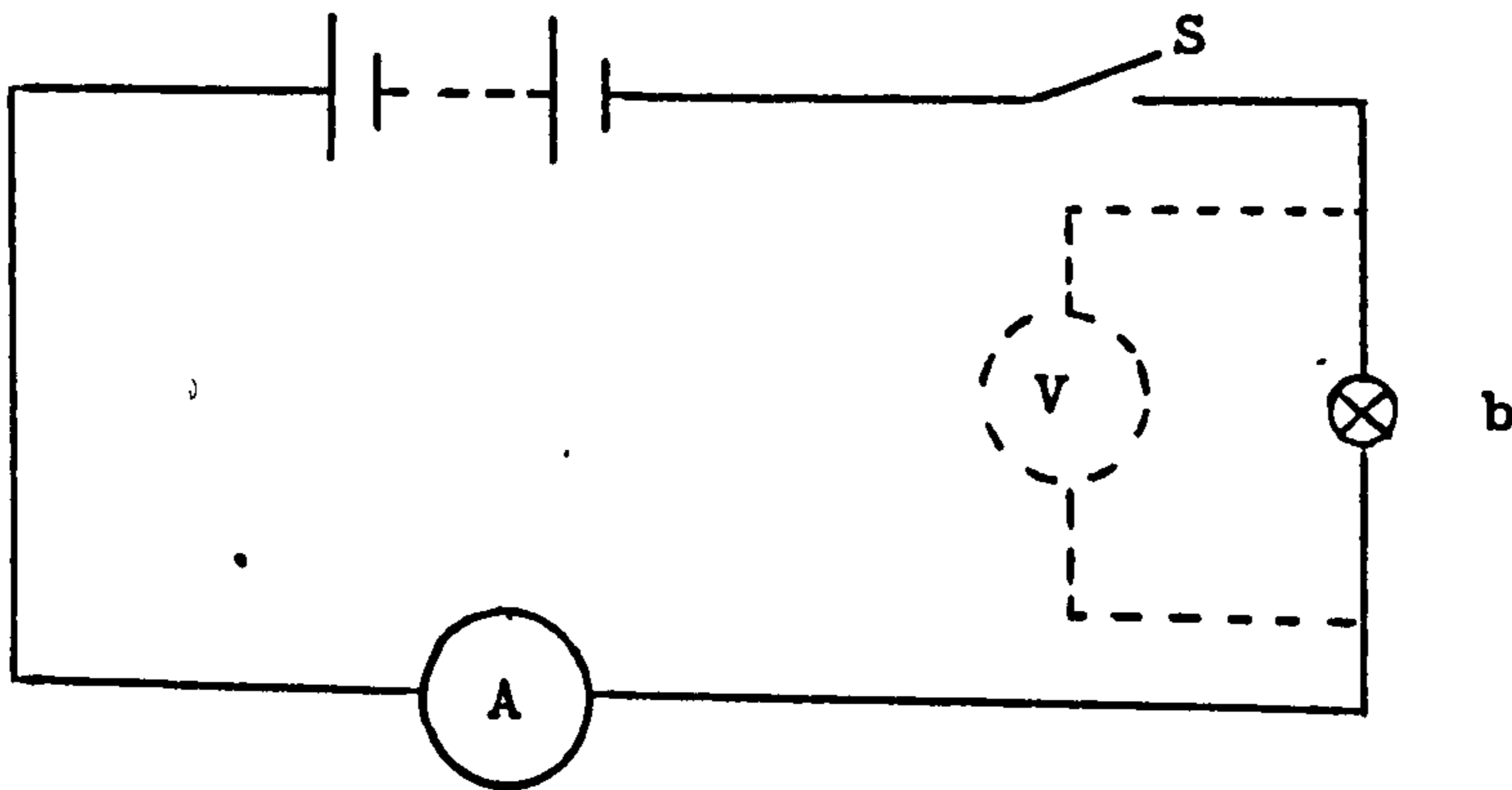

FIGURE 15

COMMENTS ON THE SAMPLE 'TEST QUESTIONS' IN PART 'A'

Both the 'test questions' on topics 1 and 2 have been chosen because they

clearly illustrate the diagnostic objectives previously stated (they are each typical of the other 'test questions' which were devised for these topics). By asking the students to give reasons for their answers to questions, such as with the sample question on topic 1, any basic errors in their reasoning should be disclosed. With 'test questions' like the question on topic 2 the students were not told whether the circuit was working correctly or not - which meant that their answers would show whether they really understood the nature of such circuits. If they did not, then their erroneous explanations (which were asked for in order to enable the basis of their errors to be identified) also gave valuable evidence concerning the extent of their misunderstandings.

Even if the students had guessed the correct answers to the 'test questions' on these topics, the explanations required of them should indicate their underlying ignorance and confusion. Questions such as that on topic 2, were also employed because they require the students to discriminate between correct and incorrect circuit behaviour. As previously reported, this is a particularly important diagnostic test - especially since in the past it was suspected that previous groups of students failed to understand this correctly. The detailed study of the students' attempts to do this, and their explanations in this respect, also helped to pinpoint the source of their difficulties.

SUMMARY OF RESULTS

Test Questions on topic 1

The data provided in Table 1 shows that 10 students were incorrect in identifying the fault in the 'series' circuit in question (i). These 10 students were also wrong in their answers to a set of 'multiple choice' questions and four longer type 'test questions' on such circuit faults. Subsequent analysis (see Table 2) revealed that a group of 4 students could offer no valid reasons for their erroneous conclusions - they considered that there were no faults in all the circuits in question. A second group, comprising the remaining 6 students all were found to have wrongly answered that such circuit faults lay in the meters used in the various circuits. (They all made the same type of errors in answering other 'test questions' on this aspect.) These results indicate that, although there was a general misunderstanding concerning electric circuit faults, this probably arose from two different underlying EFs.

RESULTS OF DIAGNOSTIC TESTS

TABLE 1

Total number of students:- 17

| <u>Topic/Question</u> | <u>Total number making errors</u> | <u>Number with same error</u> | <u>Other Errors</u> |
|-------------------------------------|-----------------------------------|-------------------------------|---------------------|
| <u>TOPIC 1</u> <u>(PART 'A')</u> | | | |
| Question (i) | 10 | 6 | 4 (all same |
| (ii) | 10 | 6 | 4 " error) |
| (iii) | 10 | 6 | 4 " " |
| (iv) | 10 | 6 | 4 " " |
| (v) | 10 | 6 | 4 " " |
| (vi) | 10 | 6 | 4 " " |
| <u>TOPIC 2</u> <u>(PART 'A')</u> | | | |
| Question (i) | 11 | 10 | 1 |
| (ii) | 11 | 10 | 1 |
| (iii) | 11 | 10 | 1 |
| (iv) | 11 | 10 | 1 |
| (v) | 11 | 10 | 1 |
| (vi) | 11 | 10 | 1 |
| <u>TOPIC 3</u> <u>(PART 'B')</u> | | | |
| Question (i) | 10 | 6 | 4 (all same |
| (ii) | 10 | 6 | 4 " error) |
| (iii) | 10 | 6 | 4 " " |
| (iv) | 10 | 6 | 4 " " |
| (v) | 10 | 6 | 4 " " |
| (vi) | 10 | 6 | 4 " " |

Test Questions on topic 2

The data concerning question (i) on this topic, and five corresponding 'test questions', reveal that 11 students were unable to answer any of these 'test questions' correctly. Closer examination of Table 2 shows that 10 of these students were the same ones who failed to correctly answer questions on topic 1, such as 'test question' (i) previously described. However, more detailed investigation is required before any definite suggestions concerning the full significance of these observations can be made. It should also be pointed out, that not just 10, but all 11 students gave the same type of incorrect answers for the explanations of their decisions about the circuits. It appears that there could be a universal source of underlying confusion to be identified in this context.

PRELIMINARY ANALYSIS OF EFS: PART 'A'

TOPIC 1

In view of the fact that 4 students incorrectly believed that there were no faults in any of the circuits, and 6 students suggested faults which did not apply, there does not appear to be a common source of confusion on this topic. However, both groups really demonstrated, but in different ways, complete misunderstanding of electric circuit faults. For example, by not understanding that the fault in the circuit in 'test question' (i) was due to the lamp, both groups of students showed common ignorance as to the cause of such faults. In order to reinforce this conclusion, all 10 students were asked to say, in their own words, what would happen if the fault in the circuit was due to the lamp (which it was in fact). None of the 10 students could explain the effect correctly. Therefore, even though their ignorance had led them to suggest two rather different incorrect answers to the 'test questions', it was obviously due to the same basic lack of understanding of circuit faults.

As it was known that the 10 students had been told of this type of circuit fault earlier in the course this EF diagnosis thus suggests that, for some reason, they had either not correctly learned it or had forgotten it. This possibility was discussed with the 10 students at the next lecture, and after probing various possibilities using an elicitation technique, as described earlier, it was found that none of them really understood why a voltmeter gives a reading across a faulty component in a circuit such as shown in Figure 15. Perhaps this finding is not surprising since it was

next discovered that they also could not explain what the voltmeter is really measuring in these circumstances. These 10 students were therefore basically confused about the concept of 'voltage' in this context. It appears that this may not have been fully explained to them in their first studies of circuit electricity. Hence, this small gap in their understanding has created all the subsequent confusion and errors. This fact was soon confirmed by further specific 'test questions' and it amazed the students when it was finally pointed out to them.

EF RECTIFICATION

The 10 students previously referred to were given a brief explanation, and one or two simple demonstrations, in order to correct the 'fundamental' gap in their understanding which was responsible for all their errors in this context. The effectiveness of this rectification exercise was then validated by asking the student to:

- A. Explain the effects of certain faults in 'series' electrical circuits (in their own words).
- B. Answer 'test questions' similar to those which they had previously failed to give correct answers.
- C. Explain the concept of 'voltage' - which they did not previously understand (again in their own words).

The students' subsequent correct answers to the 'validation questions' on circuit faults and voltmeters confirmed the success of this rectification exercise in clearing up all their associated errors. This particular finding has further reinforced the need for better structuring in the teaching of complex subjects like electricity - in order to prevent the development of such difficulties at an early stage.

PRELIMINARY ANALYSIS OF EFs

TOPIC 2

It is shown in Table 2 that 10 of the 11 students who wrongly answered 'test question' (i) on this topic (and 5 similar 'test questions') were the same ones who had difficulties with questions on 'series' circuit faults, such as 'test question' (i) on topic 1. In view of the earlier evidence it is likely that their wrong answers to 'test question' (i) on topic 2, and corresponding questions, could possibly be a result of the same misunderstanding as for 'test questions' on topic 1. Therefore, the 10 students were questioned further and then tested, to confirm this conclusion. This was confirmed and so these 10 students had no difficulty now in correcting their answers to this and other 'test questions' on this further aspect. However, there was one additional student (student 'q' in Table 2) who had not been correct in his answers on this aspect, but had made no apparent errors when answering 'test questions' on topic 1. It was therefore necessary to analyse the basis of his misunderstanding, this was done as follows:

A closer examination of the errors which this student made revealed that he appeared to believe the circuit in Figure 15 was not working correctly because the ammeter reading was 'low'. However, after he was informed that the ammeter was not reading low, for this type of circuit, he said that he thought the lamp should take more than 0.1 amperes from the battery. When asked why he thought this, he answered that he had always expected a lamp to draw more current than this. He added that, in his experience, this was always the case. When it was pointed out to him that in the experiments which he carried out earlier in the term, he had measured the current used by such lamps, the student then said that he thought that the meter which he had used was merely reading low. Thus, by having too limited a knowledge or experience of such circuit properties, the student held the wrong belief that values of current used by lamps are always higher than those which were stated in the questions.

EF RECTIFICATION

After demonstrating to this student that his belief was not true, he immediately became aware of his erroneous concept, and made no subsequent errors in answering further 'test questions' in this respect. There is obviously some merit, for the diagnosis and complete rectification of this

type of EFs, in the employment of 'test questions' such as question 2(i) which test the students' understanding of phenomena or behaviour in the wider context.

PART 'B'

EXAMPLES OF DIAGNOSTIC 'TEST QUESTIONS' ON 'BATTERIES IN SERIES CIRCUITS'

Basic Objectives:

To test the students' depth of understanding of cells and batteries in 'series' circuits, and to identify their EFs in this context.

TOPIC 3

- (i) In the circuit shown in Figure 16 cell 'C' is connected in opposition to cells 'A' and 'B'. What is the total 'e.m.f.' (electro-motive force) and total internal resistance of this arrangement? Give an explanation of your answer in each case.

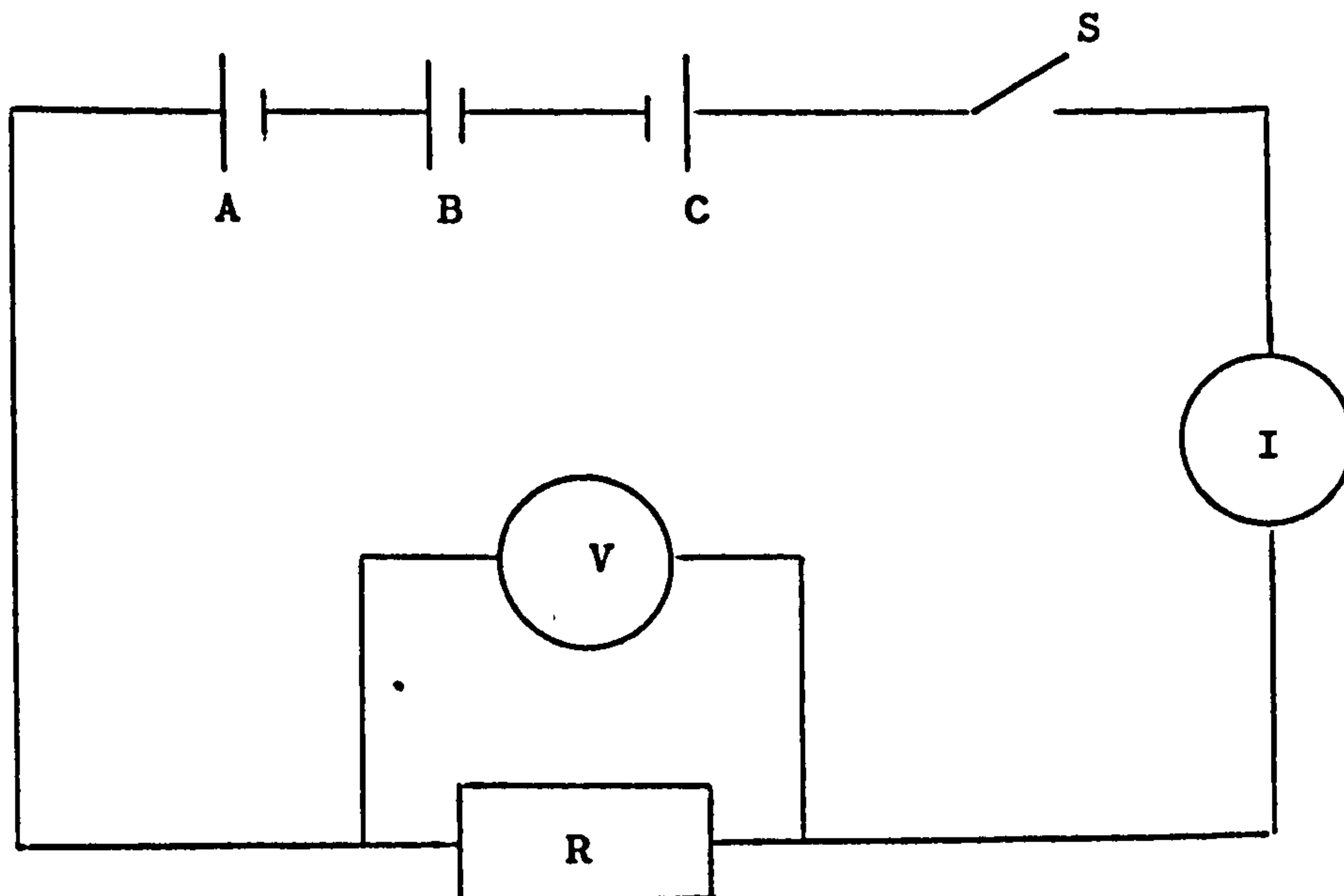

FIGURE 16

COMMENTS ON SAMPLE 'TEST QUESTIONS' IN PART 'B'

Test question (i) like the other diagnostic 'test questions' on topic 3 was designed to look for errors arising from limited depth of understanding. It also requires an explanation of the answers by the student in order to reveal other aspects of his possible confusion. Any misconceptions in this context should then be more easily detected after examining the student's explanations. It was also intended that these 'test questions' would help to pinpoint errors due to the student not having a complete understanding of the inter-relationship between e.m.f. and internal resistance (which the investigator has found is not otherwise very easy to identify).

SUMMARY OF RESULTS: PART 'B'

Analysis of the data in the results Table 1 indicates that 10 students gave incorrect answers to question (i) and other corresponding 'test questions' on topic 3. It is shown in Table 2 that of these 10 there were 6 students who also gave wrong answers concerning the total internal resistance in such circuits. Therefore, it was decided to examine these two errors separately. Nevertheless, it was acknowledged that the two errors could be inter-related, and so this possibility was also explored later. The fact that these 10 students were the same ones who had showed confusion concerning 'test questions' on topics 1 and 2 in part 'A' was taken into consideration when determining the underlying dimension of confusion.

PRELIMINARY ANALYSIS OF EFS: PART 'B'

TOPIC 3

It was found that the 6 students who determined incorrect values for the total 'e.m.f.' in circuits such as that shown in Figure 16, all did so basically because they had made the error of adding the individual e.m.f.'s in each case. Their explanations for employing this approach suggested that they believed this was the correct method to employ (since, even though one cell was connected in opposition, they thought that its e.m.f. was still to be added to the other cells in the same way). What this incorrect explanation clearly indicates is that the 6 students did not fully understand the concepts of e.m.f. and terminal potential difference. If the 6 students had a more complete understanding of these factors they would not have made these particular errors.

Therefore, it was a lack of either knowledge of e.m.f.'s and/or a poor understanding of the processes involved, which created these particular EFs. Furthermore, since e.m.f. and internal resistance of cells are so closely related, then perhaps, this could also be the reason for their errors concerning 'test questions' on total internal resistance in circuits. In view of this possibility, it was decided that it would assist in the final diagnosis of their basic EFs if all the 10 students' errors concerning total internal resistance were next analysed.

A preliminary examination of the 10 students' answers revealed that their errors actually had two different origins. What is significant in this respect, is that 6 of these 10 students who made errors in this context, not only all did so for the same basic reason but were also the same students who had made errors concerning the total e.m.f. in 'series' circuits (which were previously discussed). After further specific questioning and detailed consideration of their explanations (on the basis of this additional evidence) there was no doubt that their underlying confusion about e.m.f.'s had produced their other errors concerning internal resistance in these circuits. What their later explanations revealed was that since they had fundamentally wrong ideas about the total e.m.f. in a 'series' circuit, then this had caused them to have correspondingly wrong ideas concerning total internal resistance in such circuits. Therefore, the 6 students' failure to understand this one basic 'part' of the underlying theory (which had occurred for some reason during their earlier studies) had resulted in their difficulties concerning other associated 'parts' of electric circuit theory and its application.

Regarding the errors of the remainder of this group, these 4 students were asked for more detailed explanations of their methods and answers. These erroneous explanations all suggested that their failure to understand the 'whole' concept of circuit behaviour had created their problems with this particular aspect of electric circuitry. Hence, this explains why they had been correct in answering questions about total 'e.m.f.' but had displayed erroneous reasoning concerning total internal resistance, since the latter stemmed from confusion regarding the 'series' circuit as a 'whole' (and a misconception of the inter-relations in 'series' circuits between different parts). This type of misunderstanding could be quite difficult for the teacher to identify, if this task was attempted in isolation from the series electric circuit as a whole. However, because the diagnostic 'test questions' required explanations of the answers regarding cells in 'opposition' (as well as in 'normal' arrangement) then this strategy helped

to reveal and confirm the deficiencies in the student's understanding of the full or 'whole' situation, regarding basic electric circuit properties.

EF RECTIFICATION: TOPIC 3

Rectification of the EFs for the first group of 6 students who made common errors (comprising students a, b, f, k) was done by 'telling' them about the situation more fully so that they acquired a better understanding of e.m.f. This was reinforced by demonstrating the various properties with the aid of experiments. These 6 students were then asked to apply this understanding (with some initial guidance) to explain internal resistance and the inter-relation of this with e.m.f. in different 'series' circuits. They were successful in all these tasks and in correctly defining internal resistance - which they had not previously been able to do, due to their basic confusion. The student 'feedback' from this EF rectification exercise indicated that the 6 students' underlying confusion regarding e.m.f. probably originated from their teachers not having told them about the particular situation when cells are connected in opposition in circuits. It was quite clear, from their rapid success and achievements after being given this fuller explanation, that if this had been explained at the initial stages of their learning, then the other errors and difficulties would not have occurred.

For the second group of 4 students EF rectification was carried out by a type of 'Socratic' method which required them to use their existing understanding of e.m.f.'s. By guidance and 'prompting' they were then able to explain 'internal resistance' and the inter-relation of this with e.m.f. Hence, these 4 students had some understanding in this context but were unaware of how to use this understanding. This latter exercise was done in conjunction with the first group of 6 students (who had by now been told about e.m.f.'s so that they too comprehended them). In other words, their 'partial understanding' was widened, deepened, and then extended with only a little help, to enable them to comprehend the 'whole' situation. The 'higher order' EFs displayed by the second group of 4 students, thus resulted from two earlier deficiencies in their learning about this topic. First, they had really been given too narrow an understanding of the concept, and secondly, their basic learning had not been done in a well structured system, which allowed 'transfer' and extension of their understanding to develop. However, by using diagnostic questions on topic 3, such as 'test question' (i), the teacher should find it possible to quickly identify these classes of EFs. Once this is done EF rectification is generally quite a straightforward exercise.

ANALYSIS OF ERRORS IN PARTS 'A' AND 'B'
CONCERNING CURRENT ELECTRICITY

TABLE 2

Based on diagnostic 'test questions' given on topics 1, 2 and 3.

Each of the 17 students in the group is identified by a letter. Student number 1 is referred to as 'a' and so on.

| Topic/ 'Test Question' No. | (I) List of students making <u>same</u> error | Total | (II) List of students making <u>same</u> error but different to column I | Total |
|----------------------------------|---|-------|---|-------|
| <u>TOPIC 1</u> | | | | |
| Qu. No. (i) | e, g, h, n, o, p | 6 | a, b, f, k | 4 |
| (PART (ii) | e, g, h, n, o, p | 6 | a, b, f, k | 4 |
| 'A') (iii) | e, g, h, n, o, p | 6 | a, b, f, k | 4 |
| (iv) | e, g, h, n, o, p | 6 | a, b, f, k | 4 |
| (v) | e, g, h, n, o, p | 6 | a, b, f, k | 4 |
| (vi) | e, g, h, n, o, p | 6 | a, b, f, k | 4 |
| <u>TOPIC 2</u> | | | | |
| Qu. No. (i) | a, b, e, f, g, h, k, n, o, p | 10 | q | 1 |
| (PART (ii) | a, b, e, f, g, h, k, n, o, p | 10 | q | 1 |
| 'A') (iii) | a, b, e, f, g, h, k, n, o, p | 10 | q | 1 |
| (iv) | a, b, e, f, g, h, k, n, o, p | 10 | q | 1 |
| (v) | a, b, e, f, g, h, k, n, o, p | 10 | q | 1 |
| (vi) | a, b, e, f, g, h, k, n, o, p | 10 | q | 1 |
| <u>TOPIC 3</u> | | | | |
| Qu. No. (i) | e, g, h, n, o, p | 6 | a, b, f, k | 4 |
| (PART (ii) | e, g, h, n, o, p | 6 | a, b, f, k | 4 |
| 'B') (iii) | e, g, h, n, o, p | 6 | a, b, f, k | 4 |
| (iv) | e, g, h, n, o, p | 6 | a, b, f, k | 4 |
| (v) | e, g, h, n, o, p | 6 | a, b, f, k | 4 |
| (vi) | e, g, h, n, o, p | 6 | a, b, f, k | 4 |

ANALYSIS OF RESULTS OF PILOT STUDY

One of the most significant consequences of this study is the fresh information and evidence which it provided concerning EF generation or production. For example, in the analysis of the students' errors on topic 1, such as for 'test question' (i), it was found that a great deal of peripheral confusion resulted from a single misunderstanding during earlier learning. This emphasises the need for early EF detection, so that prompt EF rectification may be undertaken to prevent 'higher order' type EFs from developing. Another interesting observation regarding the empirical data shown in Tables 1 and 2, is that there was great similarity in the various errors made by the group as a whole. Apart from the few exceptions mentioned, for example with 'test questions' on topic 2, the students' errors on the same topics were found to be frequently identical in their origins. Perhaps, after further research has been undertaken in this respect, detailed lists of common or 'universal' EFs for a particular subject and level could be drawn up for the teacher. This information could also be employed by the teacher in designing more efficient diagnostic tests for EFs rather than relying on intuition alone.

CLASSIFICATION OF EFs IN THE PILOT EXPERIMENT

Various types and forms of EFs were identified in this study and an attempt will now be made to classify these according to the criteria for EF classification suggested earlier in the chapter. Foremost in this context are what could be classed as 'Fundamental' EFs which were identified with regard to 10 students who all displayed a fundamental misunderstanding of topic 1. However, there were 6 of these students whose EFs on this topic could be sub-classified as 'virtual EFs' because their EFs produced 'mirror image' effects of those of the other 4 students. In addition, there were what may be classified as 'surface' type EFs clearly identified in this investigation - such as those detected in the case of the student who had too limited knowledge concerning electric circuit properties identified in topic 2.

Perhaps it might be more helpful in future to classify those EFs which were identified by 'test questions' such as those on topic 3 in part 'B' (regarding e.m.f's) as 'EF catalysts'. This is because their presence caused further problems for those 6 students, whose errors were identified by 'test questions' on topic 3 when they were later learning about the internal resistance of cells. However, there were 4 other students who did not appear to have this same confusion about e.m.f's, who, nevertheless, made errors concerning internal resistance in 'series' circuits. This was because they

only possessed a partial understanding of e.m.f's, not because of the 'EF catalyst' which affected the other 6 students. Such EFs could also be difficult to classify if the special diagnostic measures had not been employed. Neither of these two groups of students, would have made all the other errors in this context if they had had a more complete and broader understanding of e.m.f's. Nevertheless, after rectifying this basic situation it was found that all associated classes of EFs were resolved in the same process.

ANALYSIS OF DIAGNOSTIC MEASURES EMPLOYED

Several helpful discoveries, in relation to the formulation and defining of objectives for diagnostic tests for EFs, were made as a consequence of this investigation. For example, the results which were obtained have shown the value of employing diagnostic 'test questions' which are really tests of ignorance for the complete detection of EFs (rather than depending upon tests of knowledge and understanding or upon intuitive measures). However, it is felt that these tests should be reinforced by other tests and diagnostic measures, for reasons which will be more fully explained later, so that the basic source or cause of ignorance can be identified by the teacher.

This reinforcement was achieved in this pilot investigation by using additional 'test questions' which required the students to give an explanation or reason for their particular answers. The underlying cause and extent of their confusion was then much more easily pinpointed. Further valuable information, regarding the diagnosis of EFs, was obtained in two ways. First from taking account of controlled student 'feedback' which was observed during the diagnostic test, and secondly from discussion of their errors with the students following preliminary EF diagnosis. However, retrospective analysis of the various diagnostic strategies which were employed suggests that there is often more merit in using a 'range' of different successive 'diagnostic tests' to deduce the fundamental or underlying EF in a given context, rather than using a procedure which relies on a single test made up from the same type of diagnostic questions.

It was proposed earlier that much can be gained, in terms of determining the overall structure of a learner's confusion by looking for a possible 'pattern' in the EFs which are diagnosed. The value of this strategy has been clearly demonstrated in this pilot study; such as in the analysis of students' errors concerning topic 1 where it enabled the true nature of their underlying EFs to be deduced. However, the tests of 'depth of understanding' which were subsequently employed to determine whether the students' confusion was a result of, for example, either under or over-generalisation on the part

of the teacher who taught the subject at a preliminary stage, were also found to be valuable. In addition, supplementary diagnostic 'test questions' devised for the confirmation of certain deductions regarding EFs, proved to be most useful. For instance, it was found that supplementary 'test questions' helped to confirm initial deductions about underlying EFs in the case of the erroneous answers given by some students to 'test questions' on topic 3. The supplementary 'test questions' employed in this particular instance were a combination of simple verbal reasoning and short written test questions which had been devised to show both the extent of the students' incomplete knowledge and the basis of their erroneous reasoning.

The 'elicitation technique' which was employed to confirm the preliminary diagnosis of students' EFs also proved to be a worthwhile strategy. Moreover, it was found that it subsequently saved both time and effort since it enabled the specific nature of the students' difficulties to be identified - then only the basic cause of their errors required to be corrected. It is felt that this is a far better strategy than the teacher merely guessing the nature, basis and extent of a learner's confusion; which the investigator has observed is often the case. Furthermore, it was found that an 'EF distribution and frequency' chart, such as that shown in Figure 17, was useful in enabling quick assessments or references to be made, regarding the number and relation of EFs in the various contexts described earlier. This also provided an important additional facility for the analysis of an individual student's error network. However, the use of 'network analysis' methods in this respect will be more fully investigated.

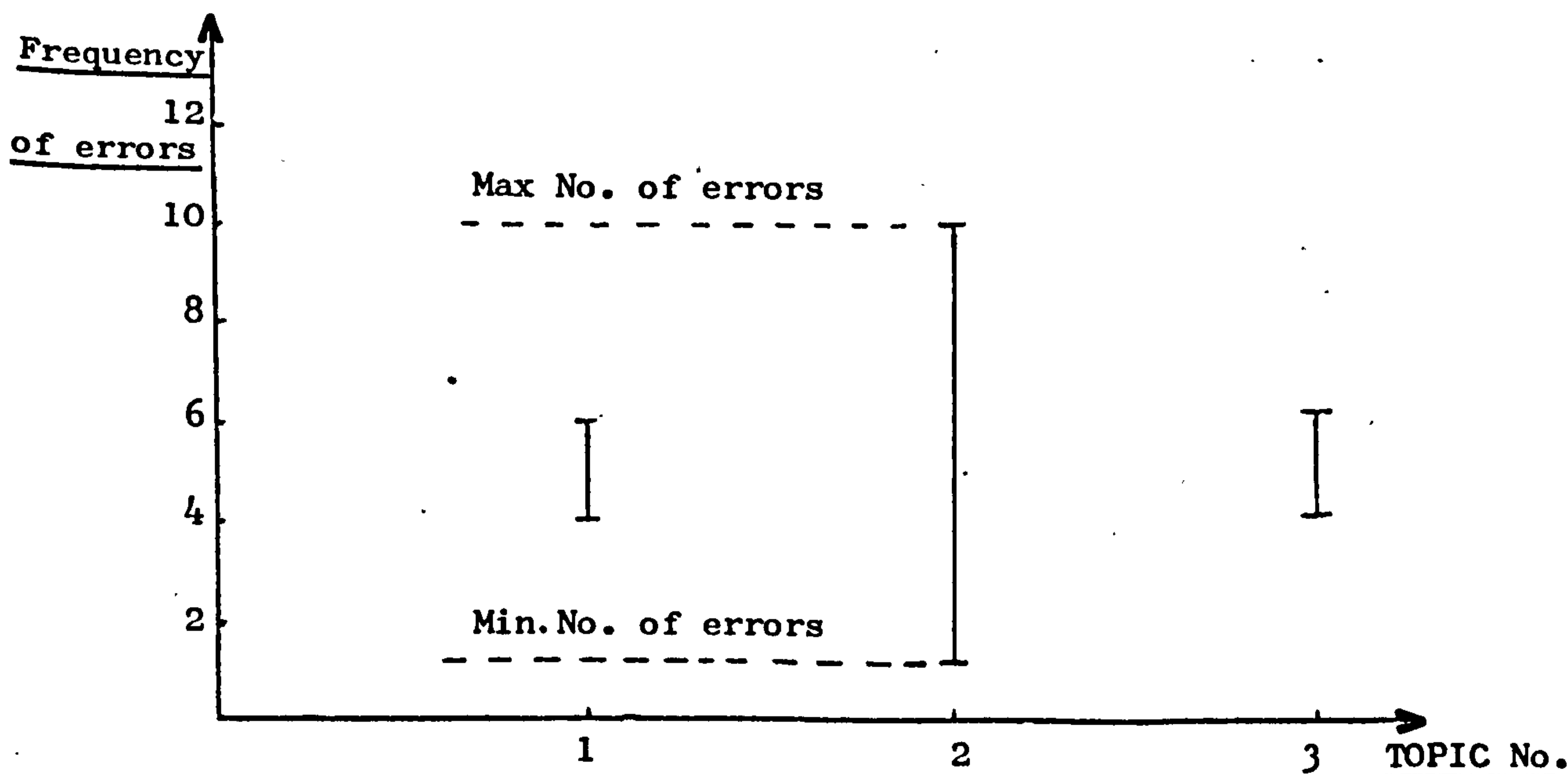

Error Distribution and Frequency

FIGURE 17

OBSERVATIONS REGARDING EF RECTIFICATION STRATEGIES

The principal method of EF rectification and removal which was employed with this group of 1st Year students was a simple technique of 'telling' them the true picture and discussing their confusion with them, so that they acquired a correct understanding in each case. However, it was sometimes found necessary to support these measures by simple demonstrations and/or student experiments. In view of the consequent results which were obtained, and the fact that this general EF rectification procedure was found to be both efficient and fast, it is considered that it is quite appropriate for this particular type of student group. Nevertheless, these EF rectification exercises were always double checked by giving the students further 'test questions', so that the effectiveness of the EF treatment was shown in practice and not left in doubt. The 'test questions' used for this purpose all required explanations so that the students had to demonstrate which were application and extent of their understanding. The observations which were made in this respect also reinforce the proposal that there is particular value in employing EF rectification procedures in such a way that a whole range of associated errors can be cleared up in the same process.

The background of several EFs which were identified in this investigation demonstrates the ways in which learning problems can be created by such things as poor planning by the teacher and lack of thought regarding the order of presenting what is to be learned (particularly in the earlier stages of learning or topic or subject). For these reasons care was taken regarding the order of rectifying EFs and so this was carried out according to the strategy for determining orders of correction described in the previous chapter. Learning difficulties were also observed which appear to have originated from poor flexibility on the part of the teacher in presenting explanations to the students. For example, this was thought to be the case with the EFs which were observed in association with topic 3, where certain inter-relationships were found not to be properly understood by many students. It was felt that this was because the various relationships had not been presented at the right time or in the appropriate context. Steps were thus taken in rectifying these EFs to ensure that this was done in a well structured way so that associated factors were taken into account and so that the students would not acquire too narrow an understanding of the topic. Furthermore, it was considered to be particularly important that EFs were not only completely rectified but that this was undertaken as soon as they were detected if possible.

It was intended to attempt to undertake EF rectification in as effective

and efficient a way as possible, within the limitations of the time available, and so decisions had to be made in several instances regarding whether this shall be done on a 'group' or 'individual' (or sub-group) basis. One way in which this was determined was to use a table (such as Table 3) in which the variations and relative numbers of errors were recorded for each topic. (Thus, for topic 2, it can be seen that some errors were common to a group and others were related to 1 student.) This table also revealed instances where there were common patterns of EFs on a given topic.

Error analysis table

Total number in group 17 students

(6 different diagnostic test questions given on each topic)

| <u>TOPIC NUMBER</u> | Total No. of errors for topic | No. of students making errors on topic | Variation in type of errors and proportion of students in each case |
|---------------------|-------------------------------|--|---|
| 1 | 60 | 10 | 6 : 4 6 : 4 |
| 2 | 66 | 11 | 10 : 1 10 : 1 |
| 3 | 60 | 10 | 6 : 4 6 : 4 |

TABLE 3

In this pilot study it was also intended to explore the hypotheses that EFs could be exploited to enhance learning and that students could learn from each other's errors. Hence, in cases such as topic 2, where the same type of confusion was found amongst 10 of the 17 students, the whole group of students underwent EF rectification treatment. This had the additional benefit that it would help to prevent the remaining 7 students falling into these pitfalls in future. In a similar way some 'useful EFs', which were identified in relation to topic 3, were employed in order to extend and develop the understanding of the students. Thus not only were the students' EFs rectified, but, more importantly, they were dealt with in such a way that the whole group learned from the exercise.

SUMMARY AND FURTHER CONCLUSIONS

The findings of this pilot experiment suggest that EFs in a given learning context can be detected and identified. Moreover, it was found that by using a range of diagnostic 'test questions' the EFs of individual students could be pinpointed. A variety of such 'test questions' were devised and their relative merits were explored, as was the employment of 'supplementary tests' and an 'elicitation strategy' to confirm the initial diagnosis so that the EFs could then be more reliably classified. An interesting observation in this respect is that there was a great similarity in the students' EFs which were identified for the various topics.

It is suspected that with previous groups of students many of the difficulties and learning problems which were diagnosed and subsequently rectified in this investigation had not been properly identified and that little attempt was made to resolve them. In order to explore this possibility the final physics examination papers of the 3 previous years students were examined and the results compared with those of the students in this study. Analysis of the findings, which are given in Appendix 4, suggests that there are grounds for concluding that previous groups of students experienced similar difficulties and made similar errors regarding the topics which have been investigated. This situation was subsequently discussed with the teachers concerned, and they were asked for their views on this problem. They all expressed the opinion that learning difficulties were to be expected owing to the complexity and nature of a topic such as current electricity, and also that it would require a great deal of time and effort to actually discover and rectify basic causes of students' misunderstandings. However, the findings of this pilot investigation suggests that this need not be the case. In fact, it could be found that more time would be available for teaching, since the employment of efficient strategies for treating EFs may actually save more time, overall, than they require of the teacher. Moreover, the situation could be further improved if the teachers used the information obtained from studying the students' EFs to improve the structuring of their teaching and made it sufficiently adaptive to deal with any additional difficulties which have not been observed in this preliminary investigation.

The rectification of EFs in this experiment was undertaken soon after they had been identified and several months before the students took their final examinations. Reference to their results in this examination, which are shown in Appendix 4, (p.204), indicates that the benefits obtained from EF rectification measures had persisted. However, their results for the topics which had not been subjected to any EF treatments were much poorer, and more

in keeping with those of students in the previous years who had undertaken this course.

In an attempt to replicate these findings it was decided to undertake a second pilot study using several groups of students and a different setting. As can be seen from Table 4, a significant number of students in each group made errors in this follow-up experiment. This table is only presented here to illustrate the large number of errors which were detected and the similar pattern of errors observed for each topic. (More details are given in Appendix 5).

EF PROFILE: Follow-up Pilot Experiment.

Subject: Radioactivity. (Student responses to diagnostic 'test questions')

| Number of students in group | Topic 1: No. of students making errors | Topic 2: No. of students making errors | Topic 3: No. of students making errors |
|-----------------------------|--|--|--|
| Group 'A' 10 | 7 | 7 | 7 |
| Group 'B' 10 | 6 | 6 | 6 |
| Group 'C' 15 | 9 | 9 | 8 |
| Total Number of students 35 | 22 | 22 | 21 |

TABLE 4

The main details of the design of the more comprehensive follow up pilot experiment are as follows. It was undertaken in a wider physics context, and two parallel matched groups each of 10 students were studied, in order that the preliminary findings could be more thoroughly tested. One group was randomly designated as the 'control' group and the other as the 'experimental' group. Furthermore, so that the applicability of the particular EF diagnosis and rectification measures that were devised for this topic could be more fully explored, a second 'experimental' group was included in the investigation (the latter being a group of students who were undertaking a different course, but who were studying the same physics topics as the other two groups). The various EF treatments or measures which were investigated and the results of the experiment are summarized in Appendix 5. However, it should be reported that the findings and empirical evidence reinforce those obtained in the preliminary investigation. Moreover, some new evidence and fresh observations regarding the nature of EFs was also obtained. This subsequently proved to be of great value in formulating strategies for EF treatment as part of the major experimental investigation which will next be reported.

CHAPTER 4

A MAJOR EXPERIMENTAL INVESTIGATION OF THE ROLE OF EFs IN TEACHING

INTRODUCTION

The knowledge and experience which was obtained from the preliminary studies meant that the investigation could progress to the stage where a major experiment, involving a detailed practical investigation and assessment of the role of EFs in teaching, could be undertaken. However, it was intended that this exercise should also provide the opportunity for the implementation of new or amended strategies for treating EFs in the classroom. The earlier investigations, 'protocols' and pilot studies had already provided valuable 'field trials' for these strategies and supplied important preliminary evidence. On the basis of these findings, it was decided that the students and teachers, who were specially selected for this experimental investigation, would be studied over a whole academic year. It was also decided that a special monitor and 'log' would be employed to ensure that all relevant evidence was observed and recorded. Furthermore, various 'iterative procedures' and elicitation techniques were specially formulated to enable a full assessment of the role of EFs to be attained. Certain 'contingency measures' for EF treatment, which were developed in earlier experiments, were employed as the need arose. An examination of possible EFPs, including teachers, text books, badly designed student attainment tests, and poor learning environments, was also undertaken. Finally, the strategy of teaching 'thinking', and the 'open classroom' technique suggested by Gilbert (op.cit.), were both adopted and their influence on reducing the incidence of 'undesirable EFs' subsequently analysed.

SUMMARY OF MAIN OBJECTIVES

A fundamental objective was that the investigation would lead to the identification of new facets of the behaviour or properties of EFs and provide fresh evidence or insights which would help to extend present knowledge of their nature. Moreover, as appropriate, these findings were taken into account in suggesting certain modifications to EF theory, which will be discussed later in this chapter. A further aim was that appropriate evidence and empirical data would be obtained which could subsequently be assessed with regard to identifying any necessary improvements in the special EF treatment frameworks and the 'procedural' schemes devised for EF rectification which were being investigated. Later in the investigation it was intended that a careful

examination would be made of the evidence and observations with a view to designing improved strategies for exploiting the potential of EFs for accelerating or enhancing learning in the classroom.

It was also hoped that some of the findings in this investigation would help to reinforce certain theoretical predictions, which were presented in earlier chapters, regarding the properties and types of EFs (while in other cases the findings may negate these). Nevertheless, in either circumstance it was intended that this detailed study would help to reveal and clarify particular areas or aspects which would profit from further investigation in future. Hence, it was not intended either to formulate or employ a rigid framework for EF treatment, since this could prove to be too restrictive, but instead to adopt a rather 'open-ended' approach in this respect. Similarly, the intention was that the diagnosis of errors and confusion would be undertaken in the sense proposed by Polya (1974) which is, in his words:

"a closer characterization of the students' work".

This is because it is felt that the teacher needs a close characterization of the learner's confusion if he is to rectify it more effectively. Furthermore, it was decided to explore various means of predicting EFs in a given learning situation and examine the effectiveness of these measures.

Another major objective of this investigation was to examine the use of 'algorithms' for aiding learning and for EF prevention. With this aim in mind a special algorithm was devised for this purpose and employed at an appropriate stage of the experiment. It was intended that this algorithm would help to save the students both time and effort. However, the main function of the algorithm which was devised and employed in this experiment was that suggested by Landa (op.cit.).

"..... If the student is taught these operations in the framework of an algorithm, then he masters the correct method of solution and the correct way of reasoning and acting relatively easily and quickly"

The effectiveness of this and other EF prevention measures which were explored will be assessed in greater depth in the final chapter, when detailed appraisal of the entire investigation will be presented. Moreover, although the experiment was undertaken in the context of a physical science subject the relevant evidence and discoveries will be analysed in such a way that possible implications for teaching in other contexts are revealed. Finally, general conclusions will be drawn regarding the future modification or adaptation of the various EF treatment techniques employed in the experiment.

BASIC DESIGN OF EXPERIMENT

The investigation was designed within the overall guidelines obtained from the pilot studies but on a more protracted time scale with more comprehensive coverage and aims. Although there have been no other major investigations in this context which could have provided assistance in formulating the experiment, it was known what empirical data was being sought and the main objectives of the experiment had also been identified. For reasons which will be more fully explained later, it was decided to undertake the EF investigation in 3 related stages extending over an entire academic year. This would mean that certain EFs could be treated at appropriate stages, then the effectiveness of the measures monitored and modified treatment provided if required.

Three matched groups of parallel 1st Year students studying physics were selected for the investigation. They were all given pre-tests at the start of the course and their progress assessed by appropriate post-tests. In addition, at the end of the year all students undertook a common physics examination. Two of the groups ('A' and 'B') were taught by the investigator (of these group 'A' was randomly designated the 'experimental' group, and the other acted as the 'control group'). Group 'C' which acted as a further 'control' group was taught by a different lecturer. Details of the structuring of the teaching and the physics course will be given at a later stage. All three groups spent the same amount of time studying physics and were given the same facilities for learning, but the 'experimental' group had a special 'framework' of EF treatment measures provided for them. This flexible 'framework' embraced EF prediction, detection, diagnosis and rectification measures. Strategies for reducing the frequency of 'undesirable EFs' and for exploiting 'useful EFs' to enhance learning were also included. Furthermore, both the analysis of student 'feedback' on learning difficulties and a 'brainstorming' technique were employed with the experimental group in order to obtain a clearer understanding of their EFs. The whole experiment was carefully monitored by an independent observer, and a weekly 'log' of observations relating to the EF measures was kept so that a more complete picture of the investigation was obtained.

SPECIAL PRECAUTIONS

As an experimental precaution, and in order to achieve some basis of true comparison for the purpose of subsequent validation, the special techniques for EF detection, diagnosis, rectification and so on were employed without the students' prior knowledge. It was felt that, within reasonable limits, this

special investigation would remain unknown by the students involved and in practice this did prove to be the case. Similarly, the lecturer who was teaching the third group was not told the exact nature of the special measures which were being employed with the experimental group. He was asked to teach his group in the same way which he had taught previous groups and to report their progress to the investigator. As a reliability check the tests and final examination papers for all three groups were marked by the investigator and double marked by the other lecturer.

CHOICE OF SUBJECTS AND SETTING

The investigation was undertaken in a modern British polytechnic using three comparable groups of 1st Year students each group being made up of 12 students. (Evidence obtained from the pilot studies suggests that this size of group would be most suitable for a detailed examination of EFs to be undertaken.) The particular physics course selected for the investigation is typical of similar courses provided in other polytechnics and is one which the investigator had previous experience in teaching (as had the other lecturer involved in the experiment). Evidence obtained from 'entry tests' and other sources indicated that the students taking the course were of comparable age, overall ability, previous experience and general background. Moreover, the students in each of the groups were typical of students who had undertaken the course in the past. It was intended to compare the students' attainment at the end of the course and a further reason why these particular groups were chosen was that there were particularly comprehensive assessment facilities available for their course.

STUDENT DATA

The following details are a summary of the relevant data concerning the three groups of students. Other details will be given in the text as appropriate.

| | | |
|----------------------------|---|---|
| Average age: | : | 18 years |
| Total number in each group | : | 12 students |
| Physics background | : | ONC/OND Technology or 'A' level Physics |
| Main course of study | : | HND Technology Engineering |
| Stage of study | : | 1st year (of 3 years) |

| | | |
|------------------|---|--|
| Lesson Structure | : | One period of $2\frac{1}{2}$ hours per week (with 15 minutes break after $1\frac{1}{4}$ hours) |
| Area of study | : | Physics, electronics |
| Topics of study | : | Phase relationships and frequency |

CHOICE OF TOPICS

In choosing the learning topics and tasks to be investigated there were several important objectives to be satisfied. The first of these objectives was that the learning tasks chosen should be sufficiently typical so that the results of the investigation would provide an extensive, but true and meaningful picture of the role of EFs in teaching. Furthermore the actual subject matter of the learning task must be one which did not involve too wide a range or level of topics, or one in which these were too narrow. A further requirement was that each stage of the learning should not be too protracted (special steps were taken to avoid any learning problems arising due to poor recall or similar effects, and, when subsequent discussions about the origins of their errors took place with the students, these factors were taken into account). It was also considered that the learning topics which were particularly suitable for this investigation were those requiring both practical and theoretical 'learning' to be undertaken by the student. However, the actual learning tasks selected must be realistic ones, because of the present limitations due to the lack of other detailed evidence concerning EFs. Moreover, the tasks and topics which were chosen must allow for a certain amount of deviation and re-arrangement - which may prove necessary once the experiment was actually underway. For these reasons, the subject matter chosen was physics and the particular topics of study will shortly be described in detail, along with further reasons for their choice.

GENERAL REMARKS CONCERNING THE EXPERIMENT

The specific subject matter of the learning topics and tasks will be referred to in detail only in cases where this has actual bearing on the investigation. Similarly, much of the routine teaching data, instructions and demonstrations which were provided by the teachers will be condensed and described in general terms only. Hence, in this way, the various aims and objectives described earlier should be more readily achieved and more clearly assessed in the final analysis. It is intended that the general conclusions

which will later be presented will not just be specific to the particular groups of students and the learning tasks selected for this study. Moreover, these conclusions will have a valid basis in a real learning situation and they will not be founded upon hypothetical evidence. An attempt will also be made to crystallize both the merits and flaws of the strategies or techniques used for the treatment of EFs during the course of the investigation.

Various statistical methods of evaluation were employed to account for the anticipated variations in the learners' responses to the diagnostic and attainment tests. Furthermore, it should be pointed out that care was taken to ensure that any modifications in the EF treatment system, which the findings at various stages of the experiment indicated were necessary, maintained the basic element of flexibility which was described earlier. Hence, in this way it is hoped that the modified strategies could still be projected into different learning situations in future investigations.

OUTLINE OF BASIC EF TREATMENT CRITERIA

This was made up of two eight point strategies, one of which was for the teacher and the other was applied to the students.

1. Summary of General Teaching Criteria

(Not necessarily in order of priority)

1. Use a flexible, 'open ended' instruction technique.(To allow for EF treatment as the need arises). Structure teaching situation and 'order' learning tasks. (This was done along the lines advocated in earlier chapters). Encourage students to 'think' about their learning tasks. Keep a 'teaching log' to monitor learning and EF treatment.
2. Carry out exercises for EF prediction and prevention of 'dangerous EFs' since electrical equipment is involved (e.g. by use of 'algorithms' and by informing students of the hazards and providing them with preventative measures.) Use a 'yardstick of correctness' to deal with any errors of judgment made by the students.
3. Employ EF prediction 'profile' to pinpoint and avoid 'undesirable' EFs . Prevent or rectify these by 'telling'

students of them and by employment of an 'iterative' technique.

4. Employ EF diagnostic strategy on 'broad' front initially, then 'converge' on specific causes of confusion, using simple 'supplementary' test questions and 'elicitation' technique (as described in the previous chapter) prior to undertaking classification of complex EFs. Also encourage discussion, questioning and 'feedback' amongst the students.
5. Be ready to follow up and 'exploit' EFs as they arise (or when opportunity for maximum learning benefit is available). Also use 'teachback' to help clear up misunderstandings. Use special technique (described in Chapter 3) to determine best order of EF removal.
6. Promote and exploit 'useful EFs' during teaching (especially if a whole cluster of errors can be corrected in the same exercise). Use EF correction to aid motivation when possible.
7. Adopt a 'guided discovery' type of practical approach (with appropriate follow up) especially to rectify EFs encountered in practical work and student experiments. (This was done in an 'open classroom' environment, as shown in Plate 2).
8. Employ frequent checks to avoid tacit acknowledgement of EFs and possibility of generating EFs. Be ready to modify teaching and EF treatment accordingly. Look out for 'partial' misunderstandings when examining students' work.

2. Summary of General Criteria for Students

(Not necessarily in order of priority)

1. See that there is a feeling of general freedom and lack of fear amongst the students - so they will say if they are confused or misunderstand something.
2. Provide students with reasonable time/facilities to either 'follow through' and learn from their errors, or to have them removed using EF rectification techniques, as

appropriate. (By using the 'open classroom' technique the laboratory was converted into a set of 'learning centres' in which they worked out the set objectives and progressed to learn from their errors).

3. Give student aid and experience to enable him to discover that he is using inappropriate problem solving techniques etc. Encourage use of 'teachback' amongst students to identify/rectify EFs.
4. Make provision of reference data to assist student in 'guided discovery'. Also provide appropriate yardsticks to help student sense that he is going wrong. Give information about EFs so learners can anticipate certain pitfalls and thus avoid them.
5. Encourage 'error awareness' (i.e. knowledge that there are many EFs in the particular context and they are not alone in making errors) see that 'motivation' is not adversely affected if student encounters many EFs.
6. See that students have clear details of what they are expected to learn, what they should know, and the tasks which they are expected to perform at end of learning sequence. (This is to give the student a yardstick by which to judge his own performance). Provide 'test questions' which are free from ambiguity. Inform student of possible EFPs in the particular context (e.g. badly written text books, poor instructions and so on).
7. Provide student with rules and guidance for avoiding or rectifying errors due to carelessness, accidental mistakes or misinterpretation; make it clear that these are not EFs in the context of learning.
8. Give student a clear understaining that he can learn and profit by his errors - and those of his peers so that he attempts to do this and is not daunted by his errors. Help student to classify and diagnose his own EFs - but check this.

**TEXT BOUND INTO
THE SPINE**



PLATE 2

MAIN DETAILS OF LEARNING TOPICS

Three related physics topics were specially chosen for the investigation since they embraced both practical and theoretical skills or understanding . The first topic selected for this purpose was one which also involved the use of mathematics. This included the determination of 'frequency' and 'phase relationships' using the technique of 'Lissajous figures' (this required the employment of certain electronic apparatus in a number of student practical experiments). The second associated topic was one that required the learner to extend his knowledge and understanding of 'phase' and 'frequency', and to learn how to correctly interpret 'Lissajous figures'. The final topic was one which demanded both practical skill and understanding in using oscilloscopes, signal generators, and various other electronic apparatus to produce various Lissajous figures. Further details of the specific learning topics will be given, as necessary, later in the chapter.

Further Remarks on the Learning Tasks

It was realised that a certain amount of basic prior knowledge and skill was required for the students to carry out the various tasks which were specified. Thus, some provision was made to ensure that the students obtained this prior learning and skill. They were all tested to confirm that they had acquired this before the experiment commenced, and measures were taken to resolve any remaining difficulties.

SUMMARY OF EF PREDICTION MEASURES

EF Prediction 'Profile':

This is a summary of the anticipated EFs, learning problems and difficulties (some of which were identified in the 'entry tests').

- (i) All the students will have previously been taught about 'phase' (past experience of such students suggested that they may be confused about its actual interpretation in terms of 'phase relationships' and 'phase changes'). Therefore, if this anticipated misunderstanding was identified it could be used to clear up a whole area of confusion concerning 'phase' and phase properties. (i.e.

it could be a source of 'useful EFs').

- (ii) Experience of previous students suggested that some confusion could arise with regard to 'phase diagrams' and phase changes (especially those displayed on the oscilloscope). Some students may not even have seen such a display on an oscilloscope. Guidance was thus given in this respect in order to (a) prevent and/or (b) 'exploit' these predicted EFs to reinforce understanding of 'phase diagrams'. Hence, 'entry test' questions were designed to identify this condition.
- (iii) It was anticipated that confusion may arise regarding the interpretation of 'Lissajous figures' and when using them for determining an 'unknown' frequency. These 'useful EFs' could be employed to illustrate the properties of 'Lissajous figures' and help to establish their use for frequency determination. ('Teachback' could be employed to good effect in this context.)
- (iv) Certain 'undesirable EFs' were anticipated in the use of the oscilloscope etc. (due to inadequate skill and misunderstanding by the student). These must be avoided or quickly cleared up. A special 'information sheet' and an 'algorithm' were designed to deal with this situation.
- (v) Experience of previous groups of students suggested that certain difficulties may arise in the calculation of frequency (due to students' misunderstanding frequency ratios). This could be used to help to precipitate and rectify confusion about all such frequency ratios.
- (vi) Various minor difficulties and misunderstandings concerning the setting up of the various electronics apparatus were considered to quite possible. These could be employed to reinforce and clarify certain properties and applications of the electronic apparatus used.
- (vii) It was anticipated that misconceptions regarding the use and application of certain electronic circuits could result in errors and electrical hazards. (Special preventative measures were devised for dealing with this possibility.)

GENERAL EF PREDICTIONS

There were a number of minor practical and theoretical EFs anticipated which have not been specifically referred to in the 'profile' given earlier. Nevertheless, as was discovered in the pilot studies, these must be taken into account as their effects could become more significant. Thus, the previous list is really a summation of the major areas of possible EFs rather than a complete indication of specific EFs. In addition to these EFs it was also anticipated that some errors could arise due to misinterpretation, incorrect working, and so on, which could not be readily predicted and so these were dealt with as they arose. Hence, decisions regarding the action to be taken were made on their identification (the measures used were based on the teacher criteria previously enunciated). Care was taken concerning unpredicted 'useful EFs' so that their rectification was undertaken with the joint aims of enhancing learning and efficiently clearing up all associated errors. However, in the actual teaching situation, it was found contingencies of this type could be minimised, as will later be explained.

Since there could be a large number of different EFs in a given learning situation the EF prediction scheme also contained measures to account for both EF rectification priorities and the exploitation of 'useful EFs' (but not to the exclusion of permitting any incidental 'useful EFs' being exploited to aid learning as the occasion arose). Furthermore, a balance was struck regarding the use of predicted EFs and what it was expected the student should be helped to learn without the aid of EFs. Similarly, between the accommodation of only those predicted EFs thought 'desirable' for the objective of efficient learning and the prevention of other possible EFs in the particular learning context. In other respects the general EF prediction measures which were employed for this investigation were based on those used in the second pilot study.

SUMMARY OF EF DIAGNOSTIC STRATEGIES EMPLOYED

The EF diagnostic 'format' which was employed in this experiment was devised on the basis of the experience gained from the pilot experiments. This framework, which is shown in Figure 18 was made up of several successive stages so that the subsequent detection and classification of EFs would be more specific. As can be seen, special supplementary 'test questions', and the 'elicitation technique' (which was discussed earlier) were employed after the main diagnostic measures had been carried out, in order to confirm the final diagnosis of the underlying EF.

BASIC DIAGNOSTIC FRAMEWORK

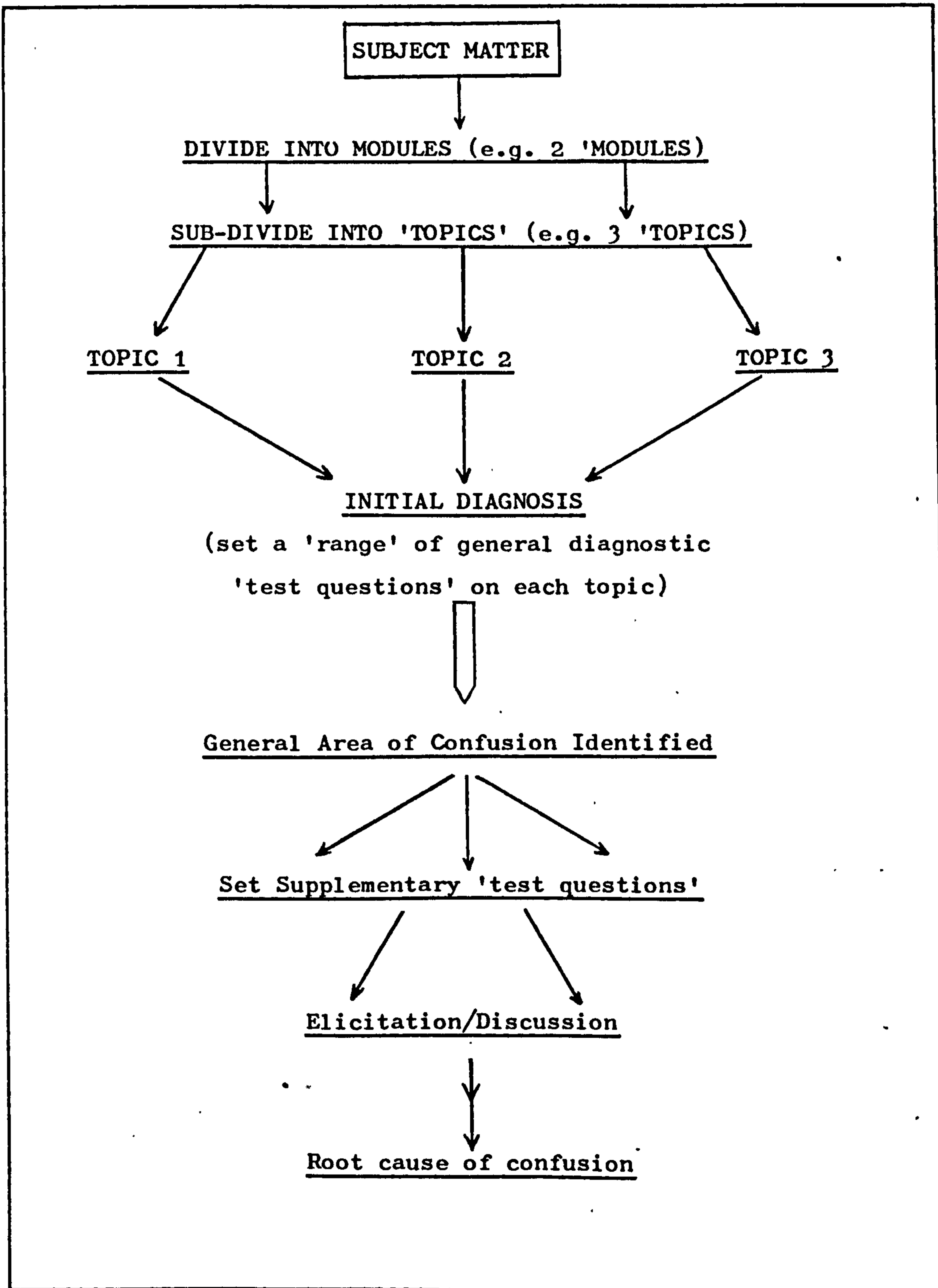

FIGURE 18

In addition to the main diagnostic strategy and certain contingency measures which were mentioned earlier, a special 'cause and effect' scheme was also used when necessary (see Fig. 19 for outline of this). Hence, various paradigms of EF diagnosis and classification strategies were embodied within the overall diagnostic framework. As necessary, particular reference will be made, at appropriate stages, to both the detailed '8 point' teacher criteria and learner criteria that were employed in the EF scheme. Furthermore, in order to indicate some of the differences between the special EF diagnostic techniques and the normal teaching procedures used with this type of group, each of these approaches will be briefly described in the initial parts of the descriptions of the three stages of the investigation.

Certain statistical measures were employed at appropriate stages of the EF diagnostic treatment, including the provision of large numbers of diagnostic 'test questions' (to enable the effects of 'random variations' or 'systematic effects' to be accounted for). Moreover, a 'chi square' test was employed in the analysis of the simple 'supplementary' test questions. In order to account for possible 'guessing' in the 'multiple choice' objective type 'test questions' the following equation was employed:

| | | | |
|---|---|-----------------------|--|
| Score corrected for guessing = $TR - \frac{TW}{NA-1}$ | | | |
| TR | - | total right answers | |
| TW | - | total wrong answers | |
| NA | - | number of distractors | |

DIAGNOSTIC FRAMEWORK

The structuring of the EF diagnostic 'framework' was based upon the strategies which were described earlier. This involved the dividing of the subject matter into modules of 'associated' learning topics, and these were then sub-divided into 'analytical' topics each of which was finally divided into learning stages. (e.g. 'Lissajous figures', 'frequency determination' and so on). Each of these topics was then initially examined on a 'broad' front, using a wide range of different types of diagnostic 'test questions'. Several examples of these, which were used in the pilot study, were presented in the previous chapter. Various 'open-ended' type 'test questions' were also employed in order to reveal the extent of possible confusion, and other

'test questions' were formulated to check the presence of the various predicted or anticipated EFs. Finally, in order to converge on specific causes of confusion, special 'supplementary' diagnostic measures were employed. These were formulated along the lines discussed earlier and were based upon the experience obtained from the follow-up pilot experiment. The electronic 'feedback classroom' system was used to enable the rapid testing of the whole group of students to be done simultaneously, and to reveal 'patterns' of confusion.

Example of format for basic EF Diagnosis Chart

| Effects | | Possible Causes | | |
|-------------------------------|---|---------------------------------|-------------------|----------|
| GROUP EFFECTS | INDIVIDUAL EFFECTS (OR PREDICTED EFFECTS ¹) | GROUP CAUSES | INDIVIDUAL CAUSES | BASIC EF |
| Listed according to frequency | | Listed according to probability | | |

FIGURE 19

GROUP EFFECTS - when group of students make similar errors (this is then narrowed down to specific errors made by individuals)

¹ To be employed when not all individual effects are known but are predicted.

THE EXPERIMENT

DIAGNOSTIC STAGE

TOPIC 1: Theory of 'Lissajous figures'

Method 'A' (without special provision for EFs)

General Teaching Plan (Summary)

Provide an explanation that the 'Lissajous figure' is the locus of the resultant displacement of a point on which two simple periodic motions are impressed. Demonstrate that these two periodic motions are at right angles, and thus a trace of these on an oscilloscope is one of a series of ellipses which correspond to the possible differences in phase between the two motions. Illustrate these explanations and provide relevant problems or examples.

N.B. This explanation was supported by a series of phase diagrams and examples. See Figures 24 and 25 (p.146).

Method 'B' (with special provision for EF diagnosis)

General Teaching Plan (Summary)

This teaching plan embraced all the teacher and learner criteria which were described in detail in an earlier section. Furthermore, the teaching was preceded by an 'entry test' to give a basic picture of the students' understanding.

Provide an explanation as in method 'A' but with special reference to factors such as the fact that there may be more than two simple harmonic motions - (hence checking the extent and range of possible misunderstanding of this topic). This was then followed by 'test questions' and student discussion concerning 'phase'. This was carried out according to points (i) and (ii) and (iii), which were previously described in the EF prediction 'profile'. It was also carried out in order to confirm or identify other

(Method 'A' was used with both the 'control' groups and 'B' with the 'experimental' group.)

EFs in this context which had not been predicted. All the other EFs observed during this stage were treated using the strategies contained in the diagnostic 'framework' which was summarized earlier.

The general explanation was supported by diagrams and examples as for method 'A' (but with the additional special measures which were advocated in the section concerning teaching criteria and techniques). The diagnostic measures which were employed included the following types of 'test questions' to diagnose any general confusion with regard to the understanding of 'phase'. However, to identify the specific causes of confusion the special measures explained earlier were adopted.

SAMPLE DIAGNOSTIC 'TEST QUESTIONS': TOPIC 1

Sample 'Test Question' (type 1)

'Write down what you think the term 'phase' means and give an outline of what you know about it'.

Objectives

This type of 'test question' was intended to reveal both the main area of confusion and the limits of understanding on this topic (N.B. Subsequent rectification of this limitation should also clear up or prevent a number of potential EFs).

Sample Test Question (type 2)

'Say which of the two cases 'A' and 'B' shown below illustrates an 'out of phase' relationship'.

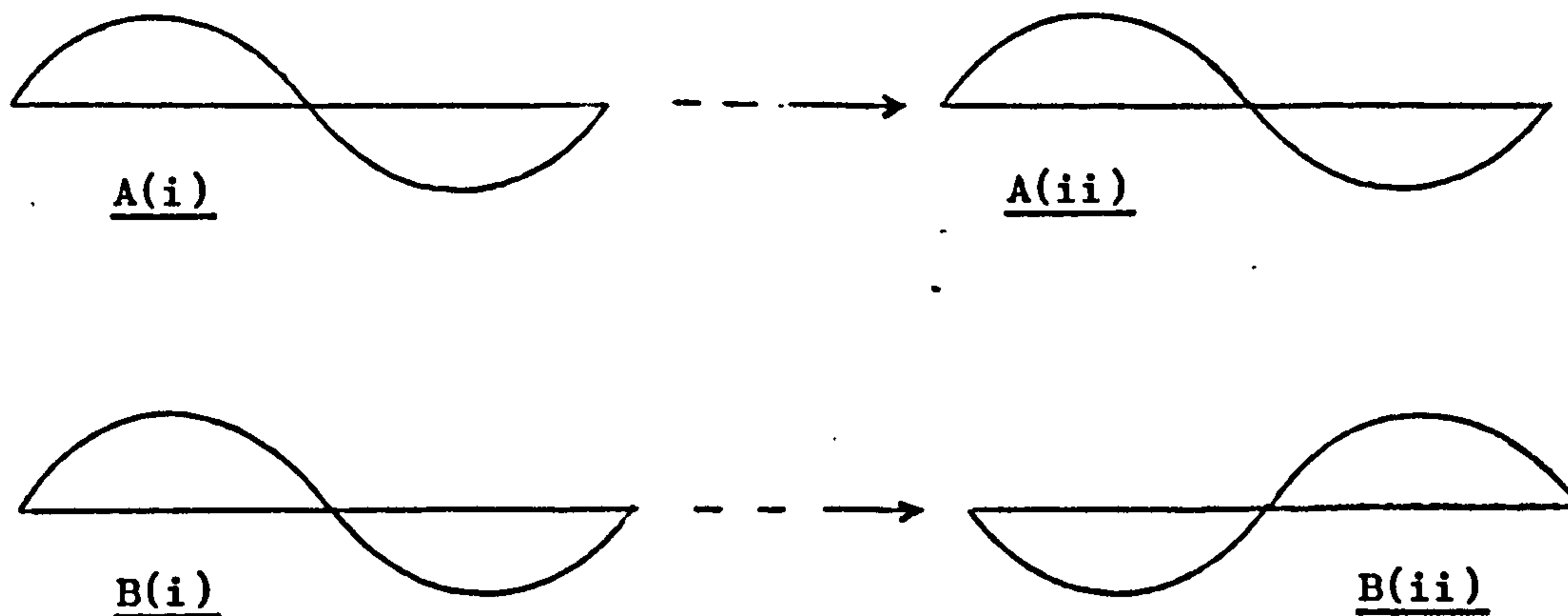

FIGURE 20

Objectives

The objectives of this type of 'test question' were to reveal general difficulties in the comprehension and 'visualising' of 'phase relationships'. Also to discover if the student could correctly illustrate this visualisation with the aid of a 'phase diagram'.

Sample 'Test Question' (type 3)

'Is the following statement correct? Give reasons for your answer. Why is the term 'exactly' specified in the conditions?'

'The points in the path of a wave motion are said to be points of equal phase if the displacements at those points at any instant are exactly similar'.

Objectives

This form of 'test question' was devised to help to reveal gaps in the students' understanding of 'phase'. Since it is 'open ended' it would also assist in the detection of general misconceptions and EFs in this context.

Typical EF analysis results

'Diagnostic 'test question' results (Objective type test)

Responses of students in Group 'A' to a 10 item test

| Question Number | S T U D E N T S | | | | | | | | | | | | No. Correct | P |
|-----------------|-----------------|----|-----|----|----|----|-----|---|----|-----|----|----|-------------|------|
| | A | B | C | D | E | F | G | H | I | J | K | L | | |
| 1 | | | i | | | | i | | | i | | | 9 | 0.75 |
| 2 | | iv | | iv | | | | n | | | iv | | 8 | 0.65 |
| 3 | | | | | | | | | | | | | 12 | 1.00 |
| 4 | | i | iii | i | | | iii | | | iii | i | | 6 | 0.50 |
| 5 | | | | | | | | | | | | | 12 | 1.00 |
| 6 | | | | | | | | | | | | | 12 | 1.00 |
| 7 | | iv | ii | iv | | | ii | | | ii | iv | | 6 | 0.50 |
| 8 | | | | | | | | | | | | | 12 | 1.00 |
| 9 | | | iii | | ii | | iii | | | iii | | | 8 | 0.66 |
| 10 | | | | | | | | | | | | | 12 | 1.00 |
| Score | 10 | 7 | 6 | 7 | 9 | 10 | 6 | 9 | 10 | 6 | 7 | 10 | | |

TABLE 5

Each of the 12 students in the group was designated a different letter of the alphabet. The first student was known as student 'A' and so on. In the above table Roman numerals indicate the number of the incorrect distractor; a blank indicates that a correct distractor was given by the student; 'n' - no response. Reference to Table 5 shows that there were two common groups of errors for items 4 and 7. A pattern of distinct errors is shown for students B, D, K and a second pattern (corresponding to a possibly different underlying EF) for students C, G, J.

Calculation of test scores

1. Correction of scores to account for possible guessing was carried out according to the formula described on page 127

$$(i.e. S = TR - \frac{TW}{NA-1})$$

There were 4 distractors for each multiple choice objective test question.

2. Correction of scores to account for omission of answers to 'test questions' was carried according to the formula:

$$\text{Corrected score } S = TR - \frac{NO}{N}$$

NO - number of questions omitted
 N - Number of questions
 TR - Total number of right answers

Corrected scores: for Table 5

| STUDENT | A | B | C | D | E | F | G | H | I | J | K | L |
|-----------------|----|------|------|------|------|----|------|-----|----|------|------|----|
| SCORE | 10 | 7 | 6 | 7 | 9 | 10 | 6 | 9 | 10 | 6 | 7 | 10 |
| CORRECTED SCORE | 10 | 6.00 | 4.67 | 6.00 | 8.67 | 10 | 4.67 | 8.9 | 10 | 4.67 | 6.00 | 10 |

These corrected scores reinforce the possible pattern of common EFs observed for students B, D, K and a different common pattern of EFs for students C, G, J. (See Table 5)

Sample 'Supplementary' Test Question (TOPIC 1)

(Used in conjunction with electronic 'feedback classroom').

According to the principle of 'Lissajous figures' to obtain an elliptical trace on an oscilloscope screen there must be:-

- A. 45° phase difference
- B. 90° phase difference
- C. No phase difference
- D. 180° phase difference

Objectives

These 'supplementary' test questions were designed to confirm the basis of the general confusion concerning 'phase', which were revealed by the 'first order' type diagnostic 'test questions'. Correct answers to the 'test questions' on this topic would show that the student understood 'phase differences' (but possibly does not understand 'phase relationships' - so further 'supplementary' test questions were needed to diagnose this). Wrong answers to questions on this aspect would indicate basic confusion resulting from misunderstanding 'phase differences'. (This was confirmed by further 'test questions', the elicitation technique, and discussions with the students.)

Typical EF analysis results

Supplementary diagnostic 'test question' results
corresponding to Table 5 results

(True/False Type)

Responses of students in group 'A' to a 10 item test

| Question Number | S T U D E N T S | | | | | | | | | | | | No. Correct | P | |
|-----------------|-----------------|---|---|---|----|----|---|----|----|---|---|----|-------------|----|------|
| | A | B | C | D | E | F | G | H | I | J | K | L | | | |
| 1 | | | | | | | | | | | | | | 12 | 1.00 |
| 2 | | | ✓ | | | | ✓ | | | ✓ | | | | 9 | 0.75 |
| 3 | | | ✓ | | | | ✓ | | | ✓ | | | | 9 | 0.75 |
| 4 | | | | | | | | | | | | | | 12 | 1.00 |
| 5 | | ✓ | ✓ | ✓ | | | ✓ | | | ✓ | ✓ | | | 6 | 0.5 |
| 6 | | | | | | | | | | | | | | 12 | 1.00 |
| 7 | | ✓ | | ✓ | | | | | | | | ✓ | | 9 | 0.75 |
| 8 | | ✓ | ✓ | ✓ | | | ✓ | | | ✓ | ✓ | | | 6 | 0.5 |
| 9 | | | | | | | | | | | | | | 12 | 1.00 |
| 10 | | | | | | | | | | | | | | 12 | 1.00 |
| Score | 10 | 7 | 6 | 7 | 10 | 10 | 6 | 10 | 10 | 6 | 7 | 10 | | | |

TABLE 6

DIAGNOSTIC STAGE

TOPIC 2: The application of 'Lissajous figures' and use for frequency determination.

Method 'A' (without special provision for EFs)

General Teaching Plan (Summary)

Give students an explanation to provide them with an understanding of the application of 'Lissajous figures' and to determine its unknown frequencies (also assist in the promotion of their ability in using this understanding). These explanations were illustrated by diagrams and supported by practical examples of various 'Lissajous figures' with 'known' and 'unknown' frequencies. Later the students were asked to apply the techniques they had learned to calculate various unknown frequencies themselves.

Method 'B' (with special provision for EF diagnosis)

General Teaching Plan (Summary)

After first setting and analysing the results of an 'entry test' the basic approach and explanations employed were the same as those used in method 'A'. However, in order to identify possible EFs, the following additional measures were undertaken. (These were intended to complement the special diagnostic measures and 'teaching criteria' described earlier). The measures included the examination of joint practical and theoretical skills. Furthermore, special 'test questions' were set relating to 'frequency' in general (to pinpoint any 'systematic' errors). To encourage student 'feedback' these questions were partly oral and were based on practical demonstrations of 'Lissajous figures'. Some of these oral and written type 'test questions' are illustrated by the following typical examples.

Some sample diagnostic 'test questions'

Sample 'Test Question' (type 4)

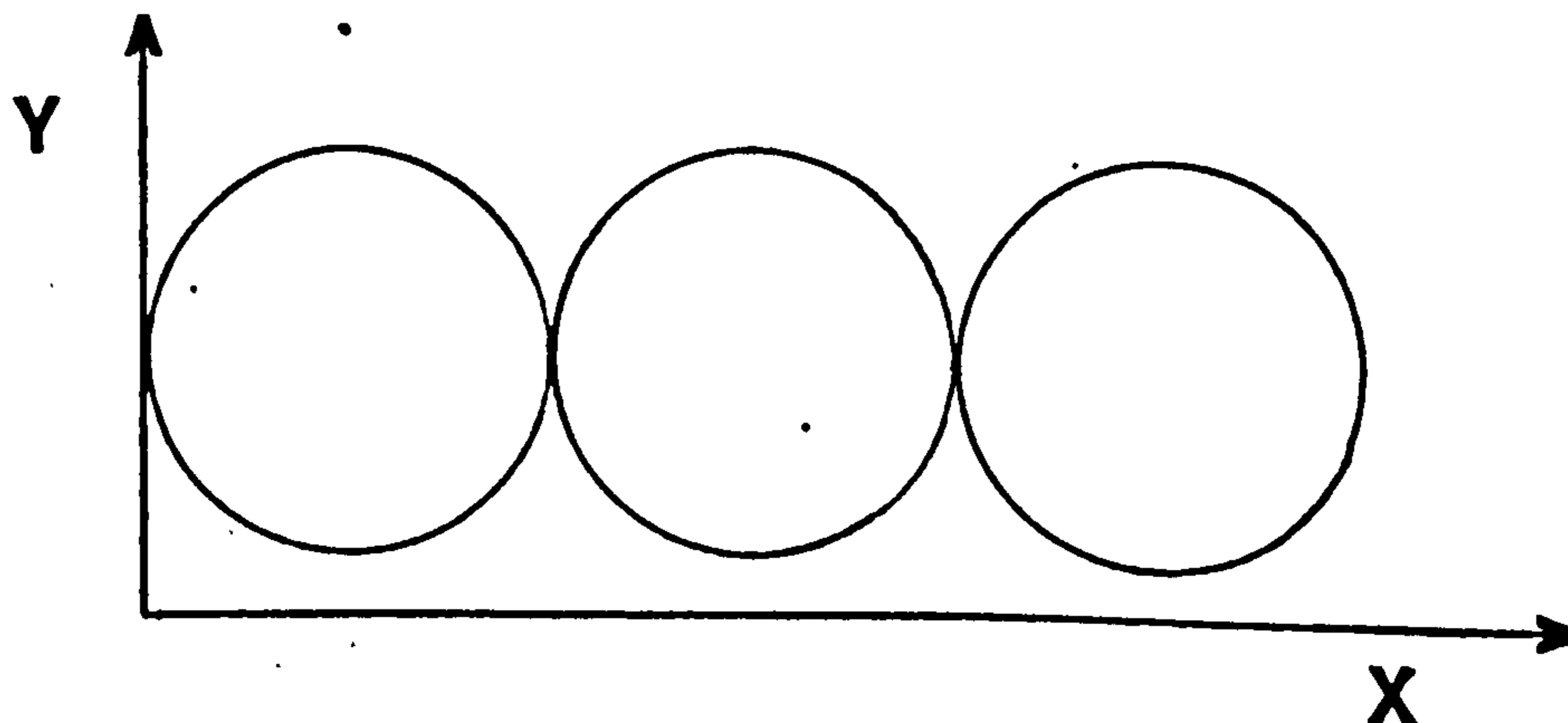

FIGURE 21

Questions

'In the Figure (see Figure 21) the frequency applied to the 'y' plates of the oscilloscope to produce this Lissajous display is 500 Hz. What would be the frequency applied to the 'x' plates? If this same frequency was also applied to the 'x' plates? If this same frequency was also applied to the 'y' plates what shape of Lissajous trace would be seen on the oscilloscope screen'?

Objectives

The aim of the first part of this type of 'test question' was merely to test the students' ability to interpret the theory of 'Lissajous figures'. This would also assist in the discovery of general confusion in this respect. In the second part of this type of 'test question' the object was to assess the student in terms of his depth of understanding. These questions were also intended to reveal the possible results of the transfer of earlier misunderstandings concerning frequency ratios. Students having no real 'depth' of understanding, which was mentioned in the EF prediction profile, were also identified by these 'test questions'.

Sample 'Test Question' (type 5)

FIGURE 21

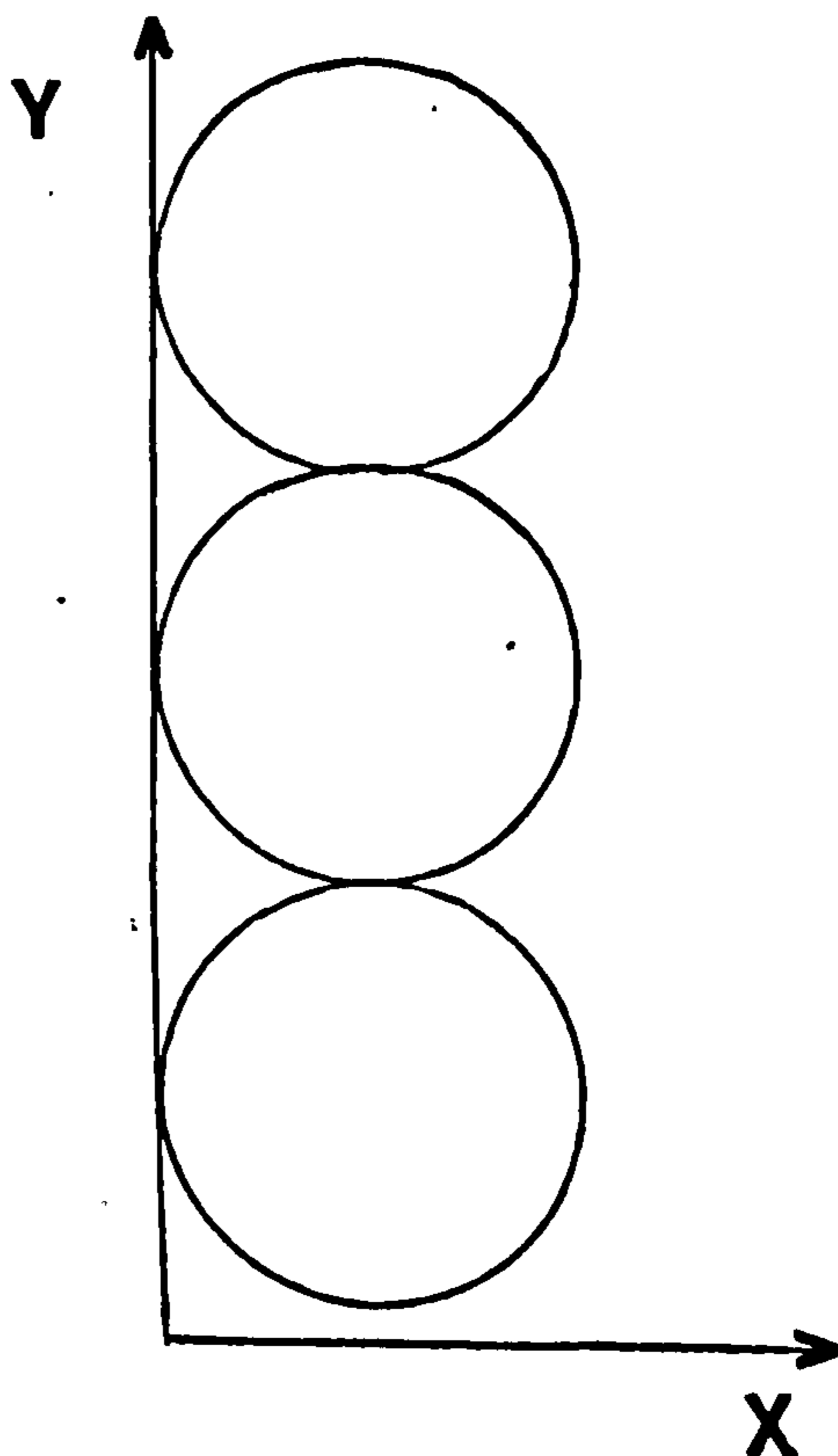
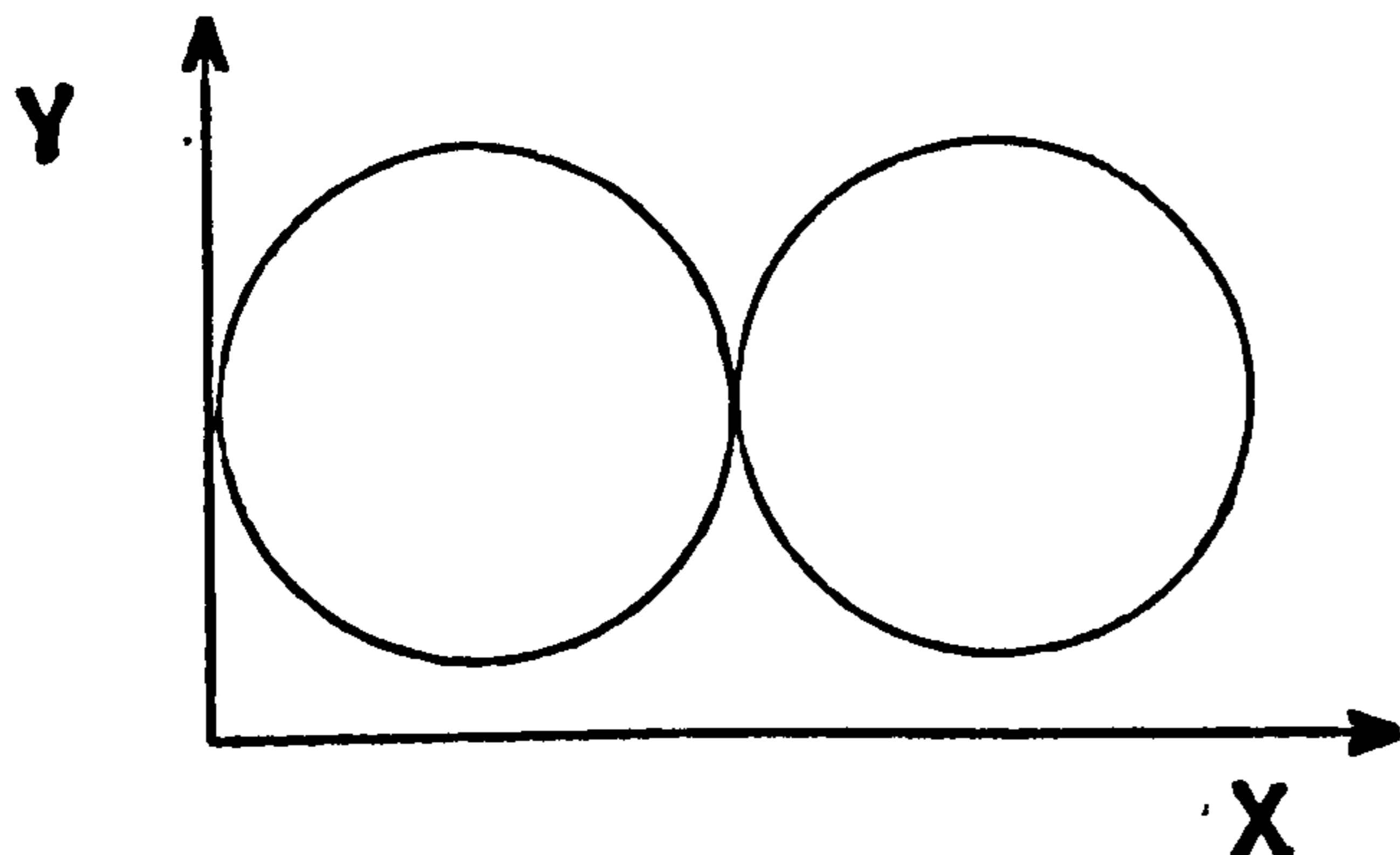

FIGURE 22

Questions

'If the equation for the frequency ratios for the 'Lissajous figure' shown in the left hand figure (see Figure 21) is $f_y = 2f_x$ (where f_y and f_x are the 'y' and 'x' displacement frequencies respectively), what equation describes the trace for the other figure? (see Figure 22). Give reasons for the 'form' of equation you produce.

Objectives

The main objective of this type of 'test question' is the determination of general misunderstanding concerning phase and frequency relationships. This evidence was also found to be of help in confirming the presence of possible EFs which it had been anticipated could arise from general confusion regarding 'frequency' and 'frequency ratios'. Other EFs which had not been anticipated were generally revealed by the 'open-ended' nature of this type of diagnostic 'test question' (see the last part of this sample 'test question').

DIAGNOSTIC STAGE

TOPIC 3: Experimental techniques and use of electronic apparatus for 'Lissajous figures' production.

Special Measures

The third topic required the students to have a prior understanding of certain principles and skills in the use of (a) oscilloscopes and (b) 'signal generators'. In the past it was normally assumed that the students did have this necessary understanding and skill. However, the 'entry test' results showed that there could not be complete certainty that all the students had this understanding. Therefore, in the case of the group of students who were having special EF measures applied, the following special precautions were employed to account for this possibility. Another aim of employing these measures was to avoid certain possible 'undesirable EFs', which were explained earlier, and to make use of certain other 'useful EFs' to aid and improve learning success. A special instruction/error identification system

was designed for this purpose. This was backed up by the provision of an appropriate 'algorithm'. The latter was employed when the students were actually using the oscilloscopes. Comments and observations will later be made regarding certain minor modifications which were found necessary in these special measures.

General Teaching Plan (Summary)

A practical approach was employed, and initially all the students were told the theory and shown the principles of the various electronic apparatus necessary to produce 'Lissajous figures'. The students in the 'control group' and the group who are being taught by the other lecturer were treated likewise. However, the latter two groups were taught without the use of the special EF prevention measures, which were as follows:

Special EF prevention measures

TOPIC 3 'a' Use of Oscilloscopes

Special strategy and instructions given to students in 'experimental' group, including informing them about possible 'undesirable EFs', and using these EFs to reinforce the need for their avoidance.

Student instructions (Oscilloscope)

Summary of main points

1. After having checked that the oscilloscope has the 'brilliance' control turned to minimum (students were told reasons for this* and effect of certain errors in this case) and that the apparatus is plugged into the mains supply, it may then be switched 'on'.

2. The 'Time Base' control must be switched 'off' so that the spot or trace on the screen can be focused. (Students were told why this was necessary and the difficulties which would result from their not doing this).

3. When using the oscilloscope check the type and polarity of the inputs. (Again students were informed of consequences of errors in this respect - with the object of reinforcing understanding of oscilloscope use and functioning).

* Particular stress was given here to avoid damage to oscilloscope screen.

Special Algorithm

(for use by students when operating oscilloscope)

The special algorithm (see Figure 23) was devised on the basis of one which had been formulated by Lewis (op.cit.). It was introduced to support or clarify the operation of the oscilloscope and prevent certain EFs. It was not just designed for EF avoidance, but also to show the student possible faults or errors with the operation of the oscilloscope (along with their effects and correction). Therefore, this algorithm contained a diagnostic element - which was also intended to extend the students' knowledge of various 'causes and effects' when they encountered faults or errors in operating the oscilloscope. It would also give them experience in dealing with the effects of such errors.

TOPIC 3 'b' Use of Signal Generator

The following is a special strategy and set of instructions which were given to students to identify possible anticipated errors (or other general misunderstandings) in the use of this apparatus - and to rectify the EFs causing these. However, the individual student's EFs were sometimes found to need individual diagnosis - followed by appropriate rectification as the

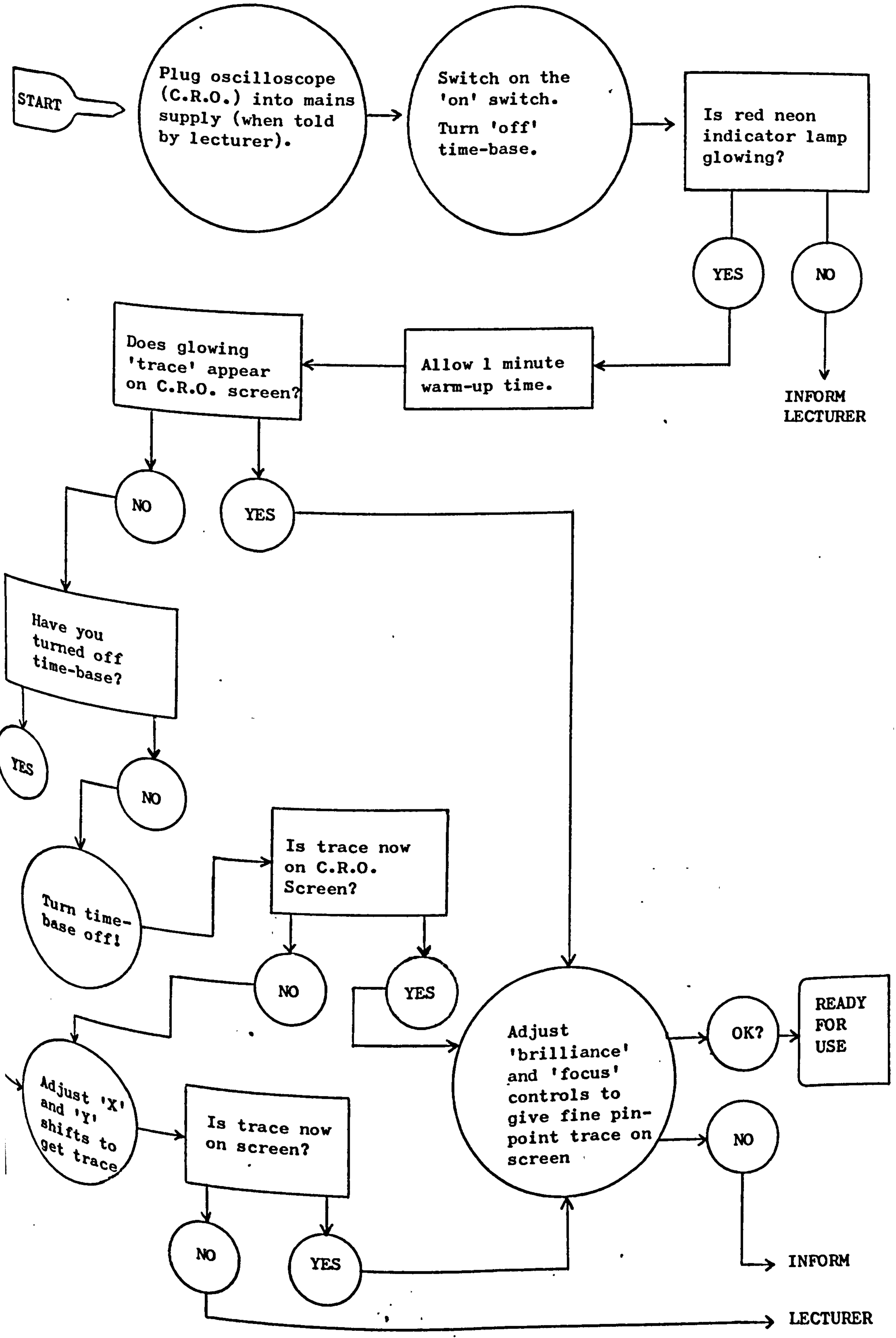

FIGURE 23

particular EFs were identified.

Student Instructions (Signal Generator)

Summary of main points

1. After having plugged signal generator into the mains supply and switched 'on' (a red pilot light should be illuminated to show it is working*). Allow at least three minutes for the apparatus to warm up. (This precaution and its consequences were employed to reinforce understanding of the functioning of the signal generator and also certain other electronic apparatus i.e. to develop 'transfer' of understanding). Then set the output to about 12 volts. (*Inform lecturer if this does not happen).
2. Check that the output voltage does not fluctuate during the course of your experiment and adjust this if necessary. (The 'causes and effects' of this were used to give useful emphasis of this condition, and reduce the chances of future errors or confusion in this respect).
3. Ensure that (for this experiment) the output is set for 'sine wave', using the output control switch at the bottom right hand corner of the signal generator. (The results of failure to do this could be exploited to correct any misunderstanding about different waveforms. This could also help to pinpoint gaps in students' understanding of signal generator output properties).

N.B. Owing to the students' previous experience in using the signal generator, and its relatively simple operation an, algorithm for its operation was considered unnecessary (with this particular group of students at least).

Student Practical Experiments

As explained earlier, specific details of the actual practical experiments which the students carried out will not be given, unless these are felt to be important in the context of this investigation. Nevertheless, it should be stated that the various diagnostic measures for dealing with EFs which were previously illustrated were employed in the rest of this stage too. Again, these measures were undertaken within the diagnostic framework which was previously explained in detail, and the various 'teacher criteria' enunciated earlier were also accounted for at this stage. In addition, the students had their experimental work 'monitored' using the diagnostic equipment shown in Plate 3. During the course of monitoring the student could be 'fed' spurious information to test his understanding and ability to overcome confusion.

Further comments on EF strategies

It should be emphasised that, in keeping with the criteria and objectives specified earlier, a 'guided discovery' approach was pursued with the experimental group, and particular emphasis was placed on 'student experiments' throughout Stage III. For example, after having successfully set up the final 'Lissajous figures' experiment, the students were asked to see, using the same apparatus, what they could 'discover' about such things as 'frequency relationships', 'Lissajous figures', and 'phase properties'. They were also required to comment on their discoveries and to try to explain them. This was done with a view to discovering any misconceptions or difficulties which had not been predicted and to help in identifying EFs which had not been positively identified by the various diagnostic measures previously undertaken.

The exploitation of EFs in this final stage and in the earlier stages of the experiment will be discussed in detail later. Nevertheless, it should be noted at this point that no students in the 'experimental' group (i.e. the group receiving special EF treatments and measures) made any actual errors or expressed any difficulties when finally carrying out the experiments on this topic. However, with regard to the other groups seven out of twelve

**TEXT BOUND INTO
THE SPINE**

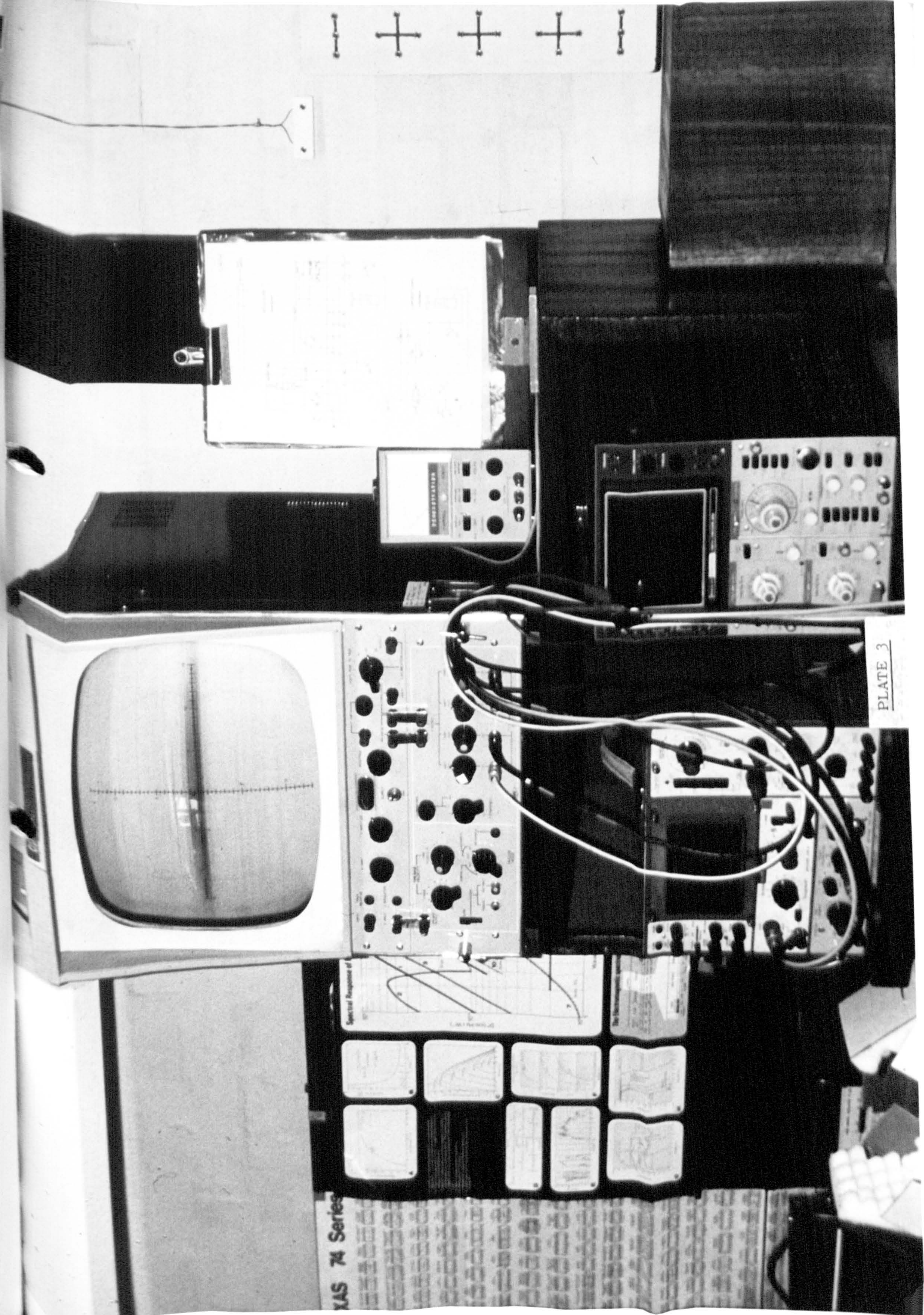

XAS 74 Series

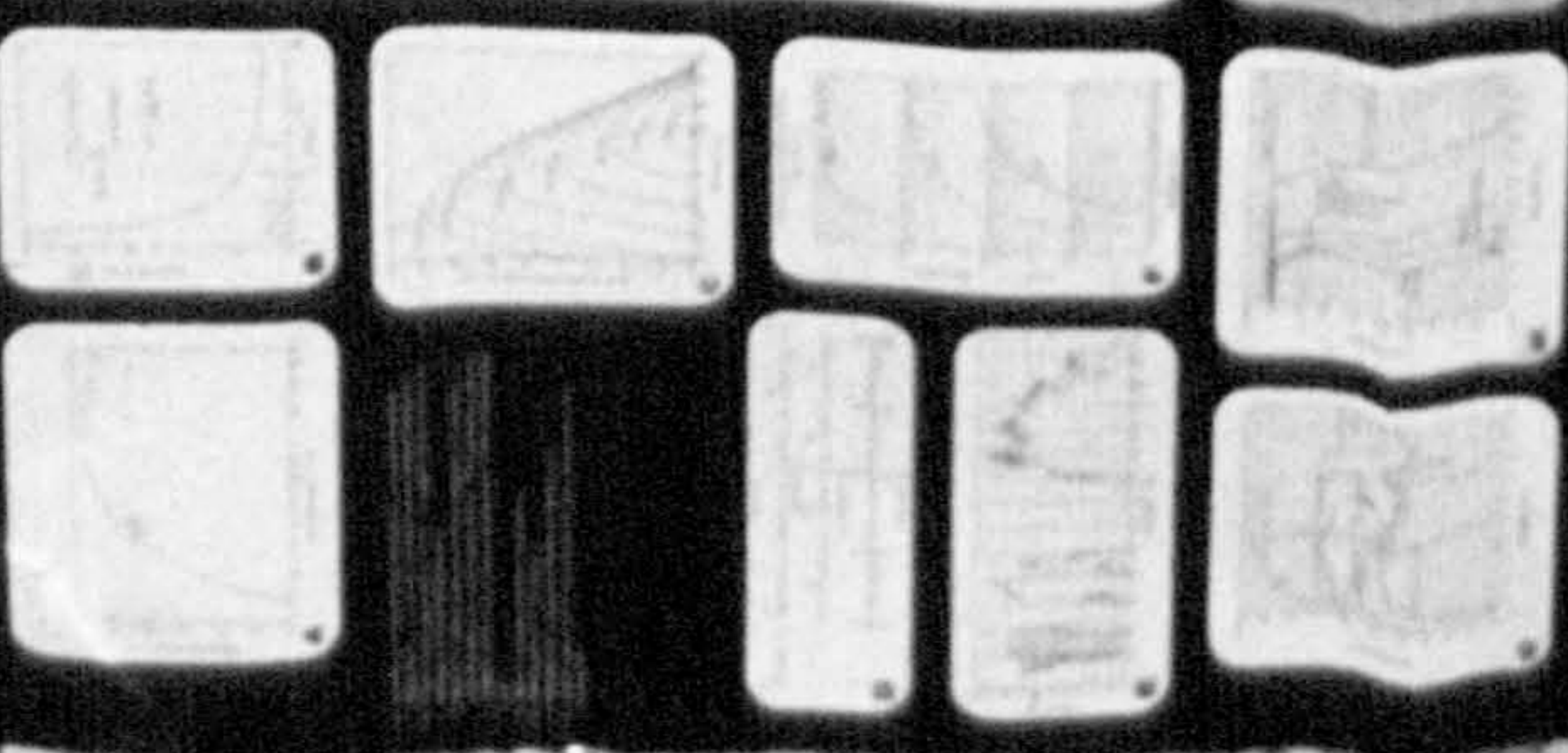
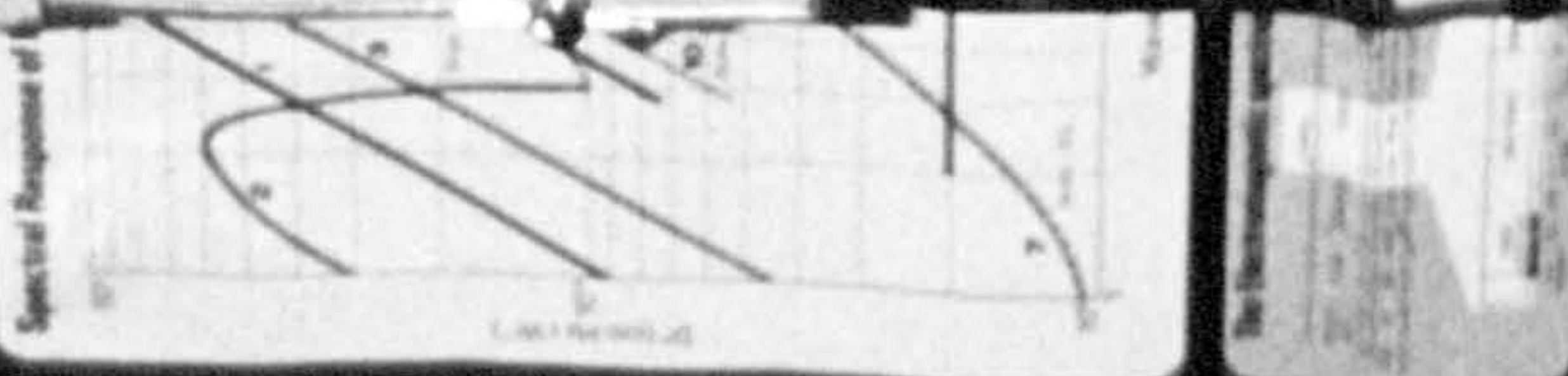

PLATE 3

students in group 'B' and 8 in group 'C' made various errors and were clearly confused about the topic. Perhaps the greater awareness of possible errors and misunderstandings, resulting from the employment of special EF measures and the provision of the algorithm for Part 1 of the student experiment, contributed to the superior results which were obtained with group (A).

Modifications to EF treatment strategies

A few minor modifications and changes to the EF diagnostic strategies were found necessary during the course of the investigation. Various observations and comments on these changes, which were recorded at the time, will be given in the 'Teaching Log' in a later section of this chapter. Of the various modifications and changes felt necessary, following the practical trials of the diagnostic measures, few were considered to be absolutely essential.

DISCUSSION OF RESULTS

EF PREDICTION STRATEGY

The EF prediction strategy and the EF 'profiles' were found to be simple in use but effective when employed in the actual teaching situation. With reference to the EF diagnosis results, shown in Table 6 (p.135), it was found that all the general EFs which had been predicted occurred and were successfully identified by the special diagnostic measures and 'test questions' on each of the three topics which were described earlier. In addition, other 'significant' EFs which had not been anticipated and accounted for, were identified by these tests. Some EFs were subsequently identified because of the 'open-ended' nature of certain types of diagnostic 'test questions' which were used (such as type (5) 'test questions'). Certain linked EFs and 'patterns' of confusion, similar in nature to those observed in the pilot studies, were also identified in the investigation (as shown in Table 7). Various conclusions will later be drawn regarding the significance of these discoveries and findings concerning EF prediction.

EF DIAGNOSTIC STRATEGY

The EF detection results shown in Tables 7 (p.147) and 8 (p.151) only apply to what are effectively 'major' EFs. However, in each of the

PHASE RELATIONSHIPS

(These figures were presented to all 3 groups)

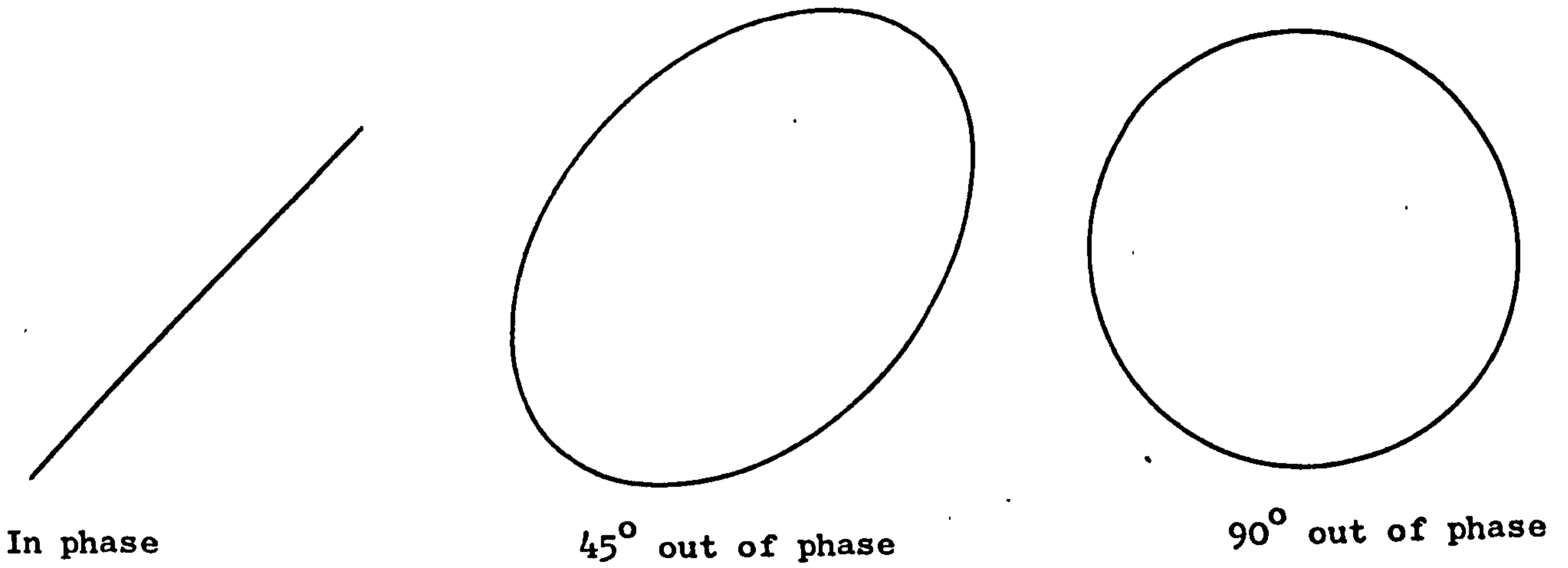
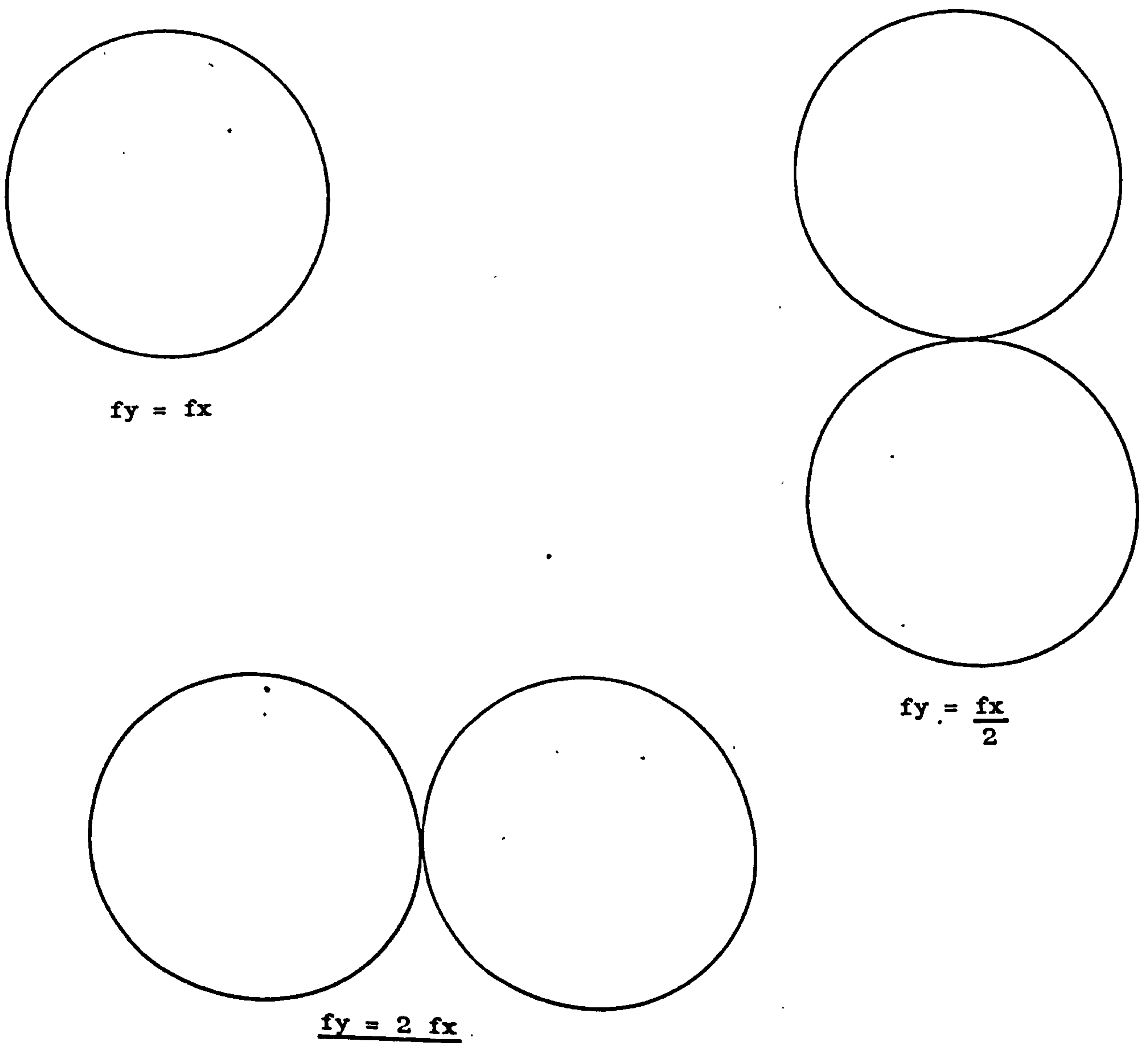

FIGURE 24



f_x , f_y -frequency applied to x and y plates of oscilloscope respectively.

FIGURE 25

diagnostic stages certain 'minor' EFs were also detected and subsequently diagnosed. The latter EFs varied considerably both in type and frequency of occurrence. The initial analysis of this evidence indicated that on the whole, these 'minor' EFs were not of any great significance, either individually or in terms of their overall effect on learning. Thus, it was considered that they did not merit a special diagnostic scheme being devised to deal with them, and they certainly did not require one on the same scale as that formulated for diagnosing and predicting 'major' EFs. Nevertheless, a number of these 'minor' EFs were dealt with remedially as they were identified. This remedial exercise was carried out by employing the general procedure for EF rectification which was described in the previous chapter.

N.B. extracts from the 'Teaching Log' (which was written during the teaching of all the stages of the investigation) will be presented later, since they reveal some interesting observations and findings concerning the diagnostic strategy employed in this experiment.

Error Analysis: Group 'A' students

| <u>TOPIC</u> | Number of students in whole group making predicted errors | |
|--------------|---|--|
| Topic 1 | Total 6 | (Predicted errors) |
| Topic 2 | Total 5 | (Predicted errors plus 2 different errors) |
| Topic 3 (a) | Total 3 | All made <u>same</u> error (predicted) |
| Topic 3 (b) | Total 3 | All made <u>same</u> error (predicted) |

TABLE 7

EF PREVENTION MEASURES

Some comments have already been made concerning the fact that no errors were made by any of the students in group 'A' when using either the oscilloscope or the 'signal generator' to carry out their experimental investigation of 'Lissajous figures'. However, it was observed that a number of students in groups 'B' and 'C' (who did not have the special EF avoidance procedures and treatments provided for them) did make a number of errors in this context. This evidence confirms the earlier conclusion that special EF preventative measures can be effective and are worthwhile in such contexts. The findings also suggest that the measures which were devised for this purpose could be used with different groups of students.

No significant modifications were considered necessary to either the special EF prevention scheme or the algorithm which was devised for this investigation. Nevertheless, as will later be explained, it was thought that if the scheme was made more adaptable it could be possible to employ it in other learning contexts. For instance, a 'Whif diagram'¹ could perhaps be devised in such a way that it could be incorporated in the general EF prevention system for dealing with the use of other types of apparatus. (This basic 'Whif diagram' could be readily modified for use with different students or equipment). The employment of a 'Whif diagram' could also be of further value for EF prevention since it may be used to indicate to the student the possible effects of his errors - in terms of when and if certain errors occur.

CLASSIFICATION OF EFs

TOPIC 1

Reference to Table 7 reveals that 6 of the 12 students in group 'A' showed certain confusion regarding 'phase relationships' (which was predicted and subsequently identified by some of the 'test questions' that were presented on topic 1). More detailed analysis of the erroneous answers of these 6 students to the 'test questions' and of their comments in respect to verbal 'supplementary' questions, clearly indicated that they had too 'narrow' an understanding of both 'phase' and 'phase relationships'. All these 6 students displayed the same confusion, although there was some variation in the effects of this which were observed. These EFs could be broadly classified, according to the system described in the previous chapter, as 'fundamental' EFs (possibly originating from limited breadth of understanding). However, following more detailed diagnosis, involving the use

1 A 'backward - chaining' scheme using 'when' and 'if' instructions.

of 'supplementary' test questions and the employment of the 'elicitation technique' it was found that there were actually two different EFs involved.

As will be seen from reference to Table 8, of the 6 students who made errors regarding Topic 1 it was discovered that there were 4 students whose confusion and errors were of a similar nature. The basis of this common confusion was eventually found to be a consequence of their inability to understand and solve certain problems. This confusion was found to be due to difficulties in the transfer of understanding from one type of problem to new problems. Thus, these EFs could be classified as 'limited transfer' EFs. Diagnostic 'test questions' of type (4) were found to be helpful in revealing the basis of this particular type of EF, as was the use of 'brainstorming' with the students involved. It was considered that in this case an attempt to sub-classify this EF was not necessary, since it is only a question of degree of transfer involved, not type of transfer. Suggestions will be made later concerning the rectification and exploitation of this particular class of EFs - both to improve breadth of understanding and to clear up all associated 'learning transfer' difficulties.

It was subsequently found, after more specific EF diagnosis had been undertaken, that the other 2 students, who made errors on this topic both made the same type of error. A careful assessment and examination of these errors, reinforced by evidence obtained using the 'elicitation technique', revealed that these errors were the result of a limited depth of understanding of 'Lissajous figures' and frequency. These EFs would therefore be classified, according to the general classification scheme, as 'depth limitation' EFs. Reference to the 'teaching log' reveals that the 'open ended' diagnostic 'test questions' of type (5) were quite helpful in the diagnosis of this situation.

TOPIC 2

It can be seen from Table 8 that there were 5 students who made errors with respect to Topic 2. Some of these errors were only revealed by the special diagnostic 'test questions', and had not been anticipated. However, of these 5 students 1 student was subsequently discovered to have made errors due to 'carelessness' in working out his answers and equations for 'test questions' of type (4) and (5). Of the other 4 students, 3 were discovered to have made similar errors. These errors were later found, after using the 'supplementary' test questions and other diagnostic measures, to be the result of basic confusion about 'frequency ratios' and also about phase differences. Their EFs could be generally classified as 'systematic' EFs.

This is because their misunderstandings were eventually found to be the consequence of the type of system that had been used in teaching these topics in their earlier learning.

The fifth student who had made errors concerning Topic 2 was subsequently found to have made errors because he did not fully understand the relationships between 'phase' and 'frequency'. Hence, this EF could be classed as a 'fundamental' type EF, also arising from too narrow an understanding of the topic. However, this particular EF was later exploited to remove all his confusion and limitations in this context.

TOPIC 3

It was discovered that 3 of the 12 students in group 'A' displayed confusion and made errors which had not been specifically anticipated in the EF prediction 'profile'. However, the employment of the special diagnostic measures, which were previously outlined, led to the detection and subsequent identification of their EFs. The 3 students' errors in this context were all of the same basic form. It was eventually found that these arose because of their inability to interpret the results of 'Lissajous figures' experiments. Furthermore, this inability was found to stem from basic confusion as to what the results which they obtained actually referred to. An EF of this nature would be classified, according to the scheme described in Chapter 3, as a 'partial understanding' EF. This is obviously an EF which must also be specifically accounted for when modifying the scheme for EF diagnosis in any future investigations.

SEE TABLE 8 OVERLEAF

EF Analysis: Group 'A'

| Topic | Total Number of students making errors | Number of students making different errors |
|---------|--|--|
| Topic 1 | 6 | $\frac{4}{4} + \frac{2}{2}$ (4 made <u>same</u> errors) + (2 made <u>same</u> errors) |
| Topic 2 | 5 | $\frac{1^*}{1} + \frac{3}{3} + \frac{1}{1}$ (3 made <u>same</u> errors) |
| Topic 3 | 3 | All 3 made <u>same</u> errors |

* errors due to carelessness in arithmetic: not due to EFs

TABLE 8

GENERAL COMMENTS ON THE EF DIAGNOSTIC STRATEGY

Now that specific proposals and suggestions have been made it may be helpful to comment on the EF diagnostic strategy in general. For example, it should be noted that, during the teaching of group 'A' students (who had been randomly selected for the special EF treatment) an attempt was made to identify and classify their EFs as they arose. This task was undertaken using the special diagnostic strategies advocated earlier. However, it was found that the identification attempts made during the actual teaching of these students was not easy, and also complex EFs had eventually to be dealt with at later stages in several instances. Perhaps the chief reason for this was lack of immediate and detailed information concerning the nature of certain difficulties or misunderstandings and the fact that a certain amount of time was required to analyse the information. Therefore it is not advocated that major EF identification and analysis should generally be undertaken during teaching in the classroom. Especially since this was found on one particular occasion (fortunately not with serious consequences in terms of producing further confusion) to lead to an incorrect EF diagnosis being made.

It was decided to carry out the EF classifications in broad divisions only, so that the overall classification scheme could be more clearly assessed. A significant problem which was encountered in this respect was that, on three separate occasions, there were students who had made errors (which had been preliminarily diagnosed) that were absent during the following lesson-and so the EF diagnostic measures got out of step. Means must therefore be found of dealing with this problem, if the teacher has frequent cases of student absenteeism. The various EFs which would be classed as 'useful' EFs, that were predicted in this investigation, were checked off as they were identified and used to clear up certain areas of anticipated confusion. This requirement meant that the EFs had to be 'grouped' and dealt with as appropriate at the time - which was not always very convenient and was missed by students who were absent.

Other desirable or 'useful' EFs, which had not been anticipated, were added to this check list as and when they were identified (and also used to enhance learning where possible). However, this exercise was undertaken with care, since it was considered unwise to attempt either quantitative or qualitative analysis of EFs, except to a limited extent, during actual teaching. Care was also taken to identify and report all errors which were observed at every stage for each topic. This was done so that fuller evidence could be obtained about the nature and behaviour of EFs and to limit carry-over of EFs to new topics.

FURTHER COMMENTS ON EF RECTIFICATION

As was explained, various EFs had been predicted for each topic, and after these had been detected and identified they were rectified according to a predetermined plan of action. Certain other EFs, which had not been specifically anticipated, were also rectified according to this scheme. It should be pointed out that the scheme, which was devised to exploit the potential of EFs to enhance learning was based upon the use of two levels of EF rectification.

On the 'first level' are the 'major' or primary EFs - the rectification of which is considered to be essential for learning to continue satisfactorily. This condition is apart from any possible benefits which could be gained by the correction of such EFs in terms of accelerating rates of learning. Below these, in order of priority for rectification, are the 'second level' EFs. These are 'minor' or secondary type EFs which are not so influential

in terms of any benefits which their correction would give to significantly enhance learning. It is therefore considered that the rectification of these 'second level' EFs is not so essential and does not need to be so timely as the 'first level' EFs. Hence, decisions concerning the rectification of 'second level' EFs depends on other factors, such as the time available or the particular learner's needs. This view is one which mainly evolved during the course of the experiment. However, Lee (op.cit.) has also suggested that the teacher may wish to 'order' his error treatment measures, but he has made no attempt either to investigate this conclusion experimentally or devise a scheme for this purpose.

It should be emphasised that the main EF diagnosis and classification measures which were employed in this study were primarily devised to account for both predicted and unpredicted 'first level' EFs (in the initial stages at least). Nevertheless, some provision was also made for diagnosing and rectifying 'second level' EFs. The actual scheme which was employed for this was essentially that of the general 'contingency plan' that was devised to cover the detection and classification of such EFs as they arose. This approach was adopted because of the range and number of 'minor' EFs which the pilot studies had indicated could occur, even in specific learning contexts.

This scheme was further reinforced by the active promotion of a general awareness of EFs (on behalf of both the learner and the teacher) and the use of a 'brainstorming' strategy. Reference to the 'Teaching Log' provides several illustrations of cases where these contingency measures were found to be helpful. For example, some students were found to have made errors in their calculations of 'frequency' (such as with test problems of type 5) and this was found, using these special diagnostic measures, to be due to minor confusion regarding conversion of the units to be calculated. However, even though this was really only a 'minor' EF it was dealt with immediately it was identified by these measures, and rectified according to the strategy postulated earlier. (This was done in order to prevent this and similar confusions being repeated or transferred to later topics.)

EF EXPLOITATION

One of the most significant properties of EFs in the context of this investigation is their potential for exploitation in order to enhance learning. This exploitation may take several forms in the classroom and some of these have already been described. Moreover they can sometimes be used as aids

to improve levels of motivation and rates of learning. In this experiment the use of EFs to 'stretch' learners was also investigated as was their use for giving students experience of certain pitfalls.

The general exploitation of the predicted 'first level' EFs was found to be a fairly straightforward exercise. It was carried out in conjunction with EF correction strategy which was prepared for this particular investigation. The approach involved the provision of a clear explanation so that the student understood that his errors were due to basic confusion, why this was so and how he could learn from this. After this had been established, the student was then told and shown the correct method or true situation. (In such a way that all associated confusion was also rectified.)

In certain instances, such as with 'group' EFs, the system of 'teachback', was employed so that students learned from each others' difficulties. The special iterative measures, which were explained previously, were used to reinforce the establishment of correct understanding in cases where it was felt that this would give added impact to the students' learning. Simple 'post rectification tests' were used at the completion of each stage to confirm that EF rectification was satisfactorily maintained. However, the errors which were found to have arisen, as a consequence of 3 students using incorrect procedures when working out 'phase relationships and frequency ratios', were exploited by demonstrating the effects of the incorrect procedure and contrasting these with those of the correct one so that it was more fully exemplified. Various other 'first level' EFs that had not been anticipated, but which had nevertheless been identified by the special diagnostic measures, were similarly rectified in a way which would enhance learning. However, this was only carried out after careful consideration of the diagnosis and detailed examination of the evidence recorded in the 'teaching log'.

It is possible that some of the potential benefits which would have resulted from unpredicted EFs being rectified immediately after they were discovered may have been lost. However, if this had been done (without due consideration and careful preparation) perhaps the complete rectification and full exploitation of the EFs may not have been achieved. Furthermore, as Lee (op.cit.) points out, by miscalculating the potential effects of learners' errors the teacher can cause great difficulty. More comments will be made about this situation in the conclusions to this thesis. Nevertheless, it should now be emphasised that, apart from all the potential benefits and aids to learning which EF treatments can provide, it was also observed that

the general increased 'awareness' of EFs (which was promoted by the use of these measures) helped to improve the students' general concentration and performance compared to that of the 'control' groups.

Initially, the various measures for 'first order' EF exploitation were carried out with all the 12 students in the group. This was undertaken according to the general procedural framework outlined earlier. One reason for this was because of the difficulty in 'administering' the EF correction measures separately to part of the group only. However, this is secondary to the chief reason for carrying out rectification of 'first order' EFs with all students in group 'A'. The reason is that some students may have only marginally not made errors (and were thus not identified with those who did make major errors). Hence, these students may not have been fully conversant with the topic or aware of all the pitfalls, and so would also benefit from the EF rectification exercise.

The scheme which was employed for EF removal also involved the use of what could be called a 'zoning method'.. That is, problems in say the understanding of 'phase', were 'zoned' for joint rectification so that correction exercises would be simplified and transfer of learning would be maximised. This was found to be a more efficient way of correcting EFs than by random rectification. Furthermore, it was also found that it took less time overall to rectify EFs that had been 'zoned' in this way. All these findings will be dealt with in greater depth in the final chapter along with suggested modifications to the measures which were employed for EF rectification and exploitation.

TEST RESULTS

Prior to the commencement of the experiment all three groups of students were given pre-tests on the topics which had been selected for this investigation. (These were formulated in conjunction with the lecturer who taught group 'C' and were double-marked by him). All three groups of students had comparable mean test scores before the intervention measures. (In fact, the mean scores for group 'B' were a little higher than the other two groups.) However, after the 'experimental group' (i.e. group 'A') had undergone the special EF treatment scheme there was a marked improvement in their mean test scores in comparison to the other groups.

SUMMARY OF ATTAINMENT TEST RESULTS

| GROUP | MEAN SCORE | STANDARD DEVIATION |
|-------|------------|--------------------|
| 'A' | 70% | 2.72 |
| 'B' | 57% | 5.10 |
| 'C' | 52% | 4.90 |

TABLE 9

Reference to the 'attainment test' summary results in Table 9 reveals the significant improvement which the special schemes devised for EF treatment produced with Group 'A'. All the three groups' mean attainment results at the start of the course were quite similar as were the respective standard deviations (in the case of groups 'B' and 'C' the standard deviations remained virtually unchanged). Since this investigation was only an initial attempt concerning the systematic use of EFs to enhance learning, it is probable that with the undertaking of certain modifications, which will be suggested later, and with further innovations, even greater improvements in attainment could be achieved in the future.

A further important observation arising from this investigation which deserves mention is that the 'attainment tests' were taken some five and a half weeks after the students had completed the last topics. Hence, it therefore seems possible that the EF treatment strategy which was employed can produce quite long lasting effects on improving learning. Various other incidental data obtained from general student 'feedback' and retrospective analytical discussion with the students at the end of each of the three topics, reinforced the conclusion that was stated earlier concerning the beneficial effects on students' motivation which these special EF treatment measures can induce. It was also discovered that, after rectifying their EFs, a greater respect concerning the need for more care in working (and learning) was established with the 'experimental' group. Hence, there is a possibility that a consequent reduction in the number of errors due to carelessness was also achieved as a result of these measures. All these

factors have contributed to the improved attainment and performance which was observed with group 'A'.

ANALYSIS OF ATTAINMENT TEST RESULTS

| Percentage marks | Group 'A' | Group 'B' | Group 'C' |
|------------------|-----------|-----------|-----------|
| Maximum | 86 | 71 | 65 |
| Minimum | 59 | 43 | 39 |
| Average | 70 | 57 | 52 |

TABLE 10

Detailed results of the 'attainment tests' are shown in Tables 10 and 11. As can be seen from Table 10, the minimum percentage marks for group 'A' were higher than the average percentage marks for groups 'B' and 'C'. Both groups 'A' and 'B' were taught by the author and group 'C' was taught by a lecturer who employed a rather 'errorless learning' scheme of teaching. It should be remembered that none of the three groups were made aware of this experimental investigation (neither was the other lecturer informed about the exact nature of the study). Furthermore, only group 'A' was taught to 'think' about their confusion and errors (along the lines advocated by Gilbert (op.cit.) which were mentioned earlier). It is interesting that both the maximum and minimum percentage marks for group 'A' were considerably higher than for the other two groups of students.

The frequency of higher attainment scores shown for group 'A' in Table 11 clearly indicates the correlation between the use of the EF treatment strategy and improved student attainment. The 'attainment tests' were all formulated with the assistance of the lecturer who taught group 'C'. The other lecturer was involved in order to reduce any prejudice or other difficulties, and to account for any statistical variations due to the author testing only that upon which he may have specially concentrated. Perhaps it would be unwise to validate the effectiveness of the strategies

devised for treating EFs completely on the basis of these test scores. Nevertheless, the final examination marks for the topics in question also show a similar patterns. Moreover, as can be seen from Tables 10 and 11 the results are so significant that they provide considerable support for the increased use of such strategies in the classroom.

| No. of students in Groups with marks in ranges shown | Frequency (Group A) | Frequency (Group B) | Frequency (Group C) |
|--|------------------------|------------------------|------------------------|
| 70 - 80% | 4 | 1 | 0 |
| 60 - 70% | 7 | 5 | 4 |
| 50 - 60% | 1 | 4 | 5 |
| 40 - 50% | 0 | 2 | 2 |
| 30 - 40% | 0 | 0 | 1 |

TABLE 11

REMARKS CONCERNING THE 'TEACHING LOG'

It was explained that the experiment would be carefully monitored and important observations or findings recorded. The use of a 'teaching log', which is shown in the following section, was the main way in which this was achieved. At the start of each new topic or stage of the investigation the 'log' was examined and analysed. so that any modifications or changes of strategy were identified. This exercise also meant that the experimental techniques for EF treatment were updated and refined during the course of the experiment. This was found to be a particularly valuable facility.

EXTRACTS FROM 'TEACHING LOG'

The following is a precis of notes made during and after the teaching of every stage of each 'topic'. Since the 'log' is quite detailed only a few relevant extracts from each stage and topic of the investigation will be given here in order to illustrate various points.

EXTRACTS FROM INITIAL STAGE

Good start to special teaching programme. Introductory EF treatment strategies seems quite helpful: Care taken to avoid indicating to students that special measures are being undertaken: 'Test questions' proving useful for early diagnosis of EFs - but am also watching out for any unexpected 'bugs'. Valuable discussion of possible errors/misunderstanding of the concept of 'phase'. This led to the realization that many students did not really appreciate their confusion or errors even when initially informed of these.

EXTRACTS FROM TOPIC 1

A number of 'minor' EFs now observed (e.g. 4 students made errors in calculating 'frequency') - decided to deal with these 'minor' EFs as they arose. Some further errors due to 'carelessness' noted in students' answers to 'supplementary' test questions.

Major confusion regarding interpretation of 'phase relations' observed - this had not been anticipated (employ interim contingency measures?). Decided to give this more thought (after lecture) before attempting to deal with it. EF prediction strategy has so far been quite satisfactory on the whole (1 predicted and 2 unpredicted major EFs detected in final stage).

EXTRACTS FROM TOPIC II

Now running behind the timetable for this topic (partly due to EF detection/identification exercises for Topic I taking up extra time). Diagnostic strategy now proving very satisfactory in operation.

Observe that there are already signs that this exercise has promoted an EF 'awareness' amongst students in 'experimental' group.

Some significant confusion regarding later stages of this topic observed only after analysing the special 'supplementary' test questions/answers of students. Although this had not been anticipated it was revealed because of 'open-ended' nature of certain 'test questions'. The special contingency measures enabled this confusion to be dealt with. A few 'minor' EFs also identified - dealt with this as soon as confirmed by 'test questions'. The total number of 'major' EFs detected for this topic is 5 (i.e. in addition to the 6 detected for Topic I).

EXTRACTS FROM TOPIC III

As this stage is partly practical it is therefore difficult to fully supervise the student experiments - student information/algorithm used with 'experimental' group seems to have reduced these difficulties.

Summary of comments from students on Topic III - algorithm very helpful but they wonder would they do so well if they did not have this support in future?

GENERAL COMMENTS (observations made over duration of experiment)

Found most students in 'experimental' group to be more motivated than in 'control' group. The use of 'teachback' seems helpful in EF identification/removal context. About 30 'minor' or 'second order' EFs detected for Topics I, II and III during course of investigation.

SPECIAL COMMENTS ON EF RECTIFICATION

EF removal strategies working well - requires more time than anticipated. Decided to undertake major EF rectification concerning misunderstanding of 'phase' with whole 'experimental' group (because of difficulty regarding the treatment of other students in group who did not have 'common' EFs).

The rectification of confusion regarding 'phase relationships' on the lines advocated in general procedure seems quite successful - discussion needed to clarify various points and assist transfer of learning of 'phase' to other contexts.

Results obtained indicate the main objectives of EF rectification for Topics I, II and III have been satisfied. Approximately 15% of the teaching time for each Topic was taken up by EF rectification measures for Topics I and II. However, found that students in 'experimental' group, after undergoing the first EF rectification exercise, also now making fewer random errors than those in other groups.

GENERAL NOTES (Recorded in 'teaching log')

The three student groups given tests 5½ weeks after end of Topic III. 'Experimental' group results significantly better than other two. Of the total teaching time for Topics I and II the EF diagnosis, rectification and exploitation took up approximately 25% of the time. Perhaps need to confine EF treatment in future? (or only concentrate on significant EFs, i.e. 'major' EFs which affect a number of students).

SUMMARY AND GENERAL CONCLUSIONS

This experimental investigation concerning the role of EFs in teaching has helped to demonstrate how great and diverse this role is. It has also clearly shown that, as Gilbert (op.cit.) suggests, correction of even minor confusion can significantly improve a learner's performance and attainment. Furthermore, the empirical data and other evidence which was obtained from this investigation has helped to support the hypothesis, which was presented earlier, concerning the significant potential of EFs as tools for enhancing students' learning efficiency. Moreover, the investigation has provided a number of fresh insights concerning the general nature of EFs, which theoretical research alone could not have identified. Similarly, this enquiry has also led to the identification of some interesting properties, which were previously described, regarding the 'levels' or 'orders' of EFs for rectification purposes. These findings demand a fresh appraisal being made of the general criteria for determining priorities of EF rectification.

Apart from the validation and reinforcement of the findings obtained in the pilot studies, this experiment has also served as a useful function with respect to the actual field trials of the measures which were devised for EF treatment - in a protracted investigation and in a well 'structured' learning environment. Moreover, since group 'C' were taught in a clinical and almost 'errorless' learning environment, which was similar to that advocated by Terrace (op.cit.), this experiment has also provided an interesting comparison of the two alternative strategies. The results of this comparison suggests that there is generally more to be gained

by the teacher acknowledging and exploiting EFs in learning than using an 'errorless' approach.

As can be seen from reference to the 'log', the measures undertaken for EF rectification required up to 15% of the time available for Topics I and II. In total, the EF diagnosis, rectification and exploitation measures required about 25% of the teaching time to be taken up. Nevertheless, the observations reported in the 'log' concerning the time required for the employment of schemes for EF diagnosis and rectification with the 'experimental' group must be viewed in perspective. For instance, after greater practice and experience regarding the use of the EF strategies the time required to carry these out could be quite considerably reduced. Furthermore, as the evidence and data concerning increased attainment, improved comprehension, and so on, clearly reveals, the value of these measures in the learning context more than justifies the time required.

Moreover, in terms of 'cost effectiveness' the time to learning achievement/enhancement ratio was actually higher than when normal teaching strategies were employed. However, if only 'first level' EFs were treated using the special measures in future, then the time requirement could probably be further significantly reduced. Thus, if 'time' was a priority factor for the teacher, he could decide for himself which 'second level' EFs, if any, he will treat. What is particularly important in this respect, is that EF treatment measures must be carried out according to a well designed plan, otherwise the general exercise could create more difficulties than it resolved. It should also be remembered that, as Brann (op.cit.) has observed, 'undesirable' EFs may result from poor verbal communication or written instructions. Hence, the teacher must take his own 'preventative measures' in order to avoid generating such EFs - which would thus save time in the long term.

Various modifications to the EF 'diagnostic framework' have already been discussed and analysed. However, all of these are really only minor modifications, with one exception. This exception is an alteration of the EF 'diagnostic framework' to cater for certain 'first level' or 'major' EFs which had not been specifically anticipated. For several reasons, which will be made clear later, this type of modification will be examined in greater depth in the final chapter. Regarding the EF prevention measures, it was noted that all the students in group 'A' said that they found the algorithm which they were given for use with Topic III was very helpful. (No difficulties were observed and no single error was actually made in their using the oscilloscope for the prescribed experimental work on this Topic.)

Although several of the students made the comment that, without the availability of a similar algorithm on future occasions they may experience confusion, it is not really considered that this would be so. However, an alternative scheme could perhaps be devised in future which does not have such specific reliance on the employment of algorithms for EF prevention.

It was found that the general 'guided discovery' teaching approach, which was employed with the 'experimental' group introduced a few minor problems with regard to the increased incidence of some 'secondary' type EFs. A possible reason for this was because the number of variations in the approach adopted by different students led to variations both in the type of 'minor' EFs and the sequence in which they were encountered. For example, several students were observed to be confused with regard to the conversion of certain numerical values when calculating the frequencies which they had obtained from their experiments. Since this confusion occurred at different rates and took different forms, 'individual' EF rectification often had to be employed (so as not to upset or restrict the process of learning by discovery). However, this reduced the efficiency of the EF rectification strategy and took up extra time. Perhaps, in future, some built-in 'control factors' could be introduced into the 'discovery' situation to help reduce these difficulties. These points will be discussed in more detail in the final chapter.

In the course of the experiment, it was observed that there were various factors in the teaching strategy, in addition to those already anticipated, which could influence the EF 'threshold'. This 'threshold' is a measure of the acceptable number of 'secondary' EFs which will not have an undue effect on impeding learning progress if they are not treated or removed. It is therefore suggested that it could be left to the individual teacher to decide on the magnitude of this 'threshold' because the variables involved are so considerable and, as was found, sometimes unpredictable. Nevertheless, basic rules concerning the diagnosis and rectification of 'second level' EFs could still be provided for the teacher (along the lines which were previously advocated) if the 'contingency measures' explained earlier are also employed.

However, this investigation has revealed that, although the rectification of 'major' EFs using the measures specially formulated for this purpose is comparatively straightforward, the rectification of certain 'sub classes' of these 'major' EFs can be more difficult and time-consuming than had been expected. Again, the teacher himself could assess the requirements for sub-EF rectification in the light of the particular learning

situation. These minor problems and difficulties should not discourage the teacher from employing the schemes which have been advocated. Moreover, it is felt that any schemes for treating EFs should leave the teacher free to adopt or implement them according to the particular circumstances and the time available. In fact one of the weaknesses of Scandura's (op.cit.) 'structured learning' strategy is that it is somewhat over-rigid.

Regarding EF diagnosis, the findings of this investigation suggest that the more varied and diverse the diagnostic 'test questions' which are employed, then the more successful and complete the EF identification which results. In addition, the investigation has helped to demonstrate the viability of the use of EFs in the context of problem solving in order to 'stretch' students and to improve their motivation. Perhaps in future the strategy of 'heuristic reasoning', as described by Polya (op.cit.) could be embedded in the diagnostic measures for EFs and also employed for the 'characterisation' of learner's difficulties.

The variance shown in the 'attainment test' scores between the 'experimental' group students and the other two groups gives some indication of the effectiveness of the special EF treatment measures which were devised. Moreover, the empirical data which was obtained from the various tests provides further reinforcement for the conclusion that learners are often alike in their confusion and errors. It was found helpful to employ a 'teaching log' and also to classify EFs prior to their rectification or exploitation. Perhaps, it may prove illuminating in a future investigation to observe the effects on students' attainment of only rectifying 'first level' EFs.

A final conclusion with regard to EF diagnosis, which has arisen from this investigation, is that the 'testing' of students' understanding and performance should include some means of testing ignorance. Moreover, the students in group 'A', who were given the special EF treatment, claimed that this was the first time that they felt they had really 'understood' a subject in general. It is also interesting to note that, after seeing the 'attainment test' scores and all the other evidence, the lecturer of group 'C' was particularly impressed and consequently decided to adopt these measures in his own teaching. Nevertheless, much more experimentation requires to be undertaken in future, especially regarding the exploitation of EFs. However, such investigations could lead to a more universal acceptance amongst educators in general of the true role of EFs in teaching. This is one of the important themes which will be considered in greater depth in the final chapter.

CHAPTER 5

General Summary, Conclusions and an assessment of future directions for further research

INTRODUCTION

In this final chapter a careful appraisal will be made of the implications of this exploratory investigation concerning the role of EFs in teaching. Furthermore, it is intended to assess all the data and evidence which was obtained from the empirical studies with a view to reinforcing the general hypothesis that the teacher can gain much from examining student error in a more insightful way. The eclectic approach which was adopted in this investigation has helped to reveal a number of significant methodological implications concerning EFs and these will be subsequently examined in detail. Moreover, despite the scant literature in this sphere a number of worthwhile theories have been explored and certain premises concerning the general functions of EFs in the classroom (which must now be consolidated) have consequently been established. In addition, an assessment will be undertaken of the possible contributions that this investigation has made towards filling the numerous gaps in our knowledge in this context. An attempt will also be made to speculate about the potential role of EFs. Finally, suggestions will be made regarding future research issues arising from this study.

SUMMARY AND COMMENTS ON THE PROPERTIES OF EFs

EFs are vector quantities which can be directed and exploited by the employment of special techniques. Since little is known about the nature of EFs it was thought to be a good strategy to undertake two different pilot experiments - especially since it would enable each study to be built on the findings and rationalised objectives of the preceding one. This also meant that the major experimental investigation of strategies for treating EFs could be more carefully structured in order to provide empirical evidence regarding their properties.

The concrete examples which were presented in earlier chapters have enabled it to be definitely established that there are EFs and these can seriously obstruct learning. Furthermore, it was found that they can have 'informative' as well as 'punitive' effects on learning. There were examples given in Chapter 2 which illustrated how EFs can become deeply entrenched

and promote clusters' of associated confusion. Moreover, various 'case studies' and protocols were presented which suggest that EFs can undergo 'metamorphosis' - such that they promote changing dimensions of confusion. These findings endorse those which have been reported by Lewis and Pask (op.cit.) in this context.

Definite patterns of confusion were identified with each of the different groups of students examined in the two pilot experiments. Similarly, in the major experimental investigation distinct similarities in students' confusion and errors were observed. This evidence provides reinforcement for the view of Olsson (op.cit.) that learners are frequently alike in their basic errors and misconceptions. Furthermore various EFPs were identified during the investigations and it now felt that their influence in creating EFs may be even greater than was originally believed. This situation will be examined later in more depth in the contexts of EF diagnosis, removal and exploitation. Certain problems in the categorization of errors which were suggested by Strevens (op.cit.) were encountered, but the provision of an EF classification scheme enabled these problems to be generally satisfactorily resolved. Nevertheless, it is suggested that specific sub-classification of 'topic' or specific 'subject matter' EFs is best left to the teacher to carry out himself.

A further property of EFs which was identified in this study is that they can become more active in the presence of what may be referred to as 'EF catalysts'. Various examples of these were identified in this enquiry and their influence on EFs has been found to be quite great. However, it should be pointed out that 'EF catalysts', such as poor insight, are preventable if what the author calls 'effective teaching' is adopted. This is based on the strategy originally proposed by Gilbert (op.cit.) which will subsequently be discussed more fully. Moreover, it is also suggested that the employment of 'brainstorming' techniques can help to reduce the effects of 'EF catalysts' with certain, more experienced, learners. However, further research must be undertaken in this context in order for more comprehensive measures to be formulated and explored.

The philosophical implications of the nature and properties of error have been shown to be quite significant. In particular, the views of Royce (op.cit.) concerning errors of judgement, which were examined in depth, led to the formulation of a number of useful ideas with regard to the strategy of teaching 'thinking'. Furthermore, concerning the question of 'arbitration' with respect to assessing the interpretation of texts, this investigation suggests that the employment of a 'yardstick of

correctness' is generally appropriate for this purpose. While it is concluded that the nature of EFs is somewhat complex, as this study has shown, they can, nevertheless, be frequently predicted and detected. Moreover, it has been demonstrated that EFs can sometimes be prevented or restricted by the adoption of certain measures, such as altering the structuring of the learning task or changing unsatisfactory learning styles. Therefore, the teacher can have a degree of adaptive control over 'undesirable EFs' in the classroom. These observations concerning the properties of EFs will be examined later in more specific contexts.

CONCLUSIONS REGARDING THE EF DIAGNOSTIC FRAMEWORK

The strategy devised for EF detection and diagnosis which was used in the main experiment had been successively refined and modified during a series of preliminary investigations and pilot experiments. Consequently this process resulted in the production of a diagnostic framework for EFs which embraced a whole sequence of strategies and techniques. Perhaps some of these composite strategies could be incorporated in the design of the remedial structure of an 'adaptive' teaching machine. It is interesting that similar proposals have been advocated, but in more general terms, by Lewis and Pask (op.cit.). This suggestion will be examined further with respect to future research in this context.

The effectiveness of the overall EF 'diagnostic framework' was demonstrated by the major experiment which was described in the previous chapter. Nevertheless, it is considered that the overall diagnostic strategy could be more effective if employed in a well structured teaching environment. Furthermore, it must be pointed out that certain conditions, such as lesson timing or frequency and syllabus or curriculum arrangements, could often be better organised than often appears to be the case at the moment. This could also mean that the problem of teaching-time consumption, which the EF diagnostic measures demand, could perhaps be reduced by a considerable amount if the suggested improvements in teaching organisation were undertaken first. However, while these proposed changes are not felt to be essential for the satisfactory functioning of the diagnostic scheme, they could clearly improve its efficiency.

Regarding the initial diagnosis of EFs, it was concluded that the use of different types of 'test questions' can be helpful in two ways. First, it may enable 'systematic' or 'idiosyncratic' EFs to be revealed - which would not be possible if only one type of 'test question' was being employed. Secondly, this strategy could help to reveal any patterns of EFs due to



Mobile feedback classroom system

misunderstanding certain forms of question. Moreover, it should be noted that 'open ended' diagnostic questions can be particularly useful for indicating the general effects of learners' confusion and also the possible degree of transfer of misunderstanding. Nevertheless, in order to identify and confirm the underlying causes of confusion it is considered that an 'elicitation technique' should be adopted, along with the use of 'supplementary' test questions, 'feedback' analysis and retrospective 'error profile' examination.

In addition, it must be emphasised that the use of an electronic 'feedback classroom' may be a particular help if the teacher has large groups of students - especially for final and specific EF identification. Furthermore this facility can enable a whole range of simple 'supplementary' test questions to be given to the learner, and his responses immediately recorded. As can be seen in Plate 4, the unit which was devised for this purpose is quite mobile, and yet it can be used to test a large number of students simultaneously (and enable their individual answers to be observed 'collectively' in the same process). This particular unit was designed and built by the college staff and could be replicated without much difficulty. The synoptic evidence which this system provided was also found useful for detecting any 'associated' EFs or 'group' confusion. Furthermore, the provision of such a system could save the teacher time in marking tests and give him information about learners' confusion while he was actually teaching them.

With respect to making use of EFs in teaching, it is important that 'informative' and 'useful' EFs are clearly distinguished by the teacher from 'punitive' EFs. It was found helpful in this context to undertake an analysis of EFs using a 'cause and effect' approach. Moreover, the employment of this strategy meant that obscure EFs could be identified, within the overall 'diagnostic framework', by examining and subsequently eliminating each possible cause of the observed effects on learning. In a future investigation it could be valuable to explore a range of potential applications of this approach in other diagnostic contexts.

The 'precipitation' technique which was formulated to enable the 'fundamental' EF to be determined from a number of potential EFs in a given context, proved to be quite useful in practice but was somewhat laborious. This technique was based on a process of 'progressive elimination' of respective EFs which has also been advocated, but on a more limited scale, by Brown and Burton (op.cit.). However, by compiling a 'hierarchy' of EFs in a particular context and preparing a frequency table for 'common' EFs

it was found possible to obtain a quick 'first approximation' of the underlying cause of confusion. In this way some of the initial work involved in the 'precipitation technique' could be reduced. Furthermore, improved EF predictions could be achieved if the above strategy was suitably reinforced with other evidence such as 'entry test' data and students 'EF profile' information.

It was observed that the 'elicitation technique' which was employed for diagnosis of the root causes of confusion was greatly facilitated by the development of a co-operative learner attitude concerning EF diagnosis. It was also aided by the examination of the findings which were recorded in the 'teaching log'. It is, therefore, strongly advocated that even fuller consideration is given to these factors in the future formulation of EF diagnostic frameworks. Moreover, it should be noted in these conclusions that Kellerman (op.cit.) has also reported on the value of 'elicitation techniques' for error analysis in the context of language learning. He has formulated a special scheme for diagnosing students' errors in learning English. This is equivalent, in terms of 'linguistic learning', to the schema which was devised for EF diagnosis in mathematics and physical science contexts.

Summary of factors to be accounted for in EF diagnosis

1. Account for 'frequency' of EF.
2. Account for Area or points of difficulty produced by EF.
3. Account for Cause of EF.
4. Account for Effect of EF or degree of disturbance on learning.
5. Account for type of (and classify) EF.
6. Account for subsequent therapy or remedial treatment of EF.

It is suggested that in order to account for EF 'frequency' one of the best methods of recording this is the 'teaching log' (especially since this is a record of both 'individual' and 'group' EFs). This measure proved

to be particularly useful in this respect and it is proposed that more use could be made of this in future - including its employment in the planning of measures for EF prediction and prevention. An examination of the observations and evidence obtained from this investigation concerning the effectiveness of the diagnostic measures which were employed, indicates that 'test questions' where conflicting facts or statements are used to detect misunderstandings are also helpful in revealing the specific 'areas' of difficulty or confusion. The latter technique has an additional merit for EF diagnosis because it is less likely to create or modify EFs than other measures. In accounting for the 'type' of EF, it is concluded that some rationalisation would be of help regarding the classification criteria which were originally formulated. It could also prove to be useful if a hierarchical EF classification scheme was employed in future, such as the 'EF tree' classification system shown in Figure 26. However, with regard to taking account of the causes and also the various effects of EFs in terms of their diagnosis, the strategies which were devised for these purposes appear to require little rationalisation or modification. Nevertheless, as a result of further studies and experience in teaching EFs it may be possible to identify new areas of application for these measures.

EF PREDICTION

There are a number of important conclusions regarding EF prediction which have arisen from this investigation. For instance, it has become evident that EF prediction schemes must take account of any presuppositions which the student may have concerning the particular learning task. This may require the formulation and employment of special objective 'entry tests' to identify presuppositions. It is also suggested that it could also help if the teacher undertook a general analysis of the 'cognitive styles' of his students to see if he could predict certain errors and learning difficulties. (As was discovered in the main experiment.) Moreover, careful attention to 'feedback' and to a student's previous learning difficulties (e.g. as given in his 'EF profile') could assist in providing initial confirmation of the EF prediction conclusions which the teacher has formulated by the use of a special EF prediction model such as that previously described.

A further significant observation with respect to the prediction and provision of measures to treat EFs is that there appear to exist what could be termed 'parasitic' EFs which, if not removed, can considerably obstruct

'EF Tree' Classification System

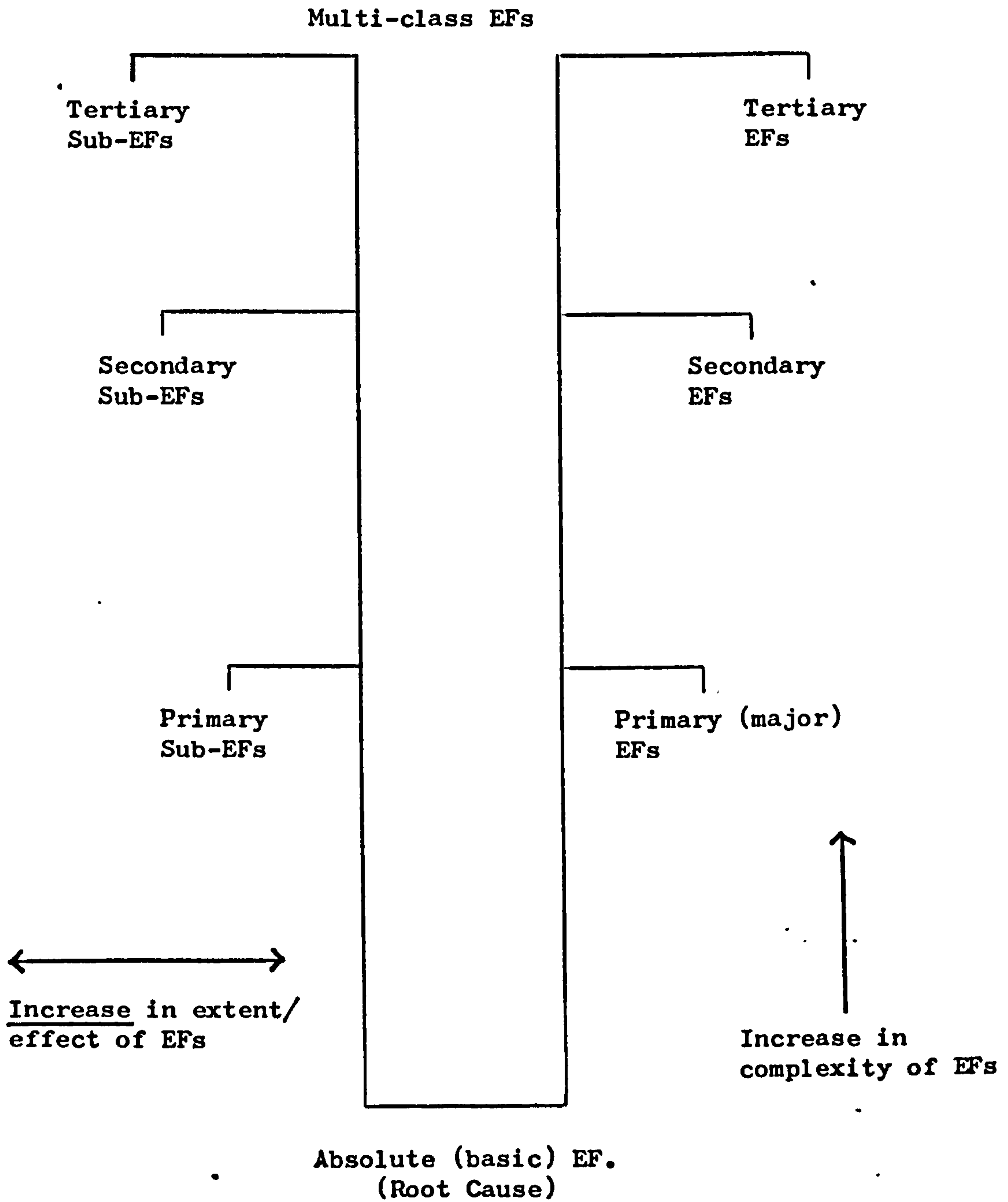

EF Termination: may occur at any lateral branch

FIGURE 26

learning progress. However, it has been found that they can often be predicted because they only occur if certain 'EF hosts' are present (or are predicted). The latter type of EFs are those which feed on lack of experience in a given context on the part of the student. Perhaps this is also the reason why some students tend to repeat misunderstandings or transfer them to other areas of learning ('parasitic' EFs have been found to exhibit a degree of mobility from one learning situation to another). This effect and type of situation seems quite marked during the earlier stages of learning a subject and can make EF prediction fairly difficult. It may be discovered, after further research has been undertaken that there exists a kind of EF 'operator' which acts on and alters other EFs. This would explain why a learner sometimes made an apparently 'irrational' error - because his basic confusion has been altered. If such an EF 'operator' was found to exist then the EF prediction strategy would need to be modified to account for it.

Parasitic EF growth

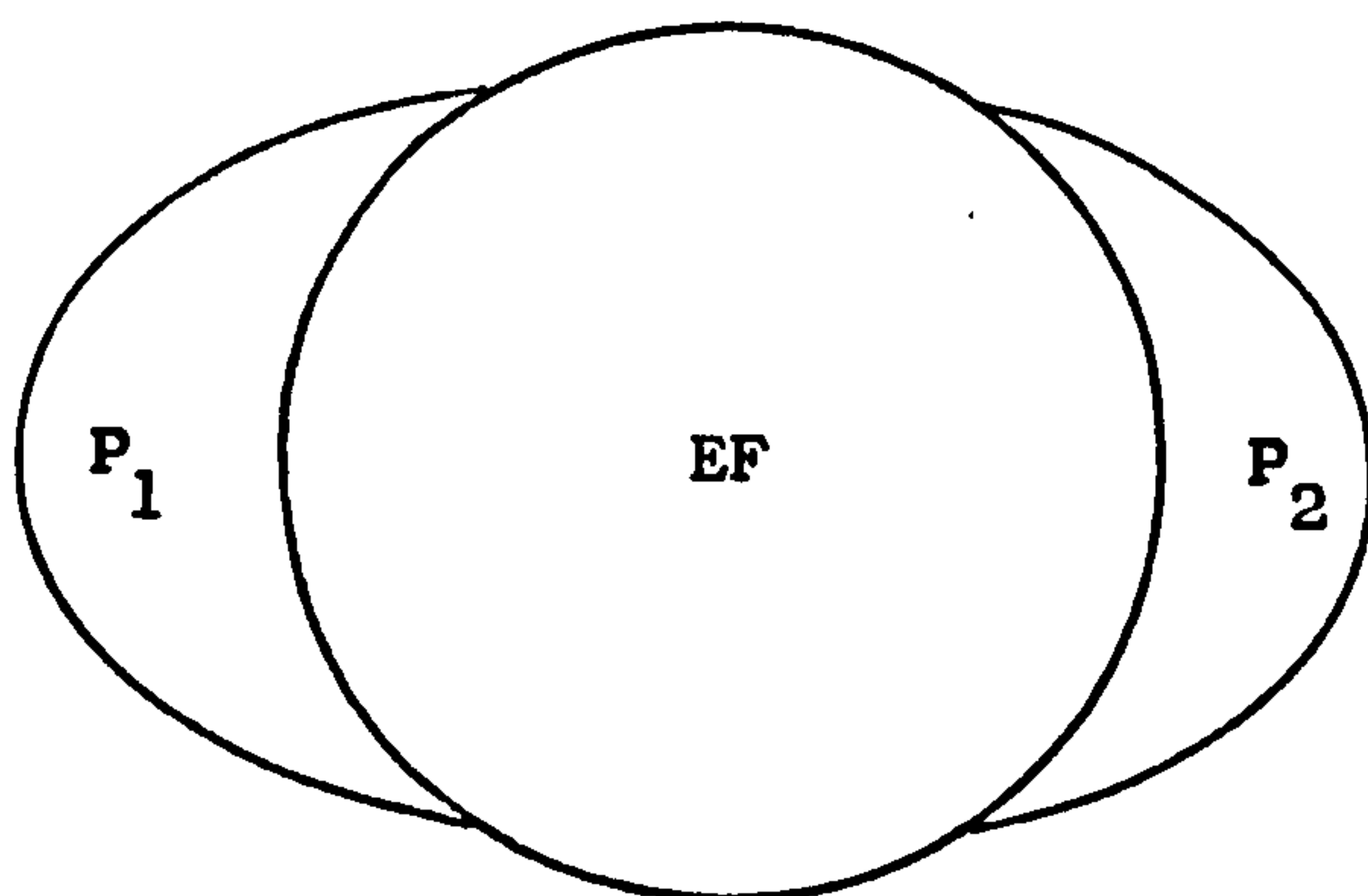

GROWTH OF TWO 'PARASITIC' EFs 'P₁', 'P₂' ON AN EF

A further conclusion which this study has promoted is that a student could be helped to use his experience of certain EFs to build up a repertoire of EF prediction measures of his own which he would then employ in new learning or problem solving situations. It is also suggested that it would be beneficial if EF prediction schemes take more account of 'retrospective' EF analysis than was originally considered. For instance, the teacher could

undertake this task in the same way that a doctor reviews and analyses a patient's medical 'case history' before predicting the possible course of his illness and deciding on its treatment. Moreover, if the teacher can predict some of the major EFs in a particular learning context he is better able to formulate diagnostic tests and prepare effective remedial measures.

A particularly interesting implication with regard to the prediction of EFs, which this investigation has revealed, is that the 'effects' of EFs often vary from one learner to another. For example, it was noticed in the analysis of EFs in the initial pilot experiment that several students had the same basic misunderstanding of electric circuits but they did not all make the same number or types of errors. It was also reported in the pilot experiments and the main experiment that students who made errors concerning one topic, frequently made errors concerning another related topic. Moreover, reference to the various tables of students' EFs given in earlier chapters shows that students who made errors caused by 'first order' or major EFs tended to demonstrate a 'susceptibility' to further EFs in that context. Perhaps more account should be taken of these observations with regard to EF prediction in future. Furthermore, it may prove to be worthwhile to acknowledge the conclusions of Robertson (op.cit.) with regard to errors and personality types. He reports that:

".... It was also possible to make predictions about the relationship between the number of errors that students' would make and personality dimensions".

CONCLUSIONS REGARDING EF GENERATORS

There are a number of implications and observations concerning the 'generation' of EFs which this study has prompted. For example, it should not be overlooked that the writers of textbooks and similar learning materials may be responsible for generating EFs. Several instances were observed where it was felt that students had become confused as a result of poorly written or poorly structured textbooks. There appears to be a need for some improvement in the general area of textual instruction in order that the creation of 'undesirable' or 'deep rooted' EFs is minimised. Unfortunately, it has also been observed that in many textbooks little attempt is made to undertake any remedial measures. Neither is the student 'prepared' in these texts for facing certain pitfalls and possible general misunderstandings. In addition, the author has noted that some textbooks are not particularly 'readable' and so they may produce some of the EFs arising from poor communication which were previously reported.

Summary of possible creators of EFs: (identified during this investigation)

1. Giving students too narrow or too wide an understanding.
2. Trying to avoid possible confusion by employing certain restrictions may cause further confusion.
3. Lack of 'flexibility' on part of teacher, e.g., using same method with all students on all topics.
4. Failure of the teacher to appreciate that a complex subject may have a large number of potential EFs embedded in it.
5. Not allowing the student to see why (and where) his EFs occur - thus he has no experience to help him.
6. Not organising and structuring teaching effectively.
7. Failure to recognise and remove early confusion may cause failure at higher levels of learning (may also affect 'motivation' at higher level learning - may in turn cause EFs).
8. Teaching which is not well 'ordered' to reduce the incidence of EFs - particularly since some EFs may help to multiply others.
9. Lack of initial awareness concerning EFs on the part of teachers, and students, - due to poor diagnostic measures (may also result in generating higher order EFs).
10. Poor knowledge of the nature of EFs on the part of the teacher - partly due to lack of information on the subject. (Many teachers simply rely on their intuition in this respect).
11. Lack of consultation with the student concerning his learning difficulties - i.e., teacher should not just assume nature of a student's problems without discussion with the student.
12. Failure on part of teacher to identify the basic source of confusion - may result in further EFs being created (and the inefficient removal of EFs which do not have this same basis).

N.B. All these are in addition to, or overlap with, the possible generators of EFs discussed elsewhere in this thesis.

GENERAL CONCLUSIONS ABOUT THE RECTIFICATION AND EXPLOITATION OF EFs

This study has attempted to demonstrate that the exploitation of EFs to enhance or accelerate learning is a strategy which offers great potential for the teacher. Moreover, it has been shown that the rectification of the underlying causes of confusion can not only be used to remove a cluster of associated confusion or misunderstandings (often in the same exercise) but also valuable 'transfer' of learning is often achieved. It is suggested that by using what Nickel (op.cit.) calls 'shock tactics' (i.e. piling up difficulties or potential EFs in 'test questions') the teacher can sometimes better assess and subsequently exploit a learner's EFs. In addition, the teacher may be able to 'control' certain EFs in order to help the learner to avoid particular difficulties until he is more ready to deal with them.

In this investigation it has been observed that, in general, it is advantageous to correct EFs soon after they have been diagnosed. It was found that EF rectification was generally more efficient and effective if there was not a long time delay between detection and rectification. Moreover, it is considered that if the teacher can regulate or manipulate EFs, he may then use these to add impetus to further learning. In order to regulate or control EFs, it has been found that it is best to divide the subject matter into 'modules', and then divide each 'module' into related 'topics'. This not only means that EFs can be 'contained' but also that they can be grouped and later be exploited at a more appropriate time. Nevertheless, it is suggested that there may be an acceptable EF 'threshold' which needs to be accounted for, regarding the maximum number of EFs that a particular learner or group of learners tolerate in a given learning situation.

It has been observed to be quite a valuable strategy to use EFs as a means of altering problem difficulty - especially in practical learning contexts. For instance, students could be given an electronic circuit (such as shown in Plate 5) which is designed not to function correctly in certain respects unless the student properly understands the functions of various components and how to employ them. The degree of confusion or difficulty in such a circuit can quickly be increased (or decreased) by the carrying out of a few minor alterations or by simply rearranging some of the components.

**TEXT BOUND INTO
THE SPINE**

10

ASTABLE (MULTIVIBRATOR.)

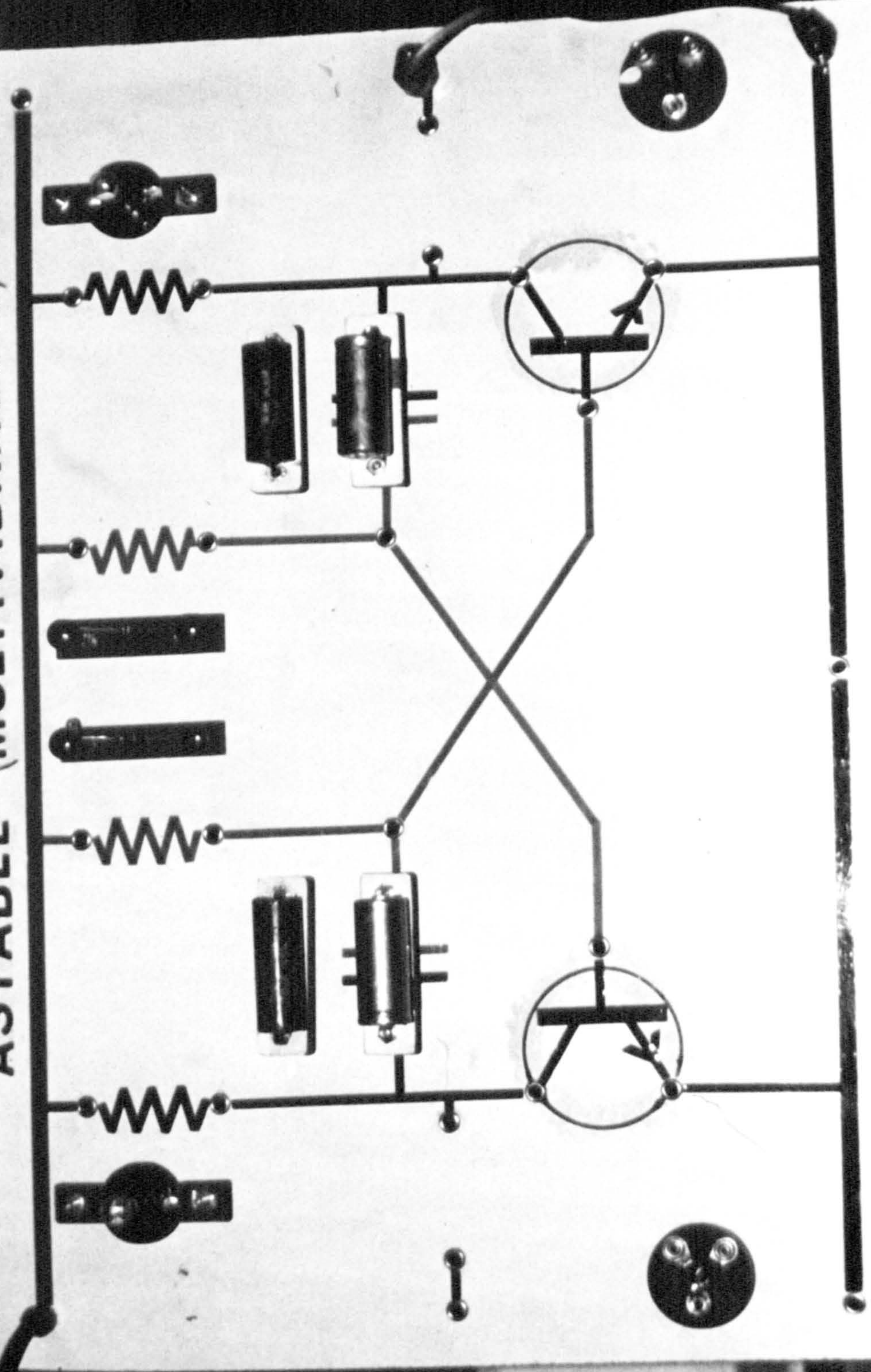

In the course of this investigation it has been noted that the rectification of EFs by the strategy of 'telling' as proposed by Lewis and Cook (op.cit.) is simple, direct and effective. Nevertheless, 'telling' alone may sometimes not be sufficient to rectify or exploit EFs. It may be necessary for the teacher to work within the kind of 'procedural' EF rectification framework which has been described in this thesis. Within this framework, set procedures have been devised to determine the best 'order' and the most suitable rate for EF removal. Concerning the rate of EF removal the evidence obtained suggests that this should be determined by the degree of learning transfer desired and the student's specific aptitude or learning capacity.

It is also proposed that the 'procedural framework' should embrace strategies such as 'feedback' analysis and exteriorisation of learners' confusion, with the object of enabling the whole group to learn from each other's EFs. Furthermore, it is considered that a student should be shown why he is making errors, and the cause then corrected, so that his level of motivation may be improved.

In the course of this enquiry it has been found that practical demonstrations and student experiments can be used to aid EF exploitation, especially if they require the learner to extend his new understanding (e.g. after undertaking 'learning by discovery' exercises). Similarly, it has been noted that 'useful' EFs can be employed in order to cause the student to ask questions about what he knows (or thinks he knows). Nevertheless, in terms of Pask's (op.cit.) 'conversation theory' EFs may be considered as 'inept' moves in the 'conversational' exercise, and, in certain situations, it has been observed that some EFs are 'self-correcting' or they cause the student to stop and reflect on his confusions in such a way that he identifies and subsequently corrects them himself. The following is a summary of the principal uses of EFs in the classroom, which have been identified in this investigation.

1. EFs can be used, in controlled conditions, to 'stretch' students and to increase their rates of learning.
2. The exteriorization of one student's EFs may be employed to illustrate potential confusion and to enable other students to learn from his misunderstandings.
3. 'Useful' EFs may be used to exemplify certain important teaching points and improve learning efficiency.

4. EFs can be employed to show students how to 'structure' their problems more effectively in problem solving contexts (and how to decide on the most appropriate procedure to employ).
5. A 'scale of difficulty' can be formulated so that the learner is exposed to EFs at an appropriate rate, and progressively learns 'how to learn' from his errors.
6. EFs may be used as tools to promote and maintain student motivation, or enrich learning.
7. An 'anatomy of a failure' in learning, due to EFs, can be used by the teacher to construct more effective teaching and remedial measures.

N.B. The above are all applications of EFs in teaching which are in addition to their use in resolving a number of misconceptions in a single process.

It is suggested that teachers should attempt to adopt a balanced view regarding the prevention of learners' EFs in future. For instance, as Lee (op.cit.) observes, some errors and misunderstandings may be helpful and are quite natural in situations such as 'language learning'. Furthermore, by deliberately introducing conditions where the learner encounters confusion and makes certain errors the teacher can promote a useful degree of 'caution' in the student. This strategy may also encourage the learner to be more reflective during problem solving. In addition, like the 'master performer' described by Gilbert (op.cit.), the student could learn from such experience the value of assessing the 'relatedness' of one EF to EFs in other areas. A 'network analysis' of EFs, such as shown in Figure 27, could be formulated to assist the learner in this respect. Alternatively, an extrinsically controlled EF rectification system could be devised to reveal the possible links between EFs in different areas/topics (this could take the form of an adaptive teaching machine). These latter conclusions and suggestions will be discussed more fully with reference to future directions of research.

EF Network Analysis

Possible links between EFs in the
same subject and two different
subject areas

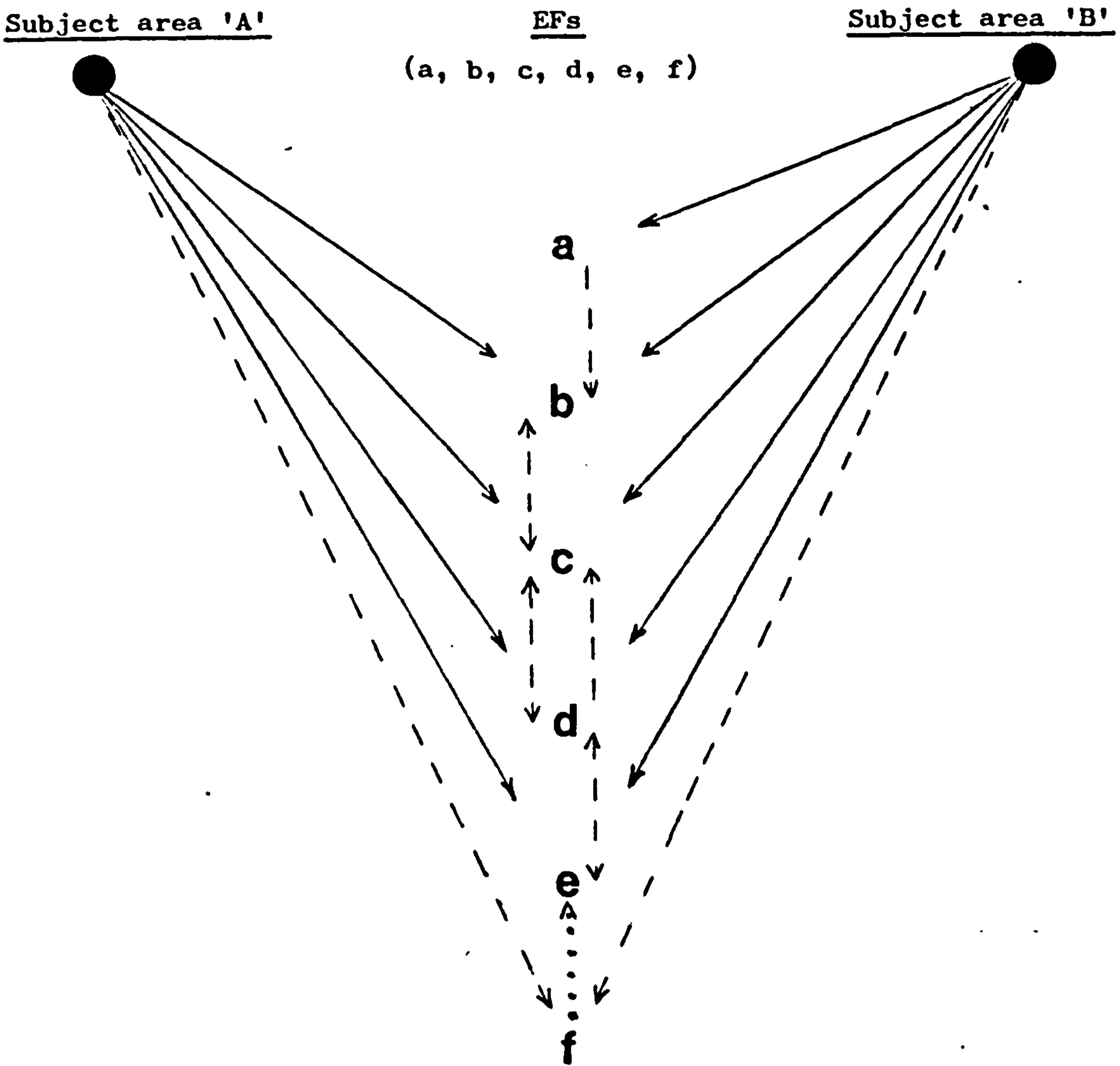

FIGURE 27

KEY

- Direct EF path
- - - EF link path
- uni directional EF
- ← - → bi-directional EF
-→ predicted EF link

EF PREVENTION

In the course of this investigation, there were several instances when it was considered to be expedient to attempt to prevent certain EFs. For example, this was felt necessary in some cases because the incidence of EFs could have seriously impeded further learning, produced a marked reduction in motivation, or promoted an undesirable student attitude towards certain topics. Moreover, it was considered to be essential that, in several practical contexts EFs were prevented because they could have resulted in safety hazards or physical danger. In addition, it was found that the recall of an error sometimes displaced the correct understanding. The findings of this enquiry also imply that it may be desirable for the learner to know clearly and to understand the 'truth' in some cases. Although various measures and constraints were adopted to reduce the incidence of certain EFs it was observed that these were not always sufficient. Therefore, special EF prevention strategies including the use of algorithms were devised for the main experiment.

It was observed during this study that EFs can often be prevented if the student is given clear instructions and precise information. Furthermore, it has been noted that the number of EFs which students encounter in disseminating information is reducible if the information is given in easily assimilated and 'readable' modules (but checks should still be carried out at each stage). The use of 'overlearning' has also been found to be of help in reducing confusion regarding the recall of facts or the undertaking of strategies. Similar results could perhaps be obtained by using "practice makes perfect" strategies - especially with less able students. Unfortunately, this measure could be rather time-consuming, somewhat inefficient and not always completely reliable. Furthermore, it was noted that the success of the 'iterative' strategy which was employed was to some extent dependent on the co-operation of the learner. However, when the potential effects of an EF were presented to the students this helped to reinforce the effectiveness of the preventative measures. Similarly, if the student was shown or told why an EF was to be avoided this also tended to make him more willing to take the necessary preventative steps.

The employment of algorithms for EF prevention was found to be quite a valuable strategy, especially in practical learning contexts. As reported in the results of the main experiment, the algorithm which was

devised to prevent certain EFs proved to be so effective for this purpose that no errors were made at all by the 'experimental' group. It is therefore strongly advocated that greater use is made of algorithms in this respect in future. A general observation concerning EF prevention arising from this investigation is that a more 'deterministic' approach to students' EFs could perhaps be adopted by some teachers. This is because it was noted that when learning was well 'ordered' and carefully structured then EFs were less likely to occur. Similarly, if particular EFs are diagnosed in good time then their root cause can often be rectified before the stage when their effects could be considered to be really significant or undesirable.

The evidence obtained concerning the use of the preventative strategies and rules which were devised for the purpose of EF prevention suggests that the opportunity should sometimes be given for the learner to formulate or adapt these for himself in order that he gains experience of EF prevention measures. The strategy for the avoidance of errors and confusion with respect to problem solving, which was based on one proposed by Polya (op.cit.) was found to be most useful and is also one that the student could easily learn for himself. This strategy is considered to be a good overall approach to general EF avoidance, since it is based on the learner checking to see if he understands what he is to do, planning how to do it, carrying out the plan, and then looking back again to check what has been done. In addition, it was found to be useful to encourage the students to adopt this approach when carrying out practical experiments in order to back up the main EF prevention measures. Finally, the results of the main experiment suggest that more attention should be given to improving the adaptability of the preventative measures so that they can be readily modified to deal with EFs which have not been accounted for in a particular learning context.

IMPLICATIONS OF STUDENT AND TEACHER ATTITUDES TO EFs

There are a number of implications arising from this study concerning both teacher and pupil attitudes towards EFs and their treatment. For instance, it was observed that it is generally important for the teacher to encourage the development of the kind of attitude regarding EFs in his students which was conducive to their active co-operation in EF treatment. It is suggested that the teacher can achieve this by encouraging the students to disclose their learning difficulties and confusion. A further implication concerning pupil attitudes is that the teacher should attempt to promote an informed and open outlook concerning EFs. This is because a

number of the students who were questioned in this enquiry explained that they felt less anxious or discouraged when they learned that others sometimes made similar errors and had similar learning difficulties. However, one of the most significant implications arising from the main experiment is that many of the students in the experimental group reported at the end of the study that they had completely changed their attitude to EFs and now felt that they could be used to their advantage. Moreover, although a number of the students were at first reluctant to discuss their errors, once they saw that they could be helped it was found that their inhibitions generally disappeared and they became quite enthusiastic.

With regard to teacher attitudes one of the most important general conclusions in this context is that while some teachers claimed to acknowledge students' EFs in their teaching, few of them seemed to hold the view that these could have any role in teaching. In fact, not one amongst over 30 teachers and lecturers who were questioned in this respect, considered that there was the possibility of exploiting EFs in order to enhance learning. A few teachers reported that they were not even inclined to concern themselves with examining student error. However, after showing these teachers the potential value and significance of EFs their attitudes generally changed and they also saw the need for adopting a more positive attitude to learners' errors. Similarly, many of these teachers said that they would try to modify their strategies to enable them to reduce the incidence of undesirable EFs. It should be pointed out that even the small number of teachers who claimed tacit acknowledgement of EFs in their teaching reported that they had previously not fully appreciated the significance or magnitude of the effects of EFs on learning. Furthermore, some of these teachers admitted that perhaps some of their idiosyncrasies and teaching styles could have actually generated EFs.

In addition to teachers, several groups of 'student teachers' were questioned about their attitudes concerning EFs. Some of them were also observed on 'teaching practice' and it was noted that they were often not fully aware of students' confusion or failed to recognise misunderstandings at an early stage. Many of them admitted that they had not appreciated that the students' errors and difficulties were frequently common ones - or that these may have been the same as those which they had experienced themselves at that stage and level. Consequently, these 'student teachers' rarely reflected upon their students' confusion or attempted to resolve it in an expeditious manner. However, after showing them some appropriate examples, 'case studies' and other evidence concerning the possible treatment

of EFs they were questioned again. A number of interesting observations were made about their changed views and attitudes. For example, some of them reported that they had come to realise that they had experienced similar learning difficulties and made errors similar to those of their students. Furthermore, some of them explained that they now appreciated why some of their 'teaching practices' had not been so effective or successful as they had wished. Finally, many of them said that they could also see, even from their own experience, that there were many opportunities to improve learning, by making use of EFs, presently being missed.

METHODOLOGICAL IMPLICATIONS

It has been noted that current methodology does little to acknowledge or treat EFs. However, there are various significant methodological implications resulting from this investigation. One such observation with respect to methodology is that a single 'demonstration' by the teacher is often inadequate for teaching the student how to solve a whole 'class' of problems. This conclusion reinforces that of Wallen and Travers (op.cit.) in this context. The findings also suggest that what can be helpful in this type of situation is the use of measures such as 'teachback' and the 'guided discovery' strategy, so that the student can develop and widen his problem solving techniques. In addition to revealing the need to alter methodology to more fully account for EFs, the findings of this investigation indicate that EF treatment strategies can frequently be integrated into general methodology.

A further methodological implication arising from this enquiry is that a 'heuristic' approach to problem solving, in the sense advocated by Polya (op.cit.) which was previously outlined, was found to be particularly conducive to 'effective' learning and learning from errors. Moreover, in the main experiment it was observed in a number of instances that the students in the experimental group were highly motivated by this approach. In comparison to the control groups they were also more adventurous and 'insightful' in devising their own strategies for problem solving. It was noted that their motivation was so considerably improved by the employment of this approach that they were all very keen to discuss their misconceptions and to help others in the group to resolve their EFs.

It has been observed that it is unwise for the teacher always to assume that the learner understands what he is being taught. Similarly, it also suggested that he should not adopt a methodology which assumes that all

students learn in the same way. Moreover, while the findings indicate that there is a place in methodology for 'rule learning' it is considered that, with regard to EF treatment, this should be subject to the constraints which were mentioned earlier with respect to the prevention of EFs. However, it was found that the use of 'ruleg' measures and algorithms were a major help in learning situations where there were a large number of potential EFs.

A major pedagogical issue which this investigation has revealed is that teaching should be structured in such a way that the causes of 'punitive' EFs that were outlined earlier are minimised. In addition, 'timeliness' in presenting learning items and the careful consideration of the order of their presentation are factors which it has been found must be accounted for in this respect. It has also been observed that teaching methods must not be so rigid that they do not allow EF diagnosis and rectification exercises to be undertaken when necessary. Moreover, the findings of this investigation suggest that the teacher could attempt to exteriorise a learner's confusion so that he can conduct an anatomical analysis of learning failure due to EFs—from which the whole class can learn. Similarly, it has been noted that the use of teaching strategies involving 'mediation', such as mediation between the 'cause and effect' of an EF, can provide suitable conditions for undertaking both EF prevention and rectification exercises.

It was noted that there appears to be little value in the teacher merely noting the number of errors made by different learners in the class. However, it is suggested that the teacher should attempt to identify the factors which may have caused these errors (including himself). Regarding the use of EFs, the evidence obtained suggests that in order for students to 'generalise' their learning in a given context, they should be provided with associated criteria or problems which are similar. However, for 'transfer' of learning to occur the students should be presented with examples and problems which are different. These measures could also be adopted in formulating diagnostic 'test questions' for EFs so that general confusion and transfer of misunderstanding can both be detected. Nevertheless, the strategy of employing a range of different types of diagnostic 'test questions' was also found to be valuable in such circumstances.

With respect to the actual treatment of EFs the overall teaching approach which was observed to be particularly effective was one which was well-structured but adaptive. It was found that both the special EF diagnostic measures and the 'procedural' framework for EF rectification and exploitation could be readily integrated within the 'remedial area' of

such a flexible teaching scheme. When teaching a subject where there is a rather longitudinal development of learning (i.e. successive 'topics' taught in linear mode) a degree of 'lateralization' is considered desirable in order to prevent EFs arising due to the teaching being undertaken on a rather narrow front. However, in teaching interdisciplinary subjects such as physics and mathematics it was found that the 'zoning' of EFs helped to confine the confusion to the specific discipline in which it had originally developed.

The experience obtained from the main experiment indicates that a major factor concerning the successful treatment of EFs is the learning environment itself. It was discovered that the 'open classroom' strategy is a valuable and effective means of achieving a suitable environment because it converts the classroom into a set of 'learning centres'. A typical approach which was employed in this context was that the students worked out some learning objectives with the teacher (using the measures described in Chapter 4) and then they moved on to the appropriate 'learning centres'. This approach enabled the students to learn at their own pace and have their progress in experimental investigations monitored. Furthermore, during the course of monitoring, students were 'fed' spurious information in order to test their ability to identify and overcome confusion. Finally, it should be pointed out that the strategy also allows the teacher to deal with individual difficulties as and when they are identified, and to 'pace' the more able students.

GENERAL IMPLICATIONS OF INVESTIGATION CONCERNING EFS

There are a number of implications arising from this investigation that impinge on the entire spectrum of learning and which relate to education at all levels. For example, a particularly interesting general implication is that perturbation can have a significant influence on the incidence of EFs. Unfortunately, it appears that it may be difficult to control the level of perturbation or predict its effects in certain instances. Another general observation is that a student's memory of an error can sometimes have a strong influence on the effectiveness of subsequent EF correction measures. The evidence obtained in this context is also in keeping with that of Rabbit and Rogers (op.cit.) who report that responses (E + 1), (E + 2) and so on, made after the commission of an error (E) were not so slow if the learner was required to make an error correction response. Moreover, with respect to the general applications of EFs the findings of this enquiry

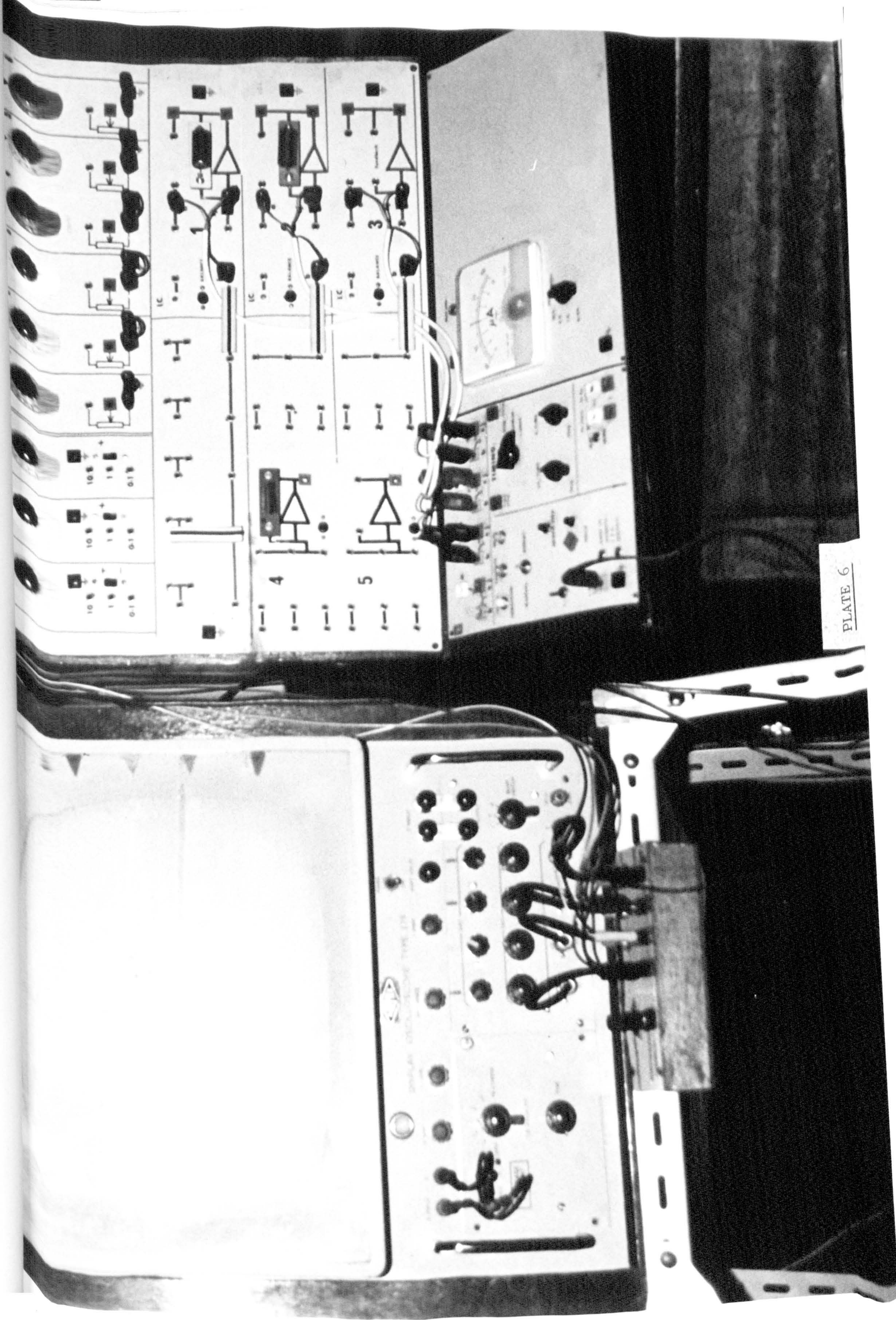

PLATE 6

suggest that they could be employed as 'indicators' of student competence and understanding. In addition, an assessment of students' EFs in a given context could provide the teacher with useful information concerning the effectiveness of particular teaching strategies or instructional material.

In this enquiry, much evidence has been obtained in support of the suggestion that EFs can enable teaching to be both efficient and stimulating. The findings also reinforce the conclusions of Lewis and Pask (op.cit.) in this respect. They point out:

"If it were not for the existence of underlying error factors, teaching would be inordinately long, since mistakes would have to be dealt with in isolation and one at a time".

A further implication regarding the utilization of EFs is that they could possibly be manipulated and used in such a way that the learner is introduced to potential confusion or difficulties in a sequence which best suits his ability and learning style. Similarly, students could be given the opportunity to explore different problem solving strategies in such a way that they progressively learned from their errors. The author has devised a preliminary electronic 'problem solving analogue' (P.S.A.) in an attempt to provide such a facility and this has yielded promising results. (The prototype of this system shown in Plate 6 has a 'simple harmonic motion' problem for a vibrating spring addressed to it.) With this system the student is initially required to reduce the problem to a series of sub-problems, which are simulated on the P.S.A. along with his strategy. The solutions are immediately displayed on the V.D.U. (Visual Display Unit) adjacent to the system and the student is able to explore different strategies without having to readdress the main problem to the P.S.A. Moreover, problem difficulty and constraints are easily changed or modified as the learner progresses.

As a consequence of this investigation it is also considered that there is a case for teaching both the prescriptive and proscriptive approaches to problem solving. However, this may be found to be a somewhat difficult and time consuming task for the teacher. Nevertheless, it could prove to be more fruitful in the long-term if special 'learning packages' are devised which integrate each of these general approaches. This would give the student the opportunity to develop expertise in both EF avoidance and EF correction in the context of problem solving. For example, since 'analogical reasoning' is often employed in problem solving, it would be useful for the student to be made aware of possible errors in this respect (as illustrated on the following page) especially since, as Lewis (op.cit.) observes, the prescriptive approach

alone may not be best suited for this purpose.

The 4 terms of an analogy in the context of problem solving (errors can occur in terms (ii) and (iv)).

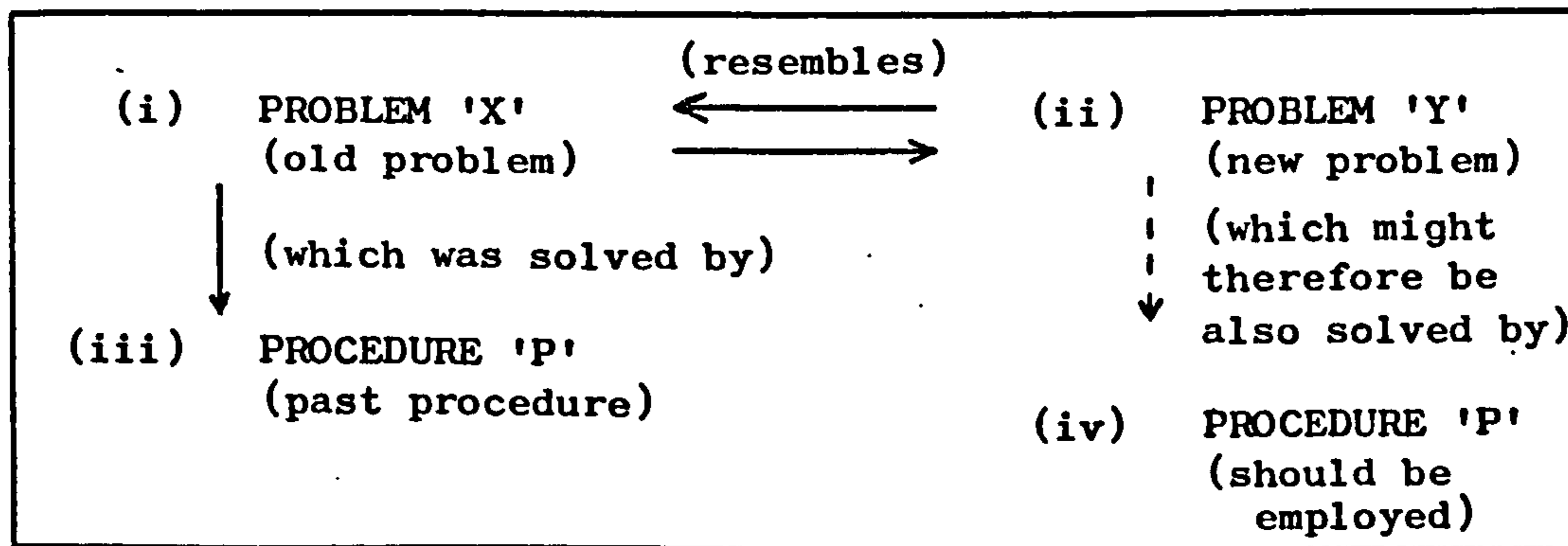

In the context of skill acquisition the implications of this study are that 'structured skills' (such as reading and arithmetic) can be acquired in a way which overcomes some of the possible inhibiting effects of EFs. A general procedure which could be employed in this respect has been suggested by Lewis and Pask (op.cit.). They consider that the skills should be reduced to 'sets' of sub-skills and that special algorithms should then be devised to limit potential EFs which could effect their acquisition. It is interesting that the criteria which they have proposed in this context is similar to that which was employed in the main experiment for EF prevention. Moreover, it has been noted that a similar approach has been successfully adopted in the basic design of certain 'reading laboratories'.

There is reason to suggest, as a consequence of this enquiry, that EFs could also be employed outside the classroom as a kind of unifying factor in 'skills analysis' or in 'time and motion' study. In the former analysis, incidence of errors impinges on 'quality' or work and on safety. In the latter, the incidence of errors impinges on efficiency and motivation. It is interesting to note that Harlow (op.cit.) also observed that experience and efficiency are directly related in the context of learning. Furthermore, Sime, Arblaster and Green (1977) have shown that 'programming errors' can be significantly reduced by the use of a specially structured writing procedure. Moreover, their overall conclusions are in keeping with those presented earlier concerning the reduction of 'random' errors by the careful structuring of tasks.

A final general observation arising from this investigation is that there appears to be a possible relationship between EFs and personality traits or 'behavioural patterns'. This endorses the findings of Leith and Trown (1970) who have reported that learners who were tolerant of ambiguity tended to make fewer errors than those who were less tolerant. In addition, Robertson (op.cit.) has identified a relationship between extraversion and error commission (namely that extraverts tended to make less errors than introverts in the same learning context). These findings suggest that the teacher should take both learning styles and personality differences into account in order to more effectively control the generation of EFs. Similarly, when undertaking the rectification of EFs, it is suggested that these factors should also be acknowledged so that the learners' confusion is not exacerbated by inappropriate remedial teaching. However, these are only tentative suggestions and further investigations must be carried out in this context.

CONCLUDING REMARKS

Prior to undertaking an appraisal of future research issues, there are various comments concerning this investigation which should be presented. Foremost in this respect is the fact that an attempt has been made in this enquiry to provide practical guidelines for the treatment of EFs where no guidelines previously existed. However, only as the result of detailed experimental investigations were many of the latent properties of EFs revealed and much of this study has been exploratory. Nevertheless, the corrigibility of many learner's misunderstandings has been demonstrated and it has been shown that much more could be done concerning the provision of measures to enable EFs to enrich teaching.

With regard to the philosophical theme of this study, it has been shown that there is often more to be gained from the investigation of errors than from the investigation of truth or correctness. Furthermore, there appears to be a case for the provision of a 'philosophy of errors' for teachers which could also play an important role when educationalists are looking for a way of providing some sort of 'order' to curriculum studies. Similarly, if an index of confusion or learning difficulty was formulated, then it could enable both comprehensive and effective advance planning to be undertaken by the teacher. However, more must be discovered concerning the parameters of EFs before this proposal can be implemented.

It should also be pointed out that the statistical analysis of the empirical data obtained in the investigations revealed that the results were all statistically significant. For instance, t-tests were carried out on certain test score data (such as that obtained in the examination of the hypothesis that students in the experimental group would obtain scores in attainment tests which were significantly higher than those of the control group) and the results were found to be highly significant ($p < 0.01$). However, in the context of this enquiry it is the educational significance of the findings that is of particular importance and which requires greater attention in future.

With regard to problem solving, it has been found that EFs can provide a 'window' into a learner's problem solving ability. However, the teacher must appreciate that while a student's approach and understanding may, perhaps, be different from his own, it may not be incorrect. It should also be acknowledged, as Nickel (op.cit.) has emphasised, that there is a need for errors and learning difficulties to be interpreted from the student's rather than the teacher's point of view. (The keeping of a daily 'problem record' by the student has been reported by some investigators to be helpful in this respect). Furthermore, it should not be overlooked that in some problem solving contexts instructional aids and learning materials may be responsible for creating confusion or exacerbating misunderstanding. In such cases 'artificial' EFs could be introduced by the teacher in order to highlight possible sources of difficulty and enable him to prepare the learner so that he can overcome them.

Concerning the rectification of EFs, it has been observed that they should not always be treated in isolation but rather in related groups. One way of achieving this might be for the teacher to attempt to polarise the students' confusion into particular groupings. He could then rectify associated areas or types of confusion rather than deal with random EFs. This should not only prove to be an efficient strategy but also assist in the removal of groups of EFs which overlap different areas of learning (as illustrated by the Venn diagram shown on the following page). Furthermore, if the teacher undertook the rectification of EFs on this basis it could help to increase the degree and rate of learning transfer.

Finally, it is suggested that in the context of EF generation particular attention should be given to this in the early stages of learning since misunderstandings or confusion encountered in the First School can create further confusion and significantly impede subsequent learning progress.

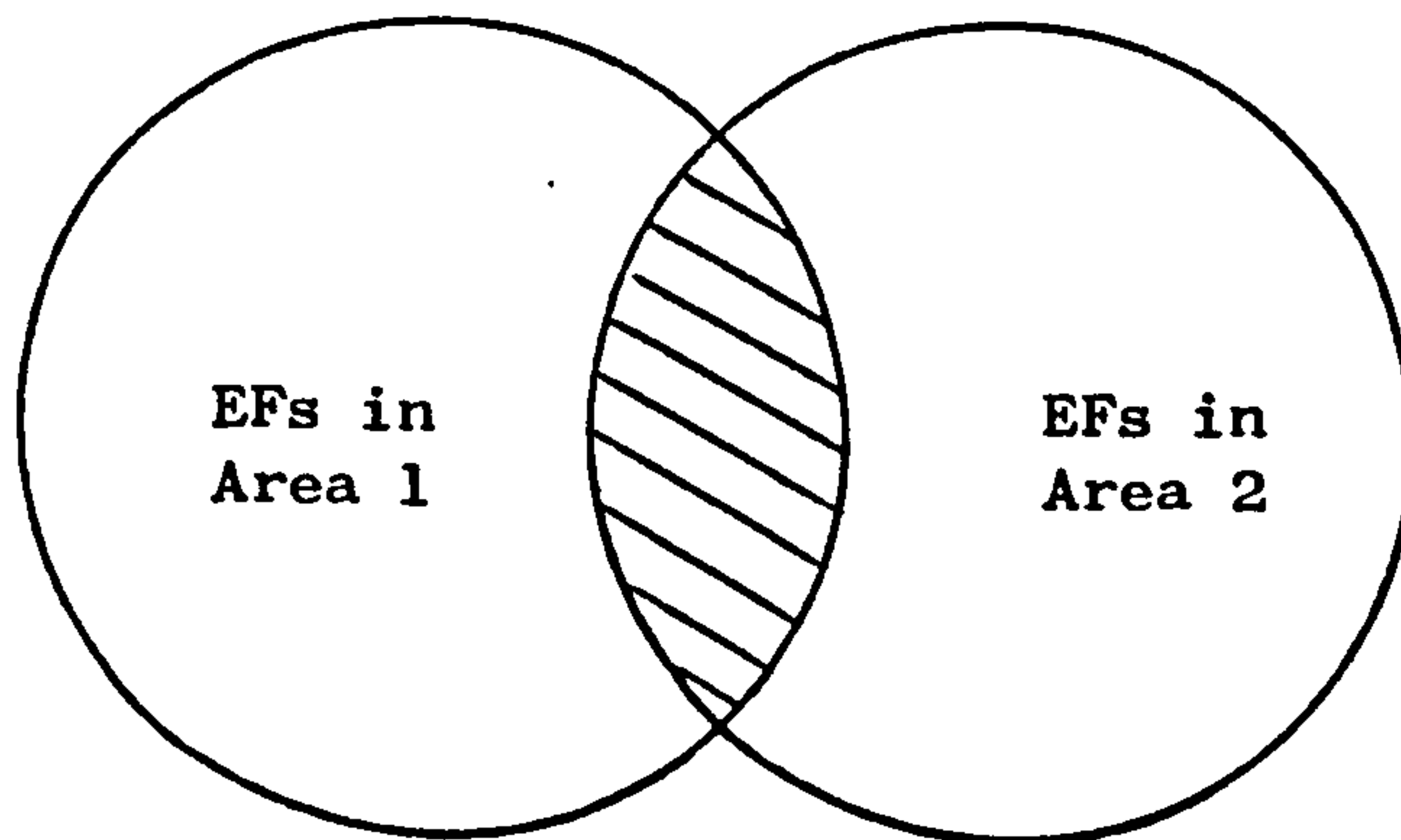

Venn diagram: shaded portion indicates overlap of EFs between Areas 1 and 2

Figure 29

Furthermore, it is considered that when undertaking either syllabus formulation or course design special care should be taken since it appears that both of these may have an influence on the promotion and transfer of confusion. Similarly, it must be noted that learning materials and teaching aids can be instrumental in the generation of EFs. In addition, it may be found that while a particular teaching approach is quite suitable for one group of students it actually promotes confusion with another group. Moreover, the possible generation of EFs outside the classroom must also be taken into account. Perhaps in future, teacher education courses could do more to alert teachers to these problems than they appear to do at present.

ASSESSMENT OF FUTURE DIRECTIONS OF RESEARCH

Introduction

Although this investigation has revealed some important properties of EFs and provided evidence concerning their role in teaching there is much yet to be examined and explored. In this final section an attempt will be made to identify and assess future directions of research in this sphere. This will cover the proposals and theories which have been postulated concerning the nature of EFs and the strategies that have been devised to treat them. Suggestions will also be given regarding the exploration of EFs in contexts other than classroom teaching. Moreover, recommendations will be made concerning the possible order of priority for further research. Comments will subsequently be presented on the future establishment of a 'Unitary theory' of EFs. Finally, the opportunity will be taken in this appraisal for further speculation concerning the potential role of EFs.

(A) MORE IMMEDIATE OBJECTIVES OR TASKS

It is considered that there are certain aspects of the nature and role of EFs which require rather more urgent or immediate investigation than others. Furthermore, it may be found that if these aspects are not dealt with first then this could create difficulties when new or revised theories and practical strategies are introduced. In addition, certain short-term research objectives could, if punctually satisfied, help to provide useful guidelines or foundations for subsequent research in this context. Similarly, if certain empirical data is obtained at appropriate stages during future enquiries it may help to save unnecessary effort or modifications to strategies. In the course of this assessment, various references will be made to some of the findings of this investigation because it is considered that this exercise may assist in revealing ways in which certain proposed future objectives could be more easily satisfied.

EF rectification

There appear to be several short-term or more immediate research issues concerning both the rectification and removal of student EFs. One which is considered to be particularly important and interesting is the investigation of a possible 'self repair mechanism' which appears to occur with respect of certain types of EFs. For instance, it has been observed

that some EFs, if left unrectified, seem to rectify themselves in time. There are two ways that have been observed in which this mechanism seems to function. The first is that the EF actually cancels itself out (perhaps either by chance or because of the presence of another EF). A second way appears to be the consequence of an EF 'metamorphosis' effect with the result that the EF gradually changes into one which has little influence or significant effect on learning. Moreover, if these and other possible mechanisms of self-rectification could be identified then they could perhaps be replicated to promote or assist more effective EF rectification. It may also be possible to synthesise these processes and employ them in situations where the avoidance of EFs is necessary.

A further topic with regard to EF rectification which it is felt requires more immediate attention is the establishment of a system or procedure for quickly discriminating between EFs in terms of the most appropriate order of rectification (i.e. for quickly deciding which EFs 'must' be rectified and which 'should' or 'could' be rectified). At the moment no such rapid general facility exists and so, therefore, on the grounds of expediency, all EFs (with a few exceptions) are recommended to be removed or rectified. This situation could mean that at present, excessive time is being employed for uneconomical EF removal or rectification. Furthermore, it may be found, after further research has been undertaken in this context, that a 'law of diminishing returns' applies in this respect. Therefore, some of the more comprehensive EF rectification exercises which were described earlier may not be completely necessary if time, expenditure and value for effort are taken into account. Finally it is suggested that a study is undertaken in future to obtain evidence regarding the possible benefits which 'selective' EF rectification could provide for the teacher.

Behavioural factors

The findings of this enquiry suggest that it would be valuable to undertake investigations of EFs in relation to personality and behavioural factors. For example, it should prove to be helpful to carry out the study and analysis of an apparent relationship between EFs and student behaviour patterns. This could be particularly instructive since certain overt behavioural phenomena have already been observed to be generally associated with the incidence of errors and confusion by Leith and Trown (op.cit.) and also by Robertson (op.cit.) Furthermore, since the display of 'anxiety' by students in some learning contexts appears to be linked with the incidence of major EFs, it would be most useful to study this more fully in future.

Moreover, under conditions of stress a considerable increase in error frequency has been noted and this should also be examined in greater detail. In addition, an investigation of what Dyer (1977) terms 'erroneous zones', which are quirks of personality that are barriers to effective learning, may help to provide a better insight into the ways which EFs arise.

Philosophical aspects

In many disciplines and areas of learning, the search for truth has always been a paramount objective. As pointed out by Royce (op.cit.), considerable effort is frequently expended in order to defend or support various 'truths' once they have been accepted by so called 'authorities'. This attitude may sometimes have impeded man's progress, and caused him to waste his time and energy. Moreover, the inculcation of this approach has meant that quite often 'errors' are merely discarded without examination (when, in fact, they may not really have been 'errors' at all). It would be a valuable bonus, therefore, if further research in this sphere could bring about a questioning and possible change of this view concerning errors and truths. In addition, further study is required in order to resolve the dilemma concerning the relativity of 'truth' and 'error'. Perhaps means may also be found for the promotion of a greater general awareness of errors and their nature.

There are other factors relating to this aspect which it is considered require further research. Foremost in this respect is the undertaking of a study and assessment of ways in which errors could be employed to assist in the advancement of knowledge. This is because it appears that it can be more valuable or profitable to discover what is wrong (or inconsistent), than what is right (or consistent) in a given context. Furthermore, many 'models' have been devised by scientists and philosophers in order to illustrate and simplify certain phenomena or theories. It is suggested that in some cases these models may have been inappropriate or employed too freely and too literally - with the result that they have created an erroneous impression. Hence, it would be valuable if measures could be devised after undertaking further research, which would help to prevent such problems and control any possible misapplications of this type.

(B) LONG-TERM OR PROTRACTED FUTURE DIRECTIONS OF RESEARCH

Due to both our limited understanding of EFs and their mercurial nature it is difficult to recommend or predict long-term research tasks concerning

their role in teaching. Furthermore, any recommendations which are made may require re-appraisal and modification if new evidence and improved understanding of EFs emerges as a result of the investigations suggested in section 'A'. However, the major goal for future long-term research in this context is quite clear, namely the formulation of a universal theory of EFs in relation to learning and teaching. An important sub-goal in this respect is the provision of a general strategy which could be employed to treat or exploit the EFs of learners in all subjects and at every level of learning.

EF avoidance

The avoidance of EFs is a topic which it is considered requires somewhat protracted future research. This is because measures for EF prevention may actually create EFs if they are not carefully structured and employed. Hence, it will be important to explore this topic thoroughly and carefully in future. Similarly, further detailed investigation of the use of algorithms in this context is recommended since the results of this enquiry suggest that algorithms can be very effective in helping to prevent EFs. It should also prove to be valuable to undertake an extensive investigation of EF prognosis since this could provide useful information relating to the provision of EF avoidance measures.

EFs and learner motivation

Although a relationship has been identified between student learning motivation and EFs, this has not been explored in any depth. It is suggested that a longitudinal study of this relationship is undertaken so that a comprehensive picture can be obtained. This knowledge could prove useful in enabling EFs to be more fully exploited to aid learning in future. Furthermore, such a study may provide information which would help in the formulation of systems of instruction in which EFs are manipulated by the teacher in order to improve learner motivation. It would also be valuable if this enquiry included an investigation of individual learning styles and the incidence of EFs since little is known in this respect.

EFs and problem solving

The question as to why some learners appear to be more prone to errors and confusion than others during problem solving has yet to be examined. The author considers that the theories of Pask (op.cit.) concerning the

process of 'internalised conversation' during problem solving could perhaps provide some possible explanations for this. It could be found that if a learner has his conversational 'dialogue' in a particular problem solving context made up from what may be described as an 'erroneous vocabulary', then his 'conversations' would consistently have an incorrect basis. This confusion would also be transferred when his 'conversations' were 'externalised'. Furthermore, since the learner may hold new 'conversations' using the same basic 'erroneous vocabulary', it could be found that this is the reason why he continues to perform badly (and hence appears to be more prone to confusion and errors than others). However, it must not be assumed that Pask's 'conversation theory' is an exclusive theory in this respect, and therefore, other possible explanations should also be explored in any future research in this sphere.

Alternative EF treatment measures

It has been reported that EF treatments are often more successful if they are carried out soon after the EF has been detected and identified. However, in the case of 'correspondence' students and so on, these conditions may be sometimes difficult to satisfy. It could thus be valuable in future to examine the possibility of using 'phone-in' techniques (aided by radio or television) and other measures in order to reduce the time-lag in this respect. Furthermore, it should be pointed out that the use of 'teaching machines' for EF treatment has still to be fully investigated. It may also be profitable to explore the suggestion of Lewis and Pask (op.cit.), that if teaching machines actually recorded the errors that are made by a learner, they could later be analysed so that a personalised EF rectification procedure could be provided. Strevens (op.cit.) also has made some valuable suggestions, with regard to the design of teaching machines for use with students who have language learning difficulties, which require further study. Finally, it is recommended that further research and development is undertaken on the basis advocated by Brown and Burton (1975) who have devised a tutorial 'reasoning' machine (SOPHIE) in an attempt to treat the errors and confusion of students learning science topics.

It is hoped that the products of this research, namely the theoretical ideas, observations and empirical evidence will help to stimulate other workers into exploring this field.

APPENDIX 1

Summary of Gilbert's ideas concerning improving human performance

(T. Gilbert : 1977)

In Gilbert's (op.cit.) view, it is possible to engineer 'worthy performance' from a candidate in a variety of educational and occupational contexts. He defines what he calls a P.I.P. (potential for improving performance) as the ratio of an 'exemplary' performance to a 'typical' performance. Gilbert suggests that this ratio tells us two things,

- i) how much competence a person has.
- ii) how much potential for improved performance a person has.

He considers that a 'master performer' or 'exemplar' would have a P.I.P. of almost 1.00 and a very poor performer could have a P.I.P. of approximately 20.00 to 40.00. However, he points out that, as a P.I.P. approaches 1.10 it becomes very much harder to improve than if it were 11.00. It is particularly significant in the context of this investigation that Gilbert has found that a large P.I.P. usually requires only a small remedial exercise to considerably reduce it - such as the rectification of underlying confusion (i.e. the removal of basic EFs).

It is noteworthy with respect to this study that Gilbert suggests that a P.I.P. is a vector quantity. Moreover, he considers that the 'performance engineer' (i.e. the teacher in the learning context) is an analyser of human incompetence (or error) and its causes. In this respect Gilbert provides an apt quotation by B.F. Skinner:

"The animal is always right, only the animal trainer can fail".

APPENDIX 2

Observations concerning the theory of 'Structural learning'

(A) Structural learning. (J. Scandura : 1976)

Scandura (op.cit.) proposes that knowledge can be characterised by a finite 'set' of rules, and that, by allowing rules to operate on other rules in the 'set', new rules can be generated. He suggests that these new rules could be expanded and modified to account for changes in knowledge. This is a similar strategy to that which the author has advocated with respect to measures for treating EFs in the context of learning. Concerning teaching by the use of special rules Scandura has developed a 'hierarchical' system which has been mainly investigated in the context of teaching arithmetic.

In this system the rule (algorithm) to be taught is broken down into sub-rules and then each sub-rule is finally reduced to the elemental stage where the learner can start assimilating it. Moreover, his overall strategy for identifying basic learning difficulties is not unlike that which the author has developed for EF diagnosis (i.e. starting with the group of difficulties (errors) and breaking these down until the underlying difficulty and hence its cause, is identified).

(B) Theories of 'proof' (J. Corcoran : 1976)

The interesting aspects of these theories in the context of this enquiry are the relations of the 'correctness' of proofs (e.g. in mathematics, science and sociology) and the 'interpretations' of these proofs. Corcoran (op.cit.) points out that correct (valid) proofs can be constructed from 'rules of inference', and there is a danger that these rules may be applied by the student without his really understanding them. There is thus clearly a need for certain safeguards to be provided by the teacher in this respect.

Corcoran proposes that the formulation of theories of proof should be undertaken in a logical sequence of axioms. What is also interesting in relation to this investigation is that he suggests that in providing a 'proof' the teacher must ensure that its validity and form are understood by the

student. This is because a student could make a considerable number of errors due to misunderstanding a proof or not employing it in an appropriate context.

APPENDIX 3

Electronic Feedback Teaching System

The System

Part of this system is shown in figure 28 below (the actual system can have 16 or 20 Student Response Units). It can be employed, for example, with 'multiple-choice' test questions (usually with four distractors) and these are presented to the students on written sheets or on an overhead projector. Each student responds by pressing a button labelled A, B, C or D on his Response Unit. The lamp on the student's unit lights up when a correct choice is made. Alternatively, 'true/false' questions may be presented where button 'A' is pressed for 'true' and button 'B' for 'false'.

The students' responses are monitored on the Lecturer's Console Unit which also has facilities for pre-selecting the correct answer so that student responses are automatically confirmed, and for cancelling the responses monitored, in readiness for the next question.

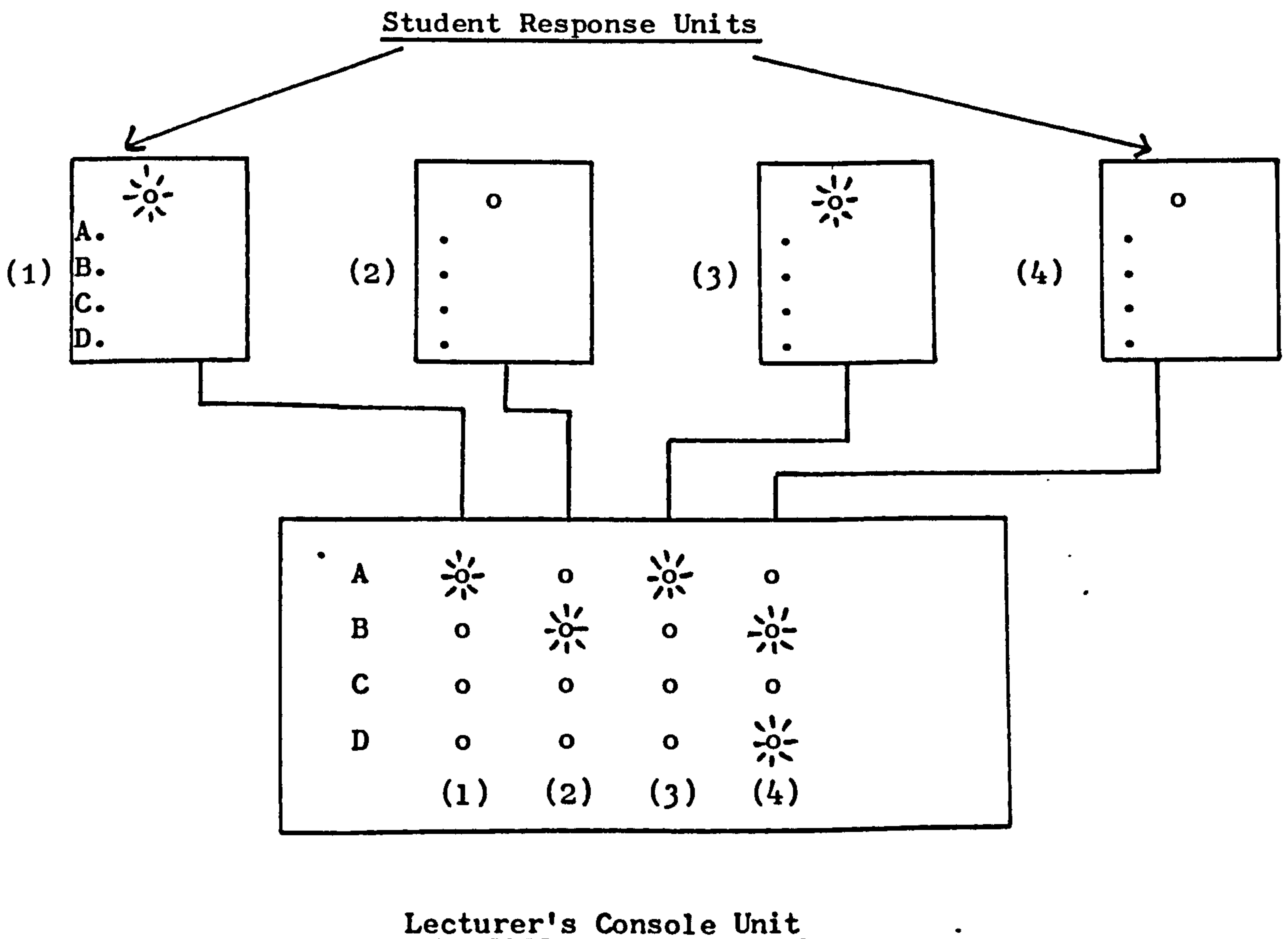

Figure 28

In the test situation shown in Figure 28, 'A' is correct and two students (1 and 3) have had their responses confirmed. One student (2) has chosen 'B' and the fourth student is displaying a trial and error strategy as he has already had one button push too many.

Some Uses of the system

- (i) To devise optimum learning sequences by monitoring student responses during the course of a lecture.
- (ii) To measure the effectiveness of a learning sequence by administering pre and post tests.
- (iii) To make rapid appraisal of the entering behaviour of students beginning courses of study.
- (iv) To reduce the response inhibitions that many mature students normally display in a conventional classroom situation (by making available a private communication link between student and lecturer).

General Observations on the Electronic Feedback Teaching System

- (a) The system demands a precise statement of objectives for each lecture with attendant advantages to both lecturer and student.
- (b) Teacher failure is instantly revealed by analysing student feedback, and remedial action can be undertaken immediately.
- (c) The students are active participants in the learning episode.
- (d) The lecturer-student relationship is enhanced by virtue of the frequency of communication between the lecturer and each student.
- (e) The present system permits the monitoring of up to 20 students at one time, but this can be extended further.
- (f) The system shown in Figure 28 is a 'built in' one but a mobile feedback teaching system is shown in Plate 1 (see Chapter 1). In either case the same basic units are employed.
- (g) The time taken to convert the room for feedback use is about 2 minutes in the case of the fitted system and about 2½ minutes for the mobile version.
- (h) 'Marking time' for testing is reduced to a minimum and student responses are monitored instantly. Electromagnetic counters enable scores to be corrected for guessing and for omissions.

APPENDIX 4

Additional Information: concerning Pilot experiment 1 (Reported in Chapter 3)

After the group of students involved in this experiment had taken their final physics examinations (at the end of their First Year course in 1976) it was decided to see if their examination results were different from those of students in previous years of this same course. Two main aspects were examined when analysing their examination papers. Firstly, the students' performance was assessed in answering questions on the electrical topics which had been the subject of this investigation. The second aspect which was examined in detail was their overall performance in the examination - to discover how this compared to that of previous groups of First Year Automobile Engineering students.

Examination Results

The results shown in Table 12 reveal that, in answering the examination questions on the 3 electrical topics which were dealt with in the pilot investigation, no student in the entire group obtained less than 75% of the total marks for any of these questions. In fact, as can be seen from the table, the mean score for the whole group in this section was 85%. The results thus indicate that the long-term effects of the diagnostic and EFs rectification strategies were satisfactorily maintained. Reference to the results for the previous three years, which are also given in the table, shows that the mean scores were only 60% (approx.) and a number of students obtained marks of 25% (or less).

Analysis of results for examination questions on Current Electricity topics

(Comparison of final Physics Examination results 1973-76)

| Year | Topic Number | No. of students in group | No. attempting question on topic | % Correct | Mean % mark | Minimum % mark |
|------|--------------|--------------------------|----------------------------------|------------------|-------------|----------------|
| 1973 | <u>1</u> | 18 | 9 | 50 | 60 | 26 |
| 1974 | | 17 | 8 | 47 | 60 | 24 |
| 1975 | | 16 | 5 | 50 | 59 | 24 |
| 1976 | | 17 | 16 | 100 ¹ | 86 | 76 |
| 1973 | <u>2</u> | 18 | 8 | 45 | 58 | 25 |
| 1974 | | 17 | 8 | 44 | 56 | 24 |
| 1975 | | 16 | 7 | 43 | 58 | 25 |
| 1976 | | 17 | 14 | 86 ² | 85 | 75 |
| 1973 | <u>3</u> | 18 | 8 | 44 | 58 | 24 |
| 1974 | | 17 | 7 | 44 | 56 | 22 |
| 1975 | | 16 | 6 | 41 | 57 | 24 |
| 1976 | | 17 | 14 | 86 ² | 84 | 75 |

Table 12

1. Although their answers were basically correct, five students were not awarded maximum marks due to rather incomplete explanations.
2. Three students made small mistakes with these questions, but showed that they did understand the topics correctly.

To see if this particular group of students was generally more able than previous ones their overall examination performance was also studied. This was found not to be the case as shown in Table 13. As can be seen from this table, in comparison to the previous three groups, their

performance in the examination as a whole was nearly the same as two of the previous groups, and not quite as good as the third. This indicates the need for the special EF treatment measures to be extended to all the other topics in this course. It is interesting to note that this group also obtained significantly higher marks in their Second Year (in 1977) when answering more advanced questions on the electrical topics, than the previous groups.

Analysis of Student Performance with all other questions on Physics Examination Papers

| Year | Number in group | Mean % correct of all <u>other</u> examination questions attempted | Mean % marks | Minimum % marks |
|------|-----------------|--|--------------|-----------------|
| 1973 | 18 | 60 | 58 | 29 |
| 1974 | 17 | 57 | 56 | 27 |
| 1975 | 16 | 59 | 57 | 29 |
| 1976 | 17 | 57 | 57 | 28 |

Table 13

APPENDIX 5

BASIC DETAILS OF PILOT STUDY 2 (Reported in Chapter 3)

In this second pilot investigation the EFs associated with the learning of certain topics in 'atomic physics' and radioactivity were observed in relation to three groups of students who were studying these topics as part of their courses in physics. Two of the groups ('A' and 'B') were parallel groups taking a 'Science Laboratory Technicians' Course (one of which, group 'B', was designated as the 'control group') and the third ('C') group were First Year 'Higher National Diploma' (Engineering) students of comparable level and backgrounds to the others.

SUMMARY OF EXPERIMENT

There were a number of reasons why these particular groups of students were selected for study. Foremost in this respect was the fact that there was a requirement on the courses in question for improving both the levels of attainment and degree of success of the students. It was felt that this could perhaps be achieved by the employment of EF diagnosis and treatment strategies. Furthermore, there was a need for the provision of reliable error prevention measures concerning 'radioactivity' for these students since certain errors could lead to actual danger, and health hazards.

It was intended that this investigation would also provide an opportunity for observing possible relations between EFs and 'patterns' of confusion in the same topics against the background of different groups of students. Since two of the groups were essentially parallel and identical, then some direct comparisons of EF diagnostic procedures and their results could be made. These observations were subsequently assessed and contrasted with the performance of the third group of students.

STUDENT DATA

| | | |
|-------------------|---|-------------|
| Number in Groups: | Group 'A' | 10 students |
| | Group 'B' | 10 students |
| | Group 'C' | 15 students |
| Average Age: | 18 years | |
| Basic Attainment: | ONC 'Technology' and/or GEC 'O' level physics, mathematics etc. | |

Year of Course: All 3 Groups were in 1st
Year Courses

Background: All the students were British
and male (except for 1 female
in Group 'A')

Summary of Teaching Approach and Learning Situation

The three groups of students were all required to study various topics in 'atomic physics' and radioactivity to approximately the same level, and under similar teaching conditions. The approach employed in the teaching of these three groups was essentially the same, namely a series of lecture/demonstrations supported by appropriate student test experiments, test questions and numerical problems. At this particular level and stage the emphasis was on an applied rather than theoretical appreciation of 'atomic physics' and radioactivity. The time allowed per week for the study of physics for each of the groups was $2\frac{1}{2}$ hours (taken as a $1\frac{1}{2}$ hour period and a separate 1 hour period). The students studied these topics for about 6 weeks in their 1st Year course. All teaching was undertaken in modern well-equipped lecture rooms/laboratories.

All the instruction and testing was undertaken by the investigator and monitored/checked by an independent observer.

RESULTS

EF DIAGNOSIS DATA

Atomic Physics

| Topic Number | Total Number of Errors | Number of students with Common Error Type | Number of students with Common Error Type |
|--------------|------------------------|--|---|
| 1 | <u>24</u> | 15 <u>Group totals</u> 'A' 5 'B' 4 'C' 6 | 9 <u>Group totals</u> 'A' 4 'B' 2 'C' 3 |
| 2 | <u>24</u> | 15 <u>Group totals</u> 'A' 5 'B' 4 'C' 6 | 9 <u>Group totals</u> 'A' 4 'B' 2 'C' 3 |
| 3 | <u>23</u> | 15 <u>Group totals</u> 'A' 5 'B' 4 'C' 6 | 8 <u>Group totals</u> 'A' 3 'B' 2 'C' 3 |

TABLE 14

EF DIAGNOSIS DATA

Radioactivity

| Topic Number | Total Number of Errors | Number of students with Common Error Type | Number of students with Common Error Type |
|--------------|------------------------|--|---|
| 1 | <u>22</u> | 15 <u>Group totals</u> 'A' 5 'B' 4 'C' 6 | 7 <u>Group totals</u> 'A' 2 'B' 2 'C' 3 |
| 2 | <u>22</u> | 15 <u>Group totals</u> 'A' 5 'B' 4 'C' 6 | 7 <u>Group totals</u> 'A' 2 'B' 2 'C' 3 |
| 3 | 21 | 15 <u>Group totals</u> 'A' 5 'B' 4 'C' 6 | 6 <u>Group totals</u> 'A' 2 'B' 2 'C' 2 |

TABLE 15

COMMENTS ON THE RESULTS

As shown in Tables 14 and 15, common 'patterns' of errors were identified for each topic. For example, with Topic 1 (on radioactivity) 50% of SLT group 'A', 40% of SLT group 'B' and 40% of the HND group displayed the same basic pattern of confusion. This evidence indicates that there is possibly a group of 'common' EFs associated with this subject. It would be useful to undertake further investigations to explore this possibility more fully in future.

BIBLIOGRAPHY

- BECKER, J.T. (1970) Spatial Orientation. Perceptual and Motor Skills. Vol. 31, No. 3, 943-6.
- BRANN, C. (1972) Dictation as an Aural Test: An Essay in Error Analysis. Int. Rev. Applied Linguistics. Vol. 10, Pt. 4, 361-8.
- BROWN, J.S. and BURTON, R.R. (1975) Representation and Understanding. In Bobrow, D.G. and Collins, A. (Ed.), Cognitive Science: New York: Academic Press.
- BROWN, J.S. and BURTON, R.R. (1977) Diagnostic Models for Procedural bugs in Mathematics: Cambridge, Mass: Bolt Beranck and Newman.
- CORCORAN, J. (1976) The nature of a correct theory of proof. J. Struct. Learning. Vol. 5, 195-223.
- CORDER, S.P. (1962) The significance of learning errors. I.R.A.L. 8, 161-170.
- COTTERELL, G. (1971) Helping the bad speller. Reading: Vol. 5, No. 3, 2-7.
- DESCARTES, R. (1644) Principia Philosophiae. Amsterdam.
- DE GROOT, A.D. (1965) Thought and choice in chess. The Hague: Mouton.
- DYER, W.W. (1977) Your erroneous zones. London: Sphere.
- FISCHER, D.H. (1971) Historian's fallacies. London: Routledge and Kegan Paul.
- FREUD, S. (1917) Introductory lectures on Psycho-Analysis. Vienna.
- GAGNE, R.M. (1970) The conditions of learning. London: Holt, Rinehart and Winston.
- GEARHART, B.R. (1973) Learning difficulties: educational strategies. New York: Academic Press.
- GILBERT, T.F. (1962) Mathematics : The Technology of Education. J. of Mathetics . Vol. 1, No. 1, 7-73.
- GILBERT, T.F. (1977) Human Competence: Engineering Worthy Performance New York: McGraw-Hill.
- HALFF, H.M. (1975) Stimulus preservation after successes and errors in concept identification. Amer. J. of Psychol. 30, 164-7.
- HAMMARBERG, B. (1974) The insufficiency of error analysis. Int. J. of App. Linguistics in Lang. Teaching. Vol. 12, Pt. 3, 185-92.

- HARLOW, H.F. (1949) The Formation of Learning Sets. Psychol. Review. Vol. 58, 51-65.
- HARLOW, H.F. (1959) Learning set and error factor theory. In Koch, S. (Ed.), 'Psychology: A study of science'. Vol. 2, Study 1, New York: McGraw-Hill.
- HARLOW, H.F. (1975) Analysis of discrimination learning by monkeys. In Levine, M. (Ed.), A cognitive theory of learning. New Jersey: Lawrence Erlbaum Assoc.
- HILGARD, E.R. and MARQUIS, J. (1964) Conditioning and learning. New York: Appleton Century Crofts (2nd Ed.).
- HILGARD, E.R. and BOWER, G.H. (1975) Theories of learning. New York: Prentice Hall.
- HIRSCH, E.D. (1967) Validity in interpretation. Yale Univ. Press.
- KALDOR, S. and SHELL, R. (1970) Multilingual Speakers' problems in decoding a second language. Linguistic Communications. Vol. 2, 2-23.
- KELLEHER, R.T. (1965) Operant Conditioning. In Schrier, M. et al. (Ed.), Behaviour of non human primates. New York: Academic Press.
- KELLERMAN, E. (1974) Elicitation, Lateralisation and Error Analysis. York Papers in Linguistics. No. 4, 162-89.
- LANDA, L.N. (1974) Algorithmization in Learning and Instruction. Moscow.
- LEE, W.R. (1976) Encouraging and discouraging Mistakes. Paper for: Int. Assoc. Teachers of English. St. Malo, France.
- LEITH, G.O.M. and TROWN, E.A. (1970) Influence of Personality and task condition on learning transfer. Paper for Univ. of Birmingham. School of Educ.
- LEVINE, M. and FASNACHT, R. (1974) Token rewards may lead to token learning. Am. J. of Psychol. 29, 816-20.
- LEVINE, M.A. (1975) A cognitive theory of learning. New York: Lawrence Erlbaum Assoc.
- LEWIS, B.N. (1965) The need for research into error factors. Paper for Cambridge Consultants Ltd.
- LEWIS, B.N. and PASK, G. (1965) The theory and practice of adaptive teaching systems. In Glaser, R. (Ed.), Teaching machines and programmed learning Vol. II Data and directions. Nat. Ed. Assoc. of America.
- LEWIS, B.N. and COOK, J.A. (1969) Toward a theory of telling. Int. J. Man-Machine Studies, Vol. 1, 129-176.
- LOCKE, J. (1690) Essay Concerning Human Understanding. London.

- MAGEE, B. (1974) Popper. London: Fontana.
- MEIER, J.H. (1976) Developmental and learning disabilities. Baltimore. University Park Press.
- MILES, R.C. (1965) Discrimination - learning sets. In Schrier, M. et. al. (Ed.), Behaviour of non-human primates. New York: Academic Press.
- MOULY, G.J. (1971) Readings in Educational Psychology. New York. Holt Rinehart and Winston.
- NICKEL, G. (1971) Variables in a hierarchy of difficulty. Working Papers in Linguistics: Vol. 3, No. 4, 185-194.
- OLSSON, M. (1972) Intelligibility: A study of errors and their importance. Res. Bull. 12. Gothenberg School of Ed. Sweden.
- PASK, G. (1975) Conversation, Cognition and Learning. Amsterdam: Elsevier.
- PASK, G. (1976) Conversational techniques in the study and practice of Education. Brit. J. Ed. Psychol. Vol. 46, Pt. 1, 12-25.
- PIAGET, J. (1928) The Language and thought of the child. London: Routledge and Kegan Paul (1971).
- PICKTHORNE, S.M. (1976) An Investigation into the relation between Language acquisition and the state of Infantile Autism. Unpub. Thesis: Univ. of Birmingham.
- POLYA, G. (1967) How to solve it. Anchor: 2nd. Ed.
- POPPER, K. (1972) Conjectures and refutations: the growth of scientific knowledge. London: Routledge and Kegan Paul. (4th Ed.).
- RABBIT, P. and ROGERS, B. (1977) What does a man do after he makes an error? An analysis of response programming. Res. Paper: Dept. Exptal Psychol. Oxford.
- REITMAN, W.R. (1965) Cognition and thought. New York: Wiley.
- ROBERTSON, I.T. (1976) Learning and Personality. Ph.D. Thesis, Open University.
- ROYCE, J. (1885) The religious aspect of philosophy. Boston: Houghton Mifflin Co.
- RUSSELL, M. (1970) Assorted Programmed Texts for Learning Systems Limited.
- SCANDURA, J. (1976) Structural learning: definitional foundations. J. Struct. Learning. Vol. 3, 254-273.
- ¹SCHRIER, M., HARLOW, H.F. and STOLLNITZ, F. (1965) Behaviour of non human Primates. New York: Academic Press.

1 Additional references not listed here are all contained in this work.

- SIME, M.E., ARBLASTER, A.T. and GREEN, T.R.G. (1977) Reducing programming errors in nested conditionals by prescribing a writing procedure. Int. J. Man-Machine Studies. Vol. 9, 119-126.
- SKINNER, B.F. (1965) Science and human behaviour. New York: Collier-Macmillan.
- SKINNER, B.F. (1966) The behaviour of organisms: New York: Appleton Century Crofts.
- SMITH, C.W. (1969) A study of constant errors in subtraction. Ph.D. Thesis. Wayne State Univ., America, Univ. Microfilms.
- SMITH, W.I. and MOORE, J.W. (1965) Learning sets in programmed instruction. Final Report for Bucknell Univ. Lewisburg, P.A. America.
- SPECTOR, S. (1972) Patterns of difficulty in English bilingual children. M.A. Thesis. Sacramento State Coll: America.
- STONES, E. (1968) Learning and teaching. New York: Wiley.
- STREVENS, P. (1971) Two ways of looking at error analysis. Zielsprache Deutsch, Vol. 1, 1-6
- TERRACE, H.S. (1963) Discrimination Learning with and without errors. J. Exp. Animal Behav. Vol. 6, 1-27.
- TERRACE, H.S. (1963) Discrimination learning with and without errors. J. Exp. Animal Behav. Vol. 8, 223-232
- TERRACE, H.S. (1963) Errorless Discrimination learning. Science. Vol. 140, 318-19.
- TERRACE, H.S. (1964) Wavelength Generalisation. Science. Vol. 144, 78-80.
- THORNDIKE, E.L. (1895) Animal Intelligence. New York: Macmillan.
- TRAN-THI-CHAU (1975) Error analysis contrastive analysis, and students' perception. Int. Rev. of App. Linguistics. Vol. 13, Pt. 2, 119-143.
- VAN HIELE, P.M. (1974) System Separation and Transfer. Ed. Studs in Maths. Vol. 5, 34-38.
-
- WALLEN, N.E. and TRAVERS, R.M.W. (1967) In Gage, N.L. (Ed.) Handbook of Research on Teaching. Chicago: Rand McNally and Co.
-
- WHEELER, D.H. (1977) Notes on mathematics for children. A.T.M: Cambridge Univ. Press.
- WING, L. (1975) Autistic Children. London: Constable.
- WOOD, E.R. (1959) Subject dissabilities: In Skinner, C.E. (Ed.), Educational Psychology. New York: Staples Press.