

APPLYING LOOP-MEDIATED ISOTHERMAL AMPLIFICATION (LAMP) IN THE DIAGNOSIS OF MALARIA, LEISHMANIASIS AND TRYPANOSOMIASIS AS POINT-OF-CARE TESTS (POCTs)

M. Auxiliadora Dea-Ayuela^{1,*}, Cristina Galiana-Roselló^{1,2}, Aikaterini Lalatsa³, Dolores R. Serrano^{4,5}

¹Departamento de Farmacia, Facultad de Ciencias de la Salud, Universidad Cardenal Herrera-CEU, Moncada, Valencia, 46113, Spain.

²Department of Inorganic Chemistry, Institute for Molecular Science, University of Valencia, Catedrático Jose Beltran 2, 46980 Paterna, Spain

³School of Pharmacy and Biomedical Sciences, University of Portsmouth, St. Michael's Building, White Swan Road, Portsmouth PO1 2DT, U.K.

⁴Departamento de Farmacia y Tecnología Farmacéutica, Facultad de Farmacia, Universidad Complutense de Madrid, Plaza Ramón y Cajal s/n, Madrid, 28040, Spain.

⁵Instituto Universitario de Farmacia Industrial. Facultad de Farmacia. Universidad Complutense de Madrid, 28040, Madrid, Spain

*Corresponding author:

Prof María Auxiliadora Dea-Ayuela
Departamento de Farmacia, Facultad de Ciencias de la Salud
Universidad Cardenal Herrera-CEU, Moncada,
Valencia, 46113, Spain
Email: mdea@uchceu.es; mda_3000@yahoo.es
Tel: 96 136 90 00 | Ext. 64316
Fax: +34 961 395 272

ABSTRACT

One of the main objectives of the WHO is controlling transmission of parasitic protozoa vector-borne diseases. A quick and precise diagnosis is critical in selecting the optimal therapeutic regime that avoids unnecessary treatments and the emergence of resistance. Molecular assays based on loop-mediated isothermal amplification (LAMP) techniques are a good alternative to light microscopy and antigen-based rapid diagnostic tests in developing countries, since they allow for a large amount of genetic material generated from a few copies of DNA, and use primers that lead to high sensitivity and specificity, while the amplification process can be performed in isothermal conditions without the need of sophisticated equipment to interpret the results. In this review, the main advances in the development of LAMP assays for the diagnosis of malaria, leishmaniasis and Chagas' disease are discussed as well as the feasibility of their implementation in developing countries and use as point- of-care diagnostic tests.

KEYWORDS

Loop-mediated isothermal amplification (LAMP), leishmaniasis, American trypanosomiasis, Chagas disease, malaria, diagnostic tools, primers, point-of care tests.

GRAPHICAL ABSTRACT

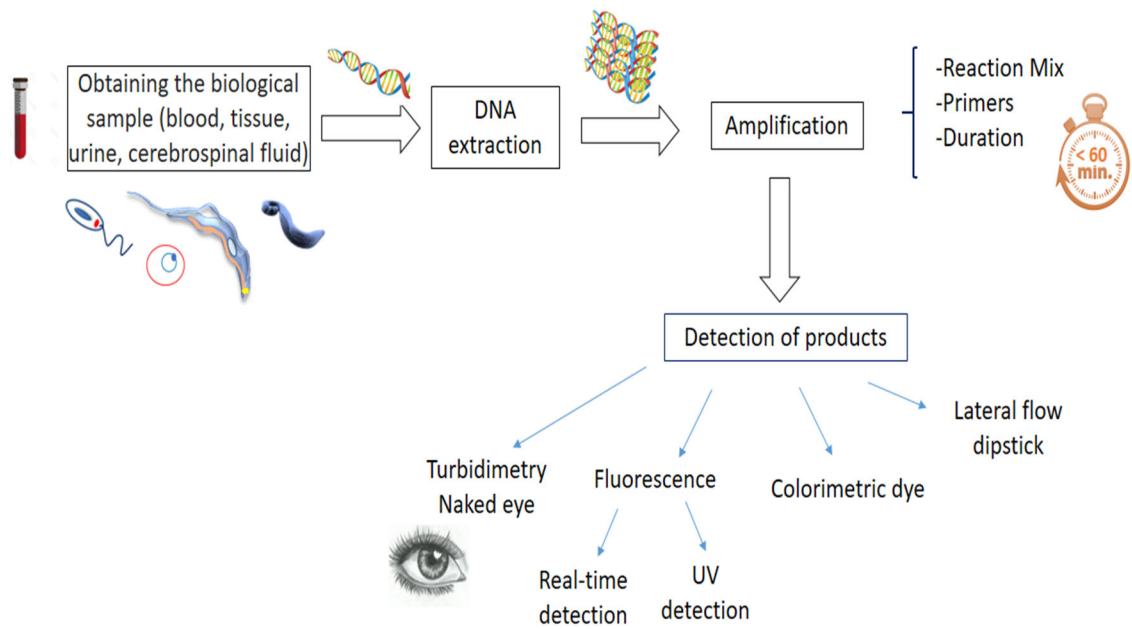

Rosenblatt et al. 2012). For this reason, it is often necessary to use other diagnostic methods including serological assays and more recently, molecular-based assays.

In developed countries, novel techniques are commercially available allowing a faster, highly specific and sensitive diagnosis for a wide range of parasites such as the Falcon assay screening ELISA test (FAST-ELISA), Dot-ELISA, rapid antigen detection system (RDTS), luciferase immunoprecipitation system (LIPS), loop-mediated isothermal amplification (LAMP), and diverse types of polymerase chain reaction (PCR) as nested PCR, multiplex PCR or Luminex (Ndao 2009). A comparison of all these techniques is illustrated in Table 1.

Table 1. Techniques commercially available for highly specific and sensitive diagnosis for a wide range of parasites. Adapted from: (Han 2013, WHO 2018).

	Microscopy	Rapid diagnostic tests*	PCR Nested	PCR Real-time	PCR Multiplex	LAMP
Principle	Morphology-based	Immunological-based	Molecular based	Molecular based (DNA)	Molecular based (DNA or RNA)	Molecular based (DNA or RNA)
Specificity (identification of species)	Possible	Possible	Possible	Possible	Possible	Possible
Quantification	Yes Gold standard	No	No	Yes	Yes	Yes
Nucleic acids (NA) purification	Non required	Non required	Required	Required	Required	Non required
Temperature for NA amplification (°C)	Non required	Non required	40-98	40	98	60-65
Time (h)	0.5-1	0.3	4	2	2	0.5–1
Detection method	Eye	Eye	Agarose Gel	Graph	Agarose Gel/ Graph	Naked eye/turbidimetry/ Colorimetry/fluorometry/ graph
Risk of contamination	No	No	Low	Low	Low	Potentially High
Personnel Skill level	High	Low	Medium/ High	Medium	Medium	Medium/Low
Equipment	Microscopy	Not required	Thermocycler	Thermocycler	Thermocycler	Thermal block/ Water bath
Cost	Low	Low/middle	High	High	High	Medium

*In the case of Malaria, there are 200 different commercial kits. In 2007, FIND and WHO began implementation of a global RDT evaluation programme just recently completed.

For a test to be uptaken by developing countries, the WHO indicated that a diagnostic test should be Affordable, Sensitive, Specific, User-friendly (simple to perform in a few steps with minimal training), Robust and rapid, Equipment free, and Deliverable to the end user (also known with the acronym ASSURED) (Mabey, Peeling et al. 2004). Based on these principles, several techniques have been developed in order to serve as point-of-care tests (POCT) aimed to be performed "in or near the patient care site". The best known are the rapid diagnostic test (RDT), which are lateral flow immuno-chromatographic tests. These systems are based on the use of a biological sample such as blood or urine in which a specific biomarker can be found (e.g. antigens, antibodies or oligonucleotides). These biomarkers can migrate by capillarity through a nitro-cellulose membrane on which specific bio-recognition and detection components are immobilized. However, RDTs have some limitations in terms of sensitivity and specificity due to cross-reactions with other parasites and similar proteins in the blood (Momcilovic, Cantacessi et al. 2018). Recently, nucleic acid (DNA) amplification tests (targeting pathogen biomarkers) have been developed with good sensitivity and specificity to be used with reduced infrastructure, and simple and fast handling. The best known of these techniques is LAMP (Njiru 2012) which will be described in more detail below.

2. LOOP-MEDIATED ISOTHERMAL AMPLIFICATION (LAMP): FROM ITS ORIGIN TO ITS APPLICATION AS POCT

The loop-mediated isothermal amplification of DNA (LAMP) is a molecular technique that detects specific genes in the genome of a target parasite. This method is similar to conventional PCR in which DNA is also amplified. However, LAMP rapidly amplifies target DNA with high specificity and efficiency under isothermal conditions over a range of 60-65°C, using a strand displacement reaction (Notomi, Okayama et al. 2000). The auto-cycling strand displacement DNA synthesis is performed by a Bst (*Bacillus stearothermophilus*) DNA polymerase. This technique uses a DNA polymerase and a set of designed primers (originally 4 - named F3 and FIP forward primers; B3c and BIP reverse primers) that recognize a total of six distinct sites on the target DNA (Notomi, Okayama et al. 2000, Nagamine, Hase et al. 2002). Subsequently, other two primers known as loop primers have been incorporated: loop primer forward [LPF] and loop primer backward [LPB] able to accelerate the amplification reaction (Nagamine, Hase et al. 2002) (Fig 1).

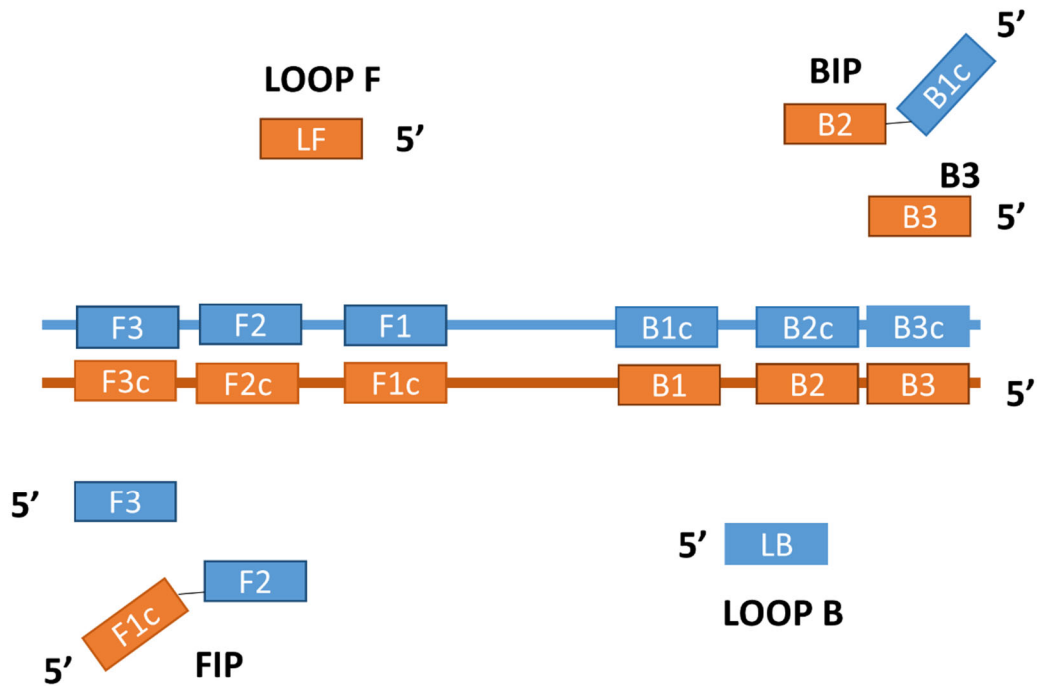

Fig 1. Schematic representation of designated DNA target sequences and primer design for LAMP. Six distinct sites on the target DNA are recognized in the LAMP technique: two outer primers (F3 and B3), two inner primers, a forward inner primer (FIP) and a backward inner primer (BIP). FIP and BIP have two distinct sequences (known as hybrid primers) being one of them for priming the first step (F2 or B2 at the end 3') and the other one for self-priming in later stages (F1C or B1c at the end 5'). LF and LB are known as loop primers and are able to accelerate the amplification reaction.

One of the great advantages of LAMP is its high performance (sensitivity and specificity) due to the large amount of genetic material (up to 10^{10} copies) generated from a few copies of DNA and the binding of the multiple primers (Notomi, Okayama et al. 2000). The fact that the amplification takes place at a constant temperature allows the reaction to be performed in a simple thermoblock or water bath, not being required the use of more sophisticated equipments such as thermocyclers. In addition, the Bst polymerase is more tolerant than other PCR polymerases to the presence of inhibitors contained in the biological samples which allows that the DNA template can be obtained by direct heat sample treatment not being required a previous step for the DNA extraction. The LAMP mechanism is divided in two stages: a cyclic phase and a non-cyclic phase (Fig 2A-D & 3).

The **non-cyclic phase** starts with the binding of the FIP primer by the interaction F2-F2c (primer-DNA targeted sequence) at the 5' end of the target DNA and the subsequent elongation. Next, the

first external F3 primer is joined to the sequence F3c which is located outside the junction of the FIP, displacing the previously formed one due to the chain shift activity of the Bst polymerase and releasing a very long strand with the first FIP at one end. Then, the complementary process takes place by joining the primer sequence B2 on the first BIP primer to the target DNA sequence B2c, subsequent elongation and interaction of the first B3 primer with the sequence B3c. When replicating again the DNA, a strand of small length is released that presents the FIP and BIP primers at each extreme which results in the generation of a loop structure.

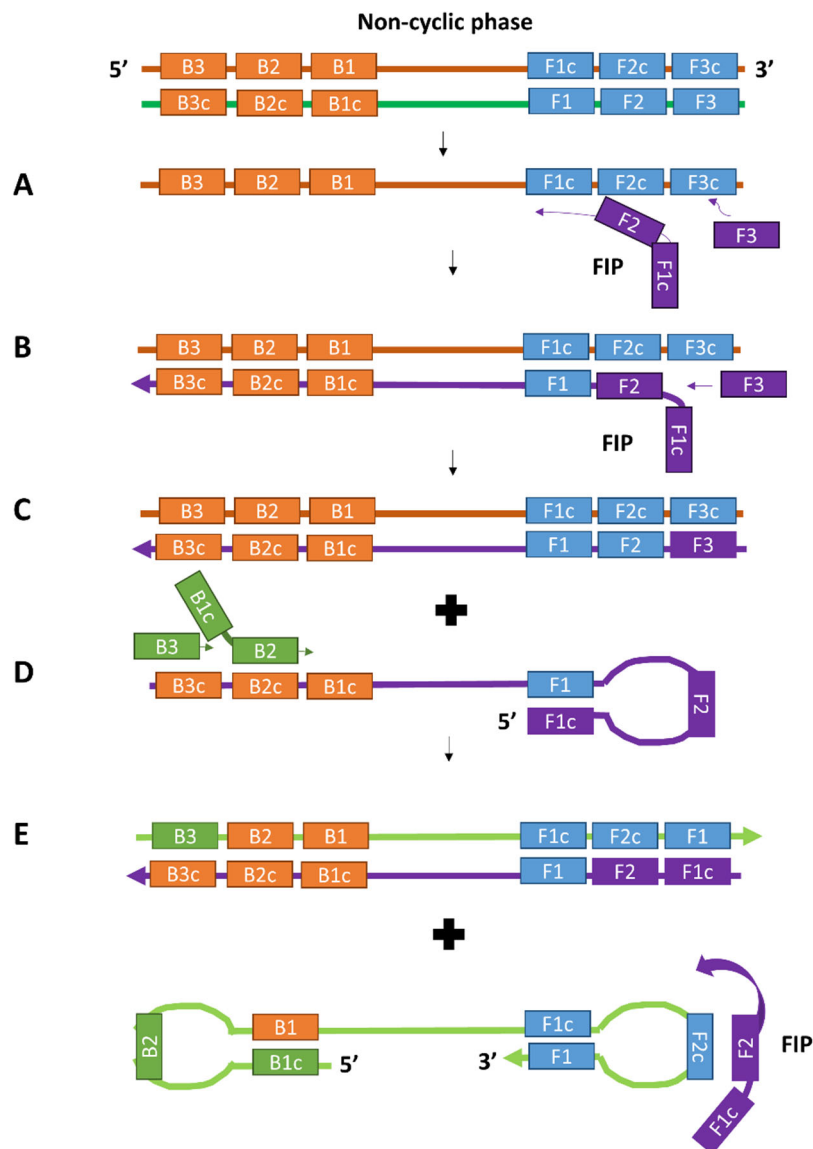

Fig. 2 First step of LAMP mechanism: the non-cyclic reaction and formation of dual looped DNA strand. Modified from (Bruce, Leterme et al. 2015). A) DNA synthesis initiated from FIP. B) F3 primer annealing and strand displacement DNA synthesis. C) DNA elongated from FIP

forms a loop structure at its 3' end. D) DNA elongation from BIP and B3 primer in the same manner as (A-C). E) Stem-loop DNA as starting material for LAMP cycling (Animation 2018).

The **cyclic phase** begins from the strand formed during the previous phase which presents a loop at each end (Fig 3). This phase has a rather complex mechanism in which only internal primers intervene. Using the DNA strand, the complementary strand is also formed with a loop at each end, and *viceversa*. During this process, a multitude of intermediate amplified DNA products of different sizes are formed to which the internal primers can also be joined and new amplifications can be started. When amplification is achieved, LAMP creates large amounts of DNA strands that contain multiple copies of the target DNA (Ushikubo 2004). During this reaction, magnesium pyrophosphate is generated as an insoluble white precipitate which becomes visible when the reaction is terminated. The increase of the magnesium pyrophosphate can be quantified by turbidity measurements (Mori, Nagamine et al. 2001).

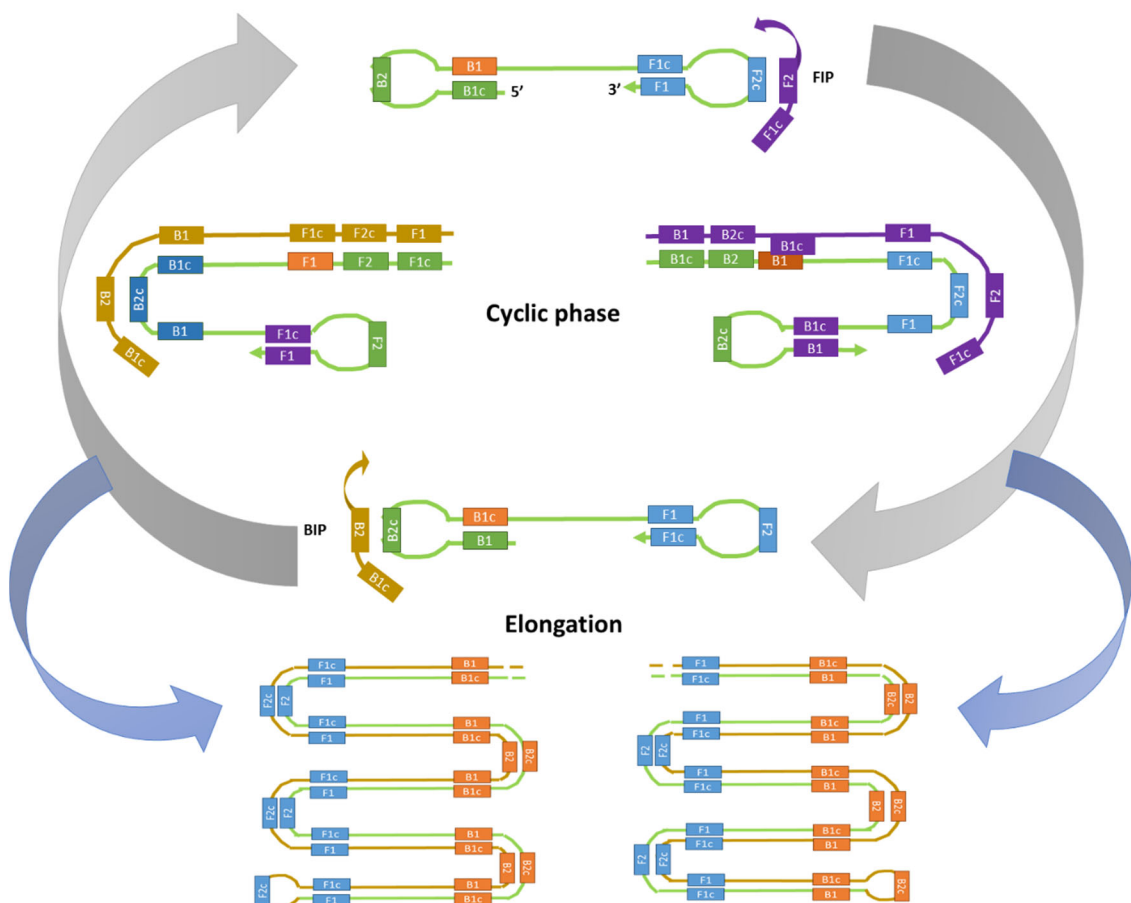

Fig. 3 Second and third step of LAMP: the cyclic amplification and elongation leading to strand displacement DNA synthesis. Modified from (Bruce, Leterme et al. 2015).

Later modifications of this technique focused in enabling visualisation of the reaction using the so-called non-intercalating agents (like calcein (Tomita, Mori et al. 2008) and hydroxynaphthol blue (HNB) (Goto, Honda et al. 2009), which induce a colour change by chemical reaction. These agents do not inhibit the amplification process *per se* and can be incorporated from the beginning of the reaction avoiding the manipulation of the amplified products and decreasing the risk of contamination. Also, the detection of the amplified products can be performed using other intercalating agents such as SYBR® Green I that originates a colour change from orange (negative) to green (positive) (Zhang, Lowe et al. 2014). The main problem associated with the used of the latter component is that at certain concentrations can inhibit the amplification process and thus, it must be added at the end of the reaction increasing the risk of cross-contamination. Apart from for the reagents above mentioned, there are other more expensive agents that can be utilised, however, their use in developing countries is refractive (Zhang, Lowe et al. 2014).

3. LAMP AS POCT(s)

Originally, the LAMP technique did not strictly comply with all the ASSURED requirements in order to be applied as POCTs. However, various strategies have been developed with the aim to solve problems related to the maintenance of the cold chain, the avoidance of a previous DNA extraction, the development of new devices that facilitate its practical application in the field and the improvement in sensitivity and specificity (fig 4).

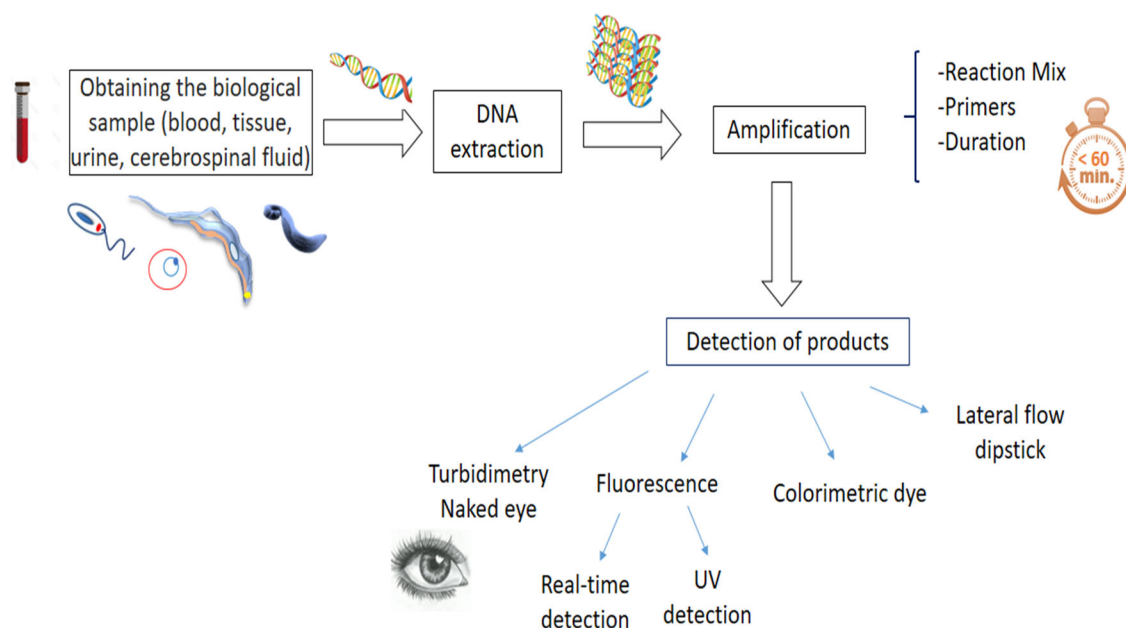

Fig. 4. Schematic workflow of a LAMP assay. In LAMP, denaturation of the double DNA helix is not required which makes simpler and shorter the process of the DNA extraction. However, the key factor for the success of the technique are the proper selection of the primers and the detection method as they will determine both the sensitivity and specificity of the assay.

3.1. DNA extraction

In the POCTs, there is a tendency to simplify and shorten all the steps, including the DNA extraction process. The classical extraction protocols of DNA such as phenol-chloroform, spin columns or magnetic beads, usually require some laboratory equipment and are time-consuming, so they have been replaced by other types of systems, the most frequently used, especially for blood samples such as rapid boiling methodology (Foley, Ranford-Cartwright et al. 1992), Chelex-100 resin (Wooden, Kyes et al. 1993), microwave irradiation method (Port, Nguetse et al. 2014) and more recently PURE DNA Extraction Kit, specially adapted for LAMP assay (FIND 2018).

3.2. Reaction phase

In order to avoid the need for cold transport and storage, the reaction mixture must be stabilized to avoid deterioration over time (Thekiso, Bazie et al. 2009). Several methods have been used to stabilize the components of the LAMP reaction mixture such as drying (Hayashida, Kajino et al. 2015) and lyophilisation (Carter, Akrami et al. 2017) incorporating trehalose as a cryoprotectant. Another strategy consists on making modifications in the polymerases employed in the amplification in order to improve its stability. For example the Bst 2.0 Warm Start polymerase is a homolog designed *in silico* of the native Bst polymerase (Bst polymerase Large Fragment) but with a higher yield and reversibly linked to an aptamer that inhibits the enzyme up to 45°C (Tanner, Zhang et al. 2012). This avoids that the amplification step occurs during the preparation of the reaction mixture at room temperature and the storage of the reactions without refrigeration for hours without altering the final result (Poole, Tanner et al. 2012).

3.3. Detection Systems

One of the advantages of LAMP lies in the possibility of visualizing the results with the naked eye or by simple techniques such as turbidimetry, since during the reaction, magnesium pyrophosphate is produced as a by-product in the form of an insoluble white precipitate which becomes visible, reducing the need for sophisticated equipment. The oldest studies basically used the visualization

of the precipitate of magnesium pyrophosphate (Poon, Wong et al. 2006, Han, Watanabe et al. 2007).

However, in order to increase the sensitivity, the visualization method has been modified, due to difficulties in the interpretation of the results and the visualization of amplified products. Some fluorescent, colorimetric or combined detection systems have been developed with the disadvantage of requiring expensive equipment for analysis (Fig. 5) (Parida, Sannarangaiah et al. 2008).

There are several reagents employed as detections systems (Table 2). **Calcein** is a chelating agent able to bind manganese ions present maintaining its fluorescence quenched. During amplification, the generated pyrophosphate ions will progressively depress the calcein molecules from manganese ions, resulting in an emission of green fluorescence when irradiated under natural, UV or blue light (Tomita, Mori et al. 2008). Other one is **SYBR Green I**, this molecule behaves as an intercalating agent that changes colour from orange to green upon interacting with DNA. It has the advantage that it can increase the sensitivity using UV light (Zhang, Lowe et al. 2014). Another reactive is **SYTO-9** con la advantage of having a lower background noise and a better distinction from baseline fluorescence. This will lead to a reduction in misclassification of cases and non-cases by the users in the field (Patel, Oberstaller et al. 2013).

Table 2. Most commonly employed detection systems in LAMP.

Reagents	Detection type	Color change	Cost	Remarks
Magnesium pyrophosphate	Naked-eye Turbidimetry	-	+	Formed during the amplification process
Calcein	Fluorescence	Orange (-) Green (+)	++	Pre-added in the reaction mixture
SYBR-green I	Fluorescence/Colorimetric	Orange (-) Green (+)	+++	Added at the end of the process which may lead to cross-contaminations
Hydroxynaphtol Blue (HNB)	Colorimetric	Violet (-) skyblue (+)	++	Pre-added in the reaction mixture
Malachite Green (MG)	Colorimetric	Colourless (-) green/blue (+)	+	Pre-added in the reaction mixture

The chemical agents used in colorimetric assays are not intercalating agents but produce a change of colour based on a chemical reaction. These agents have the advantage of not inhibiting the amplification process and can be added from the beginning of the reaction, thus avoiding the subsequent manipulation of the amplified products and decreasing the risk of contamination, such

as HNB (Goto, Honda et al. 2009) or MG dyes (Lucchi, Ljolje et al. 2016).

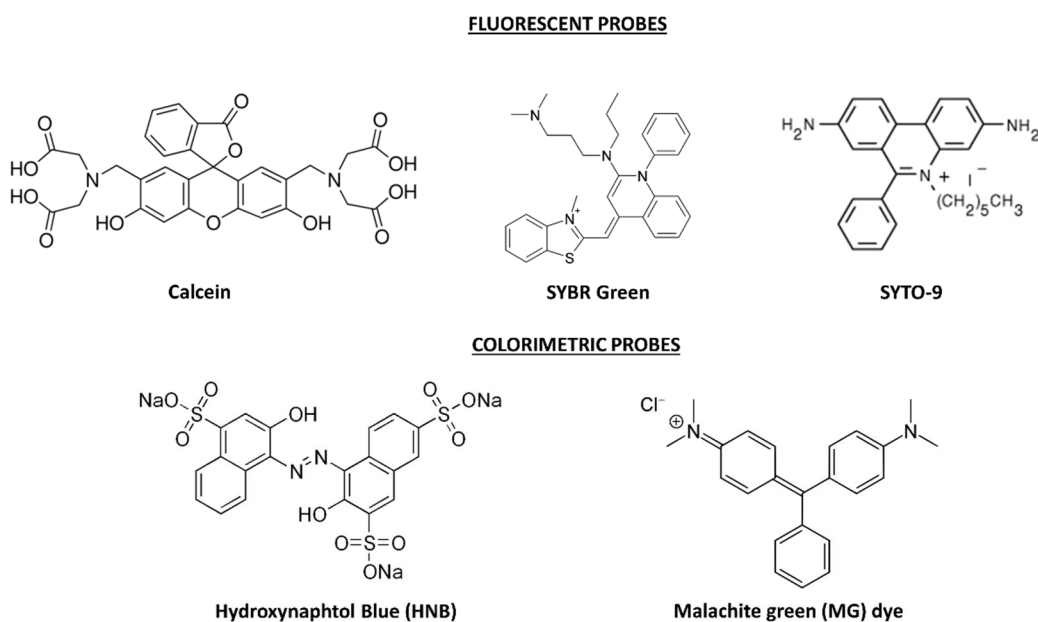

Figure 5. Chemical structure of most commonly used fluorescent and colorimetric probes in LAMP assay.

4. LAMP IN MALARIA DIAGNOSIS

Malaria is caused by parasites of genus *Plasmodium* (*P. falciparum*, *P. vivax*, *P. ovale*, *P. malariae* and *P. knowlesi*) that are transmitted through the bites of infected female *Anopheles* mosquitoes. In 2016, there were estimated 216 million cases of malaria in 91 countries along with 445,000 deaths (WHO 2018).

Malaria infection produces fever and other non-specific symptoms such as rigors, headache, nausea and muscle aches. The most severe form of the disease is produced by *P. falciparum* and if the infection is not treated progresses to severe or complicated malaria, (severe anaemia, cerebral malaria, and respiratory distress) which may lead to death (Cowman, Healer et al. 2016).

A rapid and correct diagnosis is essential, as well as an adequate treatment. Traditionally, the gold standard technique recommended to diagnose patients was the optical microscopy consisting on the observation of the parasite in blood by means of a smear or a thick drop and later staining the parasitic forms performed by highly qualified personnel. In the endemic areas, the WHO has indicated as priority the development of adequate diagnostic techniques to avoid the excessive prescription of antimalarial drugs, since in many cases clinical diagnosis of the disease was only made, without the appropriate and accurate laboratory diagnosis confirming the disease.

Immunochromatographic tests are rapid and accurate and very useful in the diagnosis of malaria. They are based on the capture of a parasite antigen from blood using monoclonal antibodies prepared against a malaria antigen target and conjugated to either a liposome containing selenium dye or gold particles in a mobile phase. Malaria antigens currently targeted are HRP-2 and pLDH (Moody 2002). Sensitivity will always depend on the concentration of the target antigen (protein) present in blood and will therefore vary with parasite density and may be reduced in areas where parasite densities are frequently < 200 parasites/ μ l (WHO 2018).

There are numerous areas of low intensity of malaria transmission, where there are a large proportion of asymptomatic cases that are not detected microscopically. These asymptomatic individuals are a serious public health problem as they act as reservoirs for malaria transmission, making the elimination of the disease difficult. In non-endemic countries, the lack of experience of clinicians and laboratory technicians leads to delays and diagnostic errors, especially when the parasitaemia is very low and therefore can have fatal consequences. For this reason, in recent years, studies have been carried out in order to develop diagnostic tools for malaria with a greater sensitivity, specificity and cost-efficiently (Table 3).

The first time LAMP was used in the diagnosis of malaria, was based on the detection of highly conserved 18S ribosomal RNA gene of *P. falciparum* without cross reaction with other human *Plasmodium* spp. Samples from Thailand, previously diagnosed by optical microscopy, were selected. The sensitivity and specificity of the LAMP technique was 95% and 99% respectively in relation to a conventional PCR, but with the additional advantage that the LAMP technique did not require prior DNA extraction, and visualization of the results it was performed through a real-time turbidimeter (Poon, Wong et al. 2006).

Consecutively, Han et al (2007) developed an assay that allowed for differentiate between *P.falciparum*, *P. vivax*, *P. malariae* and *P. ovale*. The *Plasmodium* genus- and species-specific LAMP primer sets were designed on the basis of specific nucleotide sequences of the 18S rRNA genes of the 4 species. Positive samples were also analysed by optical microscopy. In this case, a pre-extraction process of the DNA with Chelex-100 was performed and the visualisation was carried out by turbidimetry. Apart from the high sensitivity and specificity similar to nested-PCR, the shorter processing time (half an hour) and the lower limit of detection (even when parasitaemia was very small (0,01% for *P. falciparum*) were additional advantages over the latter technique (Han, Watanabe et al. 2007).

Most of the studies carried out so far have continued using as primers those that use the 18S rRNA as a target. They have been applied in studies carried out in different parts of the world, mainly to identify *P. falciparum* and *P. vivax*, although including modifications in the process of DNA extraction, use of thermoblock/bath, or the way of visualising the results. In any case, the aim was to simplify the process in order to apply the technique in remote areas with few infrastructures. Most of the countries where these studies have been conducted are endemic to *P. falciparum* and/or *P. vivax* malaria such as Thailand (Poschl, Waneesorn et al. 2010, Sattabongkot, Tsuboi et al. 2014), remote areas of central China with difficult access (Lu, Gao et al. 2012), in rural areas of Uganda (Hopkins, González et al. 2013), Bangladesh (Mohon, Elahi et al. 2014), Iran (Ghayour Najafabadi, Oormazdi et al. 2014), India (Patel, Lucchi et al. 2014, Singh, Singh et al. 2017), Zanzibar (Morris, Khamis et al. 2015) and Ethiopia (Cuadros, Perez-Tanoira et al. 2015).

In countries where the disease is not endemic and there are no expert technicians available for its diagnosis, the 18S rRNA gene-based LAMP for diagnosis of imported malaria has also been used with a superior sensitivity to optical microscopy in Switzerland (Marti, Stalder et al. 2015) and Canada (Rypien, Chow et al. 2017). However, the sensibility of the 18S rRNA gene-based LAMP varies depending on the specie. For example, it can detect up to 50 parasite/μl of *P. falciparum*, *P. vivax* and *P. ovale*, but up to 500 parasites/μl of *P. malariae*. For this reason, different primers towards different targets have been developed to improve the sensitivity of the LAMP technique.

Polley et al., 2010 developed an extensive work to select the most suitable primers. Eighteen genomic targets comprising both multiple- and single-copy loci were examined using First Explorer to find either species-specific or pan-genus first set. Mitochondrial gene-based (mtDNA) gave a positive result when tested with samples with very low parasite densities (5 parasites/μl) in much shorter time (< 30 min) compared to nested PCR protocols (Polley, Mori et al. 2010). The mitochondrial DNA (mtDNA) has been also chosen by other authors as the target region, because it is a plasmid-like multicopy non-nuclear DNA that it is easy to extract using the boiling method (Tao, Zhou et al. 2011). LAMP assays based on mtDNA has been employed in a wide range of countries for different purposes. In Colombia, this test has been used to differentiate *P. falciparum* from *P. vivax* (Vallejo, Martinez et al. 2015). In Ethiopia, mtDNA based-LAMP has been applied in the early detection of malaria in pregnant women leading to high sensibility (Tegegne, Getie et al. 2017). In a larger study in Papua New Guinea, Malaysia, Ghana and Gambia, hydroxynaphthol blue was used as a colorimetric indicator in order to optimise the detection of malaria parasites (Britton, Cheng et al. 2015). Overall, using this technique, all the five human malaria species can be adequately differentiated with minimal instrumentation (Sattabongkot, Tsuboi et al. 2014, Lau,

Lai et al. 2016). Currently, the first kit in the market based on mtDNA is able to detect even up to 1 parasite/ μ l of blood in less than 40 min (Gonzalze, Polley et al. 2011). This kit (Loopamp™ malaria Pan/Pf detection kits commercialised by Eiken Chemicals, Tokyo, Japan) employs primers from mtDNA consisting of plastic reaction tubes containing thermostable vacuum-dried reagents used to amplify Pan-*Plasmodium/P. falciparum* DNA which will be further described in more detail below.

Other authors have selected mitochondrial cytochrome C oxidase subunit 1 gene which has also shown high sensibility and specificity in *P.falciparum* and *P. vivax* infections (Modak, Barber et al. 2016). Other targets also used in LAMP assays are characterised by being conserved genes with several copies that are not in the genome of the host. The apicoplast is a plastid organelle, homologous to the chloroplasts in plants and found in some apicomplexan parasites like *Plasmodium* or *Toxoplasma*. It is semi-autonomous with its own genome and expression machinery and its genome copy number has been estimated to be approximately 15 for *P. falciparum* (Waller and McFadden 2005). The fact that presents a high number of copies makes the apicoplast a good candidate with high specificity and sensitivity able to detect low-density infections (2 parasites / μ L) (Oriero, van Geertruyden et al. 2015, Oriero, Okebe et al. 2015).

Although several trials have shown that *P. falciparum* can be differentiated from the rest of the genus species, due to the resurgence of *P. vivax* in various parts of the world, many authors have tried to design a LAMP assay able to detect *P. vivax* with the following characteristics: high sensitivity, specificity, fast and cost-efficient. In addition, it is important that the technique allows the detection of the parasite at the beginning of the infection or in case of relapses, and also when there are low parasitaemia since it has been shown that *P. vivax* can be easily transmitted in transfusions.

At this respect, Patel et al. has used Pvr64 as target which is a highly conserved repeat family. They are six copies in the *P. vivax* genome. Five copies are on small contigs that are not assembled into chromosome scaffolds. As the Pvr64 family has a high degree of identity among the different species of *Plasmodium*, authors designed the primers (set r64) taking into account these similarities to avoid cross reactions. In order to validate the specificity of the first set r64, *P. vivax* strains from different geographic regions (Miami, El Salvador, Honduras, Mauritania, Indonesia, India, South Vietnam, North Korea, Thailand, New Guinea, Panama, Chesson, and Pakchong) were tested (Patel et al., 2013) The designed primers were able to detected *P. vivax* in the clinical samples with 94.59% sensitivity and 100% specificity compared to the gold standard nested-PCR method (Patel, Oberstaller et al. 2013).

More recently, Britton et al. have designed an assay targeting the conserved *cox1* gene which has demonstrated to possess excellent analytic sensitivity, being able to detect 1.4 parasites/ μ L (Britton, Cheng et al. 2016). The reason is due to the 11 copies/cell of *cox 1* that are found in *P. vivax*, which greatly improves the sensitivity in relation to previous studies based on the 18S rRNA gene and even in others studies based on other chromosomes (r64 first set with a sensitivity around 125 parasites/ μ L) (Patel, Oberstaller et al. 2013).

Another target gene tested for the diagnostic of *P. vivax* is α -tubulin, which has a detection limit of 100 copies/per reaction with a duration of 50 min. Validation of the α -tubulin LAMP assay showed the highest sensitivity when nested PCR was used as the gold standard (Dinzouna-Boutamba, Yang et al. 2014). LAMP assays have also targeted the identification of *P. knowlesi*, which is in many cases misdiagnosed by microscopy. Under microscopy, the early trophozoites are resembled morphologically those of *P. falciparum*, while the late and mature trophozoites, schizonts and gametocytes were generally indistinguishable from those of *P. malariae* making extremely difficult to identify *P. knowlesi* infections using only microscopy (Lee, Cox-Singh et al. 2009). Other LAMP assays were developed to exclusively identify *P. knowlesi* using other targets such as the apical membrane antigen-1 (AMA-1) gene found in all *Plasmodium* parasites during the late schizont stage. This protein plays a crucial role in the invasion of the host cell. LAMP has shown to be highly sensitive with the detection limit as low as ten copies for AMA-1 plasmid compared to nested PCR (100 copies) (Lau, Fong et al. 2011). However, Britton et al. showed that specificity was very low (53-55%) compared to microscopy and multiplex PCR when validating the gene COX1 as a target for *P. vivax*, due to the cross-reactivity between *P. vivax* and *P. knowlesi* COX1 (Britton, Cheng et al. 2016).

In order to increase the sensibility of the technique, several researchers have used fluorescent probes such as SYBR Green I (Patel, Oberstaller et al. 2013, Oriero, van Geertruyden et al. 2015, Singh, Singh et al. 2017).

The fact of adding SYBR Green at the end of the reaction implies the need to open the tubes and thus, the reaction mixture can be easily contaminated leading to erroneous results. Therefore, alternative systems have been sought to include the fluorochrome at the beginning of the reaction. In this sense, a range of incorporation systems of the fluorochrome has been developed. For example, microcrystalline wax-dye capsule containing the highly sensitive DNA fluorescence dye SYBR Green I have been prepared being incorporated at the beginning of the reaction leading to the release of the DNA dye to the reaction mixture only when the temperature is raised to the

melting point following amplification. Soon after cooling down, the solidified wax seals the reaction mix at the bottom of the tube, thereafter reducing the risk of aerosol contamination. This system allows for sensitivity and specificity of 98.3% and 100% respectively and quick visualised LAMP method, which is feasible for malaria diagnosis in resource-limited field settings (Tao, Zhou et al. 2011). Nevertheless, Paris et al. showed that the UV fluorescence method produced a high rate of false positives and suggested that this method should be avoided as a LAMP read-out (Paris, Imwong et al. 2007).

Several authors have used the pre-addition of hydroxynaphthol blue (HNB) in the malaria LAMP reaction to improve the sensitivity of the technique making feasible to detect at least 5 parasites/ μ L in infected blood (Mohon, Elahi et al. 2014, Port, Nguetse et al. 2014, Britton, Cheng et al. 2015).

Malachite green (MG)-LAMP assay has several advantages over other detection systems being very useful in epidemiology studies for malaria. The MG signal is highly sensitive and non-subjective, facilitating the visual discrimination of results without any specialised and costly equipment such as turbidimeters or fluorescence readers. The colour change is visible for up 4 weeks and the reagent can be added in the reaction mixture prior to amplification avoiding cross contamination and does not require a cold chain for storage (Lucchi, Ljolje et al. 2016).

Yongkiettrakul et al., have developed a malaria LAMP-LFD system including the use of species-specific biotinylated primers to amplify LAMP amplicons, which were hybridised to specific FITC-labelled DNA probes and visualised on a chromatographic lateral flow dipstick. The duration of the assay was 1.5 h with similar sensitivity to conventional PCR when performed on plasmid DNA from malaria DHFR-TS genes, but 10 times higher when carried out on genomic DNA from *P. falciparum* and *P. vivax* parasites (Yongkiettrakul, Jaroenram et al. 2014).

Table 3. Summary of several LAMP modifications applied in the diagnosis of malaria.

NAME	MODIFICATIONS	ADVANTAGES	REFERENCE
RealAmp LAMP-Tube scanner	Contains an analyser	During LAMP, specific amplification products can be formed but also some non-specific products. To avoid this phenomenon, a combined the LAMP method with a melting curve analysis using an analyser has been employed	(Yamamura, Makimura et al. 2009)
ESE-Quant Tube Scanner (Commercial manufacturer by ESE GmbH, Stockach, Germany)	Simple portable device (tube scanner) in which both the amplification platform (heating block) and fluorescent detection unit for end point use are incorporated	The tube scanner is extremely sensitive, robust, and cost-effective and is easily portable	(Lucchi, Demas et al. 2010)
Chromatographic lateral flow dipstick (LFD, Milenia® GenLine HybriDetect)	LAMP-amplicons are hybridised to specific FITC-labeled DNA probes and visualised on a chromatographic lateral flow dipstick (LFD)	Greater sensitivity (up to 0.001 ng of genomic DNA)	(Yongkiettrakul, Jaroenram et al. 2014)
NINA-LAMP	Non-instrumented nucleic acid amplification (NINA) coupled with LAMP system	Electricity-free nucleic acid amplification	(Sema, Alemu et al. 2015)
AnyMDx system	Disposable microfluidic disc, which incorporates integrated sample preparation steps of DNA extraction, purification, elution and amplification	Low cost, rapid and accurate amplification	(Choi, Song et al. 2016)
CZC-LAMP	Direct blood dry LAMP	DNA extraction is not necessary to detect low-density, even falciparum/non-falciparum mixed infection with a high degree of accuracy in blood samples	(Hayashida, Kajino et al. 2017)
LAMP-MinION™ nanopore sequencer	The MinION™ nanopore sequencer is a pocket-sized and USB-connected portable real-time sequencer. Amplicon sequencing of LAMP products using MinION™ allows to identify each <i>Plasmodium</i> species	Rapid, simple, and highly sensitive system. Amplicon sequencing of LAMP products using MinION™ allows to identify each <i>Plasmodium</i> species. Identification of species and genotyping polymorphisms and resistant species	(Imai, Tarumoto et al. 2017)
Multiplex microfluidic LAMP (mμLAMP) array system	All analytical steps are integrated onto a chip including sample collection, nucleic acid preparation and molecular detection	Visible with naked-eye, sensitive, specific and high-throughput diagnostic LAMP	(Mao, Ge et al. 2018)
3D printed microfluidic reactor array	Fully 3D printed microfluidic reactor array that is capable of carrying out extraction, concentration and isothermal amplification of nucleic acids	Miniaturised, inexpensive and multifunctional diagnostic device that can detect nucleic acids from complex biological samples	(Kadimisetty, Song et al. 2018)

5. COMMERCIALY AVAILABLE LAMP KITS FOR MALARIA

Currently there are two commercially available certified LAMP systems malaria from Eiken Chemical Co. and Meridina Bioscience Inc as described below.

5.1. Loopamp MALARIA kit (by Eiken Chemical Co.)

The Loopamp™ workflow allows for an easy DNA extraction and preparation of reaction mixtures in a just few steps without any additional equipment. It has been listed in the WHO Policy brief on malaria diagnostic in low-transmission settings. Reagent storage and shipment can take place at room temperature (as contains lyophilised reagents) and the test performance make possible that the molecular pathogen identification can be performed in rural areas. Differentiation between *Plasmodium* pan-species and *Plasmodium falciparum* is possible using this kit. It has high specificity (97 - 100%) and sensitivity (96 - 100%) with a detection limit of 1 parasite/μl and a duration of the process less than one hour. The interpretation of the results is easy and can be performed either visually or by means of a turbidimeter.

5.2. Illumigene Malaria LAMP (by Meridian Bioscience Inc., Cincinnati, OH).

This kit consists of pre-dispensed, ambient temperature stable LAMP reagents designed to detect malaria parasites at the genus level. The LAMP assay is performed using the illumipro-10™ Incubator Reader. The change in turbidity associated with LAMP assays, due to the magnesium-pyrophosphate build-up as a product, is measured by the illumipro-10™ reader and a qualitative result is determined. The kit uses a gravity filtration system to extract DNA instead centrifuge methods. It has a high sensitivity of 100% and a good specificity of 89.3%, the process duration is less than 50 minutes and the limit of detection ranged between 2.0 parasites/μl to 0.3 parasites/μl (Lucchi et al., 2016).

6. LAMP ASSAYS FOR DIAGNOSIS OF LEISHMANIASIS

Leishmaniasis is produced by more than 20 species of the parasitic protozoan *Leishmania* and is transmitted by infected female sandflies. According to the WHO, leishmaniasis is endemic in more than 98 countries and an estimated 350 million people are at risk. Clinical manifestations include from tegumentary leishmaniasis (TL) to the deadly visceral leishmaniasis (VL) (WHO 2018). The clinical evaluation of the signs and symptoms can guide the diagnosis, thus patients with VL will

frequently present fever, fatigue, loss of appetite and weight, and in more advanced stages of the disease, anaemia, enlargement of ganglia, splenomegaly and hepatomegaly. In addition, in the case of *L. donovani*, cutaneous lesions known as Post-kala-azar dermla leishmaniasis (PKDL) can appear after apparent healing, which has been mainly reported in India and Sudan (Zijlstra 2016).

The term of tegumentary leishmaniasis (TL) refers to all forms of leishmaniasis that have skin manifestations. Depending on the *Leishmania spp.* and the immune system of the host, the clinical sign and symptoms can vary leading to Localized Cutaneous Leishmaniasis (LCL), Anergic Difusse Cutaneous Leishmaniasis (ADCL) or Mucocutaneous or Mucosal Leishmaniasis (ML) (WHO 2018). LCL is the most frequent manifestation characterised by one or multiple ulcerated skin lesions. ADCL is characterised by a diffuse infiltration in the skin with nodules and papules that rarely form ulcers. In contrast, ML is characterised by a destructive mucosal inflammation. This diversity along with atypical lesions such as papules, verrucose vegetative lesions and skin infiltrations is related to the wide genetic variety in *Leishmania spp.* (Silveira, Lainson et al. 2004). The diversity in terms of clinical forms leads to inappropriate diagnose and hence, a delay in the instauration of the correct treatment and complications (Merino-Espinosa, Corpas-Lopez et al. 2018).

Apart from the clinical manifestations, the diagnosis must be confirmed by other techniques, being the direct parasitological diagnosis as the gold standard due to its high specificity which is based on the demonstration of the presence of amastigote forms of the parasite by microscopic examination and staining of the tissues or the culture of the parasites from the samples of the patient. The main limitation is to obtain the samples, since it is necessary to use invasive techniques, like biopsies or scrapings from the lesion in the case of cutaneous forms and bone marrow or splenic aspirates in the VL (de Vries, Reedijk et al. 2015).

In addition, the correct identification of the amastigotes in the stained imprints will depend on the quality of the reagents used as well as on the experience of the laboratory personnel. Therefore, it is common to culture the sample in a suitable medium such as NNN (Novy, Nicolle and McNeal). However, the technique is tedious, time-consuming and expensive (Srividya, Kulshrestha et al. 2012).

Immunological techniques, such as direct agglutination (DAT), indirect immunofluorescence (IFAT), ELISA or western-blot, are an alternative to direct diagnosis, although instrumentation is still required. The main disadvantage of immunological techniques is that they can cross-react with other parasitic diseases and autoimmune diseases, and also, antibody levels can remain elevated for a long time, making difficult to diagnose relapses.

For this reason, in recent years, rapid techniques based on the detection of antigens, such as latex agglutination (Sundar et al., 2006) and immunochromatographic assays based on the search for k39 antigen, have been developed with great success for VL (Maia et al., 2012).

Alternatively, several PCR-based techniques have also been developed for the diagnosis of leishmaniasis (such as multiplex, nested, restriction fragment length polymorphism or quantitative real-time) based on the detection of various genes or genomic regions that offer different sensitivities and specificities. The main disadvantage of the use of this technique is that they require qualified personnel, expensive infrastructure and the time of experiment which limits its application as POCTs (Singh and Sundar 2015).

Regarding LAMP assays, despite its numerous advantages compared to other DNA-based techniques, there are a limited number of studies regarding its use in the diagnosis of leishmaniasis. So far most studies aim to avoid if possible the use of invasive methods to obtain the sample. Even though, different primers have been developed in order to identify the genus *Leishmania*, no discrimination between different species has been achieved (Takagi, Itoh et al. 2009).

Kinetoplastid parasites have a structure called kinetoplast that is constituted by mitochondrial DNA (kDNA) arranged in maxicircles and minicircles being of great interest in the design of specific primers. In several studies, primers based on the kDNA have been designed, specially oriented to the differential diagnosis of *Leishmania* spp. Takagi et al., 2009, applied a LAMP technique to detect *Leishmania donovani* DNA which was 10-fold more sensitive (up to 1 fg) than conventional PCR and did not interfere with other *Leishmania* species (*L. infantum*, *L. major*, *L. mexicana*, *L. tropica*, *L. braziliensis*) (Takagi, Itoh et al. 2009).

The same primers were successfully applied using directly human blood. LAMP assay showed high sensitivity (being positive in 68 out of 75 of the confirmed VL infected patients) and high specificity (all controls were negative) being a better technique than PCR (Khan, Bhaskar et al. 2012).

In a larger study with 200 samples from patients with VL infected *L. donovani* and post-kala-azar dermal leishmaniasis (PKDL), using the same primers as above mentioned. LAMP was positive in 53 out of 55 blood samples (sensitivity 96.4%), 15 out of 15 bone marrow aspirate samples (sensitivity, 100%) and 60 out of 62 PKDL tissue biopsy samples (sensitivity, 96.8%). A LAMP modification incorporating the use of SYBR Green I for clear-cut naked eye detection was employed (Verma, Avishek et al. 2013).

In another study conducted in Iran, blood samples from 47 patients with clinical manifestations (hepatosplenomegaly, anaemia and fever) characteristic of VL and confirmed by an immunological diagnosis by the direct agglutination test (DAT) were analysed using LAMP. As control, 40 negative samples were used by DAT from non-endemic areas with no clinical signs or symptoms. A set of six targeting *Leishmania infantum* kDNA minicircle genes was designed for LAMP. The final detection was performed by observable turbidity with the naked eye. Even though, confirmation of the results was obtained by SYBR Green I and the colour change (green for the positive samples and orange for the negative samples). A more exhaustive confirmation was carried out by transferring the LAMP products for electrophoresis in agarose with ethidium bromide and visualizing under UV light. The detection limit was 1 parasite per 1 ml of blood, with a sensitivity of 93.6% and a specificity of 100%, similar to those obtained with nested PCR used as a control. In addition, it was a specific test for detection of *L. infantum*, without interference of the rest of the species within the genus *Leishmania* (Ghasemian, Gharavi et al. 2014).

One of the disadvantages of using the minicircles for primer design is that are highly variable, so they are not very suitable since this technique requires at least six conserved regions. The small subunit (SSU) 18S rRNA gene is one of the most used genes in phylogenetic studies, since they present a large number of copies. For this reason, several primers based on these genes have been developed in order to differentiate the different species. Adams et al have used a reverse transcriptase-loop-mediated isothermal amplification (RT-LAMP) assay in patients with VL from Sudan and with CL from Suriname to identify the *Leishmania* species responsible for the infection. The sensitivity of the RT-LAMP in the blood of the patients with VL was 83% in comparison with the analysis by microscopy of bone marrow and lymph node aspirates, whereas better results were obtained with CL, where the sensitivity was 98% (Adams, Schoone et al. 2010).

Although the sensitivity of LAMP using 18S region is good, at least between 10 and 100 parasites/ml are needed for detection. Additionally, the main drawback remains the false positives due to interferences with both *Trypanosoma cruzi* and *T. brucei*, due to the similarity of the 18S region among the kinetoplastids. Karani et al., 2014 developed a Pan-*Leishmania* LAMP assay using a sequence of *L. major* rRNA-encoding gene on chromosome 27 and designing two sets of primers to detect and differentiate *L. donovani*, *L. major*, *L. infantum*, *L. braziliensis*, *L. guyanensis*, *L. tropica*, *L. mexicana*, *L. amazonensis*, *L. chagasi*, *L. siamensis*, *L. naiffi*, *L. lainsoni* and *L. panamensis*. To develop the Pan-*Leishmania* LAMP assay, cultures of promastigotes of different *Leishmania* species were used. The so-called set 1 of primers led to better results in the detection

of the genus *Leishmania* with a limit of detection ranging from 30 pg to 36 fg of parasite DNA. In addition, no false positives were detected when analyzing other trypanosomatids such as *T. brucei* or *T. evansi*, or with other protozoa such as *Cryptosporidium parvum*, *Giardia intestinalis* or *Entamoeba histolytica*. However, this technique does not allow to differentiate between *Leishmania* species (Karani, Sotiriadou et al. 2014).

Other authors have also designed a pan-*Leishmania* assay, using as target the 18S ribosomal RNA gene, preparing a consensus sequence from nine different *Leishmania* species. The study was carried out on both culture promastigotes and samples (blood, saliva or skin) from patients in Thailand. To improve the level of detection and facilitate the interpretation of results, malachite green was included, which is easily applicable in low-resource areas since it is cheap and can be stored at room temperature as previously discussed. This technique allowed to detect different species of *Leishmania*, such as *L. martiniquensis* and *L. siamensis* which are highly prevalent in this region. In addition, it was possible to detect *Leishmania* DNA both in the blood and bone marrow of patients with VL, and also in the skin and saliva in CL patients, respectively. Therefore, this assay could be applied as a noninvasive technique using saliva or blood, with levels of detection similar to those reported by Karani et al. (Sriworarat, Phumee et al. 2015).

Overall, the LAMP technique allows to simplify and speed up the diagnostic process, however, the main problem is related to the DNA extraction process and in its conservation, especially in those environments where adequate infrastructures are not available to allow the correct preparation of the clinical sample and its storage requires refrigerated conditions. For this reason, several authors have combined the LAMP technique with FTA cards (Flinders Technology Associates) that protect the nucleic acids from oxidation, nucleases and UV damage at room temperature for long storage periods for the diagnosis of leishmaniasis. In this sense, Nzelu et al., 2016 have developed a one-step, single-tube, highly sensitive LAMP assay for rapid detection of *Leishmania* DNA from tissue spotted on an FTA card, which has incorporated malachite green for the final visualisation step. The validation of this system was carried out on tissue samples obtained by aspirating or scraping the lesions of CL patients from Peru. The developed system was fast (30 min), sensitive (detection levels as low as 0.01 parasites/ μ l) and specific (without cross-reactivity with the genomic DNA of *Trypanosoma cruzi*, *Trypanosoma brucei gambiense*, human and dog) (Nzelu, Caceres et al. 2016).

Another of the genes traditionally used in the molecular identification of *Leishmania* is the ribosomal ITS1, since it is a highly conserved gen. A LAMP assay has recently been optimized including two primers designed based on shared regions of the ITS1 gene and a third primer from a newly

identified region in the *Leishmania donovani* genome. The three systems allow to detect concentrations of *L. donovani* DNA (> 100fg), being more sensitive than the conventional ITS1-PCR (el Tai, Osman et al. 2000). To avoid contamination and false positives, the green nucleic acid stain SYTO16 was included in the initial reaction mixture at low concentrations making the test inexpensive, portable for real time monitoring and substantially more sensitive (> 100 fg of *L. donovani* DNA) than conventional ITS1-PCR or kDNA-PCR (Abbasi, Kirstein et al. 2016).

Recently, Eiken Chemical Co. (Japan), in collaboration with FIND and other partners, has developed the Loopamp *Leishmania* Detection Kit for commercialization (Eiken 2018). Target genes, 18S rDNA and kDNA, were chosen based on multiple strands and conservation across multiple strains and species of *Leishmania* across geographic areas, with the aim of being able to diagnose both VL and CL. Bst DNA polymerase is used for amplification, and the dry reagents include a calibration to allow for the visual detection of the amplified products without opening the reaction tubes (Adams, Schoone et al. 2018).

The selection of the target genes was performed using a bibliographic engine search and the analysis of the sequence alignment. Prototype primer sets were based on three target genes: i) the 18S rDNA gene, ii) the histone H3 gene for pan-*Leishmania* assays and iii) kDNA for a VL-specific assay. The detection limit (LOD) was evaluated using a real-time LAMP turbidimeter. The 18S rDNA gene had a LOD ranging from 0.01 to 0.001 parasite / μ l. The histone LAMP primers had a LOD similar to 18S rDNA but could not amplify all *L. guyanensis* and *L. braziliensis*. kDNA exhibited a LOD of 0.0001 parasite / μ l on *L. donovani* and *L. infantum* but there was no amplification with CL-causing *Leishmania* species.

The primers designed on 18S rDNA and kDNA genes were selected and combined to optimize the identification of VL using the dried-up LAMP assay developed by Eiken Chemical Co (Eiken 2018). The optimization of the assay was performed using samples of suspected CL patients from southwest Colombia (obtaining a sensitivity of 95% and a specificity of 86%). In the case of VL, 50 blood samples from Ethiopian patients were used, and the technique showed a sensitivity of 92.3% and a specificity of 100% on whole blood (Adams, Schoone et al. 2018).

Subsequently, several studies have evaluated the use of this kit using samples from different origins and on different species of *Leishmania*. Mukhtar et al., 2018 analysed blood samples from patients with VL in Sudan using two immunological techniques, the rK28 RDT and DAT. The rK28 RDT presented higher sensitivity and specificity (98.81% and 100 % respectively) than DAT. The LAMP kit had high specificity regardless of the type of DNA extraction method used or sample

analysed, (whole blood or buffy coat), avoiding the need for invasive lymph node aspiration (Mukhtar, Ali et al. 2018). Ibarra-Meneses et al., 2018, demonstrated that by combining this kit with a portable and robust real-time fluorimetry, a versatile assay able to diagnose VL in situations in which the serological diagnosis is useless such as in VL relapses and test-of-cure, or VL / HIV co-infection and even in canine leishmaniasis was possible (Ibarra-Meneses, Cruz et al. 2018).

7. LAMP IN DIAGNOSIS OF AMERICAN TRYPANOSOMIASIS (*T. CRUZI*)

American trypanosomiasis or Chagas disease is a parasitic infection caused by the protozoan *Trypanosoma cruzi*. It is a zoonosis transmitted by hematophagous insects of the family *Reduviidae*. There are alternative routes of transmission such as transfusion, mother-to-child, transplants of solid organs, consumption of food contaminated with the faeces of the insect vector, non-cooked meat of infected mammals or laboratory accidents. The exact number of infected people is unknown, although it is estimated that approximately 7-8 million people are infected worldwide (WHO 2018).

The diagnosis of Chagas disease varies according to the stage of the disease. In the acute phase, there are numerous peripheral blood parasites and it is possible to detect them by direct peripheral blood fresh microscopy due to their rapid movements between blood cells. Smears of peripheral blood and thick blood, properly stained, allow the observation of the morphological characteristics of the parasite. When the level of parasitaemia is low, however, it is necessary to use concentration techniques, such as the Strout method or the buffy coat (WHO 2018). The diagnosis in the acute phase is of extreme importance due to the high efficacy of the treatment at this phase. Once the chronic phase is established (asymptomatic or symptomatic), the parasitaemia gradually decreases, making it difficult to perform the direct parasitological diagnosis in blood. Xenodiagnosis is a classic method, which has been used in the chronic phase where few parasites are found in the blood. Uninfected triatomine bugs from laboratory colonies are allowed to feed on the patient. Afterwards, the bugs are dissected about 20-25 days after feeding and the hind gut contents are examined under the microscope for the presence of *T. cruzi* epimastigotes.

One of the great difficulties in the diagnosis of Chagas disease is that patients do not always have symptoms in the acute or chronic phase. Apart from that, in the chronic phase there is a high production of IgG-specific antibodies that are easily detectable by serological techniques. These antibodies, in most patients, will be present throughout life.

Among the different immunological methods available, the most used are ELISA, IFAT and indirect haemagglutination (IHA). Currently, there is no gold standard with 100% sensitivity and specificity,

so the serological diagnosis of certainty is based on the concordance of, at least, using two techniques with different principles and antigens. In addition, we must take into account that in endemic areas it can cross-react with non-pathogenic *Trypanosoma rangeli* or with *Leishmania* spp (WHO 2010). This is of special importance in the screening of blood donors due to potential transmission of Chagas disease through blood transfusion (WHO 2007, S. 2010).

Molecular PCR techniques have been considered as a promising alternative. However, the main problem arises in chronic patients where there is a low and sometimes intermittent parasitaemia or sometimes only a few parasites remain in some tissues. Different types of PCR have been used (nested, multiplex, PCR-hybridation), but their diagnostic value has been questioned since it is difficult to find a correlation with serological tests. Real-time PCR have been developed with greater sensitivity than previous methods. For the design of primers, the variable region of the minicircle kinetoplast DNA (kDNA), a repeat tandem sequence of nuclear DNA (stDNA), ribosomal RNA (rRNA) or the paraflagellar rod (PFR) genes have been used (Ramirez, Guhl et al. 2009, Schijman 2018).

It should be born in mind that seven genotypes have been described in *T. cruzi* that are called discrete typing units or DTUs (TcI-TcVI and Tcbat). These DTUs have substantial genetic diversity translated into differences in epidemiology and / or biological behaviour and should be taken into account when designing diagnostic techniques (Zingales 2018).

Despite the sensitivity and specificity of molecular techniques, their use in the diagnosis of trypanosomiasis in endemic countries is limited due to the high price of equipment needed and the shortage of qualified personnel. This is why LAMP can be a promising technique in these countries. Thekisoie et al., in 2007 developed different primers sets from 18S rRNA genes for *T. congolense* and *T. cruzi* and 5.8S rRNA-internal transcribed spacer 2 (ITS2) gene for *T. brucei gambiense* and VSG RoTat1.2 gene for *T. evansi* (REF). These LAMP first sets were highly sensitive and capable of detecting up to 1 fg trypanosomal DNA, which is equivalent to ~0.01% genomic DNA (Thekisoie, Kuboki et al. 2007). Thekisoie et al. also developed new assays for *T. cruzi* and *T. rangeli* targeting the 18S ribosomal RNA (rRNA) and small nucleolar RNA (snoRNA) genes (Thekisoie, Kuboki et al. 2007). This assay is able to differentiate between *T. cruzi* and *T. rangeli*, which is important considering that the latter is a non-pathogenic trypanosomatid that infects humans through the same vectors but leads to cross-reactions (Thekisoie, Rodriguez et al. 2010).

Recently, a LAMP *Trypanosoma cruzi* prototype kit has been developed by Besuschio et al., in collaboration with Eiken Chemical Co., Ltd. (Japan), the company that had previously developed a

LAMP kit for malaria and *Leishmania* (Besuschio, Llano Murcia et al. 2017). The repetitive satellite DNA sequence of *T. cruzi* was used as molecular target. This kit has the advantage that it uses reagents in dry form on the inside of the cap of the reaction tubes. The detection system is consisting of calcein that allows the direct visualization of the reaction by either naked-eye or fluorescence. Calcein is included in the reaction tubes in a quenched state, bound to manganese ions. The Bst DNA polymerase used in the LAMP reaction is not affected by blood and tissue-derived components such as myoglobin, heme-blood protein complexes and immunoglobulin G. In order to determine the sensitivity and specificity of the kit, purified DNA from different *T. cruzi* isolates was used. A validation of the kit was performed using a range of well-characterised blood samples from Chagas disease patients at different stages and with different clinical manifestations. Blood was included from seronegative donors as non-infected controls. Therefore, this prototype kit detects *T. cruzi* DNA at concentrations 1×10^{-2} fg/ μ L using purified DNA and 1×10^{-2} parasite equivalents/mL ("parasite equivalent" means the equivalent genomic content of one parasite cell) in extracts from spiked EDTA blood samples. The analytical sensitivity of this LAMP assay was superior to other studies using a LAMP procedure based on the 18S rDNA gene (Thekiso, Rodriguez et al. 2010, Rivero, Bisio et al. 2017).

8. FUTURE PERSPECTIVES AND CONCLUDING REMARKS

The control of malaria and other neglected diseases transmitted by vectors requires the application of different types of strategies ranging from vector control, diagnosis, treatment of patients to search for vaccines. Due to the measurements applied in the Millennium Development Goals (MDGs), the number of malaria deaths has been reduced by half in 2016, the incidence of African trypanosomiasis has been reduced to less than 3000 new cases in the world in 2015 and the transmission of kala-azar in the Indian sub-continent has also been diminished drastically (WHO 2018). However, we are still far from eradicating all these diseases, due to the emergence of parasite resistance to treatments, the resistance of vectors to insecticides and the maintenance of the parasite cycle due to reservoirs or asymptomatic individuals.

Therefore it is necessary to maintain the control of the different routes that lead to expansion of propagation of the disease. In this sense, the proper diagnosis of infected patients, especially the asymptomatic ones, is fundamental. The LAMP technique is a useful tool for diagnosis, because of its ease of use especially in regions of scarce resources where neglected diseases are endemic.

There are numerous studies aimed at developing systems that are highly sensitive, specific, affordable, easy and quick to use. The involvement of academic institutions such as universities and research centers together with non-profit organizations, such as Foundation for Innovative New Diagnostics (FIND) in the search and identification of target genes, evaluation of new detection systems, the development of integrated teams, maintenance of clinical trials platforms, bank sample management, etc. have generated very promising results to date. However, in order to ensure that these systems reach the patient, the involvement of companies is also necessary. In this sense Eiken Chemical Co has been the first one in developing one commercial LAMP kit for malaria with an affordable price (FIND 2018).

However, there are still a number of limitations in order to consider these systems as POCTs. Although integrated equipment are available able to undertake DNA extraction, amplification and detection, the size of the equipment is fundamental, so that it can be easily transported for use in remote areas. The Systems μ -Total Analysis System (μ -TAS) or "lab-on-a-chip" seem to be one of the most promising technologies (Notomi, Okayama et al. 2000, Choi, Song et al. 2016) in that respect along with the NINA-LAMP systems that do not require an electrical connection (Sema, Alemu et al. 2015).

Another handicap is the identification of the species responsible for the infection. Although some LAMP systems have been developed able to identify the parasites at the gender level or differentiate some species from others (for example *Pan/P. falciparum*), it is often necessary either to know the specific species to apply the most appropriate treatment or to determine if they are strains resistant to the usual drugs. LAMP would also be very useful in epidemiological studies to know the parasitic species in insect transmitters in order to apply vector control measurements. To this end, some researchers have proposed the incorporation of a small MinION™ type sequencer into the LAMP assay (Imai, Tarumoto et al. 2017).

Thinking of future emerging technologies, the next generation of molecular POCT devices should be able to connect to smart mobile phones being able to send the results to the clinician and the clinician to the patient in order to ensure a fast and suitable treatment. On the other hand, mobiles with global positioning would help in field epidemiological studies, providing information on the appearance and spread of new outbreaks and the effectiveness of control eradication programs (Song, Pandian et al. 2018).

REFERENCES

- Abbasi, I., O. D. Kirstein, A. Hailu and A. Warburg (2016). "Optimization of loop-mediated isothermal amplification (LAMP) assays for the detection of Leishmania DNA in human blood samples." *Acta Trop* **162**: 20-26.
- Adams, E. R., G. Schoone, I. Versteeg, M. A. Gomez, E. Diro, Y. Mori, D. Perlee, T. Downing, N. Saravia, A. Assaye, A. Hailu, A. Albertini, J. M. Ndung'u and H. Schallig (2018). "Development and Evaluation of a Novel Loop-Mediated Isothermal Amplification Assay for Diagnosis of Cutaneous and Visceral Leishmaniasis." *J Clin Microbiol* **56**(7).
- Adams, E. R., G. J. Schoone, A. F. Ageed, S. E. Safi and H. D. Schallig (2010). "Development of a reverse transcriptase loop-mediated isothermal amplification (LAMP) assay for the sensitive detection of Leishmania parasites in clinical samples." *Am J Trop Med Hyg* **82**(4): 591-596.
- Animation. (2018). "Eiken Chemical. Eiken genome site. Retrieved the 12 september 2018 from: <http://loopamp.eiken.co.jp/e/lamp/anim.html>."
- Besuschio, S. A., M. Llano Murcia, A. F. Benatar, S. Monnerat, I. Cruz, A. Picado, M. L. A. Curto, Y. Kubota, D. P. Wehrendt, P. Pavia, Y. Mori, C. Puerta, J. M. Ndung'u and A. G. Schijman (2017). "Analytical sensitivity and specificity of a loop-mediated isothermal amplification (LAMP) kit prototype for detection of Trypanosoma cruzi DNA in human blood samples." *PLoS Negl Trop Dis* **11**(7): e0005779.
- Britton, S., Q. Cheng, M. J. Grigg, C. B. Poole, C. Pasay, T. William, K. Fornace, N. M. Anstey, C. J. Sutherland, C. Drakeley and J. S. McCarthy (2016). "Sensitive Detection of Plasmodium vivax Using a High-Throughput, Colourimetric Loop Mediated Isothermal Amplification (HtLAMP) Platform: A Potential Novel Tool for Malaria Elimination." *PLoS Negl Trop Dis* **10**(2): e0004443.
- Britton, S., Q. Cheng, C. J. Sutherland and J. S. McCarthy (2015). "A simple, high-throughput, colourimetric, field applicable loop-mediated isothermal amplification (HtLAMP) assay for malaria elimination." *Malar J* **14**: 335.
- Bruce, K. L., S. C. Leterme, A. V. Ellis and C. E. Lenehan (2015). "Approaches for the detection of harmful algal blooms using oligonucleotide interactions." *Anal Bioanal Chem* **407**(1): 95-116.
- Carter, C., K. Akrami, D. Hall, D. Smith and E. Aronoff-Spencer (2017). "Lyophilized visually readable loop-mediated isothermal reverse transcriptase nucleic acid amplification test for detection Ebola Zaire RNA." *J Virol Methods* **244**: 32-38.
- CDC (2018). "Centers for disease control and prevention. Retrieved the 31 July 2018 from: <https://www.cdc.gov/parasites/about.html>."
- Choi, G., D. Song, S. Shrestha, J. Miao, L. Cui and W. Guan (2016). "A field-deployable mobile molecular diagnostic system for malaria at the point of need." *Lab Chip* **16**(22): 4341-4349.
- Cowman, A. F., J. Healer, D. Marapana and K. Marsh (2016). "Malaria: Biology and Disease." *Cell* **167**(3): 610-624.
- Cuadros, J., R. Perez-Tanoira, L. Prieto-Perez, I. Martin-Martin, P. Berzosa, V. Gonzalez, G. Tisiano, S. Balcha, J. M. Ramos and M. Gorgolas (2015). "Field Evaluation of Malaria Microscopy, Rapid Malaria Tests and Loop-Mediated Isothermal Amplification in a Rural Hospital in South Western Ethiopia." *PLoS One* **10**(11): e0142842.
- de Vries, H. J., S. H. Reedijk and H. D. Schallig (2015). "Cutaneous leishmaniasis: recent developments in diagnosis and management." *Am J Clin Dermatol* **16**(2): 99-109.
- Dinzouna-Boutamba, S. D., H. W. Yang, S. Y. Joo, S. Jeong, B. K. Na, N. Inoue, W. K. Lee, H. H. Kong, D. I. Chung, Y. K. Goo and Y. Hong (2014). "The development of loop-mediated isothermal amplification targeting alpha-tubulin DNA for the rapid detection of Plasmodium vivax." *Malar J* **13**: 248.
- Eiken (2018). "Eiken Chemical Co. Retrieved the 8 August 2018 from: <http://www.eiken.co.jp/en/product/lamp/index.html>."
- el Tai, N. O., O. F. Osman, M. el Fari, W. Presber and G. Schonian (2000). "Genetic heterogeneity of ribosomal internal transcribed spacer in clinical samples of Leishmania

donovani spotted on filter paper as revealed by single-strand conformation polymorphisms and sequencing." *Trans R Soc Trop Med Hyg* **94**(5): 575-579.

FIND (2018). "Foundation for Innovative New Diagnostics (FIND), Geneva, Switzerland; Eiken Chemicals Co. Ltd., Tokyo, Japan; and Hospital for Tropical Disease (HTD), London, United Kingdom. Manual of standard operating procedures for malaria LAMP DNA extraction methods 2012. Retrieved the 13 August 2018 from: <http://www.finddx.org/wp-content/uploads/2016/04/SOP-LAMP-Malaria-Aug2012.pdf>."

FIND (2018). "Negotiated product pricing. Retrieved the 13 August 2018 from: <https://www.finddx.org/find-negotiated-product-pricing/#http-lamp>."

Foley, M., L. C. Ranford-Cartwright and H. A. Babiker (1992). "Rapid and simple method for isolating malaria DNA from fingerprick samples of blood." *Mol Biochem Parasitol* **53**(1-2): 241-244.

Gandhi, P., S. Patil, S. Aher and A. Paradkar (2016). "Ultrasound-assisted preparation of novel ibuprofen-loaded excipient with improved compression and dissolution properties." *Drug Dev Ind Pharm* **42**(10): 1553-1563.

Garrido-Cardenas, J. A., C. Mesa-Valle and F. Manzano-Agugliaro (2018). "Human parasitology worldwide research." *Parasitology* **145**(6): 699-712.

Ghasemian, M., M. J. Gharavi, L. Akhlaghi, M. Mohebbi, A. R. Meamar, E. Aryan and H. Oormazdi (2014). "Development and Assessment of Loop-Mediated Isothermal Amplification (LAMP) Assay for the Diagnosis of Human Visceral Leishmaniasis in Iran." *Iran J Parasitol* **9**(1): 50-59.

Ghayour Najafabadi, Z., H. Oormazdi, L. Akhlaghi, A. R. Meamar, M. Nateghpour, L. Farivar and E. Razmjou (2014). "Detection of Plasmodium vivax and Plasmodium falciparum DNA in human saliva and urine: loop-mediated isothermal amplification for malaria diagnosis." *Acta Trop* **136**: 44-49.

Gonzalez, I. J., S. D. Polley, H. Hopkins, C. J. Sutherland, Y. Mori, M. Perkins and D. Bell (2011). "Molecular diagnosis for screening and elimination of malaria: performance of the first commercially-available malaria LAMP test." *Malar J* **11**(Suppl 1): O30.

Goto, M., E. Honda, A. Ogura, A. Nomoto and K. Hanaki (2009). "Colorimetric detection of loop-mediated isothermal amplification reaction by using hydroxy naphthol blue." *Biotechniques* **46**(3): 167-172.

Han, E. T. (2013). "Loop-mediated isothermal amplification test for the molecular diagnosis of malaria." *Expert Rev Mol Diagn* **13**(2): 205-218.

Han, E. T., R. Watanabe, J. Sattabongkot, B. Khuntirat, J. Sirichaisinthop, H. Iriko, L. Jin, S. Takeo and T. Tsuboi (2007). "Detection of four Plasmodium species by genus- and species-specific loop-mediated isothermal amplification for clinical diagnosis." *J Clin Microbiol* **45**(8): 2521-2528.

Hayashida, K., K. Kajino, L. Hachaambwa, B. Namangala and C. Sugimoto (2015). "Direct blood dry LAMP: a rapid, stable, and easy diagnostic tool for Human African Trypanosomiasis." *PLoS Negl Trop Dis* **9**(3): e0003578.

Hayashida, K., K. Kajino, H. Simukoko, M. Simuunza, J. Ndebe, A. Chota, B. Namangala and C. Sugimoto (2017). "Direct detection of falciparum and non-falciparum malaria DNA from a drop of blood with high sensitivity by the dried-LAMP system." *Parasit Vectors* **10**(1): 26.

Hopkins, H., I. J. González, S. D. Polley, P. Angutoko, J. Ategeka, C. Asiimwe, B. Agaba, D. J. Kyabayinze, C. J. Sutherland, M. D. Perkins and D. Bell (2013). "Highly sensitive detection of malaria parasitemia in a malaria-endemic setting: performance of a new loop-mediated isothermal amplification kit in a remote clinic in Uganda." *J Infect Dis* **208**(4).

Ibarra-Meneses, A. V., I. Cruz, C. Chicharro, C. Sanchez, S. Bieler, T. Broger, J. Moreno and E. Carrillo (2018). "Evaluation of fluorimetry and direct visualization to interpret results of a loop-mediated isothermal amplification kit to detect Leishmania DNA." *Parasit Vectors* **11**(1): 250.

Imai, K., N. Tarumoto, K. Misawa, L. R. Runtuwene, J. Sakai, K. Hayashida, Y. Eshita, R. Maeda, J. Tuda, T. Murakami, S. Maesaki, Y. Suzuki, J. Yamagishi and T. Maeda (2017). "A novel

diagnostic method for malaria using loop-mediated isothermal amplification (LAMP) and MinION™ nanopore sequencer." *BMC Infect Dis* **17**(1): 621.

Kadimisetty, K., J. Song, A. M. Doto, Y. Hwang, J. Peng, M. G. Mauk, F. D. Bushman, R. Gross, J. N. Jarvis and C. Liu (2018). "Fully 3D printed integrated reactor array for point-of-care molecular diagnostics." *Biosens Bioelectron* **109**: 156-163.

Karani, M., I. Sotiriadou, J. Plutzer and P. Karanis (2014). "Bench-scale experiments for the development of a unified loop-mediated isothermal amplification (LAMP) assay for the in vitro diagnosis of Leishmania species' promastigotes." *Epidemiol Infect* **142**(8): 1671-1677.

Khan, M. G., K. R. Bhaskar, M. A. Salam, T. Akther, G. Pluschke and D. Mondal (2012). "Diagnostic accuracy of loop-mediated isothermal amplification (LAMP) for detection of Leishmania DNA in buffy coat from visceral leishmaniasis patients." *Parasit Vectors* **5**: 280.

Lau, Y. L., M. Y. Fong, R. Mahmud, P. Y. Chang, V. Palaeya, F. W. Cheong, L. C. Chin, C. N. Anthony, A. M. Al-Mekhlafi and Y. Chen (2011). "Specific, sensitive and rapid detection of human plasmodium knowlesi infection by loop-mediated isothermal amplification (LAMP) in blood samples." *Malar J* **10**: 197.

Lau, Y. L., M. Y. Lai, M. Y. Fong, J. Jelip and R. Mahmud (2016). "Loop-Mediated Isothermal Amplification Assay for Identification of Five Human Plasmodium Species in Malaysia." *Am J Trop Med Hyg* **94**(2): 336-339.

Lee, K. S., J. Cox-Singh and B. Singh (2009). "Morphological features and differential counts of Plasmodium knowlesi parasites in naturally acquired human infections." *Malar J* **8**: 73.

Lu, F., Q. Gao, H. Zhou, J. Cao, W. Wang, C. S. Lim, S. Na, T. Tsuboi and E. T. Han (2012). "Molecular test for vivax malaria with loop-mediated isothermal amplification method in central China." *Parasitol Res* **110**(6): 2439-2444.

Lucchi, N. W., A. Demas, J. Narayanan, D. Sumari, A. Kabanywany, S. P. Kachur, J. W. Barnwell and V. Udhayakumar (2010). "Real-time fluorescence loop mediated isothermal amplification for the diagnosis of malaria." *PLoS One* **5**(10): e13733.

Lucchi, N. W., D. Ljolje, L. Silva-Flannery and V. Udhayakumar (2016). "Use of Malachite Green-Loop Mediated Isothermal Amplification for Detection of Plasmodium spp. Parasites. ." *PLoS One* **11**(3): e0151437.

Mabey, D., R. W. Peeling, A. Ustianowski and M. D. Perkins (2004). "Diagnostics for the developing world." *Nat Rev Microbiol* **2**(3): 231-240.

Mao, R., G. Ge, Z. Wang, R. Hao, G. Zhang, Z. Yang, B. Lin, Y. Ma, H. Liu and Y. Du (2018). "A multiplex microfluidic loop-mediated isothermal amplification array for detection of malaria-related parasites and vectors." *Acta Trop* **178**: 86-92.

Marti, H., C. Stalder and I. J. González (2015). "Diagnostic accuracy of a LAMP kit for diagnosis of imported malaria in Switzerland. ." *Travel Med Infect Dis* **13**(2): 167-171.

Merino-Espinosa, G., V. Corpas-Lopez, V. Diaz-Saez, F. Morillas-Marquez, J. Tercedor-Sanchez, J. M. Azana-Defez, J. Lopez-Hidalgo, J. Aneiros-Fernandez and J. Martin-Sanchez (2018). "Cutaneous leishmaniasis by Leishmania infantum: behind granulomatous lesions of unknown aetiology." *Journal of the European Academy of Dermatology and Venereology* **32**(1): 117-124.

Modak, S. S., C. A. Barber, E. Geva, W. R. Abrams, D. Malamud and Y. S. Ongagna (2016). "Rapid Point-of-Care Isothermal Amplification Assay for the Detection of Malaria without Nucleic Acid Purification." *Infect Dis (Auckl)* **9**: 1-9.

Mohon, A. N., R. Elahi, W. A. Khan, R. Haque, D. J. Sullivan, Jr. and M. S. Alam (2014). "A new visually improved and sensitive loop mediated isothermal amplification (LAMP) for diagnosis of symptomatic falciparum malaria." *Acta Trop* **134**: 52-57.

Momcilovic, S., C. Cantacessi, V. Arsic-Arsenijevic, D. Otranto and S. Tasic-Otasevic (2018). "Rapid diagnosis of parasitic diseases: current scenario and future needs." *Clin Microbiol Infect*.

Moody, A. (2002). "Rapid diagnostic tests for malaria parasites." *Clin Microbiol Rev* **15**(1): 66-78.

Moore, R. A., P. J. Wiffen, S. Derry, T. Maguire, Y. M. Roy and L. Tyrrell (2015). "Non-prescription (OTC) oral analgesics for acute pain - an overview of Cochrane reviews." Cochrane Database Syst Rev(11): CD010794.

Mori, Y., K. Nagamine, N. Tomita and T. Notomi (2001). "Detection of loop-mediated isothermal amplification reaction by turbidity derived from magnesium pyrophosphate formation." Biochem Biophys Res Commun **289**(1): 150-154.

Morris, U., M. Khamis, B. Aydin-Schmidt, A. K. Abass, M. I. Msellem, M. H. Nassor, I. J. Gonzalez, A. Martensson, A. S. Ali, A. Bjorkman and J. Cook (2015). "Field deployment of loop-mediated isothermal amplification for centralized mass-screening of asymptomatic malaria in Zanzibar: a pre-elimination setting." Malar J **14**: 205.

Mukhtar, M., S. S. Ali, S. A. Boshara, A. Albertini, S. Monnerat, P. Bessell, Y. Mori, Y. Kubota, J. M. Ndung'u and I. Cruz (2018). "Sensitive and less invasive confirmatory diagnosis of visceral leishmaniasis in Sudan using loop-mediated isothermal amplification (LAMP)." PLoS Negl Trop Dis. **12**(2): e0006264.

Nagamine, K., T. Hase and T. Notomi (2002). "Accelerated reaction by loop-mediated isothermal amplification using loop primers." Mol Cell Probes **16**(3): 223-229.

Ndao, M. (2009). "Diagnosis of parasitic diseases: old and new approaches." Interdiscip Perspect Infect Dis **2009**: 278246.

Njiru, Z. K. (2012). "Loop-mediated isothermal amplification technology: towards point of care diagnostics." PLoS Negl Trop Dis **6**(6): e1572.

Notomi, T., H. Okayama, H. Masubuchi, T. Yonekawa, K. Watanabe, N. Amino and T. Hase (2000). "Loop-mediated isothermal amplification of DNA." Nucleic Acids Res **28**(12): E63.

Nzelu, C. O., A. G. Caceres, S. Guerrero-Quincho, E. Tineo-Villafuerte, L. Rodriguez-Delfin, T. Mimori, H. Uezato, K. Katakura, E. A. Gomez, A. G. Guevara, Y. Hashiguchi and H. Kato (2016). "A rapid molecular diagnosis of cutaneous leishmaniasis by colorimetric malachite green-loop-mediated isothermal amplification (LAMP) combined with an FTA card as a direct sampling tool." Acta Trop **153**: 116-119.

Oriero, C. E., J. P. van Geertruyden, J. Jacobs, U. D'Alessandro and D. Nwakanma (2015). "Validation of an apicoplast genome target for the detection of Plasmodium species using polymerase chain reaction and loop mediated isothermal amplification. ." Clin Microbiol Infect. **21**(7): 686:e681-687.

Oriero, E. C., J. Okebe, J. Jacobs, J. P. Van Geertruyden, D. Nwakanma and U. D'Alessandro (2015). "Diagnostic performance of a novel loop-mediated isothermal amplification (LAMP) assay targeting the apicoplast genome for malaria diagnosis in a field setting in sub-Saharan Africa." Malar J **14**: 396.

Parida, M., S. Sannarangaiah, P. K. Dash, P. V. Rao and K. Morita (2008). "Loop mediated isothermal amplification (LAMP): a new generation of innovative gene amplification technique; perspectives in clinical diagnosis of infectious diseases." Rev Med Virol **18**(6): 407-421.

Paris, D. H., M. Imwong, A. M. Faiz, M. Hasan, E. B. Yunus, K. Silamut, S. J. Lee, N. P. Day and A. M. Dondorp (2007). "Loop-mediated isothermal PCR (LAMP) for the diagnosis of falciparum malaria." Am J Trop Med Hyg **77**(5): 972-976.

Patel, J. C., N. W. Lucchi, P. Srivastava, J. T. Lin, R. Sug-Aram, S. Aruncharus, P. K. Bharti, M. M. Shukla, K. Congpuong, W. Satimai, N. Singh, V. Udhayakumar and S. R. Meshnick (2014). "Field evaluation of a real-time fluorescence loop-mediated isothermal amplification assay, RealAmp, for the diagnosis of malaria in Thailand and India." J Infect Dis **210**(8): 1180-1187.

Patel, J. C., J. Oberstaller, M. Xayavong, J. Narayanan, J. D. DeBarry, G. Srinivasamoorthy, L. Villegas, A. A. Escalante, A. DaSilva, D. S. Peterson, J. W. Barnwell, J. C. Kissinger, V. Udhayakumar and N. W. Lucchi (2013). "Real-time loop-mediated isothermal amplification (RealAmp) for the species-specific identification of Plasmodium vivax. ." PLoS One **8**(1): e54986.

Polley, S. D., Y. Mori, J. Watson, M. D. Perkins, I. J. González, T. Notomi, P. L. Chiodini and C. J. Sutherland (2010). "Mitochondrial DNA targets increase sensitivity of malaria detection using loop-mediated isothermal amplification." *J Clin Microbiol* **48**(8): 2866-2871.

Poole, C. B., N. A. Tanner, Y. Zhang, T. C. Evans, Jr. and C. K. Carlow (2012). "Diagnosis of brugian filariasis by loop-mediated isothermal amplification." *PLoS Negl Trop Dis* **6**(12): e1948.

Poon, L. L., B. W. Wong, E. H. Ma, K. H. Chan, L. M. Chow, W. Abeyewickreme, N. Tangpukdee, K. Y. Yuen, Y. Guan, S. Looareesuwan and J. S. Peiris (2006). "Sensitive and inexpensive molecular test for falciparum malaria: detecting Plasmodium falciparum DNA directly from." *Clin Chem* **52**(2): 303-306.

Port, J. R., C. Nguetse, S. Adukpo and T. P. Velavan (2014). "A reliable and rapid method for molecular detection of malarial parasites using microwave irradiation and loop mediated isothermal amplification." *Malar J* **13**: 454.

Port, J. R., C. Nguetse, S. Adukpo and T. P. Velavan (2014). "A reliable and rapid method for molecular detection of malarial parasites using microwave irradiation and loop mediated isothermal amplification." *Malar J* **13**(454).

Poschl, B., J. Waneesorn, O. Thekisoe, S. Chutipongvivate and P. Karanis (2010). "Comparative diagnosis of malaria infections by microscopy, nested PCR, and LAMP in northern Thailand." *Am J Trop Med Hyg* **83**(1): 56-60.

Ramirez, J. D., F. Guhl, E. S. Umezawa, C. A. Morillo, F. Rosas, J. A. Marin-Neto and S. Restrepo (2009). "Evaluation of adult chronic Chagas' heart disease diagnosis by molecular and serological methods." *J Clin Microbiol* **47**(12): 3945-3951.

Rivero, R., M. Bisio, E. B. Velazquez, M. I. Esteva, K. Scollo, N. L. Gonzalez, J. Altcheh and A. M. Ruiz (2017). "Rapid detection of Trypanosoma cruzi by colorimetric loop-mediated isothermal amplification (LAMP): A potential novel tool for the detection of congenital Chagas infection." *Diagn Microbiol Infect Dis* **89**(1): 26-28.

Rypien, C., B. Chow, W. W. Chan, D. L. Church and D. R. Pillai (2017). "Detection of Plasmodium Infection by the illumigene Malaria Assay Compared to Reference Microscopy and Real-Time PCR." *J Clin Microbiol* **55**(10): 3037-3045.

S., W. (2010). "Transfusion transmitted Chagas disease: is it really under control?" *Acta Trop* **115**(1-2): 28-34.

Sattabongkot, J., T. Tsuboi, E. T. Han, S. Bantuchai and S. Buates (2014). "Loop-mediated isothermal amplification assay for rapid diagnosis of malaria infections in an area of endemicity in Thailand." *J Clin Microbiol* **52**(5): 1471-1477.

Schijman, A. G. (2018). "Molecular diagnosis of Trypanosoma cruzi." *Acta Trop* **184**: 59-66.

Schmitt, B. H., J. E. Rosenblatt and B. S. Pritt (2012). "Laboratory diagnosis of tropical infections." *Infect Dis Clin North Am* **26**(2): 513-554.

Sema, M., A. Alemu, A. G. Bayih, S. Getie, G. Getnet, D. Guelig, R. Burton, P. LaBarre and D. R. Pillai (2015). "Evaluation of non-instrumented nucleic acid amplification by loop-mediated isothermal amplification (NINA-LAMP) for the diagnosis of malaria in Northwest Ethiopia." *Malar J* **14**: 44.

Silveira, F. T., R. Lainson and C. E. Corbett (2004). "Clinical and immunopathological spectrum of American cutaneous leishmaniasis with special reference to the disease in Amazonian Brazil: a review." *Mem Inst Oswaldo Cruz* **99**(3): 239-251.

Singh, O. P. and S. Sundar (2015). "Developments in Diagnosis of Visceral Leishmaniasis in the Elimination Era." *J Parasitol Res* **2015**: 239469.

Singh, R., D. P. Singh, D. Savargaonkar, O. P. Singh, R. M. Bhatt and N. Valecha (2017). "Evaluation of SYBR green I based visual loop-mediated isothermal amplification (LAMP) assay for genus and species-specific diagnosis of malaria in P. vivax and P. falciparum endemic regions." *J Vector Borne Dis* **54**(1): 54-60.

Song, J., V. Pandian, M. G. Mauk, H. H. Bau, S. Cherry, L. C. Tisi and C. Liu (2018). "Smartphone-Based Mobile Detection Platform for Molecular Diagnostics and Spatiotemporal Disease Mapping." *Anal Chem* **90**(7): 4823-4831.

Srividya, G., A. Kulshrestha, R. Singh and P. Salotra (2012). "Diagnosis of visceral leishmaniasis: developments over the last decade." *Parasitol Res* **110**(3): 1065-1078.

Sriworarat, C., A. Phumee, M. Mungthin, S. Leelayoova and P. Siriyasatien (2015). "Development of loop-mediated isothermal amplification (LAMP) for simple detection of Leishmania infection." *Parasit Vectors* **8**: 591.

Takagi, H., M. Itoh, M. Z. Islam, A. Razzaque, A. R. Ekram, Y. Hashighuchi, E. Noiri and E. Kimura (2009). "Sensitive, specific, and rapid detection of Leishmania donovani DNA by loop-mediated isothermal amplification." *Am J Trop Med Hyg* **81**(4): 578-582.

Tanner, N. A., Y. Zhang and T. C. Evans, Jr. (2012). "Simultaneous multiple target detection in real-time loop-mediated isothermal amplification." *Biotechniques* **53**(2): 81-89.

Tao, Z. Y., H. Y. Zhou, H. Xia, S. Xu, H. W. Zhu, R. L. Culleton, E. T. Han, F. Lu, Q. Fang, Y. P. Gu, Y. B. Liu, G. D. Zhu, W. M. Wang, J. L. Li, J. Cao and Q. Gao (2011). "Adaptation of a visualized loop-mediated isothermal amplification technique for field detection of Plasmodium vivax infection." *Parasit Vectors* **4**: 115.

Tegegne, B., S. Getie, W. Lemma, A. N. Mohon and D. R. Pillai (2017). "Performance of loop-mediated isothermal amplification (LAMP) for the diagnosis of malaria among malaria suspected pregnant women in Northwest Ethiopia." *Malar J* **16**(1): 34.

Thekiso, O. M., R. S. Bazie, A. M. Coronel-Servian, C. Sugimoto, S. Kawazu and N. Inoue (2009). "Stability of Loop-Mediated Isothermal Amplification (LAMP) reagents and its amplification efficiency on crude trypanosome DNA templates." *J Vet Med Sci* **71**(4): 471-475.

Thekiso, O. M., N. Kuboki, A. Nambota, K. Fujisaki, C. Sugimoto, I. Igarashi, J. Yasuda and N. Inoue (2007). "Species-specific loop-mediated isothermal amplification (LAMP) for diagnosis of trypanosomiasis." *Acta Trop* **102**(3): 182-189.

Thekiso, O. M., C. V. Rodriguez, F. Rivas, A. M. Coronel-Servian, S. Fukumoto, C. Sugimoto, S. Kawazu and N. Inoue (2010). "Detection of Trypanosoma cruzi and T. rangeli infections from Rhodnius pallescens bugs by loop-mediated isothermal amplification (LAMP)." *Am J Trop Med Hyg* **82**(5): 855-860.

Tomita, N., Y. Mori, H. Kanda and T. Notomi (2008). "Loop-mediated isothermal amplification (LAMP) of gene sequences and simple visual detection of products." *Nat Protoc* **3**(5): 877-882.

Ushikubo, H. (2004). "[Principle of LAMP method--a simple and rapid gene amplification method]." *Uirusu* **54**(1): 107-112.

Vallejo, A. F., N. L. Martinez, I. J. Gonzalez, M. Arevalo-Herrera and S. Herrera (2015). "Evaluation of the loop mediated isothermal DNA amplification (LAMP) kit for malaria diagnosis in P. vivax endemic settings of Colombia." *PLoS Negl Trop Dis* **9**(1): e3453.

Verma, S., K. Avishek, V. Sharma, N. S. Negi, V. Ramesh and P. Salotra (2013). "Application of loop-mediated isothermal amplification assay for the sensitive and rapid diagnosis of visceral leishmaniasis and post-kala-azar dermal leishmaniasis." *Diagn Microbiol Infect Dis* **75**(4): 390-395.

Waller, R. F. and G. I. McFadden (2005). "The apicoplast: a review of the derived plastid of apicomplexan parasites." *Curr Issues Mol Biol* **7**(1): 57-79.

WHO (2007). "World Health Organization. WHO Consultation on International Biological Reference Preparations for Chagas Diagnostic Tests. Retrieved the 8 August 2018 from: http://www.who.int/bloodproducts/ref_materials/WHO_Report_1st_Chagas_BRP_consultation_7-2007_final.pdf."

WHO (2010). "Anti-trypanosoma cruzi assays: operational characteristics, report 1. World Health Organization. Retrieved the 8 August 2018 from: http://www.who.int/diagnostics_laboratory/publications/anti_t_cruzi_assays.pdf."

WHO (2018). "Chagas diagnosis. Retrieved the 20 August from: http://www.who.int/chagas/home_diagnosis_more_definitions/en/."

WHO (2018). "Malaria. Retrieved the 20 August from: <http://www.who.int/malaria/publications/rdt-manual/en/>."

WHO (2018). "Millennium Development Goals (MDGs).. Retrieved the 13 August 2018 from: [http://www.who.int/en/news-room/fact-sheets/detail/millennium-development-goals-\(mdgs\)](http://www.who.int/en/news-room/fact-sheets/detail/millennium-development-goals-(mdgs))."

WHO (2018). "Prevalence of trypanosomiasis. Retrieved the 8 August 2018 from: [http://www.who.int/es/news-room/fact-sheets/detail/chagas-disease-\(american-trypanosomiasis\)](http://www.who.int/es/news-room/fact-sheets/detail/chagas-disease-(american-trypanosomiasis))."

WHO (2018). "WHO Malaria screening. Retrieved the 13 August 2018 from: <http://www.who.int/malaria/areas/diagnosis/rapid-diagnostic-tests/role-in-malaria-control/en/>."

WHO (2018). "WHO Malaria. Retrieved the 13 August 2018 from: <http://www.who.int/en/news-room/fact-sheets/detail/malaria>."

WHO (2018). "WHO. Clinical manifestations of leishmaniasis. Retrieved the 7 August 2018 from: <http://www.who.int/es/news-room/fact-sheets/detail/leishmaniasis>."

Wooden, J., S. Kyes and C. H. Sibley (1993). "PCR and strain identification in *Plasmodium falciparum*." *Parasitol Today* **9**(8): 303-305.

Yamamura, M., K. Makimura and Y. Ota (2009). "Evaluation of a new rapid molecular diagnostic system for *Plasmodium falciparum* combined with DNA filter paper, loop-mediated isothermal amplification, and melting curve analysis." *Jpn J Infect Dis* **62**(1): 20-25.

Yongkiettrakul, S., W. Jaroenram, N. Arunrut, W. Chareanchim, S. Pannengpetch, R. Suebsing, W. Kiatpathomchai, W. Pornthanakasem, Y. Yuthavong and D. Kongkasuriyachai (2014). "Application of loop-mediated isothermal amplification assay combined with lateral flow dipstick for detection of *Plasmodium falciparum* and *Plasmodium vivax*." *Parasitol Int* **63**(6): 777-784.

Zhang, X., S. B. Lowe and J. J. Gooding (2014). "Brief review of monitoring methods for loop-mediated isothermal amplification (LAMP)." *Biosens Bioelectron* **61**: 491-499.

Zijlstra, E. E. (2016). "The immunology of post-kala-azar dermal leishmaniasis (PKDL)." *Parasit Vectors* **9**: 464.

Zingales, B. (2018). "Trypanosoma cruzi genetic diversity: Something new for something known about Chagas disease manifestations, serodiagnosis and drug sensitivity." *Acta Trop* **184**: 38-52.