



City Research Online

City, University of London Institutional Repository

Citation: Qian, K., Zhang, X-D., Fu, F. ORCID: 0000-0002-9176-8159 and Li, B. (2018). Progressive Collapse Resisting Mechanisms of Planar Prestressed Concrete Frame. ACI Structural Journal,

This is the accepted version of the paper.

This version of the publication may differ from the final published version.

Permanent repository link: <http://openaccess.city.ac.uk/20686/>

Link to published version:

Copyright and reuse: City Research Online aims to make research outputs of City, University of London available to a wider audience. Copyright and Moral Rights remain with the author(s) and/or copyright holders. URLs from City Research Online may be freely distributed and linked to.

City Research Online:

<http://openaccess.city.ac.uk/>

publications@city.ac.uk

1
2
3 1 loss of a middle column. The six tests consist of two non-prestressed reinforced concrete
4
5 2 (RC) specimens and four prestressed concrete (PC) specimens with bonded post-tensioning
6
7 3 tendons (BPT). The structural response of the specimens with different flexural reinforcement
8
9 4 ratio, span/depth ratio, and effective prestress level has been reported. In addition, the impact
10
11 5 of parabolic BPT on the behavior of RC frames to resist progressive collapse is also
12
13 6 evaluated. Experimental results indicated that the BPT can not only increase the initial
14
15 7 stiffness and yielding load of the RC counterparts, but also increase the ultimate load capacity
16
17 8 in the catenary action stage. Moreover, it will impact the load resisting mechanisms and the
18
19 9 failure modes. Contrary to the commonly accepted sequential mobilization of compressive
20
21 10 arch action and catenary action to resist progressive collapse of RC frames, no effective
22
23 11 compressive arch action is developed in PC frames to mitigate progressive collapse risk.
24
25 12 Based on experimental observations, it is found that higher effective prestress in BPT results
26
27 13 in enhanced initial stiffness and yielding load but less deformation capacity and ultimate load
28
29 14 capacity. It is also found that higher non-prestressed flexural tensile reinforcement ratio could
30
31 15 improve the behavior of PC specimens to resist progressive collapse.
32
33
34
35
36
37
38
39

40 17 **Keywords:** progressive collapse; prestressed concrete; compressive arch action; catenary
41
42 18 action; mechanism; bonded; post-tensioning tendon.
43
44
45
46
47
48

49 21 INTRODUCTION

50
51 22 Progressive collapse is defined as “the spread of an initial local failure from element to
52
53 23 element, which eventually results in the collapse of an entire structure or a disproportionately
54
55 24 large part of it”¹. As the accidents or terrorist attacks are unpredictable, conventional civil
56
57 25 structures cannot be risk-free. Thus, one of the most popular topics in structural engineering
58
59
60

1
2
3 1 in the last decade is evaluating the behavior and load resisting mechanism of different types
4
5 2 of building structures to mitigate progressive collapse risk. Currently, the commonly used
6
7 3 method to evaluate the progressive collapse resistance of structures is based on the remaining
8
9 4 structures following initial local failure such as the loss of a load bearing column or partial of
10
11 5 walls²⁻⁴. Alternate load path method is popular used for progressive collapse design⁵⁻⁹. Based
12
13 6 on alternate load path method, a number of tests²⁻¹¹ had been carried out. All foregoing test
14
15 7 results²⁻¹¹ demonstrated that considerable compressive arch action could enhance the yielding
16
17 8 load capacity of reinforced concrete (RC) beams in relatively small deformation stage while
18
19 9 catenary action could develop in beam longitudinal reinforcements in large deformation
20
21 10 stage. These tests are focused on RC frames and thus, their conclusions may not be able to
22
23 11 refer for designing of prestressed concrete (PC) frames to mitigate progressive collapse
24
25 12 effectively. As well known, nowadays, PC technique is frequently used in commercial
26
27 13 buildings with long spans. Parabolic tendons with drapes are commonly installed in the
28
29 14 continuous beams to apply pre-compression force in the expected tensile zone, as shown in
30
31 15 **Fig. 1a**. However, the bending moment reversal will occur in the beams after removal of the
32
33 16 middle column: such as the initial hogging moment in the beam end at the location of the
34
35 17 middle column changes to sagging moment after removal of the column, as shown in **Fig. 1b**.
36
37 18 If a middle column is removed accidentally, the profile of tendons will differ with the
38
39 19 bending moment distribution along the beams. It is well known that the PC frames are
40
41 20 shallower in depth than their RC counterparts with the same span and loading conditions.
42
43 21 Thus, the PC frames may have higher possibility to trigger progressive collapse when the
44
45 22 profile of prestressing tendons deviate its design purpose after accidentally removal of the
46
47 23 columns. Therefore, it is imperative to carry out the investigations to capture the behavior of
48
49 24 PC frames under the removal of a middle column. However, limited studies, especially
50
51 25 experimental tests, have had been conducted on the capacity of PC frames to mitigate
52
53
54
55
56
57
58
59
60

1 progressive collapse.

2 The behaviour of PC frame with unbonded post-tensioning (UPT) tendons was investigated
3 by Qian *et al.*¹². It is well known, for unbonded tendons transfer the force to the concrete via
4 the end anchors and the profile of tendons. However, the force of bonded tendons can be
5 transferred to the concrete through the bond between the tendons and concrete. Thus, the PC
6 frames with bonded tendons may behave quite differently to unbonded tendons¹³. Therefore,
7 the previous work of Qian *et al.*¹² has been extended to carry out a programme of tests on PC
8 beam-column subassemblages with bonded post-tensioning tendons (BPT), which will be
9 presented in this paper.

11 **RESEARCH SIGNIFICANCE**

12 The stress profile of tendons may differ with the bending moment distribution after removal
13 of a middle column, which may result in possible collapse of PC frame. To quantify the
14 possible load resisting mechanisms of PC frames subjected to a middle column missing
15 scenario, a series of four PC beam-column subassemblages with BPT are tested in this study.
16 By comparing to conventional RC subassemblages and PC subassemblages with UPT, the
17 effects on BPT could be evaluated quantitatively. Due to no special provisions in existing
18 guidelines (GSA¹⁴ and DoD¹⁵) for mitigating the progressive collapse risk of PC frame, the
19 test results may provide necessary research outcome to fill the gap. Moreover, this research
20 extends the availability of benchmarking data for the development of reliable analytical or
21 numerical models as limited test data are available in literature.

22 **EXPERIMENTAL PROGRAM**

23 **Test Specimen**

24 Six specimens are designed and constructed to investigate the performance of PC beam-
25 column sub-assemblages with BPT to resist progressive collapse caused by the loss of a

1
2
3 1 middle column due to blast or vehicular impact. These six specimens include four PC beam-
4
5 2 column subassemblages (PCSL-0.6, PCSL-0.75, PCSH-0.6, and PCLL-0.6) and two non-
6
7 3 prestressed RC counterparts (RCSL and RCLL). For example, the designation of PCSL-0.6
8
9 4 represents PC specimen with short span (span/depth ratio of 12), low amount of non-
10
11 5 prestressed reinforcement, and the effective prestress (f_{pe}) of $0.6f_{pu}$, where f_{pu} is the ultimate
12
13 6 strength of the tendon. Similarly, the designation of RCSL represents non-prestressed RC
14
15 7 specimen with short span and low longitudinal reinforcement ratio. **Table 1** gives the
16
17 8 designation and characteristics of each specimen. The specimens are one-half scaled due to
18
19 9 facility capacity in laboratory. The prototype frame of the specimens is located at the middle
20
21 10 of a perimeter frame of a six story office building, which has 4.2 m and 3.3 m high in the first
22
23 11 and upper story, respectively. The design span is 6 m and 7 m for prototype frame with short
24
25 12 and long span, respectively. The RC detail of the specimens are following the seismic design
26
27 13 requirement in accordance with ACI 318-14¹⁶ and assumed to be located on a D class site
28
29 14 (stiff soil profile) where the design spectral response acceleration parameters, S_{DS} and S_{D1} ,
30
31 15 are 0.45 and 0.30, respectively. The live load (LL) is assumed to be 2.0 kPa while the dead
32
33 16 load (DL) including the self-weight is assumed to be 3.75 kPa. As shown in **Fig. 2**, each
34
35 17 specimen comprises of two side columns, one middle column, and two beams. All specimens
36
37 18 are half-scaled due to capacity limits of the test facilities. The cross-section of beam and
38
39 19 middle column are 150 mm×250 mm (2.9 in.×9.8 in.) and 250 mm×250 mm (9.8 in.×9.8 in.),
40
41 20 respectively. However, the size of side column is enlarged to 400 mm×400 mm (15.7 in.×15.7
42
43 21 in.) for applying fixed boundary conditions well. For Specimen PCSL-0.6, the beam non-
44
45 22 prestressed reinforcements of 3T10 are installed in both top and bottom layer, which
46
47 23 corresponds to reinforcement ratio of 0.7%. The reinforcements are placed in the beam
48
49 24 continuously. T10 and R6 herein represent deformed reinforcement with diameter of 10 mm
50
51 25 (0.4 in.) and plain reinforcement with diameter of 6 mm (0.2 in.), respectively. As shown in
52
53
54
55
56
57
58
59
60

the figure, a plastic duct with internal diameter of 32 mm (1.3 in.) is installed with parabolic profile before casting. After erected the specimen in the setup, a tendon with nominal diameter of 12.7 mm (0.5 in.) is threaded through the duct and jacked it to target effective prestress $0.6f_{pu}$. Following that, grouting is conducted immediately. To ensure effective bonding between BPT and concrete, each specimen is tested after grouting over least three days. The true effective prestress of BPT deducting the prestress loss are measured and tabulated in **Table 1**. The tendon is twisted by seven high-strength wires with nominal area of 98 mm^2 (0.2 in^2). The parabolic profile of the tendon is following Eqs. 1 and 2.

$$y_1 = 0.12x_1^2 \quad (1)$$

$$y_2 = 0.28x_2^2 \quad (2)$$

where y_1 is the vertical coordinate of the tendon from the origin in the middle of the beam, x_1 is the horizontal coordinate of the tendon from the origin in the middle of the beam, y_2 is the vertical coordinate of the tendon from the origin in the middle of the center column, and x_2 is the horizontal coordinate of the tendon from the origin in the middle of the center column.

PCSL-0.75 has identical dimensions and reinforcement details as PCSL-0.6 but higher designated effective prestress $0.75f_{pu}$. Comparing to PCSL-0.6, PCSH-0.6 has higher non-prestressed reinforcement ratio. In PCSH-0.6, the top and bottom beam longitudinal reinforcement are 3T12 in accordance with reinforcement ratio of 1.0 %. For PCLL-0.6, it has similar cross-section and reinforcement details as PCSL-0.6. However, it has longer design span of 3500 mm (137.8 in.) and larger span/depth ratio of 14, as shown in **Fig. 2c**. For comparison easily, two non-prestressed RC specimens (RCSL and RCLL) without BPT are also cast and tested. Specimens RCSL and RCLL have similar dimensions and reinforcement details as the corresponding PC Specimens PCSL-0.6 and PCLL-0.6, respectively.

Based on compressive cylindrical tests, the measured concrete compressive strength of

1
2
3 1 RCSL, RCLL, PCSL-0.6, PCSL-0.75, PCSH-0.6, and PCLL-0.6 are 44 MPa (6 kip), 44 MPa
4
5 2 (6 kip), 45 MPa (6 kip), 44 MPa (6 kip), 45 MPa (7 kip), and 43 MPa (6 kip), respectively.
6
7 3 Furthermore, based on tensile splitting tests, the tensile strength of the concrete of RCSL,
8
9 4 RCLL, PCSL-0.6, PCSL-0.75, PCSH-0.6, and PCLL-0.6 are 3.1 MPa (0.4 kip), 3.3 MPa (0.5
10
11 5 kip), 3.0 MPa (0.4 kip), 3.5 MPa (0.5 kip), 3.1 MPa (0.4 kip), and 3.4 MPa (0.5 kip),
12
13 6 respectively. The properties of reinforcements and strands are tabulated in **Table 2**.
14
15

16 17 **Test setup and instrumentation**

18
19 8 Similar to previous tests²⁻⁵, as shown in **Fig. 3**, the side column is substituted with fixed
20
21 9 boundary conditions by two horizontal constraints and a pin support. To eliminate the
22
23 10 redundant horizontal constraints from the pin support, a series of steel rollers are mounted
24
25 11 below it. A hydraulic jack (lower jack) is installed below the middle column stub to release of
26
27 12 the axial force manually. The stroke of the jack is initially protruded out to touch the bottom
28
29 13 of the middle column stub for simulation of the ground middle column intact. Then, six steel
30
31 14 weight assemblages with weight of 5000 kg (11.0 klb) are hung below the beams to simulate
32
33 15 the design service load (DL+LL). Once the weights are hung completely and the
34
35 16 instrumentations are ready to record data, the stroke of the lower jack is retracted gradually to
36
37 17 release its axial force slowly. If the specimen could stabilize after the stroke of the lower jack
38
39 18 detaches from the bottom of the middle column stub completely, the stroke of upper jack
40
41 19 begins to protrude out to apply additional concentrated force on the middle column until
42
43 20 collapse. To eliminate the out-of-plane failure of the two-dimensional (2D) beam-column
44
45 21 sub-assemblages, a special designed steel assembly is installed underneath the upper jack.
46
47 22 The steel assembly is consisted of a steel box and several steel pins to only allow vertical
48
49 23 movement of the middle column but constraints its rotation and horizontal movements. A
50
51 24 series of displacement transducers and load cells are installed to monitor the behavior of the
52
53 25 specimens. As shown in **Fig. 3b**, load cell #3 is utilized to measure the axial force in the
54
55
56
57
58
59
60

1 lower jack. Load cells #1 and #2 are used to measure the applied additional concentrated
2 force from upper jack. Moreover, the vertical load redistribution is measured by the load cells
3 #4 and #5. To monitor the variation of prestressing force in the tendon, load cell #6 is
4 installed at the jacking end. Tension/compression load cells are installed in the horizontal
5 constraints to measure the horizontal reaction applied on the side columns. Displacement
6 transducers D1 to D7 are installed to measure the variation of the deformation shape of the
7 beam. Before casting, strain gauges are installed in the non-prestressed reinforcement and
8 tendons to monitor the local behavior of the specimens.

9 TEST RESULTS

10 Global behavior

11 *RC Specimens-* for RCSL, as previously mentioned, firstly, the lower jack protruded
12 out to simulate the middle column intact. Then, six steel assemblies with total weights of
13 5000 kg (11.0 klb) are hung below the beams symmetrically. Thus, the vertical reaction force
14 of -25 kN (-5.6 kip) is measured by the load cell #3 after the weights are hung completely. As
15 shown in **Fig. 4a**, the stage O'A' represents the phase of axial force releasing in the lower
16 jack. It can be seen that the frame structure is still within elastic range when point A' is
17 reached, which is corresponding to a vertical displacement of 34 mm (1.3 in.). Due to
18 bending moment reversal, the cracks in the beam end vicinity of the middle column (BEVM)
19 are formed in the lower part of the section. After that, additional load is applied gradually
20 from the upper jack until the specimen collapse. To facilitate the comparison of the
21 performance, the load-displacement curves are shifted from [0,-25 kN (-5.6 kip)] to origin (0,
22 0). Take Specimen RCSL as an example, the stage O'A' is shifted to OA. The load-
23 displacement relationship of remaining specimens shown in the figure is after shifting. The
24 critical values described below and listed in **Table 3** are also picked from the shifted curves.
25 From the shifted curve, when the vertical displacement reached 40 mm (1.6 in.), plastic

1 hinges are formed in the beam. Further increasing the vertical displacement, the load
2 resistance keeps increasing. This is attributed to compressive arch action developed in the
3 beams, as shown in **Fig. 5a**. When the beam ends have sufficient horizontal constraints, the
4 developed compressive struts could distribute partial of the vertical load to the side column
5 directly. The first peak load of the specimen is measured to 44 kN (9.9 kip) at a vertical
6 displacement of 67 mm (2.6 in.). The load resisting capacity began to decrease after this
7 loading stage and severe concrete crushing occurred in the compressive zone. The re-
8 ascending of the load-displacement curve is observed when the vertical displacement is
9 beyond 172 mm (6.8 in.). The re-ascending is attributed into catenary action developed in
10 beam longitudinal reinforcements (refer to **Fig. 6a**), although the concrete crushing and
11 flexural cracks are very severe in this stage. Even though rebar fracture subsequently
12 occurred in the beam ends, the load resistance continues increasing until the vertical
13 displacement reached 598 mm (23.5 in.). At this stage, the ultimate load capacity of 68 kN
14 (15.3 in.) is measured and the load resistance is suddenly dropped due to rebar fracture
15 occurred in both beam ends near to the side column (BENS). The failure mode of the
16 specimen is illustrated in **Fig. 7a**. As shown in the figure, rebar fracture is only occurred in
17 the BENS. The two-span beam is deformed as parabolic curve and thus, curved catenary
18 action is developed.

19 For Specimen RCLL, as it has much larger span/depth ratio, heavier steel weights of
20 6000 kg (13.2 klb) are designed. Thus, it results in larger initial axial force of -30 kN (6.7
21 kip) in the lower jack. As shown in the shifted curve, plastic hinges are formed in the beam
22 when the vertical load reached 25 kN (5.6 kip), which means that the yielding load of this
23 specimen is less than the initial axial force. If no other load resisting mechanisms could be
24 employed to resist the vertical load, the specimen would have collapsed during the phase of
25 axial force releasing. Fortunately, the first peak load of 36 kN (8.1 kip) is achieved in this

1 specimen due to compressive arch action developed in beams, which is greater than its initial
2 axial force (30 kN or 6.7 kip). After that, the load resistance begins to decrease due to
3 concrete crushing. When the vertical displacement reached 120 mm (4.7 in.), the
4 displacement suddenly increased to 273 mm (10.7 in.) caused by the compressive arch action
5 vanished, which result in the load resisting capacity less than the force transferred from the
6 hung steel weights. However, the collapse is prevented at a vertical displacement of 273 mm
7 (10.7 in.) due to the additional load resistance from the catenary action. Thus, the response of
8 this specimen demonstrated that the compressive arch action is the frontier of the defense
9 while the catenary action is the second one. The failure mode of this specimen is shown in
10 **Fig. 7b**. Similar to RCSL, rebar fracture is only observed in BENS and the beams are
11 deformed curved.

12 *PC Specimens*-for PCSL-0.6, it has BPT with designed and true effective prestress of
13 $0.6f_{pu}$ and $0.53f_{pu}$, respectively. Similar to RCSL, the initial axial force in the lower jack is
14 about -25 kN (-5.6 kip) after the weight of 5000 kg (11.0 klb) is fully hung. Different with
15 RCSL, no cracks are observed in the beams when the weights are applied. As shown in **Fig.**
16 **4b**, the yielding load of 42 kN (9.4 kip), which is 131% of RCSL, is obtained at a vertical
17 displacement of 41 mm (1.6 in.). At this stage, the flexural cracks at the BEVM are wider
18 than that at the BENS, which is quite different with that in RCSL. Additionally, as the load
19 resistance keeps increasing with further increase of the vertical displacement, the value of
20 first peak load is hard to mark. The discussion of the load resisting mechanism in following
21 section will reveal that less compressive arch action is developed in PC beams but the
22 stretching of the tendon will provide additional resistance. When the displacement reached
23 480 mm (18.9 in.), rebar fracture first occurred in the left BEVM. With the further increase of
24 the displacement to 560 mm (22.0 in.) and 621 mm (24.4 in.), rebar fractures are also
25 observed in the BENS. The ultimate load capacity in catenary action stage is measured to 127

1
2
3 1 kN (28.5 kip), which is 187% of that of RCSL. Thus, BPT could increase the ultimate load
4
5 2 capacity significantly. The test stopped at a vertical displacement of 679 mm (26.7 in.) due to
6
7 3 anchor slip occurred in the jacking end. The failure mode of this specimen is shown in **Fig. 8**.
8
9 4 Different to RCSL, the PC beams with BPT deformed straightly and the widest crack is
10
11 5 formed in the BEVM. Moreover, comparing to RCSL, the crack width in the BENS is much
12
13 6 thinner.
14
15

16
17 7 Similar to RCLL, PCLL-0.6 has span/depth ratio of 14 and thus, the initial axial force
18
19 8 is -30 kN (6.7 kip). The true effective prestress of the tendon is $0.55f_{pu}$ due to prestress loss.
20
21 9 The measured vertical displacement is 33 mm (1.3 in.) when the axial force fully released.
22
23 10 The yielding load of this specimen is 37 kN (8.5 kip), which is 148% of that of RCLL, at a
24
25 11 vertical displacement of 45 mm (1.8 in.). Thus, comparing to PCSL-0.6, BPT is more
26
27 12 effective for upgrading the yielding load of RCLL. Similar to PCSL-0.6, hard to mark first
28
29 13 peak load in the curve as the load-displacement curve also keeps increasing with increase of
30
31 14 the vertical displacement. Rebar fracture is firstly observed in the BEVM at a vertical
32
33 15 displacement of 452 mm (17.8 in.). When the vertical displacement reached 550 mm (21.7
34
35 16 in.), rebar fracture is also occurred in the left BENS. The failure mode of this specimen is
36
37 17 illustrated in **Fig. 9**. Similar to PCSL-0.6, the beams are deformed straightly. Different to
38
39 18 RCLL, more severe damage is occurred in the BEVM than that in BENS.
40
41
42
43

44
45 19 Comparing to PCSL-0.6, PCSH-0.6 has higher beam longitudinal reinforcement ratio
46
47 20 of 1.0%. The vertical displacement is 14 mm (0.6 in.) when the initial axial force in the lower
48
49 21 jack is released completely. The yielding load of 55 kN (12.3 kip) is achieved at a vertical
50
51 22 displacement of 43 mm (1.7 in.). Thus, comparing to PCSL-0.6, PCSH-0.6 achieved much
52
53 23 higher initial stiffness and yielding load. Similar to foregoing PC specimens, the load
54
55 24 resistance increases with further increasing the displacement, although concrete crushing and
56
57 25 wide cracks are accompanied. The load resistance first drops when the vertical displacement
58
59
60

1 reached 445 mm (17.5 in.) due to rebar fracture occurring in the right BEVM. Rebar fracture
2 is also observed in the left BENS at a displacement of 613 mm (24.1 in.). The measured
3 ultimate load capacity is 145 kN (32.6 kip), which is about 114% of that in PCSL-0.6.

4 Comparing to PCSL-0.6, PCSL-0.75 has larger designed effective prestress of $0.75f_{pu}$
5 and the true effective prestress of $0.71f_{pu}$. Comparing to other PC specimens, the camber of 3
6 mm (0.1 in.) in the middle-span of the beam is measured before applying the weights. The
7 vertical displacement is measured to be 19 mm (0.7 in.) after completely releasing of the
8 axial force in the lower jack. Moreover, the yielding load of 46 kN (10.3 kip) is measured at a
9 vertical displacement of 40 mm (1.6 in.). Thus, higher initial effective prestress will increase
10 the initial stiffness slightly. The rebar fracture is first occurred in the right BENM at a vertical
11 displacement of 361 mm (14.2 in.), which is much earlier than that in PCSL-0.6.
12 Subsequently, it occurred in the both BENS at the displacements of 490 mm (19.3 in.) and
13 524 mm (20.6 in.), respectively. The specimen is stopped at a vertical displacement of 575
14 mm (22.6 in.) due to anchor slipped occurred in the jacking point, similar to PCSL-0.6. The
15 failure mode of PCSH-0.6 and PCSL-0.75 are shown in **Figs. 10** and **11**, respectively.

16 **Horizontal reaction**

17 As shown in **Fig. 12**, for RCSL, considerable compressive force is measured at the lower
18 roller initially. It begins to decrease after vertical displacement reached 100.6 mm (4.0 in.)
19 due to concrete crushing. Tensile force is measured in the lower roller when the vertical
20 displacement reached 487.5 mm (19.2 in.). However, the upper roller consistently measured
21 tensile force during test. Thus, the total compressive force in relatively small displacement
22 stage is mainly attributed to the lower roller while the total tensile force in large displacement
23 stage is attributed to both rollers. However, for PCSL-0.6, much larger tensile force is
24 measured in the upper roller from the beginning of the test due to substantial tensile force
25 from BPT. Moreover, although compressive force is also measured in the lower roller, the

1 maximum compressive force is -65.6 kN (-14.7 kip), which is much less than that of RCSL.

2
3 If we look at the total reaction force, similar to previous RC tests³⁻¹¹, for RC specimens,
4 significant compressive reaction force is initially measured in the horizontal constraints. As
5 shown in **Fig. 13**, the maximum compressive reaction force of -136 kN (-30.6 kip) and -142
6 kN (-32.0 kip) are measured in RCSL and RCLL, respectively. The compressive reaction
7 force began to decrease when the displacement beyond 80 mm or 3.1 in. ($0.03l_n$) and 100 mm
8 or 3.9 in. ($0.03l_n$) for RCSL and RCLL, respectively. l_n represents the clear span of the single
9 beam. In accordance with their load resisting behavior, the decrease of the horizontal reaction
10 force related to the compressive arch action vanishing and concrete crushing. When the
11 vertical displacement beyond 220 mm (8.7 in.) [$0.08l_n$ for RCSL and $0.07l_n$ for RCLL],
12 tensile force is measured. The maximum horizontal tensile force in RCSL and RCLL are 153
13 kN (34.3 kip) and 135 kN (30.3 kip), respectively. However, different with RCSL and RCLL
14 and previously tested RC specimens³⁻¹¹, for PC Specimens PCSL-0.6, PCLL-0.6, PCSH-0.6,
15 and PCSL-0.75, no compressive reaction force is observed during the test, which further
16 confirmed less compressive arch action is developed in PC beams. As explained in **Fig. 5b**,
17 the post-tensioning tendon will aggravate the compressive stress at the BEVM but relieve the
18 compressive stress at the BENS. Thus, no effective compressive strut is able to develop in the
19 beams for load redistribution. However, the tensile reaction force remains constant when the
20 vertical displacement reached 70-80 mm (2.8-3.1 in.). The re-ascending of the tensile reaction
21 force is observed in PC specimens with short and long span at the displacements of 170 mm
22 (6.7 in.) and 190 mm (7.5 in.), respectively. With increasing the vertical displacement, the
23 horizontal tensile force keeps increasing. The maximum tensile reaction force measured in
24 PCSL-0.6, PCSH-0.6, PCSL-0.75, and PCLL-0.6 is 291 kN (65.4 kip), 321 kN (72.1 kip),
25 265 kN (59.6 kip), and 280 kN (62.9 kip), respectively. The lower reaction force measured in
26 PCSL-0.75 is due to anchor slipped occurred in the jacking end at the relatively early vertical

1 displacement of 575 mm (22.6 in.).

2 **Prestressing force in BPT**

3 **Fig. 14** presents the response of prestress force in the tendon versus the vertical displacement.

4 As shown in the figure, the initial prestress force deducting prestress loss is 97 kN (21.8 kip),
5 100 kN (22.5 kip), 130 kN (29.2 kip), and 101 kN (22.7 kip) in PCSL-0.6, PCSH-0.6, PCSL-
6 0.75, and PCLL-0.6, respectively. It is found that the prestress force increased slowly before
7 the vertical displacements reached 100 mm (3.9 in.) and 150 mm (5.9 in.) for PC specimen
8 with short and long span, respectively. Comparing the response of horizontal reaction force
9 with prestress force in PC specimens, it is hard to explain the increase of tensile reaction
10 force in the initial stage. It is suggested that since bonded tendon is used in this study, the
11 prestress force measured in the jacking end could not represent the variation of the prestress
12 force of the tendon in other places well. When the vertical displacements exceeds 100 mm
13 and 150 mm (5.9 in.) for PC specimen with short and long span respectively, the increase of
14 the prestress force is linear until yielding. Based on the test results, the maximum tensile
15 force in the tendon of PCSL-0.6, PCSH-0.6, PCSL-0.75, and PCLL-0.6 are 192 kN (43.1
16 kip), 186 kN (41.8 kip), 187 kN (42.0 kip), and 182 kN (40.9 kip), respectively. They are
17 related to prestress stress of $1.05 f_{pu}$, $1.02 f_{pu}$, $1.03 f_{pu}$, and $1.0 f_{pu}$, respectively.

18 **Deformation shape of beams**

19 **Fig. 15** gives the beam deformation shape of typical RC and PC specimen in accordance with
20 critical stages: the axial force just released, yield load, first peak load, 100 mm (3.9 in.),
21 200mm (7.9 in.), 300mm (11.8 in.), and ultimate load. As shown in **Fig. 15a**, for RCSL, the
22 deformation shape of beam is curved. In the ultimate load stage, the chord rotation, which is
23 defined as the ratio of displacement in the middle column to the clear span of the beam¹⁵, will
24 slightly over-estimate the rotation of the BESC but significantly under-estimate the rotation
25 in BEVM. This is quite different with that observed in previous tests^{2,4,5,6} as the initial service

1
2
3 1 load is well simulated in this study. For PCSL-0.6, as shown in **Fig. 15b**, the beam is
4
5 2 deformed straightly when the displacement is beyond 100 mm (3.9 in.) and severe flexural
6
7 3 cracks are formed in the BEVM. In the ultimate load stage, the chord rotation agrees the
8
9 4 deformation shape of the beam well, although it is originally defined for non-prestressed RC
10
11 5 specimen in existing design guideline¹⁵.

6 **Strain gauge reading**

7 **Figs. 16a** and **b** show the variation of strain results along beam top and bottom longitudinal
8
9 8 reinforcements of PCSL-0.6, respectively. As shown in the figures, similar to non-prestressed
10
11 9 RC specimens⁴, bending moment reversal is observed at the BEVM after releasing of the
12
13 10 initial axial force in the lower jack. Yielding is first occurred in the top reinforcement at the
14
15 11 BENS, rather than the bottom reinforcement at the BEVM, which is quite different to the
16
17 12 previous non-prestressed RC specimens⁴. Moreover, the compressive strain in the beam
18
19 13 longitudinal reinforcements begins to decrease when the vertical displacement is beyond 400
20
21 14 mm (15.7 in.). When the vertical displacement reached 600 mm (23.6 in.), the bottom
22
23 15 reinforcement is in tension across the whole span. **Fig. 16c** gives the results of strain gauges
24
25 16 attached on the post-tensioning tendons. Due to unknown reason, partial of the strain gauges
26
27 17 are faulty before tests. As shown in the figure, initially, all strain gauge read similar value
28
29 18 ranged from 4400 $\mu\epsilon$ to 4600 $\mu\epsilon$. When the vertical displacement increased, P2 and P3, which
30
31 19 are near to the side column, increased their strain dramatically with high slope. However, the
32
33 20 increase of remaining strain gauges is relatively very slow. It can be seen that P11 and P12,
34
35 21 which nearby the BEVM, suddenly increased abruptly when the vertical displacement is
36
37 22 beyond 400 mm (15.7 in.). Actually, as shown in **Fig. 6b**, the tendon at the BEVM will
38
39 23 become a straight line when the vertical displacement reached 400 mm (15.7 in.).

24 **ANALYTICAL ANALYSIS AND DISCUSSIONS**

1 Dynamic performance of tested specimens

2 The scenario of column missing caused by terrorist attacks is considered in this study.
 3 The most realistic setup should be designed by removal of the column suddenly. Although
 4 quasi-static pushdown test is most commonly used for evaluation of the performance of
 5 beam-column substructures mitigating progressive collapse, it is still necessary to assess the
 6 dynamic behavior of beam-column substructures. Capacity curve method, which is first
 7 proposed by Izzuddin *et al.*¹⁷, is frequently used to predict the dynamic capacity of the
 8 substructures based on the measured load-displacement curves (Tsai and Lin¹⁸, and Qian and
 9 Li¹⁹). The capacity curve method is mathematically expressed as:

$$10 \quad P_{CC}(u_d) = \frac{1}{u_d} \int_0^{u_d} P_{NS}(u) du \quad (3)$$

11 where $P_{CC}(u)$ and $P_{NS}(u)$ represent the capacity function and the nonlinear static loading
 12 estimated at the displacement demand u , respectively.

13 **Fig. 17** shows the dynamic behavior of test specimens. It is found that the dynamic
 14 ultimate capacity of RCSL, RCLL, PCSL-0.6, PCSL-0.75, PCSH-0.6, and PCLL-0.6 are 46.7
 15 kN (10.5 kip), 33.2 kN (7.5 kip), 88.0 kN (19.8 kip), 90.8 kN (20.4 kip), 103.8 kN (23.3 kip),
 16 and 69.2 kN (10.5 kip), respectively.

17 De-composite the resistance contribution of axial force and bending moment

18 For the process of releasing of axial force in the middle column, based on equilibrium and
 19 refer to **Fig. 18**, the bending moment (M_L^M), axial force (N_L^M), and shear force (V_L^M) at
 20 Section A-A are determined as:

$$21 \quad M_L^M = V_L L_L - H_i^L (\delta + 0.35) - H_b^L (\delta - 0.35) - G_7 \times 2.0625 - G_6 \times 1.375 - G_5 \times 0.6875 - \frac{1}{2} q \times L^2 \quad (4)$$

$$22 \quad N_L^M = [(V_L - G_7 - G_6 - G_5) \tan \theta_L^M + H_L] \cos \theta_L^M \quad (5)$$

$$23 \quad V_L^M = [(V_L - G_7 - G_6 - G_5) - N_L^M \sin \theta_L^M] / \cos \theta_L^M \quad (6)$$

where V_L is the vertical reaction force measured by load cell #5 in **Fig. 3b**; H_t^L and H_b^L are the horizontal reaction force from upper and lower roller, respectively; $G_1 \sim G_7$ are the gravitational load of single weight assembly (8.2 kN and 1.8 kip); q is assumed to be 0.001 kN/mm (0.006 kip/in.) for consideration of the self-weights of the beam; $\theta_L^M = \arctan\left(\frac{D_4 - D_5}{0.6875}\right)$ is based on chord rotation of the segment.

Similarly, the bending moment (M_R^M), axial force (N_R^M), and shear force (V_R^M) in the symmetric section of right beam is determined as:

$$M_R^M = V_R L_R - H_t^R (\delta + 0.35) - H_b^R (\delta - 0.35) - G_1 \times 2.0625 - G_2 \times 1.375 - G_3 \times 0.6875 - \frac{1}{2} q \times L^2 \quad (7)$$

$$N_R^M = [(V_R - G_1 - G_2 - G_3) \tan \theta_R^M + H_R] \cos \theta_R^M \quad (8)$$

$$V_R^M = [(V_R - G_1 - G_2 - G_3) - N_R^M \sin \theta_R^M] / \cos \theta_R^M \quad (9)$$

where V_R is the vertical reaction force measured by load cell #4 in **Fig. 3b**; H_t^R and H_b^R respectively are assumed equal to H_t^L and H_b^L , as no load cells are installed for measuring;

$\theta_R^M = \arctan\left(\frac{D_4 - D_3}{0.6875}\right)$ is based on chord rotation of the segment.

After that, based on the vertical force equilibrium at the middle joint, it is determined that:

$$P = (N_L^M \sin \theta_L^M + V_L^M \cos \theta_L^M) + (N_R^M \sin \theta_R^M + V_R^M \cos \theta_R^M) \quad (10)$$

After re-arrangement, it becomes:

$$\begin{aligned} P &= (N_L^M \sin \theta_L^M + N_R^M \sin \theta_R^M) + (V_L^M \cos \theta_L^M + V_R^M \cos \theta_R^M) \\ &= \sum_r^{L,R} N_r^M \sin \theta_r^M + \sum_r^{L,R} V_r^M \cos \theta_r^M \end{aligned} \quad (11)$$

where $\sum_r^{L,R} N_r^M \sin \theta_r^M$ and $\sum_r^{L,R} V_r^M \cos \theta_r^M$ represent the resistance contribution from axial force and shear force, respectively. As the shear force could be determined by the bending moment acting on the beams, $\sum_r^{L,R} V_r^M \cos \theta_r^M$ can also be taken as the contribution from the

1 bending moment. For the process of applying extra axial force on the middle column, the sign
2 of the applied load and shear force will reverse. However, the equations for determination of
3 the internal force are identical. For the sake of brevity, RCSL, PCSL-0.6, and PCSH-0.6 are
4 selected to show the decomposition of vertical resistance.

5 As shown in **Fig. 19a**, the contribution of shear force begins to decrease after crushing
6 occurred in the beam sections. The re-ascending of the load resisting capacity in catenary
7 action stage is mainly due to the contribution of axial force changing from compression to
8 tension. However, as observed in the figure, before fracture of beam longitudinal
9 reinforcements, shear force (or flexural bending moment) could also provide considerable
10 contribution in the stage of catenary action. Therefore, it is unrealistic to assume the load
11 resisting capacity of the substructures in catenary action stage purely attributed into the
12 tension of beam longitudinal reinforcements, which is commonly accepted by previous
13 studies²⁰.

14 As shown in **Fig. 19b**, for PCSL-0.6, the varying of the contribution of shear force is
15 similar to RCSL. However, the contribution of axial force is quite different as the strands
16 could provide considerable tension at the beginning of the test. If we further de-composite the
17 axial force contribution, it is found that compression actually is also observed at the axial
18 force component from RC beam. Moreover, the maximum compression force of 7.5 kN (1.7
19 kip) is measured in the axial force component from RC beam, which is similar to RCSL. As
20 similar results are observed in PCSH-0.6, no further discussion is given for it.

21 **Effects of span/depth ratio**

22 As shown in **Fig. 4** and **Table 3**, comparing with RCLL, RCSL achieved greater yielding,
23 first peak, and ultimate load by 28%, 22%, and 51%, respectively. However, for PC
24 specimens, the yielding and ultimate load capacity of PCSL-0.6 is about 114% and 122% of
25 that of PCLL-0.6. Thus, the span/depth ratio has greater effects for RC specimens than PC

specimens, especially for ultimate load capacity in catenary action stage. As shown in **Figs. 7, 8, and 9**, for both RC and PC specimens, the span/depth ratio has little effects on their failure modes (widest flexural cracks are occurred at the beam end nearby the columns) as the span/depth ratio is 12 and 14 for specimens with short and long design span, respectively. Both span/depth ratios are large enough for flexural dominated failure in beams. Another reason is the prototype frames are seismic designed and detailed, which have high transverse reinforcement ratio in the beam ends nearby the columns and prevented the possible shear failure at the beam end due to smaller span/depth ratio.

Effects of the amount of non-prestressed reinforcements

Comparison of the behavior of PCSL-0.6 and PCSH-0.6, it is found that higher non-prestress reinforcement ratio (1.0%) could increase the yielding load and ultimate load capacity by 31% and 14%, respectively. As listed in **Table 3**, the initial stiffness of PCSL-0.6 and PCSH-0.6 are 0.93 kN/mm (5.3 kip/in.) and 1.23 kN/mm (7.0 kip/in.), respectively. Thus, PCSH-0.6 increased the initial stiffness by 32%. As shown in **Figs. 8 and 10**, the amount of non-prestressed reinforcement ratio has little effects on the failure mode and load resisting mechanism of PC frames to resist progressive collapse. This could be explained as the non-prestressed reinforcement ratio is 0.7% or 1.0% for PC specimens with light or heavy non-prestressed reinforcement, respectively. Similar as above explanation, the relatively heavy transverse reinforcement ratio installed in the beam end nearby the column prevents the possible shear failure even relatively heavy non-prestressed reinforcement ratio is designed.

Effects of the initial effective prestress

Comparing to PCSL-0.6, PCSL-0.75 achieved 10% increase of yielding load. However, PCSL-0.75 exhibited lower ultimate load capacity. This is due to anchor slip occurred in the jacking end at the displacement of 575 mm (22.6 in.), which prevent the tendon to further develop catenary action. As shown in **Figs. 8 and 11**, initial effective prestress has little

1 effects on the failure mode of the specimen.

2 **Effects of the bonded post-tensioning tendons**

3 By comparing the behavior of PCSL-0.6 with RCSL, it is found that BPT could increase the
4 yielding and ultimate load capacity by 31% and 87%, respectively. For PCLL-0.6, the BPT
5 increased the yielding and ultimate load capacity of RCLL by 48% and 131%, respectively.
6 Thus, BPT has greater impacts on behavior of specimens with larger span/depth ratio. As
7 shown in **Fig. 13**, considerable compressive reaction force is developed in RC beams in the
8 compressive arch action stage, but not PC specimens. This is because little compressive arch
9 action can be developed in PC beams to resist progressive collapse. Comparing the failure
10 mode of PC specimens with corresponding RC specimens, it is found that the BPT will
11 aggravate the damage in the BEVM and relief the damage in the BENS. In PC specimens,
12 rebar fracture is first observed in the BEVM while no rebar fracture is observed in RC
13 specimens, as shown in **Figs. 7, 8, and 9**. As shown in **Fig. 6**, straight catenary action and
14 curved catenary action are developed in PC and RC specimens, respectively. **Fig. 20**
15 illustrates the comparison of the load-displacement curves from PC specimens with bonded
16 strands and counterparts with unbonded strands (PCUSL-0.6 and PCUSH-0.6). The results of
17 PCUSL-0.6 and PCUSH-0.6 had been discussed in authors' previous paper¹². As shown in
18 **Fig. 20**, PCUSL-0.6 and PCUSH-0.6 achieve relatively less initial stiffness and yield load
19 comparing to PCSL-0.6 and PCSH-0.6, respectively. However, in catenary actions stage, the
20 ultimate load capacity of PCUSL-0.6 and PCUSH-0.6 are 140 kN (31.5 kip) and 170 kN
21 (38.2 kip), respectively. Thus, PC specimens with unbonded strands are able to mobilize
22 larger catenary action as the stress in unbonded strands are more uniform, which prevents
23 premature fracture of the strands in catenary action stage. Due to spacing limiting, the effects
24 on bonding of strands on horizontal reaction force and failure modes are not discussed herein.

1 CONCLUSIONS

2 Based on the results of this experimental investigation, the following conclusions are drawn:

- 3 1. Different to conventional RC frames, post-tensioning concrete (PC) frames has little
4 benefits from compressive arch action to prevent progressive collapse. However, the
5 stretching of bonded post-tensioning tendons (BPT) could provide additional vertical
6 load resistance from the beginning of the test. However, the BPT will not detriment
7 the deformation capacity of the frames and thus, the catenary action attributed to both
8 non-prestressed reinforcements and BPT, which could provide reliable second defense
9 line for progressive collapse prevention. BPT could increase the yield load and
10 ultimate capacity of corresponding RC counterpart up by 48% and 131%,
11 respectively.
- 12 2. Test results indicated that higher initial effective prestress in the BPT will increase the
13 yield load capacity of the PC frame slightly, but not the ultimate load capacity.
14 Analytical analysis and test results revealed that the ultimate load capacity of the PC
15 frame is dependent on the amount of BPT and non-prestressed reinforcement ratio,
16 rather than the initial effective prestress in the BPT. Inversely, the potential of earlier
17 fracture of BPT raised by high initial effective prestress in the tendon should be taken
18 enough attentions.
- 19 3. Based on the test results, it is found that the RCLL with larger span/depth ratio of 14
20 will reduce the yield load and ultimate load capacity by 22% and 34%, respectively.
21 However, PCLL-0.6 with larger span/depth ratio 14 only decreases the yield load and
22 ultimate load capacity of PC frames only by 12% and 18%, respectively. Thus, the
23 span/depth ratio has less effect on PC frames than RC frames.
- 24 4. The amount of non-prestressed reinforcement could improve the capacity of PC
25 frames to resist progressive collapse, including yielding and ultimate load capacities.

1
2
3 1 Further studies should be conducted to capture the optimal ratio of prestressed
4
5 2 reinforcement to non-prestressed reinforcements for optimal resilience performance.
6
7

8 3 **FUTURE RESEARCH**

9
10 4 As the loss of column is instantaneous due to blast or vehicular impact, further research
11
12 5 studies are needed on dynamic performance of prestressed concrete frames subjected to
13
14 6 sudden column removal scenario. Moreover, more studies should be carried out by including
15
16 7 the impact effects of disaster such as fire and blast impact or pressure.
17
18

19 8 **ACKNOWLEDGMENTS**

20
21 9 This research was supported by a research grant provided by the Natural Science Foundation
22
23 10 of China (Nos.51778153, 51568004, 51478118). Any opinions, findings and conclusions
24
25 11 expressed in this paper do not necessarily reflect the view of Natural Science Foundation of
26
27 12 China.
28
29

30 13 **REFERENCES**

- 31
32
33 14 1. ASCE/SEI 7, "Minimum Design Loads for Buildings and Other Structures," Structural
34
35 15 Engineering Institute-American Society of Civil Engineers, Reston, VA, 2010, 424 pp.
36
37 16 2. Su, Y. P., Tian, Y., and Song, X. S., "Progressive Collapse Resistance of Axially-Restrained
38
39 17 Frame Beams," *ACI Structural Journal*, V. 106, No. 5, July-Aug. 2009, pp. 600-607.
40
41 18 3. Orton, S., Jirsa, J. O., and Bayrak, O., "Carbon Fiber-Reinforced Polymer for Continuing
42
43 19 in Existing Reinforced Concrete Buildings Vulnerable to Collapse," *ACI Structural Journal*,
44
45 20 V. 106, No. 5, July-Aug. 2009, pp. 608-616.
46
47 21 4. Yu, J., and Tan, K. H., "Experimental and Numerical Investigation on Progressive Collapse
48
49 22 Resistance of Reinforced Concrete Beam Column Sub-assemblages," *Engineering Structures*,
50
51 23 V.55, 2013, pp. 90-106.
52
53 24 5. Sasani, M., and Kropelnicki, J., "Progressive Collapse Analysis of an RC Structure," *The*
54
55 25 *Structural Design of Tall and Special Buildings*, V. 17, No. 4, 2008, pp.757-771.
56
57
58
59
60

- 1
2
3 1 6. Lew, H. S., Bao, Y. H., Pujol, S., and Sozen, M. A., "Experimental Study of Reinforced
4
5 2 Concrete Assemblies under Column Removal Scenario," *ACI Structural Journal*, V.111,
6
7 3 No.4, 2014, pp. 881-892.
- 8
9
10 4 7. Qian, K. and Li, B., "Slab Effects on the Response of Reinforced Concrete Substructures
11
12 5 after Loss of Corner Column." *ACI Structural Journal*, V.109, No. 6, 2012, pp. 845-855.
- 13
14 6 8. Dat, P. X., and Tan, K. H., "Experimental Study of Beam-Slab Substructures subjected to a
15
16 7 Penultimate-Internal Column Loss," *Engineering Structures*, V.55, 2013, pp. 2-15.
- 17
18 8 9. Ren, P. Q., Li, Y., Lu, X. Z., Guan, H., and Zhou, Y. L., "Experimental Investigation of
19
20 9 Progressive Collapse Resistance of One-Way Reinforced Concrete Beam-Slab Substructures
21
22 10 under a Middle-Column-Removal Scenario," *Engineering Structures*, V.118, July 2016, pp.
23
24 11 28–40.
- 25
26 12 10. Qian, K., Li, B., and Zhang, Z., "Influence of Multicolumn Removal on the Behavior of
27
28 13 RC Floors," *Journal of Structural Engineering*, V. 142, No. 5, May 2016, 04016006.
- 29
30 14 11. Peng, Z. H., Orton, S. L., Liu, J. R., and Tian, Y., "Experimental Study of Dynamic
31
32 15 Progressive Collapse in Flat-Plate Buildings subjected to Exterior Column Removal,"
33
34 16 *Journal of Structural Engineering*, V. 143, No. 9, Sep. 2017, 04017125.
- 35
36 17 12. Qian, K., Yi, Liu, Tao, Y., and Li, B., "Progressive Collapse Resistance of Post-Tensioned
37
38 18 Concrete Beam-Column Sub-assemblages with Un-Bonded Post-Tensioning Strands,"
39
40 19 *Journal of Structural Engineering*, V.144, No. 1, Jan.-2018, 04017182.
- 41
42 20 13. Kim, J., and Choi, H., "Monotonic Loading Tests of RC Beam-Column Subassemblage
43
44 21 Strengthened to Prevent Progressive Collapse," *International Journal of Concrete Structures*
45
46 22 *and Materials*, V.9, No.4, 2015, pp. 401-413.
- 47
48 23 14. GSA, "Progressive Collapse Analysis and Design Guidelines for New Federal Office
49
50 24 Buildings and Major Modernization Projects," *U.S. General Service Administration*,
51
52 25 Washington, DC, 2010.
- 53
54
55
56
57
58
59
60

- 1
2
3 1 15. DoD, "Design of Building to Resist Progressive Collapse," Unified Facility Criteria, UFC
4 4-023-03, *U.S. Department of Defense*, Washington, DC, 2005.
5
6 2
7
8 3 16. ACI Committee 318, "Building Code Requirements for Structural Concrete (ACI 318-14)
9 and Commentary (318R-14)," American Concrete Institute, Farmington Hills, MI, 2014, 433
10 pp.
11
12 4
13 5
14 6 17. Izzuddin, B. A., Vlassis, A. G., Elghazouli, A. Y., and Nethercot, D. A., "Progressive
15 Collapse of Multi-Storey Buildings due to Sudden Column Loss—Part I: Simplified
16 Assessment Framework," *Engineering Structures*, V. 30, No. 5, 2008, pp. 1308-18.
17
18 7
19 8 18. Tsai, M. H. and Lin, B. H., "Investigation of Progressive Collapse Resistance and
20 Inelastic Response for an Earthquake-Resistant RC Building Subjected to Column Failure."
21 *Engineering Structures*, V. 30, 2008, pp. 3619–3628.
22
23 9
24 10 19. Qian, K., and Li, B., "Research Advances in Design of Structures to Resist Progressive
25 Collapse." *Journal of Performance of Constructed Facilities*, ASCE, 29(5), 2015, B4014007.
26
27 11
28 12 20. Yi, W., He, Q., Xiao, Y., and Kunnath, S. K. "Experimental Study on Progressive
29 Collapse-Resistant Behavior of Reinforced Concrete Frame Structures." *ACI Structural
30 Journal*, 105(4), 2008, pp. 433-439.
31
32
33
34
35
36
37
38
39
40
41
42
43
44
45
46
47
48
49
50
51
52
53
54
55
56
57
58
59
60

1
2
3 **1 TABLES AND FIGURES**
4

5 **2 List of Tables:**
6

7 **3 Table 1** – Specimen properties
8

9 **4 Table 2** - Material properties of reinforcement and unbonded post-tensioning strands
10

11 **5 Table 3** – Test results
12
13
14
15
16

17 **7 List of Figures:**
18

19 **8 Fig. 1** –Bending moment of the PC sub-frame: (a) before removal of the middle column; and
20
21 (b) after removal of the middle column
22

23 **10 Fig. 2** –Dimensions and reinforcement details: (a) Specimen PCSL-06; (b) cross sections; and
24
25 (c) Specimen PCLL-0.6
26
27

28 **12 Fig. 3** – Test setup and instrumentation layout of the tests: (a) Setup; (b) Instrumentation
29
30 layout
31

32 **14 Fig. 4** – Load-displacement history: (a) RC specimens; (b) PC specimens
33

34 **15 Fig. 5** – Schematic of the compressive arch action: (a) RC specimen; (b) PC specimen
35

36 **16 Fig. 6** – Schematic of the catenary action: (a) RC specimen; (b) PC specimen
37

38 **17 Fig. 7** – Failure mode of controlled RC specimens: (a) RCSL; (b) RCLL
39

40 **18 Fig. 8** – Failure mode of PC specimen PCSL-0.6
41

42 **19 Fig. 9** – Failure mode of PC specimen PCLL-0.6
43

44 **20 Fig. 10** – Failure mode of PC specimen PCSH-0.6
45

46 **21 Fig. 11** – Failure mode of PC specimen PCSL-0.75
47

48 **22 Fig. 12** – Horizontal reaction force of lower and upper roller
49

50 **23 Fig. 13** – Comparison of the horizontal reaction force-displacement history
51

52 **24 Fig. 14** – Prestressed force in the tendon of all specimens
53

54 **25 Fig. 15** – Deformation shape of test specimens: (a) RCSL; (b) PCSL-0.6
55
56
57
58
59
60

1 **Fig. 16** – Strain gauge results of PCSL-0.6: (a) top non-prestressed rebar; (b) bottom non-
 2 prestressed rebar; (c) prestressed tendon

3 **Fig. 17** – Dynamic performance of the specimens

4 **Fig. 18** – The relationship of internal forces and the load resistance

5 **Fig. 19** – Resistance contributions from axial and shear force (a) RCSL, (b) PCSL-0.6, (c)
 6 PCSH-0.6

7 **Fig. 20** – Bonding effects on load-displacement curves

8
 9
 10
 11
 12
 13
 14
 15
 16
 17
 18
 19
 20
 21
 22
 23
 24
 25
 26
 27
 28
 29
Table 1-Specimen properties

Test ID	Beam Clear Span mm (in.)	Diameter of Post-tensioning Strands mm (in.)	Effective Prestress	Effective Prestress after Loss	Top (Bottom) Beam Long. Rebar Ratio ρ	Axial Force in the Center Column kN (kip)
RCSL	2750 (108.3)	N/A	N/A	N/A	0.7% (0.7%)	-25 (-5.6)
RCLL	3300 (129.9)	N/A	N/A	N/A	0.7% (0.7%)	-30 (-6.7)
PCSL-0.6	2750 (108.3)	12.7 (0.5)	$0.6 f_{pu}$	$0.53 f_{pu}$	0.7% (0.7%)	-25 (-5.6)
PCSL-0.75	2750 (108.3)	12.7 (0.5)	$0.75 f_{pu}$	$0.71 f_{pu}$	0.7% (0.7%)	-25 (-5.6)
PCSH-0.6	2750 (108.3)	12.7 (0.5)	$0.6 f_{pu}$	$0.54 f_{pu}$	1.0% (1.0%)	-25 (-5.6)
PCLL-0.6	3300 (129.9)	12.7 (0.5)	$0.6 f_{pu}$	$0.55 f_{pu}$	0.7% (0.7%)	-30 (-6.7)

16 Note: reinforcement ratio were determined using equation $\rho = A_s/bd_0$, in which b and d_0 represent the width and
 17 the effective depth of beam cross sections; f_{pu} is the ultimate strength of the strands.
 18
 19
 20
 21
 22

Table 2-Material properties of reinforcement and unbonded post-tensioning strands

Items		Nominal Diameter mm (in.)	Yield Strength MPa (ksi)	Ultimate Strength MPa (ksi)	Elongation (%)
Transverse Reinforcement	R6	6 (0.24)	372 (54)	510 (74)	19.5
Longitudinal Reinforcements	T10	10 (0.39)	455 (66)	635 (92)	22.8
Post-tensioning Strands		12.7 (0.5)	1650 (239)	1860 (270)	6.1

Notes: R6 represents plain bar of with diameter of 6 mm (0.24 in.); T10 represents deformed rebar with diameter of 10 mm (0.39 in.), respectively.

Table 3-Test results

Specimen ID	Critical Displacements, mm (in.)				Critical Loads, kN (kip)	Critical Loads, kN			MHTF kN (kip)	MPF kN (kip)
	RAF	YL	FPL	UL		YL	FPL	UL		
RCSL	34 (1.3)	40 (1.6)	67 (2.6)	598 (23.5)	32 (7.2)	44 (9.9)	68 (15.3)	153 (34.3)	N/A	
RCLL	59 (2.3)	46 (1.8)	80 (3.1)	413 (16.3)	25 (5.6)	36 (8.1)	45 (10.1)	135 (30.3)	N/A	
PCSL-0.6	20 (0.8)	41 (1.6)	N/A	621 (24.4)	42 (9.4)	N/A	127 (28.5)	291 (65.4)	192 (43.1)	
PCSH-0.6	14 (0.6)	43 (1.7)	N/A	613 (24.1)	55 (12.3)	N/A	145 (32.6)	321 (72.1)	186 (41.8)	
PCSL-0.75	19 (0.7)	40 (1.6)	N/A	575 (22.6)	46 (10.3)	N/A	117 (26.3)	265 (59.6)	187 (42.0)	
PCLL-0.6	33 (1.3)	45 (1.9)	N/A	625 (24.6)	37 (8.5)	N/A	104 (23.4)	280 (62.9)	182 (40.9)	

Note: RAF represents releasing axial force completely; YL means yielding load capacity; FPL represents first peak load; UL represents ultimate load capacity; MHTF means maximum horizontal tensile force; and MPF represents maximum prestressing force.

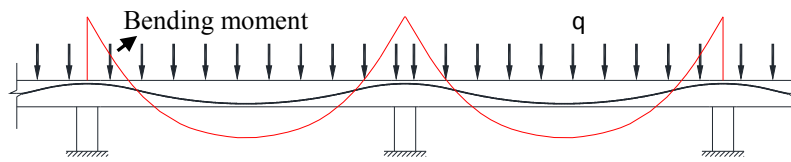

(a)

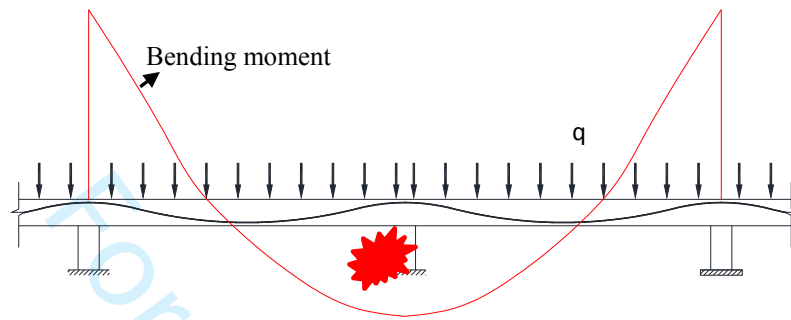

(b)

Fig. 1–Bending moment of the PC sub-frame: (a) before removal of the middle column; and (b) after removal of the middle column

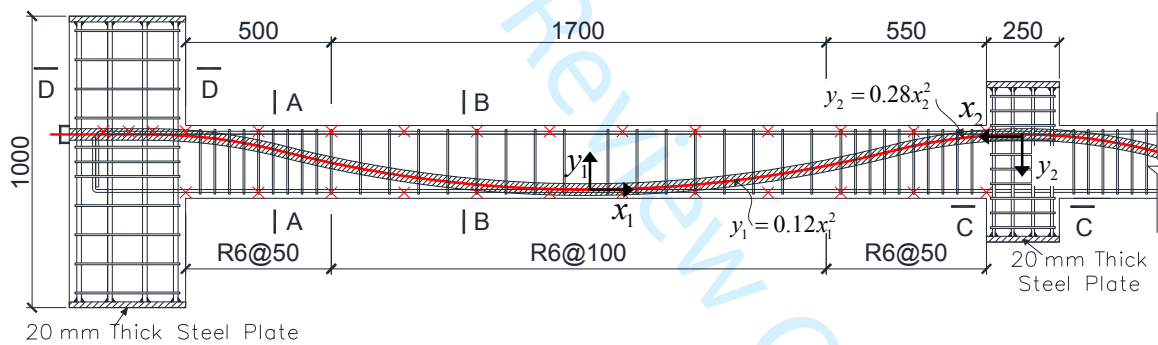

(a)

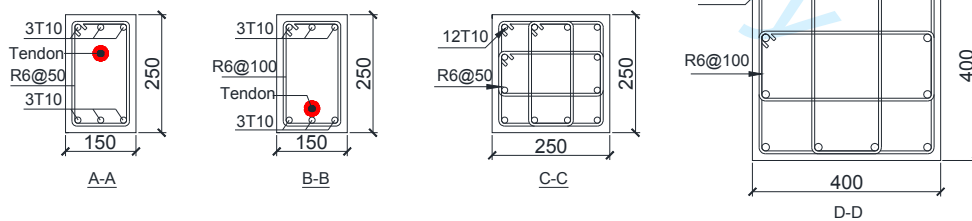

(b)

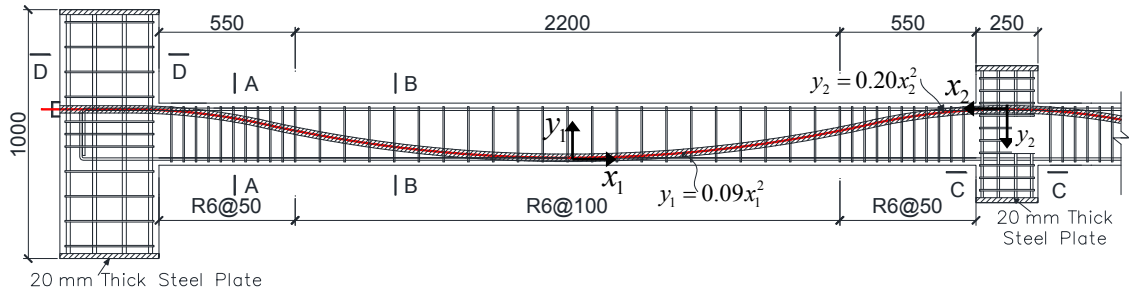

(c)

Fig. 2—Dimensions and reinforcement details: (a) Specimen PCSL-06; (b) cross sections; and (c) Specimen PCLL-0.6

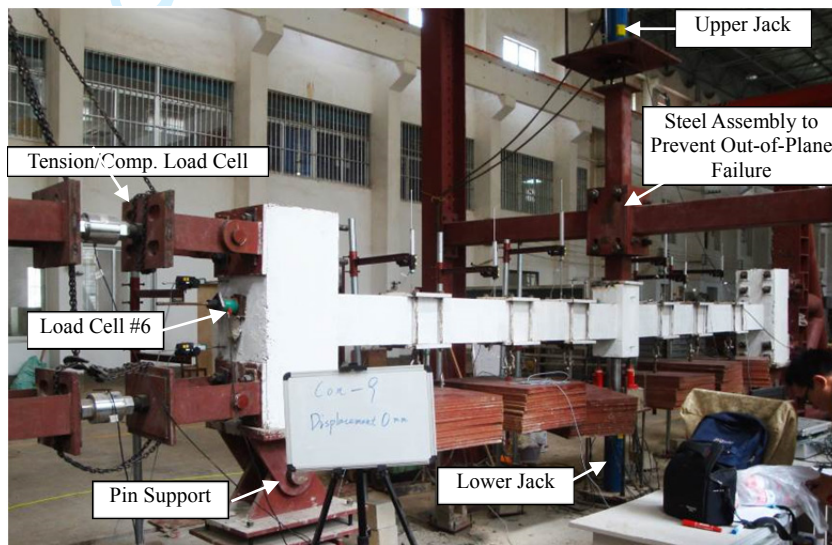

(a)

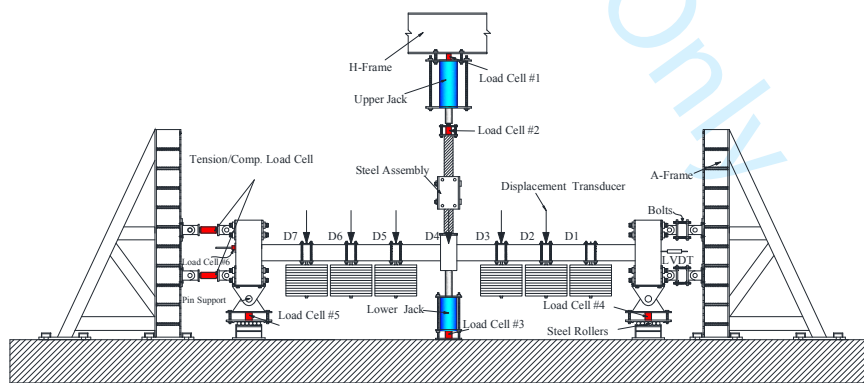

(b)

Fig. 3— Test setup and instrumentation layout of the tests: (a) Setup; (b) Instrumentation layout

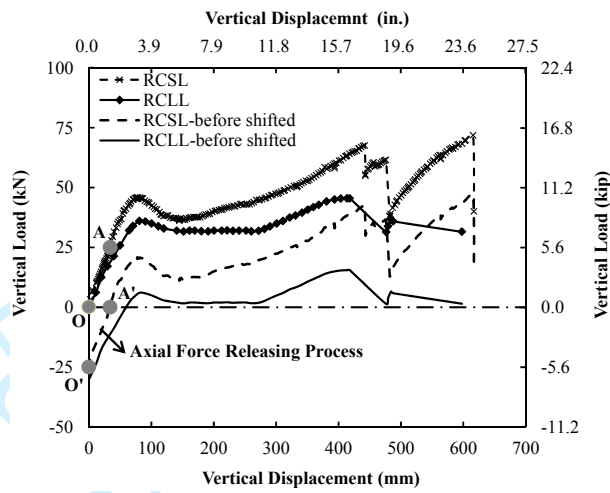

(a)

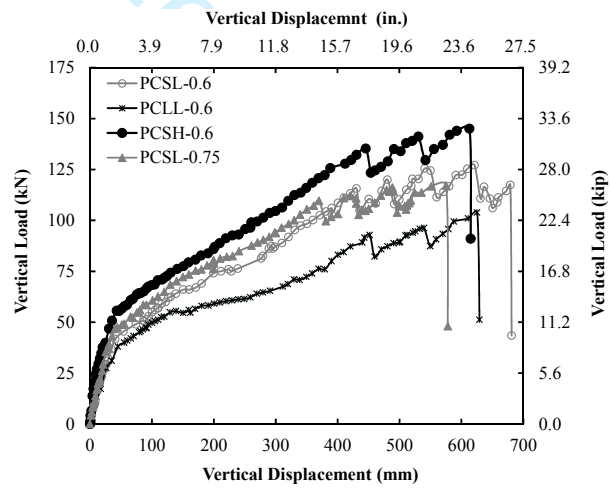

(b)

Fig. 4– Load-displacement history: (a) RC specimens; (b) PC specimens

1
2
3
4
5
6
7
8
9
10
11
12
13
14
15
16
17
18
19
20
21
22
23
24
25
26
27
28
29
30
31
32
33
34
35
36
37
38
39
40
41
42
43
44
45
46
47
48
49
50
51
52
53
54
55
56
57
58
59
60

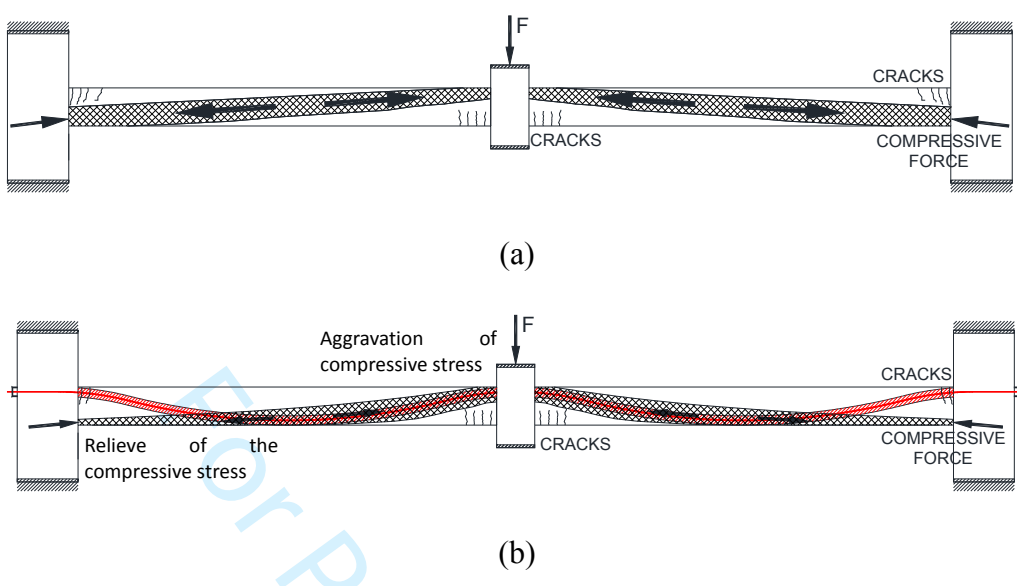

Fig. 5– Schematic of the compressive arch action: (a) RC specimen; (b) PC specimen

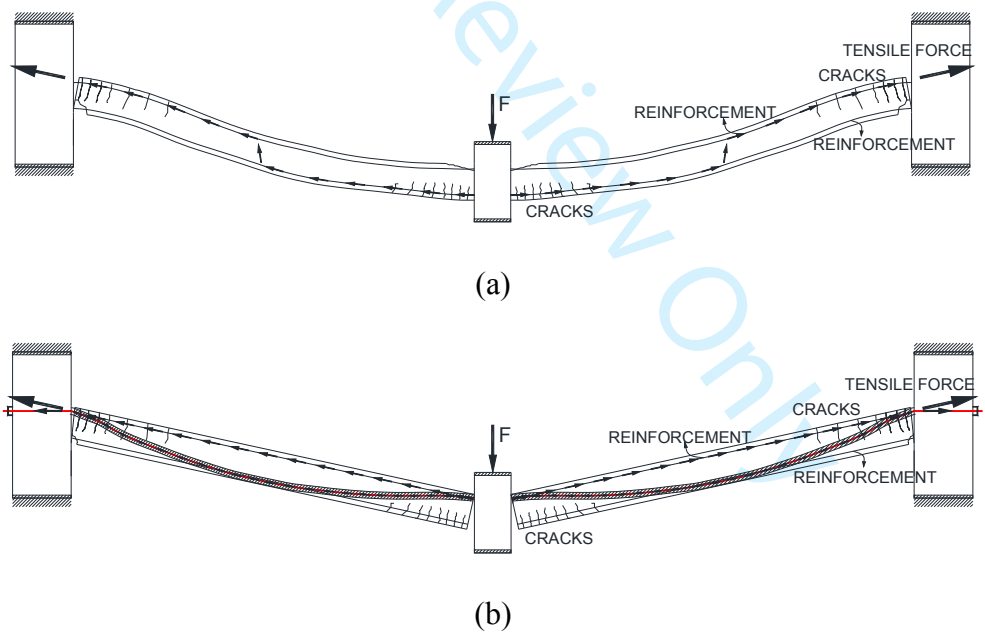
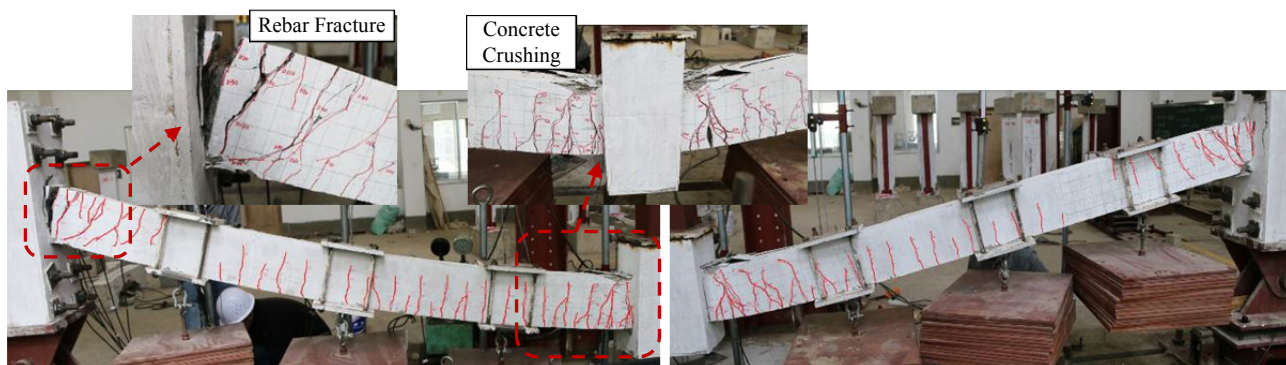
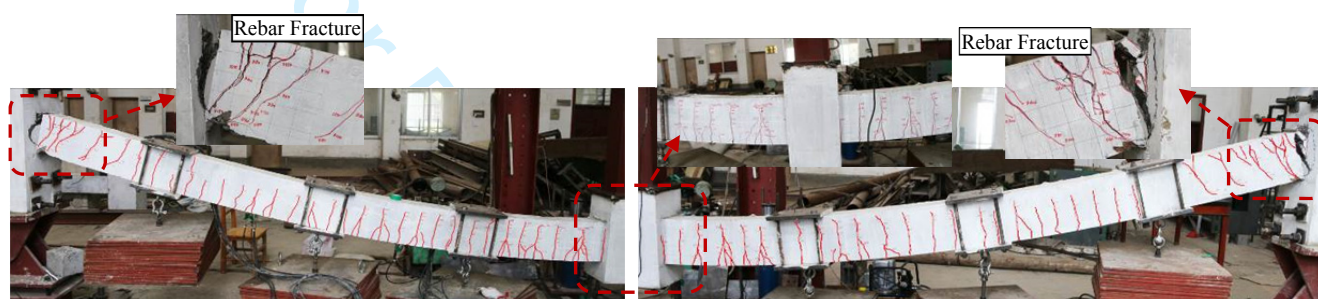

Fig. 6– Schematic of the catenary action: (a) RC specimen; (b) PC specimen



(a)



(b)

Fig. 7– Failure mode of controlled RC specimens: (a) RCSL; (b) RCLL

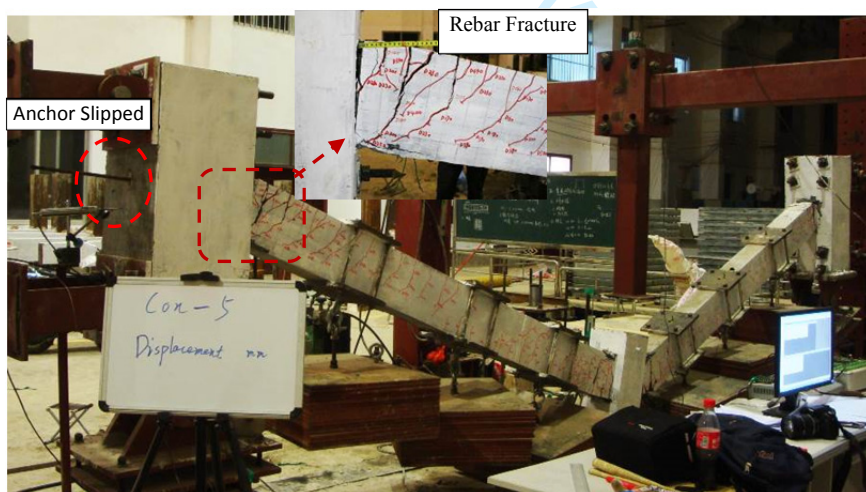

Fig. 8– Failure mode of PC specimen PCSL-0.6

1
2
3
4
5
6
7
8
9
10
11
12
13
14
15
16
17
18
19
20
21
22
23
24
25
26
27
28
29
30
31
32
33
34
35
36
37
38
39
40
41
42
43
44
45
46
47
48
49
50
51
52
53
54
55
56
57
58
59
60

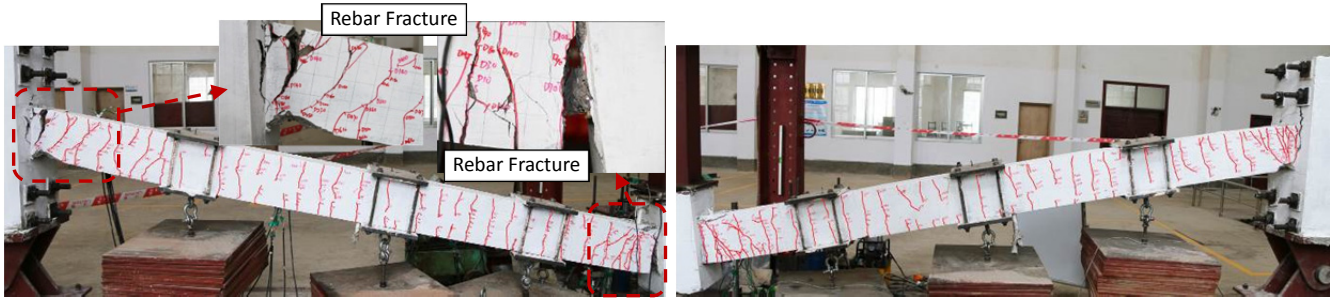

Fig. 9– Failure mode of PC specimen PCLL-0.6

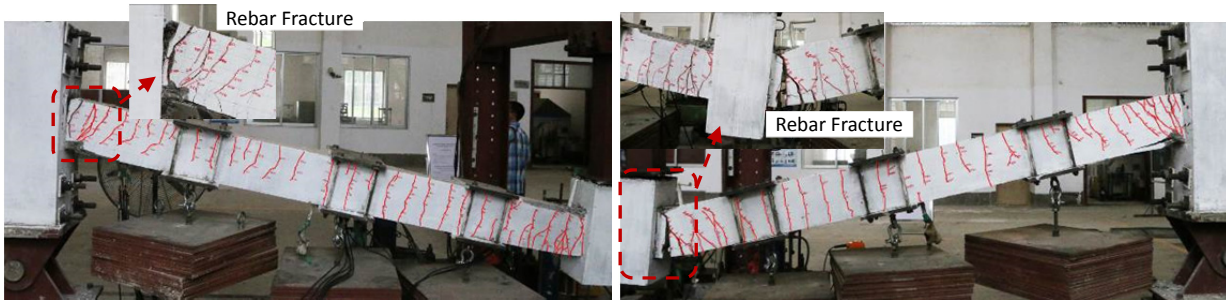

Fig. 10– Failure mode of PC specimen PCSH-0.6

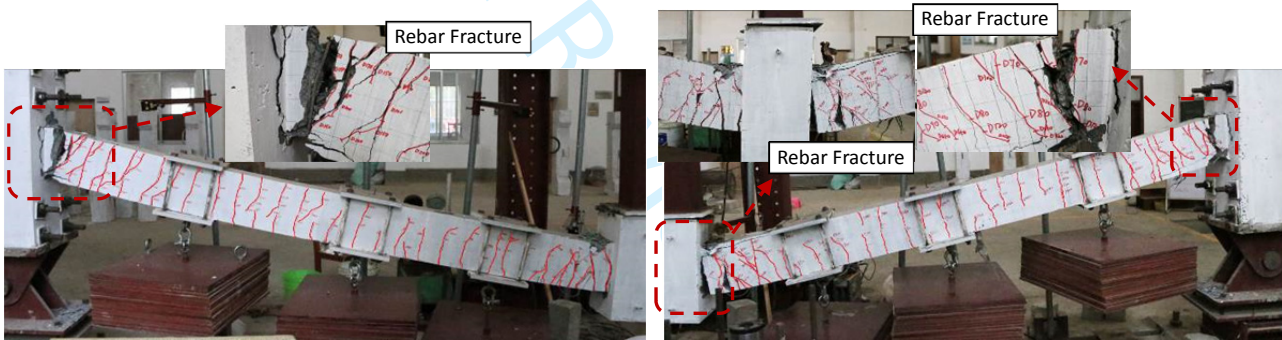

Fig. 11– Failure mode of PC specimen PCSL-0.75

1
2
3
4
5
6
7
8
9
10
11
12
13
14
15
16
17
18
19
20
21
22
23
24
25
26
27
28
29
30
31
32
33
34
35
36
37
38
39
40
41
42
43
44
45
46
47
48
49
50
51
52
53
54
55
56
57
58
59
60

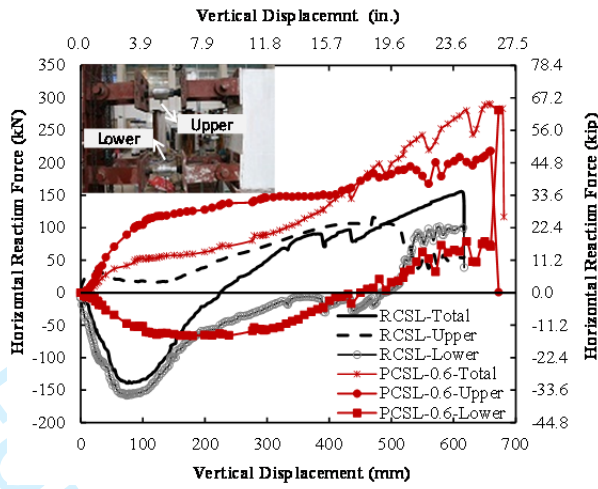

Fig. 12–Horizontal reaction force of lower and upper roller

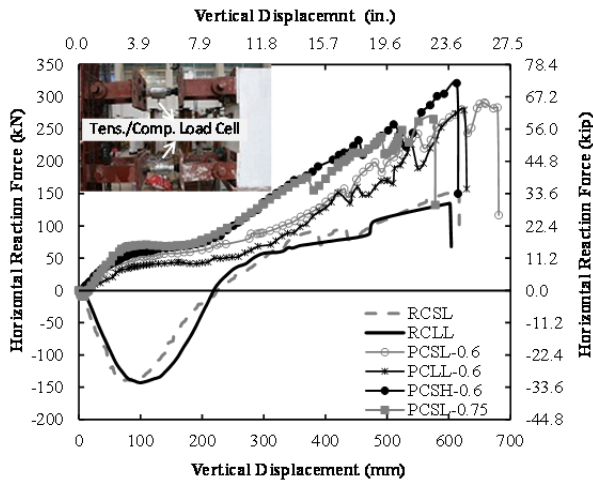

Fig. 13– Comparison of the horizontal reaction force-displacement history

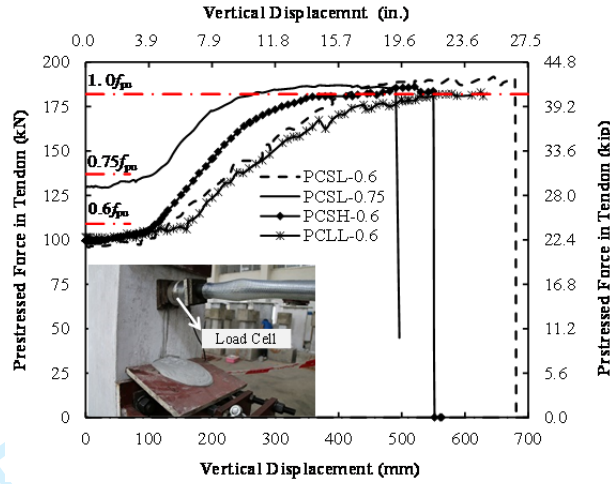
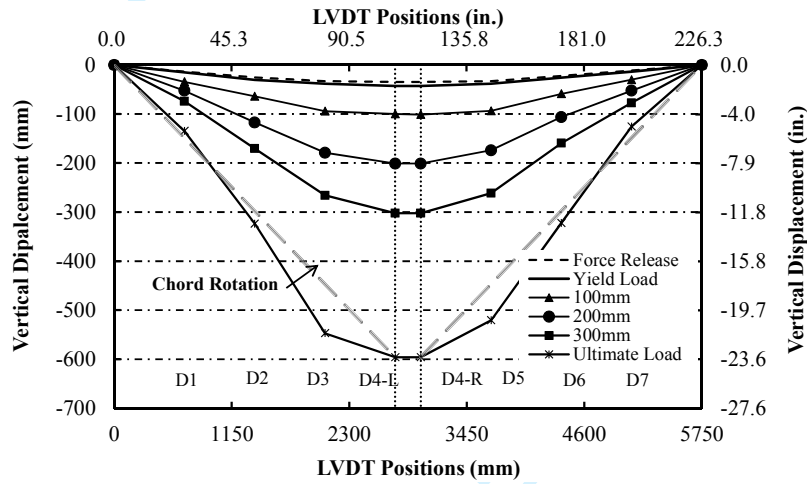
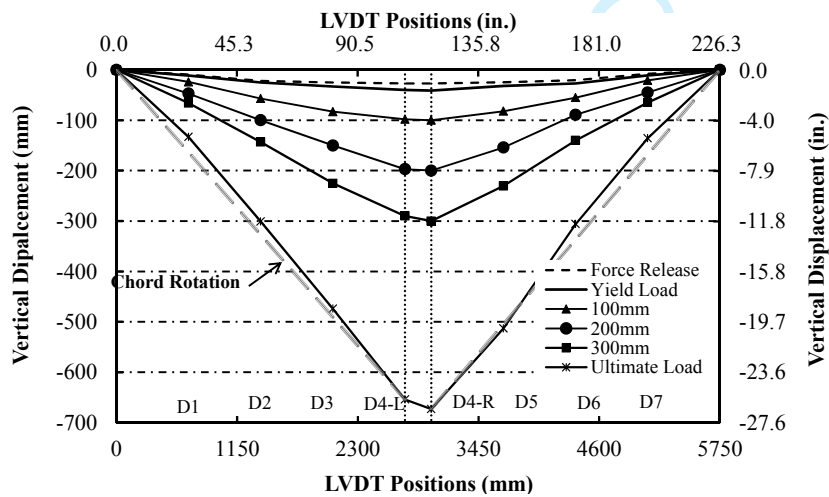

Fig. 14– Prestressed force in the tendon of all specimens



(a)



(b)

Fig. 15– Deformation shape of test specimens: (a) RCSL; (b) PCSL-0.6

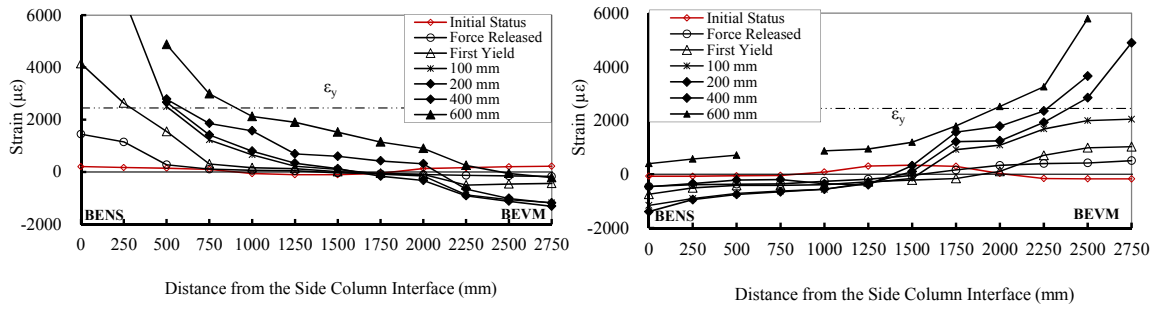

(a)

(b)

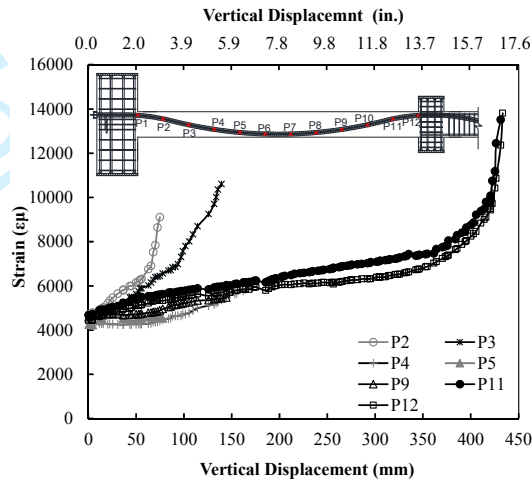

(c)

Fig. 16– Strain gauge results of PCSL-0.6: (a) top non-prestressed rebar; (b) bottom non-prestressed rebar; (c) prestressed tendon

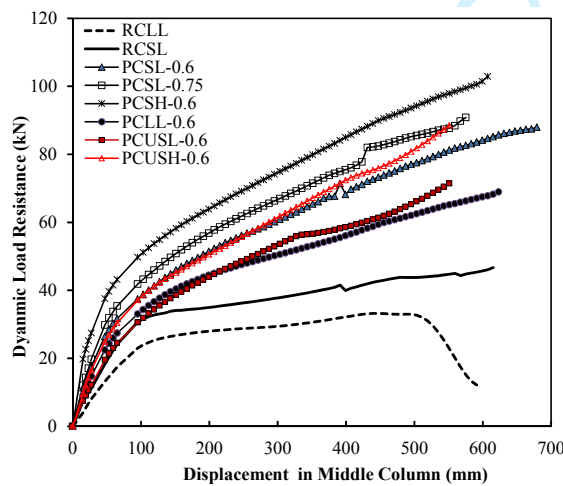

Fig. 17– Dynamic performance of the specimens

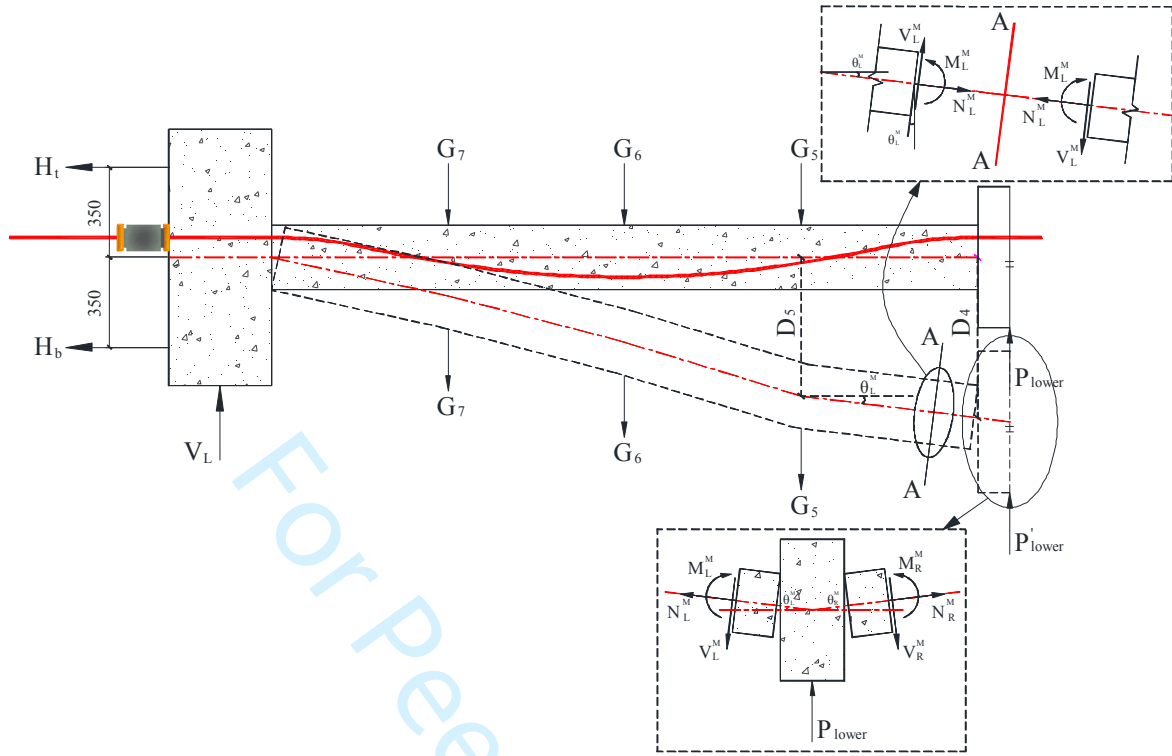
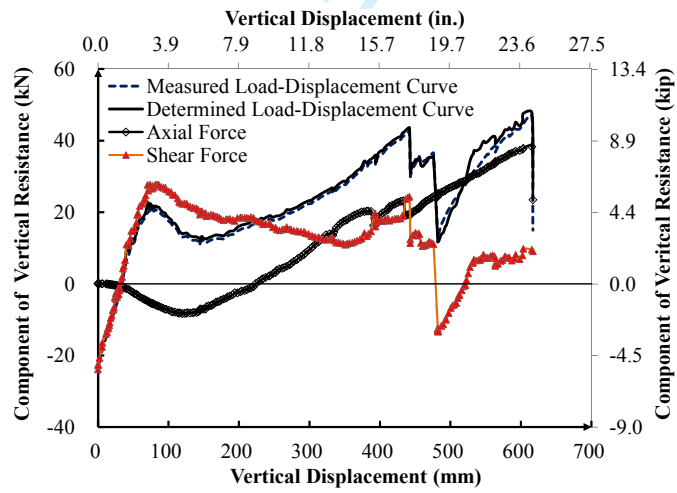
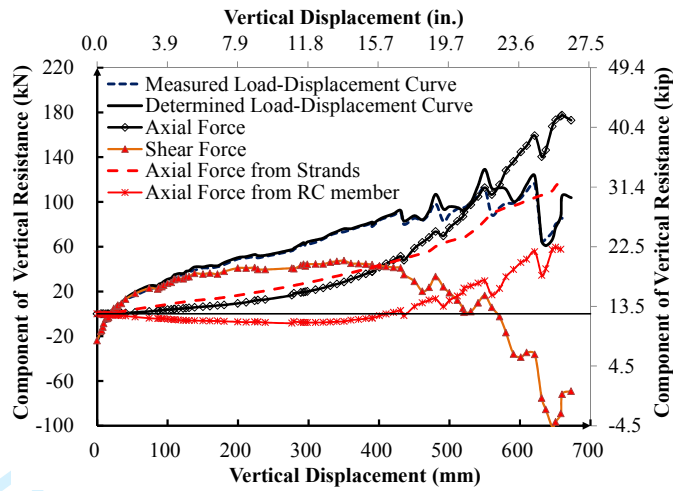

Fig. 18– The relationship of internal forces and the load resistance



(a)



(b)

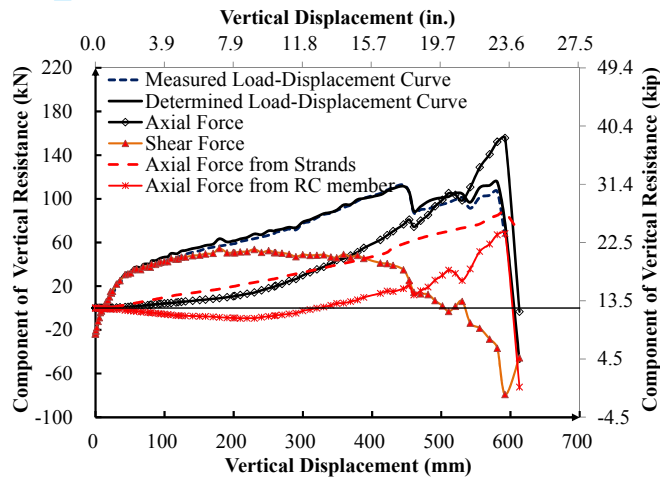

(c)

Fig. 19– Resistance contributions from axial and shear force (a) RCSL, (b) PCSL-0.6, (c)

PCSH-0.6

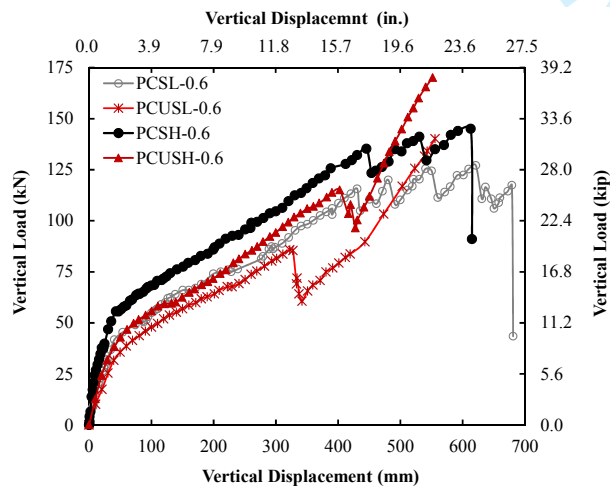

Fig. 20– Bonding effects on load-displacement curves