

## PDF hosted at the Radboud Repository of the Radboud University Nijmegen

The following full text is a publisher's version.

For additional information about this publication click this link.

<http://hdl.handle.net/2066/58910>

Please be advised that this information was generated on 2018-07-08 and may be subject to change.

# **Hereditary Deaf-Blindness**

**clinical and genetic aspects**



**Ronald Pennings**



# HEREDITARY DEAF-BLINDNESS

*clinical and genetic aspects*

Print: PrintPartners Ipskamp, Enschede

Cover: The U of Usher is shown in hand alphabet on the cover, whereas the word Usher is shown on the rearside of this thesis. The hands belong to the parents of the author.

ISBN 90-9017938-0

© 2004 by Pennings, Ronald Johannes Elisabeth  
Hereditary Deaf-Blindness, clinical and genetic aspects.  
Thesis University Nijmegen.

All rights reserved. No part of this publication may be reproduced in any form or by any means, electronically, mechanically, by print or otherwise without written permission of the copyright owner.

# HEREDITARY DEAF-BLINDNESS

*clinical and genetic aspects*

Een wetenschappelijke proeve  
op het gebied van  
de Medische Wetenschappen

PROEFSCHRIFT

Ter verkrijging van de graad van doctor  
aan de Katholieke Universiteit Nijmegen,  
op gezag van de Rector Magnificus, prof. dr. C.W.P.M. Blom,  
volgens besluit van het College van Decanen  
in het openbaar te verdedigen op  
donderdag 29 april 2004  
des namiddags om 1:30 precies

door

Ronald Johannes Elisabeth Pennings  
geboren op 17 april 1975  
te 's-Hertogenbosch

Promotores: Prof. Dr. C.W.R.J. Cremers  
Prof. Dr. A.F. Deutman

Copromotor: Dr. H. Kremer  
Dr. P.L.M. Huygen

Manuscriptcommissie: Prof. Dr. H.G. Brunner (voorzitter)  
Prof. Dr. G. Van Camp (Universiteit Antwerpen)  
Prof. Dr. C.H. van Os  
Prof. Dr. H.P.H. Kremer  
Prof. Dr. L.L.A. Monnens

**This study was supported by grants from:**

Forschung contra Blindheit - Initiative Usher syndrom - c.V.  
ZonMw (AGIKO-project)  
Nijmegen ORL Research Foundation  
Heinsius Houbolt Foundation

Publication of this thesis was financially supported by: Audire, Oticon Nederland, Beter Horen, Veenhuis Medical Audio, EmiD audiologische apparatuur, Beltone Nederland, Stichting Atze Spoor Fonds, Zon MW, ALVA BV, Glaxo Wellcome, URSAPHARM Benelux BV, Kooij Optiek Hoortoestellen, Schering Plough, UCB Pharma, Mediprof & Carl Zeiss.

tu remanebis amicus maximus perpetuo



# CONTENTS

## ABBREVIATIONS

## PREFACE AND AIMS OF THE STUDY

	<i>page</i>
<b>CHAPTER 1: GENERAL INTRODUCTION</b>	<b>13</b>
1.1 Usher syndrome	15
1.2 Wolfram syndrome	31
1.3 A molecular genetic approach to sensorineural hearing impairment	45
1.4 A review of progressive phenotypes in nonsyndromic autosomal dominant hearing impairment. <i>R J E Pennings, P L M Huygen, G Van Camp, C W R J Cremers</i> Audiological Medicine 2003,1 47-55	79
<b>CHAPTER 2: METHODS</b>	<b>95</b>
2.1 Characterising and distinguishing progressive phenotypes in nonsyndromic autosomal dominant hearing impairment. <i>P L M Huygen, R J E Pennings, C W R J Cremers</i> Audiological Medicine 2003,1 37-46	97
<b>CHAPTER 3: USHER SYNDROME</b>	<b>111</b>
3.1 Variable clinical features in patients with <i>CDH23</i> mutations (USH1d-DFNB12). <i>R J E Pennings, V Topsakal, L Astuto, A P M de Brouwer, M Wagenaar, P L M Huygen, W J Kimberling, A F Deutman, H Kremer, C W R J Cremers</i> Otology & Neurotology 2004, conditionally accepted	113
3.2 Evaluation of visual impairment in Usher syndrome Ib and Usher syndrome IIa. <i>R J E Pennings, P L M Huygen, D J Orten, M Wagenaar, A van Aarem, H Kremer, W J Kimberling, C W R J Cremers</i> Acta Ophthalmologica Scandinavica 2004, in press	129

- 3.3 Pure tone hearing thresholds and speech recognition scores in Dutch patients carrying mutations in the *USH2A* gene. 147  
*R.J.E. Pennings, P L M. Huygen, M.D. Weston, A. van Aarem, M Wagenaar, WJ Kimberling, C.W.R.J. Cremers*  
*Otology & Neurotology* 2003;24 58-63.
- 3.4 Analysis of optokinetic and vestibular responses related to advancing age and increasing visual impairment in Usher syndrome type IIa. 161  
*P L M Huygen, R.J.E. Pennings, M.G M. Nicolassen, A. van Aarem, M.D. Weston, A.F. Deutman, W.I.M. Verhagen, H. Kremer, W.J. Kimberling, C.W.R.J. Cremers*  
*Experimental Brain Research* 2004, submitted.
- 3.5 *USH2A* mutation analysis in 70 Dutch families with Usher syndrome type II. 189  
*R.J.E. Pennings, H. te Brinke, M D. Weston, A. Claassen, D.J. Orten, H. Weekamp, A. van Aarem, P.L.M. Huygen, A.F. Deutman, L.H. Hoefsloot, F P M. Cremers, C.W.R J Cremers, W.J. Kimberling, H. Kremer*  
*Human Mutation* 2004; conditionally accepted.
- 3.6 Usher syndrome type III can mimic other types of Usher syndrome. 203  
*R.J.E. Pennings, R.R. Fields, P.L.M Huygen, A.F. Deutman, W.J. Kimberling, C.W.R.J. Cremers*  
*Annals of Otology, Rhinology & Laryngology* 2003;112:525-530.
- CHAPTER 4: WOLFRAM SYNDROME 217
- 4.1 Sex-related hearing impairment in Wolfram syndrome patients identified by inactivating *WFS1* mutations. 219  
*R.J.E Pennings, P.L.M. Huygen, J.M.W. van den Ouweland, K. Cryns, L.D. Dikkeschei, G. Van Camp, C W.R.J. Cremers*  
*Audiology Neuro-Otology* 2004;9:51-62.

CHAPTER 5:	AUTOSOMAL DOMINANT NONSYNDROMIC LOW-FREQUENCY HEARING IMPAIRMENT (DFNA6/14)	239
5.1	Progression of low-frequency sensorineural hearing loss (DFNA6/14-WFS1) <i>R J E Pennings, S J H Bom, K Cryns, K Flothmann, P L M Huygen, H Kremer, G Van Camp, C W R J Cremers</i> Archives of Otolaryngology-Head & Neck Surgery 2003,129:421-426	241
CHAPTER 6:	GENERAL DISCUSSION	255
CHAPTER 7:	SUMMARY AND CONCLUSIONS	267
	Summary and conclusions	269
	Samenvatting en conclusies	275
	Dankwoord	283
	Curriculum Vitae	285
	List of publications	286

## ABBREVIATIONS

ANCOVA	analysis of covariance
ANOVA	analysis of variance
ARTA	age-related typical audiograms
CED <sub>OKAN</sub>	cumulative eye displacement during OKAN
DFNA	autosomal dominant inherited sensorineural HI
DFNB	autosomal recessive inherited sensorineural HI
DP	directional preponderance
FFS	functional field score
FAS	functional acuity score
FVS	functional vision score
G	gesamt amplitude
HI	hearing impairment
IHC	inner hair cell
OHC	outer hair cell
OKAN	optokinetic afternystagmus
OKN	optokinetic nystagmus
RP	retinitis pigmentosa
RPA	retinitis punctata albescens
RPE	retinal pigment epithelium
RPSP	retinitis pigmentosa sine pigmento
SNP	single nucleotide polymorphism
SPV	slow phase velocity
T	time constant
T <sub>OKAN</sub>	OKAN time constant
TFA	threshold features array
USH2a	Usher syndrome type IIa (genetic subtype)
USH2A	locus of USH2a
<i>USH2A</i>	gene of USH2a
V <sub>OKAN</sub>	initial velocity of OKAN
V	initial velocity
VA	visual acuity
VAS	visual acuity score
VFS	visual field score
VOR	vestibulo-ocular reflex

# PREFACE AND AIMS OF THIS STUDY

## *Preface*

This thesis is part of the ongoing Nijmegen Usher syndrome research project, which is directed by Cor Cremers. In this project, families and individual patients with Usher syndrome are contacted and examined to evaluate their clinical features. In addition, blood samples are taken from the patients and their relatives to perform linkage studies and mutation analysis of Usher syndrome genes. These genetic studies are performed at the Center for the Study and Treatment of Usher syndrome, in the Boys Town National Research Hospital in Omaha, USA (Bill Kimberling) and, since 2000, DNA samples of Usher syndrome families are also analysed at the Department of Human Genetics of the UMC St Radboud at Nijmegen, the Netherlands (Hannie Kremer, Heleen te Brinke, Lies Hoefsloot and Frans Cremers). The first Nijmegen PhD thesis on Usher syndrome has been written by Annelies van Aarem (1996, Heterogeneity in the Usher syndrome) and the second PhD study was written by Mariette Wagenaar (2000, The Usher syndrome, a clinical and genetic correlation).

This is the third thesis, bearing on the third Usher syndrome project that started in april 2001. It was facilitated by a grant from the German foundation Forschung Contra Blindheit- Initiative Usher syndrom (Mr. And Mrs. Ger & Angelika König). At the beginning of this project, the PhD student involved had to learn how to perform a family study. A family with low-frequency hearing impairment was examined and within two months mutations in the Wolfram syndrome 1 gene (*WFS1*) were found to be responsible for the hearing impairment (DFNA6/14) in that family. As Wolfram syndrome, similar to Usher syndrome, is a deaf-blindness syndrome, it was decided to study families with this syndrome as well. This was done in close cooperation with the Department of Medical Genetics of the University of Antwerp in Antwerp, Belgium (Guy Van Camp & Kim Cryns), and the Department of Clinical Chemistry of the Isala Clinics in Zwolle, the Netherlands (Bert Dikkeschei & Jody van den Ouweland). In May 2003, the fourth Nijmegen Usher syndrome research project has started (Rutger Plantinga). This project will study the genotype-phenotype correlation in Finnish Usher syndrome type III patients and is performed in close cooperation with Finnish scientists, who have examined many of these patients exhibiting progressive hearing loss (Leenamajja Kleemola) and who have cloned the *USH3* gene (Eeva-Marja Sankila).

## *Aims of the study*

1. To develop in more detail a useful method to analyse audiometric data and thus to classify and distinguish families with hearing impairment in order to guide future linkage and gene identification studies.
2. To further delineate the phenotype of several genetic subtypes of Usher syndrome, hereby focusing on audiometric, ophthalmological and vestibular examination results.
3. To perform linkage and mutation analysis of the *USH2A* gene in Dutch Usher syndrome type II families in order to support the DNA diagnostics and genetic counselling of Usher syndrome families.
4. To evaluate and analyse the audiovestibular features of Wolfram syndrome patients and their relatives.
5. To evaluate and analyse the audiometric findings associated with DFNA6/14.

The general introduction is divided into four sections. In the first two sections specific attention is paid to Usher syndrome and Wolfram syndrome. The historical perspective, clinical characteristics and genetic characteristics are described for these two syndromes. In the third section, a molecular genetic approach to sensorineural hearing impairment is given, in which the currently identified genes are classified and described according to their function in the inner ear. The last section is a review of progressive phenotypes in nonsyndromic autosomal dominant hearing impairment that was published in *Audiological Medicine*.

The results of this study are presented in five different chapters. Chapter 2 describes a method to analyse audiometric data. Chapter 3 presents the phenotype-genotype correlation studies performed on several different groups of genotyped Usher syndrome patients (*USH1b*, *USH1d*, *USH2a* en *USH3*). Chapter 4 presents the audiovestibular findings in 11 Wolfram syndrome patients and Chapter 5 shows the results of audiovestibular examinations in two new DFNA6/14 families. In Chapter 6 the results of this PhD study are discussed and related to the aims of this study. Finally, in Chapter 7 the summary and conclusions of this study are presented in English and in Dutch.



# CHAPTER 1

## GENERAL INTRODUCTION





# 1.1

---

## USHER SYNDROME



## HISTORICAL PERSPECTIVE OF USHER SYNDROME.

In the second part of the 19th century, the first reports on hereditary causes of deafness and blindness were published. One of the first pioneers in research of the deaf was Sir William Wilde, an Irish otologist. In 1853, about a decade before the introduction of Mendel's laws, William Wilde was the first to describe autosomal dominant inheritance of hearing impairment (HI) in Irish families.<sup>1</sup> In 1857, Donders, the famous Dutch ophthalmologist, described the bone spicule formation we now know as retinitis pigmentosa (RP).<sup>2</sup> Alfred Graefe was the first ophthalmologist who noticed the combination of deafness and RP in 3 related patients and suspected a hereditary cause. His uncle, the famous ophthalmologist Albrecht von Graefe, described these three cases in his scientific journal in 1858.<sup>3</sup> During the 19th century, the first large studies of populations with HI were conducted and it was noted that in many cases the HI was accompanied by other disorders such as ophthalmological diseases, mental retardation, epilepsy and polydactyly.<sup>4,5</sup> Liebreich, another German ophthalmologist, performed systematic examinations on a large group of 341 deaf inhabitants of Berlin. The proportion of RP in this group of deaf patients was high, and remarkably, even higher in consanguineous Jewish families.<sup>4</sup>

At that time, Gregor Johann Mendel, a monk and biologist from Brno who performed studies on pea pod plants, publishes his "Versuche über Pflanzen-Hybriden", which later became the basis for the establishment of modern genetics.<sup>6</sup> In this work he proposed the principles of heredity and introduced the concept of dominantly and recessively inherited genes to explain how characteristic features can be repressed in one generation, but appear in the next. Although his work already had been published in 1866, it was relatively unappreciated until the beginning of the 20<sup>th</sup> century.

Arthur Hartmann, a German otologist, was one of the first to describe an indirect (recessive) inheritance pattern of HI in his book on deaf-mutes published in 1880.<sup>7</sup> A chapter on deafness and blindness again accurately stressed the combination of profound deafness and RP and its relation to consanguineous marriages. He also emphasised the difficulties in educating individuals with visual as well as HI and promoted the oral method for the education of hearing impaired individuals, which at that time was not generally accepted. In 1919, De Wilde was one of the first Dutch doctors who reported on individuals with a combination of HI and

visual impairment in the Netherlands. He concluded that 38 of 167 (22%) Dutch RP patients also suffered from HI; 13 of them had been born in consanguineous marriages.<sup>8</sup>

The syndromal combination of HI and RP was finally named after the Scottish ophthalmologist Charles Howard Usher (1865-1942), born 7 years (!) after the first description of deafness and RP in a patient and two of his sibs by Albrecht von Graefe. Charles Usher was the fourth son in a prominent Edinburgh family. After studying at Cambridge University he got his medical degree at the St Thomas

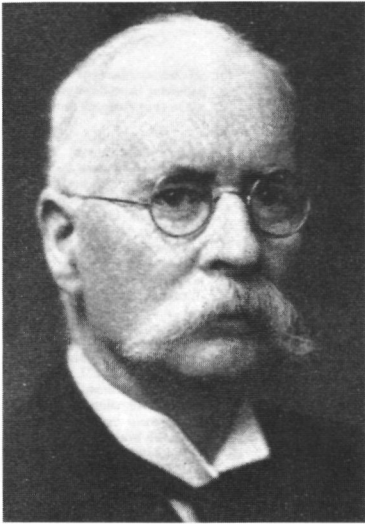

Charles Usher (1865-1942)

Hospital in London. He was very dedicated to his work and spent much time on performing extensive family studies, especially in the Highlands of Scotland. Influenced by his mentor Edward Nettleship, an eminent ophthalmologist of that time, he decided to study a population of visually impaired patients.<sup>9</sup> The results of these elaborate studies were described in his book entitled "*On the inheritance of retinitis pigmentosa, with notes of cases*", which was published in 1914.<sup>10</sup> In this book he only briefly mentioned that 19 of 69 RP patients to some degree had HI. After his presentation in 1935 of the Bowman Lecture "*On a few hereditary eye affections*", in which several families with eye disorders were

presented to a large group of scientists, his name became an eponym for the syndromal combination of RP and HI.<sup>11</sup> This is very remarkable, because in his Bowman lecture he did **not** mention the association of HI and RP. Regarding history, it should have been more appropriate to name the syndrome after Alfred Graefe or after Liebreich.

In the past century, the studies on Usher syndrome were conducted from two clinical perspectives. The studies by Usher,<sup>10</sup> Bell,<sup>12</sup> Nettleship,<sup>13</sup> Von Wibaut<sup>14</sup> and Kjerrumgaard<sup>15</sup> were performed from an ophthalmological perspective, i.e. data on groups of RP patients were collected and it was evaluated how many of them also were hearing impaired. The studies performed from an otological perspective merely focused on the examination of large groups of deaf patients attending schools for the deaf, who in addition had RP. In three Scandinavian countries,

Norway,<sup>16</sup> Sweden<sup>17</sup> and Denmark,<sup>18</sup> examinations of large groups of deaf individuals were performed on a national scale and two observational studies, by Hallgren<sup>19</sup> in 1959 and Nuutila<sup>20</sup> in 1970, comprised nationwide evaluations of Usher syndrome patients in Sweden and Finland, respectively.

Hallgren was the first to report on the prevalence of Usher syndrome; it was estimated to be about 3 per 100,000 inhabitants.<sup>19</sup> This estimate was based on his study of the Swedish deaf population and on the international literature available at that time. At present, the prevalence of Usher syndrome is estimated to range from 3.5 – 6.2 per 100,000.<sup>20-26</sup> It accounts for about 3-6 % of the congenital types of deafness, about 18% of the pigmentary retinopathies and over 50% of all patients with deafblindness.<sup>27</sup>

Already in 1922 Julia Bell, one of the first prominent female geneticists, was the first to report on a difference in the degree of HI in Usher syndrome.<sup>12</sup> She emphasised that there were two groups of patients, one in which HI was profound and a second one in which the patients suffered from a moderate to severe type of HI. Hallgren in 1959 suggested that these two clinical types of Usher syndrome might be caused by two different genes.<sup>19</sup> In his studies, Hallgren also described psychiatric problems in Usher syndrome patients and for some time this was regarded as a separate type of Usher syndrome, which was referred to as the Hallgren syndrome. To date, psychiatric illness is no longer defined as a key feature in any of the known types of Usher syndrome.

Whereas Julia Bell already emphasised the clinical heterogeneity of Usher syndrome in 1922, several other studies also reported on the variability in clinical features. In 1977, this finally led to the original classification described by Davenport and Omenn (Table 1, adjusted to recent findings).<sup>28</sup> Although mental retardation and psychosis at that time were suspected to be part of the syndrome, Davenport and Omenn decided to exclude these features from the classification, because they regarded them to be secondary to the inherent double sensory deprivation.

## GENETIC AND CLINICAL FEATURES OF USHER SYNDROME

Usher syndrome is divided into three clinical types (Table 1). These three clinical types are further divided into several genetic subtypes on the basis of the identification of loci and genes as is shown in Table 2. In the next paragraphs, the genetic characteristics are described, followed by a detailed description of the audiological, vestibular and ophthalmological features of the 3 clinical types of Usher syndrome.

Table 1. Original clinical classification by Davenport and Omenn (1977)<sup>28</sup>; adjusted to recent findings.

	Hearing impairment	Visual impairment	Vestibular function
Usher type I	Severe to profound congenital deafness	RP onset before puberty	Vestibular areflexia
Usher type II	Moderate to severe hearing loss	RP onset after puberty	Normal/variable
Usher type III	Progressive hearing loss	RP	Variable

RP: retinitis pigmentosa.

### *Genetic characteristics of Usher syndrome*

Since the beginning of the eighties of the past century, family studies have been initiated with the purpose of mapping and identifying the genes involved in Usher syndrome. The first locus for Usher syndrome (USH2A) was localised to chromosome 1q41 by Kimberling et al. in 1990.<sup>29</sup> In the past decade several genes were linked and cloned and it was proven that Usher syndrome was more heterogeneous than originally had been thought. At present, 11 loci, including 7 identified genes, are known to be involved in Usher syndrome.<sup>30</sup> In Table 2, the presently known to be involved loci and genes are shown for the different types of Usher syndrome.

Several useful reviews on the molecular genetics of Usher syndrome have appeared recently.<sup>46-49</sup> Some of the genes found to be involved in Usher syndrome are also involved in nonsyndromic types of hearing loss or RP. For example, *MYO7A*, the gene involved in Usher syndrome Ib (USH1b), also harbours mutations in families with DFNA11,<sup>50</sup> a nonsyndromic dominant type of sensorineural HI, as well as in families with DFNB2,<sup>51</sup> a nonsyndromic recessive type of sensorineural HI. Other genetic subtypes of Usher syndrome and nonsyndromic types of HI caused by mutations in the same gene are Usher

syndrome Ic (USH1c) and DFNB18,<sup>52</sup> and Usher syndrome Id (USH1d) and DFNB12.<sup>36</sup> In the *USH2A* gene a frequent mutation (Cys759Phe) causes about 4.5% of the cases of nonsyndromic recessive RP.<sup>53</sup> The most recent knowledge on the function of the proteins of the known Usher syndrome genes and the functional complexes they form is described in the section “A molecular genetic approach to sensorineural hearing impairment”.

Table 2. Genetic subtypes of Usher syndrome.

Type	Genetic subtype	Chromosomal location	Gene	Mouse model	OMIM <sup>31</sup>	References
Type I	USH1a	14q32	-	-	276900	32
	USH1b	11q13.5	<i>MYO7A</i>	<i>Shaker1</i>	276903	33
	USH1c	11p15.1	<i>USH1C</i>	-	276904	34, 35
	USH1d	10q	<i>CDH23</i>	<i>Waltzer</i>	601067	36, 37
	USH1e	21q	-	-	602097	38
	USH1f	10q21-22	<i>PCDH15</i>	<i>Ames</i> <i>Waltzer</i>	602083	39, 40
	USH1g	17q24-15	<i>SANS</i>	<i>Jackson</i> <i>shaker</i>	607696	41
Type II	USH2a	1q41	<i>USH2A</i>	-	276901	42
	USH2b	3p23-24.2	-	-	276905	43
	USH2c	5q14.3-21.3	-	-	605472	44
Type III	USH3	3q21-25	<i>USH3</i>	-	606397	45

OMIM: Online Mendelian Inheritance in Man <sup>31</sup>

### Hearing impairment

Usher syndrome type I is characterised by congenital severe to profound HI. The patients have a disturbed speech-language development and most of them will have their education at schools for the deaf. Because their visual handicap will more and more affect their normal daily activities with increasing age, these patients will benefit from early cochlear implantation followed by an intensive auditory rehabilitation program.<sup>54,55</sup> The rehabilitation of Usher syndrome patients requires little extra effort when compared to other prelingually deaf patients and all of them reported considerable advantages in hearing abilities and social life.<sup>55</sup> It was shown that Usher syndrome patients have better logopedic results when they receive their cochlear implant at younger ages.<sup>56</sup> Histopathologic studies of the cochlear nuclei in 2 Usher syndrome type I patients have shown that these patients with long-term sound deprivation only have minor degenerative changes in the dorsal and ventral cochlear nucleus and therefore will benefit from cochlear implantation because the central auditory system is intact.<sup>57</sup>



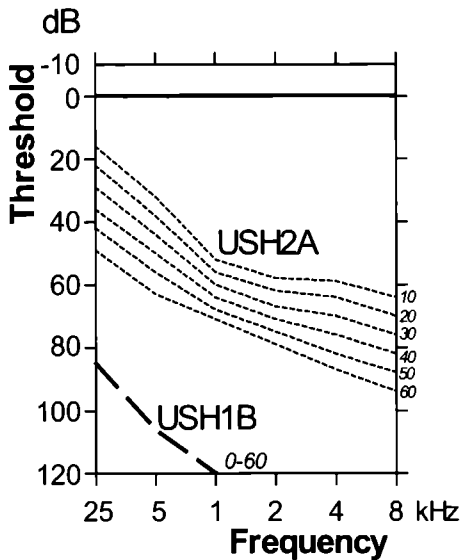

Figure 1 ARTA for USH1b and USH2a <sup>58-59</sup>  
Age in italics (year)

Usher syndrome type I patients with congenital severe to profound HI can clearly be distinguished from Usher syndrome type II patients, who have a congenital moderate to severe HI that is more prominent in the high-frequency range. This is shown in Figure 1 by the Age Related Typical Audiograms (ARTA) of Usher syndrome IIa (USH2a) patients and USH1b patients <sup>58-59</sup>. Usher syndrome type II patients can communicate by telephone at least up to the age of 50-60 years and will benefit from hearing aids. Currently, it is debated as to whether or not Usher syndrome type II shows progression of HI. Previously, the suggestion of USH2a patients

showing progressive HI was made in the reports by Wagenaar et al <sup>59</sup> and van Aarem et al <sup>60</sup>. In Chapter 3.3 of this thesis, it is demonstrated that a selected sample of USH2a patients, all identified by mutation analysis, shows progression of HI by about 0.5 dB/year, which in the low frequencies cannot be attributed to presbycusis alone <sup>58</sup>.

Hmani-Aifa et al reported that the HI in a Tunisian family with USH2a was significantly worse than the HI in the only currently known Usher syndrome type IIb (USH2b) family also originating from Tunisia <sup>61</sup>. In addition, they also stated the HI in these two families to be non-progressive. In the future, when more genes for Usher syndrome type II will be cloned, it will be possible to evaluate the associated HI in different genetic subtypes.

Besides Usher syndrome type I and II, Usher syndrome type III can be distinguished, mainly by its characteristic progression of HI. Although Usher syndrome type III is considered to be a rare type (2%) of Usher syndrome, it was noticed that in Finland about 40% of the Usher syndrome patients are having this progressive type of HI <sup>62</sup>. The first study of this patient group was performed by

Karjalainen et al.<sup>63</sup>, who examined 18 patients with progressive HI. This study was expanded by Pakarinen and Sankila, in order to clone the responsible gene for Usher syndrome type III and to describe the clinical features of this type of Usher syndrome. In an elaborate, relatively unknown study, Pakarinen et al.<sup>64</sup> described 42 Usher syndrome type III patients. They stated that HI in Usher syndrome type III most often has a postlingual onset and progresses to severe to profound HI in a variable duration of 5 to 30 years. Thus, at higher ages these patients have a hearing loss that resembles Usher syndrome type I but, unlike Usher syndrome type I patients, most of them communicate by speech.<sup>64</sup> On the basis of this work, Sankila et al. were able to map the *USH3* gene to chromosome 3q<sup>65</sup> and to clone the *USH3* gene in 2001.<sup>66</sup> A founder mutation (Y100X) in this gene was responsible for most of the Finnish Usher syndrome type III patients, which were all identified by progressive HI. In the Netherlands, Usher syndrome type III is rare. The clinical examination results of the first and so far only Dutch *USH3* family are reported in Chapter 3.6 of this thesis.<sup>67</sup>

### *Visual impairment*

The visual impairment in Usher syndrome is caused by RP (Figure 2). Synonyms are pigmentary retinopathy and tapetoretinal degeneration, however, RP is now most commonly used in literature. The term retinitis is semantically incorrect,

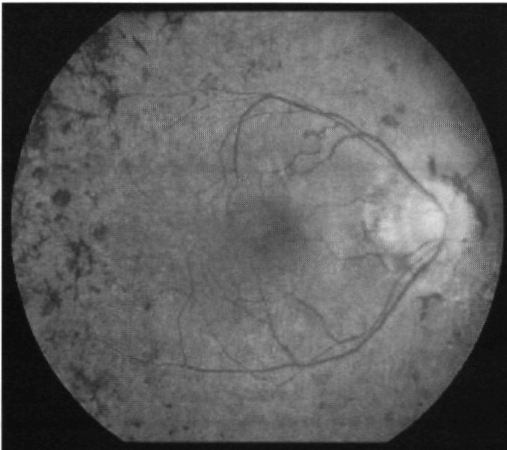

Figure 2. Retinitis pigmentosa of the right eye

because retinitis refers to inflammation of the retina, which is unusual for the disease. The term pigmentosa refers to the characteristic melanin depositions in the retina in more advanced stages of RP. The intraretinal deposition of pigment and arteriolar narrowing characterise the fundus appearance in patients with RP and are prerequisites for the diagnosis. As the deterioration of retinal photoreceptors progresses, cells and pigment particles from the

retinal pigment epithelium detach from Bruch's membrane and accumulate in the thinner retina where they form pigmented bone-spicule formations around the

thin-walled blood-vessels.<sup>67,68</sup> On funduscopy, bone spicules can be clearly seen, especially in the mid-periphery of the retina they are most prominent. In addition, with the developing atrophy of the retina, the retinal blood vessels tend to attenuate and the disk will develop a waxy appearance (Figure 2). Atypical forms of RP have also been reported in Usher syndrome patients. Retinitis pigmentosa sine pigmento, i.e. RP without the characteristic pigment depositions and retinitis punctata albescens, i.e. the presence of multiple scattered white dots in the mid-periphery of the retina, were seen in the Dutch Usher syndrome type III family.<sup>69</sup> Retinitis punctata albescens was also described in another Dutch Usher syndrome patient,<sup>70</sup> in whom we recently identified a mutation in the Usher syndrome type IIa gene.<sup>71</sup> In his thesis (1976), Cremers already described a brother and sister with Usher syndrome type I and retinitis pigmentosa sine pigmento.<sup>72</sup>

RP presents with nyctalopia (nightblindness) in the first decade of life or during early adolescence. This is mainly due to degeneration of the rods in the retina, however, in the following decades progressive deterioration of rods as well as cones gradually and increasingly affects vision. As the disease progresses over the years, constriction of the visual fields leads to tunnel vision.<sup>68</sup> In addition, visual acuity starts to deteriorate, related to a loss of cones in the central retina. Visual acuity can be disturbed not only by degeneration of cones in the retina, but also by the development of posterior subcapsular cataract. This type of cataract can be removed by surgery, however, not all patients will benefit from such treatment due to the poor visual acuity that is seen in some of them.<sup>68</sup> To evaluate the deterioration of visual field size, Goldmann perimetry is used. Before signs of RP can be seen on funduscopy, subnormal electroretinogram values may already indicate RP at young age.<sup>73</sup> The early diagnosis of RP by electroretinography was first advocated by Vernon et al.<sup>74</sup> Their recommendation was based on the finding that the electroretinogram may detect the presence of retinal disease secondary to RP before the onset of signs or symptoms of this disorder.<sup>74</sup>

Several studies have emphasised a more unfavourable course in Usher syndrome type I than in Usher syndrome type II.<sup>75-77</sup> It is also emphasised that night blindness starts several years later in Usher syndrome type II than in Usher syndrome type I.<sup>78</sup> However, other studies were not able to detect significant differences in this regard between Usher syndrome type I and II, although they described an apparently worse outcome in Usher syndrome type I patients.<sup>79,80</sup> Unfortunately, these studies only comprised cross-sectional analyses of data in

patients who were selected on the basis of clinical findings and not on the basis of mutation analysis. In Chapter 3.2 of this thesis, we identified no difference in progression of visual field size and visual acuity in cross-sectional analysis between USH1b and USH2a. Longitudinal analysis of several USH2a patients, however, suggested a later onset age and a higher rate of deterioration in these patients.<sup>81</sup> It is important to mention that not all Usher syndrome patients will become blind, however, the prevalence of blindness increases with age. About 40% of the patients will be blind by the fifth decade, 60% by the sixth decade and 75% by the seventh decade of life, whereas the patients who are not blind by the latter ages will have developed severe visual impairment.

In patients with Usher syndrome type III, a high proportion of hypermetropia with a high degree of astigmatism was found in refraction tests.<sup>64,82</sup> This was found to be more frequent in Usher syndrome type III than in the general population. In addition, most of the progression of visual deterioration occurred below the age of 40 and was continuous up to that age. Visual acuity was severely impaired by the age of 37 and the visual fields were constricted without peripheral islands at an average age of 30 years.<sup>82</sup>

#### *Vestibular impairment*

Patients with Usher syndrome type I have vestibular areflexia by definition (Table 1). These patients have delayed motor milestones and most of them are not able to walk independently at age below 18 months. Therefore, children with profound HI and delayed motor milestones should be tested for vestibular areflexia. This is best done by using a rotatory chair, while the child is seated on a parent's lap. Patients with vestibular areflexia also have difficulties in learning to ride a bicycle. Vestibular areflexia in Usher syndrome Ib patients and in the related mouse model (*shaker1*) is caused by peripheral dysfunction of the labyrinth and malfunction of vestibular hair cells.<sup>83-85</sup> In the section on "*A molecular genetic approach to sensorineural hearing impairment*" it is described that the proteins encoded by the USH1b, USH1c, USH1d and USH1g genes interact and thus shape the stereocilia of the inner ear hair cells. These proteins are likely to have a similar function in vestibular sensory epithelia and therefore, similarly to the cochlea, normal function is disturbed, by abnormal protein expression.

Although vestibular function in Usher syndrome type II has always been designated as “normal”, in Chapter 3.4 it is shown that this is often not the case.<sup>86</sup> Over 15 years of vestibular examinations of Usher syndrome type II cases has shown that the results of optokinetic nystagmus (OKN) and vestibulo-ocular reflex (VOR) examinations were seldom normal.<sup>86</sup> Variable vestibular findings have been reported in Usher syndrome type III patients.<sup>64</sup> In about 50% of them a reduced response on caloric testing was found.<sup>66</sup> Recently, Otterstedde et al. proposed a new classification for Usher syndrome type I.<sup>89</sup> Their clinically identified Usher syndrome type I patients with profound HI were divided into a group with vestibular areflexia (n=17) and a group with normal vestibular function (n=9).<sup>89</sup> However, no mutation or linkage analysis was performed to genetically classify these patients and thus it could have been possible that these 9 patients from Germany were in fact Usher syndrome type III patients with early, severe progression of HI and intact vestibular responses.

## REFERENCES

- 1 Wilde WR Practical observations on aural surgery and the nature and treatment of diseases of the ear Philadelphia Blanchard and Lea Londen and Boston Churchill 1853
- 2 Donders F. Beitræge zur pathologischen Anatomie des Auges 2 Pigmentbildung in der Netzhaut. Arch Fr Ophthalmol 1857;3 139-165.
- 3 Von Graefe A Vereinzelte Beobachtungen und Bemerkungen Exzeptionelles Verhalten des Gesichtsfeldes bei Pigmentenartung der Netzhaut Von Graefe's Arch Ophthal 1858;4:250-253
- 4 Liebreich R Abkunft aus Ehen unter Blutverwandten als Grund von Retinitis Pigmentosa Dtsch Arch Klin Med 1861;13:53-55.
- 5 Lee CG Notes on the ophthalmic conditions of deaf-mutes Br Med J 1883;2:1184.
- 6 Mendel GJ Versuche uber Pflanzen-Hybriden Verhandl d Naturfösch Ver in Brünn 1866;4:3-47.
- 7 Hartmann A. Taubstummheit und Taubstummensbildung nach den vorhanden Quellen sowie nach eigenen Beobachtungen und Erfahrungen. Stuttgart Verlag Ferdinand Enke, 1880
- 8 De Wilde PA. Verwantschap en erfelijckheid bij doofstomheid en retinitis pigmentosa Academisch proefschrift Universiteit van Amsterdam Amsterdam, F van Rossem, 1919.
- 9 Beighton P, Beighton G. The man behind the syndrome Usher, Charles H. (1865-1942). Pp. 176-177
- 10 Usher CH On the inheritance of retinitis pigmentosa, with notes of cases R Lond Ophthalmol Hosp Rep 1914;19.130-236
- 11 Usher CH Bowman Lecture On a few hereditary eye affections Trans Ophthalmol Soc UK. 1935;55:164-245.
- 12 Bell J. Retinitis pigmentosa and allied diseases Pearson K (ed), The Treasury of Human Inheritance, London Cambridge Press 1922;2 1-29
- 13 Nettleship E. On retinitis pigmentosa and allied diseases. Roy Lond Ophthal Hosp Rep 1907-1908;7/1:151
- 14 Von Wibaut F. Studien uber Retinitis Pigmentosa. Klin Mbl Augenheilk 1931;87 298-307
- 15 Kjerrumgaard E Retinitis pigmentosa with special reference to otologic, neurologic and endocrine complications Acta Ophthal (Kbh) 1948;26 55-65
- 16 Uchermann V. de Dovstumme i Norge I o. II. Cammermeyers Forlag, Kristiania, 1869
- 17 Hennung EMBP. Ohrenartzliche Untersuchungen von Schulern der Taubstummschulen Schwedens; nebst Bemerkungen zur Frage des Unterrichts der Schwerhörigen Uppsala. Almqvist und Wiksele Boktryckeri 1928

- 18 Lindenov H The etiology of deaf-mutism with special reference to heredity. Dissertation Munksgaard, Copenhagen, 1945
- 19 Hallgren B Retinitis pigmentosa combined with congenital deafness, with vestibulo-cerebellar ataxia and mental abnormality in a proportion of cases A clinical and geneticostatistical study Acta Psychiatr Neurol Scand Suppl 1959,34:5-101
- 20 Nuutila A. Dystrofia retinae pigmentosa-dysacusis syndrome (DRD): a study of the Usher- or Hallgren syndrome. J Genet Hum 1970,18 57-88
- 21 Boughman J, Vernon M, Shaver K Usher syndrome, definition and estimate of prevalence from two high-risk populations J Chronic Dis 1983,36:595-603.
- 22 Grøndahl J Estimation of prognosis and prevalence of retinitis pigmentosa and Usher syndrome in Norway. Clin Genet 1987;31 255-264
- 23 Hope CI, Bunday S, Proops D, Fielder AR Usher syndrome in the city of Birmingham – prevalence and clinical classification. Br J Ophthalmol 1997,81:46-53.
- 24 Kimberling WJ, Möller C Clinical and molecular genetics of Usher syndrome J Am Acad Audiol 1995,6:63-72
- 25 Rosenberg T, Haim M, Hauch A-M, Parving A The prevalence of Usher syndrome and other retinal dystrophy-hearing impairment associations Clin Genet 1997;51 314-321
- 26 Spandau UH, Rohrschneider K. Prevalence and geographic distribution of Usher syndrome in Germany. Graefé's Arch Clin Exp Ophthalmol 2002;240:495-498
- 27 Keats BJB Genes and nonsyndromic hearing loss. J Comm Dis 2002;35 355-366
- 28 Davenport SLH, Omenn GS The heterogeneity of Usher syndrome, abstract. In: Littlefield JW, Ebbing FJG, Henderson JW (eds) Fifth International Conference on Birth Defects. Amsterdam, Excerpta Medica 1977:87-88
- 29 Kimberling WJ, Weston MD, Möller C, Davenport SLH, Shugart YY, Priluck IA, Martini A, Milani M, Smith RJH Localization of Usher syndrome type II to chromosome 1q. Genomics 1990,7 245-249
- 30 Van Camp G, Smith RJH. Hereditary Hearing Loss Homepage. URL <http://dnalab-www.uia.ac.be/dnalab/hhh/>, accessed September, 2003.
- 31 Online Mendelian Inheritance in Man, OMIM™ McKusick-Nathans Institute for Genetic Medicine, Johns Hopkins University (Baltimore, MD) and National Center for Biotechnology Information, National Library of Medicine (Bethesda, MD), 2000. World Wide Web URL. <http://www.ncbi.nlm.nih.gov/omim/> accessed September 2003
- 32 Kaplan J, Gerber S, Bonneau D, Rozet JM, Delrieu O, Briard ML, Ghazi I, Dufier JL, Frézal J, Munnich A. A gene for Usher syndrome type I (USH1A) maps to chromosome 14q. Genomics 1992,14 979-987
- 33 Weil D, Blanchard S, Kaplan J, Guilford P, Gibson F, Walsh J, Mburu P, Varela A, Leveilliers J, Weston MD, Kelly PM, Kimberling WJ, Wagenaar M, Levi-Acobas F, Larget-Piet D, Munnich A, Steel KP, Brown SD, Petit C Defective myosin VIIa responsible for Usher syndrome type IB Nature 1995 ;374 60-61.
- 34 Verpy E, Leitovici M, Zwaenepoel I, Liu XZ, Gal A, Salem N, Mansour A, Blanchard S, Kobayashi I, Keats BJ, Slim R, Petit C A defect in harmonin, a PDZ domain-containing protein expressed in the inner ear sensory hair cells, underlies Usher syndrome type 1C. Nat Genet 2000,26 51-55
- 35 Bitner-Glindzicz M, Lindley KJ, Rutland P, Blyden D, Smith VV, Milla PJ, Hussain K, Furth-Lavi J, Cosgrove KE, Shepherd RM, Barnes PD, O'Brien RE, Farndon PA, Sowden J, Liu XZ, Scanlan MJ, Malcolm S, Dunne MJ, Aynsley-Green A, Glaser B A recessive contiguous gene deletion causing infantile hyperinsulinism, enteropathy and deafness identifies the Usher type 1C gene Nat Genet 2000,26 56-60.
- 36 Bork JM, Peters LM, Riazuddin S, Bernstein SL, Ahmed ZM, Ness SL, Polomeno R, Ramesh A, Schloss M, Srisailpathy CR, Wayne S, Bellman S, Desmukh D, Ahmed Z, Khan SN, Kaloustian VM, Li XC, Lalwani A, Riazuddin S, Bitner-Glindzicz M, Nance WE, Liu XZ, Wistow G, Smith RJ, Griffith AJ, Wilcox ER, Friedman TB, Morell RJ Usher syndrome 1D and nonsyndromic autosomal recessive deafness DFNB12 are caused by allelic mutations of the novel cadherin-like gene CDH23 Am J Hum Genet 2001,68:26-37.
- 37 Bolz H, von Brederlow B, Ramirez A, Bryda EC, Kutsche K, Nothwang HG, Seeliger M, del C-Salcedo Cabrera M, Vila MC, Molina OP, Gal A, Kubisch C. Mutation of CDH23, encoding a new member of the cadherin gene family, causes Usher syndrome type 1D Nat Genet 2001,27 108-112
- 38 Chaib H, Kaplan J, Gerber S, Vincent C, Ayadi H, Slim R, Munnich A, Weissenbach J, Petit C. A newly identified locus for Usher syndrome type I, USH1E, maps to chromosome 21q21. Hum Mol Genet 1997;6 27-31
- 39 Ahmed ZM, Riazuddin S, Bernstein SL, Ahmed Z, Khan S, Griffith AJ, Morell RJ, Friedman TB, Riazuddin S, Wilcox ER Mutations of the protocadherin gene PCDH15 cause Usher syndrome type 1F Am J Hum Genet 2001;69 25-34.

- 40 Alagramam KN, Yuan H, Kuehn MH, Murcia CL, Wayne S, Srisailpathy CR, Lowry RB, Knaus R, Van Laer L, Bernier FP, Schwartz S, Lee C, Morton CC, Mullins RF, Ramesh A, Van Camp G, Hageman GS, Woychik RP, Smuth RJ, Hageman GS Mutations in the novel protocadherin PCDH15 cause Usher syndrome type 1F *Hum Mol Genet* 2001;10:1709-1718
- 41 Weil D, El-Amraoui A, Masmoudi S, Mustapha M, Kikkawa Y, Laine S, Delmaghani S, Adato A, Nadifi S, Zina ZB, Hamel C, Gal A, Ayadi H, Yonekawa H, Petit C. Usher syndrome type I G (USH1G) is caused by mutations in the gene encoding SANS, a protein that associates with the USH1C protein, harmonin *Hum Mol Genet* 2003;12 463-471
- 42 Eudy JD, Weston MD, Yao S, Hoover DM, Rehm HL, Ma-Edmonds M, Yan D, Ahmad I, Cheng JJ, Ayuso C, Cremers C, Davenport S, Moller C, Talmadge CB, Beisel KW, Tamayo M, Morton CC, Swaroop A, Kimberling WJ, Sumegi J Mutation of a gene encoding a protein with extracellular matrix motifs in Usher syndrome type IIa. *Science* 1998;280:1753-1757
- 43 Hmani M, Ghorbel A, Boulila-Elgaied A, Ben Zina Z, Kammoun W, Drira M, Chaabouni M, Petit C, Ayadi H A novel locus for Usher syndrome type II, USH2B, maps to chromosome 3 at p23-24 *Eur J Hum Genet* 1999;7:363-367
- 44 Pieke-Dahl S, Möller CG, Kelley PM, Astuto LM, Cremers CWRJ, Gorin MB, Kimberling WJ Genetic heterogeneity of Usher syndrome type II: localisation to chromosome 5q *J Med Genet* 2000;37 256-262.
- 45 Joensuu T, Hamalainen R, Yuan B, Johnson C, Tegelberg S, Gasparini P, Zelante L, Pirvola U, Pakarinen L, Lehesjoki AE, de la Chapelle A, Sankila EM Mutations in a novel gene with transmembrane domains underlie Usher syndrome type 3 *Am J Hum Genet* 2001;69:673-684.
- 46 Ahmed ZM, Riazuddin S, Riazuddin S, Wilcox ER The molecular genetics of Usher syndrome *Clin Genet* 2003;63:431-444.
- 47 Petit C. Usher syndrome from genetics to pathogenesis. *Annu Rev Genomics Hum Genet* 2001;2:271-297
- 48 Kimberling WJ. Clinical and genetic heterogeneity of Usher syndrome *Audiol Med* 2003;1:67-70.
- 49 El-Amraoui A, Petit C. Review paper. towards a molecular understanding of the pathophysiology of Usher syndrome. *J Audiol Med* 1997;6:170-184.
- 50 Tamagawa Y, Ishikawa K, Ishikawa K, Ishida T, Kitamura K, Makino S, Tsuru T, Ichimura K. Phenotype of DFNA11. a nonsyndromic hearing loss caused by a myosin VIIA mutation. *Laryngoscope* 2002;112:292-297.
- 51 Weil D, Kussel P, Blanchard S, Levy G, Levi-Acobas F, Drira M, Ayadi H, Petit C. The autosomal recessive isolated deafness, DFNB2, and the Usher 1B syndrome are allelic defects of the myosin VIIA gene *Nat Genet* 1997;16 191-193.
- 52 Ouyang XM, Xia XJ, Verpy E, Du LL, Pandya A, Petit C, Balkany T, Nance WE, Liu XZ. Mutations in the alternatively spliced exons of USH1C cause non-syndromic recessive deafness *Hum Genet* 2002;111:26-30
- 53 Rivolta C, Sweklo EA, Berson EL, Dryja TP Missense mutation in the *USH2A* gene: association with recessive retinitis pigmentosa without hearing loss *Am J Hum Genet* 2000;66 1975-1978
- 54 Saeed SR, Ramsden RT, Axon PR. Cochlear implantation in the deaf-blind. *Am J Otol* 1998;19 774-777
- 55 Hunderink JB, Broxk JPL, Mens LHM, van den Broek P Results from four cochlear implant patients with Usher's syndrome *Ann Otol Rhinol Laryngol* 1997;103:285-293.
- 56 Loundon N, Marlin S, Busquet D, Denoyelle F, Roger G, Renaud F, Garabedian EN. Usher syndrome and cochlear implantation *Otol Neurotol* 2003;24 216-221.
- 57 Wagenaar M, Draaijer P, Meek J, ten Donkelaar H, Wesseling P, Cremers CWRJ. The cochlear nuclei in two patients with Usher syndrome type I. *Int J Pediatr Otolaryngol* 1999;50 185-195
- 58 Pennings RJE, Huygen PLM, Weston MD, van Aarem A, Wagenaar M, Kimberling WJ, Cremers CWRJ Pure tone hearing thresholds and speech recognition scores in Dutch patients carrying mutations in the *USH2A* gene. *Otol Neurotol* 2003;24:58-63.
- 59 Wagenaar M, van Aarem A, Huygen PLM, Pieke-Dahl S, Kimberling WJ, Cremers CWRJ Hearing impairment related to age in Usher syndrome type 1B and 2A; hearing impairment in *USH2A* is progressive. *Arch Otolaryngol Head Neck Surg* 1999;125 441-445
- 60 van Aarem A, Huygen PLM, Pinckers AJLG, Bleeker-Wagemakers EM, Kimberling WJ, Cremers CWRJ Stable and progressive hearing loss in type 2A Usher syndrome. *Ann Otol Rhinol Laryngol* 1996;105:962-967.
- 61 Hmani-Aifa M, Ben Arab S, Kharrat K, Orten DJ, Boulila-Elgaied A, Drira M, Hachicha S, Kimberling WJ, Ayadi H. Distinctive audiometric features between USH2A and USH2B subtypes of Usher syndrome *J Med Genet* 2002;39:281-283
- 62 Pakarinen L, Karjalainen S, Simola KOJ, Lauppala P, Kaitalo H. Usher's syndrome type 3 in Finland. *Laryngoscope* 1995;105:603-617.

- 63 Karjalainen S, Pakarinen L, Teräsvirta M, Kaariainen H, Vartiainen E. Progressive hearing loss in Usher's syndrome. *Ann Otol Rhinol Laryngol* 1989;98:863-866.
- 64 Pakarinen L, Sankila E-M, Tuppurainen K, Karjalainen S, Kääriäinen H. Usher syndrome type III (USH3): the clinical manifestations in 42 patients. *Scand J Logoped Phoniat* 1995;20 141-150.
- 65 Sankila E-M, Pakarinen L, Kaariainen H, Aittomäki K, Karjalainen S, Sistonen P, de la Chapelle A. Assignment of an Usher syndrome type III (USH3) gene to chromosome 3q. *Hum Mol Genet* 1995;4:93-98.
- 66 Joensuu T, Hamalainen R, Yuan B, Johnson C, Tegelberg S, Gasparini P, Zelante L, Pirvola U, Pakarinen L, Lehesjoki A-E, de la Chapelle A, Sankila E-M. Mutations in a novel gene with transmembrane domains underlie Usher syndrome type 3. *Am J Hum Genet* 2001;69 673-684.
- 67 Pennings RJE, Fields RR, Huygen PLM, Deutman AF, Kimberling WJ, Cremers CWRJ. Usher syndrome type III can mimic other types of Usher syndrome. *Ann Otol Rhinol Laryngol* 2003;112 525-530
- 68 Pagon RA. Retinitis pigmentosa. *Surv Ophthalmol* 1988;33 137-177
- 69 Kaplan J, Bonneau D, Frezal J, Munnich A, Dufier JL. Clinical and genetic heterogeneity in retinitis pigmentosa. *Hum Genet* 1990;85:635-642
- 70 van Aarem A, Wagenaar M, Pinckers AJLG, Huygen PLM, Bleeker-Wagemakers EM, Kimberling WJ, Cremers CWRJ. Ophthalmologic findings in Usher syndrome type 2A. *Ophthalmic Genet* 1995;16:151-158.
- 71 Pennings RJE, te Brinke H, Weston MD, Claassen A, Orten DJ, Weekamp H, van Aarem A, Wagenaar M, Huygen PLM, Deutman AF, Hoefsloot LH, Cremers FPM, Cremers CWRJ, Kimberling WJ, Kremer H. *USH2A* Mutation analysis in 70 Dutch families with Usher syndrome. *Hum Mutat* 2004 conditionally accepted
- 72 Cremers CWRJ. *Hereditaire aspecten van vroeg kinderlijke doofheid*. Thesis Katholieke Universiteit Nijmegen, 1976
- 73 Young NM, Mets MB, Hain TC. Early diagnosis of Usher syndrome in infants and children. *Am J Otol* 1996;17:30-34
- 74 Vernon M. Usher's syndrome: deafness and progressive blindness. Clinical cases, prevention, theory and literature survey. *J Chron Dis* 1969;22 133-151
- 75 Fishman GA, Kumar A, Joseph ME, Torok N, Anderson RJ. Usher's syndrome. Ophthalmic and neuro-otologic findings suggesting genetic heterogeneity. *Arch Ophthalmol* 1983;101 1367-1374.
- 76 Piazza L, Fishman GA, Farber M, Derlacki D, Anderson RJ. Visual acuity loss in patients with Usher's syndrome. *Arch Ophthalmol* 1986;104:1336-1339
- 77 Edwards A, Fishman GA, Anderson RJ, Grover S, Derlacki DJ. Visual acuity and visual field impairment in Usher syndrome. *Arch Ophthalmol* 1998;116:165-168
- 78 Wagenaar M. *The Usher syndrome. A clinical and genetic correlation*. Thesis Katholieke Universiteit Nijmegen, 2000
- 79 Seeliger M, Pfister M, Gendo K, Paasch S, Apfelstedt-Sylla E, Plinkert P, Zenner H-P, Zrenner E. Comparative study of visual, auditory and olfactory function in Usher syndrome. Graefe's *Arch Clin Exp Ophthalmol* 1999;237:301-307
- 80 Tsilou ET, Rubin BI, Caruso RC, Reed GF, Pikus A, Hejtmancik JF, Iwata F, Redman JB, Kaiser-Kupfer MI. Usher syndrome clinical types I and II: Could ocular symptoms and signs differentiate between the two types? *Acta Ophthalmol Scand* 2002;80 196-201
- 81 Pennings RJE, Huygen PLM, Orten DJ, Wagenaar M, van Aarem A, Kremer H, Kimberling WJ, Cremers CWRJ, Deutman AF. Evaluation of visual impairment in Usher syndrome Ib and Usher syndrome IIa. *Acta Ophthalmol Scand* 2004 in press.
- 82 Pakarinen L, Tuppurainen K, Laippal P, Mantyjärvi M, Puhakka H. The ophthalmological course of Usher syndrome type III. *Int Ophthalmol* 1996;19:307-311.
- 83 Sun JC, van Alphen AM, Wagenaar M, Huygen P, Hoogenraad CC, Hasson T, Koekkoek SKE, Bohne BA, De Zeeuw CI. Origin of vestibular dysfunction in Usher syndrome type 1B. *Neurobiol Dis* 2001;8 69-77
- 84 Sun JC, van Alphen AM, Wagenaar M, Huygen P, Hoogenraad CC, Hasson T, Koekkoek SKE, Bohne BA, De Zeeuw CI. Hereditary familial vestibular degenerative diseases. *Ann NY Acad Sci* 2001;942 493-496.
- 85 Sun JC, van Alphen AM, Bohne BA, De Zeeuw CI. Shaker-1 mice show an optokinetic reflex but no vestibulo-ocular reflex. *Ann NY Acad Sci* 2001;942:492
- 86 Huygen PLM, Pennings RJE, Nicolassen MGM, Verhagen WIM, Kimberling WJ, Kremer H, Verhagen WIM, Deutman AF, Cremers CWRJ. Analysis of optokinetic and vestibular responses related to advancing age and increasing visual impairment in Usher syndrome type IIa. *Exp Brain Res* 2004 submitted.



- 87 Otterstedde CR, Spandau U, Blankenagel A, Kimberling WJ, Reisser C. A new clinical classification for Usher's syndrome based on a new subtype of Usher syndrome type I. *Laryngoscope* 2001;111:84-86

1.2

---

WOLFRAM SYNDROME



---

## HISTORICAL PERSPECTIVE OF WOLFRAM SYNDROME

In 1938, Wolfram and Wagener reported on a family with 6 children, 4 of them having the combination of diabetes mellitus and optic atrophy<sup>1</sup> In 3 sibs the diabetes mellitus preceded the optic atrophy, however, the youngest sib first presented with optic atrophy On the basis of these findings they concluded that the optic atrophy could not have been caused by the disturbance of the sugar metabolism This was the first publication that reported on the association of diabetes mellitus and progressive optic atrophy Several years later, Tunbridge (1956) reported on a personal communication with Wagener that three of the sibs reported on in 1938 also had subnormal hearing as tested by watch ticks Two of the children were re-examined and their optic atrophy had progressed to complete blindness Wagener also stated that two sibs had developed a cord bladder<sup>2</sup> In the next decades, many case reports on similar patients were published and over the years it became apparent that the combination of diabetes mellitus, optic atrophy, diabetes insipidus and sensorineural HI was one that belonged to a rare syndrome In 1977, Cremers et al<sup>3</sup> described 3 additional cases from the Netherlands and presented a review of 88 cases described in the international literature In this publication, the syndromic association was referred to as Wolfram syndrome, to acknowledge the original publication in 1938<sup>3</sup> Another important study on Wolfram syndrome was performed by Barrett et al in 1995<sup>4</sup> They performed a UK nationwide study and included 45 patients with Wolfram syndrome, which illustrates the rarity of the syndrome In the next paragraphs, the clinical and genetic features of Wolfram syndrome will be outlined

## CLINICAL CHARACTERISTICS OF WOLFRAM SYNDROME

Wolfram syndrome is also known by the acronym DIDMOAD, which stands for Dibetes Insipidus, Dibetes Mellitus, Optic Atrophy and Deafness It shows autosomal recessive inheritance and is rare, with an estimated general prevalence of 1 in 770,000 in the UK<sup>4</sup> The syndrome is caused by mutations in the *WFS1* gene,<sup>5,6</sup> which encodes wolframin

*Diabetes mellitus*

Diabetes mellitus has a median age of presentation of 6 years and is non-autoimmune, insulin-deficient and non-HLA linked<sup>3,4</sup> Remarkably, Wolfram syndrome patients seem relatively resistant to microvascular complications<sup>7</sup> The reason for this is unclear, however, a hypothesis is that the decreased levels of sex steroid hormones in these patients protect against diabetic retinopathy by decreasing vascular permeability<sup>8</sup> Although the diabetes mellitus presents in an atypical fashion, it is clearly related to the loss of  $\beta$ -cells in the islets of Langerhans in the pancreas, which results in reduced production of insulin<sup>9</sup> In addition, it has recently been shown that wolframín is required to maintain normal rates of  $\beta$ -cell proliferation<sup>10</sup>

*Optic atrophy*

Progressive optic atrophy presents with reduced visual acuity and loss of colour vision (blue-yellow) at a median age of 11 years<sup>3,4</sup> At about 18-19 years, optic atrophy in most cases has progressed to complete blindness<sup>4,8,11</sup> In Wolfram syndrome, optic atrophy is not secondary to retinal pathology It is part of a more generalised degeneration of neural structures<sup>8,12</sup> In addition to optic atrophy, in about 65% cataract is found, however, this is only mild and not contributing to the loss of vision<sup>13</sup> Pathology examinations have revealed atrophy not only of the optic nerve, but of the entire visual pathway with degeneration of retinal ganglion cells, loss of nerve fibers in the optic nerves, optic chiasm and central optic tracts<sup>14</sup>

*Diabetes insipidus*

Diabetes insipidus in Wolfram syndrome patients is of hypothalamic origin and responds to vasopressin treatment It manifests in about 75% of the patients in the second decade of life at a median age of 14 years<sup>3,4</sup> Polyuria is often presumed to be secondary to diabetic hyperglycemia and it therefore may take long before the actual diagnosis is made<sup>4</sup> In addition, atony of the urinary tract may be suggestive for the presence of renal diabetes insipidus, which may obscure the hypothalamic origin<sup>15</sup> Some studies suggest that hypothalamic diabetes insipidus occurs in nearly all Wolfram syndrome patients<sup>16</sup> On postmortem examination, the hypothalamus shows loss of vasopressin neurons in the supraoptic and paraventricular nuclei<sup>12</sup> However, not only loss of vasopressin neurons occurs in

Wolfram syndrome but in another Dutch study it was shown that there is also a defect in vasopressin precursor processing.<sup>17</sup>

### *Deafness - Hearing impairment*

HI is estimated to occur in 51-62% of the Wolfram syndrome patients.<sup>4,7,18</sup> It manifests mostly in the second decade of life at a median age of 15-16 years.<sup>3,4</sup> The hearing loss is most prominent in the high-frequency range, however, in case of progressive HI the low frequencies also tend to be affected.<sup>3,19</sup> Ohata et al. reported an increased risk for hearing loss in heterozygous carriers of *WFS1* mutations in a Wolfram syndrome family.<sup>20</sup> However, in their study the type of HI was not described and thus it cannot be determined whether or not it was similar to DFNA6/14, a low-frequency type of HI, which is caused by heterozygous mutations in the *WFS1* gene.<sup>21-22</sup> In Chapter 4.1 of this thesis, the results of audiovestibular examinations in 11 Wolfram syndrome patients from the Netherlands are presented.<sup>23</sup> The audiovestibular examination results of 2 Dutch DFNA6/14 families are described in Chapter 5.1 of this thesis and are briefly mentioned in the review in the last section of this introduction.<sup>24,25</sup>

### *Urological abnormalities*

Dilatation of the urinary tract is a common feature in Wolfram syndrome. Although it is not covered by the acronym DIDMOAD, it manifests mainly in the second decade in 52-58% of the Wolfram syndrome patients.<sup>3,4,18</sup> The median onset age is 15-20 years.<sup>4,18</sup> Patients often complain about incontinence and a high urinary frequency, which may be caused by the hypothalamic diabetes insipidus and/or a poorly managed diabetes mellitus.<sup>4</sup> Hydronephrosis and/or hydroureters are present in about 75% of the Wolfram syndrome patients with urinary anomalies.<sup>18,26</sup> It has been hypothesised that hydronephrosis may be caused by the high urine output, however, Tekgül et al. reported that severe hydronephrosis did not improve on desmopressin therapy. Bladder dysfunction in Wolfram syndrome presents in a wide spectrum, with a large atonic bladder and a low-capacity, high-pressure bladder with sphincteric dyssynergia as the most common manifestations. Therefore, bladder dysfunction is thought to be a primary feature of the syndrome instead of a secondary feature.<sup>26</sup>

### *Neuropsychiatric abnormalities*

Central nervous system abnormalities are found in Wolfram syndrome patients with a median age of onset at 30 years<sup>4</sup> There is much variability in the presentation of these abnormalities Truncal ataxia, which causes unsteady gait and falling, is the most common finding and is seen in approximately 30% of the patients<sup>4 18</sup> Another common finding is central respiratory dysfunction and apnea, which is the cause of death in 39% of the cases in one report<sup>9 18</sup> Additional neurological features reported in Wolfram syndrome include seizures, startle myoclonus, reduced limb reflexes, nystagmus, dysarthria, anosmia, ageusia and hemiparesis, peripheral neuropathy and developmental disabilities<sup>9 27</sup> The variety of neurological abnormalities reflects the underlying neurodegeneration, which can manifest anywhere in the central nervous system Magnetic resonance imaging studies of Wolfram syndrome patients have shown widespread neurodegeneration<sup>28 29</sup> Also in postmortem examinations of Wolfram syndrome patients, neurodegeneration of many regions of the brain and widespread axonal pathology that parallels the neurodegeneration is a common finding<sup>14 30</sup>

Neurodegeneration may also be involved in the psychiatric features of Wolfram syndrome In about 60% of reviewed cases in the USA, psychiatric findings were reported and consisted of episodes of severe depression, psychosis or organic brain syndrome, as well as impulsive verbal and physical aggression In 25% of these cases the psychiatric symptoms were very severe and in 18% admission to a psychiatric hospital was required<sup>31</sup> Mental illness is not only common in Wolfram syndrome patients but also their mutation-carrying relatives may be affected The prevalence of mental illness in heterozygous carriers of *WFS1* mutations is 26-fold higher than in non-carriers<sup>32 33</sup>

### *Hypogonadism*

Hypogonadism is a frequent finding in male Wolfram syndrome patients<sup>27</sup> The relative prevalence of hypogonadism in male Wolfram syndrome patients varies from 33-70%<sup>4 18 34</sup> Most of the affected men have small, soft atrophic testes and histopathology studies have shown evidence of fibrosis and tubular atrophy<sup>18</sup> Most patients have reduced fertility, however, several female patients had successful pregnancies and gave birth to healthy unaffected children<sup>18 35</sup> Hypogonadism in Wolfram syndrome has been attributed to hypothalamic dysfunction with correspondingly low or normal gonadotropin levels<sup>36</sup> However,

more recent studies have suggested that hypogonadism is merely caused by primary gonadal atrophy and not by hypothalamic dysfunction.<sup>4,11,18,27,37</sup>

#### *Other clinical manifestations*

Several case reports have shown that Wolfram syndrome patients may also develop cardiac abnormalities. Features include Fallot's tetralogy, pulmonary valve stenosis, sinus tachycardia and atrial and ventricular arrhythmias.<sup>18</sup> Anosmia is a relatively frequent finding in Wolfram syndrome patients and occurs in about 9% of the patients.<sup>18</sup> Autopsy findings have shown that the underlying cause is atrophy of the olfactory bulbs and tracts.<sup>14</sup> Gastrointestinal motility disturbances have been reported in about 24% of the Wolfram syndrome patients. Symptoms include constipation with faecal impaction as well as chronic diarrhoea.<sup>4</sup> Hypothyroidism is also reported in several Wolfram syndrome patients, however, it does not appear to be a frequent finding.<sup>38</sup>

#### *Mortality*

The median age at death is estimated to be 30 years (25-49 years).<sup>4</sup> Causes of death include central respiratory failure, renal failure secondary to infection, hypoglycaemic coma, pneumonia, status epilepticus, suicide related to psychiatric disease, or death related to severely advanced neurodegeneration.<sup>4,11,18</sup>

## GENETIC CHARACTERISTICS OF WOLFRAM SYNDROME

In the early nineties of the past century, it has been hypothesised that mitochondrial deletions and/or mutations were responsible for Wolfram syndrome (OMIM 222300). This was based on the similarity of Wolfram syndrome features to symptoms due to mitochondrial mutations including deafness, diabetes mellitus, optic atrophy, psychiatric disorders and thrombocytopenia.<sup>39-44</sup> Several studies have identified abnormalities in the mitochondrial genome in patients with Wolfram syndrome. Rötig et al.<sup>45</sup> found a deletion of mitochondrial DNA in a patient, diagnosed with Wolfram syndrome. However, this patient in addition developed a failure to thrive, cerebellar ataxia, nightblindness, progressive external ophthalmoplegia, an extrapyramidal syndrome and mental retardation. At 13 years of age, she had severe amyotrophy, inability to stand and



walk, RP and major difficulty in swallowing. These symptoms were caused by a 7670 bp deletion in the mitochondrial genome and skipped the genes *COX1*, *COX2*, *ATPase6*, *ATPase8*, *COX3*, *ND3*, *ND4L*, *ND4* and part of *ND5*.<sup>45</sup> A study by Barrientos et al.<sup>46</sup> demonstrated a heteroplasmic mitochondrial DNA deletion of 8.5 kb in 23% of the copies of the mitochondrial DNA in lymphocytes and about 5% in tissues studied from relatives. The patient was diagnosed with Wolfram syndrome on the basis of the presence of the four main symptoms. The authors suggested that Wolfram syndrome in this family was caused by a nuclear genetic defect inherited in an autosomal recessive mode that predisposes to a mitochondrial DNA deletion, which may contribute to the clinical manifestations in the homozygous individual.<sup>46</sup> To explain the mitochondrial genomic deletions, which show maternal inheritance in an autosomal recessively inherited syndrome, Bu & Rotter hypothesised a dual genome defect model.<sup>47</sup> As Wolfram syndrome shows autosomal recessive inheritance and most of the clinical features seem to relate to an ATP supply defect often seen in mitochondrial disorders, they proposed that nuclear genetic defects or mitochondrial genetic defects can independently lead to the same disorder.<sup>47</sup>

In 1998, after linkage of the critical region to chromosome 4p16.1,<sup>48,49</sup> two groups reported cloning of the Wolfram syndrome 1 gene (*WFS1*).<sup>5,6</sup> In a more recent study by Barrett et al.<sup>50</sup>, the mitochondrial genome was evaluated in a large patient group but no mtDNA mutations or abnormal mitochondrial function were found. In 16 of 17 examined families loss of functions mutations in the *WFS1* gene were identified.<sup>50</sup> The *WFS1* gene consists of 8 exons encompassing 33.4 kb of genomic DNA and encodes wolframin consisting of 890 amino acids with an apparent molecular weight of 100 kD. Wolframin is a transmembrane protein with nine transmembrane domains.<sup>48,49</sup> Several studies of large patient groups have identified many mutations in *WFS1*. Until recently, no real mutational hotspot or clustering of mutations were observed.<sup>51-54</sup> However, in a Spanish cohort of 12 different Wolfram syndrome families, an insertion of 16 base pairs in exon 4 was found to cause the disease in 6 families.<sup>55</sup> Mutation analysis of the *WFS1* gene identifies mutations in about 90% of the patients.<sup>54</sup> Most of the identified mutations are inactivating or truncating mutations, which suggests that loss of wolframin function is the main cause of the disease.<sup>56</sup> Only a few patients were reported to have homozygous or compound heterozygous missense mutations in *WFS1*. Remarkably, these patients have optic atrophy, diabetes mellitus and in some cases HI, however, diabetes insipidus and other Wolfram symptoms are

lacking.<sup>51,56</sup> In our clinical study of Wolfram syndrome patients, 2 sisters were described with compound heterozygous missense mutations in *WFS1* and mild features of Wolfram syndrome.<sup>23,52</sup> It therefore seems possible that missense mutations in the *WFS1* gene cause a mild variant of Wolfram syndrome, however, patients with a homozygous missense mutation in *WFS1* and a more severe phenotype have also been reported.<sup>57</sup>

In 2000, El-Shanti et al.<sup>58</sup> examined 16 Wolfram syndrome patients from 4 different families and found that 3 families were not linked to the *WFS1* locus, but to a second locus, designated *WFS2* on chromosome 4q22-24. These patients have a Wolfram syndrome-like phenotype without evidence of diabetes insipidus but with profound upper gastrointestinal tract ulceration and bleeding.<sup>58</sup> A prolonged bleeding time due to abnormal platelet aggregation was found in these patients.<sup>59</sup>

Several studies focused on a possible role of the *WFS1* gene in diabetes mellitus or psychiatric disorders. Two studies have shown that sequence variants in *WFS1* may be involved in the pathogenesis of type 2 diabetes mellitus in patients from the UK and Spain.<sup>60,61</sup> Awata et al.<sup>62</sup> have shown that especially R456H and the single nucleotide polymorphisms H611R and I720V are significantly correlated with type I diabetes mellitus.<sup>62</sup> However, whether these sequence variants in *WFS1* really cause type I or II diabetes mellitus, still remains to be elucidated.<sup>56</sup> Following the report that Wolfram syndrome heterozygotes are 26-fold more likely to require psychiatric hospitalisation when compared to non-carriers and the fact that Wolfram syndrome heterozygotes may constitute approximately 25% of individuals hospitalised with depression and suicide attempts,<sup>31,63</sup> some studies examined whether or not wolframin plays a major role in affective disorders. Several studies have shown that rare coding variants in exon 8 of the *WFS1* gene may be potential risk alleles for psychiatric disease.<sup>55,56,64-67</sup> However, it is still not possible to draw firm conclusions on the basis of these results, because of the very low frequencies of these variants.<sup>56</sup>

In 2001, two different research groups identified mutations in the *WFS1* gene as the cause of a nonsyndromic autosomal dominantly inherited type of low-frequency HI, named DFNA6/14.<sup>21,22</sup> Mutation analysis of *WFS1* in patients with low-frequency sensorineural HI revealed heterozygous mutations in most patients. Thus, mutations in this gene are a major cause of low-frequency HI.<sup>68</sup> So far, there is still no explanation as to why the HI in DFNA6/14 merely affects the

low frequencies and in Wolfram syndrome the high frequencies. In addition, the mutations responsible for DFNA6/14 seem to be non-inactivating mutations, which are located in the C-terminal domain of the protein.<sup>68</sup>

At this moment, only little is known about the function of wolframin. Takeda et al.<sup>69</sup> showed that it has a predominant subcellular localization to the endoplasmic reticulum in cultured cells and has neuronal expression in rat brain tissue. No colocalization of wolframin with mitochondria was seen. In rat brain, wolframin was found to be predominantly present in specific neurons in the hippocampus CA1, amygdaloid areas, olfactory tubercle and the superficial layer of the allocortex. These sites of expression may be involved in the psychiatric, behavioural and emotional abnormalities characteristic of this syndrome. It was hypothesised that wolframin plays a role in membrane trafficking, protein processing or calcium homeostasis in the endoplasmic reticulum.<sup>69</sup> In the inner ear, wolframin is expressed in the canalicular reticulum, a specialised form of the endoplasmic reticulum, which is believed to be involved in the transcellular movements of ions. For this reason, Cryns et al. suggested that wolframin plays a role in inner ear ion homeostasis maintained by the canalicular reticulum.<sup>70</sup>

## REFERENCES

- 1 Wolfram DJ, Wagener HP Diabetes mellitus and simple optic atrophy among siblings report of four cases Proc Mayo Clin 1938;13 715-718.
- 2 Tunbridge RE, Paley RG Primary optic atrophy in diabetes mellitus Diabetes, 1956;5 295-296
- 3 Cremers CWRJ, Wijdeveld PGAB, Pinckers AJLG Juvenile diabetes mellitus, optic atrophy, hearing loss, diabetes insipidus, atonia of the urinary tract and bladder, and other abnormalities (Wolfram syndrome) A review of 88 cases from the literature with personal observations on 3 new patients Acta Paediatr Scand Suppl 1977;(264) 1-16
- 4 Barrett TG, Bunday SE, McLeod AF Neurodegeneration and diabetes UK nationwide study of Wolfram (DIDMOAD) syndrome Lancet 1995;346 1458-1463.
- 5 Inoue H, Taruzawa Y, Wasson J, Behn P, Kalidas K, Bernal-Mizrachi E, Mueckler M, Marshall H, Donis-Keller H, Crock P, Rogers D, Mikuni M, Kumashiro H, Highashi K, Sobue G, Oka Y, Permutt MA. A gene encoding a transmembrane protein is mutated in patients with diabetes mellitus and optic atrophy (Wolfram syndrome) Nat Genet 1998;20 143-148
- 6 Strom TM, Hörtnagel K, Hofmann S, Gekeler F, Scharfe C, Rabl W, Gerbitz K, Meitinger T Diabetes insipidus, diabetes mellitus, optic atrophy and deafness (DIDMOAD) caused by mutations in a novel gene (*wolframin*) coding for a predicted transmembrane protein Hum Mol Genet 1998;7 2021-2028.
- 7 Blasí C, Pierelli F, Rispoli E, Saponara M, Vingolo E, Andreani D Wolfram's syndrome: a clinical, diagnostic, and interpretative contribution. Diabetes Care 1986;9:521-528
- 8 Barrett TG, Bunday SE, Fielder AR, Good PA Optic atrophy in Wolfram (DIDMOAD) syndrome. Eye 1997;11:882-888
- 9 Karasik A, O'Hara C, Srikanta S, Swift M, Soeldner JS, Kahn CR, Herskowitz RD Genetically programmed selective islet beta-cell loss in diabetic subjects with Wolfram's syndrome Diabetes Care 1989;12:135-138

- 10 McBain SC, Morgan NG Functional effects of wolframun-antisense transcripts in BRIN-BD11 beta-cells Biochem Biophys Res Commun 2003;307:684-688.
- 11 Barrett TG, Bunday SE Wolfram (DIDMOAD) syndrome J Med Genet 1997;34 838-841
- 12 Mtanda AT, Cruysberg JRM, Pinckers AJLG. Optic atrophy in Wolfram syndrome. Ophthal Paediatr Genet 1986;7 159-165.
- 13 Al-Till M, Jarrah NS, Ajlouni KM. Ophthalmologic findings in fifteen patients with Wolfram syndrome Eur J Ophthalmol 2002;12:84-88.
- 14 Genis D, Davalos A, Molins A, Ferrer I Wolfram syndrome: a neuropathological study Acta Neuropathol (Berl) 1997;93:426-429.
- 15 van der Korst JK Diurese en natriurese bij diabetes insipidus. De invloed van de zout (natriumchloride)-opneming en het effect van de chlorothiazidederivaten Thesis Katholieke Universiteit Nijmegen, 1965
- 16 Thompson CJ, Charlton J, Walford S, Baird J, Hearnshaw J, McCulloch A, Kelly W, Baylis PH Vasopressin secretion in the DIDMOAD (Wolfram) syndrome Q J Med 1989;71 333-345.
- 17 Gabreeÿs BATHF, Swaab DF, de Kleijn DPV, Dean A, Seidah NG, van de Ven WJM, Martens GJM, van Leeuwen FW. The vasopressin precursor is not processed in the hypothalamus of Wolfram syndrome patients with diabetes insipidus: evidence for the involvement of PC2 and 7B2 J Clin Endocrinol Metab 1998;83:4026-4033
- 18 Kinsley BT, Swift M, Dumont RH, Swift RG Morbidity and mortality in the Wolfram syndrome. Diabetes Care 1995;18 1566-1570.
- 19 Higashi K. Otologic findings of DIDMOAD syndrome. Am J Otol 1991;12 57-60
- 20 Ohata T, Koizumi A, Kayo T, Shoji Y, Watanabe A, Monoh K, Higashi K, Ito S, Ogawa O, Wada Y, Takada G. Evidence of an increased risk of hearing loss in heterozygous carriers in a Wolfram syndrome family. Hum Genet 1998;103:470-474.
- 21 Bespalova IN, Van Camp G, Bom SJH, Brown DJ, Cryns K, DeWan AT, Erson AE, Flothmann K, Kunst HPM, Kurnool P, Sivakumaran TA, Cremers CWRJ, Leal SM, Burmeister M, Lesperance MM Mutations in the Wolfram syndrome 1 gene (*WFS1*) are a common cause of low frequency sensorineural hearing loss Hum Mol Genet 2001;10:2501-2508
- 22 Young T-L, Ives E, Lynch E, Person R, Snook S, MacLaren L, Cator T, Griffin A, Fernandez B, Lee MK, King M-C. Non-syndromic progressive hearing loss *DFNA38* is caused by heterozygous missense mutation in the Wolfram syndrome gene *WFS1*. Hum Mol Genet 2001;10:2509-2514
- 23 Pennings RJE, Huygen PLM, van den Ouweland JMW, Cryns K, Dikkeschei LD, Van Camp G, Cremers CWRJ. Sex-related hearing impairment in Wolfram syndrome patients identified by inactivating *WFS1* mutations. Audiol Neurootol 2004;9:51-62.
- 24 Pennings RJE, Bom SJH, Cryns K, Flothmann K, Huygen PLM, Kremer H, Van Camp G, Cremers CWRJ. Low-frequency sensorineural hearing loss (*DFNA6/14/WFS1*) is progressive Arch Otolaryngol Head Neck Surg 2003;129:421-426
- 25 Pennings RJE, Huygen PLM, Van Camp G, Cremers CWRJ. A review of progressive phenotypes in nonsyndromic autosomal dominant hearing impairment. Audiol Med 2003;1:47-55.
- 26 Tekgl S, ge , ŐimŐek E, Yordam N, Kendi S Urological manifestations of the Wolfram syndrome observations in 14 patients. J Urol 1999;161 616-617
- 27 Fuqua JS Wolfram syndrome: clinical and genetic aspects The Endocrinologist 2000;10 51-59
- 28 Galluzzi P, Filosome G, Vallone IM, Bardelli AM, Venturi C MRI of Wolfram syndrome (DIDMOAD) Neuroradiology 1999;41:729-731.
- 29 Rando TA, Horton JC, Layzer RB. Wolfram syndrome. evidence of a diffuse neurodegenerative disease by magnetic resonance imaging Neurology 1992;42:1220-1224
- 30 Shannon P, Becker L, Deck J Evidence of widespread axonal pathology in Wolfram syndrome Acta Neuropathol 1999;98:304-308
- 31 Swift RG, Sadler DB, Swift M Psychiatric findings in Wolfram syndrome homozygotes Lancet 1990;336:667-669.
- 32 Swift RG, Perkins DO, Chase CL, Sadler DB, Swift M. Psychiatric disorders in 36 families with Wolfram syndrome. Am J Psychiatry 1991;148:775-779.
- 33 Swift M, Swift RG. Psychiatric disorders and mutations at the Wolfram syndrome locus Biol Psychiatry 2000;47:787-793.
- 34 ŐimŐek E, ŐimŐek T, Tekgl S, Hosal S, Seyrantepe V, Aktan G Wolfram (DIDMOAD) syndrome: a multidisciplinary clinical study in nine Turkish patients and review of the literature Acta Paediatr 2003;92:55-61
- 35 Davidson IR, McNicholl JM, O'Donnell J. Successful pregnancy in two sisters with Wolfram syndrome. Irish Med J 1993;86:33-34

- 36 Gunn T, Bortolussi R, Little JM, Andermann F, Fraser FC, Belmonte MM Juvenile diabetes mellitus, optic atrophy, sensory nerve deafness and diabetes insipidus. a syndrome. *J Pediatr* 1976;89:565-570.
- 37 Homan MR, Mackay BR Primary hypogonadism in two siblings with Wolfram syndrome *Diabetes Care* 1987;10:664-665.
- 38 Aboseif S, Gasparini M, Schmidt R, Tanagho E Wolfram's (DIDMOAD) syndrome and its urological manifestation *Br J Urol* 1993;72 106-111
- 39 Goto Y, Nonaka I, Horai S. A mutation in the tRNA Leu (UUR) gene associated with the MELAS subgroup of mitochondrial encephalopathies *Nature* 1990;348:651-653
- 40 van den Ouweland JMW, Lemkes HHP, Ruitenbeek W, Sandkuijl LA, de Vijlder MF, Struyvenberg PA, van de Kamp JJ. Mutation in mitochondrial tRNA<sup>LEU(UUR)</sup> gene in a large pedigree with maternally transmitted type II diabetes mellitus and deafness *Nat Genet* 1992;1:368-371
- 41 Norby S. Screening for the two most frequent mutations in Leber's hereditary optic neuropathy by duplex PCR based on allele specific amplification *Hum Mutat* 1993;2:309-313
- 42 Jackson MJ, Bindoff LA, Weber K, Wolson JN, Ince P, Alberti KG, Turnbull DM. Biochemical and molecular studies of mitochondrial function in diabetes insipidus, diabetes mellitus, optic atrophy and deafness *Diabetes Care* 1994;17 728-733
- 43 Poulton J, O'Rahilly S, Morten K, Clark A. Mitochondrial DNA, diabetes and pancreatic pathology in Kearns-Sayre syndrome *Diabetologia* 1995;38 868-871.
- 44 Gerbitz KD Reflexions on a newly discovered diabetogenic gene, Wolframin (WFS1). *Diabetologia* 1999;42:627-630
- 45 Rötig A, Cormier V, Chatelain P, Francois R, Saudubray J-M, Rustin P, Munnich A Deletion of mitochondrial DNA in a case of early-onset diabetes mellitus, optic atrophy and deafness (DIDMOAD, Wolfram syndrome). *J Inher Metab Dis* 1993;16:527-530
- 46 Barrientos A, Casademont J, Saiz A, Cardellach F, Volpini V, Solans A, Tolosa E, Urbano-Márquez A, estvill X, Nunes V Autosomal recessive Wolfram syndrome associated with an 8.5-kb mtDNA single deletion. *Am J Hum Genet* 1996;58:963-970
- 47 Bu X, Rotter JI. Wolfram syndrome: a mitochondrial-mediated disorder? *Lancet* 1993;342:598-600.
- 48 Collier DA, Barrett TG, Curtis D, MacLeod A, Arranz MJ, Maassen JA, Bunday S Linkage of Wolfram syndrome to chromosome 4p16.1 and evidence for heterogeneity *Am J Hum Genet* 1996;59:855-863
- 49 Polymeropoulos MH, Swift RG, Swift M. Linkage of the gene for Wolfram syndrome to markers on the short arm of chromosome 4 *Nat Genet* 1994;8:95-97
- 50 Barrett TG, Scott-Brown M, Seller A, Bednarz A, Poulton K, Poulton J The mitochondrial genome in Wolfram syndrome. *J Med Genet* 2000;37 463-466
- 51 Hardy C, Khanim F, Torres R, Scott-Brown M, Seller A, Poulton J, Collier D, Kirk J, Polymeropoulos M, Latif F, Barrett T. Clinical and molecular genetic analysis of 19 Wolfram syndrome kindreds demonstrating a wide spectrum of mutations in WFS1 *Am J Hum Genet* 1999;65 1279-1290.
- 52 van den Ouweland JWM, Cryns K, Pennings RJE, Walraven I, Janssen GMC, Maassen JA, Veldhuijzen BFE, Arntzenius AB, Lindhout D, Cremers CWRJ, Van Camp G, Dikkeschei LD Molecular characterization of WFS1 in patients with Wolfram syndrome. *J Mol Diagn* 2003;5 88-95
- 53 Eller P, Foger B, Gander R, Sauper T, Leichttner M, Finkenstedt G, Patsch JR. Wolfram syndrome. a clinical and molecular genetic analysis *J Med Genet* 2001;38 e37.
- 54 Khanim F, Kirk J, Latif F, Barrett TG. WFS1/Wolframin mutations, Wolfram syndrome, and associated diseases. *Hum Mutat* 2001;17:357-367.
- 55 Gomez-Zaera M, Strom T, Rodriguez B, Estvill X, Meitinger T, Nunes V. Presence of a major WFS1 mutation in Spanish Wolfram syndrome pedigrees *Mol Genet Metab* 2001;72:72-81
- 56 Cryns K, Sivakumaran T, van den Ouweland JMW, Pennings RJE, Cremers CWRJ, Flothmann K, Young T-L, Smith RJH, Lesperance MM, Van Camp G. Mutational spectrum of the WFS1 gene in Wolfram syndrome, nonsyndromic hearing impairment, diabetes mellitus and psychiatric genetics *Hum Mut* 2003;22 275-287
- 57 Kadayıfci A, Kepekci Y, Coskun Y, Huang Y Wolfram syndrome in a family with variable expression. *Acta Medica (Hradec Kralove)* 2001;44 115-118.
- 58 El-Shanti H, Lidral AC, Jarrah N, Druhan L, Ajlouni K Homozygosity mapping identifies an additional locus for Wolfram syndrome on chromosome 4q *Am J Hum Genet* 2000;66:1229-1236
- 59 Al-Shayyab M, Jarrah N, Younis E, Shennak MM, Hadidi A, Awidi A, El-Shanti H, Ajlouni K Bleeding tendency in Wolfram syndrome. a newly identified feature with phenotype genotype correlation. *Eur J Pediatr* 2001;160:243-246
- 60 Minton JAL, Hattersley AT, Owen K, McCarthy MI, Walker M, Latif F, Barrett T, Frayling TM. Association studies of genetic variation in the WFS1 gene and type 2 diabetes in U.K. populations *Diabetes* 2002;51 1287-1290

- 
- 61 Domènech E, Gómez-Zaera M, Nunes V. *WFS1* mutations in Spanish patients with diabetes mellitus and deafness. *Eur J Hum Genet* 2002;10 421-426
- 62 Awata T, Inoue K, Kurihara S, Ohkubo T, Inoue I, Abe T, Takino H, Kanazawa Y, Katayama S. Missense variations of the gene responsible for Wolfram syndrome (*WFS1/wolframin*) in Japanese possible contribution of the Arg456His mutation to type 1 diabetes as a nonautoimmune genetic basis. *Biochem Biophys Res Comm* 2000;268 612-616.
- 63 Swift RG, Polymeropoulos MH, Torres R, Swift M. Predisposition of Wolfram syndrome heterozygotes to psychiatric illness. *Mol Psychiatry* 1998;3 86-91.
- 64 Furlong RA, Ho LW, Rubinsztein JS, Michael A, Walsh C, Paykel ES, Rubinsztein DC. A rare coding variant within the *wolframin* gene in bipolar and unipolar affective disorder cases. *Neurosci Lett* 1999;277:123-126.
- 65 Crawford J, Zielinski MA, Fisher LJ, Sutherland GR, Goldney RD. Is there a relationship between Wolfram syndrome carrier status and suicide? *Am J Med genet* 2002;114:343-346
- 66 Sivakumaran TA, Lesperance MM. *WFS1* Gene Mutation and Polymorphism Database. World Wide Web URL: [http://www.khri.med.umich.edu/research/lesperance\\_lab/lfsnhl.shtml](http://www.khri.med.umich.edu/research/lesperance_lab/lfsnhl.shtml) accessed September 2003
- 67 Torres R, Leroy E, Hu X, Kativanou A, Gourzis P, Papachatzopoulou A, Athanassiadou A, Beratis S, Collier D, Polymeropoulos MH. Mutation screening of the Wolfram syndrome gene in psychiatric patients. *Mol Psychiatry* 2001;6 39-43
- 68 Cryns K, Pfister M, Pennings RJE, Bom SJH, Flothmann K, Caethoven G, Kremer H, Schatteman I, Köln KA, Tóth T, Kupka S, Blin N, Nurnberg P, Thiele H, van de Heyning PH, Reardon W, Stephens D, Cremers CWRJ, Smith RJH, Van Camp G. Mutations in the *WFS1* gene that cause low-frequency sensorineural hearing loss are small non-inactivating mutations. *Hum Genet* 2002;110 389-394
- 69 Takeda K, Inoue H, Tanazawa Y, Matsuzaki Y, Oba J, Watanabe Y, Shinoda K, Oka Y. *WFS1* (Wolfram syndrome 1) gene product: predominant subcellular localization to endoplasmic reticulum in cultured cells and neuronal expression in rat brain. *Hum Mol Genet* 2001;10.477-484.
- 70 Cryns K, Thys S, Van Laer L, Oka Y, Pfister M, Van Nassauw L, Smith RJH, Timmermans J-P, Van Camp G. The *WFS1* gene, responsible for low frequency sensorineural hearing loss and Wolfram syndrome, is expressed in a variety of inner ear hair cells. *Histochem Cell Biol* 2003;119 247-256.



# 1.3

---

A MOLECULAR GENETIC  
APPROACH TO SENSORINEURAL  
HEARING IMPAIRMENT





---

## HISTORICAL PERSPECTIVE AND INTRODUCTION

Adam Politzer, nowadays regarded as one of the pioneers in Otology, was born in 1835 in Albertirsa, about 35 kilometres from Budapest. He studied medicine in Vienna and received his doctorate in 1859. After this he started working at the laboratory of Carl Ludwig, where he performed research on the physical principles of the auditory system. It was at this laboratory that he developed the politzerisation technique, which made him famous.<sup>1</sup> In his second edition of the “Lehrbuch der Ohrenheilkunde”, published in 1887, he emphasised that many individuals suffer from HI that is caused by genetic factors.<sup>2</sup> Being a well-known otologist, he made heredity as one of the etiological factors of HI an accepted concept in modern western otology. Politzer realised that genetics played an important role in HI on the basis of studies published in 1880 by his colleague Arthur Hartmann, who recognised indirect (recessive) and direct (dominant) transmission of deafness.<sup>3</sup> Hartmann performed a detailed study of deafmute individuals, visited schools and centres for the deaf and presented pedigrees of families with hereditary deafness. He was also one of the first to emphasise the importance of histopathological examinations of the temporal bones of patients with HI.

Of all sensory disorders, HI is the most prevalent one. HI or deafness is seen in 1:1000 neonates. In more than 50% of the prelingual cases, the HI is caused by genetic factors.<sup>4,5,6</sup> The prevalence of postlingual deafness in western Europe, with an average hearing threshold > 25 dB, is about 1% in young adults, 10% at age < 60 years and almost 50% at 80 years.<sup>6</sup> Over the age of 65, sensorineural HI is caused by genetic as well as environmental factors. The proportion of HI due to environmental causes, such as infectious disease is decreasing with improving medical treatments. Of all hereditary cases of HI, about 30% is syndromic and 70% is nonsyndromic.<sup>7</sup> In 75% of these cases with nonsyndromic sensorineural HI there is an autosomal recessive pattern of inheritance and in about 20% the inheritance is autosomal dominant. X-linked inheritance is seen in about 5% and mitochondrial HI in less than 1%.<sup>4-8</sup> Autosomal dominantly inherited nonsyndromic sensorineural HI subtypes have the prefix DFNA followed by a number that represents the order of identification. In the majority of the DFNA patients, onset of HI is postlingual and most subtypes show progression of HI. So far, 20 genes have been identified for autosomal dominant sensorineural HI (Table 1) and 20 genes for nonsyndromic autosomal recessive sensorineural HI (Table 2),<sup>26,27</sup> which have the prefix DFNB.

Table 1. Locus, location and gene with related phenotype, in nonsyndromic types of autosomal dominant sensorineural HI (DFNA).

Locus	Location	Gene	Phenotype
DFNA1	5q31	<i>HDIA1</i>	Postlingual, low-freq., progressive all freq. <sup>9</sup>
DFNA2	1p24	<i>GJB3</i> <i>KCNQ4</i>	Postlingual, high-freq., onset 20-40yrs. <sup>10</sup> Postlingual, high-freq., progressive all freq. <sup>9</sup>
DFNA3	13q12	<i>GJB2</i> <i>GJB6</i>	Prelingual or postlingual, variable presentation and onset, downsloping audiogram. <sup>9</sup>
DFNA4	19q13	-	-
DFNA5	7p15	<i>DFNA5</i>	Postlingual, high-freq., onset 5-15 yrs. <sup>9</sup>
DFNA6/14/38 <sup>a</sup>	4p16.3	<i>WFS1</i>	Prelingual, low-freq, slow or non-progressive. <sup>9</sup>
DFNA7	1q21-q23	-	-
DFNA8/12 <sup>b</sup>	11q22-q24	<i>TECTA</i>	Prelingual, mid-frequency, stable but progressive in some cases. <sup>9</sup>
DFNA9	14q12-q13	<i>COCH</i>	Postlingual, high-freq , progressive all freq., midlife onset (40-50 yrs), vestibular dysfunction (Menière-like). <sup>9</sup>
DFNA10	6q22-q23	<i>EYA4</i>	Postlingual, all freq., progressive, onset 20-60 yrs. <sup>9</sup>
DFNA11	11q12.3-q21	<i>MYO7A</i>	Postlingual, all freq., progressive, onset 10-20 yrs. <sup>9</sup>
DFNA13	6p21	<i>COL11A2</i>	Prelingual, mid/high-freq., progressive. <sup>9</sup>
DFNA15	5q31	<i>POU4F3</i>	Postlingual, all freq., progressive, onset 20-40 yrs. <sup>9</sup>
DFNA16	2q24	-	-
DFNA17	22q	<i>MYH9</i>	Postlingual, high-freq , onset 10 yrs, moderate-severe at 30 yrs. <sup>9</sup>
DFNA18	3q22	-	-
DFNA19	10	-	-
	(pericentr)		
DFNA20/26 <sup>c</sup>	17q25	<i>ACTG1</i>	Postlingual, downsloping, progressive, onset 10-20 yrs. <sup>9</sup>
DFNA21	6p21	-	-
DFNA22	6q13	<i>MYO6</i>	Postlingual, all freq., progressive, onset 8-10 yrs. <sup>11</sup>
DFNA23	14q21-q22	-	-
DFNA24	4q	-	-
DFNA25	12q21-q24	-	-
DFNA27	4q12	-	-
DFNA28	8q22	<i>TFCP2L3</i>	Postlingual, all freq., progressive, onset 1 <sup>st</sup> decade. <sup>12</sup>
DFNA29		Reserved	
DFNA30	15q25-q26	-	-
DFNA31		Reserved	

---

DFNA32	11p15	-	
DFNA33		Reserved	
DFNA34	1q44	-	
DFNA35		Reserved	
DFNA36	9q13-q21	<i>TMC1</i>	Postlingual, high-freq., highly progressive all freq., onset 1 <sup>st</sup> decade. <sup>13</sup>
DFNA37	1p21	-	
DFNA39	4q21 3	<i>DSPP</i>	Not specified hearing loss, associated with dentinogenesis imperfecta. <sup>14</sup>
DFNA40	16p12	-	
DFNA41	12q24-qter	-	
DFNA42		Reserved	
DFNA43	2p12	-	
DFNA44	3q28-q29	-	
DFNA45		Reserved	
DFNA46		Reserved	
DFNA47	9p21-p22	-	
DFNA48	12q13-q14	<i>MYO1A</i>	Postlingual, slowly progressive, onset 1 <sup>st</sup> -3 <sup>rd</sup> decade. <sup>15</sup>
DFNA49		Reserved	
DFNA50		Reserved	
DFNA51	9q21	-	

---

<sup>a</sup> DFNA6 and DFNA14 were originally reported as non-overlapping, however, re-evaluation of the original DFNA6 family showed a phenocopy and subsequently the locus was relocated at the DFNA14 locus. DFNA38 was reserved as a new locus, however, it would have been more appropriate to use the previous loci DFNA6/14.

<sup>b</sup> DFNA8 was first linked to chromosome 15q15-q21, however, later this linkage was withdrawn and the locus relocated to the DFNA12 locus.

<sup>c</sup> DFNA20 and DFNA26 are overlapping loci and are possibly caused by mutations in the same gene

Table 2. Locus, location and gene with related phenotype, in nonsyndromic types of autosomal recessive sensorineural HI (DFNB).

Locus	Location	Gene	Phenotype
DFNB1	13q12	<i>GJB2</i> <i>GJB6</i>	Prelingual, severe-profound, occasional mild. <sup>9</sup>
DFNB2	11q13.5	<i>MYO7A</i>	Prelingual, severe-profound, vestibular dysfunction. <sup>9</sup>
DFNB3	17p11.2	<i>MYO15</i>	Prelingual, profound. <sup>9</sup>
DFNB4	7q31	<i>SLC26A4</i>	Prelingual, downsloping, progressive, enlarged vestibular aquaduct, Allelic with Pendred syndrome. <sup>9</sup>
DFNB5 <sup>a</sup>	14q12	-	
DFNB6	3p14-p21	<i>TMIE</i>	Prelingual, severe-profound deafness. <sup>16</sup>
DFNB7/11	9q13-q21	<i>TMC1</i>	Prelingual, profound. <sup>13</sup>
DFNB8/10 <sup>e</sup>	21q22	<i>TPRSS3</i>	Prelingual, profound, or onset 10-12 yrs and profound within 4-5 yrs. <sup>17</sup>
DFNB9 <sup>b</sup>	2p22-p23	<i>OTOF</i>	Prelingual, profound, possible association with auditory neuropathy. <sup>9</sup>
DFNB12	10q21-q22	<i>CDH23</i>	Prelingual, profound, in some: atypical RP, and vestibular dysfunction. <sup>9</sup>
DFNB13	7q34-36	-	
DFNB14	7q31	-	
DFNB15 <sup>c</sup>	3q21-q25/19p13	-	
DFNB16	15q21-q22	<i>STRC</i>	Postlingual, all freq moderate-severe, non-progressive, onset 3-5 yrs. Sometimes prelingual profound. <sup>18</sup>
DFNB17	7q31	-	
DFNB18	11p14-p15.1	<i>USH1C</i>	Prelingual profound, vestibular dysfunction. <sup>19</sup>
DFNB19	18p11	-	
DFNB20	11q25-qter	-	
DFNB21	11q	<i>TECTA</i>	Prelingual, severe-profound. <sup>9</sup>
DFNB22	16p12.2	<i>OTOA</i>	Prelingual, moderate-severe. <sup>20</sup>
DFNB23	10p11.2-p21	-	
DFNB24	11q23	-	
DFNB25	4p15.3-p12	-	
DFNB26 <sup>f</sup>	4q31	-	
DFNB27	2q23-q31	-	
DFNB28 <sup>d</sup>	22q13	-	
DFNB29	21q22	<i>CLDN14</i>	Prelingual profound. <sup>9</sup>
DFNB30	10p12.1	<i>MYO3A</i>	Postlingual, downsloping, progressive. <sup>21</sup>
DFNB31	9q32-34	<i>WHRN</i>	Prelingual, profound. <sup>22,23</sup>
DFNB32	1p13.3-p22 1	-	
DFNB33	9q34.3	-	

DFNB34		Reserved	
DFNB35	14q24.1-q24.3	-	
DFNB36		Reserved	
DFNB37	6q13	<i>MYO6</i>	Prelingual, profound. <sup>24</sup>
DFNB38		Reserved	
DFNB39		Reserved	
DFNB40	22q11.21-12.1	-	
n.s.	7q22.1	<i>SLC26A5</i>	Prelingual, severe-profound, non-progressive. <sup>25</sup>

<sup>a</sup> DFNB5 was reported originally as DFNB4.

<sup>b</sup> DFNB9 was reported originally as DFNB6.

<sup>c</sup> DFNB15 has identical LOD scores at both chromosomal locations.

<sup>d</sup> DFNB28 is located distally to *MYH9*.

<sup>e</sup> DFNB8 and DFNB10 first were thought not to overlap, however, both conditions are caused by mutations in the same gene (*TMPRSS3*)

<sup>f</sup> DFNB26 is suppressed by the dominant modifier DFNM1. n.s.: non-specified locus.

All identified DFNA and DFNB subtypes are shown in Table 1 and Table 2, respectively. Not only the loci and genes are shown in these tables, but a short description of the phenotype is also given when the gene involved has been identified and the phenotype was specified. Nonsyndromic autosomal recessive HI is often characterised by severe to profound congenital HI with prelingual or congenital onset.<sup>28</sup>

At this moment, over 400 syndromes with HI are listed in the OMIM (Online Mendelian Inheritance in Man) database.<sup>29,30</sup> For some of these syndromes the gene or genes involved have been cloned. With the identification of genes involved in syndromic and nonsyndromic HI and the unravelling of their function in the inner ear, the understanding of the molecular basis of auditory function has improved. In the next paragraphs, a selection of the currently identified syndromic and nonsyndromic sensorineural HI genes, their function and the associated phenotype are presented. These genes are categorised according to the known or presumed function and/or sites of expression in the inner ear. Mutations in different genes that encode proteins with a related function in the inner ear may lead to a similar type of HI. An example of this is the similarity in HI seen in DFNA8/12, caused by mutations in the *TECTA* gene and that of DFNA13, caused by mutations in the *COL11A2* gene.<sup>31,32</sup> In both conditions, a relatively stable mid-frequency hearing loss, sometimes combined with progressive high-frequency HI, is found. Both genes encode extracellular matrix proteins that are part of the tectorial membrane. Thus, phenotypic characterisation may be of assistance in the identification of the mutated gene in a new hereditary HI family trait. The HI in such a family can be analysed and compared to the known types of HI and an impression of the function of the gene involved can thus be made on the basis of similarities in phenotype.

## HAIR CELL STRUCTURE AND FUNCTION

The highly organised epithelium in the organ of Corti consists of supporting cells and rows of sensory hair cells that are specialised in the transduction of mechanical energy into electrical energy, i.e. the mechano-electrical transduction process. The apex of the hair cells carries the stereocilia. These are covered by an acellular gelatinous membrane, the tectorial membrane. Sound waves elicit motion of the basilar membrane that is located at the base of the organ of Corti. This

motion leads to deflection of the stereocilia of the outer hair cells against the tectorial membrane. This deflection opens the transduction channels in the stereocilia and thus the hair cells are depolarised. This way, mechanical energy is transduced into electrical energy. The hair cells are positioned in a single row of inner hair cells (IHC) and three rows of outer hair cells (OHC). The IHC have strong afferent connections but few efferents and the OHC have little afferent innervation and receive significant efferent feedback. The IHC transduce and transmit auditory information via their afferent synapses, whereas the OHC also transduce auditory signals but merely provide mechanical feedback and amplify the auditory stimuli sensed by the IHC, thus establishing the process of cochlear amplification.<sup>33,34</sup> Several genes are involved in the normal structure and function of the hair cells and their stereocilia. In Table 3, some deafness genes and encoded proteins are listed.

Table 3 Deafness genes expressed in hair cells

Gene	Localisation	OMIM <sup>30</sup>	Protein	Disease
<i>MYH9</i>	22q11.2	160775	Myosin heavy chain IIa	MYH9-related disease <sup>a</sup> DFNA17
<i>MYO1A</i>	12q13-q15	601478	Myosin Ia	DFNA48
<i>MYO3A</i>	10p11.1	606808	Myosin IIIa	DFNB30
<i>MYO6</i>	6q13	600970	Myosin VI	DFNA22 DFNB37
<i>MYO15</i>	17p11.2	602666	Myosin XV	DFNB3
<i>HDIA</i>	5q31	602121	Diaphanous	DFNA1
<i>ACTG1</i>	17q25	102560	Gamma actin 1	DFNA20/26
<i>STRC</i>	15q15	606440	Stereocilin	DFNB16
<i>OTOF</i>	2p23-p22	603681	Otoferlin	DFNB9 NSRAN
<i>SLC26A5</i>	7q22.1	604943	Prestin	DFNB (n.a.)
<i>WHRN</i>	9q32-q34	607928	Whirlin	DFNB31
<i>MYO7A</i>	11q13.5	276903	Myosin VIIa	DFNA11 DFNB2 USH1b
<i>USH1C</i>	11p15.1	605242	Harmonin	DFNB18 USH1c
<i>CDH23</i>	10q21-q22	605516	Otocadherin	DFNB12 USH1d
<i>SANS</i>	17q24-q25	607696	SANS	USH1g
<i>PCDH15</i>	10q21-q22	605514	Protocadherin 15	USH1f

<sup>a</sup>, MYH9-related disease: May-Hegglin anomaly, Sebastian syndrome, Fechtner syndrome, Epstein syndrome and Alport-like syndromes, NSRAN: nonsyndromic recessive auditory neuropathy  
n.a.: not assigned, OMIM: Online Mendelian Inheritance in Man<sup>30</sup>

Several myosins play an essential role in hearing. These motor molecules bind to actin and hydrolyse ATP. They contain a motor domain, which is attached to a tail



through a flexible neck region. To date, six different myosin-encoding genes are known to be involved in nonsyndromic HI, *MYO1A*, *MYO3A*, *MYO6*, *MYO7A*, *MYO15* and *MYH9*. *MYH9* encodes the myosin IIa heavy chain protein, a conventional nonmuscle myosin, whereas the remaining genes encode unconventional myosins. Mutations in *MYH9* result in a spectrum of autosomal dominant platelet disorders (Fechtner syndrome, May-Hegglin anomaly, Sebastian syndrome, Epstein syndrome and Alport-like syndromes), which are mainly characterised by giant platelets and thrombocytopenia. Depending on the syndrome other features are characteristic leukocyte inclusions (Döhle-like bodies), nephritis, deafness and cataracts.<sup>35</sup> In addition, mutations in this gene cause DFNA17, which is characterised by severe progression of HI.<sup>36</sup>

The genes encoding the motor molecules myosin Ia, myosin IIIa, myosin VI and myosin XV are all expressed in the cochlea and the proteins are likely to have a specific function in the hair cells. Mutations in *MYO1A* cause DFNA48, which may be a frequent type of sensorineural HI.<sup>15</sup> Still little is known about the DFNA48 phenotype and the function of myosin Ia. DFNB30 is caused by mutations in the *MYO3A* gene.<sup>21</sup> The expression of myosin IIIa is highly restricted to the hair cells in the cochlea and the photoreceptors of the retina and thus may be involved in Usher syndrome as well.<sup>37</sup> HI in the DFNB30 family started to increase in the second decade of life and by age 50 it was severe in the high and mid frequencies and moderate in the low frequencies.<sup>21</sup> DFNA22 and DFNB37 are both caused by mutations in the *MYO6* gene. Myosin VI is expressed in the IHC and OHC of the cochlea as well as in the retina, which makes also this gene a candidate Usher syndrome gene.<sup>11,24</sup> DFNA22 shows progressive and postlingual HI with onset during childhood. At the age of 50, all affected individuals are profoundly hearing impaired.<sup>11</sup> Recessive mutations in *MYO6* lead to profound congenital deafness, designated DFNB37, in 3 Pakistani families.<sup>24</sup> Mutations in the *MYO15* gene cause DFNB3 and lead to congenital profound sensorineural HI in 2% of the inhabitants of an Indonesian village.<sup>38</sup> Myosin XV is presumed to play a role in the proper development of the sensory epithelium of the inner ear.<sup>39</sup>

Mutations in the *HDIA* gene were found to cause DFNA1,<sup>40</sup> the first locus that was found for autosomal dominant sensorineural HI. The patients from the DFNA1 family from Costa Rica have progressive low-frequency HI and so far no other families with this type of HI are known.<sup>41</sup> It is hypothesised that the *HDIA*

encoded protein diaphanous is involved in the regulation of actin polymerisation in hair cells.<sup>40</sup>

Recently, van Wijk et al.<sup>42</sup> identified mutations in the gamma actin 1 (*ACTG1*) gene in a Dutch DFNA20/26 family. Gamma actin 1 is present in the stereocilia, cuticular plate and zonula adherens and thus constitutes an important structural element of the inner ear hair cells. The identified mutation probably leads to impairment of actin polymerization. The severity of progression in HI in the DFNA20/26 family resembled the progression described for DFNA1 (*HDIA1*), DFNA17 (*MYH9*) and DFNA22 (*MYO6*), which also are functionally related to actin in the cochlear hair cells.<sup>42</sup>

Another gene whose product is involved in the maintenance and elongation of the stereocilia of both IHC and OHC is *WHRN*. Recessive mutations in this gene cause profound prelingual HI (DFNB31) in a Palestinian family from Jordan.<sup>22</sup> *WHRN* encodes whirlin, which is a PDZ domain-containing molecule that is suggested to act as an organiser of submembranous molecular complexes that control the coordinated actin polymerisation and membrane-growth of stereocilia.<sup>23</sup>

Another important protein for the maintenance of hair cell integrity is stereocilin, encoded by the *STRC* gene. Stereocilin is exclusively expressed in the hair cells of the inner ear and mutations in *STRC* cause DFNB16.<sup>18</sup> Stereocilin and otoancorin, encoded by *OTOA* and involved in DFNB22, share sequence similarities and are thought to be responsible for the attachment of acellular gels to both sensory and nonsensory cells of the inner ear.<sup>43</sup> Otoancorin is, however, classified as an extracellular matrix protein and is therefore shown in Table 5 listing the extracellular matrix proteins.

Otoferlin is the protein that is encoded by the *OTOF* gene. Mutations in this gene lead to DFNB9 and/or to NSRAN (nonsyndromic recessive auditory neuropathy).<sup>44</sup> Speech perception in DFNB9 patients is more disturbed than would be expected from the degree of HI. Otoferlin is expressed in the IHC. The exact role otoferlin plays in the inner ear is still unclear, although it has been suggested to be involved in membrane trafficking activated by increased local  $Ca^{2+}$  concentration.<sup>44</sup>

In contrast to otoferlin, which is expressed in the IHC of the cochlea, prestin is expressed in the OHC of the cochlea.<sup>25</sup> Prestin is a motor protein which senses the membrane potential and drives rapid length changes in OHC and is therefore part of the elusive cochlear amplifier system.<sup>25</sup> It belongs to the solute carrier 26 family (SLC26), that encodes anion transporters and related proteins. *SLC26A5* is the encoding gene and mutations have been identified to cause nonsyndromic recessive HI. So far, a DFNB-locus has not been assigned.<sup>45</sup>

### *Usher syndrome type I genes*

Several Usher syndrome type I genes have so far been identified and experimental data suggest that the proteins of *MYO7A*, *USH1C*, *CDH23* and *SANS* form a complex that is essential for normal stereocilia development and function.<sup>46,47</sup> This functional complex will be described, after the separate description of these genes.

Mutations in *MYO7A* are responsible for DFNA11, DFNB2 and Usher syndrome type Ib.<sup>48-51</sup> USH1b is the most frequent subtype of Usher syndrome type I, with an estimated prevalence of about 40-50% of all Usher syndrome type I cases. USH1b and DFNB2 show congenital profound HI,<sup>50,51</sup> whereas the HI in DFNA11 is much milder (Table 1).<sup>49</sup> The mutation in *MYO7A* that leads to DFNA11 has been suggested to have a dominant negative effect that leads to defective dimers. Thus, 25% of the dimers still have two copies of wild-type myosin VIIa.<sup>49</sup> In USH1b and DFNB2 both alleles are mutated, but there is still no explanation for the difference in retinal phenotype.<sup>50,51</sup>

Immunofluorescence studies of myosin VIIa in rat tissue have shown that it is expressed in the apical stereocilia and in the cytoplasm of the IHC and OHC of the cochlea.<sup>52</sup> In the absence of myosin VIIA, the stereocilia are disorganised, whereas the lateral links and tip links between the stereocilia and the shape of the kinocilium in the vestibular hair cells appear to be normal.<sup>53,54</sup> The hair cell bundles need to be displaced beyond their physiological operating range to open the mechanotransducer channels. Therefore, it has been suggested that myosin VIIa plays a key role in adjusting the tension of the tip-link/transduction channel complex.<sup>29,54</sup> In conclusion, myosin VIIa probably participates in anchoring and holding membrane-bound elements to the rigid actin core of the stereocilium and is therefore required for the normal gating of transducer channels.

In the eye, myosin VIIa is expressed in the apical actin-rich domain of the retinal pigment epithelium and in the connecting cilia of the rod and cone photoreceptor cells.<sup>55-57</sup> In the retinal pigment epithelium (RPE), myosin VIIa is involved in the transport of melanosomes in an apical direction and in normal phagocytosis of ingested photoreceptor outer segment disks, because the ingested phagosomes are not cleared normally from the RPE apical processes into the cell body.<sup>58-60</sup>

The gene involved in Usher syndrome 1c, *USH1C*, was identified by two different research groups.<sup>61,62</sup> *USH1C* consists of 28 exons, of which 20 are constitutive and 8 are alternatively spliced. It encodes a PDZ-domain containing protein named harmonin.<sup>61</sup> Recent studies have shown that mutations in *USH1C* cause USH1c in populations of different ethnic backgrounds.<sup>19,61-64</sup> Mutations in the *USH1C* gene not only cause USH1c, but also DFNB18.<sup>19</sup> In the inner ear, harmonin is present in the organ of Corti, mainly in the cuticular plate and stereocilia, and in the vestibular hair cells.<sup>46,61</sup> So far, only little is known about the expression and function of harmonin in the eye. However, as cadherin 23 and harmonin are shown to interact,<sup>65</sup> it may well be possible that harmonin, like cadherin 23, is expressed in the photoreceptor layer of the eye.<sup>65</sup>

*CDH23* encodes cadherin 23 and is the gene involved in USH1d and DFNB12.<sup>66,67</sup> Mutation analysis of *CDH23* in a large number of families with USH1d or DFNB12 has revealed that in USH1d most mutations lead to truncation of the protein, whereas only missense mutations that alter the protein are detected in DFNB12 families.<sup>66,68-72</sup> In addition, it was shown that some DFNB12 patients have asymptomatic RP-like abnormalities in the retina.<sup>68,69,71</sup> The clinical features of 3 USH1d families and 1 DFNB12 family are described in Chapter 3.1 of this thesis.<sup>71</sup> Studies in the *waltzer* mouse have shown that *Cdh23* is expressed in the neurosensory epithelia containing cochlear and vestibular hair cells and that stereocilia organisation is disrupted during hair cell differentiation.<sup>73</sup> Cadherin 23 is a member of the cadherin superfamily of cell-cell adhesion molecules.<sup>73</sup> Based on experimental data it has been hypothesised that cadherin 23 is present at the surface of the growing stereocilia and through homophilic interaction it forms transient lateral links that interconnect the stereocillia from their emergence to their final maturation.<sup>46</sup> Modelling of DFNB12 mutations in *CDH23* showed that these missense mutations directly impair the calcium binding of the extracellular cadherin domains.<sup>69</sup> Calcium provides rigidity to the elongated structure of cadherin molecules and enables homophilic lateral interactions. It is therefore

hypothesised that mutations at these sites are likely to impair the interactions of cadherin 23 either with cadherin 23 or with other proteins.<sup>69</sup> *CDH23* is expressed in the photoreceptor layer of the retina, however, its exact retinal function still remains to be elucidated.<sup>65,72</sup>

Usher syndrome type Ig (USH1g) is caused by mutations in the *SANS* gene, the most recently identified Usher syndrome type I gene.<sup>47</sup> The *SANS* protein contains three ankyrin domains and a sterile alpha motif. Its C-terminal tripeptide presents a class I PDZ-binding motif. *SANS* and harmonin interact and therefore *SANS* is suggested to be part of the complex that shapes the hair cell bundle. So far, nothing is known about the function of *SANS* in the retina.<sup>47</sup>

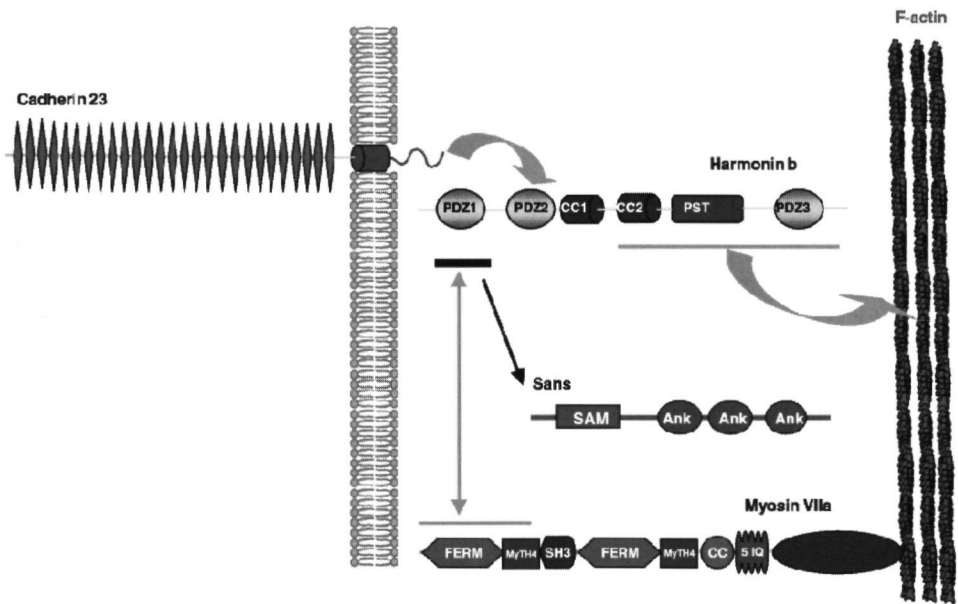

Figure 1. Schematic presentation of the interactions between myosin VIIa (USH1b), harmonin (USH1c), cadherin 23 (USH1d) and *SANS* (USH1g) in the stereocilia of the hair cells (*adapted with permission from Weil et al.*<sup>47</sup>)

The proteins of the four previously described genes (*MYO7A*, *USH1C*, *CDH23* and *SANS*) are involved in a functional network that is responsible for the correct cohesion of the hair bundles, as is shown in Figure 1.<sup>46,47</sup> Boëda et al. proposed the following molecular scenario.<sup>46</sup> Myosin VIIa first transports harmonin isoform b to its stereociliar localisation. Then, harmonin b binds the cadherin 23-containing

interstereociliar links to the actin filament cores of the developing stereocilia. These early connections between growing stereocilia seem to be critical for the correct and coherent shaping of the hair cell bundle. A failure in this process therefore leads to the observed disorganisation of the hair bundles.<sup>46</sup> In addition, it also seems likely that in this functional network other USH1 genes will play important roles. *SANS* was the first gene for which this was suggested to be the case as it directly interacts with harmonin.<sup>47</sup> Hypothetically, these proteins may also interact in the retina and form a similar functional complex in the photoreceptor cell layer. Dysfunction of this complex may thus cause RP.

Usher syndrome type If (USH1f) is caused by mutations in *PCDH15*, which encodes protocadherin 15.<sup>74,75</sup> Together with USH1d, USH1f is believed to be the second most frequent cause of Usher syndrome type I. The USH1F locus shows overlap with the DFNB23 locus, however, so far no disease-causing mutations in *PCDH15* have been reported in DFNB23 families.<sup>26</sup> Protocadherin 15 has 11 cadherin repeats, which probably are involved in Ca<sup>2+</sup> dependent cell adhesion, at least one transmembrane domain and a cytoplasmic domain. Expression studies have shown that it is not only expressed in the retina and in the hair cells of the cochlea, but also in many other tissues.<sup>74-77</sup> Because there are no additional symptoms found in patients with USH1f, it is suggested that there may be a level of redundancy in some tissues that is provided by other types of protocadherins.<sup>75</sup> Protocadherin 15 may also be part of the myosin VIIa-cadherin 23-SANS-harmonin complex since the *ames waltzer* mice with a mutation in *Pcdh15* present with disorganised stereocilia as well. So far, the function of protocadherin 15 in the retina is relatively unknown.

## ION HOMEOSTASIS AND K<sup>+</sup> RECYCLING

The inner ear consists of a bony labyrinth and a membranous labyrinth. The cochlea comprises three parallel ducts: the scala tympani, the scala media and the scala vestibuli. The scala tympani and scala vestibuli are filled with perilymph, a fluid that is rich in Na<sup>+</sup> and low in K<sup>+</sup>. The scala media is filled with endolymph, rich in K<sup>+</sup> and low in Na<sup>+</sup> ions. The scala media is separated from the scala tympani by the basilar membrane and from the scala vestibuli by Reissner's membrane. Deflection of the hair cell stereocilia in the direction of the largest stereocilium results in the mechanical opening of apical cation-selective channels.

$K^+$  ions flow from the endolymph into the hair cell and cause depolarisation. The depolarisation of the hair cell opens voltage-gated  $Ca^{2+}$  channels and the  $Ca^{2+}$  influx triggers a neurotransmitter release that stimulates the auditory nerve endings, which then transfers the signal to the brain. The apical influx of  $K^+$  ions is coupled to a  $K^+$  efflux in the basolateral membrane of the hair cells. The  $K^+$  ions are transported back to the endolymph through a mechanism of gap junctions and pumps that is called the fibrocyte gap junction system. Within the cochlea this system consists of supporting cells, fibrocytes, basal and intermediate cells of the stria vascularis. Finally, the  $K^+$  ions are released into the endolymph through the marginal cells of the stria vascularis (Figure 2). This recycling process of  $K^+$  is essential to repolarise the hair cells and to prevent cytotoxic effects on the hair cells due to a high  $K^+$  concentration. Ion homeostasis of the endolymph is crucial for optimal function of the hair cells and several gene products have been found to be involved in this process. This paragraph describes some of the genes involved in ion homeostasis in the inner ear (Table 4).<sup>27,33,34</sup>

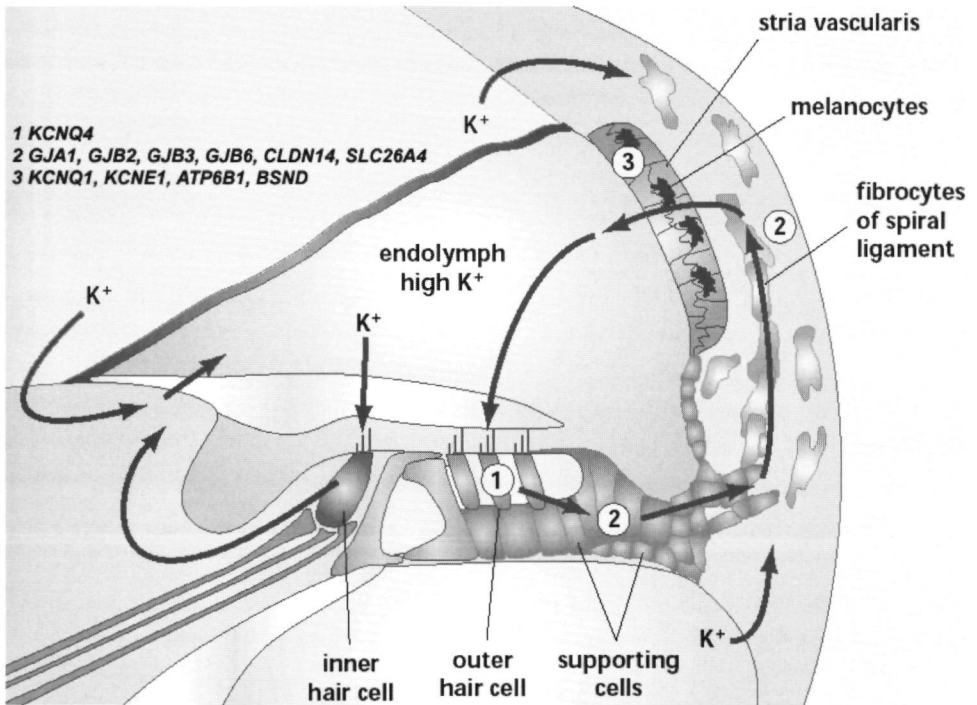

Figure 2. Presentation of the cochlear duct and the proposed  $K^+$  recycling pathways from the cochlear hair cells to the endolymph. (adapted and modified with permission from Steel and Kros<sup>29</sup>)

Four genes encoding gap junction proteins involved in endolymph homeostasis, have been identified: *GJA1*, *GJB2*, *GJB3* and *GJB6*. Gap junction proteins are intercellular channels that enable the passage of small ions and metabolites.<sup>78</sup> A complete intercellular channel consists of two connexons and each connexon consists of six connexins (hexamer). Mutations in these gap junction genes cause dominant and recessive nonsyndromic HI but may also cause syndromic HI (Table 4). Mutations in the *GJB2* gene encoding CX26, seem to account for recessive nonsyndromic HI in almost 50% of all patients in Southern Europe.<sup>27,79</sup> A lower percentage, about 10-20%, is found in Northern Europe.<sup>80</sup> The by far most prevalent mutation in CX26 is the 35delG mutation, which leads to a severely shortened, non-functional protein.<sup>80</sup>

Table 4 Deafness genes involved in ion homeostasis/K<sup>+</sup> cycling

Gene	Localisation	OMIM <sup>30</sup>	Protein	Disease
<i>GJA1</i>	6q21-q23 2	121014	CX 43	Recessive HI
<i>GJB2</i>	13q11-q12	121011	CX 26	DFNA3 DFNB1 Keratitis-Ichtyosis-deafness syndrome Palmoplantar hyperkeratosis and deafness Palmoplantar keratoderma and deafness Vohwinkel's syndrome
<i>GJB3</i>	1p35 1	603324	CX 31	DFNA2 Neuropathy and HI
<i>GJB6</i>	13q12	604418	CX 30	Recessive HI DFNA3 DFNB1
<i>KCNQ1</i>	11p15 5	607542	KvLQT1	Jervell and Lange-Nielsen syndrome 1
<i>KCNQ4</i>	1p34	603537	KCNQ4	DFNA2
<i>KCNE1</i>	21q22 1-q22.2	176261	IsK	Jervell and Lange-Nielsen syndrome 2
<i>SLC19A2</i>	1q23 3	603941	THTR-1	Thiamine-responsive megaloblastic anemia with diabetes mellitus and deafness
<i>SLC26A4</i>	7q31	605646	Pendrin	DFNB4 Pendred syndrome
<i>CLDN14</i>	21q22 3	605608	Claudin 14	DFNB29
<i>ATP6B1</i>	2cen-q13	192132	ATP6B1	Renal tubular acidosis and HI
<i>BSND</i>	1p31	602522	Barttin	Bartter syndrome and HI

OMIM Online Mendelian Inheritance in Man <sup>30</sup>

Also potassium channels are involved in ion homeostasis of the inner ear. Currently, three genes encoding potassium channel proteins are involved in HI: *KCNQ1*, *KCNQ4* and *KCNE1*. *KCNQ4* mutations are causative for a progressive type of high-frequency HI entitled DFNA2, whose phenotype is described in the last section of this introduction.<sup>81</sup> *KCNQ1* and *KCNE1* both are involved in the



Jervell and Lange-Nielsen syndrome, a rare autosomal recessive disorder characterised by congenital deafness and long QT interval.<sup>82</sup> Dominant mutations lead to the Romano-Ward syndrome, which is characterised by syncope and a prolonged QT interval without associated HI.<sup>27</sup>

Recessive mutations in the *SLC26A4* gene cause DFNB4 and Pendred syndrome.<sup>83</sup> Pendred syndrome is characterised by HI and goiter. These patients have an enlarged vestibular aqueduct, as well as an enlarged endolymphatic sac and duct on CT and MRI scans. Progression and fluctuation of hearing is reported in childhood or adolescence and seem to relate to head injury, infection or delayed secondary hydrops.<sup>84,85</sup> Pendrin is a transmembrane protein that functions as a sodium-independent cotransporter of chloride and anions.<sup>86</sup> Another member of the solute carrier families is also known to be involved in inner ear ion homeostasis: *SLC19A2*.<sup>87</sup> This gene has an entirely different function because it is a thiamine transporter gene. Mutations in this gene cause the autosomal recessive Rogers syndrome more commonly referred to as Thiamin-Responsive Megaloblastic Anaemia syndrome (TRMA) characterised by megaloblastic anaemia, diabetes mellitus and sensorineural HI. This disease responds in varying degrees to thiamine administration.<sup>87</sup>

Recessive mutations in the *CLDN14* gene cause DFNB29. This gene encodes claudin 14, which is a tight-junction protein.<sup>88</sup> The main function of tight junctions is to maintain epithelial cell polarity and to selectively modulate paracellular permeability between extracellular compartments. Tight junctions in the cochlear duct are necessary to compartmentalise the endolymph and to provide structural support to the auditory neuroepithelium.<sup>88</sup>

Two genes are not only involved in inner ear ion homeostasis but also in renal disorders. The first gene, *ATP6B1*, encodes the B1-subunit of H<sup>+</sup>-ATPase and mutations in this gene cause autosomal recessive distal renal tubular acidosis combined with progressive HI.<sup>89</sup> The protein probably plays a role in maintaining the correct pH of the endolymph and mutations in this gene lead to an increase in pH and subsequently to hearing loss due to impaired hair cell function. The protein is expressed in the cochlea as well as the endolymphatic sac.<sup>89</sup> Bartter syndrome is a heterogeneous, autosomal recessive salt-losing nephropathy. The fourth, antenatal type of Bartter syndrome presents with sensorineural HI and renal failure and is caused by mutations in the *BSND* gene, which encodes

barttin.<sup>90</sup> Barttin is an essential  $\beta$ -subunit of the ClC-Ka and ClC-Kb chloride channels. It is expressed in the basolateral membranes of renal tubules and in the potassium-secreting epithelia of the inner ear and is crucial for renal salt absorption and potassium recycling in the inner ear.<sup>91</sup>

## TRANSCRIPTION FACTORS

Transcription factors are gene regulatory proteins. These proteins have DNA binding capacity to short recognisable nucleotide sequences. Transcription factors control RNA transcription and genes can be switched on or off by activation or repression. Important transcription factors control many other genes in a coordinated sequential cascade thereby regulating fundamental developmental processes such as segmentation, induction, differentiation, migration and apoptosis. Mutations in transcription factor genes may result in isolated malformations or in multiple congenital syndromes.<sup>92</sup> In the present section, some of the transcription factors with a function in the inner ear are described (Table 5).

Table 5. Deafness genes that encode transcription factors involved in the cochlea

Gene	Localisation	OMIM <sup>30</sup>	Protein	Disease
<i>POU3F4</i>	Xq21.1	300039	POU3F4	DFN3 (Stapes Gusher syndrome)
<i>POU4F3</i>	5q31	602460	POU4F3	DFNA15
<i>EYA1</i>	8q13.3	601653	EYA1	Branchio-oto-renal syndrome (BOR)
				Branchio-oto syndrome
<i>EYA4</i>	6q23	603550	EYA4	DFNA10
<i>PAX3</i>	2q35	606597	PAX3	Waardenburg syndrome 1
				Waardenburg syndrome 3
				Craniofacial-deafness-hand syndrome
<i>MITF</i>	3p14.1- p12.3	156845	MITF	Waardenburg syndrome 2
				Tietz syndrome
<i>SOX10</i>	22q13	602229	SOX10	Waardenburg syndrome 4
				Peripheral neuropathy with hypomyelination and deafness
				Yemenite deaf-blind hypopigmentation
<i>TFCP2L3</i>	8q22	-	TFCP2L3	DFNA28
<i>GATA3</i>	10p15	131320	GATA3	Hypoparathyroidism, deafness and renal dysplasia
<i>SALL1</i>	16q12.1	602218	SALL1	Townes-Brocks syndrome

OMIM: Online Mendelian Inheritance in Man.<sup>30</sup>

Two genes encode POU domain transcription factors and the POU domains are involved in high-affinity binding to DNA target sites. *POU3F4* plays a crucial role in the patterning of the mesenchymal compartment of the inner ear. Mutations in

*POU3F4* are responsible for DFN3, an X-linked type of HI that shows mixed conductive and perceptive HI.<sup>93</sup> The conductive part of the HI is caused by congenital fixation of the stapedial footplate. Perilymphatic gusher appears when the stapedial footplate is opened in order to replace the fixed stapes, therefore DFN3 is also referred to as the stapes gusher syndrome.<sup>94</sup> The widened vestibule associated with DFN3 can contribute to an air-bone gap in the pure tone audiogram as the result of leakage of sound energy on its way from the stapedial footplate to the inner ear hair cells. Another POU domain containing protein is encoded by *POU4F3*. Mutations within this gene cause DFNA15.<sup>95</sup> The phenotype of DFNA15 is more extensively described in the last section of this introduction.<sup>81</sup>

Waardenburg syndrome is an autosomal dominantly inherited syndrome that is known for its clinical and genetic heterogeneity. Four clinically different types are distinguished (WS1-WS4). In general, the major symptoms of Waardenburg syndrome are congenital sensorineural HI, pigmentation abnormalities of the iris (heterochromia iridis), white forelock and hypopigmentation of the skin.<sup>96</sup> So far, mutations in 6 different genes have been identified. Four genes encode transcription factors (*PAX3*, *MITF*, *SLUG* and *SOX10*)<sup>97-100</sup> and two genes (*EDN3* and *EDNRB*) encode a ligand (endothelin 3)<sup>101</sup> and its receptor (endothelin receptor B)<sup>102</sup>. Mutations in the latter two genes cause WS4 and are described in the paragraph on receptors and ligands. WS1 and WS2 are by far the most common types of the syndrome. WS1 is caused by mutations in *PAX3*, and WS2 is caused by mutations in the *MITF* and *SLUG* gene.<sup>97-99</sup> WS3 is also caused by mutations in the *PAX3* gene and mutations in *SOX10* are responsible for WS4.<sup>100,103</sup> WS1 and WS3, also known as the Klein-Waardenburg syndrome, can be distinguished from WS2 and WS4 on the basis of lateral displacement of the medial canthi combined with dystopia of the lacrimal punctae and blepharophimosis. Also, WS3 shows upper limb defects.<sup>96</sup> *MITF* and *PAX3* are both involved in the migration and differentiation of neural crest cells. During embryogenesis, part of these cells develop into melanocytes and migrate to their final position in various organs. It has been suggested that absence of melanocytes causes a white forelock, iris pigmentation abnormalities and in the stria vascularis it may lead to sensorineural HI.<sup>104</sup>

Another family of transcription factors involved in syndromic and nonsyndromic HI is the family of *EYA* genes. These genes are named after the eyes absent (*Eya*) gene of *Drosophila*. Mutations in *EYA1* are responsible for Branchio-Oto-Renal

syndrome (BOR) and Branchio-Oto syndrome (BO).<sup>105,106</sup> BOR is an autosomal dominant syndrome that is characterised by 1 hearing loss (of conductive, perceptive or mixed origin) 2 second branchial arch fistula or cyst/preauricular sinus including ear pits 3 malformed auricles, ear canal, middle and/or inner ear and 4 renal anomalies ranging from mild hypoplasia to complete agenesis. Stenosis of the nasolacrimal duct is also common in these patients.<sup>107,108</sup> Recently, a long-term follow-up study of BOR syndrome patients reported that HI has a progressive and fluctuating character.<sup>109</sup> This study demonstrated that these patients also may have an enlarged vestibular aqueduct and cochlear hypoplasia, which can be seen on CT scans.<sup>109</sup> The BO syndrome shows similar features as seen in BOR syndrome, however, without renal anomalies.

The Townes-Brocks or REAR (Renal-Ear-Anal-Radial) syndrome is another syndrome that resembles BOR syndrome. REAR shows autosomal dominant inheritance with variable expression. Major symptoms are renal malformations, external ear anomalies (lop ear, microtia, preauricular pits or tags), sensorineural HI, imperforate anus and preaxial polydactyly or triphalangeal thumbs. The syndrome is caused by mutations in *SALL1*. This gene encodes a zinc finger transcription factor.<sup>110</sup> Mutations in the *GATA3* gene, another zinc finger transcription factor, are responsible for the syndromic association of Hypoparathyroidism, Deafness and Renal dysplasia, also referred to as HDR syndrome.<sup>111</sup> The last transcription factor gene shown in Table 5 is *TFCP2L3*. Mutations in this gene are responsible for a progressive, late onset type of nonsyndromic sensorineural HI, DFNA28.<sup>12</sup> The function of this transcription factor in the cochlea is still poorly understood.

## EXTRACELLULAR MATRIX PROTEINS

Several extracellular matrix proteins are essential for normal inner ear function. A number of these will be described in this paragraph. The tectorial membrane is an acellular gelatinous mass overlying the hair cells. When the basilar membrane is moved due to a sound wave, the stereocilia of the OHC bend against the tectorial membrane. The tectorial membrane is made of noncollagenous glycoproteins and collagens. One of the important glycoproteins is encoded by the  $\alpha$ -tectorin gene *TECTA*, which is mutated in DFNA8/12 and DFNB21.<sup>112,113</sup> The HI known for DFNB21 is characterised by severe to profound prelingual hearing loss at all

frequencies.<sup>113</sup> A genotype-phenotype correlation study of HI in DFNA8/12 families has shown that mutations in the zona pellucida domain of  $\alpha$ -tectorin are associated with stable mid-frequency HI, whereas mutations in the zonadhesin domain seem to relate to progressive high-frequency HI.<sup>114</sup> Otoanchorin is the protein encoded by the *OTOA* gene. Recessive mutations in this gene cause DFNB22, which is characterised by prelingual moderate to severe sensorineural HI.<sup>20</sup> Otoanchorin is suggested to ensure the attachment of the inner ear acellular gels to the apical surface of the underlying nonsensory cells.<sup>20</sup>

Table 6 Deafness genes encoding extracellular matrix components of the cochlea (tectorial membrane/basement membrane)

Gene	Localisation	OMIM <sup>30</sup>	Protein	Disease
<i>TECTA</i>	11q22-q24	602574	$\alpha$ -tectorin	DFNA8/12 DFNB21
<i>OTOA</i>	16p12.2	607038	Otoanchorin	DFNB22
<i>COL11A1</i>	1p21	120280	Collagen 11 $\alpha$ 1	Stickler syndrome 2 Marshall syndrome
<i>COL11A2</i>	6p21.3	120290	Collagen 11 $\alpha$ 2	DFNA13 Stickler syndrome 3 Oto-spondylo-mega-epiphyseal dysplasia (OSMED) Weissenbacher-Zweymuller syndrome
<i>COL2A1</i>	12q13.11-q13.2	120140	Collagen 2 $\alpha$ 1	Stickler syndrome 1
<i>COL4A3</i>	2q36-q37	120070	Collagen 4 $\alpha$ 3	Alport syndrome, recessive
<i>COL4A4</i>	2q36-q37	120131	Collagen 4 $\alpha$ 4	Alport syndrome, dominant
<i>COL4A5</i>	Xq22.3	303630	Collagen 4 $\alpha$ 5	Alport syndrome, recessive
<i>COCH</i>	14q12-q13	603196	Cochlin	Alport syndrome, X-linked dominant
<i>USH2A</i>	1q41	276901	Usherin	DFNA9 USH2a
<i>NDP</i>	Xp11.4	310600	Norrin	Norrie disease Coats' disease

OMIM: Online Mendelian Inheritance in Man.<sup>30</sup>

Collagens are important components of the tectorial membrane and the basement membranes in the inner ear. Six different collagen genes are currently known to be involved in syndromic and nonsyndromic sensorineural HI *COL2A1*, *COL4A3*, *COL4A4*, *COL4A5*, *COL11A1* and *COL11A2* (Table 6). Stickler syndrome is caused by mutations in collagen genes. The original description by Stickler et al. concerned a family with progressive myopia, retinal detachment and blindness, as well as premature degenerative changes in various joints.<sup>115</sup> Later on, mild HI, radiographic abnormalities, the Pierre-Robin sequence and typical orofacial features were added to the description of this syndrome.<sup>116,117</sup> The syndrome

shows autosomal dominant inheritance. Stickler syndrome is classified into three genetic subtypes on the basis of mutations in three different genes: *COL11A1*, *COL11A2* and *COL2A1*.<sup>118</sup> Mutations in *COL11A2* are also responsible for DFNA13, a nonsyndromic type of HI characterised by nonprogressive, presumably congenital mid-frequency sensorineural HI. In some families there is an additional high-frequency hearing loss.<sup>119</sup> The mid-frequency hearing loss in DFNA13 resembles that of DFNA8/12 and this probably relates to the fact that both proteins are components of the tectorial membrane.

Mutations in three collagen 4 genes (*COL4A3*, *COL4A4* and *COL4A5*) are responsible for Alport and related syndromes (Table 5).<sup>120</sup> The most characteristic symptom of this syndrome is nephropathy, characterised by microscopic hematuria and proteinuria, leading to end-stage renal failure in virtually all affected male patients with X-linked Alport syndrome, which is the most prevalent type. In approximately 55% of the male and 45% of the female patients, slowly progressive sensorineural HI is seen. In addition, X-linked Alport syndrome patients tend to develop ocular lesions. Anterior lenticonus, in which the central portion of the lens protrudes into the anterior chamber, is virtually pathognomonic for this condition. Corneal abnormalities have also been reported in these patients.<sup>121</sup> Alport syndrome is an inherited disorder of the basement membranes. The X-linked type of Alport syndrome is caused by mutations in *COL4A5* and the autosomal recessively inherited type of Alport syndrome is caused by mutations in *COL4A3* and *COL4A4*. In addition, heterozygous mutations in *COL4A3* and *COL4A4* were reported to cause autosomal dominant Alport syndrome, which is characterised by slow progression towards impaired renal function.<sup>120</sup>

Another type of an autosomal dominantly inherited progressive high-frequency HI (DFNA9) is caused by mutations in the *COCH* gene.<sup>122</sup> This characteristic type of HI is relatively often seen in the Netherlands and Belgium and its characteristic features, mid-life onset of progressive HI starting in the high frequencies and progressive vestibular dysfunction, are described in the review in the next section of this introduction.<sup>81</sup> *COCH* encodes cochlin, an extracellular matrix protein, and is expressed in fibrocytes of the spiral limbus and the spiral ligament in the cochlea, as well as in the fibrocytes of the connective tissue stroma underlying the sensory epithelium of the crista ampullaris.<sup>123</sup> The exact function of this protein in the inner ear is still unknown. Recent studies have shown that mutant cochlins are

not retained intracellularly and can be secreted by the cells through the Golgi/endoplasmic reticulum secretory pathway and that DFNA9 mutations probably lead to incorrect integration of cochlin into the extracellular matrix.<sup>124,125</sup>

Usherin, another extracellular matrix protein that is present in the cochlear basement membranes, is encoded by the *USH2A* gene. Mutations in this gene are responsible for USH2a.<sup>126</sup> This is the most prevalent genetic subtype of all types of Usher syndrome and is believed to account for about 80-85% of all Usher syndrome type II cases.<sup>127-129</sup> Usherin is located in the basement membranes of the cochlea and retina, as well as in those of other tissues.<sup>130,131</sup> By in situ hybridisation *USH2A* transcripts were only shown to be present in the perinuclear cytoplasm of the photoreceptor cells in the outer nuclear layer of the retina in humans, mice and rats.<sup>132</sup> However, with antibodies against usherin the protein could not be detected in this layer. In the Usher syndrome type IIa retina, the number of photoreceptors is reduced, the rods and cones are diminished in numbers with shorter outer segments, and there is virtual absence of both photoreceptors in the peripheral retina.<sup>132</sup>

Norrie disease is an X-linked syndrome, which main characteristic feature is congenital bilateral blindness due to a prominent intraocular mass (pseudoglioma). In addition, there is partial avascularity of the retina. Additional features are deafness and mental retardation. Patients with Norrie disease show progressive HI in all frequencies, but more severely in the high-frequency range, leading to profound deafness. The onset age varies widely from 4 months to 45 years. In two-thirds of the patients, mental retardation or psychotic features are seen.<sup>133</sup> Norrie disease is caused by mutations in the *NDP* gene.<sup>134</sup> Studies of a knock-out mouse model (*Ndp*) have shown that the primary lesion is located in the stria vascularis of the inner ear. Abnormal vasculature and finally a loss of two-thirds of the vessels can be seen in this region. Therefore, it was concluded that one of the main functions of norrin is to regulate the interaction of the cochlea with its vasculature.<sup>135</sup>

## RECEPTORS AND LIGANDS

Autosomal dominantly inherited Waardenburg syndrome type IV (WS4), also known as the Shah-Waardenburg syndrome, is caused by heterozygous mutations

in *SOX10*.<sup>100</sup> Homozygous or compound heterozygous mutations in the endothelin receptor B gene (*EDNRB*) and in *EDN3* encoding its ligand endothelin 3 also cause WS4, however, with autosomal recessive inheritance.<sup>101,102</sup> WS4 is characterised by the WS2 features combined with Hirschsprung disease and is part of a heterogeneous group of rare neurocristopathies in which aberrant migration of the neural crest cells results in absence or abnormal location of enteric neurons and melanocytes.<sup>101</sup> Recent studies have shown that the endothelin signalling pathway is involved in the migration of neural crest-derived melanocytes and enteric neuron precursors.<sup>136</sup>

Table 6. Other deafness genes involved in sensorineural HI.

Gene	Location	OMIM <sup>30</sup>	Protein	Disease
<b>RECEPTORS AND LIGANDS</b>				
<i>EDN3</i>	20q13.2-q13.3	131242	Endothelin 3	Waardenburg syndrome 4 Hirschprung disease
<i>EDNRB</i>	13q22	131244	Endothelin receptor B	Waardenburg syndrome 4 Hirschprung disease
<b>CELLULAR TRAFFICKING PROTEINS</b>				
<i>TIMM8A</i>	Xq22	300356	Deafness dystonia peptide	Deafness dystonia syndrome or Mohr-Tranebjærg syndrome
<b>UNKNOWN FUNCTION</b>				
<i>DFNA5</i>	7p15	600994	DFNA5	DFNA5
<i>WFS1</i>	4p16.1	606201	Wolframin	DFNA6/14/38 Wolfram syndrome
<i>TMC1</i>	9q13-q21	606706	TMC1	DFNA36 DFNB7/11
<i>TMIE</i>	3p21	607237	TMIE	DFNB6
<i>TMPRSS3</i>	21q22.3	605511	Transmembrane protease serine 3	DFNB8/10
<i>USH3</i>	3q21-q25	606397	Clarin-1	USH3
<i>DSPP</i>	4q21.3	125485	Dentin sialophosphoprotein	DFNA39

OMIM: Online Mendelian Inheritance in Man.<sup>30</sup>

## CELLULAR TRAFFICKING PROTEINS

Mutations in the *DDP1* gene (Deafness-Dystonia Peptide) cause DFN1, which was later renamed as deafness-dystonia syndrome or Mohr-Tranebjærg syndrome.<sup>137</sup> The sensorineural HI is accompanied by dystonia, fractures, mental retardation and ocular features, which gradually lead to cortical blindness.<sup>138</sup> Ocular features include myopia, decreased visual acuity, constricted visual fields and an abnormal electroretinogram. *DDP1* is located on the X chromosome and the protein is



thought to be involved in the import of carrier proteins into the mitochondria and insertion into the mitochondrial inner membrane. Therefore, the DDP1 protein is likely to affect mitochondrial oxidative phosphorylation.<sup>139,140</sup>

## GENES WHOSE FUNCTION CURRENTLY IS UNKNOWN

In the past years the number of genes known to be involved in syndromic and nonsyndromic sensorineural HI has increased considerably. For some of these genes, the function of the protein is still unknown. *DFNA5*, whose phenotype is described in the last section of this introduction,<sup>81</sup> is one of these genes.<sup>141</sup> The exact function of the *WFS1* product wolframin, which is involved in Wolfram syndrome (Chapter 4.1) and *DFNA6/14* (Chapter 5.1), is also still unknown. It has, however, been hypothesised to play an important role in endolymph homeostasis, maintained by the canalicular reticulum, a specialised type of endoplasmic reticulum in the inner ear.<sup>142</sup> The *USH3* gene is mutated in Usher syndrome type III.<sup>143</sup> This type of Usher syndrome is differentiated from other clinical types of Usher syndrome by progressive HI. The protein encoded by the *USH3* gene is named clarin-1. Although still little is known about the protein function of the gene, it may play a role in synapse function between hair cells and cochlear ganglion cells. This suggestion was made on the basis of remote similarity to stargazin.<sup>144,145</sup> Several other genes with a currently unknown function are shown in Table 6. Clinical and genetic studies will reveal the function of these proteins in the nearby future.

## REFERENCES

- 1 Who Named it?, Adam Politzer. <http://www.whonamedit.com/doctor/cfm/1756.html> , accessed September 2003
- 2 Politzer A Lehrbuch der Ohrenheilkunde fur praktische Arzte und Studierende II Band. Ferdinand Enke Stuttgart, Deutschland 1887
- 3 Hartmann A. Taubstummheit und Taubstummenbildung, nach den vorhandenen Quellen sowie nach eigenen Beobachtungen und Erfahrungen. 1880, Verlag Ferdinand Enke, Stuttgart.
- 4 Marazita ML, Ploughman LM, Rawlings B, Remington E, Arnos KS, Nance WE Genetic epidemiological studies of early-onset deafness in the U.S. school age population Am J Med Genet 1993;46:486-491
- 5 Reardon W. Genetic deafness J Med Genet 1992;29 521-526
- 6 Morton NE Genetic epidemiology of hearing impairment. Ann N Y Acad Sc 1991;630 16-31.
- 7 Gorlin RJ, Toriello HV, Cohen MM Hereditary hearing loss and its syndromes. New York Oxford University Press,1995.

- 8 Sakihira Y, Christensen B, Parving A. Prevalence of hearing impairment in adults. *Scand Audiol* 1999;28:39-40.
- 9 Cremers CWRJ, Smith RJH. Genetic Hearing impairment: Its clinical presentations. *Advances in Oto-Rhino-Laryngology* vol. 61. Basel: Karger, 2002.
- 10 Xia JH, Liu CY, Tang BS, Pan Q, Huang L, Dai HP, Zhang BR, Xie W, Hu DX, Zheng D, Shi XL, Wang DA, Xia K, Yu KP, Liao XD, Feng Y, Yang YF, Xiao JY, Xie DH, Huang JZ. Mutations in the gene encoding gap junction protein beta-3 associated with autosomal dominant hearing impairment. *Nat Genet* 1999;21:241.
- 11 Melchionda S, Ahituv N, Bisceglia L, Sobe T, Glaser F, Rabionet R, Arbones ML, Notarangelo A, Zelante L, Estivill X, Avraham KB, Gasparini P. *MYO6*, the human homologue of the gene responsible for deafness in *snell's waltzer mice*, is mutated in autosomal dominant nonsyndromic hearing loss. *Am J Hum Genet* 2001;69:635-640.
- 12 Peters LM, Anderson DW, Griffith AJ, Grundfast KM, San Augustin TB, Madeo AC, Friedman TB, Morell RJ. Mutations of a transcription factor, *TFCP2L3*, causes progressive autosomal dominant hearing loss, DFNA28. *Hum Mol Genet* 2002;11:2877-2885.
- 13 Kurima K, Peters LM, Yang Y, Riazuddin S, Ahmed ZM, Naz S, Arnaud D, Drury S, Mo J, Makishima T, Ghosh M, Menon PS, Deshmukh D, Oddoux C, Ostrer H, Khan S, Riazuddin S, Deininger PL, Hampton LL, Sullivan SL, Battey JF Jr, Keats BJ, Wilcox ER, Friedman TB, Griffith AJ. Dominant and recessive deafness caused by mutations of a novel gene, *TMCI*, required for cochlear hair-cell function. *Nat Genet* 2002;30:277-284.
- 14 Xiao S, Yu C, Chou X, Yuan W, Wang Y, Bu L, Fu G, Qian M, Yang J, Shi Y, Hu L, Han B, Wang Z, Huang W, Liu J, Chen Z, Zhao G, Kong X. *Dentinogenesis imperfecta 1* with or without progressive hearing loss is associated with distinct mutations in *DSPP*. *Nat Genet* 2001;27:201-204.
- 15 Donaudy F, Ferrara A, Esposito L, Hertzano R, Ben-David O, Bell RE, Melchionda S, Zelante L, Avraham KB, Gasparini P. Multiple mutations of *MYO1A*, a cochlear-expressed gene, in sensorineural hearing loss. *Am J Hum Genet* 2003;72:1571-1577.
- 16 Naz S, Giguere CM, Kohnman DC, Mitchem KL, Riazuddin S, Morell RJ, Ramesh A, Srisailpathy S, Deshmukh D, Riazuddin S, Griffith AJ, Friedman TB, Smith RJH, Wilcox ER. Mutations in a novel gene, *TMIE*, are associated with hearing loss linked to the *DFNB6* locus. *Am J Hum Genet* 2002;71:632-636.
- 17 Scott HS, Kudoh J, Wattenhofer M, Shibuya K, Berry A, Chrast R, Guipponi M, Wang J, Kawasaki K, Asakawa S, Minoshima S, Younus F, Mehdi SQ, Radhakrishna U, Papasavvas MP, Gehrig C, Rossier C, Korostishevsky M, Gal A, Shimizu N, Bonne-Tamir B, Antonarakis SE. Insertion of beta-satellite repeats identifies a transmembrane protease causing both congenital and childhood onset autosomal recessive deafness. *Nat Genet* 2001;27:59-63.
- 18 Verpy E, Masmoudi S, Zwaenepoel I, Leibovici M, Hutchin TP, Del Castillo I, Nouaille S, Blanchard S, Laine S, Popot JL, Moreno F, Mueller RF, Petit C. Mutations in a new gene encoding a protein of the hair bundle cause non-syndromic deafness at the *DFNB16* locus. *Nat Genet* 2001;29:345-349.
- 19 Ahmed ZM, Smith TN, Riazuddin S, Makishima T, Ghosh M, Bokhari S, Menon PSN, Deshmukh D, Griffith AJ, Riazuddin S, Friedman TB, Wilcox ER. Nonsyndromic recessive deafness in *DFNB18* and Usher syndrome type IC are allelic mutations of *USH1C*. *Hum Genet* 2002;110:527-531.
- 20 Zwaenepoel I, Mustapha M, Leibovici M, Verpy E, Goodyear R, Liu XZ, Nouaille S, Nance WE, Kanaan M, Avraham KB, Tekai F, Loiselet J, Lathrop M, Richardson G, Petit C. Otoancorin, an inner ear protein restricted to the interface between the apical surface of sensory epithelia and their overlying acellular gels, is defective in autosomal recessive deafness *DFNB22*. *Proc Natl Acad Sci* 2002;99:6240-6245.
- 21 Walsh T, Walsh V, Vreugde S, Hertzano R, Shahun H, Haika S, Lee MK, Kanaan M, King M-C, Avraham KB. From flies' eyes to our ears: mutations in a human class III myosin cause progressive nonsyndromic hearing loss *DFNB30*. *Proc Natl Acad Sci* 2002;99:7518-7523.
- 22 Mustapha M, Chouery E, Chardenoux S, Naboulsi M, Paronnaud J, Lemaire A, Mègarbané A, Loiselet J, Weil D, Lathrop M, Petit C. *DFNB31*, a recessive form of sensorineural hearing loss maps to chromosome 9q32-34. *Eur J Hum Genet* 2002;10:210-212.
- 23 Mburu P, Mustapha M, Varela A, Weil D, El-Amraoui A, Holme RH, Rump A, Hardisty RE, Blanchard S, Coimbra RS, Perfettini I, Parkinson N, Mallon A-M, Glenister P, Rogers MJ, Paige AJ, Mour L, Clay J, Rosenthal A, Liu XZ, Blanco G, Steel KP, Petit C, Borwn SDM. Defects in whirlin, a PDZ domain molecule involved in stereocilia elongation, cause deafness in the whirler mouse and families with *DFNB31*. *Nat Genet* 2003;34:421-428.
- 24 Ahmed ZM, Morell RJ, Riazuddin S, Gropman A, Shaikat S, Ahmad MM, Mohiddin SA, Fananapazir L, Caruso RC, Husnain T, Khan SN, Riazuddin S, Griffith AJ, Friedman TB, Wilcox ER. Mutations of *MYO6* are associated with recessive deafness, *DFNB37*. *Am J Hum Genet* 2003;72:1315-1322.

- 25 Liberman MC, Gao J, He DZZ, Wu X, Jia S, Zuo J. Prestin is required for electromotility of the outer hair cell and for the cochlear amplifier. *Nature* 2002;419:300-304
- 26 Van Camp G, Smith RJH. Hereditary Hearing Loss Homepage URL: <http://dnalab-www.uia.ac.be/dnalab/hhh/>, accessed September, 2003.
- 27 Bitner-Glindzic M. Hereditary deafness and phenotyping in humans. *Br Med Bull* 2002;63:73-94.
- 28 Liu X, Xu L. Nonsyndromic hearing loss: an analysis of audiograms. *Ann Otol Rhinol Laryngol* 1994;103 428-433.
- 29 Steel KP, Kros CJ. A genetic approach to understanding auditory function. *Nat Genet* 201;27:143-149
- 30 Online Mendelian Inheritance in Man, OMIM (TM) McKusick-Nathans Institute for Genetic Medicine, Johns Hopkins University (Baltimore, MD) and National Center for Biotechnology Information, National Library of Medicine (Bethesda, MD), 2000. World Wide Web URL: <http://www.ncbi.nlm.nih.gov/omim/>, accessed September 2003.
- 31 Govaerts PJ, De Ceulaer G, Daemers K, Verhoeven K, Van Camp G, Schatteman I, Verstreken M, Willems PJ, Somers T, Offeciers FE. Clinical presentation of DFNA8-DFNA12. *Adv Otorhinolaryngol* 2002;61 60-65.
- 32 De Leenheer EMR, McGuirt WT, Kunst HPM, Huygen PLM, Smith RJH, Cremers CWRJ. The phenotype of DFNA13/COL11A2. In: Cremers CWRJ, Smith RJH (eds) Genetic hearing impairment Its clinical presentations. *Advances in Oto-Rhino-Laryngology*, vol 61 Basel Karger, 2002,61:85-91
- 33 Tekin M, Arnos KS, Pandya A. Advances in hereditary deafness. *Lancet* 2001;358:1082-1090
- 34 Forge A, Wright T. The molecular architecture of the inner ear. *Br Med Bull* 2002;63 5-24
- 35 Hu A, Wang F, Sellers JR. Mutations in human nonmuscle myosin IIA found in patients with May-Hegglin anomaly and Fechtner syndrome result in impaired enzymatic function. *J Biol Chem* 2002;277:46512-46517.
- 36 Lalwani AK, Goldstein JA, Kelley MJ, Luxford W, Castelein CM, Mhatre AN. Human nonsyndromic hereditary deafness DFNA17 is due to a mutation in nonmuscle myosin MYH9. *Am J Hum Genet* 2000;67 1121-1128.
- 37 Dosé AC, Hillman DW, Wong C, Sohlberg L, Lin-Jones J, Burnside B. Myo3a, one of two class III myosin genes expressed in vertebrate retina, is localized to the calycul processes of rod and cone photoreceptors and is expressed in the sacculus. *Mol Biol Cell* 2003;14 1058-1073.
- 38 Wang A, Liang Y, Fridell RA, Probst FJ, Wilcox ER, Touchman JW, Morton CC, Morell RJ, Noben-Trauth K, Camper SA, Friedman TB. Association of unconventional myosin MYO15 mutations with human nonsyndromic deafness DFNB3. *Science* 1998;280 1447-1451
- 39 Anderson DW, Probst FJ, Belyantseva IA, Fridell RA, Beyer L, Martin DM, Wu D, Kachar B, Friedman TB, Raphael Y, Camper SA. The motor and tail regions of myosin XV are critical for normal structure and function of auditory and vestibular hair cells. *Hum Mol Genet* 2000;9:1729-1738.
- 40 Lynch ED, Lee MK, Morrow JE, Welch PL, León PE, King MC. Nonsyndromic deafness DFNA1 associated with mutation of a human homolog of the *Drosophila* gene *diaphanous*. *Science* 1997;278:1315-1318.
- 41 Lalwani AK, Jackler RK, Sweetow RW, Lynch ED, Raventós H, Morrow J, King MC, León PE. Further characterization of the DFNA1 audiovestibular phenotype. *Arch Otolaryngol Head Neck Surg* 1998;124:699-702
- 42 van Wijk E, Krieger E, Kemperman MH, de Leenheer EMR, Huygen PLM, Cremers CWRJ, Cremers FPM, Kremer H. A mutation in the gamma actin 1 (*ACTG1*) gene causes autosomal dominant hearing loss (DFNA20/26). *J Med Genet* 2003;40:879-884.
- 43 Jovine L, Park J, Wassarman PM. Sequence similarity between stereocilin and otoancorin points to a unified mechanism for mechanotransduction in the mammalian inner ear. *BMC Cell Biol* 2002;3:28-32.
- 44 Varga R, Kelley PM, Keats BJ, Starr A, Leal SM, Cohn E, Kimberling WJ. Non-syndromic recessive auditory neuropathy is the result of mutations in the otoferlin (*OTOF*) gene. *J Med Genet* 2003;40:45-50
- 45 Liu XZ, Ouyang XM, Xia XJ, Zheng J, Pandya A, Li F, Du LL, Welch KO, Petit C, Smith RJH, Webb BT, Yan D, Arnos KS, Corey D, Dallos P, Nance WE, Chen ZY. Prestin, a cochlear motor protein, is defective in non-syndromic hearing loss. *Hum Mol Genet* 2003;12 1155-1162.
- 46 Boëda B, El-Amraoui A, Bahloul A, Goodyear R, Daviet L, Blanchard S, Perfettini I, Fath KR, Shorte S, Reiners J, Houdusse A, Legrain P, Wolfrum U, Richardson G, Petit C. Myosin VIIa, harmonin and cadherin 23, three Usher I gene products that cooperate to shape the sensory hair cell bundle. *EMBO* 2002;21 6689-6699
- 47 Weil D, El-Amraoui A, Masmoudi S, Mustapha M, Kikkawa Y, Laine S, Delmaghani S, Adato A, Nadifi S, Zina ZB, Hamel C, Gal A, Ayadi H, Yonekawa H, Petit C. Usher syndrome type I G (USH1G) is caused by mutations in the gene encoding SANS, a protein that associates with the USH1C protein, harmonin. *Hum Mol Genet* 2003;12 463-471

- 48 Weil D, Blanchard S, Kaplan J, Guilford P, Gibson F, Walsh J, Mburu P, Varela A, Leveilliers J, Weston MD, Kelley PM, Kimberling WJ, Wagenaar M, Levi-Acobas F, Larget-Piet D, Munnich A, Steel KP, Brown SD, Petit C. Defective myosin VIIa responsible for Usher syndrome type 1B. *Nature* 1995;374:60-61.
- 49 Tamagawa Y, Ishikawa K, Ishikawa K, Ishida T, Kitamura K, Makino S, Tsuru T, Ichimura K. Phenotype of DFNA11: a nonsyndromic hearing loss caused by a myosin VIIA mutation. *Laryngoscope* 2002;112:292-297.
- 50 Liu XZ, Walsh J, Mburu P, Kendrick-Jones J, Cope MJ, Steel KP, Brown SD. Mutations in the myosin VIIA gene cause non-syndromic recessive deafness. *Nat Genet* 1997;16:188-190.
- 51 Weil D, Kussel P, Blanchard S, Levy G, Levi-Acobas F, Drira M, Ayadi H, Petit C. The autosomal recessive isolated deafness, DFNB2, and the Usher 1B syndrome are allelic defects of the myosin VIIA gene. *Nat Genet* 1997;16:191-193.
- 52 Hasson T, Heintzelman MB, Santos-Sacchi J, Corey DP, Mooseker MS. Expression in cochlea and retina of myosin VIIa, the gene product defective in Usher syndrome type 1B. *Proc Natl Acad Sci* 1995;92:9815-9819.
- 53 Redowicz MJ. Myosins and deafness. *J Muscle Res Cell Motil* 1999;20:241-248.
- 54 Kros CJ, Marcotti W, van Netten SM, Self TJ, Libby RT, Brown SDM, Richardson GP, Steel KP. Reduced climbing and increased slipping adaptation in cochlear hair cells of mice with *Myo7a* mutations. *Nat Neurosci* 2002;5:43-47.
- 55 Hasson T, Heintzelman MB, Santos-Sacchi J, Corey DP, Mooseker MS. Expression in cochlea and retina of myosin VIIa, the gene product defective in Usher syndrome type 1B. *Proc Natl Acad Sci* 1995;92:9815-9819.
- 56 El-Amraoui A, Sahly I, Picaud S, Sahel J, Abitbol M, Petit C. Human Usher 1B/mouse *shaker-1*: the retinal phenotype discrepancy explained by the presence/absence of myosin VIIa in the photoreceptor cells. *Hum Mol Genet* 1996;5:1171-1178.
- 57 Liu X, Vansant G, Udovichenko IP, Wolfrum U, Williams DS. Myosin VIIa, the product of the Usher 1B syndrome gene, is concentrated in the connecting cilia of photoreceptor cells. *Cel Motil Cytoskeleton* 1997;37:240-252.
- 58 El-Amraoui A, Schonh J-S, Kussel-Andermann P, Blanchard S, Desnos C, Henry J-P, Wolfrum U, Darchen F, Petit C. MyRIP, a novel RAB effector, enables myosin VIIa recruitment to retinal melanosomes. *EMBO Rep* 2002;3:463-470.
- 59 Gibbs D, Kitamoto J, Williams DS. Abnormal phagocytosis by retinal pigmented epithelium that lacks myosin VIIa, the Usher syndrome 1B protein. *Proc Natl Acad Sci* 2003;100:6481-6486.
- 60 Liu X, Ordek B, Williams DS. Mutant myosin VIIa causes defective melanosome distribution in the RPE of shaker-1 mice. *Nat Genet* 1998;19:117-118.
- 61 Verpy E, Leibovici M, Zwaenepoel I, Liu X-Z, Gal A, Salem N, Mansour A, Blanchard S, Kobayashi I, Keats BJB, Slim R, Petit C. A defect in harmonin, a PDZ domain-containing protein expressed in the inner ear sensory hair cells, underlies Usher syndrome type 1C. *Nat Genet* 2000;26:51-55.
- 62 Bitner-Glindzicz M, Lindley KJ, Rutland P, Blaydon D, Smith VV, Milla PJ, Hussain K, Furth-Lavi J, Cosgrove KE, Shepherd RM, Barnes PD, O'Brien RE, Farndon PA, Sowden J, Liu X-Z, Scanlan MJ, Malcolm S, Dunne MJ, Aynsley-Green A, Glaser B. A recessive contiguous gene deletion causing infantile hyperinsulinism, enteropathy and deafness identifies the Usher type 1C gene. *Nat Genet* 2000;26:56-60.
- 63 Zwaenepoel I, Verpy E, Blanchard S, Meins M, Apfelstedt-Sylla E, Gal A, Petit C. Identification of three novel mutations in the USH1C gene and identification of thirty-one polymorphisms used for haplotype analysis. *Hum Mut* 2001;17:34-41.
- 64 Blaydon DC, Mueller RF, Hutchin TP, Leroy BP, Bhattacharya SS, Bird AC, Malcolm S, Bitner-Glindzicz M. The contribution of USH1C mutations to syndromic and non-syndromic deafness in the UK. *Clin Genet* 2003;63:303-307.
- 65 Siemens J, Kazmierczak P, Reynolds A, Sticker M, Littlewood-Evans A, Muller U. The Usher syndrome proteins cadherin 23 and harmonin form a complex by means of PDZ-domain interactions. *Proc Natl Acad Sci* 2002;99:14946-14951.
- 66 Bork JM, Peters LM, Riazuddin S, Bernstein SL, Ahmed ZM, Ness SL, Polomeno R, Ramesh A, Schloss M, Srisailpathy CR, Wayne S, Bellman S, Desmukh D, Ahmed Z, Khan SN, Kaloustian VM, Li XC, Lalwani A, Riazuddin S, Bitner-Glindzicz M, Nance WE, Liu XZ, Wistow G, Smith RJ, Griffith AJ, Wilcox ER, Friedman TB, Morell RJ. Usher syndrome 1D and nonsyndromic autosomal recessive deafness DFNB12 are caused by allelic mutations of the novel cadherin-like gene CDH23. *Am J Hum Genet* 2001;68:26-37.

- 67 Bolz H, von Brederlow B, Ramirez A, Bryda EC, Kutsche K, Nothwang HG, Seeliger M, del C-Salcedo Cabrera M, Vila MC, Molina OP, Gal A, Kubisch C Mutation of *CDH23*, encoding a new member of the cadherin gene family, causes Usher syndrome type 1D. *Nat Genet* 2001;27:108-112.
- 68 Astuto LM, Bork JM, Weston MD, Askew JW, Fields RR, Orten DJ, Ohliger SJ, Riazuddin S, Morell RJ, Khan S, Riazuddin S, Kremer H, van Hauwe P, Moller CG, Cremers CWRJ, Ayuso C, Heckenlively JR, Rohrschneider K, Spandau U, Greenberg J, Ramesar R, Reardon W, Bitoun P, Millan J, Legge R, Friedman TB, Kimberling WJ *CDH23* mutation and phenotype heterogeneity: a profile of 107 diverse families with Usher syndrome and nonsyndromic deafness. *Am J Hum Genet* 2002;71:262-275.
- 69 de Brouwer APM, Pennings RJE, Roeters M, Van Hauwe P, Astuto LM, Hoefsloot LH, Huygen PLM, van den Helm B, Deutman AF, Bork JM, Kimberling WJ, Cremers FPM, Cremers CWRJ, Kremer H Mutations in the calcium-binding motifs of *CDH23* and the 35delG mutation in *GJB2* cause hearing loss in one family. *Hum Genet* 2003;112:156-163.
- 70 Liu X-Z, Blanton SH, Bitner-Glindzicz M, Pandya A, Ianda B, Mac-Ardle B, Rajput K, Bellman S, Webb BT, Ping X, Smith RJH, Nance WE Haplotype analysis of the *USH1D* locus and genotype-phenotype correlations. *Clin Genet* 2001;60:58-62.
- 71 Pennings RJE, Topsakal V, Astuto L, de Brouwer APM, Wagenaar M, Huygen PLM, Kimberling WJ, Deutman AF, Kremer H, Cremers CWRJ. Variable clinical features in patients with *CDH23* mutations (*USH1d-DFNB12*). *Otol Neurotol* 2004 conditionally accepted.
- 72 von Brederlow B, Bolz H, Janecke A, La O Cabrera A, Rudolph G, Lorenz B, Schwinger E, Gal A. Identification and in vitro expression of novel *CDH23* mutations of patients with Usher syndrome type 1D. *Hum Mutat* 2002;19:268-273.
- 73 Di Palma F, Holme RH, Bryda EC, Belyantseva IA, Pellegrino R, Kachar B, Steel KP, Noben-Trauth K Mutations in *Cdh23*, encoding a new type of cadherin, cause stereocilia disorganization in waltzer, the mouse model for Usher syndrome type 1D. *Nat Genet* 2001;27:103-107.
- 74 Ahmed ZM, Riazuddin S, Bernstein SL, Ahmed Z, Khan S, Griffith AJ, Morell RJ, Friedman TB, Riazuddin S, Wilcox ER Mutations of the protocadherin gene *PCDH15* cause Usher syndrome type 1F. *Am J Hum Genet* 2001;69:25-34.
- 75 Alagramam KN, Yuan H, Kuehn MH, Murcia CL, Wayne S, Srisailpathy CR, Lowry RB, Knaus R, Van Laer L, Bernier FP, Schwartz S, Lee C, Morton CC, Mullins RF, Ramesh A, Van Camp G, Hageman GS, Woychik RP, Smith RJ, Hageman GS. Mutations in the novel protocadherin *PCDH15* cause Usher syndrome type 1F. *Hum Mol Genet* 2001;10:1709-1718.
- 76 Murcia CL, Woychik RP. Expression of *Pcdh15* in the inner ear, nervous system and various epithelia of the developing embryo. *Mech Dev* 2001;105:163-166.
- 77 Alagramam KN, Murcia CL, Kwon HY, Pawlowski KS, Wright CG, Woychik RP. The mouse Ames waltzer hearing loss-mutant is caused by mutation of *Pcdh15*, a novel protocadherin gene. *Nat Genet* 2001;27:99-102.
- 78 Kikuchi T, Kimura RS, Paul DL, Takasaka T, Adams JC Gap junction systems in the mammalian cochlea. *Brain Res Brain Res Rev* 200;32:163-166.
- 79 Wangemann P K<sup>+</sup> cycling and its regulation in the cochlea and the vestibular labyrinth. *Audiol Neurootol* 2002;7:19-205.
- 80 Kemperman MH, Hoefsloot LH, Cremers CWRJ Hearing loss and connexin 26. *J R Soc Med* 2002;95:171-177.
- 81 Pennings RJE, Huygen PLM, Van Camp G, Cremers CWRJ. A review of progressive phenotypes in nonsyndromic autosomal dominant hearing impairment. *Audiol Med* 2003;1:47-55.
- 82 Tyson J, Tranebjaerg L, Bellman S, Wren C, Taylor J, Bathen J, Aslaksen B, Sorland SJ, Lund O, Malcolm S, Pembrey M, Bhattacharya S, Bitner-Glindzicz M. *ISK* and *KvLQT1* mutation in either of the two components of the delayed rectifier potassium channel can cause the Jervell and Lange-Nielsen syndrome. *Am J Hum Genet* 1997;61:A349.
- 83 Campbell C, Cucci RA, Prasad S, Green GE, Edeal JB, Galer CE, Karniski LP, Sheffield VC, Smith RJH Pendred syndrome, *DFNB4*, and *PDS/SLC26A4* identification of eight novel mutations and possible genotype-phenotype correlations. *Hum Mutat* 2001;17:403-411.
- 84 Stinckens C, Huygen PLM, Joosten FBM, Van Camp G, Otten B, Cremers CWRJ Fluctuant, progressive hearing loss in three patients with the Pendred syndrome. *Int J Ped Otorhinolaryngol* 2001;61:207-215.
- 85 Luxon LM, Cohen M, Coffey RA, Phelps PD, Britton KE, Jan H, Trembath RC, Reardon W. Neurological findings in Pendred syndrome. *Int J Audiol* 2003;42:82-88.
- 86 Scott DA, Wang R, Kreman TM, Sheffield VC, Karniski LP The Pendred syndrome gene encodes a chloride-iodide transport protein. *Nat Genet* 1999;21:440-443.
- 87 Labay V, Raz T, Baron D, Mandel H, Williams H, Barrett T, Szargel R, McDonald L, Shalata A, Nosaka K, Gregory S, Cohen N Mutations in *SLC19A2* cause thiamine-responsive megaloblastic anaemia associated with diabetes mellitus and deafness. *Nat Genet* 1999;22:300-304.

- 88 Wilcox ER, Burton QL, Naz S, Riazuddin S, Smith TN, Ploplis B, Belyantseva I, Ben-Yosef T, Liburd NA, Morell RJ, Kachar B, Wu DK, Griffith AJ, Riazuddin S, Friedman TB Mutations in the gene encoding tight junction claudin-14 cause autosomal recessive deafness *DFNB29* *Cell* 2001;104 165-172
- 89 Karet FE, Finberg KE, Nelson RD, Nayir A, Mocan H, Sanjad SA, Rodriguez-Soriano J, Santos F, Cremers CWRJ, Di Pietro A, Hoffbrand BI, Winiarski J, Bakkaloglu A, Ozen S, Dununsel R, Goodyer P, Jha V, Lifton RP Mutations in the gene encoding B1 subunit of H<sup>+</sup>-ATPase cause renal tubular acidosis with sensorineural deafness *Nat Genet* 1999;21 84-90
- 90 Birkenhäger R, Otto E, Schürmann MJ, Vollmer M, Ruf E-M, Maier-Lutz I, Beekmann F, Fekete A, Omran H, Feldmann D, Milford DV, Jeck N, Konrad M, Landau D, Knoers NVAM, Antignac C, Sudbrak R, Kispert A, Hildebrandt F. Mutation of *BSND* causes Bartter syndrome with sensorineural deafness and kidney failure *Nat Genet* 2001;29:310-314
- 91 Estévez R, Boettger T, Stein V, Birkenhager R, Otto E, Hildebrandt F, Jentsch TJ Barttin is a Cl channel  $\beta$ -subunit crucial for renal Cl reabsorption and inner ear K<sup>+</sup> secretion. *Nature* 2001;414 558-561
- 92 Mueller RF, Young ID. Emery's elements of medical genetics, eleventh edition London Harcourt Publishers Ltd 2001.
- 93 de Kok YJM, van der Maarel SM, Bitner-Glindzicz M, Huber I, Monaco AP, Malcolm S, Pembrey ME, Ropers HH, Cremers FPM Association between X-linked mixed deafness and mutations in the POU domain gene *POU3F4* *Science* 1995;267:685-688.
- 94 Cremers CWRJ, Snik AFM, Huygen PLM, Joosten FBM, Cremers FPM X-linked mixed deafness syndrome with congenital fixation of the stapedial footplate and perilymphatic gusher (*DFN3*) In Cremers CWRJ, Smith RJH (eds) Genetic hearing impairment Its clinical presentations *Advances in Oto-Rhino-Laryngology*, vol 61 Basel Karger, 2002;61:161-167.
- 95 Vahava O, Morell R, Lynch ED, Weiss S, Kagan ME, Ahituv N, Morrow JE, Lee MK, Skvorak AB, Morton CC, Blumenfeld A, Frydman M, Friedman TB, King M-C, Avraham KB Mutation in transcription factor *POU4F3* associated with inherited progressive hearing loss in humans *Science* 1998;279 1950-1954
- 96 Newton VE. Clinical features of the Waardenburg syndromes In Cremers CWRJ, Smith RJH (eds) Genetic hearing impairment Its clinical presentations. *Advances in Oto-Rhino-Laryngology*, vol 61 Basel: Karger, 2002;61:201-208
- 97 Tassabehji M, Read AP, Newton VE, Harris R, Balling R, Gruss P, Strachan T Waardenburg's syndrome patients have mutations in the human homologue of the PAX-3 paired box gene *Nature* 1992;355 635-636
- 98 Tassabehji M, Newton VE, Read AP Waardenburg syndrome type 2 caused by mutations in the human microphthalmia (*MITF*) gene *Nat Genet* 1994;8 251-255.
- 99 Sánchez-Martín M, Rodríguez-García A, Pérez-Losada J, Sagrera A, Read AP, Sánchez-García I *SLUG* (*SNAIL2*) deletions in patients with Waardenburg disease *Hum Mol Genet* 2002;11 3231-3236
- 100 Pingault V, Bondurand N, Kuhlbrodt K, Goerich DE, Preho MO, Puliti A, Herbarth B, Hermans Borgmeyer I, Legius E, Matthijs G, Amiel J, Lyonnet S, Ceccherini I, Romeo G, Smith JC, Read AP, Wegner M, Goossens M. *SOX10* mutations in patients with Waardenburg-Hirschsprung disease *Nat Genet* 1998;18:171-173
- 101 Ederly P, Attie T, Amiel J, Pelet A, Eng C, Hofstra RM, Martelli H, Bidaud C, Munnich A, Lyonnet S Mutation of the endothelin-3 gene in the Waardenburg syndrome-Hirschsprung (Shah-Waardenburg syndrome) *Nat Genet* 1996;12 442-444
- 102 Attie T, Till M, Pelet A, Amiel J, Ederly P, Boutrand L, Munnich A, Lyonnet S. Mutation of the endothelin-receptor B gene in Waardenburg-Hirschsprung disease *Hum Mol Genet* 1995;4:2407-2409
- 103 Hoth CF, Milunsky A, Lipsky N, Sheffer R, Clarren SK, Baldwin CT Mutations in the paired domain of the human PAX3 gene cause Klein-Waardenburg syndrome (WS-III) as well as Waardenburg syndrome type I (WS-I). *Am J Hum Genet* 1993;52:455-462
- 104 Watanabe A, Takeda K, Ploplis B, Tachibana M. Epistatic relationship between Waardenburg syndrome genes *MITF* and *PAX3* *Nat Genet* 1998;18 283-286
- 105 Abdelhak S, Kalatzis V, Heilig R, Compain S, Samson D, Vincent C, Weil D, Cruaud C, Sahly I, Leibovici M, Bitner-Glindzicz M, Francis M, Lacombe D, Vigneron J, Charachon R, Boven K, Bedbeder P, Van Regemorter N, Weissenbach J, Petit C. A human homologue of the *Drosophila* eyes absent gene underlies branchio-oto-renal (BOR) syndrome and identifies a novel gene family *Nat Genet* 1997;15:157-164
- 106 Vincent C, Kalatzis V, Abdelhak S, Chaib H, Compain S, Helias J, Vaneeclo FM, Pett C BOR and BO syndromes are allelic defects of *EYA1*. *Eur J Hum Genet* 1997;5:242-246
- 107 Kemperman MH, Stinckens C, Kumar S, Joosten FBM, Huygen PLM, Cremers CWRJ. The Branchio-Oto-Renal Syndrome In: Cremers CWRJ, Smith RJH (eds) Genetic hearing impairment. Its clinical presentations. *Advances in Oto-Rhino-Laryngology*, vol 61 Basel. Karger, 2002;61:192-200.

- 108 Stinckens C, Standaert L, Casselman JW, Huygen PLM, Kumar S, Van de Wallen J, Cremers CWRJ The presence of a widened vestibular aqueduct and progressive sensorineural hearing loss in the branchio-oto-renal syndrome. A family study. *Int J Pediatr Otorhinolaryngol* 2001;59:163-172
- 109 Kemperman MH, Stinckens C, Kumar S, Huygen PLM, Joosten FB, Cremers CWRJ Progressive fluctuant hearing loss, enlarged vestibular aqueduct, and cochlear hypoplasia in branchio-oto-renal syndrome. *Otol Neurotol* 2001;22:637-643
- 110 Kohlhase J, Wischermann A, Reichenbach H, Froster U, Engel W. Mutations in the SALL1 putative transcription factor gene cause Townes-Brocks syndrome. *Nat Genet* 1998;18:81-83
- 111 Van Esch H, Groenen P, Nesbit MA, Schuffenhauer S, Lichtner P, Vanderlinden G, Harding B, Beetz R, Bilous RW, Holdaway I, Shaw NJ, Fryns J-P, Van de Ven W, Thakker RV, Devriendt K. GATA3 haplo-insufficiency causes human HDR syndrome. *Nature* 2000;406:419-423.
- 112 Verhoeven K, Van Laer L, Kirschhofer K, Legan PK, Hughes DC, Schattman I, Verstreken M, Van Hauwe P, Coucke P, Chen A, Smuth RJH, Somers T, Offeciers FE, Van de Heyning H, Richardson GP, Wachtler F, Kimberling WJ, Willems PJ, Govaerts PJ, Van Camp G. Mutations in the human alfa-tectorin gene cause autosomal dominant non-syndromic hearing impairment. *Nat Genet* 1998;19:60-62
- 113 Mustapha M, Weil D, Chardenoux S, Elias S, El-Zir E, Beckmann JS, Loiselet J, Petit C. An  $\alpha$ -tectorin gene defect causes a newly identified autosomal recessive form of sensorineural pre-lingual non-syndromic deafness, DFNB21. *Hum Mol Genet* 1999;8:409-412
- 114 Iwasaki S, Harada D, Usami S-I, Nagura M, Takeshita T, Hoshino T. Association of clinical features with mutation of *TECTA* in a family with autosomal dominant hearing loss. *Arch Otolaryngol Head Neck Surg* 2002;128:913-917.
- 115 Stickler GB, Belau PG, Farrell FJ, Jones JD, Pugh DG, Steinberg AG, Ward LE. Hereditary progressive arthro-ophthalmopathy. *Mayo Clin Proc* 1965;40:433-455
- 116 Stickler GB, Pugh DG. Hereditary progressive arthro-ophthalmopathy. II. Additional observations on vertebral abnormalities, a hearing defect, and a report of a similar case. *Mayo Clin Proc* 1967;42:495-500
- 117 Hall J. Stickler syndrome. Presenting as a syndrome of cleft palate, myopia and blindness inherited as a dominant trait. *Birth Defects Orig Artic Ser* 1974;10/8:157-171
- 118 Admiraal RJC, Szymko YM, Griffith AJ, Brunner HG, Huygen PLM. Hearing impairment in Stickler syndrome. In: Cremers CWRJ, Smith RJH (eds.) Genetic hearing impairment. Its clinical presentations. *Advances in Oto-Rhino-Laryngology*, vol 61. Basel: Karger, 2002;61:216-223.
- 119 De Leenheer EMR, McGuirt WT, Kunst HPM, Huygen PLM, Smith RJH, Cremers CWRJ. The phenotype of DFNA13/*COL11A2*. In: Cremers CWRJ, Smith RJH (eds.) Genetic hearing impairment. Its clinical presentations. *Advances in Oto-Rhino-Laryngology*, vol 61. Basel: Karger, 2002;61:85-91.
- 120 Pescucci C, Longo I, Bruthini M, Mari F, Renieri A. Type-IV collagen related diseases. *J Nephrol* 2003;16:314-316.
- 121 Kashtan CE. Alport syndrome. An inherited disorder of renal, ocular, and cochlear basement membranes. *Medicine* 1999;78:338-360
- 122 Robertson NG, Lu L, Heller S, Merchant SN, Eavey RD, McKenna M, Nadol JB, Miyamoto RT, Linthicum FH, Lubianca Neto JF, Hudspeth AJ, Seidman CE, Morton CC, Seidman JG. Mutations in a novel cochlear gene cause DFNA9, a human nonsyndromic deafness with vestibular dysfunction. *Nat Genet* 1998;20:29-303
- 123 Robertson NG, Resendes BL, Lin JS, Lee C, Aster JC, Adams JC, Morton CC. Inner ear localization of mRNA and protein products of *COCH*, mutated in the sensorineural deafness and vestibular disorder DFNA9. *Hum Mol Genet* 2001;10:2493-2500
- 124 Robertson NG, Hamaker SA, Patrub V, Aster JC, Morton CC. Subcellular localisation, secretion, and posttranslational processing of normal cochlin, and of mutants causing the sensorineural deafness and vestibular disorder, DFNA9. *J Med Genet* 2003;40:479-486
- 125 Grabski R, Szul T, Sasaki T, Timpl R, Mayne R, Hicks B, Sztul E. Mutations in *COCH* that result in non-syndromic autosomal dominant deafness (DFNA9) affect matrix deposition of cochlin. *Hum Genet* 2003;113:406-416.
- 126 Eudy JD, Weston MD, Yao S, Hoover DM, Rehm HL, Ma-Edmonds M, Yan D, Ahmad I, Cheng JJ, Ayuso C, Cremers C, Davenport S, Moller C, Talmadge CB, Beisel KW, Tamayo M, Morton CC, Swaroop A, Kimberling WJ, Sumegi J. Mutation of a gene encoding a protein with extracellular matrix motifs in Usher syndrome type IIa. *Science* 1998;280:1753-1757.
- 127 Hmani M, Ghorbel A, Bouhila-Elgaied A, Ben Zina Z, Kammoun W, Drira M, Chaabouni M, Petit C, Ayadi H. A novel locus for Usher syndrome type II, *USH2B*, maps to chromosome 3 at p23-24.2. *Eur J Hum Genet* 1999;7:363-367
- 128 Kimberling WJ, Weston MD, Moller C, van Aarem A, Cremers CWRJ, Sumegi J, Ing PS, Connolly C, Martini A, Milani M, Tamayo ML, Bernal J, Greenberg J, Ayuso C. Gene mapping of Usher syndrome

- type IIa: localization of the gene to a 2.1 cM segment on chromosome 1q41 *Am J Hum Genet* 1995;56:216-223.
- 129 Pieke-Dahl S, Moller CG, Kelley PM, Astuto LM, Cremers CWRJ, Gorin MB, Kimberling WJ. Genetic heterogeneity of Usher syndrome type II: localisation to chromosome 5q. *J Med Genet* 2000;37:256-262
- 130 Bhattacharya G, Miller C, Kimberling WJ, Jablonski MM, Cosgrove D. Localization and expression of usherin: a novel basement membrane protein defective in people with Usher's syndrome type IIa. *Hear Res* 2002;163:1-11.
- 131 Pearsall N, Bhattacharya G, Wisecarver J, Adams J, Cosgrove D, Kimberling WJ. Usherin expression is highly conserved in mouse and human tissues. *Hear Res* 2002;174:55-63
- 132 Huang D, Eudy JD, Uzvolgyi E, Davis JR, Talmadge CB, Pretto D, Weston MD, Lehman JE, Zhou M, Seemayer TA, Ahmad I, Kimberling WJ, Sumegi J. Identification of the mouse and rat orthologs of the gene mutated in Usher syndrome type IIa and the cellular source of *USH2A* mRNA in retina, a target tissue of the disease. *Genomics* 2002;80:195-203
- 133 Gorlin RJ, Toniello HV, Cohen MM. Hereditary hearing loss and its syndromes. Oxford: Oxford University Press, 1995
- 134 Chen ZY, Battinelli EM, Fielder A, Boney S, Sims K, Breakefield XO, Craig IW. A mutation in the Norrie disease gene (NDP) associated with X-linked familial exudative vitreoretinopathy. *Nat Genet* 1993;5:180-183.
- 135 Rehm HL, Zhang D-S, Brown MC, Burgess B, Halpin C, Berger W, Morton CC, Corey DP, Chen Z-Y. Vascular defects and sensorineural deafness in a mouse model of Norrie disease. *J Neurosci* 2002;22:4286-4292.
- 136 Lee H-O, LeVorse JM, Shin MK. The endothelin receptor-B is required for the migration of neural crest-derived melanocyte and enteric neuron precursors. *Devel Biol* 2003;259:162-175
- 137 Jin H, May M, Tranebjærg L, Kendall E, Fontan G, Jackson J, Subramony SH, Arena F, Lubbs H, Smith S, Stevenson R, Schwartz C, Vetrie D. A novel X-linked gene, DDP, shows mutations in families with deafness (DFN-1), dystonia, mental deficiency and blindness. *Nat Genet* 1996;14:177-180
- 138 Tranebjærg L, Schwartz C, Eriksen H, Andreasson S, Ponjavic V, Dahl A, Stevenson RE, May M, Arena F, Barker D. A new X-linked recessive deafness syndrome with blindness, dystonia, fractures, and mental deficiency is linked to Xq22. *J Med Genet* 1995;32:257-263.
- 139 Koehler CM, Leuenberger D, Merchant S, Renold A, Junne T, Schatz G. Human deafness dystonia syndrome is a mitochondrial disease. *Proc Natl Acad Sci* 1999;96:2141-2146.
- 140 Wallace DC, Murdock DG. Mitochondria and dystonia: The movement disorder connection? *Proc Natl Acad Sci* 1999;96:1817-1819
- 141 Van Laer L, Huizing EH, Verstreken M, van Zuijlen D, Wauters JG, Bossuyt PJ, Van de Heyning P, McGuirt WT, Smith RJH, Willems PJ, Legan PK, Richardson GP, Van Camp G. Nonsyndromic hearing impairment is associated with a mutation in *DFNA5*. *Nat Genet* 1998;20:194-197
- 142 Cryns K, Thys S, Van Laer L, Oka Y, Pfister M, Van Nassauw L, Smith RJH, Timmermans J-P, Van Camp G. The *WFS1* gene, responsible for low frequency sensorineural hearing loss and Wolfram syndrome, is expressed in a variety of inner ear hair cells. *Histochem Cell Biol* 2003;119:247-256
- 143 Joensuu T, Hamäläinen R, Yuan B, Johnson C, Tegelberg S, Gasparini P, Zelante L, Pirvola U, Pakarinen L, Lehesjoki A-E, de la Chapelle A, Sankila E-M. Mutations in a novel gene with transmembrane domains underlie Usher syndrome type 3. *Am J Hum Genet* 2001;69:673-684
- 144 Adato A, Vreugde S, Joensuu T, Avidan N, Hamalainen R, Belenkij O, Olender T, Bonne-Tamir B, Ben-Asher E, Espinos C, Millán JM, Lehesjoki A-E, Flannery JG, Avraham KB, Pietrokovski S, Sankila E-M, Beckmann JS, Lancet D. *USH3A* transcripts encode clarin-1, a four-transmembrane-domain protein with a possible role in sensory synapses. *Eur J Hum Genet* 2002;10:339-350
- 145 Fields RR, Zhou G, Huang D, Davis JR, Möller C, Jacobson SG, Kimberling WJ, Sumegi J. Usher syndrome type III: revised genomic structure of the *USH3* gene and identification of novel mutations. *Am J Hum Genet* 2002;71:607-617





## A REVIEW OF PROGRESSIVE PHENOTYPES IN NONSYNDROMIC AUTOSOMAL DOMINANT HEARING IMPAIRMENT

R.J.E. Pennings  
P.L.M. Huygen  
G. Van Camp  
C.W.R.J. Cremers

*Audiological Medicine* 2003;1:47-55



---

## INTRODUCTION

HI is the most common sensory disorder worldwide. Congenital HI, which can be caused by genetic as well as environmental factors, is seen in one of 1,000 newborns.<sup>1</sup> More than 50% of these cases is caused by single gene mutations. Environmental factors play an important role in postlingual HI, but also this type can be caused by mutations in single genes. Autosomal recessive sensorineural HI is the main cause of the more profound, mostly prelingual, types of sensorineural HI, whereas autosomal dominant sensorineural HI is generally characterised by a lesser degree of impairment with, usually, postlingual onset and progression of impairment.<sup>2,3</sup>

At this moment, 40 chromosomal loci (DFNA1-40) and 14 genes (DFNA1/*DIAPH1*, DFNA2/*KCNQ4*, DFNA2/*GJB3*, DFNA3/*GJB2*, DFNA3/*GJB6*, DFNA5/*DFNA5*, DFNA6/14(/38)/*WFS1*, DFNA8/12/*TECTA*, DFNA9/*COCH*, DFNA10/*EYA4*, DFNA11/*MYO7A*, DFNA13/*COL11A2*, DFNA15/*POU4F3*, DFNA17/*MYH9*) are known to be involved in non-syndromic autosomal dominant sensorineural HI.<sup>4</sup> Many of these are described elsewhere in this issue. Despite the broad interest in and the extensive research on the genotypes involved, adequate description of the corresponding phenotypes is often still lacking, or lagging behind.

This review focuses on phenotype features of progressive types of nonsyndromic autosomal dominant sensorineural HI. The loci DFNA1, DFNA2, DFNA4, DFNA5, DFNA6/14(/38), DFNA7, DFNA9, DFNA10, DFNA15, DFNA16, DFNA17, DFNA20/26 and DFNA21 are included. For these loci we created “Age Related Typical Audiograms” (ARTA) that cover the relevant age range and constitute a convenient “fingerprint” characterizing these progressive phenotypes.

ARTA were derived on the basis of our own raw data underlying previous reports, data found in sufficient detail in previous reports, or data based on personal communication (details below). The preparation and analyses of these ARTA are also described in this issue.<sup>5</sup>

Data pertaining to speech recognition performance only included data based on our previously described analyses of %Correct scores, derived from individual monaural performance-intensity plots, using phonetically balanced word lists. Relevant score parameter values were obtained by performing regression analysis

on scores relating to either the patient's age or level of HI, as assessed by the pure tone average at the frequencies 1, 2 and 4 kHz (PTA<sub>1-4</sub> kHz). Details of the analyses can be found in the original reports.

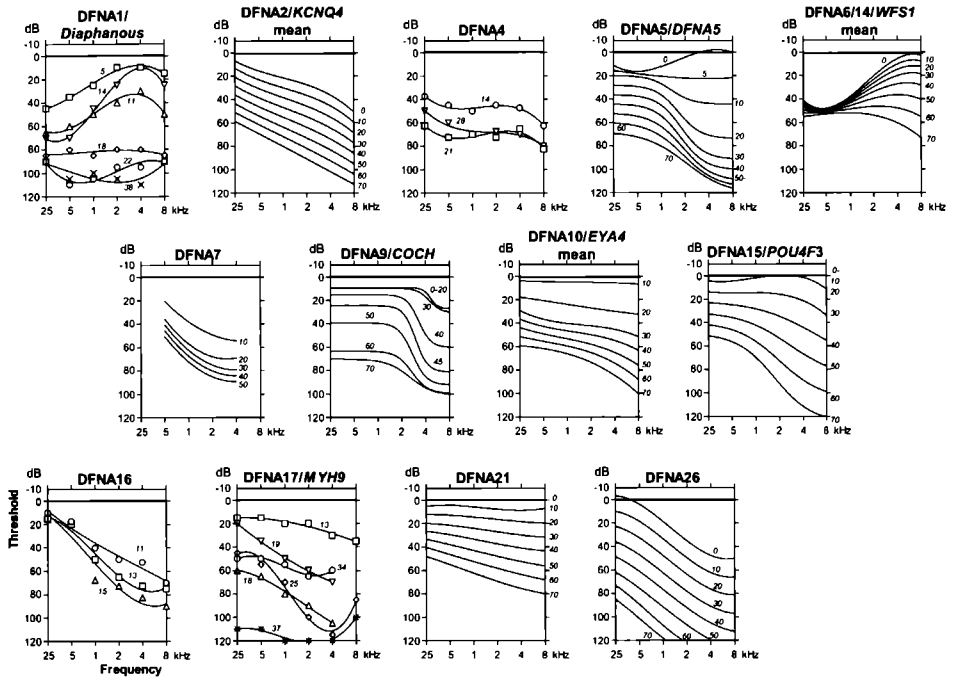

Figure 1. ARTA for DFNA1, DFNA2, DFNA4, DFNA5, DFNA6/14, DFNA7, DFNA9, DFNA15, DFNA16, DFNA17, DFNA20/26 and DFNA21. ARTA derived from single-family data, except when labeled as “mean” (DFNA2, DFNA6/14, DFNA10; as indicated in the text). Italics indicate age (year). Data points are only included when no cross-sectional regression analysis was performed for producing ARTA.

## AGE-RELATED PURE TONE THRESHOLDS

### *Low-frequency sensorineural hearing impairment*

#### DFNA1/DIAPH1

In 1992 León and co-workers identified the first locus for autosomal dominant sensorineural HI on chromosome 5q31.<sup>6</sup> This locus was determined in a large Costa Rican family that traces back to 1754 whose phenotype was already

described in 1981.<sup>7</sup> In 1997 Lynch et al. found DFNA1 to be associated with mutations in the human homologue (*DIAPH1*) of the *Drosophila* gene *diaphanous*.<sup>8</sup> HI began in childhood and initially mainly affected the lower frequencies. Severe progression occurred in the second and third decades of life, involving mid and high frequencies. In adults, hearing loss was profound (up to about 100 dB HL), affecting all frequencies (Figure). Some subjects initially complained about tinnitus. No signs of vestibular dysfunction could be elicited on formal testing.<sup>9</sup>

#### DFNA6/14(/38)/WFS1

Already in 1968 the Vanderbilt University Hereditary Deafness Study Group described a large family characterised by low-frequency sensorineural HI with autosomal dominant inheritance. The locus for this family was designated DFNA6 and mapped to chromosome 4p16.3 in 1995.<sup>10</sup> A third locus (DFNA14) for low-frequency sensorineural HI was mapped close to the DFNA6 region, however, without apparent overlap.<sup>11</sup> Recently, Bespalova et al. described seven DFNA6/14 families to harbour mutations in the *WFS1* gene.<sup>12</sup> A key recombinant in the original American DFNA6 family that excluded the DFNA14 region was in fact based on a phenocopy. Simultaneously, Young et al. identified mutations in *WFS1* within a locus designated DFNA38 that was mapped for a trait with an apparently fairly similar phenotype.<sup>13</sup> The raw data of the American DFNA6 family showed predominant involvement of the 0.25-1 kHz frequencies (Figure). Analysis of these data showed significant progression only at the higher frequencies, however, not beyond presbycusis.<sup>14</sup> The phenotype of the original Dutch DFNA14 family was described by Kunst et al.,<sup>15</sup> who demonstrated the presence of significant progression in sensorineural HI that, however, could be attributed to presbycusis. A second Dutch family was later described (data not shown) that appeared to have significant progression in sensorineural HI, even after correction for presbycusis.<sup>14</sup> Recent findings confirmed progression of sensorineural HI beyond presbycusis (data not shown) in two additional Dutch families.<sup>16</sup>

#### *Flat-threshold sensorineural hearing impairment*

#### DFNA4

In 1995 DFNA4 was introduced as the fourth locus for autosomal dominant inherited sensorineural HI, mapped to chromosome 19q13.<sup>17</sup> Despite an extensive search, the responsible gene is currently still unknown.

The affected persons from this family showed a progressive type of sensorineural HI covering all frequencies (Figure), that was said to be fluctuating, and started in the second decade of life, leading to severe-to-profound hearing loss by the age of 40.

#### DFNA21

DFNA21 is one of the loci whose phenotype was described simultaneously with the results of linkage analysis.<sup>18</sup> Linkage data indicated a position telomeric to the DFNA13 locus on chromosome 6p21-22; the responsible gene is still unknown. The trait showed progressive non-specific mid-frequency sensorineural HI with childhood to late adolescence onset (Figure). Progression of sensorineural HI was fairly similar for all frequencies, with a pooled value of 1.0 dB/year. Oculovestibular function was found to be normal.

#### *High-frequency hearing impairment*

#### DFNA2/*KCNQ4*

At this moment, two deafness genes are known to exist within the DFNA2 region on chromosome 1p34: *KCNQ4* and *GJB3*.<sup>4,19</sup> As yet, only the phenotypes of traits with mutations in *KCNQ4* have been thoroughly described. DFNA2 is linked to the short arm of chromosome 1<sup>20,21</sup> and the responsible gene *KCNQ4* coding for a potassium channel was detected in 1999.<sup>22,23</sup> Several different mutations have been found in different DFNA2/*KCNQ4* families,<sup>22-27</sup> but the fact that one mutation (W276S) has been found repeatedly in different, presumably unrelated families<sup>28,29</sup> suggests the possibility of a hotspot mutation in the *KCNQ4* gene.<sup>30</sup>

DFNA2/*KCNQ4* is generally characterised by a progressive downsloping pure-tone audiogram (Figure) and its phenotype features have been described for several families originating from Belgium, the Netherlands, Japan and the USA by De Leenheer et al.<sup>27</sup> The Figure shows ARTA obtained from averaging the age-related threshold data of 6 DFNA2/*KCNQ4* families,<sup>20,26,28,29,31,32</sup> threshold data communicated personally by Drs Shelley Smith, Margriet Verstreken and Floris Wuyts in 2000 and Zoreh Talebizadeh in 2001 as outlined in Chapter 2.1 of this thesis.<sup>5</sup>

Speech recognition scores of one of the four currently known Dutch DFNA2 families were analysed by De Leenheer et al.<sup>29</sup> Speech recognition was in agreement with pure-tone audiograms and showed no deterioration before the fourth decade. Only after a high level of pure tone sensorineural HI had been

reached, speech recognition started to deteriorate. Bom et al. therefore suggested that relative sparing of outer hair cell function with the associated fine-tuning mechanisms might be held responsible for this finding.<sup>33</sup>

Vestibular hyperreactivity appeared to be present in the two *DFNA2/KCNQ4* families in whom vestibular function has been thoroughly assessed.<sup>28,29</sup> We suggest this can be associated with the expression of (mutated) *KCNQ4* in central vestibular pathways.<sup>34</sup>

#### *DFNA5/DFNA5*

*DFNA5* was mapped to chromosome 7p15 in 1995 and, after refining the locus, Van Laer et al. reported finding the *DFNA5* gene.<sup>35,37</sup> The only currently known *DFNA5* trait occurs in a large Dutch family, its phenotype was described already in the late sixties of the past century.<sup>38-42</sup> The pure tone audiogram showed a Z-shaped configuration (Figure). Onset was determined at between 5 and 15 years of age. Progression was most pronounced in the first three decades of life and then gradually slowed down. Original data were obtained (personal communication by Dr. Egbert Huizing, 2000) and re-analysed by De Leenheer et al.<sup>43</sup> The lower frequencies showed a lower maximum rate of deterioration (1 dB/year) than did the higher frequencies (1-4 dB/year).<sup>3</sup>

Relatively good speech recognition scores were reported by De Leenheer et al.<sup>44</sup> At a given level of sensorineural HI, the scores of the *DFNA5* patients were nearly similar to those reported for *DFNA2/KCNQ4* patients<sup>29</sup> and much better than in *DFNA9*<sup>33</sup> or presbycusis patients.<sup>29</sup> It was speculated that outer hair cell function was relatively well preserved.<sup>44</sup>

Vestibular function was formally tested in four members of one branch of the original *DFNA5* family and found to be normal.<sup>44</sup>

#### *DFNA7*

*DFNA7* has been mapped to chromosome 1q21-23 in one Norwegian family with 22 affected individuals. The responsible gene is not yet known.<sup>45</sup> The trait showed postlingual onset affecting the higher frequencies. The lower frequencies were relatively well preserved (Figure) and a useful hearing capacity was thus maintained until old age. Periods of rapid progression of hearing loss were seen mainly at young ages and could be asymmetrical. All patients had 100% speech recognition unaided and no signs of vestibular dysfunction could be detected on bithermal caloric testing.<sup>46</sup>



### DFNA9/*COCH*

DFNA9/*COCH* is currently the only form of nonsyndromic autosomal dominant sensorineural HI that includes the feature of substantial vestibular impairment<sup>3,47</sup> DFNA9 was found to be linked to chromosome 14q12-q13<sup>48,49</sup> and *COCH* was identified as the gene carrying the disease-causing mutations.<sup>50-54</sup> Previously performed temporal bone studies demonstrated typical histopathological features.<sup>55,56</sup> Several clinical reports antedated the linkage reports on DFNA9/*COCH*.<sup>57-62</sup> The same mutation is found in a number of Western European DFNA9/*COCH* families, probably originating from a single common ancestor.<sup>53</sup> In addition, other mutations have been identified in American and Australian families.<sup>52,63,64</sup> DFNA9 shows a flat to gently downsloping pure tone threshold with limited or no loss in the low-frequency range in the first three to four decades of life, followed by progression establishing downsloping pure tone threshold characteristics and eventually profound deafness with residual hearing only at the lower frequencies (Figure).

Bom et al. evaluated speech recognition scores in DFNA9/*COCH* patients and compared them to scores obtained for patients with DFNA2/*KCNQ4*.<sup>33</sup> DFNA2 and DFNA9 patients at modal ages appeared to have fairly similar pure tone audiograms, but exhibited a substantial difference in speech recognition performance. At a given level of sensorineural HI, the DFNA9 patients showed poorer speech recognition scores than the DFNA2 patients. It was speculated that such differences relate to differences in intracochlear pathology, especially the degree of functional impairment of inner and outer hair cells.<sup>33</sup> Widespread inner-ear pathology is found in the case of DFNA9,<sup>65</sup> which is reflected not only in relatively poor speech recognition performance, but also in the development of vestibular hyporeflexia and, eventually, areflexia.

Typical for DFNA9/*COCH* are the most impressive vestibular findings that have been documented in several families, where the patients developed vestibular hyporeflexia ultimately leading to complete vestibular areflexia from the age of about 40 year onwards.<sup>50,55,57,66-70</sup> Up to now, this is the only DFNA locus associated with vestibular areflexia. In the course of progression, patients may have episodes of Ménière-like symptoms, sometimes associated with vestibular hyperreactivity.<sup>50,55,66,68-70</sup> Presumably, such episodes are associated with transient asymmetry in peripheral vestibular function.<sup>67,69</sup>

#### DFNA10/*EYA4*

In 1996 DFNA10 was mapped to chromosome 6q22.3-23.2 based on linkage analysis results in a large American family.<sup>71</sup> Later refinement was achieved by an additional Belgian family.<sup>72</sup> In 2001, Wayne et al. found mutations in the transcriptional activator *EYA4* to be responsible for DFNA10 in both families.<sup>73</sup> DFNA10 is phenotypically characterised by mid- and high-frequency sensorineural HI progressing mainly during the first few decades of life.<sup>74-76</sup> The ARTA in the Figure is the result of an average of the data pertaining to both currently known families. Presumably, onset was postlingual, as individuals were only affected after having developed normal speech and language assessment. De Leenheer et al. showed that the additional deterioration of sensorineural HI occurring after the age of 30 could not be distinguished from presbycusis.<sup>74</sup> Verstreken et al. reported the presence of tinnitus in 35% of the affected Belgian family members.<sup>76</sup> A thorough phoneme recognition score analysis was also performed and it demonstrated that by the age of 67 years speech recognition is about 50%.<sup>74</sup>

#### DFNA15/*POU4F3*

The responsible gene in an Israeli Jewish family is located at the DFNA15 locus on chromosome 5q31 and is a transcription factor named *POU4F3*.<sup>77</sup> HI in this family, caused by *POU4F3* mutations, was described by Frydman et al.<sup>78</sup> They noticed progressive high-frequency sensorineural HI starting at between 18 and 30 years of age. Pure tone audiograms showed a downsloping configuration and sensorineural HI gradually progressed involving all frequencies (Figure).

#### DFNA16

The DFNA16 locus has been mapped to chromosome 2q23-24.3 and several candidate genes have been suggested to exist by Kasai et al.<sup>79</sup> DFNA16 is characterised by repeated episodes of fluctuating progressive high-frequency sensorineural HI (Figure). Normal hearing anamnestically was present until 9-10 years of age. DFNA16 is the first type of sensorineural HI that appears to respond to steroid treatment; all affected mothers reported having experienced (increased) tinnitus and hearing loss after delivery.<sup>80</sup>

#### DFNA17/*MYH9*

*MYH9* is a nonmuscle-myosin heavy-chain gene that shows mutations in one family linked to DFNA17.<sup>81</sup> This trait is characterised by progressive high-

frequency sensorineural HI that begins at about 10 years of age. Initially, it only involves the higher frequencies, but by the age of 30 years affected individuals have developed severe to profound sensorineural HI at all frequencies (Figure). Histopathological study has identified cochleosaccular degeneration (Scheibe type).<sup>82</sup>

#### DFNA20/26

DFNA20 and DFNA26 have both been mapped to chromosome 17q25. It is very likely that both loci are caused by mutations in the same gene.<sup>4,83</sup> Sensorineural HI in DFNA20 shows relatively late onset and most prominent progression at the high frequencies.<sup>84</sup> The phenotype of a Norwegian family linked to DFNA26 was described in 1968 by Teig (data underlying the ARTA in Figure) and demonstrated primary involvement of the higher frequencies to be present already at young ages and progression with secondary involvement of the lower frequencies.<sup>85</sup>

Table 1 Speech recognition scores for DFNA2, DFNA5, DFNA9 and DFNA10 related to age and HI.

	Speech recognition scores related to:			
	Age (year)		PTA <sub>1-4kHz</sub> (dB HL)	
	Onset age (year)	Deterioration rate (%/year)	Onset level (dB HL)	Deterioration gradient (%/dB HL)
DFNA2/ <i>KCNQ4</i>	34	0.3	65	0.5
DFNA5/ <i>DFNA5</i>	16	0.7	41	0.4
DFNA9/ <i>COCH</i>	43	1.8	45	1.2
DFNA10/ <i>EYA4</i>	43	1.8	53	1.4

Onset age and onset level are related to 90% phoneme recognition score. Deterioration rate and deterioration gradient relate to (average, maximum) slope in score against age and score against PTA<sub>1-4 kHz</sub> plots, respectively. Values for DFNA10 are calculated from the original plots.

## PHONEME RECOGNITION SCORE RELATED TO AGE AND LEVEL OF IMPAIRMENT

As can be seen in the Figure, some similarity in pure tone threshold features (ARTA) exists between DFNA2, DFNA5, DFNA9 and DFNA10. As described in part in the separate sections above, analyses of speech recognition scores (Table) have revealed some intriguing differences between some of these traits.<sup>33,44,74</sup> The low onset age for score deterioration in DFNA5 underlines the rapid deterioration in this trait; onset age for pure tone hearing loss was 5-15 year! However, the rate of score deterioration was relatively low in this trait, not much higher than in

DFNA2 that showed later onset of deterioration in speech recognition (Table 1). Both DFNA9 and DFNA10 showed a relatively late onset of deterioration of speech recognition, then followed by a similar, considerably higher rate of progression than was found in DFNA2 or DFNA5.<sup>44</sup> Both DFNA9 and DFNA10<sup>74</sup> showed a fairly similar development in terms of phoneme recognition score related to the level of sensorineural HI, with a relatively low onset level and a relatively high deterioration gradient. Patients with DFNA5 showed a similar onset level, but a lower, i.e. more favourable, deterioration gradient. A similar relatively low deterioration gradient was found in DFNA2 patients where it was combined, however, with a higher onset level, which indicates that at a similar level of impairment, they showed higher scores than the DFNA5 patients. At comparable levels of HI, DFNA5 patients thus showed speech recognition scores in between those of DFNA9 patients, who had relatively poor scores, and those of DFNA2 patients, who had relatively good scores.<sup>44</sup>

## REFERENCES

- 1 Lalwani AK, Castelein CM Cracking the auditory genetic code: nonsyndromic hereditary hearing impairment *Am J Otol* 1999;20:115-132
- 2 Gorlin RJ, Tonello HV, Cohen MM. Hereditary hearing loss and its syndromes New York Oxford University Press,1995
- 3 Bom SJH, Kunst HPM, Huygen PLM, Cremers FPM, Cremers CWRJ Non-syndromal autosomal dominant hearing impairment ongoing phenotypical characterization of genotypes *Br J Audiol* 1999;33:358-348.
- 4 Van Camp G, Smith RJH Hereditary Hearing Loss Homepage World Wide Web URL: <http://dnalab-www.uia.ac.be/dnalab/hhh/>, accessed December 2001
- 5 Huygen PLM, Pennings RJE, Cremers CWRJ Characterizing and distinguishing progressive phenotypes in nonsyndromic autosomal dominant hearing impairment *Audiol Med* 2003;1:37-46
- 6 Leon PE, Raventos H, Lynch E, Morrow J, King M-C The gene for an inherited form of deafness maps to chromosome 5q31 *Proc Nat Acad Sci* 1992;89 5181-5184
- 7 Léon PE, Bonilla JA, Sánchez JR, Vanegas R, Villalobos M, Torres L, León F, Howell AL, Rodríguez JA Low-frequency hereditary deafness in man with childhood onset. *Am J Hum Genet* 1981;33 209-214
- 8 Lynch ED, Lee MK, Morrow JE, Welsh PL, León PE, King MC. Nonsyndromic deafness DFNA1 associated with mutation of a human homolog of the *Drosophila* gene *diaphanous*. *Science* 1997;278 1315-1318.
- 9 Lalwani AK, Jackler RK, Sweetow RW, Lynch ED, Raventós H, Morrow J, King MC, León PE Further characterization of the DFNA1 audiovestibular phenotype. *Arch Otolaryngol Head Neck Surg* 1998;124 699-702.
- 10 Lesperance MM, Hall JW III, Bess FH, Fukushima K, Jain PK, Ploplis B, San Agustin TB, Skarka H, Smith RJH, Wills M, Wilcox ER A gene for autosomal dominant nonsyndromic hereditary hearing impairment maps to 4p16.3 *Hum Mol Genet* 1995;4:1967-1972
- 11 Van Camp G, Kunst H, Flothmann K, McGuirt W, Wauters J, Marres H, Verstreken M, Bespalova IN, Burmeister M, Van de Heyning PH, Smith RJH, Willems PJ, Cremers CWRJ, Lesperance MM A gene for autosomal dominant hearing impairment (DFNA14) maps to a region on chromosome 4p16.3 that does not overlap the DFNA6 locus. *J Med Genet* 1999;36:532-536.
- 12 Bespalova IN, Van Camp G, Bom SJH, Brown DJ, Cryns K, DeWan AT, Erson AE, Flothmann K, Kunst HPM, Kurnool P, Sivakumaran TA, Cremers CWRJ, Leal SM, Burmeister M, Lesperance MM

- Mutations in the Wolfram syndrome 1 gene (*WFS1*) are a common cause of low frequency sensorineural hearing loss *Hum Mol Genet* 2001;10 2501-2508
- 13 Young T-L, Ives E, Lynch E, Person R, Snook S, MacLaren L, Cator T, Griffin A, Fernandez B, Lee MK, King M-C Non-syndromic progressive hearing loss *DFNA38* is caused by heterozygous missense mutation in the Wolfram syndrome gene *WFS1*. *Hum Mol Genet* 2001;10:2509-2514.
- 14 Huygen PLM, Bom SJH, Van Camp G, Cremers CWRJ The clinical presentation of the *DFNA* loci where causative genes have not yet been cloned. *DFNA4*, *DFNA6/14*, *DFNA7*, *DFNA16*, *DFNA20* and *DFNA21*. In Cremers CWRJ, Smith RJH (eds) Genetic hearing impairment. Its clinical presentations Advances in Oto-Rhino-Laryngology, vol.61. Basel. Karger. 2002, 61 98-106.
- 15 Kunst H, Marres H, Huygen P, Van Camp G, Joosten F, Cremers C Autosomal dominant non-syndromal low-frequency sensorineural hearing impairment linked to chromosome 4p16 (*DFNA14*): statistical analysis of hearing threshold in relation to age and evaluation of vestibulo-ocular functions *Audiology* 1999;38 165-173
- 16 Pennings RJE, Bom SJH, Cryns K, Flothmann K, Huygen PLM, Kremer H, Van Camp G, Cremers CWRJ Low-frequency sensorineural hearing loss (*DFNA6/14/WFS1*) is progressive *Arch Otolaryngol Head Neck Surg* 2003;129:421-426
- 17 Chen AH, Ni L, Fukushima K, Marietta J, O'Neill M, Coucke P, Willems P, Smith RJH Linkage of a gene for dominant non-syndromic deafness to chromosome 19. *Hum Mol Genet* 1995;4:1073-1076
- 18 Kunst H, Marres H, Huygen P, van Duynhoven G, Krebsova A, van der Velde S, Reis A, Cremers F, Cremers C. Non-syndromic autosomal dominant progressive non-specific mid-frequency sensorineural hearing impairment with childhood to late adolescence onset (*DFNA21*) *Clin Otolaryngol* 2000;25 45-54
- 19 Van Hauwe P, Coucke PJ, Declau F, Kunst H, Ensink RJ, Marres HA, Cremers CWRJ, Djelantik B, Smith SD, Kelley P, Van de Heyning PH, Van Camp G. Deafness linked to *DFNA2*: one locus but how many genes? *Nat Genet* 1999;21 263
- 20 Coucke P, Van Camp G, Djoyodiharjo B, Smith SD, Frants RR, Padberg GW, Darby JK, Huizing EH, Cremers CWRJ, Kimberling WJ, Oostra BA, Van de Heyning PH, Willems PJ. Linkage of autosomal dominant hearing loss to the short arm of chromosome 1 in two families *N Engl J Med* 1994;331:425-431.
- 21 Van Camp G, Coucke PJ, Kunst H, Schatteman I, Van Velzen D, Marres H, van Ewijk M, Declau F, Van Hauwe P, Meyers J, Kenyon J, Smith SD, Smith RJH, Djelantik B, Cremers CWRJ, Van de Heyning PH, Willems PJ. Linkage analysis of progressive hearing loss in five extended families maps the *DFNA2* gene to a 1.25-Mb region on chromosome 1p *Genomics* 1997;41:70-74.
- 22 Kubisch C, Schroeder BC, Friedrich T, Lütjohann B, El-Amraoui A, Marlin S, Petit C, Jentsch TJ *KCNQ4*, a novel potassium channel expressed in sensory outer hair cells, is mutated in dominant deafness *Cell* 1999;96 437-446.
- 23 Coucke PJ, Van Hauwe P, Kelley PM, Kunst H, Schatteman I, Van Velzen D, Meyers J, Ensink RJ, Verstreken M, Declau F, Marres H, Kastury K, Bhasin S, McGurrt WT, Smith RJH, Cremers CWRJ, Van de Heyning P, Willems PJ, Smith SD, Van Camp G. Mutations in the *KCNQ4* gene are responsible for autosomal dominant deafness in four *DFNA2* families. *Hum Mol Genet* 1999;8 1321-1328.
- 24 Van Hauwe P, Coucke P, Van Camp G. The *DFNA2* locus for hearing impairment: two genes regulating K<sup>+</sup> ion recycling in the inner ear *Br J Audiol* 1999;33:285-289.
- 25 Van Hauwe P, Coucke PJ, Ensink RJ, Huygen P, Cremers CWRJ, Van Camp G Mutations in the *KCNQ4* K<sup>+</sup> channel gene, responsible for autosomal dominant hearing loss, cluster in the channel pore region. *Am J Med Genet* 2000;93 184-187
- 26 Talebizadeh Z, Kelley PM, Askew JW, Beisel KW, Smith SD Novel mutation in the *KCNQ4* gene in a large kindred with dominant progressive hearing loss *Hum Mutat* 1999;14:493-501
- 27 De Leenheer EMR, Ensink RJH, Kunst HPM Marres HAM, Talebizadeh Z, Declau F, Smith SD, Usami SI, Van de Heyning PH, Van Camp G, Huygen PLM, Cremers CWRJ *DFNA2/KCNQ4* and its manifestations In Cremers CWRJ, Smith RJH (eds) Genetic hearing impairment Its clinical presentations Advances in Oto-Rhino-Laryngology. Basel. Karger, vol 61 2002;61:41-46.
- 28 Marres H, van Ewijk M, Huygen P, Kunst H, Van Camp G, Coucke P, Willems P, Cremers C Inherited nonsyndromic hearing loss. An audiovestibular study in a large family with autosomal dominant progressive hearing loss related to *DFNA2*. *Arch Otolaryngol Head Neck Surg* 1997;123 573-577
- 29 De Leenheer EMR, Huygen PLM, Coucke PJ, Admiraal RJC, Van Camp G, Cremers CWRJ Longitudinal and cross-sectional phenotype analysis in a new, large Dutch *DFNA2/KCNQ4* family. *Ann Otol Rhinol Laryngol* 2002;111:267-274
- 30 Van Camp G, Coucke PJ, Akita J, Fransen E, Abe S, De Leenheer EMR, Huygen PLM, Cremers CWRJ, Usami I A mutational hotspot in the *KCNQ4* gene responsible for autosomal dominant hearing impairment. *Hum Mutat* 2002;20:15-19

- 31 Kunst H, Marres H, Huygen P, Ensink R, Van Camp G, Van Hauwe P, Coucke P, Willems P, Cremers C. Nonsyndromic autosomal dominant progressive sensorineural hearing loss. audiologic analysis of a pedigree linked to DFNA2 *Laryngoscope* 1998;108 74-80
- 32 Ensink RJH, Huygen PLM, Van Hauwe P, Coucke P, Cremers CWRJ, Van Camp G. A Dutch family with progressive sensorineural hearing impairment linked to the DFNA2 region *Eur Arch Otorhinolaryngol* 2000;257:62-67
- 33 Bom SJH, De Leenheer EMR, Lemaire FX, Kemperman MH, Verhagen WIM, Marres HAM, Kunst HPM, Ensink RJH, Bosman AJ, Van Camp G, Cremers FPM, Huygen PLM, Cremers CWRJ. Speech recognition scores related to age and degree of hearing impairment in DFNA2/KCNQ4 and DFNA9/COCH. *Arch Otolaryngol Head Neck Surg* 2001;127 1045-1048.
- 34 Kharkovets T, Hardelin J-P, Safieddine S, Schweizer M, El-Amraoui A, Petit C, Jentsch TJ. KCNQ4, a K<sup>+</sup> channel mutated in a form of dominant deafness, is expressed in the inner ear and the central auditory pathway. *Proc Nat Acad Sci* 2000;97 4333-4338
- 35 Van Camp G, Coucke P, Balemans W, van Velzen D, van de Bilt C, van Laer L, Smith RJH, Fukushima K, Padberg GW, Frants RR, van de Heyning P, Smith SD, Huizing EH, Willems PJ. Localization of a gene for non-syndromic hearing loss (DFNA5) to chromosome 7p15. *Hum Mol Genet* 1995;4 2159-2163
- 36 Van Laer L, Van Camp G, van Zuijlen D, Green ED, Verstreken M, Schatteman I, Van de Heyning P, Balemans W, Coucke P, Greinwald JH, Smith RJH, Huizing E, Willems P. Refined mapping of a gene for autosomal dominant progressive sensorineural hearing loss (DFNA5) to a 2-cM region, and exclusion of a candidate gene that is expressed in the cochlea. *Eur J Hum Genet* 1997;5:397-405
- 37 Van Laer L, Huizing EH, Verstreken M, van Zuijlen D, Wauters JG, Bossuyt PJ, Van de Heyning P, McGuirt WT, Smith RJH, Willems PJ, Legan PK, Richardson GP, Van Camp G. Nonsyndromic hearing impairment is associated with a mutation in DFNA5. *Nat Genet* 1998;20:194-197.
- 38 Huizing EH, Van Bolhuis AH, Odenthal DW. Studies on progressive hereditary perceptive deafness in a family of 335 members. I. Genetical and general audiological results. *Acta Otolaryngol* 1965;61 35-41
- 39 Huizing EH, Van Bolhuis AH, Odenthal DW. Studies on progressive hereditary perceptive deafness in a family of 335 members. II. Characteristic pattern of hearing deterioration. *Acta Otolaryngol* 1965b;61 161-167
- 40 Huizing EH, van den Wijngaart WSIM, Verschuure J. A follow-up study in a family with dominant progressive inner ear deafness. *Acta Otolaryngol* 1983;95:620-626
- 41 van den Wijngaart WSIM, Huizing EH, Niermeijer MF, Verschuure J, Brocaar MP, Blom W. Follow-up study in a family with dominant progressive hereditary sensorineural hearing impairment II. Clinical aspects. *Audiology* 1985;24 336-342.
- 42 van den Wijngaart WSIM, Verschuure J, Brocaar MP, Huizing EH. Follow-up study in a family with dominant progressive hereditary sensorineural hearing impairment. I. Analysis of hearing deterioration. *Audiology*, 1985;24 233-240
- 43 De Leenheer EMR, van Zuijlen DA, Van Laer L, Van Camp G, Huygen PLM, Huizing EH, Cremers CWRJ. Clinical features of DFNA5. In Cremers CWRJ, Smith RJH (eds) *Genetic hearing impairment. Its clinical presentations. Advances in Oto-Rhino-Laryngology*, vol. 61. Basel: Karger. 2002, 61 53-59
- 44 De Leenheer EMR, van Zuijlen DA, Van Laer L, Van Camp G, Huygen PLM, Huizing EH, Cremers CWRJ. Further delineation of the DFNA5 phenotype. Results of speech recognition tests. *Ann Otol Rhinol Laryngol* 2002;111.639-641
- 45 Fagerheim T, Nilssen Ø, Raeymaekers P, Brox V, Moum T, Elverland HH, Teig E, Omland HH, Fostad GK, Tranebjærg L. Identification of a new locus for autosomal dominant non-syndromic hearing impairment (DFNA7) in a large Norwegian family. *Hum Mol Genet* 1996;5:1187-1191
- 46 Elverland HH, Hansen PW, Fagerheim T, Tranebjærg L. Audiological variation in a family with autosomal dominant non-syndromic hearing impairment linked to the DFNA7 locus - a need for reclassification of deafness. *J Audiol Med* 1998;7:109-119.
- 47 Huygen PLM, Verhagen WIM. Peripheral vestibular and vestibulo-ocular dysfunction in hereditary disorders. A review of the literature and a report on some additional findings. *J Vest Res* 1994;4:81-104
- 48 Manolis EN, Yandavi N, Nadol JB Jr, Eavey RD, McKenna M, Rosenbaum S, Khetarpal U, Halpin C, Merchant SN, Duyk GM, MacRae C, Seidman CE, Seidman JG. A gene for non-syndromic autosomal dominant progressive postlingual sensorineural hearing loss maps to chromosome 14q12-13. *Hum Mol Genet* 1996;5:1047-1050
- 49 Robertson NG, Skvorak AB, Yin Y, Weremowicz S, Johnson KR, Kovatch KA, Battey JF, Bieber FR, Morton CC. Mapping and characterization of a novel cochlear gene in human and in mouse. a positional candidate gene for a deafness disorder, DFNA9. *Genomics* 1997;46:345-354.
- 50 Franssen E, Verstreken M, Verhagen WIM, Wuyts FL, Huygen PLM, D'Haese P, Robertson NG, Morton CC, McGuirt WT, Smith RJH, Declau F, Van de Heyning PH, Van Camp G. High prevalence of

- symptoms of Ménière's disease in three families with a mutation in the *COCH* gene Hum Mol Genet 1999;8:1425-1429.
- 51 De Kok YJM, Bom SJH, Brunt TM, Kemperman MH, van Beusekom E, van der Velde-Visser SD, Robertson NG, Morton CC, Huygen PLM, Verhagen WIM, Brunner HG, Cremers CWRJ, Cremers FPM A Pro51Ser mutation in the *COCH* gene is associated with late onset autosomal dominant progressive sensorineural hearing loss with vestibular defects. Hum Mol Genet 1999;8:361-366.
- 52 Robertson NG, Lu L, Heller S, Merchant SN, Eavey RD, McKenna M, Nadol JB Jr, Miyamoto RT, Linthicum FH Jr, Lubianca Neto JF, Hudspeth AJ, Seidman CE, Morton CC, Seidman JG. Mutations in a novel cochlear gene cause DFNA9, a human nonsyndromic deafness with vestibular dysfunction Nat Genet 1998;20:299-303
- 53 Fransen E, Verstreken M, Bom SJH, Lemaire F, Kemperman MH, De Kok YJM, Wuyts FL, Verhagen WIM, Huygen PLM, McGuirt WT, Smith RJH, Van Maldergem L, Declau F, Cremers CWRJ, Van de Heyning PH, Cremers FPM, Van Camp G A common ancestor for *COCH* related cochleovestibular (DFNA9) patients in Belgium and The Netherlands bearing the P51S mutation. J Med Genet 2001;38:61-65
- 54 Fransen E, Van Camp G The *COCH* gene: a frequent cause of hearing impairment and vestibular dysfunction? Br J Audiol 1999;33:297-302
- 55 Khetarpal U, Schuknecht HF, Gacek RR, Holmes LB Autosomal dominant sensorineural hearing loss. Pedigrees, audiologic findings, and temporal bone findings in two kindreds Arch Otolaryngol Head Neck Surg 1991;117:1032-1042
- 56 Khetarpal U. Autosomal dominant sensorineural hearing loss Further temporal bone findings Arch Otolaryngol Head Neck Surg 1993;119:106-108.
- 57 Verhagen WIM, Huygen PLM, Joosten EMG Familial progressive vestibulocochlear dysfunction. Arch Neurol 1988;45:766-768.
- 58 Verhagen WIM, Huygen PLM, Theunissen EJJM, Joosten EMG Hereditary vestibulo-cochlear dysfunction and vascular disorders J Neurol Sci 1989;92:55-63.
- 59 Verhagen WIM, Huygen PLM. Familial progressive vestibulocochlear dysfunction. Arch Neurol 1991;48:262
- 60 Verhagen WIM, Huygen PLM, Bles W. A new autosomal dominant syndrome of idiopathic progressive vestibulo-cochlear dysfunction with middle-age onset. Acta Otolaryngol 1992;112:899-906
- 61 Halpin C, Herrmann B, Whearty M. A family with autosomal-dominant progressive sensorineural hearing loss rehabilitation and counseling Am J Audiol 1996;5:23-32
- 62 Halpin C, Khetarpal U, McKenna M Autosomal-dominant progressive sensorineural hearing loss in a large North American family Am J Audiol 1996;5:105-111
- 63 Kamarinos M, McGill J, Lynch M, Dahl H. Identification of a novel *COCH* mutation, I109N, highlights the similar clinical features observed in DFNA9 families Hum Mutat 2001;17:351-356
- 64 Eavey RD, Manolis EN, Lubianca J, Merchant S, Seidman JG, Seidman C Mutations in *COCH* (formerly *Coch5b2*) cause DFNA9 In: Kitamura K, Steel KP (eds) Genetics in otorhinolaryngology Advances in Oto-Rhino-Laryngology, vol.56 Basel Karger. 2000;56:101-102
- 65 Khetarpal U. DFNA9 is a progressive audiovestibular dysfunction with a microfibrillar deposit in the inner ear. Laryngoscope 2000;110:1379-1384.
- 66 Bom SJH, Kemperman MH, De Kok YJM, Huygen PLM, Verhagen WIM, Cremers FPM, Cremers CWRJ. Progressive cochleovestibular impairment caused by a point mutation in the *COCH* gene at DFNA9. Laryngoscope, 1999;109:1525-1530.
- 67 Verhagen WIM, Bom SJH, Huygen PLM, Fransen E, Van Camp G, Cremers CWRJ. Familial progressive vestibulocochlear dysfunction caused by a *COCH* mutation (DFNA9) Arch Neurol 2000;57:1045-1047.
- 68 Verhagen WIM, Bom SJH, Fransen E, Van Camp G, Huygen PLM, Theunissen EJJM, Cremers CWRJ Hereditary cochleovestibular dysfunction due to a *COCH* gene mutation (DFNA9) a follow-up study of a family. Clin Otolaryngol 2001;26:477-483.
- 69 Verstreken M, Declau F, Wuyts FL, D'Haese P, Van Camp G, Fransen E, Van den Hauwe L, Buyle S, Smets REM, Feenstra L, Van der Stappen A, Van de Heyning PH. Hereditary otovestibular dysfunction and Ménière's disease in a large Belgian family is caused by a missense mutation in the *COCH* gene. Otol Neurotol 2001;22:874-881.
- 70 Lemaire FX, Feenstra L, Huygen PLM, Fransen E, Devriendt K, Van Camp G, Vantrappen G, Cremers CWRJ. Progressive late-onset sensorineural hearing loss and vestibular impairment with vertigo (DFNA9/*COCH*). Longitudinal analyses in a Belgian family Otol Neurotol 2003;24:743-748.
- 71 O'Neill ME, Marietta J, Nishimura D, Wayne S, Van Camp G, Van Laer L, Negrini C, Wilcox ER, Chen A, Fukushima K, Ni L, Sheffield VC, Smith RJH. A gene for autosomal dominant late-onset progressive non-syndromic hearing loss, DFNA10, maps to chromosome 6 Hum Mol Genet 1996;5:853-856.

- 
- 72 Verhoeven K, Fagerheim T, Prasad S, Wayne S, De Clau F, Balemans W, Verstreken M, Schatteman I, Solem B, Van de Heyning P, Tranebjærg L, Smith RJH, Van Camp G Refined localization and two additional linked families for the DFNA10 locus for nonsyndromic hearing impairment *Hum Genet* 2000,107 7-11
- 73 Wayne S, Robertson NG, DeClau F, Chen N, Verhoeven K, Prasad S, Tranebjærg L, Morton CC, Ryan AF, Van Camp G, Smith RJH Mutations in the transcriptional activator *EYA4* cause late-onset deafness at the DFNA10 locus *Hum Mol Genet* 2001,10 195-200
- 74 De Leenheer EMR, Huygen PLM, Wayne S, Smith RJH, Cremers CWRJ The DFNA10 phenotype *Ann Otol Rhinol Laryngol* 2001,110 861-866
- 75 De Leenheer EMR, Huygen PLM, Wayne S, Verstreken M, Declau F, Van Camp G, Van de Heyning PH, Smith RJH, Cremers CWRJ DFNA10/*EYA4* - The clinical picture In Cremers CWRJ, Smith RJH (eds) Genetic hearing impairment Its clinical presentations *Advances in Oto-Rhino-Laryngology*, vol 61 Basel Karger 2002,61 73-78
- 76 Verstreken M, Declau F, Schatteman I, Van Velzen D, Verhoeven K, Van Camp G, Willems PJ, Kuhweide EW, Verhaert E, D'Haese P, Wuyts FL, Van de Heyning PH Audiometric analysis of a Belgian family linked to the DFNA10 locus *Am J Otol* 2000,21 675-681
- 77 Vahava O, Morell R, Lynch ED, Weiss S, Kagan ME, Ahituv N, Morrow JE, Lee MK, Skvorak AB, Morton CC, Blumenfeld A, Frydman M, Friedman TB, King M-C, Avraham KB Mutation in transcription factor *POU4F3* associated with inherited progressive hearing loss in humans *Science* 1998,279 1950-1954
- 78 Frydman M, Vreugde S, Nageris BI, Weiss S, Vahava O, Avraham KB Clinical characterization of genetic hearing loss caused by a mutation in the *POU4F3* transcription factor *Arch Otolaryngol Head Neck Surg* 2000,126 633-637
- 79 Kasai N, Fukushima K, Ueki Y, Prasad S, Nosakowski J, Sugata K, Sugata A, Nishizaki K, Meyer NC, Smith RJH Genomic structures of *SCN2A* and *SCN3A* - candidate genes for deafness at the *DFNA16* locus *Gene* 2001,264 113-122
- 80 Fukushima K, Kasai N, Ueki Y, Nishizaki K, Sugata K, Hirakawa S, Masuda A, Gunduz M, Ninomiya Y, Masuda Y, Sato M, McGuirt WT, Coucke P, Van Camp G, Smith RJH A gene for fluctuating, progressive autosomal dominant nonsyndromic hearing loss, DFNA16, maps to chromosome 2q23-24.3 *Am J Hum Genet* 1999,65 141-150
- 81 Lalwani AK, Goldstein JA, Kelley MJ, Luxford W, Castelein CM, Mhatre AN Human nonsyndromic hereditary deafness DFNA17 is due to a mutation in nonmuscle myosin *MYH9* *Am J Hum Genet* 2000,67 1121-1128
- 82 Lalwani AK, Lanthcum FH, Wilcox ER, Moore JK, Walters FC, San Agustín TB, Mislinski J, Miller MR, Sinniger Y, Attala A, Luxford WM A five-generation family with late-onset progressive hereditary hearing impairment due to cochleosaccular degeneration *Audiol Neurootol* 1997,2 139-154
- 83 Morell RJ, Friderici KH, Wei S, Elfenbein JL, Friedman TB, Fisher RA A new locus for late-onset, progressive, hereditary hearing loss DFNA20 maps to 17q25 *Genomics* 2000,63 1-6
- 84 Elfenbein JL, Fisher RA, Wei S, Morell RJ, Stewart C, Friedman TB, Friderici K Audiologic aspects of the search for DFNA20 a gene causing late-onset, progressive, sensorineural hearing loss *Ear Hear* 2001,22 279-288
- 85 Teig E Hereditary progressive perceptive deafness in a family of 72 patients *Acta Otolaryngol* 1968,65 365-372





# CHAPTER 2

## METHODS



# 2.1

---

## CHARACTERISING AND DISTINGUISHING PROGRESSIVE PHENOTYPES IN NONSYNDROMIC AUTOSOMAL DOMINANT HEARING IMPAIRMENT

P.L.M. Huygen  
R.J.E. Pennings  
C.W.R.J. Cremers

*Audiological Medicine* 2003; 1: 37-46



---

## INTRODUCTION

This report introduces the use of a newly derived method developed especially for convenient and comprehensive phenotype presentation of, and comparison across, progressive HI disorders. It includes construction, starting from regression analysis (threshold on age) of age-related threshold data, of “Age Related Typical Audiograms” (ARTA). ARTA are featuring in a combination plot with an audiogram-like format that covers the relevant age range and constitutes a “fingerprint” characterizing these progressive phenotypes. The method also includes transformation of age-related threshold data (from a regression plot or ARTA) into a one-dimensional so-called “threshold features array”, that can be used for statistical testing on age-related threshold features across HI traits. Given such an array, it is possible to make a reasonable reconstruction of the corresponding ARTA and regression lines for the trait. This indicates that the information content of the threshold features array, despite its one-dimensionality, is high enough to justify its use as a tool for testing on phenotype features across traits. To outline the use of ARTA and the threshold features array, we focused on autosomal dominant non-syndromic progressive HI traits linked to (DFNA) loci for which sufficient data were available or could be obtained. This includes DFNA2, DFNA5, DFNA6/14, DFNA9, DFNA10, DFNA15, DFNA21 and DFNA26.

## MATERIAL AND METHODS

### *Age Related Typical Audiograms (ARTA)*

Many of the patients and families covered by the present paper have been previously described, or their description is currently in press. ARTA were derived from regression analysis (air conduction threshold on age), as previously described (DFNA2, DFNA9, DFNA10, DFNA14 and DFNA21), or performed by ourselves on reported data (DFNA2, DFNA6/14, DFNA15 and DFNA26). Some raw threshold data became available by personal communication, as specified below.

Sources of the used threshold data were as follows: **DFNA2**: Marres et al.<sup>1</sup> (family A); De Leenheer et al.<sup>2</sup> (family B); Kunst et al.<sup>3</sup> (family C); Ensink et al.<sup>4</sup> (family D); personal communications of raw data, in 2000, by Dr Shelley Smith (family E, underlying the report by Coucke et al.<sup>5</sup>) and Drs Margriet Verstreken and Floris

Wuyts (Belgian family, also underlying the report by Coucke et al.<sup>5</sup>) and, in 2001, by Dr Zoreh Talebizadeh (family F, underlying the report by Talebizadeh et al.<sup>6</sup>). **DFNA5**: original reports by Huizing et al.<sup>7-9</sup> and van den Wijngaart et al.<sup>10,11</sup> on a family later linked to this locus (Van Camp et al.<sup>12</sup>); raw data obtained from Dr. Egbert Huizing (personal communication, 2000) and re-analysed by De Leenheer et al.<sup>13</sup> **DFNA6/14**: (see Hereditary Hearing Loss Homepage<sup>14</sup>), Vanderbilt University Hereditary Deafness Study Group,<sup>15</sup> (DFNA6), Kunst et al.<sup>16</sup> (DFNA14). **DFNA9**: raw data underlying the report by Bom et al.<sup>17</sup> **DFNA10**: De Leenheer et al.<sup>18,19</sup> (family A), Verstreken et al.<sup>20</sup> (family B). **DFNA15**: Frydman et al.<sup>21</sup> **DFNA21**: Kunst et al.<sup>22</sup> **DFNA26**: Teig<sup>23</sup> (family recently linked to the same locus as DFNA20 by Fagerheim et al.<sup>24</sup>).

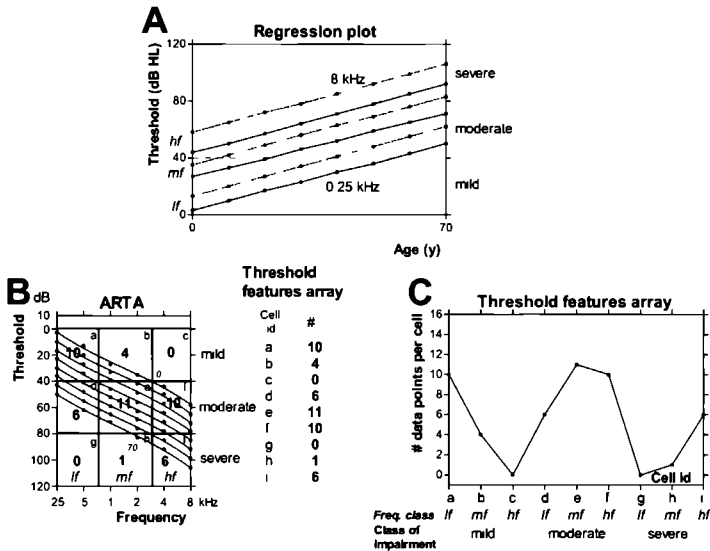

Figure 1 (A-C) Figure illustrating the method used to transform age-related threshold findings obtained in regression plot (A) into ARTA (B) and from there into a threshold features array (C) Data of family D in Fig 3 The number of data points in (A) is counted for 3 frequency classes, 1 e the low frequencies (*lf*, 0.25-0.5 kHz), the mid frequencies (*mf*, 1-2 kHz) and the high frequencies (*hf*, 4-8 kHz) for each class of hearing impairment, mild, moderate and severe The counts of data points per cell (bold) are included in the corresponding cells (identification, a-i) as indicated in top right corner of each cell) in the ARTA panel (B) The one-dimensional threshold features array is included in (B) and the count (#) per cell is plotted in (C) Italic figures 0 and 70 in (B) indicate age

Part of the ARTA included, have already been presented in a different format in previous original or review papers. The present format is a “smoothed” one, the curves having been obtained by applying non-linear regression analysis (Prism 3.02 software, GraphPad, San Diego, CA, US) to approximate the original ARTA.

Second-order or third-order polynomials were used for that purpose, or an equation describing a dose-response curve with variable slope, of which details have been described previously by Bom et al.<sup>25</sup>

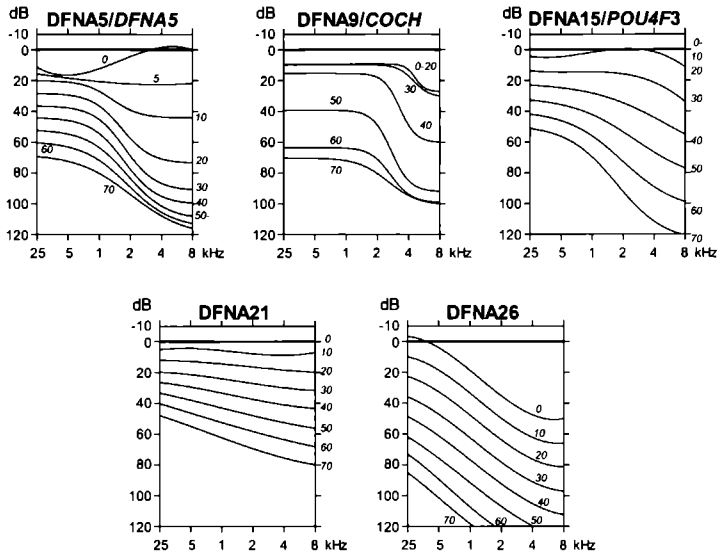

Figure 2. ARTA for the single-family loci DFNA5, DFNA9, DFNA15, DFNA21 and DFNA26. Italics indicate age (year).

### Threshold Features Array (TFA)

An indirect method for statistical testing between threshold-by-age data across loci relating to the threshold predicted for each frequency by regression analysis at fixed ages (0, 10, 20, 30, 40, 50, 60 and 70 years, Figure 1A), or the equivalent ARTA data derived from the latter (Figure 1B) was developed. A 3x3 table was constructed for each complete data set thus obtained that indicates the number of (predicted) data points within the separate 9 cells of this table (Figure 1B). Data classification involved the following frequency classes: low frequency (*lf*, 0.25-5 kHz), mid frequency (*mf*, 1-2 kHz) and high frequency (*hf*, 4-8 kHz). Three HI classes were distinguished: mild (< 40 dB HL), moderate (40-80 dB HL) and severe (> 80 dB HL). The 9 cells of this 3x3 table were designated a-i in such a way that cell a (top left in panel B of Figure 1) contained the number of data points pertaining to mild HI at 0.25-0.5 kHz (*lf*) and cell i contained the number of data



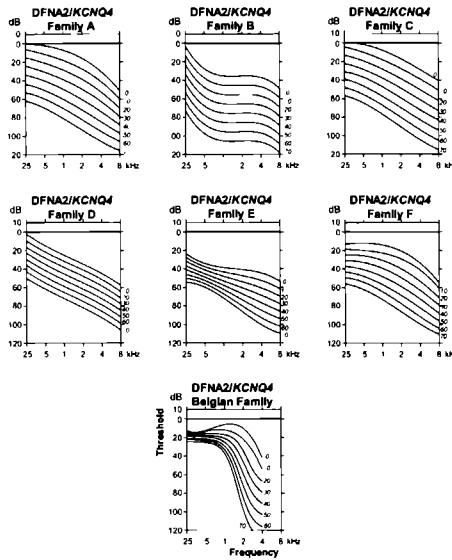

Figure 3 ARTA for a relevant selection of DFNA2 families covering several different (or similar, in families A and B) mutations in the *KCNQ4* gene. Mutations in families A-F affect the potassium channel pore region, the Belgian family has an inactivating mutation

points pertaining to severe HI at 4-8 kHz (*hf*). The contents of all these cells thus established a one-dimensional ( $n=9$ ) array (Figure 1B), which we called the “threshold features array”. This was used for plotting (Figure 1C) and testing purposes in order to compare between phenotypes. Testing between threshold features arrays for the different loci was performed by applying conventional chi-square tests.

## RESULTS

Figure 2 shows the single-family DFNA loci, Figures 3 and 4 relate to multi-family loci. It can be concluded from Figure 3 that chi-square tests applied on threshold features arrays of the DFNA2/*KCNQ4* traits caused by mutations affecting the *KCNQ4* channel pore region (families A-F) did not reveal any significant difference. However, if such tests included the Belgian family harboring a *KCNQ4* inactivating mutation (Figure 3, bottom panel), the corresponding test results indicated significant differences.

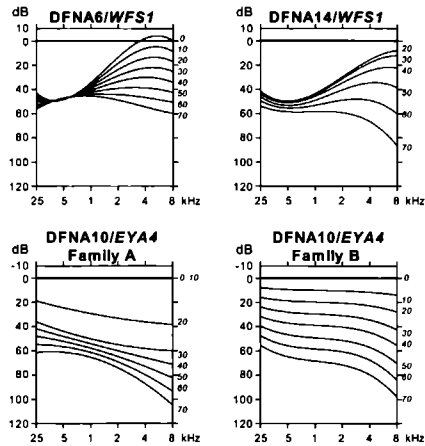

Figure 4. ARTA for some DFNA6/14 and DFNA10 families. Italics indicate age (year)

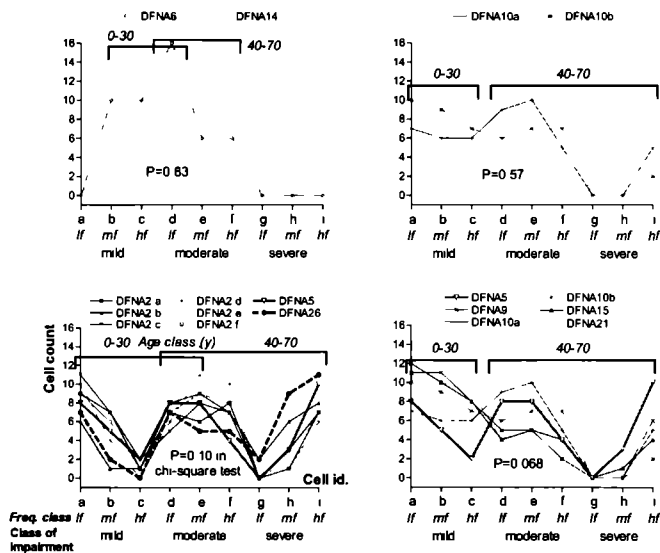

Figure 5. Plots of threshold features arrays for cell count in cells a-i. Plots were superposed for DFNA6 and DFNA14 (top left panel), the two DFNA10 traits (families A and B in Fig. 4 designated here as a and b in top right panel), as well as combinations of loci in apparent phenotype clusters (bottom panels). For DFNA2, the affixed a-f relate to families A-F. Horizontal bars above the plotted counts indicate the age class (0-30 year or 40-70 year, italics) to which the counts plotted below each bar pertain. The P value in each panel shows the result of the chi-square test across all traits included in the plot.

Figure 5 shows plots derived from a number of relevant threshold features arrays. The shape of these plots indicates that the threshold features array to some extent reflects the ARTA. For example, the plot for DFNA6/14 (Figure 5, top left panel) shows culmination of the cell count in cell d, i.e. the cell that pertains to moderate HI in the low-frequency range (Figure 1B). This is in line with the observation that can be made in Figure 4 (top panels) that all audiogram lines of the ARTA in DFNA6/14 start out from a moderate threshold level in the *lf* range. For the cluster of DFNA2, DFNA5 and DFNA26 (Figure 5, bottom left panel), 3 peaks are found in the threshold feature array: in cells a (mild, *lf*), e (moderate, *mf*) and i (severe, *hf*), i.e. corresponding to the predominantly diagonal pattern seen in the ARTA (Figure 3). As indicated in this panel (Figure 5, bottom left), the thresholds predicted for ages 0-30 are mainly represented by cells a-e and those for ages 40-70 by cells d-i. These latter observations were made by preparing separate threshold features arrays and plots (data not shown) for the separate age classes 0-30 year and 40-70 year.

The information content of the threshold features array is substantial: following a few basic rules for calculation (details not shown), it can be demonstrated that it is possible to reconstruct ARTA, or threshold against age plots, from a given threshold features array with a precision of within about 10-20 dB (data not shown). The observation that major phenotype characteristics of a given trait locus are thus reflected in its compact one-dimensional threshold features array suggests that the latter is a suitable tool for testing on major HI features across DFNA traits within a chi-square test setting.

Table 1 Apparent similarity of pure tone threshold features according to chi-square test between threshold features arrays (Yes,  $P > 0.05$ , Yes?,  $P < 0.05$  but close to 0.05)

Locus	DFNA2 <sup>a</sup>	DFNA5	DFNA6/14	DFNA9	DFNA10	DFNA15	DFNA21
DFNA5	Yes						
DFNA6/14							
DFNA9		Yes					
DFNA10		Yes		Yes			
DFNA15		Yes?		Yes			
DFNA21				Yes			Yes
DFNA26	Yes	Yes					

<sup>a</sup>, Belgian trait with inactivating mutation excluded

Table 1 shows the crude results of chi-square tests in pairwise comparisons involving threshold features arrays in terms of fair similarity. There was no significant difference detected between DFNA6 and DFNA14 or between the two

---

DFNA10 traits. Other combination plots and the corresponding P values in Figure 5 illustrate that two different phenotype clusters could be distinguished: one comprising 6 DFNA2 families (A-F), the DFNA5 family and the DFNA26 family (Figure 5, bottom left panel), the other comprising the same DFNA5 family as well as the families with DFNA9, DFNA10, DFNA15 and DFNA21 traits (Figure 5, bottom right panel). As DFNA5 (bold line) forms part of both these clusters, its phenotype features probably are intermediate between those of the two phenotypes covered by these clusters and are not too different from both of them.

## DISCUSSION

Soon after their introduction, ARTA have turned out to be extremely useful in the characterisation of progressive DFNA types. ARTA prepared for several different traits (Figures 2-4) show that it is fairly easy to get a first impression of which traits have fairly similar or dissimilar features. It may, indeed, be much more difficult to compare the original regression lines in the threshold-against-age plots across different traits. The main problems that can be met with the latter type of plots are that progression is non-linear, regression lines or curves cross one another, and the results of formal statistical tests pertaining to the original age-related threshold data depend very much on the numbers of observations and the degree of variability involved. Typically, the lines or curves depicted in ARTA never cross, a feature that accounts for their fingerprint-like appearance. The numbers of observations involved when comparing across ARTA for different traits are (preferably) always the same, so that each trait has the same weight in any comparison test.

For any further use of ARTA, the problem is how to formalise comparisons between ARTA in pairwise or simultaneous comparisons. To this purpose, we designed the threshold features array to transform the data point entries of either the ARTA or the original regression plots into a one-dimensional array. The array entries can be used for plotting purposes; superposition of such plots (Figure 5) obviously avoids superposition of different sets of curves constituting the ARTA, which can be very confusing if a number of traits are involved (Figure 6).

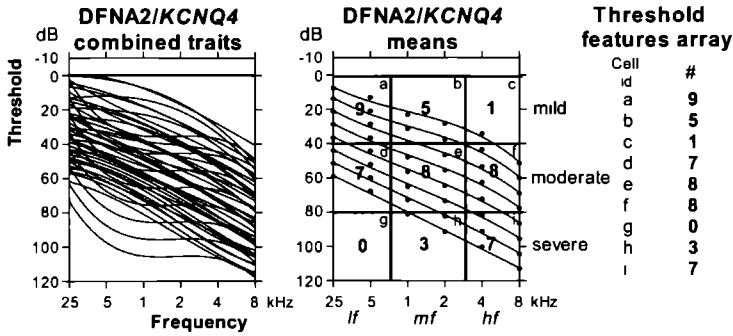

Figure 6 Superposed ARTA for the DFNA2/ KCNQ4 families A-F of Figure 3 are shown in the left panel. Averaging of original threshold data resulted in the data points shown in the right ARTA panel, together with the newly fitted curves. Similar to Figure 1B, the corresponding counts (bold figures) in cells a-i are shown and entered in the threshold features array on the right, that is typical of DFNA2/ KCNQ4 traits with an affected potassium channel pore region and can be used for future testing on hearing impairment features of newly identified traits.

Perhaps even more important is that such arrays are easy to use in pairwise or simultaneous testing across the corresponding traits, employing standard chi-square methods (programs and tables). “Averaged” ARTA and threshold features arrays can be derived which represent normative, typical values to be expected for a specific trait (Table 2). An example is shown in Figure 6. The left panel shows the superposition of the ARTA plots for all the present DFNA2 traits (families A-F in Figure 3) with mutations affecting the KCNQ4 channel pore region. Averaging of data entries as per age and frequency produced the data points depicted in the right ARTA panel of Figure 6. The curves were fitted to these points with third-degree polynomials. Similar to Figure 1, the corresponding threshold features array is shown on the right. This array can be used as being normative for the phenotype of DFNA2/ KCNQ4 mutations affecting the potassium channel pore region. If an apparently similar phenotype is encountered in a new family, the threshold features array for the latter can be derived similarly and the two arrays can be entered in a chi-square test for goodness of fit. The expected values (counts per cell) for the DFNA2/ KCNQ4 phenotype are those shown in Figure 6 and Table 2 and the observed values are those pertaining to the trait to be tested. If the chi-square value (goodness of fit) does not detect a significant difference ( $P < 0.05$ ) between the known phenotype and the new trait, it seems worth the effort to

undertake linkage analysis and or mutation analysis for this trait, guided by this finding.

Using this method, our most recently identified DFNA2/*KCNQ4* family (family B of Figure 3), in fact, was predicted to be a *KCNQ4* family before genetic analysis took place.<sup>2</sup>

Table 2 Threshold features arrays (cell count for cells a-i) for the traits under study that can be used in conventional chi-square tests. Averages pertain to norm values. It should be noted that a conventional chi-square test can be used for testing across separate arrays, but that a chi-square test for goodness of fit should be used if (average) norm values are applied as representing expected values. Prior to performing a conventional chi-square test on a given contingency table, that can be constructed by combining any arrays, cells should be combined where necessary according to general rules described for chi-square tests in most textbooks on statistics.

Trait (Family)	Cell a	Cell b	Cell c	Cell d	Cell e	Cell f	Cell g	Cell h	Cell i
DFNA2 (A)	9	7	1	7	6	8	0	3	7
DFNA2 (B)	6	1	1	8	9	7	2	6	8
DFNA2 (C)	11	7	2	5	8	7	0	1	7
DFNA2 (D)	10	4	0	6	11	10	0	1	6
DFNA2 (E)	7	0	0	9	14	9	0	2	7
DFNA2(F)	9	6	1	7	9	8	0	1	7
<b>Average DFNA2</b>	<b>9</b>	<b>5</b>	<b>1</b>	<b>7</b>	<b>8</b>	<b>8</b>	<b>0</b>	<b>3</b>	<b>7</b>
DFNA2, Belgian family	16	11	0	0	3	6	0	2	10
DFNA5	8	5	2	8	8	4	0	3	10
DFNA6	0	10	10	16	6	6	0	0	0
DFNA14	0	6	12	16	10	3	0	0	1
<b>Average DFNA6/14</b>	<b>0</b>	<b>6</b>	<b>11</b>	<b>16</b>	<b>10</b>	<b>5</b>	<b>0</b>	<b>0</b>	<b>0</b>
DFNA9	11	11	8	5	5	2	0	0	6
DFNA10 (A)	7	6	6	9	10	5	0	0	5
DFNA10 (B)	10	9	7	6	7	7	0	0	2
<b>Average DFNA10</b>	<b>9</b>	<b>6</b>	<b>6</b>	<b>7</b>	<b>10</b>	<b>7</b>	<b>0</b>	<b>0</b>	<b>3</b>
DFNA15	12	10	8	4	5	4	0	1	4
DFNA21	12	10	9	4	6	6	0	0	1
DFNA26	7	2	0	7	5	5	2	9	11

It is obvious that the quality of any normative threshold features array increases with the number of genotyped traits it is based on, provided these traits correspond to fairly similar phenotypes. In the present material, fairly homogeneous phenotypes were found across the entries for families A-F with DFNA2/*KCNQ4* (mutations affecting the channel pore region), the entries for locus DFNA6/14, and those for DFNA10.

A potentially serious problem is the existence of similarity in phenotype of different genotypes, such as is suggested to be the case by the presence in Figure 5

of a phenotype cluster of DFNA2, DFNA5 and DFNA26, as well as a phenotype cluster comprising DFNA5, DFNA9, DFNA10, DFNA15 and DFNA 21. It seems possible that mutations in different genes lead to very similar phenotypes. If a lack of specificity in phenotype is evident from evaluation by ARTA and the threshold features array, additional distinguishing phenotype features can be very important. For example, although the DFNA2 and DFNA5 traits included in our analyses showed fairly similar features, it is clear that these traits have different onset age and progression characteristics. DFNA2 patients are likely to have considerable congenital offset threshold levels, especially at the higher frequencies,<sup>2</sup> in contrast to DFNA5 patients, who do not have any clear HI symptoms or elevated thresholds before the postlingual age of onset.<sup>13</sup> In addition, DFNA5 patients typically show non-linearity of progression, which is most rapid in the initial stages and then gradually slows down, whereas DFNA2 patients show steady, linear progression. Onset age is also different between DFNA5 (5-15 year) and DFNA9 (about 40 year). It may also be important to know whether or not a given trait exhibits progression beyond presbycusis. Other distinguishing phenotype features include speech recognition scores and vestibular dysfunction (for example in DFNA9). Finally, when attempting to distinguish between phenotypes, one should be aware of the relevant genetic epidemiological evidence available. That is, it can be very helpful in a given classification task to realize that many, if not most of the documented trait loci, are amazingly rare, each having been identified only in a single family. Notable exceptions are the multi-family loci DFNA2 and DFNA9, whereas the number of families linked to other loci, for example DFNA6/14(/38), is still increasing.<sup>14</sup>

Features relating to progression in HI can be assessed in more detail than has usually been the case up to now.<sup>26</sup> An easy and convenient way to accomplish this is to establish ARTA and threshold features arrays that can be compared and tested across the different traits in a formal and semi-automatic way. Typical threshold features arrays can be established in the case of multiple occurrences of a given genotype (Figure 6). Such data can then be used in a normative way (i.e. defining expected values) to test (for example, in chi-square tests) whether or not a given phenotype is likely to be similar to already firmly established phenotypes. Based on his phenotypic findings, the clinician can direct the geneticist to search for mutations in a specific gene or perform linkage on a specific genotype. While performing such a task, it should always be kept in mind that different genotypes may have strikingly similar phenotypes.

The ARTA and threshold features arrays, representing the various types of DFNA, so far confirm the correlation between specific genotype and phenotype. Therefore, detailed phenotypic analyses have important consequences, especially when performing research in families affected by hereditary HI. The created ARTA and threshold features array of the investigated families can be used to compare the type of HI, the age of onset, the possible progression of HI and the influence of presbycusis in relationship to other genotypes.<sup>27</sup> However, it does not only help selecting potentially interesting loci for linkage analysis or genes for mutation analysis, but it is also valuable for genetic and individual counseling. ARTA in general depict the progression and deterioration of HI and thus can be very useful for counseling purposes within the investigated family. It may also inspire to undertake fundamental experimental studies on inner ear function in relation to mechanisms underlying genetic HI.

## REFERENCES

- 1 Marres H, van Ewijk M, Huygen P, Kunst H, Van Camp G, Coucke P, Willems P, Cremers C. Inherited nonsyndromic hearing loss. An audiovestibular study in a large family with autosomal dominant progressive hearing loss related to DFNA2. *Arch Otolaryngol Head Neck Surg* 1997;123:573-577
- 2 De Leenheer EMR, Huygen PLM, Coucke PJ, Admiraal RJC, Van Camp G, Cremers CWRJ. Longitudinal and cross-sectional phenotype analysis in a new, large Dutch DFNA2/KCNQ4 family. *Ann Otol Rhinol Laryngol* 2002;111:267-274
- 3 Kunst H, Marres H, Huygen P, Ensink R, Van Camp G, Van Hauwe P, Coucke P, Willems P, Cremers C. Non-syndromic autosomal dominant progressive sensorineural hearing loss: audiological analysis of a pedigree linked to DFNA2. *Laryngoscope* 1998;108:74-80.
- 4 Ensink RJH, Huygen PLM, Van Hauwe P, Coucke P, Cremers CWRJ, Van Camp G. A Dutch family with progressive sensorineural hearing impairment linked to the DFNA2 region. *Eur Arch Otorhinolaryngol* 2000;257:62-67.
- 5 Coucke P, Van Camp G, Djojodiharjo B, Smith SD, Frants RR, Padberg GW, Darby JK, Huizing EH, Cremers CWRJ, Kimberling WJ, Oostra BA, Van de Heyning PH, Willems PJ. Linkage of autosomal dominant hearing loss to the short arm of chromosome 1 in two families. *New Engl J Med* 1994;331:425-431.
- 6 Talebizadeh Z, Kelley PM, Askew JW, Beisel KW, Smith SD. Novel mutation in the KCNQ4 gene in a large kindred with dominant progressive hearing loss. *Hum Mutat* 1999; 14:493-501
- 7 Huizing EH, Van Bolhuis AH, Odenthal DW. Studies on progressive hereditary perceptive deafness in a family of 335 members. I. Genetical and general audiological results. *Acta Otolaryngol* 1965;61:35-41
- 8 Huizing EH, Van Bolhuis AH, Odenthal DW. Studies on progressive hereditary perceptive deafness in a family of 335 members. II. Characteristic patterns of hearing deterioration. *Acta Otolaryngol* 1965;61:161-167.
- 9 Huizing EH, van den Wijngaart WSIM, Verschuure J. A follow-up study in a family with dominant progressive inner ear deafness. *Acta Otolaryngol* 1983;95:620-626.
- 10 van den Wijngaart WSIM, Verschuure J, Brocaar MP, Huizing EH. Follow-up study in a family with dominant progressive hereditary sensorineural hearing impairment. I. Analysis of hearing deterioration. *Audiology* 1985;24:233-240
- 11 van den Wijngaart WSIM, Huizing EH, Niermeijer MF, Verschuure J, Brocaar MP, Blom W. Follow-up study in a family with dominant progressive hereditary sensorineural hearing impairment. II. Clinical aspects. *Audiology* 1985;24:336-342



- 12 Van Camp G, Coucke P, Balemans W, Van Velzen D, Van de Bilt C, Van Laer L, Smith RJH, Fukushima K, Padberg GW, Frants RR, Van de Heyning P, Smith SD, Huizing EH, Willems PJ Localization of a gene for non-syndromic hearing loss (DFNA5) to chromosome 7p15 *Hum Mol Genet* 1995;4 2159-2163.
- 13 De Leenheer EMR, van Zuijlen DA, Van Laer L, Van Camp G, Huygen PLM, Huizing EH, Cremers CWRJ Clinical features of DFNA5 In Cremers CWRJ, Smith RJH (eds) Genetic hearing impairment Its clinical presentations. *Advances in Oto-Rhino-Laryngology*, vol 61 Basel: Karger 2002;61:53-59
- 14 Van Camp G, Smith RJH. Hereditary Hearing Loss Homepage (HHH) Van Camp G and Smith RJH Available at: <http://www.uia.ac.be/dnalab/hhh> Accessed January 19, 2002
- 15 Vanderbilt University Hereditary Deafness Study Group. Dominantly inherited low-frequency hearing loss *Arch Otolaryngol* 1968;88:242-250
- 16 Kunst H, Marres H, Huygen P, Van Camp G, Joosten F, Cremers C. Autosomal dominant non-syndromal low-frequency sensorineural hearing impairment linked to chromosome 4p16 (DFNA14) statistical analysis of hearing threshold in relation to age and evaluation of vestibulo-ocular functions. *Audiology* 1999;38 165-173
- 17 Bom SJH, Kemperman MH, De Kok YJM, Huygen PLM, Verhagen WIM, Cremers FPM, Cremers CWRJ Progressive cochleovestibular impairment caused by a point mutation in the COCH gene at DFNA9 *Laryngoscope* 1999;109 1525-1530
- 18 De Leenheer EMR, Huygen PLM, Wayne S, Smith RJH, Cremers CWRJ The DFNA10 phenotype. *Ann Otol Rhinol Laryngol* 2001;110:861-866.
- 19 De Leenheer EMR, Huygen PLM, Wayne S, Verstreken M, Declau F, Van Camp G, Van de Heyning PH, Smith RJH, Cremers CWRJ. DFNA10/EYA4 - The clinical picture In Cremers CWRJ, Smith RJH (eds) Genetic hearing impairment Its clinical presentations *Advances in Oto-Rhino-Laryngology*, vol 61. Basel Karger 2002;61 73-78
- 20 Verstreken M, Declau F, Schatteman I, Van Velzen D, Verhoeven K, Van Camp G, Willems PJ, Kuhweide EW, Verhaert E, D'Haese P, Wuyts FL, Van de Heyning PH Audiometric analysis of a Belgian family linked to the DFNA10 locus *Am J Otol* 2000;21:675-681
- 21 Frydman M, Vreugde S, Nageris BI, Weiss S, Vahava O, Avraham KB. Clinical characterization of genetic hearing loss caused by a mutation in the POU4F3 transcription factor. *Arch Otol Head Neck Surg* 2000;126:633-637.
- 22 Kunst H, Marres H, Huygen P, van Duijnhoven G, Krebsova A, van der Velde S, Reis A, Cremers F, Cremers C. Non-syndromic autosomal dominant progressive non-specific mid-frequency sensorineural hearing impairment with childhood to late adolescence onset (DFNA21). *Clin Otolaryngol* 2000;25:45-54
- 23 Teig E Hereditary progressive perceptive deafness in a family of 72 patients. *Acta Otolaryngol* 1968;65 365-372
- 24 Fagerheim T, Teslovich TM, Teig E, Barmada MM, Jones M, Gillanders EM, Trent JM, Stephan DA, Tranebjærg L. Mapping of a new family to the DFNA20/26 locus on chromosome 17q25 *The Molecular Biology of Hearing and Deafness*, October 2001 Bethesda, USA [abstract]
- 25 Bom SJH, De Leenheer EMR, Lemaire FX, Kemperman MH, Verhagen WIM, Marres HAM, Kunst HPM, Ensink RJH, Bosman AJ, Van Camp G, Cremers FPM, Huygen PLM, Cremers CWRJ Speech recognition scores related to age and degree of hearing impairment in DFNA2/KCNQ4 and DFNA9/COCH *Arch Otolaryngol Head Neck Surg* 2001;127:1045-1048
- 26 Gorlin RJ, Toriello HV, Cohen MM (eds). *Hereditary hearing loss and its syndromes* Oxford Monographs on Medical Genetics No 28, New York Oxford University Press, 1995
- 27 Pennings RJE, Huygen PLM, Van Camp G, Cremers CWRJ. A review of progressive phenotypes in nonsyndromic autosomal dominant hearing impairment. *Audiol Med* 2003;1 47-55

# CHAPTER 3

## USHER SYNDROME



## VARIABLE CLINICAL FEATURES IN PATIENTS WITH *CDH23* MUTATIONS (USH1d-DFNB12)

R.J.E. Pennings  
V. Topsakal  
L. Astuto  
A.P.M. de Brouwer  
M. Wagenaar  
P.L.M. Huygen  
W.J. Kimberling  
A.F. Deutman  
H. Kremer  
C.W.R.J. Cremers



INTRODUCTION

“Usher syndrome” covers a group of autosomal recessive inherited disorders characterised by sensorineural HI and visual impairment mainly due to RP. In some of the patients vestibular dysfunction also occurs. This syndrome is named after Charles Usher, a Scottish ophthalmologist who described familial retinal pigment disorders and noted that some of his RP patients also had HI.<sup>1</sup> Three different clinical types of Usher syndrome nowadays are known. Usher syndrome type I is characterised by congenital, profound deafness associated with vestibular areflexia

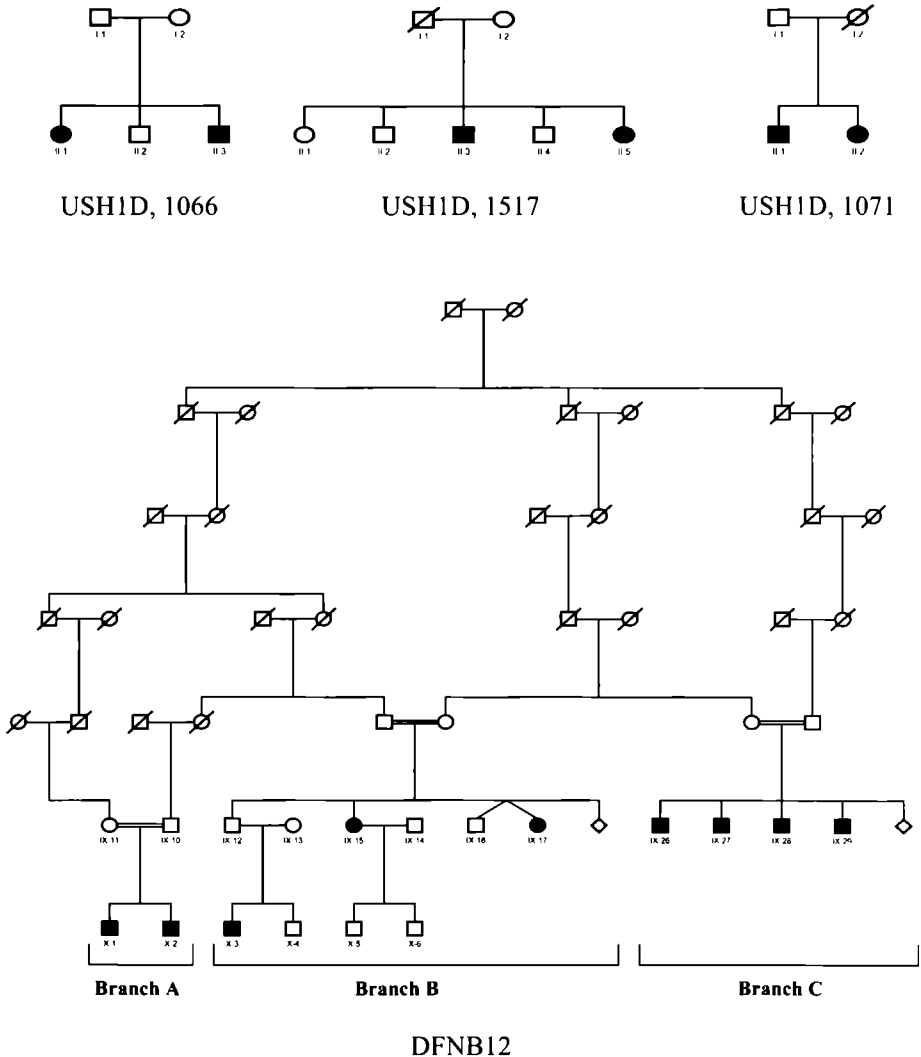

Figure 1. Pedigrees of the 3 USH1d families and 1 DFNB12 family.

and RP. Usher syndrome type II is characterised by moderate to severe sensorineural HI, intact vestibular responses and RP, whereas Usher syndrome type III is characterised by progressive HI, variable vestibular function and RP.<sup>2</sup>

Table 1. Genetic subtypes of Usher syndrome.

	Genotype	Locus	Gene
Usher type I	USH1a	14q32	-
	USH1b	11q13.5	<i>MYO7A</i>
	USH1c	11p15.1	<i>USH1C</i>
	USH1d	10q21-22	<i>CDH23</i>
	USH1e	21q	-
	USH1f	10q21-22	<i>PCDH15</i>
	USH1g	17q24-25	<i>SANS</i>
Usher type II	USH2a	1q41	<i>USH2A</i>
	USH2b	3p23-24.2	-
	USH2c	5q14.3-q21 3	-
Usher type III	USH3	3q21-q25	<i>USH3</i>

Several genotypes were found to be causing these three clinical types of Usher syndrome (Table 1). Currently, 7 loci have been mapped for Usher syndrome type I (USH1A-USH1G), 3 loci for Usher syndrome type II (USH2A-USH2C) and 1 locus for Usher syndrome type III (USH3).<sup>3</sup> Five of the 7 genes involved in Usher syndrome type I have been cloned. Cadherin 23 (*CDH23*) is the gene involved in Usher syndrome type Id (USH1d) and has been mapped to chromosome 10q21-22. This gene is also known to be involved in DFNB12, an autosomal recessive type of nonsyndromic HI. Therefore, USH1d and DFNB12 are allelic disorders.<sup>4-6</sup> The *CDH23* gene is not the only gene involved in syndromic as well as nonsyndromic HI; other genes are: *USH1C* (USH1c/DFNB18), *SLC26A4* (Pendred syndrome/DFNB4), *WFS1* (Wolfram syndrome/DFNA6/14), *COL11A2* (DFNA13/Stickler syndrome) and *MYO7A* (USH1b/DFNA11/DFNB2).<sup>7-12</sup>

This report describes the findings of audiovestibular and ophthalmological examinations in 10 patients from 4 different families (3 USH1d, 1 DFNB12) carrying *CDH23* mutations and relates the encountered features to the underlying genotype.

## PATIENTS AND METHODS

### *Patients, families and the associated genotype*

In this study, 4 families were examined and their pedigrees are shown in Fig. 1. After the identification of pathogenic mutations in the *CDH23* gene (shown in Table 2), these families were contacted again for additional audiovestibular and ophthalmological examinations. From all patients and non-affected family members a written informed consent was obtained. In addition, medical history was taken in all patients focusing on audiovestibular and visual impairment.

Table 2. Genotype of 3 USH1d families and 1 DFNB12 family

	Family	Mutation 1	Mutation 2	Exon	Domain
USH1d	1517	1450G>C (A484P)	1450G>C (A484P)	14	EC5
	1071	IVS45-9G>A	unknown	46	EC19
	1066	IVS20+1G>A	unknown	20	EC7
DFNB12	Branch A	D2148N	D2148N	47	EC20
	Branch B	D2148N	D1341N	47,31	EC20, EC13

EC: extracellular cadherin domain

### USH1D FAMILIES

Two sibs each were affected by Usher syndrome type I in 2 Dutch families (1066 and 1071). In a third family (1517), originating from Flanders, Belgium, again two sibs were affected by Usher syndrome type I. Individual II-5 from this family did not participate in the study, however, her previous clinical data was retrieved with her permission. Mutation analysis of the *CDH23* gene revealed a homozygous 1450G>C mutation in both affected individuals of the Belgian family 1517. This mutation not only leads to an amino acid substitution of proline for alanine at position 484, but also can be predicted to cause a splicing defect of exon 14. In family 1071, one heterozygous mutation in both affected individuals was identified in the *CDH23* gene: IVS45-9 G>A; this mutation affects the splice-acceptor region preceding exon 46. So far, the second mutation has not been identified. In family 1066, a IVS20+1 G>A mutation was identified in *CDH23*, whereas the second mutation in this family remains to be identified. The IVS20+1G>A mutation also disrupts the donor splicing sequence. All identified mutations are located within the extracellular cadherin (EC) domains of cadherin 23 and lead to truncation of the protein. Genetic testing in the USH1D families was performed by heteroduplex analysis and confirmation of the identified mutations by sequencing. Some exons were studied directly by sequencing. This way, in families 1066 and 1071, with only one identified *CDH23* mutation, more than 95% of the known coding region of *CDH23* was screened.



Recently, these genetic findings were described by Astuto et al<sup>13</sup> The BDGP splice-site prediction program available at the Berkely Drosophila Genome Project Splice Site Prediction by Neural Network Web Site<sup>14</sup> was used to predict the effect of splice-site mutations

#### DFNB12 FAMILY

Four patients of the fourth family (W90-004), a large consanguineous family with nonsyndromic autosomal recessive sensorineural HI, were shown to be affected by DFNB12 and 3 of them could be contacted and decided again to participate in this study For individual IX-17, the data retrieved from her previous clinical examinations dating from the seventies and eighties of the past century were used Mutation analysis recently showed that mutations in two different genes were responsible for the HI in this family<sup>15</sup> The HI in branch C of this family (Fig 1) was caused by a homozygous 35delG mutation in the *GJB2* gene (DFNB1) In branch A, patients X-1 and X-2 were found to have a homozygous D2148N mutation in *CDH23*, whereas both patients IX-15 and IX-17 of branch B are compound heterozygous for this mutation and the D1341N mutation These two amino acid substitutions are located in the highly conserved calcium-binding sites of the extracellular cadherin (EC) domains of cadherin 23

#### *Audiometric examinations*

Audiometric examination consisted of standard clinical pure-tone audiometry in a sound-treated room Previously performed audiometric examinations were retrieved to evaluate possible individual progression of HI Some of the previously recorded audiometric data of family W90-004 were described by Marres et al<sup>16</sup> Individual, longitudinal pure tone thresholds were analysed for progression of HI using linear regression analysis (binaural mean air conduction threshold on age) It was checked whether progression could be called significant, i e zero outside 95% confidence interval for slope at 2 or more out of 6 or 7 frequencies At each frequency, the last-visit binaural mean pure tone threshold was compared between USH1d and DFNB12 patients using a 2x2 contingency table and Fisher's exact probability test The level of significance used in all tests was  $p = 0.05$

#### *Vestibular examinations*

Vestibulo-ocular examinations were performed with the patient sitting in upright position in a rotatory chair Visually guided eye movements were evaluated (saccades, optokinetic nystagmus and smooth pursuit eye movements), including

monitoring of the presence of any spontaneous or gaze-evoked nystagmus Vestibular tests were performed in the dark with eyes open The vestibulo-ocular reflex was evaluated using velocity steps of  $90^{\circ}/s$  in either direction with electronystagmography and computer analysis as previously described<sup>17</sup> The cervico-ocular reflex was elicited only in patients showing a lacking vestibulo-ocular reflex<sup>18</sup>

### *Ophthalmological examinations*

Ophthalmological examinations consisted of corrected visual acuity measurements, slit-lamp examinations and funduscopy Visual fields were evaluated by Goldmann perimetry using test targets V-4, III-4 and I-4 Test target III-4 was evaluated according to AMA guidelines<sup>19</sup> Additional ophthalmological tests included electroretinography and electro-oculography, both performed and evaluated according to ISCEV standards<sup>20,21</sup> Colour vision was tested using the Tokyo Medical College colour vision test, the Standard Pseudoisochromatic plates, the Ishihara test, the New Colour test by Lanthony, the Light discrimination test and the Farnsworth-Munsell 100 Hue test, as previously described<sup>22</sup> Dark adaptation was performed with the Goldmann-Weekers adaptometer Finally, the fundus was photographed and fluorescein angiography was performed to record the retinal picture

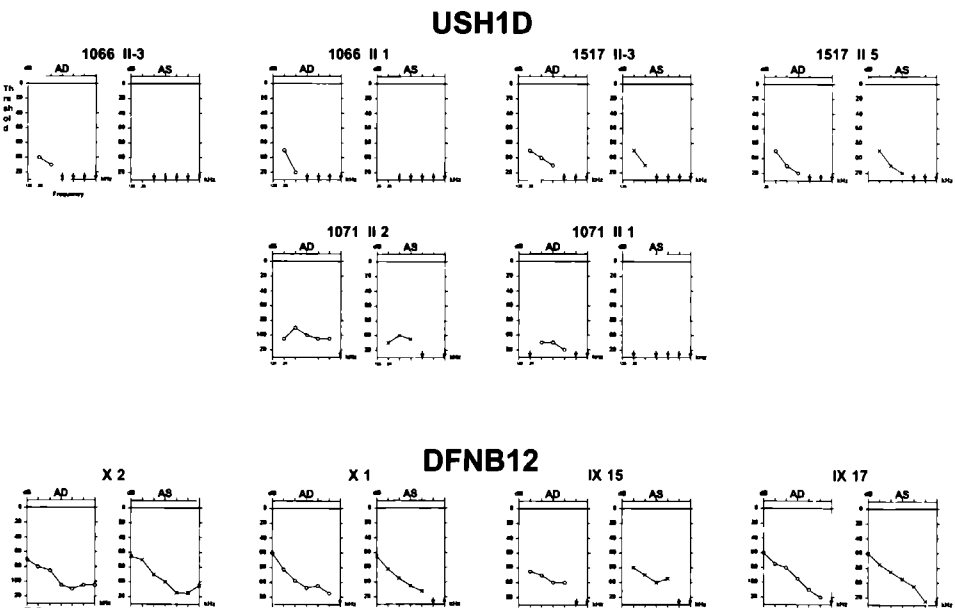

Figure 2 Individual last visit audiograms Circles, right ear (air conduction level), crosses, left ear Downward arrow, out-of scale measurement

## RESULTS

*Audiometric findings*

Longitudinal analysis of pure tone thresholds could be performed in 3 USH1d patients (n = 5-12, range of age: 2-39 years), as well as in 2 DFNB12 patients (n = 4, range of age: 10-40 years). None of these patients showed significant progression of HI (data not shown). Figure 2 shows the individual last-visit audiograms of both patient groups. The USH1d patients generally only had residual hearing at the low frequencies (125 - 500 Hz), whereas the DFNB12 patients showed severe to profound sensorineural HI with thresholds that could be measured up to and including 4 kHz in most cases.

Comparison between USH1d and DFNB12 patients revealed that the USH1d patients had significantly worse hearing than the DFNB12 patients at all frequencies except for the highest ones ( $p < 0.05$ ). Figure 3 shows the "mean audiogram" for the DFNB12 patients (n=4) and the USH1d patients (n=6).

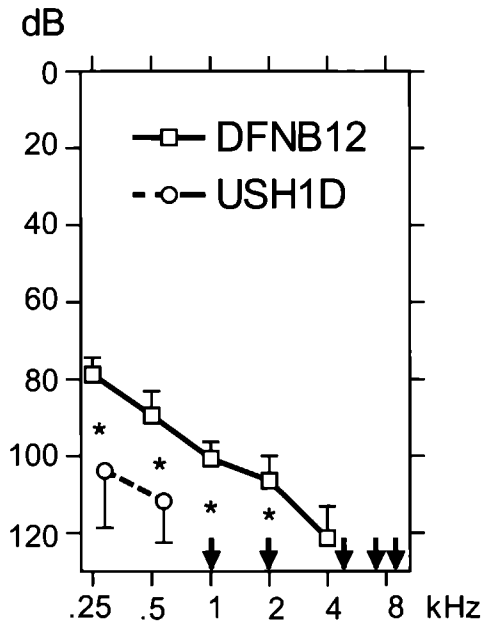

Figure 3 "Mean audiograms" in both patient groups. Bar represents 1SD. Asterisk indicates significant result of Fisher's exact probability test, which included out-of-scale measurements (downward arrow).

---

### *Vestibular findings*

All examined USH1d patients started to walk independently at age > 18 months, except for patient III-1 of family 1066 (at age 12 months). Smooth pursuit was not tested in the USH1d patients because they had difficulty with catching up the target, and was found to be normal in the DFNB12 patients. USH1d patient II:3 of family 1517 (aged 40 years) tended to show spontaneous nystagmus in the dark. Saccades were normal in all patients. Optokinetic nystagmus could be elicited in all USH1d patients, except for the oldest one (II-1, family 1071) who had very poor vision. Optokinetic nystagmus showed sufficiently high slow-phase velocity except in patient II-3 of family 1066 (aged 18 years). Vestibular examinations disclosed vestibular areflexia in all patients and in 3 patients the cervico-ocular reflex was found to be enhanced, which is in line with the findings in labyrinthine-defective subjects previously described by Huygen et al.<sup>18</sup>

### *Ophthalmological findings*

All of the examined Usher syndrome type I patients suffered from nyctalopia in childhood; most of them had been diagnosed to have RP in the first decade of life. As expected, none of the patients with DFNB12 complained about their vision.

Table 3 shows the results of the ophthalmological examinations. None of the 3 DFNB12 patients had evidence of malfunction of the retina. Funduscopy revealed remarkable findings in 2 of the 3 DFNB12 patients. In patient X-1, almost symmetrical small yellowish flecks with central clustering of pigment at the level of the retinal pigment epithelium (RPE) were seen in the posterior pole of both eyes. These flecks were most clearly seen in the right fovea (Fig. 4a). Patient X-2 showed decreased filter action of the RPE on fluorescein angiography and had increased reflexes and minifolds of the internal limiting membrane in the macular area. Patient IX-15 had no retinal abnormalities on funduscopy.

Five USH1d patients had ophthalmological findings characteristic for RP with attenuated vessels, bony spicules, thinning of the RPE and a waxy disk appearance. In patient II-2 of family 1071, a white elevated structure above the disc was seen, as well as a common choroidal naevus (Fig. 4b). This whitish lesion was not unlike the retinal changes seen in Bourneville's tuberous sclerosis.<sup>23</sup> Patient II-3 of family 1517 had remarkable asymmetry of eye findings. His right eye only had light perception and showed severe bony spicules, whereas both were less severe in

Table 3. Visual characteristics in 3 DFNB12 patients and 5 USH1d patients.

		DFNB12				USH1d			
Patient, family		[X-2]	[X-1]	[IX-15]	[II-3], 1066	[II-1], 1066	[II-3], 1517	[II-2], 1071	[II-1], 1071
Gender		male	male	female	male	female	male	female	male
Age (y)		29	33	52	26	33	40	47	51
VAS (%)	RE	105	105	100	90	90	lp	60	No lp
	LE	90	105	100	80	95	80	60	No lp
VFS (%)	RE	100	97	91	51	44	0	31	N.A.
	LE	100	98	93	50	36	43	32	N.A.
FAS (%)		102	105	100	88	94	64	60	0
FFS (%)		108	104	93	51	44	43	32	0
FVS (%)		100	100	93	45	41	28	19	0
Media	RE	Normal	Normal	Normal	minor SPC	vitreous body strings	SPC ++, divergent strabism	SPC ++, surgery	minor SPC
	LE	Normal	Normal	Normal	SPC +	Normal	minor SPC, some cells in vitreous body	SPC ++, surgery	SPC ++, surgery
EOG		Normal	Normal	Normal	Extinguished	Extinguished	Extinguished	N.A.	N.A.
ERG		Normal	Normal	Normal	Extinguished	N.A.	Extinguished	Extinguished	Extinguished
Dark Adaptation		Normal	Normal	Normal	N.A.	N.A.	No lp	N.A.	N.A.
Colour Vision		Normal	Normal	Normal	Red-green defect	Normal	Normal	N.A	N.A.

VFS: Visual Field Score; VAS: Visual Acuity Score; FAS: Functional Acuity Score; FFS: Functional Field Score; FVS: Functional Vision Score; EOG: electro-oculogram; ERG: electroretinogram, N.A.: not available; SPC: subcapsular posterior cataract; lp: light perception; RE: right eye; LE: left eye.

4.A

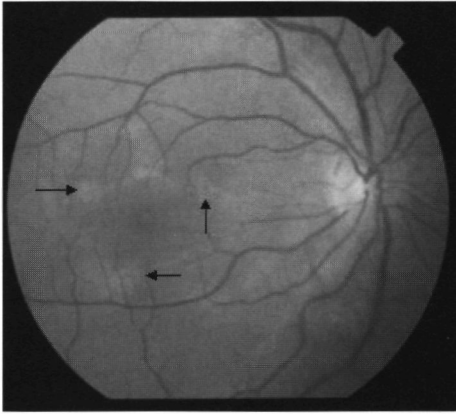

4.B

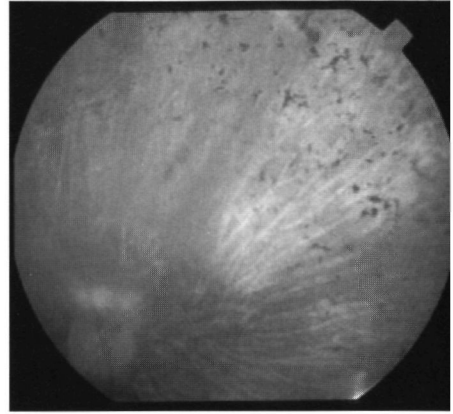

Figure 4. A. Fundus photograph of the right eye of DFNB12 patient X-1, around the macula, depigmentations with central clustering of pigment can be seen (arrows). B. Fundus photograph of the right eye of USH1d patient II-2 of family 1071, a white elevated spot can be seen above the waxy disc, bone spicules and attenuated vessels are also seen. The retinal pigment epithelium has vanished almost completely.

his left eye. In all USH1d patients, the electroretinogram and electro-oculogram were extinguished and poor best-corrected visual acuity scores were found. All patients had tunnel vision confirmed by Goldmann perimetry and all had functional vision scores below 45% (< 50% indicates severe loss of vision).<sup>19</sup> One patient (II:1, family 1071) had total loss of vision. In four of the 5 Usher syndrome patients subcapsular posterior cataracts were seen; two of them have had cataract extraction for this condition, whereas the other patients may need surgery in the future.

## DISCUSSION

Comparison of the audiometric features of 6 USH1d and 4 DFNB12 patients, all identified by at least one mutation in the *CDH23* gene, revealed that the USH1d patients had significantly more HI than the DFNB12 patients. In addition, only the USH1d patients had vestibular areflexia and progressive RP. Two DFNB12 patients showed slightly abnormal funduscopic findings. In patient X-1, bilateral abnormal flecks of the RPE were seen and in patient X-2 slight wrinkling of the

internal limiting membrane and a decreased filter action of the RPE were noticed, although neither of these features caused any functional problems. The present findings are in line with previous observations,<sup>6,13</sup> which noted that amino acid substitutions in *CDH23* cause severe to profound HI with normal vestibular responses and retinal function (DFNB12) and that mutations that lead to *CDH23* protein truncation cause congenital profound deafness, vestibular areflexia and the development of RP (USH1d).

Astuto et al. reported on mutation analysis of *CDH23* in a large group of patients.<sup>13</sup> In a selected panel of probands with Usher syndrome type I, they identified *CDH23* mutations in 35 of 69 probands with Usher syndrome. USH1D was found to be caused by nonsense, frameshift, splice-site and missense mutations. In only 3 families, 2 missense mutations were identified and these families all had an atypical form, with variation in the retinal phenotype, of Usher syndrome type I. All other missense mutations were compound heterozygous with a truncating mutation of the other allele. Nonsyndromic autosomal recessive HI families were also examined and only amino acid substitutions were observed. Results of ophthalmological examinations in these patients with nonsyndromic autosomal recessive deafness in some cases showed asymptomatic RP-like manifestations. Missense mutations in the *CDH23* gene, therefore, may have a subtle effect on the retina, which was also noted in two of the present DFNB12 patients. In addition, Astuto et al. also describe that USH1d patients display a wide range of hearing loss and RP phenotypes, differing in severity, age of onset, type and the presence or absence of vestibular areflexia.<sup>13</sup> The findings in the present USH1d patients are typical for Usher syndrome type I. The second mutation in *CDH23* was not identified in families 1066 and 1071. It may be possible that the second mutation in these families is a splice-site mutation in an intron or is a regulatory mutation which so far can not be detected by heteroduplex analysis.

Cadherin 23 is a transmembrane protein with 27 extracellular cadherin repeats, a transmembrane domain and a cytoplasmic domain. It is encoded by *CDH23*, which consists of 69 exons.<sup>5,6</sup> Cadherins are important for cell-to-cell contact and the organization of the extracellular matrix. Binding of calcium ions to these proteins is essential for linearization, rigidification and dimerization of the cadherin molecules.<sup>24,25</sup> Mutations in *Cdh23* lead to disorganization of the stereocilia of the hair cells in the inner ear of *waltzer*, the mouse model for USH1d.<sup>25</sup> The missense mutations found in the present DFNB12 family and in other DFNB12 families

reported in literature are located in the highly conserved extracellular calcium-binding motifs. Modelling has shown that these mutations are likely to induce a decrease in the capacity for calcium binding.<sup>15</sup> As calcium provides rigidity to the elongated structure of cadherin molecules it is likely that mutations in these calcium-binding motifs lead to a disturbance of the elongated shape of cadherin. Cadherin 23 has been suggested to be a candidate molecule for forming the lateral links or tip links between the stereocilia.<sup>25,26</sup> A disturbed elongated shape of cadherin 23 may therefore lead to disorganisation of the stereocilia because two mutated cadherin 23 molecules are not able to interact directly or with an additional molecule to correctly establish these links.<sup>15</sup> This report shows that the HI caused by mutations in *CDH23* is significantly more severe in USH1d than in DFNB12. It therefore seems likely that the truncated protein in USH1d totally disturbs the interaction and elongated shape of the stereocilia and thus negatively influences the mechano-electrical transduction in cochlear hair cells, whereas the disturbance in function of cochlear hair cells is less severe in the DFNB12 patients with reported amino acid substitutions in the conserved calcium binding motifs. Another pathogenic mechanism is suggested by Wilson et al., who claimed that cadherin 23 may in addition be involved in ion homeostasis of the endolymph in the inner ear, because of expression of *Cdh23* in the utriculo-saccular foramen, the ductus reuniens and Reissner's membrane.<sup>27</sup>

The abnormal funduscopic findings in patient X-1 of the DFNB12 family are atypical for RP, however, they are clearly abnormal. The small flecks may have been caused by previous inflammation of the RPE as described by Krill and Deutman,<sup>28</sup> but this could not be substantiated in this patient. Forgacs and Bozin in 1966 described similar flecks in 2 sisters and therefore suggested a genetic etiology.<sup>29</sup> An alternative explanation of the bilateral flecks and the decreased filter action of the RPE in the present two brothers could be that these two findings relate to accumulation of lipofuscin. Lipofuscin accumulation is known to occur in Stargardt's disease, age-related macular dystrophy and in some forms of RP.<sup>30</sup> The protein of another Usher syndrome type I gene, *MYO7A*, has a crucial function in the normal processing of ingested disk membranes in the RPE, primarily in the basal transport of phagosomes into the cell body where they then fuse with lysosomes.<sup>30</sup> When myosin VIIa is absent, the half-life of the phagosomes is extended and it is suggested that impaired phagosome degradation may be responsible for the accumulation of lipofuscin in the RPE in some forms of RP.<sup>30,31</sup> In the cochlea, several Usher syndrome type I proteins (USH1b, USH1c, USH1d



and USH1g) form a functional complex that shapes the sensory hair cell bundle.<sup>32-34</sup> Hypothetically, these genes may also interact in the process of ingestion of outer segment disk membranes and phagosome degradation in the RPE. Possibly, the lipofuscin accumulation seen in the present two DFNB12 patients is caused by a disturbance of the phagosome degradation in the RPE.

Both DFNB12 patients with abnormal retinal findings, have a homozygous missense mutation (D2148N) in *CDH23*, whereas a normal retina was seen in the older patient IX-15, who was compound heterozygous for two missense mutations (D2148N/D1341N). Possibly, the homozygous combination of the D2148N mutation affects the retina more than a combination of this mutation with D1341N. Another possibility is that this difference is caused by the different position of these two mutations and subsequent relationship with the EC domains. Also, some previously studied USH1d families, characterised as atypical, showed absent, delayed or atypical ophthalmological features suggestive of RP.<sup>35</sup> It may therefore be useful to examine the retina of patients with nonsyndromic autosomal recessive HI for abnormalities, indicating the possible involvement of *CDH23*.

From this study we conclude that the 2 missense mutations in *CDH23*, found in 4 patients of the DFNB12 family, cause nonsyndromic sensorineural HI, which is accompanied by clinically silent funduscopy abnormalities in 2 of the present patients. More elaborate, ophthalmological studies of DFNB12 patients need to be performed to answer the question whether there is a true relationship between the mutations and the encountered funduscopy abnormalities. Inactivating splice-site mutations in *CDH23* were found in 6 patients from 3 USH1d families that lead to significantly more severe HI than in the DFNB12 patients and, in addition, to RP and vestibular areflexia.

## REFERENCES

- 1 Usher CH, On the inheritance of retinitis pigmentosa, with notes of cases. *R Lond Ophthalmol Hosp Rep* 1916;19:130-236
- 2 Davenport SLH and Omenn GS, The heterogeneity of Usher syndrome. Abstract In Littlefield JW, Ebbing FJG and Henderson JW (eds) Fifth International Conference on Birth Defects. Amsterdam, Excerpta Medica 1977:87-88.
- 3 Ahmed ZM, Riazuddin S, Riazuddin S, Wilcox ER. The molecular genetics of Usher syndrome. *Clin Genet* 2003;63:431-444.
- 4 Wayne S, Der Kaloustian VM, Schloss M, Polomeno R, Scott DA, Hejtmančík JF, Sheffield VC, Smith RJH Localization of the Usher syndrome type ID gene (Ush1D) to chromosome 10. *Hum Mol Genet* 1996;5:1689-1692.
- 5 Bolz H, von Brederlow B, Ramírez A, Bryda EC, Kutsche K, Nothwang HG, Seeliger M, del C -Salcedo Cabrera M, Vila MC, Molina OP, Gal A, Kubisch C, Mutation of *CDH23*, encoding a new member of the cadherin gene family, causes Usher syndrome type 1D, *Nat Genet* 2001;27:108-112
- 6 Bork JM, Peters LM, Riazuddin S, Bernstein SL, Zubair MA, Ness SL, Polomeno R, Ramesh A, Schloss M, Srikumari Srisailpathy CR, Wayne S, Bellman S, Desmukh D, Ahmed Z, Khan SH, Der Kaloustian VM, Li XC, Lalwaru A, Riazuddin S, Bitner-Glindzicz M, Nance WE, Liu XZ, Wistow G, Smith RJH, Griffith AJ, Wilcox ER, Friedman TB, Morell RJ Usher syndrome 1D and nonsyndromic autosomal recessive deafness DFNB12 are caused by allelic mutations of the novel cadherin-like gene *CDH23* *Am J Hum Genet* 2001;68:26-37
- 7 Ouyang X, Xia X, Verpy E, Du L, Pandya A, Pett C, Balkany T, Nance WE, Liu X Mutations in the alternatively spliced exons of *USH1C* cause nonsyndromic recessive deafness *Hum Genet* 2002;111:26-30
- 8 Campbell C, Cucci RA, Prasad S, Green GE, Edeal JB, Galer CE, Karniski LP, Sheffield VC, Smith RJH Pendred syndrome, DFNB4, and *PDS/SLC26A4* identification of eight novel mutations and possible genotype-phenotype correlations. *Hum Mutat* 2001;17 403-411
- 9 Bespalova IN, Van camp G, Bom SJH, Brown DJ, Cryns K, DeWan AT, Ewerson AE, Flothmann K, Kunst HPM, Kurnool P, Sivakumaran TA, Cremers CWRJ, Leal SM, Burmeister M, Lesperance MM Mutations in the Wolfram syndrome 1 gene (*WFS1*) are a common cause of low frequency sensorineural hearing loss. *Hum Mol Genet* 2001;15:2501-2508
- 10 McGuirt WT, Prasad SD, Griffith AJ, Kunst HPM, Green GE, Shpargel KB, Runge C, Huybrechts C, Mueller RF, Lynch E, King M-C, Brunner HG, Cremers CWRJ, Takanosu M, Li S-W, Arita M, Mayne R, Prockop DJ, Van Camp G, Smith RJH Mutations in *COL11A2* cause non-syndromic hearing loss (DFNA13) *Nat Genet* 1999;23 413-419
- 11 Weil D, Kussel P, Blanchard S, Levy G, Levi-Acobas F, Drira M, Ayadi H, Pett C. The autosomal recessive isolated deafness, DFNB2, and the Usher 1B syndrome are allelic defects of the myosin-VIIA gene. *Nat Genet* 1997;16:191-193.
- 12 Tamagawa Y, Ishikawa K, Ishikawa K, Ishida T, Kitamura K, Makino S, Tsuru T, Ichimura K Phenotype of DFNA11: a nonsyndromic hearing loss caused by a myosin VIIA mutation *Laryngoscope* 2002;112:292-297
- 13 Astuto LM, Bork JM, Weston MD, Askew JW, Fields RR, Orten DJ, Ohliger SJ, Riazuddin S, Morell RJ, Khan S, Riazuddin S, Kremer H, Van Hauwe P, Moller CG, Cremers CWRJ, Ayuso C, Heckenlively JR, Rohrschneider K, Spandau U, Greenberg J, Ramesar R, Reardon W, Bitoun P, Millan J, Legge R, Friedman TB, Kimberling WJ. *CDH23* mutation and phenotype heterogeneity a profile of 107 diverse families with Usher syndrome and nonsyndromic deafness *Am J Hum Genet* 2002;71:262-275
- 14 Berkely Drosophila Genome Project splice site prediction program. Available at [http://www.fruitfly.org/seq\\_tools/splice.html](http://www.fruitfly.org/seq_tools/splice.html)
- 15 de Brouwer APM, Pennings RJE, Roeters M, Van Hauwe P, Astuto LM, Hoefsloot LH, Huygen PLM, Deutman AF, Bork JM, Kimberling WJ, Cremers FPM, Cremers CWRJ, Kremer H. Mutations in the calcium-binding motifs of *CDH23* and the 35delG mutation in *GJB2* cause hearing loss in one family *Hum Genet* 2003;112:156-163.
- 16 Marres HAM, Cremers CWRJ. Autosomal recessive nonsyndromal profound childhood deafness in a large pedigree. *Arch Otolaryngol Head Neck Surg* 1989;115:591-595.
- 17 Marres HAM, van Ewijk M, Huygen PLM, Kunst HPM, Van Camp G, Coucke P, Cremers CWRJ. Inherited nonsyndromic hearing loss An audiovestibular study in a large family with autosomal dominant progressive hearing loss related to DFNA2. *Arch Otolaryngol Head Neck Surg* 1997;123:573-577.

- 18 Huygen PLM, Verhagen WIM, Nicolassen MGM. Cervico-ocular reflex enhancement in labyrinthine-defective and normal subjects. *Exp Brain Res* 1991;87:457-464
- 19 Cocchiarella L, Andersson GBJ (eds). *Guides to the Evaluation of Permanent Impairment, Chapter 12 The Visual System* 5th edition, pp 277-304 American Medical Association Press, Chicago, 2001.
- 20 Marmor MF, Zrenner E Standard for clinical electroretinography (1999 update) International Society for Clinical Electrophysiology of Vision (ISCEV) *Doc Ophthalmol* 1998;97:143-156.
- 21 Marmor MF, Zrenner E Standard for clinical elector-oculography International Society for Clinical Electrophysiology of Vision (ISCEV). *Doc Ophthalmol* 1993;85:115-124.
- 22 Pinckers A. Clinical color vision examination. *Docum Ophthal Proc Ser* 1984;39:171-179
- 23 Nyboer JH, Robertson DM, Gomez MR Retinal lesions in tuberous sclerosis *Arch Ophthalmol* 1976;94:1277-1280.
- 24 Di Palma F, Pellegrino R, Noben-Trauth K Genomic structure, alternative splice forms and normal and mutant alleles of cadherin 23 (*Cdh23*) *Gene* 2001;281:31-41
- 25 Di Palma F, Holme RH, Bryda EC, Belyantseva IA, Pelligrino R, Kachar B, Steel KP, Noben-Trauth K, Mutations in *Cdh23*, encoding a new type of cadherin, cause stereocilia disorganisation in waltzer, the mouse model for Usher syndrome type 1D *Nat Genet* 2001;27:103-107
- 26 Steel KP, Kros CJ A genetic approach to understanding auditory function. *Nat Genet* 2001;27:143-149.
- 27 Wilson SM, Householder DB, Coppola V, Tessarollo L, Fritzsich B, Lee E-C, Goss D, Carlson GA, Copeland NG, Jenkins NA. Mutations in *Cdh23* cause nonsyndromic hearing loss in *waltzer* mice. *Genomics* 2001;74:228-233.
- 28 Krill AE, Deutman AF Acute retinal pigment epitheliitis. *Am J Ophthalmol* 1972;74:193-205
- 29 Forgacs J, Bozin J. Manifestation familiale de pigmentation groupées de la région maculaire *Ophthalmologica* 1966;152:364-368
- 30 Gibbs D, Kitamoto J, Williams DS Abnormal phagocytosis by retinal pigmented epithelium that lacks myosin VIIa, the Usher syndrome 1B protein *PNAS* 2003;100:6481-6486.
- 31 Kolb H, Gouras P Electron microscopic observations of human retinitis pigmentosa, dominantly inherited *Invest Ophthalmol* 1974;13:487-498.
- 32 Weil D, El-Amraoui A, Masmoudi S, Mustapha M, Kikkawa Y, Laine S, Delmaghani S, Adato A, Nadifi S, Ben Zina Z, Hamel C, Gal A, Ayadi H, Yonekawa H, Pett C, Usher syndrome type 1G (USH1G) is caused by mutations in the gene encoding SANS, a protein that associates with the USH1C protein, harmonin *Hum Mol Gen.* 2003;12:463-471.
- 33 Boëda B, El-Amraoui A, Bahloul A, Goodyear R, Daviet L, Blanchard S, Perfettini I, Fath KR, Shorte S, Reiners J, Houdusse A, Legrain P, Wolfrum U, Richardson G, Petit C Myosin VIIa, harmonin and cadherin 23, three Usher I gene products that cooperate to shape the sensory hair cell bundle. *EMBO* 2002;21:6689-6699.
- 34 Siemens J, Kazmierczak P, Reynolds A, Stcker M, Littlewood-Evans A, Muller U, The Usher syndrome proteins cadherin 23 and harmonin form a complex by means of PDZ-domain interactions, *Proc Natl Acad Sci* 2002;99:14946-14951
- 35 Bork JM, Morell RJ, Khan S, Riazuddin S, Wilcox ER, Friedman TB, Griffith AJ Clinical presentation of DFNB12 and Usher syndrome type 1D. Cremers CWRJ, Smith RJH (eds) in *Genetic Hearing Impairment*. *Adv Otorhinolaryngol* Basel, Karger 2002;61:145-152.

## EVALUATION OF VISUAL IMPAIRMENT IN USHER SYNDROME Ib AND USHER SYNDROME IIa

R.J.E. Pennings  
P.L.M. Huygen  
D.J. Orten  
M. Wagenaar  
A. van Aarem  
H. Kremer  
W.J. Kimberling  
C.W.R.J. Cremers  
A.F. Deutman



---

## INTRODUCTION

The Usher syndromes are a group of autosomal recessive inherited disorders characterised by RP, bilateral sensorineural HI and vestibular dysfunction in some cases. They are the most common cause of deaf-blindness worldwide and the combined prevalence is estimated to range from 3.5 to 6.2 in 100,000 persons.<sup>1,2</sup> The Usher syndromes show clinical as well as genetic heterogeneity. They are divided into 3 clinical types that differ in type and degree of hearing and vestibular impairment. Usher syndromes type I are characterised by profound congenital deafness and vestibular areflexia. Usher syndromes type II show mild to moderate congenital HI with intact vestibular responses, whereas Usher syndrome type III shows remarkable progression of HI and variable vestibular responses. All clinical types I, II and III develop RP later in life, from the first or second decade onwards. Intensive genetic research in the past ten years has led to the identification of 11 loci (USH1A-USH1G, USH2A-USH2C and USH3) and to date 7 genes responsible for Usher syndrome: *MYO7A*(USH1b), *USH1C*(USH1c), *CDH23*(USH1d), *PCDH15*(USH1f), *SANS* (USH1g), *USH2A*(USH2a) and *USH3*(USH3).<sup>3</sup>

RP leads to impaired dark adaptation, progressive visual field constriction and reduction in visual acuity and may eventually lead to blindness. Patients with Usher syndrome are also susceptible to the development of posterior subcapsular cataract that may severely hamper vision but is amenable to surgery.

Several studies on visual field deterioration, visual acuity and fundoscopic appearance on clinically classified<sup>4-9</sup> or genetically linked<sup>10,11</sup> Usher syndrome type I and type II patients have been performed, however, none of these studies categorised patients on the basis of mutation analysis. Most of these studies focused on detecting differences in visual system signs and symptoms between Usher syndrome type I and type II. The present study is similar, however, it is the first one that presents cross-sectional analysis of visual acuity and visual field deterioration related to age to compare between USH1b and USH2a patients, who are all identified by mutation analysis of the *MYO7A* and *USH2A* gene, respectively. In addition, individual serial measurements are presented. To evaluate visual impairment we used the functional acuity score (FAS), functional field score (FFS) and functional vision score (FVS) as defined in the 5<sup>th</sup> edition of the AMA Guides for the Evaluation of Permanent Impairment.<sup>12</sup>

## PATIENTS AND METHODS

### *Patients*

The study included 19 patients from 13 different families with the clinical diagnosis of Usher syndrome type I and 40 patients from 28 different families with the clinical diagnosis of Usher syndrome type II (Tables 1-2). Patients were only included when the visual acuity scores and/or visual fields were evaluated at least once. Patient selection occurred retrospectively as well as prospectively. Some patients only participated in DNA analysis but not in repeat clinical examinations; in these cases previously retrieved examination data were used. Nearly all patients were examined at the Department of Ophthalmology of the University Medical Centre St Radboud, however, a few patients did not come to Nijmegen and with their permission we retrieved visual acuity and Goldmann perimetry examination results from elsewhere. It should be emphasised that the only inclusion criteria used in this study were the clinical diagnosis of Usher syndrome type I or II, the availability of visual function assessments as well as a genetic diagnosis of either USH1b or USH2a. The visual function data were accepted without *a priori* criteria, provided that they were reliably measured and sufficiently documented. The patients enrolled in this study were never subjected to whatever selection on account of their visual acuity or visual field findings.

### *Clinical examinations*

After written informed consent had been obtained, clinical evaluation of most of the affected individuals was performed. This consisted of taking a medical history as well as performing audiovestibular and ophthalmological examinations. The audiovestibular examinations were used to establish the clinical diagnosis of Usher syndrome type I (severe to profound hearing loss and vestibular areflexia) or type II (residual high-frequency HI and intact vestibular responses). Ophthalmological examination consisted of at least one best-corrected visual acuity measurement or one Goldmann perimetry examination. The patients who were examined at the Ophthalmology Department of the UMC St Radboud in addition as a standard underwent external eye examination, slit-lamp microscopy, funduscopy, electro-oculography and electroretinography. The results of these examinations confirmed the diagnosis of RP in all affected individuals and part of

the examination results have been described previously<sup>10,11</sup> The development of posterior subcapsular cataract or lens opacifications may negatively influence visual acuity in Usher syndrome patients Therefore, the FAS was evaluated for USH1b and USH2a patients with cataract or lens opacifications and for those without It was also checked which of them underwent cataract extraction during or outside the observation period

### *Molecular genetics*

Blood samples were collected from the patients for linkage and mutation analysis All type I patients were diagnosed to have USH1b and all type II patients were diagnosed to have USH2a on the basis of a pathogenic mutation of at least one allele within the *MYO7A* and *USH2A* gene, respectively Ten different *MYO7A* mutations were found in our group of USH1b patients, whereas 7 different *USH2A* mutations were identified in the USH2a patients group The distribution and combinations of these mutations within the families are shown in Tables 1 and 2 To determine a possible deleterious effect of truncating mutations when compared to amino acid residue substitutions, the mutations were classified as "inactivating" (+) or "non-inactivating" (-), respectively Given a general lack of sufficient numbers of patients with exactly the same mutation combinations, score behaviour was also compared between different classes of mutation combinations, indicated as +/+, +/-, -/-, +/? and -/?

### *Evaluation of visual acuity and visual field deterioration*

Visual acuity was measured according to common standards by using Snellen charts Best-corrected measurements of both eyes were used for further evaluation The visual acuity measurement for each eye was converted into a visual acuity score (VAS) according to Weber-Fechner's law The functional acuity score (FAS) was determined by the equation  $FAS = (3 \times VAS_{\text{both eyes}} + VAS_{\text{left eye}} + VAS_{\text{right eye}})/5$ <sup>12</sup>

Visual fields were evaluated by Goldmann perimetry of both eyes and in most cases the isopters for the V-4, III-4 and I-4 test targets were measured The Goldmann perimetric fields were quantified by plotting the III-4 isopter according to the description of the American Medical Association in their 5<sup>th</sup> edition of the Guides for the Evaluation of Permanent Impairment<sup>12</sup> The visual field score (VFS) for each eye separately and both eyes combined, was obtained by drawing 10



meridians in the visual field examination form; 2 in each upper quadrant (25°, 65°, 115° and 155°) and three in each lower quadrant (195°, 225°, 255°, 285°, 315°, 345°). These VFSs were converted to a functional field score (FFS) using a similar equation as for the conversion of the VAS. Finally, the functional vision score (FVS) was determined by the FAS and the FFS based on the equation  $FVS = (FFS \times FAS)/100$ .<sup>12</sup>

Table 1 Genotype of 19 USH1b patients examined (families A-M), with one mutation detected, *monoallelic* (? , *second mutation unknown*), or with two mutations detected (**homozygous**, compound heterozygous) and classification of mutation combination in terms of inactivating *versus* non-inactivating mutation. Outlier pertains to cross-sectional analysis (Fig 1)

Patient	Mutations	Type <sup>a</sup>	n	Cataract	Comment
A1	R1240Q/R212C	-/-	2	C+	
A2	R1240Q/R212C	-/-	1	C- <sup>b</sup>	
A3	R1240Q/R212C	-/-	1	C-	
B4	E1170K/?	-/?	2	C-	
C5	<b>R1240Q/R1240Q</b>	-/-	1	C-	
D6	<b>R1743W/R1743W</b>	-/-	1	C-	
D7	<b>R1743W/R1743W</b>	-/-	1	C-	
E8	<b>R212H/R212H</b>	-/-	1	C-	Belgian
E9	<b>R212H/R212H</b>	-/-	1	C-	
F10	E1170K/R1240Q	-/-	1	C-	
G11	<b>E1170K/E1170K</b>	-/-	4	C+	
H12	E1170K/R212H	-/-	1	C-	
H13	E1170K/R212H	-/-	1	C-	
I14	R1240Q/?	-/?	3	C+	
J15	L1840fs/Q1798X	+/+	4	C-	
K16	R1240W/?	-/?	4	C+	
L17	Q1798X/D120fs	+/+	1*	C-	
L18	Q1798X/D120fs	+/+	1	C?	
M19	R666X/?	+/?	2	C-	(outlier low FFS)

<sup>a</sup>, + inactivating, - non-inactivating, ? unknown mutation, <sup>b</sup> Previous cataract extraction at ages 34 and 36 years, \*, limited field evaluation did not enable calculation of functional scores, C+, cataract, C-, no cataract, C?, unknown cataract, n, number of longitudinal measurements

Table 2 Genotype of 40 USH2a patients examined (families A-AB), with one mutation detected, *monoallelic* (? , *second mutation unknown*), or with two mutations detected (**homozygous**, or compound heterozygous mutations) and classification of mutation combination in terms of inactivating *versus* non-inactivating mutation. Outliers pertain to cross-sectional analysis (Fig 1). The longitudinal data of patients commented on are marked in Fig 3 by bold connection lines

Patient	Mutations	Type <sup>a</sup>	n	Cataract	Comment
A1	C419F/?	-/?	2*	C?	
A2	C419F/?	-/?	3	C+	
B3	E767fs/C536R	+/-	7	C+	
C4	E767fs/R317R	+/+	5	C+	
C5	E767fs/R317R	+/+	1	C?	
D6	C419F/?	-/?	3	C+	
D7	C419F/?	-/?	1	C-	
E8	E767fs?	+/?	5	C+	Late onset (age > 40 y) of VA loss and possibly also of field impairment
F9	E767fs?	+/?	4	C+	
G10	C419F/?	-/?	3	C-	
H11	<b>W409X/W409X</b>	+/+	10	C-	Poor VA relative to age and late onset (age > 25 y) of field loss
H12	<b>W409X/W409X</b>	+/+	1	C-	
I13	<b>E767fs/E767fs</b>	+/+	1	C+	
J14	C419F/?	-/?	3	C+	
J15	C419F/C536R	-/-	3	C-	
J16	C419F/?	-/?	1	C+	
J17	E767fs/C536R	+/-	2	C+	
J18	C419F/C536R	-/-	2	C-	
J19	E767fs/?	+/?	2	C-	
K20	<b>C419F/C419F</b>	-/-	1	C+	
L21	E767fs/C419F	+/-	1	C+	
M22	C419F/?	-/?	1	C+	
N23	<b>E767fs/E767fs</b>	+/+	2	C+	
O24	<b>E767fs/E767fs</b>	+/+	1	C+	
O25	<b>E767fs/E767fs</b>	+/+	1	C+	
P26	E767fs/?	+/?	1	C?	
Q27	E767fs/?	+/?	2	C+	
R28	C419F/W409X	-/+	4	C-	These 2 sibs establish a significant cluster characterised by relatively poor FFS and FVS
R29	C419F/W409X	-/+	4	C-	
S30	E767fs/?	+/?	1	C-	
T31	E767fs/?	+/?	1	C-	
U32	<b>E767fs/E767fs</b>	+/+	1	C?	
U33	<b>E767fs/E767fs</b>	+/+	1	C?	
V34	R317R/?	+/?	7	C+	(outlier low FAS)
W35	R317R/?	+/?	4	C-	
X36	C419F/C536R	-/-	2	C-	(outlier high FFS)
Y37	Q748X/Q1468X	+/+	2	C-	
Z38	C536R/?	-/?	4	C-	Late onset (age > 40 y) of VA loss
AA39	C536R/?	-/?	3	C+	
AB40	E767fs/?	+/?	1	C+	

<sup>a</sup>, + inactivating, - non-inactivating, ? unknown mutation, \*, limited field evaluation did not enable calculation of functional scores, C+, cataract, C-, no cataract, C?, unknown cataract, n, number of longitudinal measurements, y, years

In some patients whose previous examination results had been retrieved but could not be updated, the data did not include both visual acuity and visual field measurements obtained on the same day and either of these measurements was lacking in some patients. When similar, consecutive measurements were available, the last-visit measurement was elected for cross-sectional analysis. The present analyses only covered the functional scores FAS, FFS and FVS defined for both eyes.

### *Statistical analysis*

Cross-sectional data were analysed using linear regression analysis. The data included single-snapshot measurements and the last-visit measurements in the cases with longitudinal observations. Significant deterioration was concluded to exist if the 95% confidence interval (CI) for the slope of the regression line did not include zero. Individual linear regression lines pertaining to (part of) the available longitudinal data were derived in some suitable cases to obtain an estimate of (local average maximum) individual longitudinal deterioration rates and compare the results to those obtained in the cross-sectional analysis. Where appropriate, a person's individual regression line was compared to the corresponding cross-sectional regression line that had been recalculated with exclusion of that person's last-visit measurement in order to avoid sharing of the latter data point. A method similar to analysis of covariance (ANCOVA) was used for comparing across regression lines to find out whether or not the lines were significantly different in slope and/or elevation, i.e. the ordinate of the grand mean for a cluster of plotted data points. The program first tested between slopes and then between elevations only if the slopes were not significantly different. Pooling of slopes and Y intercepts across different subgroups of patients (specified in Results) was performed where possible. Separate comparisons between slopes were performed using one-way analysis of variance (ANOVA) and/or Student's t test; this test included Welch's correction if Bartlett's test detected unequal variances. In the cross-sectional analysis, outliers (indicated in Tables 1 and 2 and Fig. 1 below) were identified by using the 95% prediction contours for the regression lines that were calculated initially for all available measurements. A commercial program was used for the statistical analyses and plots (Prism 3, GraphPad, San Diego, CA, USA). The level of significance used in all tests was  $P = 0.05$ .

## RESULTS

### *Methodological considerations*

During the analyses, two potential methodological problems were encountered. First, there was an obvious difference in age distribution between the USH1b and USH2a patients involved in the cross-sectional analysis, which covered only the last-visit and single-snapshot measurements (Fig. 1). Both patient groups showed a pseudonormal distribution for age with mean ages of approximately 27 and 36 years for USH1b and USH2a, respectively. This difference was significant (Student's *t* test). For this reason, we repeated the relevant tests aimed at detecting possible differences in age-dependent cross-sectional scores while matching for age. A window (17-47 years) covering an overlapping range of ages was used that included the youngest USH2a patient (aged 19) and the oldest USH1b patient (aged 45, Fig. 1 below). The second potential problem was the possible influence of cataract development on visual acuity scores. Examinations showed that 4 of the

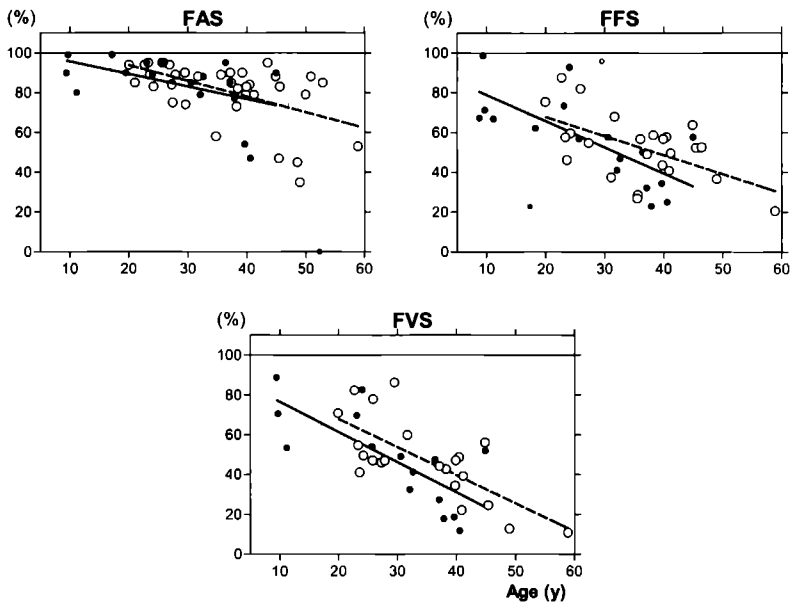

Figure 1. Cross-sectional analysis (last-visit and single-snapshot measurements) in USH1b (filled circles) and USH2a patients (open circles) illustrated in separate plots of the functional scores FAS, FFS and FVS (%) against age (years). The linear regression lines are included in each panel (solid, USH1b; dashed, USH2a). Small symbols, outliers (specified in Tables 1-2) excluded from linear regression analysis. The vertical hairlines mark the window (17-47 years) covering an overlapping age range that was used for matching by age.

18 evaluated USH1b patients and 20 of the 35 evaluated USH2a patients had to some extent developed cataract. However, the difference in prevalence of cataracts between these two patient groups can be explained by the associated age distribution in both patient groups, i.e. the USH2a patients were significantly older. Below, the FAS is compared between patients with and without pre-existent cataracts within each patient group.

*Cross-sectional analysis*

Fig. 1 shows the data points used for the cross-sectional analyses in USH1b and USH2a patients, as well as the regression line calculated for each group. Significant deterioration with advancing age was found in all three types of functional scores in either group of patients. There was no significant difference between the regression lines pertaining to USH1b or USH2a in each of the three types of scores. The pooled values for slope were  $-0.7\%$ ,  $-1.0\%$  and  $-1.5\%$  per year in either patient group for the FAS, FFS and FVS, respectively. Slopes could be pooled across the 3 types of score and the 2 patient groups and was  $-1.0\%$  per year. The results of all the tests comparing score behaviour between the patient groups were essentially similar after matching for age (Fig. 1, vertical hairlines).

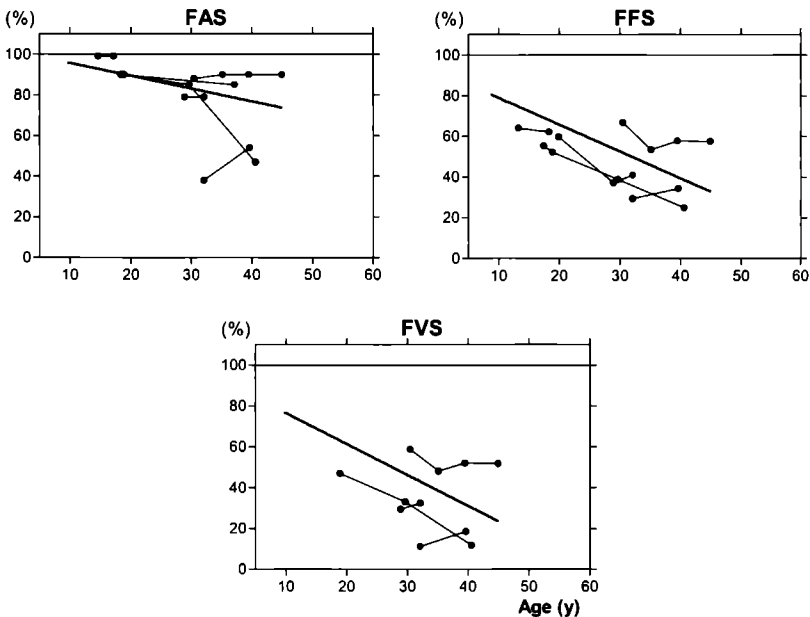

Figure 2. Individual longitudinal analyses (connected symbols) in USH1b patients. The (solid) linear regression line established in the cross-sectional analysis for USH1b was copied from Fig. 1.

### Cross-sectional analysis and cataract

No significant difference in the FAS between (USH1b or USH2a) patients with cataracts and without cataracts appeared when comparing the corresponding regression lines. However, it was noted that USH2a patients with cataracts scored slightly worse than those without (data not shown).

### Longitudinal data

Longitudinal data are shown in Fig. 2 (USH1b) and in Fig. 3 (USH2a). The individual longitudinal regression lines (not included in Figs 2-3 for reasons of clarity) were compared to the corresponding overall cross-sectional regression line (Fig. 2, solid line; Fig. 3, dashed line). This procedure involved only one or two USH1b patients, which did not produce a significant difference between the individual regression line and the corresponding cross-sectional regression line pertaining to all the other USH1b patients.

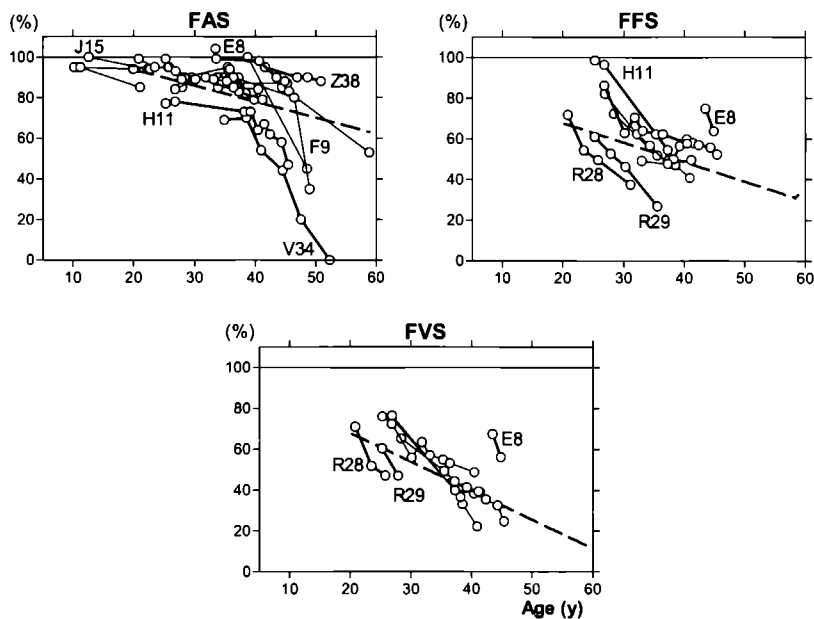

Figure 3 Individual longitudinal analyses (connected symbols) in USH2a patients. The (dashed) regression line established in the cross-sectional analysis for USH2a was copied from Fig. 1. Bold connection lines highlight the patients whose score behaviour deviated substantially/significantly from the trend shown by the cross-sectional regression line (Table 2).

All of the regression lines calculated for the FFS for the separate USH2a patients (data not shown) had a steeper slope (median -2.4%/year) than the cross-sectional regression line (Fig. 3, slope -0.9%/year). The finding of steeper slopes was significant: supposing that the chance of showing a steeper slope than the cross-sectional regression line is  $p = 0.5$ , the probability of finding 7 out of 7 slopes having higher values can be estimated to be 0.008 in the appropriate binomial distribution. Similar observations indicating a discrepancy between the results of the longitudinal and the cross-sectional analyses could be made regarding the plots of the FAS or the FVS against age in USH2a (Fig. 3). Some of the longitudinal data suggested nonlinear development of the functional vision scores with advancing age. In these cases, we estimated an individual "maximum deterioration rate" by visually inspecting the plots and fitting a slope tangent to the part with the steepest descent. The highest estimates based on more than 2 consecutive measurements per patient of the individual maximum deterioration rate for the FAS, i.e. about 5%/year, were found in 2-3 patients (including patient V34) at age 35-50 years (Fig. 3). The last 2 measurements for patient F9 indicated a rate as high as about 20%/year. Maximum individual deterioration rates for the FFS and FVS were about 3-4%/year and 4-5%/year, respectively, in some patients, including R28 and R29 (Fig. 3).

#### *Score behaviour and cataract*

Longitudinal acuity scores (FAS) could be compared relative to age between 5 USH2a patients with and 4 without pre-existent cataracts. Focusing on linear regression analysis of relevant parts of these data, no significant difference between corresponding regression lines was found (data not shown).

#### *Score behaviour and genotype*

Separate cross-sectional analyses and longitudinal analyses (data not shown) were performed covering the separate classes of biallelic mutation combinations +/+, +/-, -/-, -/? and +/?, as shown for the individual patients in Tables 1 and 2. The analyses were repeated with exclusion of the mutation combinations -/? and +/?. There were no significant differences found between regression lines pertaining to any of the different classes of mutation combinations within the USH1b or the USH2a group. As regards separate biallelic mutation combinations, it can be noted that 2 sibs with USH2a (R28 and R29) having the C419F/W409X combination

---

established a significant cluster (Fisher's exact probability test) characterised by relatively poor values of the FFS and FVS (Fig. 3 and Table 2).

## DISCUSSION

### *Development of visual impairment with advancing age in Usher type I and II*

#### PRESENT STUDY

The present cross-sectional analysis (Fig. 1) revealed significant deterioration of the FAS, FFS and FVS with advancing age without any significant difference in score behaviour between the USH1b and USH2a patients, no matter whether or not the window of overlapping ages (17-47 years) was applied. Apart from that, inspection of the available longitudinal data bearing on individual USH2a patients disclosed that some of these patients showed a far higher rate of deterioration than was indicated by the present cross-sectional analysis (Fig. 3). Apparent nonlinear score deterioration made it more appropriate to use (local) "maximal deterioration rates" rather than average rates for some of our USH2a patients. Part of the apparent discrepancy in the results of cross-sectional and longitudinal analyses may have been due to bias of ascertainment: patients experiencing the most severe deterioration are those most likely to undergo repeat examinations. However, even if all the patients who happened to be followed up would have had very similar deterioration rates, it is conceivable that substantial across-subjects differences in the age of onset of deterioration would have attenuated the deterioration rate calculated in the cross-sectional analysis, which, apart from single-snapshot measurements, only included last-visit measurements.

#### PREVIOUS STUDIES

Several previous studies analysed visual acuity and visual field deterioration in Usher syndrome type I and Usher type II patients.<sup>4-9</sup> However, all of these studies only included patients that were classified on the basis of clinical findings and none was based on the results of linkage or mutation analysis. Most of these previous studies showed significantly more favourable visual acuity and visual field measurements in Usher syndrome type II patients than in Usher syndrome type I patients.<sup>4,5,7</sup> Unfortunately, none of these studies comprised appropriate longitudinal analyses. In a study by Seeliger et al.<sup>8</sup> Usher syndrome type II patients seemed slightly less affected than type I patients, however, without any



significant difference. Tsilou et al.<sup>9</sup> also found no significant difference in visual acuity and visual field measurements related to age between type I and type II Usher syndrome patients. Some previous studies have shown a significantly earlier presentation of night blindness in Usher type I and a significantly earlier diagnosis of RP in Usher type I than in Usher type II.<sup>4,9</sup> However, it also seems possible that such findings relate to the fact that USH1b patients, because of their profound deafness combined with vestibular areflexia, depend more on their vision for spatial orientation than do USH2a patients.

#### *Methodological considerations*

Cross-sectional studies based only on clinically classified patients may produce misleading results for at least two important reasons. First, the existence of major genetic heterogeneity, i.e. a mixture of patients with mutations in different genes, cannot be ruled out. Second, cross-sectional data may not reflect the true course of impairment with advancing age, especially if there are substantial across-subjects differences in the age of onset of visual impairment and/or if deterioration proceeds in nonlinear fashion. For both these possibilities we found some indications in the present USH2a patients (Fig. 3). We were unable to uncover substantial, significant differences between our patient groups, i.e. USH1b *versus* USH2a, possibly because of a lack of sufficient suitable data. Provided that sufficient numbers of fully genotyped patients are included, future studies, preferably covering appropriate longitudinal analyses, may demonstrate such differences to exist.

#### *Cataract*

It is known that about 50% of Usher syndrome patients will develop posterior subcapsular cataract in the course of their life.<sup>13</sup> Some of them may undergo cataract extraction to improve visual acuity but, unfortunately, in some others this is no longer effective. No unusual prevalence of intraoperative or postoperative complications has been noted to occur in patients with RP or Usher syndrome.<sup>14</sup> In the present study we found significantly less USH1b patients with cataract than USH2a patients, however, it should be kept in mind that the group of USH2a patients had a significantly higher age at their last-visit measurements than the USH1b patients and that the prevalence of cataracts increases with age. Controlling for age by using regression methods, we could not find any significant difference in FVS behaviour between patients with or without cataract in either

USH1b or USH2a. However, there was an indication of poorer scores in USH2a patients being associated with cataracts. Studies of larger numbers of genotyped patients are probably needed to settle this issue.

#### *Foveal lesions*

A study by Fishman et al.<sup>6</sup> showed that foveal lesions were more prevalent in Usher syndrome type I than in type II. These authors took standard fundus photographs of their patients, which was not done on a regular basis in ours. Perhaps it can be stated that if our Usher syndrome type I patients had similar atrophic- or cystic-appearing foveal lesions as the type I patients described in that study they would have had clearly poorer visual acuity scores than our type II patients, which did not appear to be the case. However, not only the methods of examination differ between the studies, but also the patient selections. A major problem is that we do not know whether or not the Usher type I and II patients described by Fishman et al.<sup>6</sup> show linkage to the same respective loci as ours.

#### *Method to evaluate visual impairment in retinitis pigmentosa*

In literature, several ways of analysing visual field size and visual acuity in patients with RP have been used. In the present study, we followed the 5<sup>th</sup> edition of the Guides to the Evaluation of Permanent Impairment, described by the American Medical Association.<sup>12</sup> To analyse visual field loss, the Esterman grid, or paper and pencil method as described in the Methods section, can be used and both methods lead to similar scores of visual field loss. The advantage of using such methods is that both the decrease in visual field size and visual acuity in a given patient can be integrated into a score of visual impairment, i.e. the FVS (%). The latter score divides the patients into certain classes of impairment, with their related abilities in performing daily living tasks. Patients with a FVS of < 50% may no longer sufficiently benefit from vision enhancement techniques, such as large print, better illumination and better contrast, but may need to shift to vision substitution techniques comprising talking books and Braille.<sup>12</sup> In the present study the USH1b and USH2a patients had FVSs below 50% from about 30 to 40 years of age (Figs 1-3) and should be informed about such possibilities.

*Genotype-phenotype correlation*

Specific combinations of biallelic mutations found in our patients generally did not allow for appropriate statistical testing between the associated score behaviours because of a lack of sufficient numbers of observations. A possible exception was the finding of relatively poor FFS and FVS in 2 sibs with USH2a (R28 and R29, Fig. 3) with the mutation combination C419F/W409X (Table 2). Although, in principle, the functional vision scores of these sibs represent stochastically independent measurements, one cannot exclude the possibility that the similarity in their apparently deviant score behaviour related to the inherent high degree of genotypic similarity. Similar suprafamilial functional vision score findings in patients with the C419F/W409X mutation combination are therefore needed to establish conclusive evidence. Apart from considering specific mutation combinations, the patients were also classified by genotype according to specific types of biallelic combinations in order to increase the number of observations per separate category. Combinations of inactivating and non-inactivating mutations were being considered, because studies in other disorders have shown that inactivating mutations sometimes cause a more severe phenotype in autosomal recessively inherited disorders.<sup>15</sup> We failed to detect any significant difference in functional vision score development with advancing age between the different classes of genotypes causing USH1b or USH2a. Again, this may have been due to the relatively low numbers of patients studied. It seems worthwhile to extend the present study, undertake similar studies at other centres, or perhaps embark on a multi-centre study. This is especially so because molecular genetic knowledge and technology are developing rapidly and complete genotyping of Usher syndrome patients is coming within reach. The patients and their families are also becoming increasingly aware of the new possibilities and opportunities and are developing a growing interest in findings bearing on an individualised prognosis. Detailed clinical studies of phenotype in relation to detailed knowledge of the underlying genotype are necessary to satisfy their and our curiosity.

*Conclusions*

The findings of this study and previous studies seem to be of at least some general value for the counselling and rehabilitation of patients with Usher syndrome and their families. Finetuning of the analyses seems possible in the long run on the basis of the results to be obtained from more elaborate longitudinal studies of phenotype features in fully genotyped patients.

## REFERENCES

- 1 Spandau UHM, Rohrschneider K Prevalence and geographical distribution of Usher syndrome in Germany. *Graefe's Arch Clin Exp Ophthalmol* 2002;240:495-498.
- 2 Rosenberg T, Haim M, Hauch A-M, Parving A The prevalence of Usher syndrome and other retinal dystrophy-hearing impairment associations. *Clin Genet* 1997;51:314-321
- 3 Van Camp G, Smith RJH Hereditary Hearing loss Homepage (HHH) World Wide Web URL <http://dnalab-www.uia.ac.be/dnalab/hhh> Accessed June 1<sup>st</sup>, 2003
- 4 Fishman GA, Kumar A, Joseph ME, Torok N, Anderson RJ. Usher's syndrome Ophthalmic and neuro-otologic findings suggesting genetic heterogeneity *Arch Ophthalmol* 1983;101:1367-1374.
- 5 Piazza L, Fishman GA, Farber M, Derlacki D, Anderson RJ. Visual acuity loss in patients with Usher's syndrome. *Arch Ophthalmol* 1986;104:1336-1339
- 6 Fishman GA, Anderson RJ, Lam BL, Derlacki DJ Prevalence of foveal lesions in type 1 and type 2 Usher's syndrome *Arch Ophthalmol* 1995;113:770-773.
- 7 Edwards A, Fishman GA, Anderson RJ, Grover S, Derlacki DJ Visual acuity and visual field impairment in Usher syndrome. *Arch ophthalmol* 1998;116:165-168
- 8 Seeliger M, Pfister M, Gendo K, Paasch S, Apfelstedt-Sylla E, Plinkert P, Zenner H-P, Zrenner E Comparative study of visual, auditory and olfactory function in Usher syndrome. *Graefe's Arch Clin Exp Ophthalmol* 1999;237:301-307.
- 9 Tsilou ET, Rubin BI, Caruso RC, Reed GF, Pikus A, Hejtmancik JF, Iwata F, Redman JB, Kaiser-Kupfer MI. Usher syndrome clinical types I and II Could ocular symptoms and signs differentiate between the two types? *Acta Ophthalmol Scand* 2002;80:196-201.
- 10 van Aarem A, Wagenaar M, Pinckers AJLG, Huygen PLM, Bleeker-Wagemakers EM, Kimberling WJ, Cremers CWRJ. Ophthalmological findings in Usher syndrome type 2A *Ophthalmic Genet* 1995;16:151-158
- 11 Wagenaar M. The Usher syndrome - a clinical and genetic correlation PhD-thesis, Catholic University Nijmegen, 2000, the Netherlands
- 12 American Medical Association Chapter 12 The visual system. In: Cocchiarella L & Anderson GBJ (eds) *Guides to the Evaluation of Permanent Impairment*, 5<sup>th</sup> edition. Chicago. American Medical Association Press. 2001; 277-304.
- 13 Auffarth GU, Tetz MR, Krastel H, Blankenagel A, Volcker HE. Cataract complicata bei verschiedenen Formen der Retinitis Pigmentosa. *Art und Häufigkeit Ophthalmologe* 1997;94 642-646
- 14 Newsome DA, Stark WJ Jr, Maumenee IH. Cataract extraction and intraocular lens implantation in patients with retinitis pigmentosa or Usher's syndrome. *Arch Ophthalmol* 1986;104 852-854
- 15 Cryns K, Pfister M, Pennings RJE, Bom SJH, Flothmann K, Caethoven G, Kremer H, Schatteman I, Köln KA, Tóth T, Kupka S, Blin N, Nürnberg P, Thiele H, van de Heyning PH, Reardon W, Stephens D, Cremers CWRJ, Smith RJH, Van Camp G Mutations in the WFS1 gene that cause low-frequency sensorineural hearing loss are small non-inactivating mutations *Hum Genet* 2002;110 389-394.



## PURE TONE HEARING THRESHOLDS AND SPEECH RECOGNITION SCORES IN DUTCH PATIENTS CARRYING MUTATIONS IN THE *USH2A* GENE

R.J.E. Pennings  
P.L.M. Huygen  
M.D. Weston  
A. van Aarem  
M. Wagenaar  
W.J. Kimberling  
C.W.R.J. Cremers



## INTRODUCTION

In 1858 Albrecht von Graefe was the first to describe the combination of bilateral sensorineural HI and tapetoretinal degeneration.<sup>1</sup> This combination was later named after Charles Usher, an ophthalmologist who described several families with hereditary retinal pigment disorders and HI in the Bowman lecture of 1935.<sup>2</sup> Julia Bell was the first to emphasise differences in HI between affected individuals.<sup>3</sup> Davenport and Omenn introduced a clinical classification for the Usher syndrome in 1977.<sup>4</sup> After several modifications, three different types of Usher syndrome are characterised on the basis of their audiovestibular phenotype. Usher syndrome type I shows severe to profound congenital HI and vestibular areflexia. Usher syndrome type II shows congenital HI that is mild to moderate with intact vestibular responses. Type III of the Usher syndrome is mainly seen in Finland and has progressive hearing loss without precisely defined vestibular responses. Typically, the essential difference in symptoms between Usher syndrome type I and II can be characterised by stating that type I patients assess themselves as deaf individuals becoming blind, whereas type II individuals regard themselves as blind persons with a hearing problem.<sup>5</sup>

Classification is now mainly based on genetic subtyping. To date, eleven different loci and six different genes, of which three (*CDH23*, *PCDH15* and *USH3*) only recently were described, are known to cause the Usher syndromes (Table I). In 1990 the first locus for Usher syndrome type II was mapped to chromosome 1q<sup>6</sup>, which was followed eight years later by the detection of the gene (*USH2A*) responsible for Usher syndrome type IIa.<sup>7</sup>

The first detailed reports on pure tone threshold, speech recognition score and vestibular analysis data in Usher syndrome type II patients without knowledge of the correlated genotype was given by Myers et al.<sup>8</sup> and Kumar et al.<sup>9</sup> Previous reports by our group described part of the present patients to evaluate progression of HI in longitudinal<sup>10</sup> and cross-sectional<sup>11</sup> analyses. However, this was done without the present genotype identification based on more elaborate mutation analysis.

The present report describes features of HI in Dutch Usher syndrome patients with one or two mutations in the *USH2A* gene. Cross-sectional analysis was performed on raw (uncorrected) and presbycusis-corrected pure tone audiometry data, as well as on speech recognition scores.



Table 1 Genetic subtypes of Usher syndrome and their chromosomal localization, gene and important reference(s)

Usher subtype	Chromosome	Gene	Reference - year
		USHER TYPE I	
Usher Ia	14q32	-	Kaplan et al <sup>29</sup> - 1992
Usher Ib	11q13.5	<i>MYO7A</i>	Weil et al <sup>30</sup> - 1995
Usher Ic	11p15.1	<i>USH1C</i>	Verpy et al <sup>31</sup> , Bitner-Glindzicz et al <sup>32</sup> - 2000
Usher Id	10q21-q22	<i>CDH23</i>	Bork et al <sup>21</sup> , Bolz et al <sup>33</sup> - 2001
Usher Ie	21q	-	Chaib et al <sup>34</sup> - 1997
Usher If	10q21.1	<i>PCDH15</i>	Ahmed et al <sup>35</sup> , Alagramam et al <sup>36</sup> - 2001
Usher Ig	17q24-q25	-	Mustapha et al <sup>37</sup> - 2002
		USHER TYPE II	
Usher IIa	1q41	<i>USH2A</i>	Eudy et al <sup>7</sup> - 1998
Usher IIb	3p23-24.2	-	Hmani et al <sup>38</sup> - 1999
Usher IIc	5q14.3-21.3	-	Pieke-Dahl et al <sup>39</sup> - 2000
		USHER TYPE III	
Usher III	3q21-25	<i>USH3</i>	Joensuu et al <sup>40</sup> - 2001

## PATIENTS AND METHODS

In this study, audiometric data of 36 Usher syndrome patients with one or two mutations in the *USH2A* gene were examined. These patients, 17 men and 19 women, had a mean age of 38 years (range 14-57 year). Eleven Dutch families only had one affected individual. Ten other Dutch families had more than one person affected with Usher syndrome. All were diagnosed to have Usher IIa on the basis of a pathogenic mutation of at least one allele within the *USH2A* gene. Three different mutations (E767FS, C419F and W409X) were found to be responsible for Usher syndrome in these 36 patients. In 21 patients the *USH2A* gene was mutated in only one allele (group A). Of these 21 patients, there are 14 affected sibs from 6 families and 7 isolates. Allele segregation around the *USH2A* locus confirms our presumed *USH2A* diagnosis in aforementioned sibships. In 15 patients, homozygous or compound heterozygous mutations were identified (group B).

After informed consent, clinical examination of affected individuals was performed consisting of medical history taking, audiovestibular and ophthalmological examinations. Vestibular testing was performed as previously described by Marres et al.<sup>12</sup> Ophthalmological examination included external eye examination, corrected visual acuity measurements, Goldmann perimetry, slit-

---

lamp microscopy, ophthalmoscopy, electro-oculography and electroretinography. The results of the ophthalmological examinations confirmed the presence of tapetoretinal degeneration and some were described previously.<sup>13</sup> All patients were clinically diagnosed to have Usher syndrome type II on the basis of their vestibular responses.

The audiometric profile of these patients was evaluated at various ages. Pure tone (air and bone conduction) thresholds for the different sound frequencies (0.25 – 8 kHz) and speech recognition scores were assessed according to ISO norms.<sup>14,15</sup> Bone conduction levels were evaluated only to exclude conductive hearing loss. Statistical analyses were performed on the total group of patients as well as the subgroups A and B.

Last-visit pure tone audiometry threshold data (binaural mean of air conduction) were used for cross-sectional linear regression analysis (threshold on age) using Prism 3.02 software (GraphPad, San Diego, CA, USA). Progression was designated significant when a significant positive slope ( $P < 0.025$ ) was determined. A significantly high prevalence of this finding among the frequencies tested ( $p < 0.05$  in the corresponding binomial distribution) was considered to be conclusive evidence of progression. Individual threshold data were corrected for presbycusis by subtracting the (sex- and age-related) median ( $P_{50}$ ) presbycusis threshold as indicated by the ISO 7029 norm.<sup>16</sup> Progression of threshold data beyond presbycusis was evaluated in a similar way. ARTA were derived on the basis of the results of the cross-sectional regression analysis of the raw (uncorrected) threshold data.

Individual (mean of monaural) maximum phoneme recognition scores (%Correct) from last-visit performance-intensity plots were submitted to cross-sectional regression analysis in 30 patients. A similar analysis was also applied to performance-impairment data (maximum phoneme score plotted against average pure tone thresholds at 1, 2 and 4 kHz ( $PTA_{1-4 \text{ kHz}}$ )), as well as for performance-age data (maximum phoneme score plotted against age). The 90%Correct score ( $X_{90}$ ) was called onset age with age as the X coordinate and onset level with  $PTA_{1-4 \text{ kHz}}$  being the X coordinate. The slope in the performance-age plot was called deterioration rate and the slope in the performance-intensity plot was called deterioration gradient. Nonlinear regression analysis was applied using the

alternative equation for the regression line,  $Y = \text{slope}(X-X_{90}) + 90$ , to obtain the 95% confidence interval (95% CI) for  $X_{90}$ .

To compare slopes and intercepts across the different sound frequencies, as well as between subgroups A and B, analysis of covariance (ANCOVA) was used. Intercepts and slopes were pooled, where this appeared to be permitted.

## RESULTS

All 36 patients generally showed a down-sloping pure tone audiogram. The cross-sectional analysis of the pure tone threshold data of all patients (circles) is illustrated by Figure 1. Significant progression of HI (bold regression lines) was detected. Comparison between slopes (ANCOVA) did not detect a significant difference ( $F=0.65$ ,  $DFn=5$ ,  $DFd=402$ ,  $P=0.66$ ). The pooled slope or Annual Threshold Deterioration (ATD) was 0.5 dB/year. Intercepts were significantly different (ANCOVA,  $F=102.6$ ,  $DFn=5$ ,  $DFd=407$ ,  $P<0.0001$ ). After correction for presbycusis (asterisks), HI only showed significant progression at 0.25-0.5 kHz (dotted and bold dashed lines). The ATD for presbycusis-corrected data could not be pooled across frequencies ( $F=2.82$ ,  $DFn=5$ ,  $DFd=402$ ,  $P=0.016$ ); it decreased gradually from 0.6 dB/year at 0.25 kHz to virtually zero at 4-8 kHz (there was no point in comparing the intercepts for this reason).

Group A (heterozygous *USH2A* mutations) and group B (homozygous or compound heterozygous *USH2A* mutations) showed no significant difference in threshold related to age (separate group data not shown). There was no substantial difference in threshold related to age detected between patients with different mutations or combinations of mutations (separate data not shown).

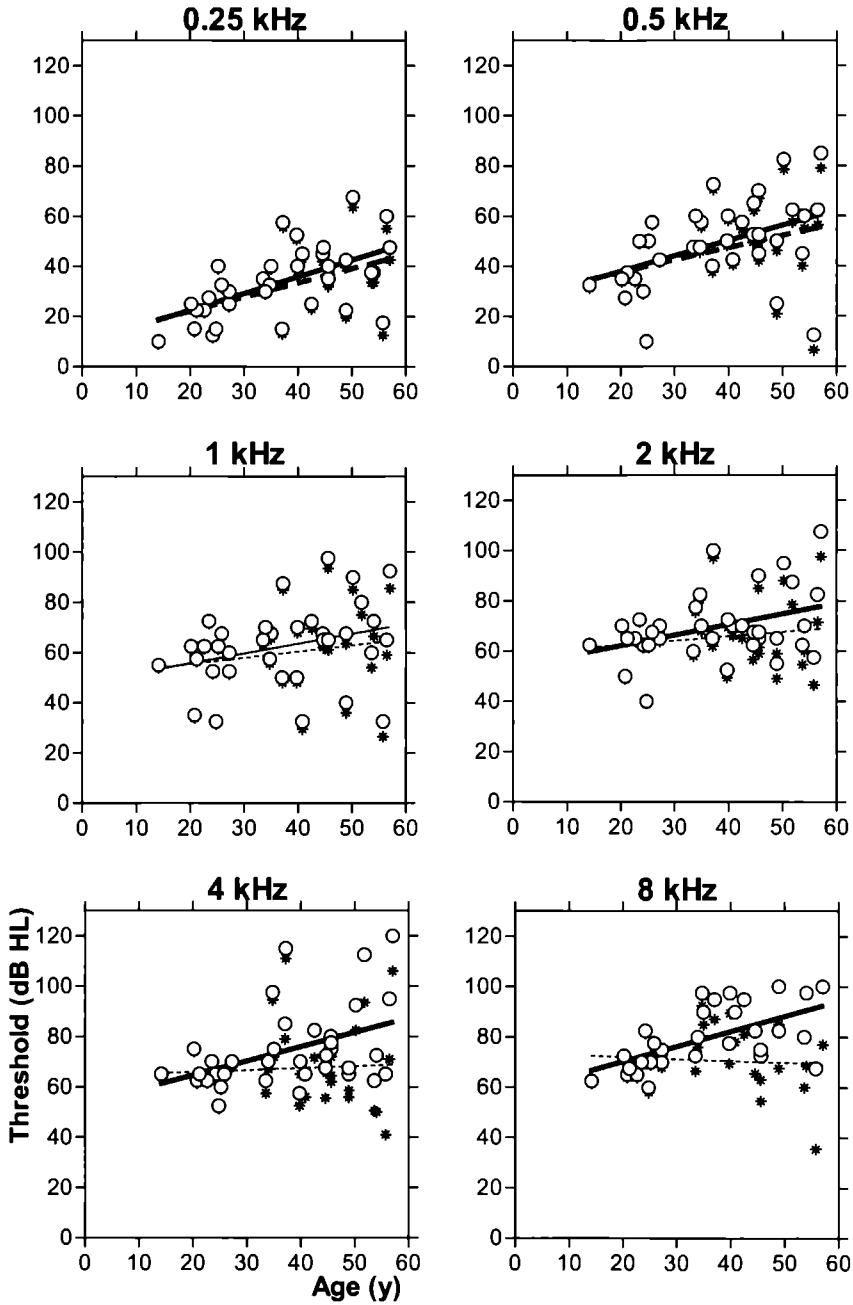

Figure 1 Cross-sectional analysis of binaural mean air conduction threshold (dB HL, circles) in 36 Dutch USH2a patients. Regression lines are included and bold when significant progression was detected. Dotted and dashed lines represent presbycusis-corrected data (asterisks).

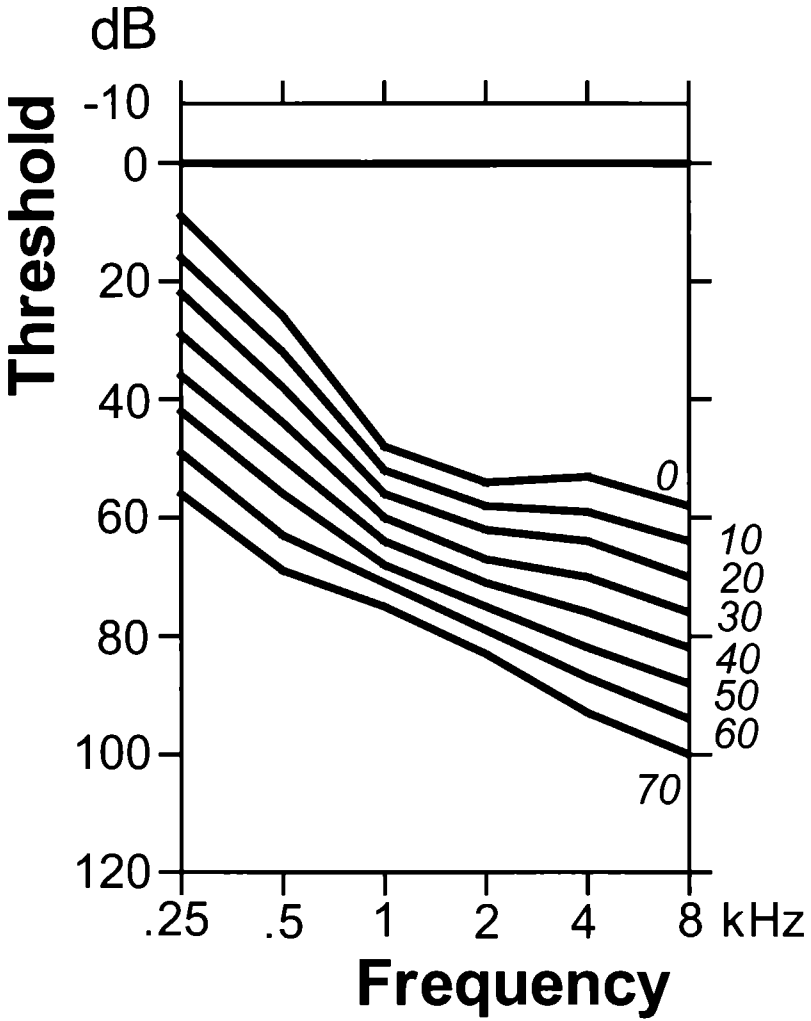

Figure 2 Age Related Typical Audiograms (ARTA) Age is given in italics

ARTA for the patient group as a whole are shown in Figure 2. The pooled audiogram slope was about -9 dB per octave.

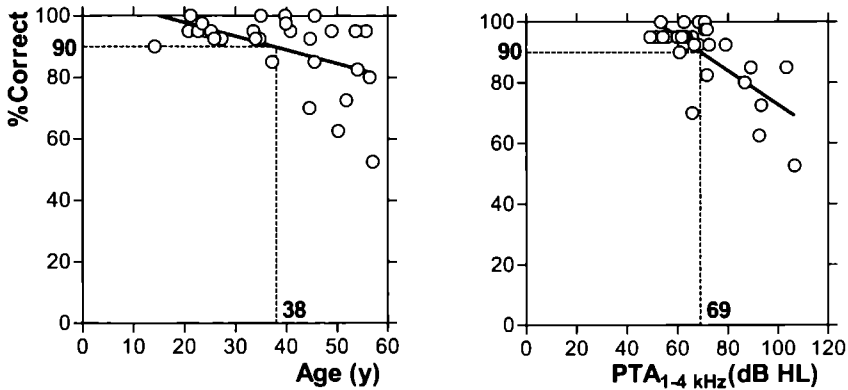

Figure 3 Cross-sectional analysis of mean monaural phoneme recognition score (%Correct at maximum performance) related to age (year) and  $PTA_{1-4\text{ kHz}}$  (dB HL) for 30 Usher IIa patients. Linear regression lines (bold continuous lines) are depicted. Dotted lines and bold figures relate to the 90%Correct score ( $X_{90}$ ).

Figure 3 shows the plots for speech performance in relation to age and the level of HI. The performance-age plot (left panel) shows an onset age of 38 year (95% CI: 29-46 year) and a deterioration rate of 0.4 %/year (95% CI: 0.1-0.7 %/year). The performance-impairment plot (right panel) shows an onset level of 69 dB HL (95% CI: 64-74 dB HL) and a deterioration gradient of 0.6 %/dB HL (95% CI: 0.4-0.8 %/dB HL). There was no significant difference in speech recognition score behavior between the subgroups A and B (data not shown).

## DISCUSSION

All patients, diagnosed with USH2a based on one or two mutations in *USH2A*, showed HI with a downsloping audiogram configuration with a mean threshold slope of  $-9$  dB per octave that was mildly progressive by about 0.5 dB per year. After correction for mean presbycusis, significant progression only persisted at 0.25-0.5 kHz. No tangible difference was found in threshold related to age between group A (single mutation in *USH2A*) and group B (homozygous or compound heterozygous mutations in *USH2A*). Speech recognition scores for these patients were virtually normal up until the fourth decade of life and continued to be relatively good at a more advanced age in the face of the level of impairment developed.

In a longitudinal regression analysis performed on pure tone audiograms of 23 USH2a patients diagnosed on the basis of linkage analysis, van Aarem et al.<sup>10</sup> found cases with stable as well as progressive hearing loss. Wagenaar et al.<sup>11</sup> performed cross-sectional regression analysis of pure tone audiograms of 27 USH2a patients. Eleven of these patients were found to have the relatively frequent 2299delG (formerly designated 2314delG) *USH2A* mutation, the remaining sixteen had been linked to the *USH2A* locus. They found progressive HI of 0.7 dB/year on average for 0.25-4 kHz that could not be explained by presbycusis alone. They also concluded that USH2a could be distinguished from USH1b at age < 40 year by the thresholds at the low frequencies (0.25-1 kHz) (11). The present study focused on families who are known to have a pathogenic mutation in at least one allele of the *USH2A* gene. Up to now, in some of the families included in our previous studies<sup>10,11</sup>, no mutations in *USH2A* were found, despite positive LOD scores. A search for the common 2299delG mutation was first conducted on our Usher syndrome type II patients. The entire *USH2A* gene in patients without this specific mutation was sequenced to detect other possible pathogenic mutations.

The most common mutation in *USH2A* is the 2299delG (E767FS) mutation. Recently, a common origin of this widespread geographic mutation was suggested by Dreyer et al.<sup>17</sup> Usherin (*USH2A*) is known to code for several domains. It contains one laminin type VI domain, ten laminin-like epidermal growth factor (EGF) domains and four fibronectin type III domains.<sup>18</sup> W409X is a nonsense mutation and C419F a missense mutation located in the laminin type VI domain. E767FS is a nonsense mutation found in the laminin-like EGF domain. The exact function and role of usherin in the cochlea and retina is still unknown. In the present study we could not detect any difference in hearing features between patients carrying either of the three detected mutations. This may be due to the limited number of cases in this study. It is also possible that an appropriate longitudinal study uncovers tangible differences in progression between different patients, as apparently was the case in a previous study<sup>10</sup>, that go undetected in a cross-sectional study. Of the three patients who showed significant progression in that study, only one [patient F11 in ref. 10] was included in the present study; a homozygous W409X mutation was found in this patient.

Some of the genes responsible for the Usher syndromes also harbour mutations that cause recessive or dominant forms of sensorineural HI. *MYO7A*, the gene responsible for USH1b, also harbours mutations that cause DFNA11 and DFNB2.<sup>19,20</sup> Mutations in *CDH23* (USH1d) are also responsible for DFNB12.<sup>21</sup> At this moment no recessive or dominant forms of nonsyndromic HI have been ascribed to *USH2A*, however, a missense mutation (Cys759Phe) seems to cause a recessive form of RP without hearing loss, as described by Rivolta et al.<sup>22</sup> These examples show that syndromic and non-syndromic forms of HI and pigmentary retinopathy may be caused by different mutations in one gene.

Detailed pure tone threshold and speech recognition score data have been previously reported by others in Usher type II patients without knowledge of the genotype.<sup>8,9</sup> We performed linear regression analysis of these data using the present methods and found results that were fairly similar to those obtained in our USH2a patients as depicted in Figure 1 (previously published data not included). However, one possible difference with the present results was that the Usher type II threshold data<sup>8,9</sup> did not show any significant progression, except for the 8 kHz frequency. This may have been caused by the generally larger amount of scatter that appeared to be present in their Usher type II threshold data<sup>8,9</sup>, which may or may not have been related to (unknown) heterogeneity in genotype in the previously established Usher type II group.

Table 2 Results of cross-sectional analysis of speech recognition scores related to age or level of hearing impairment for the present group of USH2a patients and previously described groups of patients having DFNA2<sup>23</sup>, DFNA5<sup>24</sup> or DFNA9<sup>23</sup>

	SPEECH RECOGNITION SCORES RELATED TO			
	Age (year)		PTA <sub>1-4kHz</sub> (dB HL)	
	Onset age (year)	Deterioration rate (%/year)	Onset level (dB HL)	Deterioration gradient (%/dB HL)
USH2a/ <i>USH2A</i>	38	0.4	69	0.6
DFNA2/ <i>KCNQ4</i> <sup>23</sup>	34	0.3	65	0.5
DFNA5/ <i>DFNA5</i> <sup>24</sup>	16	0.7	41	0.4
DFNA9/ <i>COCH</i> <sup>23</sup>	43	1.8	45	1.2

Table II shows the present results compared to those obtained in speech recognition studies conducted in additional autosomal dominant non-syndromic types of HI with fairly similar audiometric characteristics: DFNA2<sup>23</sup>, DFNA5<sup>24</sup> and DFNA9<sup>23</sup>. The speech recognition score data published in previous reports on Usher type II patients<sup>8,9</sup> were also re-analysed with the present methods. The



deterioration rate and gradient were fairly similar to those obtained in our Usher IIa patients. However, onset age in the previously reported Usher type II patients<sup>8,9</sup> may have been younger and onset level may have been lower compared to our patients. Given their age and level of pure tone thresholds, our USH2a patients had fairly similar speech recognition scores to those of DFNA2/*KCNQ4* patients, as described by Bom et al.<sup>23</sup> Initially, *KCNQ4* was thought to be expressed predominantly in the outer hair cells of the cochlea.<sup>25</sup> However, recent findings in the rat suggest that expression follows gradients and is strongest in the inner hair cells of the lower turn and the outer hair cells of the upper turn of the cochlea.<sup>26</sup> Because DFNA2/*KCNQ4* is associated with primary dysfunction of the lower turns of the cochlea, this probably is related to a lack of K<sup>+</sup> channels in inner hair cells. Outer hair cells are supposed to operate as “cochlear preamplifiers” that are involved in cochlear fine-tuning mechanisms.<sup>27</sup> Bom et al. therefore suggested the possibility that relative sparing of outer hair cell function relates to relatively good speech recognition in DFNA2/*KCNQ4*.<sup>23</sup> Because DFNA2 resembles USH2a not only in pure tone audiometry but also in speech behavior, a similar effect can be suggested to occur in USH2a. Suggestions to the same extent have been made for DFNA5/*DFNA5*<sup>24</sup>, in sharp contrast with DFNA9/*COCH*, where the relatively poor speech recognition is thought to be caused by widespread pathologic intracochlear alterations.<sup>23,28</sup> Up to now, no specific cochlear locations or functions have been identified for usherin that might support or refute the present hypothesis of primary involvement of outer hair cells, especially in the lower cochlear turns.

From the present study can be concluded that Usher syndrome patients with one or two mutations in the *USH2A* gene have moderate to severe sensorineural HI with a downsloping audiogram-pattern that is mildly progressive at about 0.5 dB HL per year.

## REFERENCES

- 1 Von Graefe A Vereinzelte Beobachtungen und Bemerkungen. Exceptionelles Verhalten des Gesichtsfeldes bei Pigmentenartung der Netzhaut Von Graefe's Arch Ophthal 1858,4:250-253.
- 2 Usher CH The Bowman lecture, on a few hereditary eye affections. Trans Ophthalmol Soc UK 1935;55 164-170.
- 3 Bell J Retinitis pigmentosa and allies diseases. In Pearson K (ed), The treasury of human inheritance, London, Cambridge Press 1922;2-19.

- 4 Davenport SLH, Omenn GS The heterogeneity of Usher syndrome In Littlefield JW, Ebbing FJG, Henderson JW (eds) Fifth International Conference on Birth Defects Amsterdam Excerpta Medica 1977 87-88 (abstract)
- 5 Kimberling WJ, Möller C Clinical and Molecular Genetics of Usher syndrome J Am Acad Audiol 1995, 6 63-72
- 6 Kimberling WJ, Weston MD, Möller C, Davenport SL, Shugart YY, Priluck IA, Martini A, Milani M, Smith RJ Localization of Usher syndrome type II to chromosome 1q Genomics 1990,7 245-249
- 7 Eudy JD, Weston MD, Yao S, Hoover D, Rehm HL, Ma-Edmonds M, Yan D, Ahmad I, Cheng JJ, Ayuso C, Cremers CWRJ, Davenport S, Moller C, Talmadge CB, Beisel KW, Tamayo M, Morton CC, Swaroop A, Kimberling WJ, Sumegi J Mutation of a gene encoding a protein with extracellular matrix motifs in Usher syndrome type IIa Science 1998, 280 1753-1757
- 8 Meyer DH, Piazza L, Fishman GA Evaluation of pure tone and speech discrimination changes in Usher's syndrome Ann Otol Rhinol Laryngol 1989,98 364-368
- 9 Kumar A, Fishman G, Torok N Vestibular and auditory function in Usher's syndrome Ann Otol Rhinol Laryngol 1984,93 600-608
- 10 van Aarem A, Huygen PLM, Pinckers AJLG, Bleeker-Wagemakers EM, Kimberling WJ, Cremers CWRJ Stable and progressive hearing loss in type 2A Usher syndrome Ann Otol Rhinol Laryngol 1996, 105 962-967
- 11 Wagenaar M, van Aarem A, Huygen PLM, Pieke-Dahl S, Kimberling WJ, Cremers CWRJ Hearing impairment related to age in Usher syndrome type 1B and 2A Arch Otolaryngol Head Neck Surg 1999,125 441-445
- 12 Marres HAM, van Ewijk M, Huygen PLM, Kunst HPM, Van Camp G, Coucke P, Cremers CWRJ Inherited nonsyndromic hearing loss An audiovestibular study in a large family with autosomal dominant progressive hearing loss related to DFNA2 Arch Otolaryngol Head Neck Surg 1997,123 573-577
- 13 Van Aarem A, Wagenaar M, Pinckers AJLG, Kimberling WJ, Cremers CWRJ Ophthalmologic findings in Usher syndrome type 2A Ophthalmic Genet 1995,16 151-158
- 14 International Organization for Standardization ISO 389 Acoustics Standard Reference Zero for the Calibration of Pure Tone Air Conduction Audiometers Geneva, Switzerland, International Organization for Standardization, 1985
- 15 International Organization for Standardization ISO 8253-1 Acoustics Audiometric Test Methods, I Basic Pure Tone Air and Bone Conduction Threshold Audiometry Geneva, Switzerland, International Organization for Standardization, 1989
- 16 International Organization for Standardization ISO 7029 Acoustics Threshold of Hearing by Air Conduction as a Function of Age and Sex for Otologically Normal Persons Geneva, Switzerland, International Organization for Standardization, 1984
- 17 Dreyer B, Tranebjærg L, Brox V, Rosenberg T, Moller C, Beneyto M, Weston MD, Kimberling WJ, Cremers CWRJ, Liu X-Z, Nilssen Ø A common ancestral origin of the frequent and widespread 2299delG *USH2A* mutation Am J Hum Genet 2001,69 228-234
- 18 Weston MD, Eudy JD, Fujita S, Yao S-F, Usami S, Cremers CWRJ, Greenburg J, Ramesar R, Martini A, Möller C, Smith RJ, Sumegi J, Kimberling WJ Genomic structure and identification of novel mutations in *usherin*, the gene responsible for Usher syndrome type IIa Am J Hum Genet 2000,66 1199-1210
- 19 Liu X-Z, Walsh J, Tamagawa Y, Kitamura K, Nishizawa M, Steel KP, Brown SDM Autosomal dominant non-syndromic deafness caused by a mutation in the myosin VIIA gene Nat Genet 1997,17 268-269
- 20 Liu X-Z, Walsh J, Mburu P, Kendrick-Jones J, Cope MJTV, Steel KP, Brown SDM Mutations in the myosin VIIA gene cause non-syndromic recessive deafness Nat Genet 1997,16 188-190
- 21 Bork JM, Peters LM, Riazuddin S, Bernstein SL, Ahmed ZM, Ness SL, Polomeno R, Ramesh A, Schloss M, Srisailpathy CRS, Wayne S, Bellman S, Desmukh D, Ahmed Z, Khan SN, Der Kaloustian VM, Li C, Lalwani A, Riazuddin S, Bitner-Glindzicz M, Nance WE, Liu X-Z, Wistow G, Smith RJH, Griffith AJ, Wilcox ER, Friedman TB, Morell RJ Usher syndrome 1D and nonsyndromic autosomal recessive deafness DFNB12 are caused by allelic mutations of the novel cadherin-like gene *CDH23* Am J Hum Genet 2001,68 26-37
- 22 Rivolta C, Sweklo EA, Berson EL, Dryja TP Missense mutation in the *USH2A* gene association with recessive retinitis pigmentosa without hearing impairment Am J Hum Genet 2000,66 1975-1978
- 23 Bom SJH, De Leenheer EMR, Lemaire FX, Kemperman MH, Verhagen WIM, Marres HAM, Kunst HPM, Ensink RJH, Bosman AJ, Van Camp G, Cremers CWRJ Speech recognition scores related to age and degree of hearing impairment in DFNA2/*KCNQ4* and DFNA9/*COCH* Arch Otolaryngol Head Neck Surg 2001, 127(9) 1045-1048

- 24 De Leenheer EMR, van Zuijlen, Van Laer L, Van Camp G, Huygen PLM, Huizing EH, Cremers CWRJ. Further delineation of the DFNA5 phenotype. Results of speech recognition tests. *Ann Otol Rhinol Laryngol* 2002;111:639-641.
- 25 Kubisch C, Schroeder B, Friedrich T, Lutjohann B, Petit C, Jentsch TJ *KCNQ4*, a novel potassium channel expressed in sensory outer hair cells, is mutated in dominant deafness. *Cell* 1999;96:437-446.
- 26 Beisel KW, Nelson NC, Delmont DC, Fritsch B Longitudinal gradients of *KCNQ4* expression in spiral ganglion and cochlear hair cells correlate with progressive hearing loss in DFNA2. *Mol Brain Res* 2000;82 137-149.
- 27 Nobili R, Mammano F, Ashmore J. How well do we understand the cochlea? *Trends Neurosci* 1998;21 159-167
- 28 Robertson NG, Resendes BL, Lin JS, Lee C, Aster JC, Adams JC, Morton CC Inner ear localization of mRNA and protein products of *COCH*, mutated in the sensorineural deafness and vestibular disorder, DFNA9. *Hum Mol Genet* 2001;10:2493-2500
- 29 Kaplan J, Gerber S, Bonneau D, Rozet JM, Delrieu O, Briard ML, Dollfus H, Ghazi I, Dufier JL, Frezal J, Munnich A A gene for Usher syndrome type I (*USH1A*) maps to chromosome 14q. *Genomics* 1992;14:979-987
- 30 Weil D, Blanchard S, Kaplan J, Guilford P, Gibson F, Walsh J, Mburu P, Varela A, Leveilliers J, Weston MD, Kelley PM, Kimberling WJ, Wagenaar M, Levi-Acobas F, Larget-Piet D, Munnich A, Steel KP, Brown SDM, Petit C Defective myosin VIIA gene responsible for Usher syndrome type 1B. *Nature* 1995;374 60-61
- 31 Verpy E, Leibovici M, Zwaenepoel I, Liu X-Z, Gal A, Salem N, Mansour A, Blanchard S, Kobayashi I, Keats BJB, Slim R, Petit C. A defect in harmonin, a PDZ domain-containing protein expressed in the inner ear sensory hair cells, underlies Usher syndrome type 1C. *Nat Genet* 2000;26:51-55
- 32 Bitner-Glindzic M, Lindley KJ, Rutland P, Blaydon D, Smith VV, Milla PJ, Hussain K, Furth-Lavi J, Cosgrove KE, Shepherd RM, Barnes PD, O'Brien RE, Farndon PA, Sowden J, Liu X-Z, Scanlan MJ, Malcolm S, Dunne MJ, Aynsley-Green A, Glaser B. A recessive contiguous gene deletion causing infantile hyperinsulinism, enteropathy and deafness identifies the Usher type 1C gene. *Nat Genet* 2000;26 56-60
- 33 Bolz H, von Brederlow B, Ramirez A, Bryda EC, Kutsche K, Nothwang HG, Seeliger M, del C.-Salcedó Cabrera M, Caballeró Vila M, Pelaez Molina O, Gal A, Kubisch C Mutation of *CDH23*, encoding a new member of the cadherin gene family, causes Usher syndrome type 1D. *Nat Genet* 2001;27:108-112
- 34 Chaib H, Kaplan J, Gerber S, Vincent C, Ayadi H, Slim R, Munnich A, Weissenbach J, Petit C A newly identified locus for Usher syndrome type I, *USH1E*, maps to chromosome 21q21. *Hum Molec Genet* 1997;6:27-31.
- 35 Ahmed ZM, Riazuddin S, Bernstein SL, Ahmed Z, Khan S, Griffith AJ, Morell RJ, Friedman TB, Riazuddin S, Wilcox ER Mutations of the protocadherin gene *PCDH15* cause Usher syndrome type 1F. *Am J Hum Genet* 2001;69:25-34.
- 36 Alagramam KN, Yuan H, Kuehn MH, Murcia CL, Wayne S, Srisailpathy CRS, Lowry RB, Knaus R, Van Laer L, Bernuer FP, Schwartz S, Lee C, Morton CC, Mullins RF, Ramesh A, Van Camp G, Hagemen GS, Woychik RP, Smith RJH. Mutations in the novel protocadherin *PCDH15* cause Usher syndrome type 1F. *Hum Mol Genet* 2001 10:1709-1718.
- 37 Mustapha M, Chouery É, Torchard-Pagnez D, Nouaille S, Khrais A, Sayegh FN, Mégarbané A, Loiselet J, Lathrop M, Petit C, Weil D A novel locus for Usher syndrome type I, *USH1G*, maps to chromosome 17q24-25. *Hum Genet* 2002;110:348-350.
- 38 Hmani M, Ghorbel A, Boulila-Elgaied A, Ben Zina Z, Kammoun W, Drira M, Chaabouni M, Petit C, Ayadi H. A novel locus for Usher syndrome type II, *USH2B*, maps to chromosome 3 at p23-24.2. *Eur J Hum Genet* 1999;7:363-367
- 39 Pieke-Dahl S, Moller CG, Kelley PM, Astuto LM, Cremers CWRJ, Gorin MB, Kimberling WJ Genetic heterogeneity of Usher syndrome type II: localisation to chromosome 5q. *J Med Genet* 2000;37: 256-262.
- 40 Joensuu T, Hämäläinen R, Yuan B, Johnson C, Tegelberg S, Gasparini P, Zelante L, Pirvola U, Pakarinen L, Lehesjoki A-E, de la Chapelle A, Sankila E-M. Mutations in a novel gene with transmembrane domains underlie Usher syndrome type 3. *Am J Hum Genet* 2001;69:673-684.

# 3.4

---

## ANALYSIS OF OPTOKINETIC AND VESTIBULAR RESPONSES RELATED TO ADVANCING AGE AND INCREASING VISUAL IMPAIRMENT IN USH2a

P.L.M. Huygen  
R.J.E. Pennings  
M.G.M. Nicolassen  
A. van Aarem  
M.D. Weston  
A.F. Deutman  
W.I.M. Verhagen  
H. Kremer  
W.J. Kimberling  
C.W.R.J. Cremers

Experimental Brain Research 2004, submitted



## INTRODUCTION

### *Usher syndrome in general*

The general prevalence of Usher syndrome is estimated to be 3.5-6.2 per 100,000.<sup>1</sup> Worldwide it is the most common cause of deaf-blindness accounting for more than 50% of the deaf-blind population<sup>2</sup> and for 3-6% of the congenitally deaf population.<sup>3</sup> Characteristic features are sensorineural HI, retinitis pigmentosa (RP), or pigmentary retinopathy and, in some cases, vestibular dysfunction.

Table 1. Genetic subtypes of Usher syndromes

Subtype	Chromosome	Gene	Prevalence
USHER TYPE I			
USH1a	14q32		2%
USH1b	11q13.5	<i>MYO7A</i>	60%
USH1c	11p15.1	<i>USH1C</i>	5%
USH1d	10q21-22	<i>CDH23</i>	20%
USH1e	21q		Rare
USH1f	10q21.1	<i>PCDH15</i>	10%
USH1g	17q24-25	<i>SANS</i>	Rare
USHER TYPE II			
USH2a	1q41	<i>USH2A</i>	80%
USH2b	3p23-24.2		Rare
USH2c	5q14.3-21.3		15%
USHER TYPE III			
USH3	3q21-25	<i>USH3</i>	Rare

The Usher syndrome has been classified into three different types on the basis of audiovestibular findings.<sup>4</sup> Usher syndrome type I is characterised by profound HI and vestibular areflexia, Usher type II by moderate to severe HI and intact vestibular function, and Usher type III by progressive HI and generally intact vestibular function. Genetic classification occurs by genotype on the basis of the identification of the chromosomal loci and the responsible genes; the first part of the name of each genetic subtype (USH1, USH2 or USH3) reflects the clinical classification (Table 1). At this moment at least 11 loci are known to be involved in Usher syndrome and 7 genes have been identified (Table 1).<sup>5</sup> The most prevalent genetic subtypes of Usher syndrome are Usher syndrome type Ib (USH1b) and Usher syndrome type IIa (USH2a), accounting for approximately 60% and 80% of Usher type I and Usher type II cases, respectively.

### *Usher syndrome type IIa*

In 1990 USH2A was linked to chromosome 1q41.<sup>6</sup> The identification of the *USH2A* gene was reported by Eudy et al. (1998).<sup>7</sup> Still little is known about the function of usherin, the *USH2A* protein transcript. It is a basement membrane protein, which is expressed in the capillary and structural basement membranes of the human and murine retina and in the murine inner ear from birth into adulthood. It is believed to be critical for normal development and tissue homeostasis in the inner ear and retina.<sup>8</sup>

USH2a patients are characterised by moderate to severe downsloping sensorineural HI, with mild progression by about 0.5 dB per year.<sup>9,10</sup> Visual deterioration has been evaluated in several studies on Usher type I and II patients.<sup>11-15</sup> In USH1b and USH2a patients, RP leads to a progressive decrease in visual acuity (VA) and visual field size with advancing age.<sup>16</sup>

### *Aim of present study*

Although, by definition, patients with Usher syndrome type II have intact vestibular responses,<sup>4</sup> it was noticed during ongoing Usher studies that Usher type II patients seldom appeared to have fully normal vestibulo-ocular reflex (VOR) parameters. We wondered whether any systematic changes in VOR parameter values could be found in the Usher type II patients, who later became identified as USH2a patients. If so, it might be possible to establish a relationship between changes in the VOR, optokinetic nystagmus (OKN) or optokinetic after nystagmus (OKAN) responses and deteriorating visual functions.

## METHODS

### *Patients*

This study comprised 29 Dutch USH2a patients that underwent vestibulo-ocular examination with electronystagmography and computer analysis. After informed consent had been obtained, clinical examination of affected individuals was performed consisting of medical history taking and audiovestibular and ophthalmological examinations. Ophthalmological examinations consisted in most patients of a complete eye examination (corrected VA measurements, Goldmann

perimetry, slit-lamp ophthalmoscopy, electro-oculography and electroretinography). The results of these examinations confirmed the diagnosis of RP in all affected individuals. In addition, the patients were diagnosed to have Usher syndrome type II on the basis of vestibular responses and specific audiometric features. Twenty patients came from 9 multi-affected families, whereas 9 patients were the only affected individuals in their family.

#### *Molecular genetics*

Blood samples were collected from all patients and their non-affected relatives for linkage and mutation analysis. All Usher syndrome type II patients included in this study were diagnosed to have USH2a on the basis of a pathogenic mutation in at least one allele within the *USH2A* gene. Five different mutations (R317R, W409X, C419F, C536R, and E767fs) were identified. In 11 patients an *USH2A* mutation was found in only one allele and in 18 patients homozygous (n=7) or compound heterozygous (n=11) mutations were identified. The truncating mutations were classified as inactivating mutations (i) and the amino acid residue substitutions were classified as non-inactivating (ni) mutations. Given a general lack of sufficient numbers of patients with similar mutations, the analyses mainly compared different classes of mutations, indicated as: i/i, i/ni, ni/ni, i/? and ni/?.

#### *VA and visual field evaluation*

To evaluate visual impairment, the functional acuity score (FAS), the functional field score (FFS) and the functional vision score (FVS) were used from the AMA Guides 5<sup>th</sup> ed.<sup>17</sup> VA was measured according to common standards by using Snellen charts in 23 of the 29 patients. Best-corrected measurements of each eye separately and both eyes combined were used to derive the FAS. The visual field measurements were performed by Goldmann perimetry of both eyes and included isopter evaluation at the V-4 target in most cases and in a number of cases the III-4 and I-4 targets. The Goldmann perimetric fields were quantified for each eye separately and both eyes combined by plotting the III-4 isopter, which was measured in 16 of the 29 patients that were analysed, and thus the FFS was derived. It is important to realise that the FVS is a score combining both the VA and visual field scores, i.e.  $FVS = (FAS \cdot FFS) / 100$ , and that both the FAS and FFS are defined for binocular vision.<sup>17</sup>



*Oculo-vestibular testing*

The patient was seated in upright position in a rotatory chair at 1.20 m in front of a hemicylindric screen. Electronystagmography was employed with computer analysis of the nystagmus slow phase velocity (SPV). As the corneoretinal potential is strongly reduced in many of these patients, it proved to be important that sufficient amplification was applied with appropriate filtering to avoid noise and artefacts. On the other hand, as dark adaption is lacking in these patients, the corneoretinal potential was remarkably stable. Horizontal angular eye positions were calibrated before each test, using bright red LEDs under direct visual control of an observer. In the patients with very poor VA, calibration was aided by using tactile enforcement: the observer took the patient's index finger and guided it to the intended position to touch the correct LED. Because in such a situation blind or nearly blind patients often tend to show initial overshooting of the target, the eye position record was read off when the observer noticed that the patient's eyes were on target. It was examined whether spontaneous nystagmus was present in the light or in complete darkness with eyes open. The latter condition was also used in vestibular tests. Lateral eye positions were screened for gaze-evoked nystagmus in the light.

Binocular bidirectional OKN responses were elicited at 40°/s and 60°/s constant velocity stimulation by moving shadows ( $n = 24$ , 7.5° wide at 7.5° separation) projected onto the screen. Only a relatively short stimulus duration with an equivalent analysis interval of 10 s or less was used with abrupt velocity steps and direction transitions in order to mainly address the cortical OKN system ("direct OKN pathway", see Ilg 1997 or Leigh and Zee 1999 for review)<sup>18,19</sup>. Monocular bidirectional OKN was elicited in 6 patients using 40°/s constant velocity stimulation with similar velocity steps at short intervals as used for eliciting binocular OKN. The OKN response level was characterised by the mean SPV of a representative steady-state part of the response profile. Smooth pursuit was not formally tested as it proved to be difficult for many of the patients with small visual fields to capture the visual target and it was anticipated that poor VA might account for additional visual tracking problems in many of them. OKAN was elicited (in 7 patients) by whole-body rotation at 50°/s in two directions. Loading was performed by constant rotation at this velocity in full light for one minute to address the subcortical OKN system with its "velocity storage mechanism" (for review, see Ilg 1997 or Leigh and Zee 1999)<sup>18,19</sup>, after which rotation continued at

the same velocity, the lights were switched off (experimental time zero) and OKAN was recorded. Computer analysis of OKAN responses was performed in 5 patients. The first few seconds of the nystagmic response in darkness were discarded, but the estimated initial velocity ( $V_{OKAN}$ ) still pertained to SPV extrapolated to experimental time zero.  $V_{OKAN}$  and the dominant OKAN time constant ( $T_{OKAN}$ ) were calculated by regression analysis from the SPV profile during decay after loading, similar to velocity-step responses.<sup>20</sup> In addition, cumulative (slow-phase) eye displacement during OKAN ( $CED_{OKAN}$ ) was measured from the chart recording using a paper and pencil method to also include the 2 patients whose OKAN response was not analysed by computer. The geometric mean of  $V_{OKAN}$ ,  $T_{OKAN}$  and  $CED_{OKAN}$  for the two nystagmus directions was derived (see reason below) from each patient's response for further analysis. The across-subjects median and range were determined. The monocular OKN responses were only qualitatively evaluated to check whether they were approximately similar in level and bidirectional symmetry to the binocular OKN responses.

Previously established normal values for OKN responses were used that had been obtained from 99 subjects. They had normal vision and normal, quantitatively evaluable OKN responses, were not taking any drugs that might have influenced their responses, had intact vestibular responses and ages that were homogeneously distributed across a broad range (14 - 72 years, mean 41.3 years). The mean response level at 40°/s stimulation was 37.6 °/s and did not show a significant correlation with age. The mean response level at 60 °/s stimulation was 50.5 °/s, however, the latter showed a significant correlation with age ( $r = 0.346$ ,  $P = 0.0005$ ) with a downward slope of  $-0.15$  °/s per year. The 95% prediction interval for the regression lines was derived to determine which of the OKN responses in the Usher syndrome patients were within normal limits (Figure 5).

The OKN responses obtained from the USH2a patients were also compared to the responses separately obtained from a group of patients having a fairly similar type of progressive visual impairment but no functional VOR. For this purpose we used the data obtained with exactly the same method and conditions from 33 Usher type I patients with confirmed vestibular areflexia, 23 of whom had been genotyped (18 USH1b and 5 USH1d). Part of these data have been previously reported.<sup>21</sup>

The VOR was evaluated using velocity step tests of 90°/s and binaural caloric tests with water irrigation. The velocity step response parameters analysed were those previously established.<sup>20</sup> Their 90% confidence interval (CI) had been established by Theunissen et al. (1986)<sup>22</sup>: initial velocity (V), time constant (T) and *Gesamtamplitude* ( $G = VT$ , equivalent to cumulative eye position, see Huygen and Nicolassen 1985)<sup>20</sup>. The 90% CI was adapted for using the mean value calculated for each response parameter for the right-beating and the left-beating nystagmus responses, see Table 2 below. It should be noted that the parameters V, T and G all have lognormal distributions<sup>22</sup> and that for this reason the geometric mean was calculated. Significant directional preponderance (DP), i.e. beyond the 95% CI, was defined as a relative (percentual) difference (i.e. absolute value) in a given velocity step parameter (V, T or G) between the two nystagmus directions of > 28% for V, > 25% for T and > 22% for G.<sup>22</sup>

#### *Caloric responses*

The caloric test was performed with the patient in a recumbent position, the head elevated by 30° from the earth horizontal, with the stimulus conditions and analysis as previously described.<sup>23</sup> Bithermal (30 and 44°C) water irrigation (150 ml in 20 seconds) was employed. The response parameter was the mean SPV of the postcaloric response at culmination. Bilateral caloric weakness was concluded to exist if the level of all single responses from either ear (at culmination) was < 7°/s. Unilateral caloric weakness was concluded to exist if either there was no response at all or hardly any response from one side, or when the side difference, i.e. the percentual difference in response level between both sides as defined for 4 irrigations, was > 20% (assumed normal limit). Caloric DP was not evaluated, because only a relatively small proportion of the patients had binaural bithermal caloric irrigations. The (arithmetic) mean binaural caloric response level was used for further analysis.

#### *Statistical analyses*

Plots were prepared and statistical analyses and tests performed with a commercial program (Prism 3, GraphPad, San Diego, CA, USA). Linear regression analysis was used to detect significant correlation coefficients (Pearson's  $r$ ). Partial correlation coefficients were calculated where possible, within the same data set, to find out whether any spurious correlations could be identified. Comparisons between regression lines were performed using a type of analysis similar to

---

analysis of covariance (ANCOVA). Nonlinear regression analysis was only used to arbitrarily fit a dose-response curve with variable slope to the OKN response levels plotted against age. Binomial distribution statistics were used to test whether the proportion of (a combination) of significantly high or low response parameter values was high enough to indicate a significant finding (i.e. tail probability,  $P < 0.05$  in the corresponding binomial distribution). The level of significance generally used in the tests was  $P = 0.05$ .

## RESULTS

### *Binocular OKN findings*

The bidirectional mean OKN response levels at ages below 45 years were normal (Figure 1, see also Figure 5A below) compared with the normal OKN responses obtained from routine vestibular examinations (Methods). Above that age a substantial decline in OKN response was found. OKN responses could not be elicited in 2 patients with very poor vision. Relative to their age (51 and 53 years), their poor OKN responses may have been in line with the general deterioration of these responses at a more advanced age, as is shown in Figure 1. Most of the patients with very poor OKN responses did not have formal functional vision scores (as indicated by special symbols in Figure 1), however, crude VA and/or field measurements (data not shown) were available from previous examinations.

A significant negative correlation between OKN response level and age was found (Figure 1). As will be elaborated below, the correlation between the OKN response level at  $60^\circ/\text{s}$  and age (i.e. at age  $< 50$  years) vanished when partialing out T (Table 3).

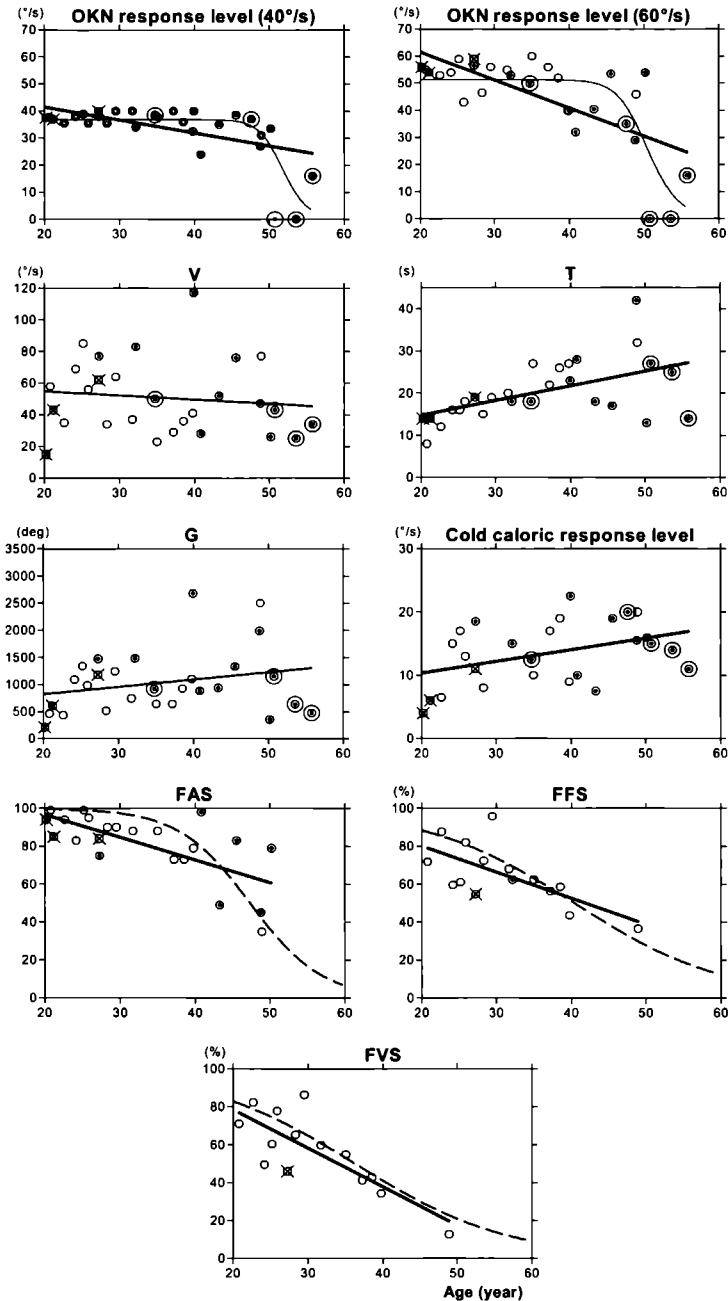

Figure 1 Plots of individual response parameter values (small circles) against age. Small circle combined with a cross represents patient with probable peripheral vestibular impairment (unilateral or bilateral caloric weakness). Regression lines are shown in bold for significant correlations. Curves in top panels were arbitrarily fitted (Methods). Small circle marked by a dot inside indicates patient with an incomplete set of functional vision scores, small circle marked by a larger concentric circle indicates patients without any functional vision score evaluation. Dashed curves in 3 bottom panels indicate trends derived from individual longitudinal analyses by Pennings et al.<sup>16</sup>

*Monocular OKN and OKAN findings*

Monocular OKN showed the same response level as binocular OKN and was bidirectionally symmetric. OKAN was easily elicited from each patient that was tested. The median  $V_{OKAN}$  was  $27^\circ/s$  (range  $18-39^\circ/s$ ), the median  $T_{OKAN}$  17 s (range 3-35 s) and the median  $CED_{OKAN}$   $375^\circ$  (range  $65-650^\circ$ ).

*VOR and functional vision score findings*

One patient showed VOR responses that were not reliable enough for quantification in either nystagmus direction. In the other patients, DP measures for V, T and G were only evaluated if no unilateral caloric weakness was found (Table 2), however, caloric tests were not always bithermal and not obtained in all patients.

Table 2. Statistics for (binaural mean values of) VOR-related parameters. Bold values, significantly high proportion of finding according to binomial distribution statistics.

Parameter	Velocity-step response			Cold caloric response level
	V	T	G	
95% CI	33-58°/s	13-23 s	545-1000°	12-37°/s
S high value (N=28 <sup>a</sup> or 26 <sup>b</sup> )	9	8	12	0
Normal value	13	18	10	16
S low value	6	2	6	10
	[5 of 24] <sup>c</sup>	[2 of 24] <sup>c</sup>	[5 of 24] <sup>c</sup>	
Unilateral weakness (see text) (N=27)				2
Bilateral weakness (see text)				1
S DP (N=25 <sup>d</sup> )	1	5	7	

<sup>a</sup>, velocity step test ; <sup>b</sup>, caloric test; <sup>c</sup>, excluding unilateral and bilateral weakness and cases without caloric test; <sup>d</sup>, excluding unilateral weakness and cases without caloric test; CI, confidence interval; DP, directional preponderance; G, *Gesamtamplitude* (cumulative eye displacement), N, total number of quantifiable responses; S, significant ( $P < 0.05$ ), T, time constant of VOR; V, initial velocity

VOR responses were found in all patients, but they were fully normal in only 1 of the 26 patients in whom both velocity step and caloric responses could be evaluated. Table 2 shows that significantly high values of the parameters V, T and G occurred significantly more often than could have been expected on the basis of chance alone. This also applied to significantly low values, except for T, even if cases with probable peripheral vestibular impairment were excluded. Caloric test results also showed significantly low values in significant proportion, although neither unilateral nor bilateral pathological caloric weakness was a significant

finding. Significant directional preponderance values were found in significant proportion for the velocity step parameters T and G (Table 2).

Figure 1 shows a significant decrease not only in OKN response level but also in the FAS, the FFS and the FVS, as well as a significant increase in T and caloric response level with advancing age. It was remarkable that in a separate study on progressive visual impairment in USH2a patients, part of whom also participated in the present study,<sup>16</sup> the results of individual longitudinal analyses indicated a higher rate of deterioration of the functional vision scores, especially the FAS, than did the results of the concomitant or the present cross-sectional analysis. Also, the visual impairment study covered higher ages of the patients than the present one. It is therefore important to invoke the trends (dashed curves in bottom panels of Figure 1) derived from the longitudinal analyses performed in that study for the sake of comparison (Discussion).

Linear regression analysis seemed to be appropriate as a first step towards (partial) correlation analysis in the case of every parameter covered by the panels in Figure 1, except when OKN response levels were involved. These response levels showed a fairly linear relationship to age with only minor decay at ages < 50 years, but an apparently much more rapid decay at higher ages, constituting a nonlinear relationship. This relationship, together with a bias in missing values, i.e. the fact that especially the older patients tended to have an incomplete set of functional vision scores or no such scores at all evaluated, prohibited straightforward (partial) correlation analysis. The relationship between OKN and age was further explored by distinguishing 4 (sub)categories of patients (Figure 2). Category 1, all data whatsoever included, no matter whether or not functional vision scores had been assessed (n = 28-29 for oculo-vestibular responses, small circles in Figure 1); category 2, complete data set (n = 13-14, except for caloric response; unmarked small circles in Figure 1); category 3, not all functional vision scores measured (n = 13-14, symbols marked with dot inside in Figure 1); category 4, no functional vision score at all evaluated (n = 4-5, symbols marked with large circle in Figure 1). The regression lines (labeled 1-4) corresponding to these categories are included in Figure 2. The slope of the regression line becomes steeper when going from category 2 (patients with all key parameters measured) through 3 (not all of the visual parameters evaluated) to 4 (no visual parameters evaluated). ANCOVA was performed where appropriate, i.e. only when comparing between the mutually exclusive categories 2 and 3, or 2 and 4, to find

out whether there were significant differences between regression lines. Indeed, there was a significant difference found between the regression lines for categories 2 and 4 (Figure 2A). The (significant) differences in slope largely disappeared when patients older than 50 years of age were excluded (Figure 2B), in line with the observation that the diminished OKN responses were associated with advanced age. There was also an association with poor visual function (data not shown), as was already mentioned above.

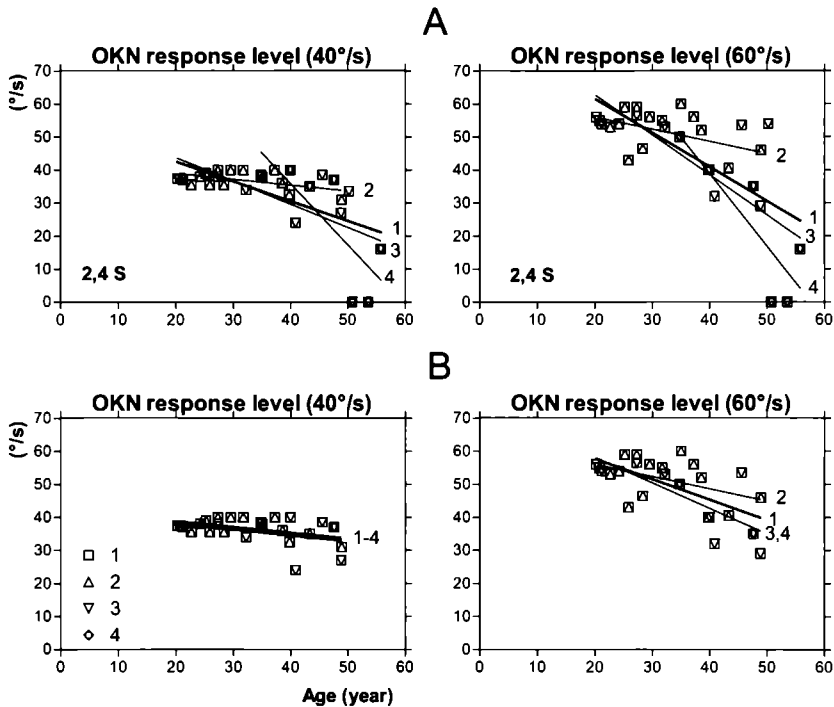

Figure 2a,b Same as top panels in Figure 1, now with different symbols (symbol keys in bottom left panel pertaining to categories of patients and regression lines labeled 1-4, including all patients (A), or including only the patients below 50 years of age (B). Category 1, all patients ( $n = 28-29$  for oculo-vestibular responses); category 2, patients with a complete data set ( $n = 13-14$ , except for caloric response), category 3, not all functional vision scores evaluated ( $n = 13-14$ ); category 4, no functional vision score at all evaluated ( $n = 4-5$ ). The expression 2,4 S indicates that regression lines 2 and 4 were significantly different (Methods).

Invoking partial correlations for further analysis is only valid within the context of a complete set of data. We therefore decided to perform such an analysis only within either category 1 for the vestibulo-ocular response parameters, or within



category 2 with a complete set of data comprising VOR parameters and functional vision scores. Given the above described nonlinearity pertaining to the OKN response levels at age > 50 years, we also decided to perform (partial) correlation analyses within category 1 involving age, OKN response levels and T only for ages of < 50 years, without invoking functional vision scores (Table 3).

Table 3. Effect of partialing out any of the parameters indicated (columns) on significant correlations (rows) involving OKN60\*, T and age in category 1 patients (presence or absence of functional vision scores ignored) aged < 50 years.

Significant Correlation	Controlling for:		
	Age	OKN60	T
OKN60xAge			vanishes
OKN60xT	vanishes		
TxAge		persists	

\*, OKN60 denotes OKN response level at 60°/s stimulation

#### *Intercorrelations between response parameters*

Some significant correlations between response parameters (data not shown) were obviously trivial. These included the correlation between the OKN response levels at 40 and 60°/s stimulation, the correlation between the caloric response level and the gain-related VOR parameters V and G, as well as the correlation between either V or T and G (data not shown). As the OKN response level at 40°/s stimulation behaved fairly similarly to the one at 60°/s stimulation, only the latter was included in further (e.g. partial correlation) analyses. Similarly, the parameters G and caloric response level were no longer considered next to T.

Of major importance to the present study are the relationships between either the OKN or VOR response parameters on the one hand and the visual parameters on the other hand (Figures 3-4). In the plots in Figures 3 and 4 T, the FAS, the FFS and the FVS replace age (Figures 1-2) as independent variable.

Figure 3A shows that the OKN response level at 60°/s seemed to correlate significantly with T, no matter whether the 3 patients with clearly outlying poor response levels were included (solid bold regression line) or excluded (bold dashed regression line). The OKN response level at 40°/s only showed a significant correlation with T if the 3 patients with the poorest responses were excluded (dashed bold regression line). As indicated in Figure 3A, none of the latter patients had a formal evaluation of any of the functional vision scores; they therefore belonged to the above defined category 3 and 4 patients.

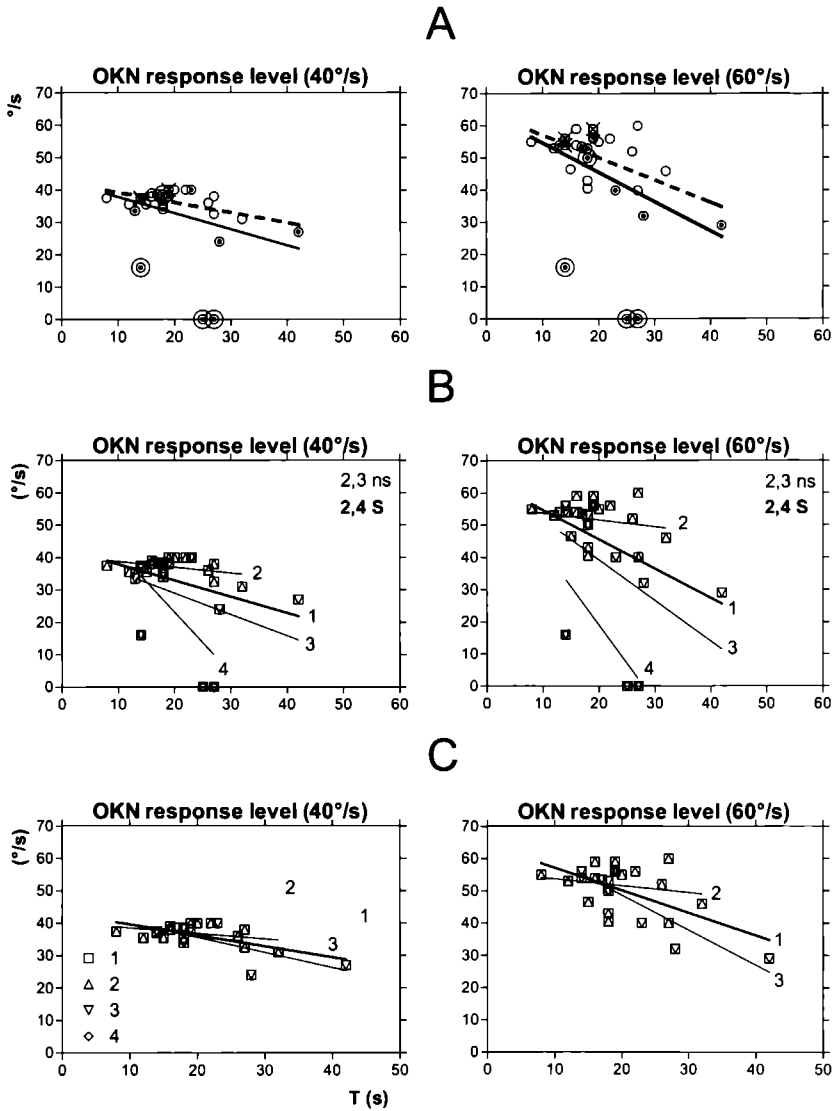

Figure 3 a,b,c. Same as two top panels in Figure 1, with T replacing age as “independent” (X) variable for all data (A), with different symbols and regression lines (B, C) for the categories of patients 1-4 (Figure 2) for all data (B), and for the patients below 50 years of age (C). A: The solid regression line pertains to all data points including outlying values (response level < 20°/s); the dashed regression line pertains to the data points excluding these values. Symbols marked similar to Figure 1. B and C: details similar to Figure 2 A, B. ns, not significant; S, significant.

Exploring the relationship between OKN response level and T further, it appeared (similar to Figure 2A) that the regression lines showed increasing negative slopes from category 2 through 3 to 4, again with significant differences between the regression lines pertaining to the categories 2 and 4 (Figure 3B). The differences between the categories largely disappeared when including only patients aged below 50 years (Figure 3C). It thus showed that also the analysis of the correlation between OKN response level and T could be best performed within category 1 at ages of < 50 years. The significant correlation between OKN response level and T vanished when controlling for age (Table 3).

Table 4 Effect of partialing out any of the parameters indicated (columns) on significant correlations (rows) involving T, age (mean 32, range 20-49 years), the FAS, FFS and FVS in category 2 patients (all functional vision scores evaluated)

Significant Correlation	Controlling for.			
	Age	FAS	FFS	FVS
TxAge		persists	persists	persists
TxFAS	vanishes		vanishes	na
TxFFS	vanishes	vanishes		na
TxFVS	vanishes	Na	na	

na, not applicable because of the arithmetic relationship between the FVS and both the FAS and the FFS (Methods)

Figure 4 shows OKN response level and T plotted against the FAS (A), the FFS (B), or the FVS (C). The OKN response levels did not show any significant correlation with any of these scores (Figure 4). However, it should be kept in mind that the category of patients involved, i.e. category 2 comprising the patients who had all relevant measurements (n = 15), constituted a selection of the patients by age. The older ones with diminished OKN response levels (Figure 1) generally had no complete set of functional vision scores evaluated. For this reason, it seems likely that the correlation between OKN response levels and functional vision scores was biased: correlations involving OKN response levels have therefore been omitted from Table 4.

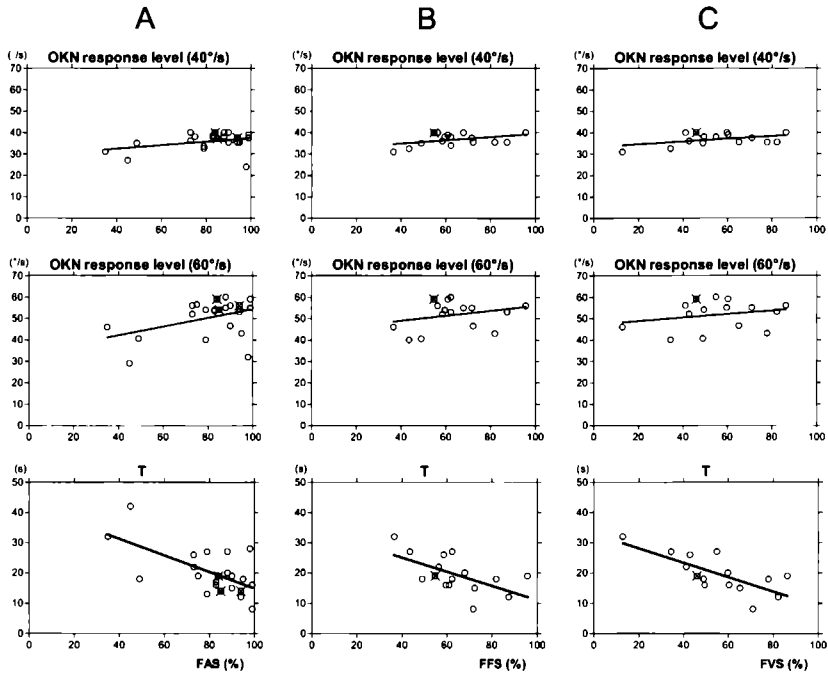

Figure 4 a,b,c. First two rows of panels similar to top panels in Figure 1, bottom panels similar to the panel for T in Figure 1, now with the FAS (A), the FFS (B) or the FVS (C) instead of age as independent variables.

There was a significant positive correlation between T and age (Figure 1) that persisted when controlling for the OKN response level at 60°/s stimulation (Table 3), the FAS, FFS or FVS (Table 4). The significant negative correlation between T and either the FAS, the FFS or the FVS (Figure 4) vanished when partialing out age. The correlation between T and the FAS (Figure 4A) vanished when controlling for the FFS and the same applies to the correlation between T and the FFS (Figure 4B) when controlling for the FAS (Table 4).

It should be emphasised that correlations involving the parameter T appear in both Table 3 and 4 in two different settings, i.e. bearing on category 1 patients aged < 50 (Table 3) or category 2 patients who had all key parameter values assessed (Table 4). As already explained in relation to Figures 1 and 3, it had been checked that the correlation coefficients involving T related to compatible features of the regression analyses in both categories.

*Findings related to specific mutations or the type of mutations*

A systematic analysis was performed along the same lines as described above to see whether any of the findings were related to certain types of mutations. There were no substantial differences found (data not shown) between the responses of patients with inactivating or non-inactivating mutation combinations, or between any subgroups of patients with any specific mutation(s).

## DISCUSSION

*Recapitulation of findings*

From the first patients with Usher type II we examined - more than 15 years ago - onwards, we were impressed by the variability in VOR findings. According to the clinical definition of Usher type II, the VOR was intact, but the patients seldom showed normal responses. Any abnormal value, high or low, seemed possible for the VOR parameters to occur and we could not discern any system in the variations observed for many years. Below it will be attempted in separate sections to find possible explanations for the observed parameter changes, some of which seemed to be associated with visual function deterioration.

As anticipated, the binocular OKN responses deteriorated with increasing age and the same applies to the functional vision scores, i.e. the FAS, FFS and FVS (Figure 1). There was no finding to suggest a relationship between the decrease in OKN response levels and the decrease in either of the functional vision scores (Figure 4). However, as elaborated above, the limited number of patients ( $n = 15$ ) who had both OKN response levels and functional vision scores evaluated did not cover a representative age range or an appropriate range of OKN response levels. Despite the different age ranges, there was no apparent discrepancy detected in VOR parameter values between the category (2) of patients with all relevant measurements ( $n = 15$ ) and the whole group of patients (category 1,  $n = 28$  or  $29$ ). It therefore seemed justified to study correlations involving T within the two different patient categories 1 and 2 (Tables 3-4). There was a surprising increase in T value found with increasing age (Figure 1) and decreasing functional vision scores (Fig 4), it also appeared that the OKN response level decreased with increasing T value (Figure 3). Monocular OKN and OKAN responses are recapitulated below.

---

*VOR parameter values*

The present analyses demonstrated that abnormal high or low values of (some of) the VOR parameters V, T and G occurred more often than could have been anticipated on the basis of chance alone (Table 2). Some of our patients were spectacle wearers, most of them being myopes, but they were not allowed to use their glasses during calibrating and testing. We checked the effect of applying the appropriate corrections for VOR gain, which comprise a binocular combination of the precise spherical and cylindrical refraction corrections of the patient's glasses, such as has been previously outlined by Cannon et al. (1985).<sup>24</sup> Correction produced only minor changes in gain estimates that did not affect the classification of the response parameter values according to significantly low or high values shown in Table 2.

We have no conclusive explanation for the finding that significantly low values of the response parameters V or G and the caloric response level, or the significant DP detected for the parameters T and G, occurred in significant proportions (Table 2). Low values of V, T or G may be related to peripheral labyrinthine impairment.<sup>20</sup> For this reason, we highlighted the data points representing the patients who showed unilateral or bilateral caloric weakness in some of the figures, but it seemed that the number of such cases did not suffice to explain the high proportion of low response parameter values (note <sup>c</sup> to Table 2). It can be suggested that the high proportion of low caloric response levels (Table 2) would indicate a tendency towards poor peripheral vestibular function, even in cases where the criteria for diagnosing pathological unilateral or bilateral caloric weakness were not met.

Part of the high T values might be explained by the tendency of T to increase with increasing age and increasing visual impairment (Figures 1 and 4). The same tendencies were shown to some degree by the parameter G (shown in Figure 1 in relation to age, other data not shown). Although the parameter V showed a slight tendency to decrease with advancing age (Figure 1), it also showed at least some tendency to increase with increasing visual impairment as covered by the FAS and the FFS (data not shown). So it seems possible that all 3 VOR parameters had some tendency to increase their value in association with increasing visual impairment. The clearest tendency, however, was shown by the VOR time constant T.

*OKN response level, age and T*

The OKN response level decreased with advancing age (Figure 1) and increasing value of T (Figure 3). The correlations between OKN response level and age or T may have been spurious ones because they vanished when controlling for T and age, respectively (Table 3). However, it should be kept in mind that the limitation of age < 50 years excluded most, if not all, of the relevant decrease in OKN levels associated with visual impairment. Therefore, even if a significant correlation between OKN response level and age or T had been found to persist after partialisation, this would not have produced any relevant information regarding the age and impairment ranges of interest. Nevertheless, it was obvious that OKN response levels deteriorated dramatically at age > 50 years (Figure 1). Looking for a possibly concomitant trend in functional vision scores, we considered the trends obtained from longitudinal analyses in the study by Pennings et al. (2004)<sup>16</sup> that are also depicted in Figure 1 (bottom panels, dashed curves). Only the FAS showed a similar type of nonlinearity, i.e. a clear transition to a more rapid deterioration from about the age of 40 years onwards. Thus, the decline in OKN response level lagged behind the major decline in the FAS (Figure 1). A steady decline in the FFS and FVS is seen all over the age range of 30-50 years. It can be also conceived that gradually increasing visual impairment would appreciably affect OKN response levels only once a critical level of impairment has been attained that pertains to a critically low value of the retinal slip gain. Such a bottleneck might be reflected by an apparent transition in the graphic relationship between OKN response level and age. The latter might be even more tangible if during the gradually increasing visual impairment some regulatory or homeostatic mechanism would be active to maintain a normal OKN level for as long as possible. Comparison between the OKN response levels measured in our USH2a patients and the normal limits obtained at our laboratory (Methods) clearly showed that at ages below 45 years all patients had normal OKN response levels (Figure 5A). It should be emphasised that they were still having these normal OKN response levels whilst they were already developing a considerable degree of visual impairment (Figure 1).

Given the notion that mainly the cortical OKN system must have been involved, it is opportune to invoke the mechanism of optokinetic training<sup>25</sup> as a possible explanation. Previous studies have shown that OKN training not only enhances OKN response levels but also the VOR.<sup>26,27</sup> We speculate that OKN enhancement

in the USH2a patients resulted in seemingly normal OKN response levels despite the already declining optokinetic system, and that concomitant enhancement of an intact VOR has led to apparent vestibular hyperreactivity

It is also possible that the intriguing phenomenon of cortical filling-in is involved Valmaggia and Gottlob (2002)<sup>28</sup> described 3 patients with age-related macular degeneration with a large (15-18° diameter) central scotoma caused by an occult subfoveal neovascularization While looking at the OKN stimuli, the patients either did not see the stimulus and produced minimal OKN, or filled in the scotoma and perceived the stripes, which then elicited OKN with a normal gain Voluntary switching between the two conditions was possible At a repeat examination 1 year later, the patients continuously perceived the OKN stimulus and produced OKN during the entire test Similarly, in a previous study, all patients, whatever the size of their scotoma, constantly perceived the OKN stimulus and exhibited OKN<sup>29</sup> Such features may be explained by long-term cortical adaptation In these patients, filling-in of their central scotoma must have taken place starting from more peripheral parts of the retina One wonders as to whether a similar type of filling-in phenomenon of peripheral scotomas can occur that originates from the more central part of the retina If that is the case, especially patients with advanced RP might experience its action

*(Other) correlations involving the VOR time constant*

The VOR time constant T further showed correlations with age (Figure 1), the FAS (Figure 4A), FFS (Figure 4B) and FVS (Figure 4C) All of the latter 3 correlations vanished when controlling for age The correlation between T and age persisted when controlling for any of the functional vision scores (Table 4) or the OKN response level (Table 3) and therefore seems unlikely to have been secondary to visual impairment or changes in OKN responses When controlling for any one of the 2 variables FAS or FFS, the correlation between T and the remaining variable vanished (Table 4) It therefore seems reasonable to assume that the 3 variables T, FAS and FFS were in some way associated, although the correlations between T and the functional vision scores may have been spurious ones, because they vanished when controlling for age (Table 4) The constellation of these findings favours an interpretation in terms of an increase in T secondary to the deterioration of visual function with advancing age However, again, there were insufficient data bearing on parameter behaviour at age > 50 years (Figure 1)



*Monocular OKN and OKAN*

No substantial difference in response characteristics between bidirectional, binocular OKN and monocular OKN responses was found. In particular, we could not find any temporo-nasal asymmetry. This finding, which is similar to a previous finding reported in patients with RP by Heide et al.<sup>30</sup>, favours the notion that mainly the cortical OKN system was involved in the present OKN responses, that were elicited with velocity-step stimuli with only a short duration of constant velocity.

We compared our OKAN responses to those reported by Simons and Büttner<sup>31</sup> for normal subjects that were obtained with fairly similar stimulus equipment and conditions as used in our patients. It appeared that the initial OKAN velocities in our USH2A patients matched well with those specified for their normal subjects of similar ages. This contrasts with the findings obtained by Heide et al.<sup>30</sup> from their RP patients (aged 23-56 years with a remaining central visual field with a horizontal diameter in the range of 18-50°). It seems relevant that the latter authors did not apply whole-body rotation, which is a very effective stimulus for eliciting OKAN, probably more effective than motion of only the visual surround, as was applied by them. It is also possible that some of their RP patients had Usher type I with vestibular areflexia (vestibular examination was not mentioned), a condition in which OKAN cannot be elicited (see Leigh and Zee 1999 for review).<sup>19</sup> OKAN responses depend on the subcortical OKN system (indirect OKN pathway) with its velocity storage mechanism. Given the present results, it is clear that the subcortical OKN system in our patients was intact. Our patients in whom OKAN had been assessed had ages in the range of 23-49 years and a monocular central visual field diameter (Goldmann perimetry with III-4 isopter) of between 18 and 88° (the FFS was in the range of 36-82). Because none of them showed clearly diminished OKN responses (their binocular OKN response levels were in the range of 40-56°/s at 60°/s stimulation), the possibility remains that USH2a patients with diminished OKN responses also have diminished OKAN responses. Nevertheless, if that would be the case, it would not explain our finding of diminished OKN responses, because these were elicited in a way that hardly addressed the subcortical OKN system.

---

*Effect of VA or visual field size on OKN response level*

Obviously, OKN responses are impossible without sufficient VA, but what is sufficient? Monocular OKN cannot be elicited from the affected eye in children with congenital monocular cataracts, however, OKN is intact postsurgery (for example, Ben Ezra and Paez<sup>32</sup>). It has been argued before that VA has only a minor influence on OKN gain when the fundamental spatial frequency can be still resolved.<sup>33</sup> Heide et al.<sup>30</sup> described that VA in their RP patients varied between 0.04 and 0.8 and was thus sufficient to resolve the low spatial frequency of 0.067 cycles/deg. This corresponds to stripes that subtend and are separated by a horizontal visual angle of 7.5°, which is identical to our OKN stimulus. VA in the best eye of our patients was in the range of 0.05-1, except for the 2 patients from whom no OKN could be elicited, who had VA 0.0033 or light perception only. According to the calibration values presented by Weder and Wiegand<sup>34</sup>, OKN is just elicitable from a patient with VA 0.05 if he or she is looking from a distance of 3.75-4.00 m at a pattern of moving light dots projected on a screen at 1 cm diameter and separation. The corresponding visual angle of the stimulus (1 cycle corresponds to 2 cm at 375-400 cm distance) is about 0.3°. The maximum viewing distance for VA < 0.001 is 0.25-0.75 m, which implies that the stimulus (1 cycle of 2 cm) should subtend a visual angle of at least 1.5° to 4.6°, i.e. still sufficient to resolve the stimulus we used (1 cycle subtending a visual angle of 15°).

This does not inform us about the gain of the OKN response to a given suprathreshold stimulus. It is possible that some of our patients at a more advanced age had insufficient VA for optimal resolution of the stimulus, which resulted in a poor OKN response. However, this does not exclude the possibility that their poor OKN response (also) reflected their concomitantly reduced visual field size.

*Functional significance of VOR enhancement*

It can be easily demonstrated that both a high VOR gain and a long VOR time constant, which is associated with a small phase lead (with reference to ideal compensation) at higher frequencies, lead to a reduction of retinal slip, i.e. reduce the retinal slip position (or gaze) error and retinal slip (or gaze) velocity associated with the VOR. However, it seems more relevant to consider retinal slip under the condition of combined visual and VOR stimulation, such as, for example, is brought about by natural head movements. Das et al.<sup>35</sup> and Lee et al.<sup>36</sup> studied the

so called visually enhanced VOR (VVOR) and found considerable enhancement of the VVOR gain, with only minor phase errors, during rotation in the range of natural head movements under normal viewing conditions. The combination of a high VVOR gain and a small phase error produced retinal slip velocities of below  $6^\circ/\text{s}$ . These studies involved interaction between the VOR and the smooth pursuit or the visual fixation system, however, essentially similar enhancement has been found in previous studies combining the VOR and OKN.<sup>37-40</sup> Psychophysical studies have shown that retinal image motion exceeding about  $5-6^\circ/\text{s}$  is associated with declining VA.<sup>41,42</sup> It can therefore be suggested that a reduction in (dynamic) VA in normal subjects elicits the type of VVOR enhancement that was demonstrated by the above mentioned visual-vestibular interaction studies. We speculate that the pre-existent, permanent reduction in (static) VA in our USH2a patients likewise has elicited permanent VOR enhancement. If we suppose that patients with such a type of visual impairment can tolerate more retinal slip than is usual, this may be an advantage because their enhanced VOR, which can be characterised as vestibular hyperreactivity, might otherwise render them especially susceptible to motion sickness. In addition, it has been shown that restricting the field of view reduces the magnitude of optokinetically elicited motion sickness.<sup>43,44</sup>

Given the specific finding of OKN enhancement during VOR stimulation as reported by Koenig et al.<sup>38</sup> and Böhmer and Pfaltz<sup>26</sup>, it also seems possible that in our patients the enhanced VOR helped to maintain OKN at a functional level during natural head movements for as long as possible whilst the visual field was being reduced and therefore retinal slip gain must have been declining. As described in Methods, we took the opportunity to compare the OKN response levels in our USH2a patients to the response levels obtained from Usher type I patients, who have a fairly similar type of progressive visual impairment but lack the VOR. The OKN response levels obtained from the Usher type I patients were normal (Figure 5B) and very similar to those obtained from the USH2a patients (Figure 5A). There was no apparent difference in the type of decline of the OKN response level observed at a more advanced age between the two types of patients. The only apparent difference was that the decline seemed to occur at a slightly lower age in the Usher type I patients (Figure 5B). Admittedly, the numbers of data points bearing on patients (USH2a or Usher type I) of relevant ages, was too small to obtain reliable estimates of the age at which the OKN response level started to decline. However, a certain tendency for a slightly earlier

start of visual impairment in at least the genotyped USH1b patients compared to the USH2a patients was noted to occur in a separate study<sup>16</sup> This is in line with some of the previously reported findings pertaining to comparisons between clinically diagnosed Usher type I and II patients<sup>11 13</sup>

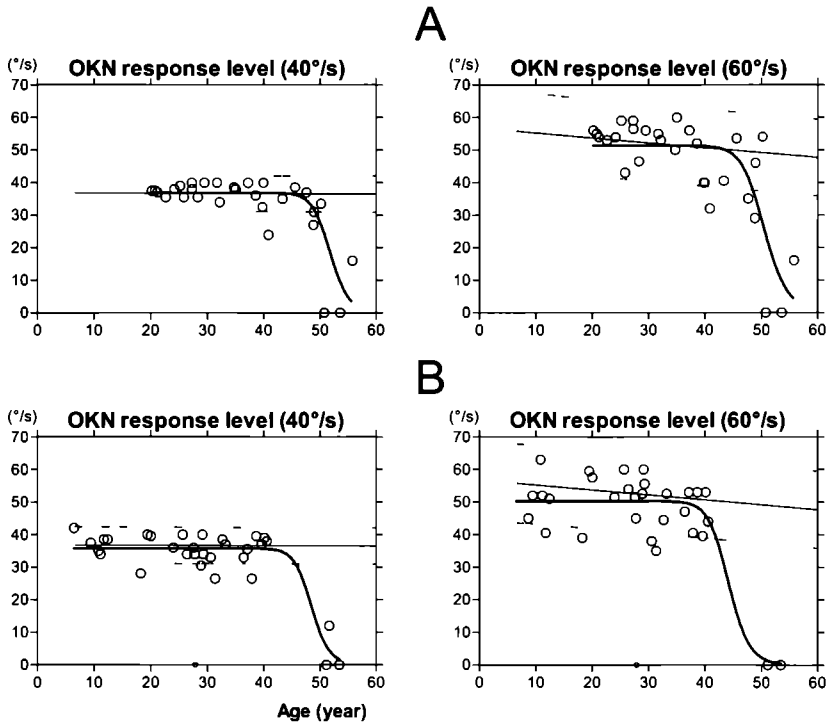

Figure 5 a,b Same OKN data for USH2A as shown in top panels of Fig 1, compared with (B) (unpublished) OKN data of 33 Usher type I patients, 23 of whom had been genotyped (18 USH1B and 5 USH1D) Small symbol, outlying value Straight line with pair of dotted lines represents regression line with 95% hyperbolic prediction interval derived from 99 normal subjects (unpublished data, data points not shown)

Anyway, the comparison between the two types of Usher syndrome illustrated by Figure 5 clearly demonstrates that having a functional VOR was not a necessary prerequisite for the USH2a patients to be able to maintain a functional OKN response level The mere fact that a similar maintenance could also be achieved by (Usher type I) patients who have a fairly similar type of progressive visual impairment but no VOR or a functional subcortical OKN system, confirms that it must be the cortical OKN system and associated cortical mechanisms, more specifically mechanisms that involve learning or training, that play a major role in

maintaining normal OKN response levels for as long as possible. In this context it seems pertinent that a central (parafoveal) part of the retina, which is particularly linked to the cortical OKN system (see Leigh and Zee 1999 for review)<sup>19</sup> keeps functioning, at least partially, in these patients for as long as they are still having a functional level of VA. It seems possible that cortical mechanisms that help tuning the OKN system (and the VOR system?) can afford a lower level of VA than the cortical mechanisms requiring visual fixation and recognition.

Patients with advanced RP are known to have mobility problems<sup>45</sup> and poor mobility behaviour (see also Turano et al.<sup>46</sup> or Li et al.<sup>47</sup> with their references). It is possible that reduced mobility, especially with diminished head movements, has caused a secondary VOR enhancement to develop. We have previously suggested this to be the case in patients with idiopathic spasmodic torticollis,<sup>48</sup> as well as in patients with muscular dystrophy,<sup>49,50</sup> a significant proportion of whom showed an increased VOR gain.

Turano et al.<sup>46</sup> also demonstrated that patients with advanced RP have an increased tendency to look downwards when they walk, which showed a significant negative correlation with their horizontal field extent. Depending on whether the head is inclined in downward direction, or only the eyes are deviated downwards, this might influence the VOR gain. In the primary head position, the horizontal semicircular canals have a forward elevation of about 30°. Downward inclination of the head by 30° would place these canals in an earth-horizontal plane, which would increase the stimulus proper by about 15%, i.e.  $100\%/\cosine(30^\circ)$ . If instead the head would be kept in primary position and only the eyes would deviate downwards, the VOR gain could be decreased, because it is attenuated by a factor equal to the cosine of the angle between the optical axis and the plane of head rotation.<sup>51</sup> If any such change in VOR gain would have been retained during our VOR assessment, it would have only marginally influenced the statistics of significant proportions of some of the significantly high or low VOR parameter values presented in Table 2, thus without affecting the conclusions.

## REFERENCES

- 1 Spandau UHM, Rohrschneider K Prevalence and geographical distribution of Usher syndrome in Germany *Graefé's Arch Clin Exp Ophthalmol* 2002;240 495-498

- 2 Boughman JA, Vernon M, Shaver KA Usher syndrome: definition and estimate of prevalence from two high-risk populations *J Chronic Dis* 1983;36:595-603
- 3 Vernon M Usher's syndrome-deafness and progressive blindness. Clinical cases, prevention, theory and literature survey *J Chronic Dis* 1969;22:133-151
- 4 Davenport SLH, Omenn GS The heterogeneity of Usher syndrome Abstract No 215. Amsterdam Excerpta Medica Foundation, International Congress Series, 1977, No 426, pp 87-88
- 5 Van Camp G, Smith RJH Hereditary Hearing loss Homepage (HHH) World Wide Web URL <http://dnalab-www.uia.ac.be/dnalab/hhh>. Accessed July, 2003
- 6 Kimberling WJ, Weston MD, Möller CG, Davenport SLH, Shudart YY, Priluck IA, Martin A, Smith RJH Localization of Usher syndrome type II to chromosome 1q *Genomics* 1990;7:245-249
- 7 Eudy JD, Weston MD, Yao S, Hoover DM, Rehm HL, Ma-Edmonds M, Yan D, Ahmad I, Cheng JJ, Ayuso C, Cremers CWRJ, Davenport SLH, Möller CG, Talmadge CB, Beisel KW, Tamayo M, Morton CC, Swaroop A, Kimberling WJ, Sumegi J Mutation of a gene encoding a protein with extracellular matrix motifs in Usher syndrome type IIa *Science* 1998;280:1753-1757
- 8 Bhattacharya G, Miller C, Kimberling WJ, Jablonski MM, Cosgrove D Localization and expression of usherin - a novel basement membrane protein defective in people with Usher's syndrome type IIa. *Hear Res* 2002;163:1-11
- 9 Wagenaar M, van Aarem A, Huygen PLM, Pieke-Dahl S, Kimberling WJ, Cremers CWRJ Hearing impairment related to age in Usher syndrome type 1B and 2A, hearing impairment in USH2A is progressive. *Arch Otolaryngol Head Neck Surg* 1999;125:441-445
- 10 Pennings RJE, Huygen PLM, Weston MD, van Aarem A, Wagenaar M, Kimberling WJ, Cremers CWRJ Pure tone hearing thresholds and speech recognition scores in Dutch patients carrying mutations in the USH2A gene. *Otol Neurotol* 2003;24:58-63
- 11 Fishman GA, Kumar A, Joseph ME, Torok N, Anderson RJ Usher's syndrome Ophthalmic and neuro-otologic findings suggesting genetic heterogeneity *Arch Ophthalmol* 1983;101:1367-1374
- 12 Piazza L, Fishman GA, Farber M, Derlacki D, Anderson RJ Visual acuity loss in patients with Usher's syndrome. *Arch Ophthalmol* 1986;104:1336-1339
- 13 Edwards A, Fishman GA, Anderson RJ, Grover S, Derlacki DJ Visual acuity and visual field impairment in Usher syndrome. *Arch Ophthalmol* 1998;116:165-168
- 14 Seeliger M, Pfister M, Gendo K, Paasch S, Apfelstedt-Sylla E, Plinkert P, Zenner H-P, Zrenner E Comparative study of visual, auditory and olfactory function in Usher syndrome. *Graefes Arch Clin Exp Ophthalmol* 1999;237:301-307
- 15 Tsilou ET, Rubin BI, Caruso RC, Reed GF, Pikus A, Hejtmancik JF, Iwata F, Redman JB, Kaiser-Kupfer MI Usher syndrome clinical types I and II: Could ocular symptoms and signs differentiate between the two types? *Acta Ophthalmol Scand* 2002;80:196-201
- 16 Pennings RJE, Huygen PLM, Orten DJ, Wagenaar M, van Aarem A, Kimberling WJ, Cremers CWRJ, Deutman AF Evaluation of visual impairment in Usher syndrome 1b and Usher syndrome IIa *Acta Ophthalmol Scand* 2004 in press
- 17 American Medical Association Chapter 12 The visual system. In Cocchiarella L & Anderson GBJ (eds ) *Guides to the evaluation of permanent impairment*, 5<sup>th</sup> edition. Chicago. American Medical Association Press 2001, 277-304.
- 18 Ilg UJ Slow eye movements *Progr Neurobiol* 1997;53:293-329
- 19 Leigh RJ, Zee DS *The neurology of eye movements* Ed 3, Oxford University Press, New York, 1999
- 20 Huygen PLM, Nicolaisen MGM Diagnostic value of velocity-step responses *ORL J Otorhinolaryngol Relat Specialt* 1985;47:249-261
- 21 Sun JC, van Alphen AM, Wagenaar M, Huygen P, Hoogenraad CC, Hasson T, Koekkoek SKE, Bohne BA, De Zeeuw CI Origin of vestibular dysfunction in Usher syndrome type 1B *Neurobiol Dis* 2001;8:69-77
- 22 Theunissen EJJM, Huygen PLM, Folgering HT Vestibular hyperreactivity and hyperventilation. *Clin Otolaryngol* 1986;11:161-169
- 23 Nijhuis BG, Huygen PLM Single-response variability of air and water caloric reactions *ORL J Otorhinolaryngol Relat Specialt* 1980;42:196-205
- 24 Cannon SC, Leigh RJ, Zee DS, Abel LA The effect of the rotational magnification of corrective spectacles on the quantitative evaluation of the VOR *Acta Otolaryngol* 1985;100:81-88

- 25 Miyoshu T, Pfaltz CR Studies on optokinetic habituation. *ORL J Otorhinolaryngol Relat Specialt* 1972;34:308-319
- 26 Böhmer A, Pfaltz CR Vestibular habituation induced by foveolar and retino-peripheral optokinetic training. *ORL J Otorhinolaryngol Relat Specialt* 1978;40 233-246
- 27 Pfaltz CR, Novak B The effect of optokinetic training on vestibular responses. In Hood JD (Ed) *Vestibular mechanisms in health and disease VI Extraordinary meeting of the Barany Society London, Academic Press, 1978, pp. 288-293*
- 28 Valmaggia V, Gottlob I Optokinetic nystagmus elicited by filling-in in adults with central scotoma. *Inv Ophthalmol Vis Sci* 2002;43:1804-1808
- 29 Valmaggia C, Charlier J, Gottlob I Optokinetic nystagmus generation in central scotomas. *Br J Ophthalmol* 2001;85:169-172
- 30 Heide W, Blossfeldt TP, Koenig E, Dichgans J Optokinetic nystagmus, self-motion sensation and their aftereffects in patients with long-lasting peripheral visual field defects. *Clin Vision Sci* 1990;5 133-143
- 31 Simons B, Büttner U The influence of age on optokinetic nystagmus. *Eur Arch Psychiatr Neurol Sci* 1985;234:369-373
- 32 Ben Ezra D, Paez JH Congenital cataract and intraocular lenses. *Am J Ophthalmol* 1983;96:311-314
- 33 Post RB, Rodemer CS, Dichgans J, Leibowitz HW Dynamic orientation responses are independent of refractive error (ARVO abstract) *Invest Ophthalmol Vis Sci Suppl* 1979;18 140-141
- 34 Weder W, Wiegand H Sehschärfestimmung mit Hilfe des optokinetischen Nystagmus Ein neu entwickeltes Gerat auf der Grundlage des Guntherschen Prinzips. *Klin Mbl Augenheilk* 1987;191 149-155
- 35 Das VE, Leigh RJ, Thomas CW, Averbuch-Heller L, Zivotofsky AZ, Discenna AO, Dell'Osso LF Modulation of high-frequency vestibuloocular reflex during visual tracking in humans. *J Neurophysiol* 1995;74 624-632
- 36 Lee MH, Durnford SJ, Crowley JS, Rupert AH Visual vestibular interaction in the dynamic visual acuity test during voluntary head rotation. *Aviat Space Environ Med* 1997;68:111-117
- 37 Jung R Die Registrierung des postrotatorischen und optokinetischen Nystagmus und die optisch-vestibuläre Integration beim Menschen (Vortrag) *Acta Otolaryngol* 1949;36:199-202
- 38 Koenig E, Allum JHJ, Dichgans J Visual-vestibular interaction upon nystagmus slow phase velocity in man. *Acta Otolaryngol* 1978;85:397-410
- 39 Bohmer A, Pfaltz CR On the interaction of vestibular and optokinetic nystagmus in man. *ORL J Otorhinolaryngol Relat Specialt* 1979;41 121-134
- 40 Fujikawa N, Kitahara M Influence of passive and active pendular head rotation on horizontal optokinetic nystagmus. *Acta Otolaryngol Suppl* 1994;510:38-42
- 41 Burr DC, Ross J Contrast sensitivity at high velocities. *Vision Res* 1982;22:479-488
- 42 Carpenter RHS The visual origins of ocular motility. In Cronly-Dillon JR (ed) *Vision and visual function, Vol 8 Eye movements London, MacMillan Press, 1991, pp 1-10*
- 43 Stern RM, Hu S, Anderson RB, Leibowitz HW, Koch KL The effects of fixation and restricted visual field on vection-induced motion sickness. *Aviat Space Environ Med* 1990;61 712-715
- 44 Flanagan MB, May JG, Dobie TG Optokinetic nystagmus, vection, and motion sickness. *Aviat Space Environ Med* 2002;73:1067-1073
- 45 Szlyk JP, Fishman GA, Alexander KR, Revelins BI, Derlacki DJ, Anderson RJ Relationship between difficulty in performing daily activities and clinical measures of visual function in patients with retinitis pigmentosa. *Arch Ophthalmol* 1997;115 53-59
- 46 Turano KA, Geruschat DR, Baker FH, Stahl JW, Shapiro MD Direction of gaze while walking a simple route. Persons with normal vision and persons with retinitis pigmentosa. *Optom Vision Sci* 2001;78 667-675
- 47 Li L, Peli E, Warren WH Heading perception in patients with advanced retinitis pigmentosa. *Optom Vision Sci* 2002;79:581-589
- 48 Huygen PLM, Verhagen WIM, Van Hoof JJM, Horstink MWIM Vestibular hyperreactivity in patients with idiopathic spasmodic torticollis. *J Neurol Neurosurg Psychiatry* 1989;52:782-785
- 49 Verhagen WIM, ter Brugge JP, Huygen PLM Oculomotor, auditory, and vestibular responses in myotonic dystrophy. *Arch Neurol* 1992;49: 954-960
- 50 Verhagen WIM, Huygen PLM, Padberg GW The auditory, vestibular, and oculomotor system in facioscapulohumeral dystrophy. *Acta Otolaryngol Suppl.* 1995;520:140-142
- 51 Fetter M, Hain TC, Zee DS Influence of eye and head position on the vestibulo-ocular reflex. *Exp Brain Res* 1986;64 208-216.

## USH2A MUTATION ANALYSIS IN 70 DUTCH FAMILIES WITH USHER SYNDROME TYPE II

R.J.E. Pennings  
H. te Brinke  
M.D. Weston  
A. Claassen  
D.J. Orten  
H. Weekamp  
A. van Aarem  
P.L.M. Huygen  
A.F. Deutman  
L.H. Hoefsloot  
F.P.M. Cremers  
C.W.R.J. Cremers  
W.J. Kimberling  
H. Kremer





---

## INTRODUCTION

Usher syndrome (OMIM #276900) is an autosomal recessive syndrome that is characterised by sensorineural HI, RP and in some cases vestibular dysfunction. The prevalence of Usher syndrome in Northern Europe is estimated to range from 3.5 to 6.2 per 100,000 inhabitants and the syndrome accounts for about 50% of deaf-blindness cases.<sup>1,2</sup> Three clinical types are distinguished on the basis of audiovestibular features. Usher syndrome type I (USH1) is characterised by congenital, profound deafness, RP and vestibular areflexia. In Usher syndrome type II (USH2) the HI is moderate to severe with downsloping pure-tone audiograms; there is RP and an intact vestibular response. Usher syndrome type III (USH3) is characterised by fast progressive HI, RP and variation in vestibular responses between patients.<sup>3</sup> Initially, it was assumed that USH1 was more prevalent than USH2, however, a large-scale study of Usher syndrome patients from Germany showed that USH2 probably accounts for twice as many cases as USH1.<sup>2</sup>

Several genetic subtypes have been identified for the 3 clinical types of Usher syndrome. To date, eleven loci (USH1A-USH1G, USH2A-USH2C, USH3) are known and the corresponding genes have been identified for seven of these (USH1B/*MYO7A*, USH1C/*USH1C*, USH1D/*CDH23*, USH1F/*PCDH15*, USH1G/*SANS*, USH2A/*USH2A*, USH3A/*USH3A*),<sup>4</sup> and references therein. So far, *USH2A* is the only gene identified for USH2.<sup>5</sup> *USH2A* (OMIM \*276901) encodes usherin, which consists of 1546 amino acids and has an estimated molecular weight of 170-180 kDa.<sup>5,6</sup> At the N-terminal end of the protein there is a signal peptide, which is followed by a thrombospondin domain, a laminin N-terminal domain type VI, 10 laminin-type epidermal growth factor-like domains and 4 fibronectin type III domains.<sup>5,6</sup> Usherin is a basement membrane protein in the mouse and human cochlea and the retina, and is also expressed in many other tissues.<sup>7,8</sup> By in situ hybridisation *USH2A* transcripts were shown to be present only in the perinuclear cytoplasm of the photoreceptor cells in the outer nuclear layer in humans, mice and rats.<sup>9</sup> However, with antibodies against usherin the protein could not be detected in this layer but in the lens capsule and the Bruch's layer between the RPE and the choroid, which is very rich in basement membranes.<sup>7,8</sup> So far, the function of usherin in the cochlea and the retina is unknown.

It is estimated that mutations in *USH2A* account for the majority of USH2 cases.<sup>5</sup> To date, 32 mutations in *USH2A* have been described for Usher syndrome type IIa (USH2a) in a review by Ahmed et al.<sup>4</sup> Different types of mutations are found in the entire coding region of the gene. The most prevalent mutation in *USH2A* is the c.2299delG (p.Glu767fs) mutation. Besides as USH2, mutations in the *USH2A* gene can manifest as atypical Usher syndrome<sup>10</sup> or as nonsyndromic recessive RP.<sup>11,12</sup> Remarkably, two individuals were reported to be homozygous for the c.2276G>T (p.Cys759Phe) mutation without any signs of RP or HI.<sup>12</sup>

This report presents the results of *USH2A* mutation analysis in 70 Dutch families that were clinically classified as USH2. Combining these 70 families with 9 previously reported Dutch families, enables us to estimate the prevalence of *USH2A* mutations as the cause of USH2 in the Netherlands. Also, knowing the causative mutations greatly facilitates DNA-diagnostics and genetic counseling.

## MATERIAL AND METHODS

### *Patients*

Seventy Dutch families with 89 USH2 patients were evaluated in this study. Fifty-six patients were isolated cases and in 14 multicase families there were 33 patients. All patients were diagnosed to have USH2 based on the combination of moderate to severe high-frequency sensorineural HI, RP and intact vestibular responses. All participating family members signed an informed consent form and the study was approved by the local ethics committee. Results of audiometric, ophthalmic and vestibular examinations in a number of the patients have been described previously.<sup>13-17,unpublished results</sup> Affected family members of 21 families did not participate in our clinical studies but were clinically examined elsewhere and referred to our hospital for DNA diagnostics of the *USH2A* gene. Nine of the present 70 families were included in the genetic studies by Weston et al.<sup>6</sup> and by Dreyer et al.<sup>18</sup> So far, only one heterozygous mutation (p.Glu767fs in 6 families and p.Cys419Phe in 3 families) was identified in these families and therefore they were included in the present study in an attempt to identify the second mutation.

---

*Mutation analysis of USH2A*

Genomic DNA was extracted from blood samples according to Miller et al.<sup>19</sup> Oligonucleotide primers used for PCR amplification were previously described by Weston et al.<sup>6</sup> A forward (5'-TGTAACGACGGCCAGT-3') and reverse (5'-CAGGAAACAGCTATGACC-3') M13-tag were added to the described primers. Exons were amplified by PCR, using the PTC200 thermo cycler (MJ Research, Inc.) and standard conditions. The products were purified with the StrataPrep PCR purification Kit (Stratagene). For sequencing, the tags were used as primers. Sequence analysis was performed with the ABI PRISM Big Dye Terminator Cycle Sequencing V2.0 Kit and the reactions were analysed with the ABI PRISM 3700 DNA analyzer (Applied Biosystems). Sequence analysis was performed in one patient per family. In 49 of the 70 families all 21 exons of the *USH2A* gene (GenBank NM 007123, version: 3) were sequenced. In the remaining 21 families heteroduplex analysis, WAVE/DHPLC, Amplification-Refractory Mutation System (ARMS) assay or sequence analysis of a number of exons of the *USH2A* gene were performed as previously described.<sup>6</sup> After the detection of two mutant alleles the remaining exons were not analysed in these 21 families.

The presence of the putative splice site mutation c.949C>A (p.Arg317Arg) was tested in 184 control DNA samples by *AciI* digestion and the prediction of the splice site efficiency was performed by using the splice site prediction program NNSPLICE 0.9 version from the Berkely Drosophila Genome Project website accessible on the World Wide Web ([http://www.fruitfly.org/seq\\_tools/splice.html](http://www.fruitfly.org/seq_tools/splice.html)). An ARMS assay was performed to test for the presence of the nucleotide substitution of a cytosine for an adenine at position 2252 (c.2252C>A), causing p.Ser841Tyr with the following primers, a common forward primer (5'-CAGTGTGACACCTGCAGAGA-3'), a mutant reverse primer (5'-GCAAGGCAGACAGAGGAAGT-3') and a wildtype reverse primer (5'-GCAAGGCAGACAGAGGAAGG-3'). Two mutations introduced a stop codon and were not tested in control samples.

---

## RESULTS

### *USH2A mutation analysis*

In 40 of the 70 USH2 families at least one *USH2A* mutation was identified, one mutation in 27 families and two mutations in 13 families. Ten different mutations were found (Table 1). Six previously described mutations were found in more than one patient, c.1042A>C (p.Asn346His), c.1227G>A (p.Trp409X), c.1256G>T (p.Cys419Phe), c.1606T>C (p.Cys536Arg), c.2137G>C (p.Gly713Arg) and c.2299delG (p.Glu767fs). The p.Glu767fs mutation is the most frequent mutation in the present study and identified in 18 alleles in 16 families. In 13 families the p.Cys419Phe mutation was detected in 14 alleles and we identified 3 families with the p.Trp409X mutation in 3 alleles. The p.Cys536Arg mutation, previously reported in 1 Danish family,<sup>20</sup> was identified in 6 alleles of 6 Dutch families and the p.Asn346His mutation was seen in 3 alleles in 3 families. The latter mutation was previously described in a Danish, American, Swedish and Norwegian family.<sup>6,20</sup> The p.Gly713Arg was identified in 2 alleles and was previously identified in a Danish family.<sup>20</sup> The c.923-924insGCCA (p.His308fs) mutation was identified in one allele of one family. This mutation, referred to as c.921-922insCAGC, was described previously in 2 alleles in 2 American families.<sup>6</sup> Leroy et al.<sup>21</sup> identified in one allele a p.His308fs mutation, which was described as c.921-922insGAGC.

Three novel mutations were identified in this study. In exon 6, the substitution of an adenine for a cytosine at nucleotide position 949 (c.949C>A) is predicted to lead to a new splice site. The donor splice site probability of the sequence increases from 0.13 to 0.85 due to this nucleotide substitution. The nucleotide change does not cause an amino acid substitution (p.Arg317Arg). The mutation was found in four different families; in 3 families heterozygously with an unknown mutation in the second allele and in 1 family in combination with the p.Glu767fs mutation. It was not seen in 184 control samples. Two novel mutations were detected in one patient. Both cause the substitution of a stop codon for a codon for glutamine, p.Gln748X (c.2242C>T) and p.Gln1468X (c.4405C>T) located in exon 13 and in exon 21, respectively (Table 1).

One novel single nucleotide polymorphism (SNP) was detected in 1 patient, the substitution of an adenine for a cytosine at nucleotide position 2252 in exon 13

(c.2252C>A) leads to the amino acid substitution p.Ser841Tyr. This nucleotide change was found in 2 of 93 control samples.

### *USH2a prevalence*

The frequencies of the identified mutations in the Dutch USH2a population are shown in Table 1. The genotype of 9 additional Dutch families from the Nijmegen Usher syndrome studies have been reported previously by Weston et al.<sup>6</sup> and Dreyer et al.<sup>18</sup> In these families both *USH2A* mutations were identified. Of these 9 families, 5 were homozygous for the p.Glu767fs mutation and 1 was homozygous for the p.Trp409X mutation. The three remaining families were compound heterozygous for the p.Cys419Phe and the p.Glu767fs mutation, the p.Cys419Phe and the p.Trp409X mutation and the p.Glu767fs and the p.Trp409X mutation. Including these families to be able to determine the prevalence of USH2a in the Dutch Usher syndrome type II population, results in 79 families with a clinical diagnosis of Usher syndrome type II.

Table 1. Mutations identified in the Dutch USH2a population

Nucleotide change	Amino acid change	Type of mutation	Exon	Domain	Relative frequency (%)
c.923-924 ins GCCA	p.His308fs	Nonsense	6	Laminin type VI domain	0.01 (0.01)
<b>c.949C&gt;A</b>	<b>p.Arg317Arg</b>	<b>Splice-site</b>	<b>6</b>	<b>Laminin type VI domain</b>	<b>0.05 (0.04)</b>
c.1036A>C	p.Asn346His	Missense	6	Laminin type VI domain	0.04 (0.03)
c.1227G>A	p.Trp409X	Nonsense	7	Laminin type VI domain	0.04 (0.07)
c.1256G>T	p.Cys419Phe	Missense	7	Laminin type VI domain	0.18 (0.16)
c.1606T>C	p.Cys536Arg	Missense	9	1st laminin EGF-like domain	0.08 (0.06)
c.2137G>C	p.Gly713Arg	Missense	12	4th laminin like domain	0.03 (0.02)
<b>c.2242C&gt;T</b>	<b>p.Gln748X</b>	<b>Nonsense</b>	<b>13</b>	<b>5th laminin EGF-like domain</b>	<b>0.01 (0.01)</b>
c.2299delG	p.Glu767fs	Nonsense	13	5th laminin EGF-like domain	0.23 (0.31)
<b>c.4405C&gt;T</b>	<b>p.Gln1468X</b>	<b>Nonsense</b>	<b>21</b>	<b>Carboxy tail region</b>	<b>0.01 (0.01)</b>
Unknown					0.35 (0.29)

Newly identified *USH2A* mutations are presented in bold. Patients with one mutated *USH2A* allele were assumed to be of the USH2a subtype. The relative frequency of the mutations is that of *USH2A* alleles in the present study (total number of 80 alleles, including the 9 families with heterozygous mutation previously published<sup>6,18</sup>). \* The relative frequency between brackets includes the genotype of 9 Dutch families previously published in the studies by Weston et al.<sup>6</sup> and Dreyer et al.<sup>18</sup> (total number of 98 alleles).

In 49 of the 79 examined USH2 families (62%), pathogenic mutations in the *USH2A* gene were identified. In 28% (22/79) of the families mutations in both alleles could be detected and in 34% (27/79) a mutation was found in only one allele. In 30 families (38%) no mutations in the *USH2A* gene were discovered. Thus, 45% (71/158) of the mutated alleles in all USH2 families were identified.

When we assume that all the USH2 patients with one mutated *USH2A* allele are true USH2a patients that have a second so far unidentified *USH2A* mutation, it is possible to deduce the estimated prevalence of USH2a in the Dutch USH2 population. When  $a$  is the fraction of detected *USH2A* mutations and  $b$  the fraction of undetected *USH2A* mutations, the fraction of the families with two detected mutations is  $a^2$ , that with one mutation is  $2ab$  and with two undetected mutations is  $b^2$ . Using the ratio between the families with two known mutations and one known mutation together with the two equations  $a^2 + 2ab + b^2 = 1$  and  $a + b = 1$ , one can calculate  $a$  and  $b$  and thus the total number of USH2a families among the studied families. The calculated number of USH2a families was 57 and thus the number of USH2a families in which we did not detect a mutation is 8. This means that the estimated prevalence of USH2a in the studied Dutch USH2 population is 72% (57/79) and that 28% of the mutated USH2 patients is due to mutations in one or more different genes.

#### *Haplotype analysis.*

For the frequently occurring p.Glu767fs mutation it is already known that it represents an ancestral founder mutation.<sup>18</sup> To determine whether this is also true for the most frequent mutations in the present patient group, SNPs in the *USH2A* gene were analysed. In 49 of the 70 families all 21 exons of the *USH2A* gene were sequenced and 10 SNPs could be scored (Table 2). Six of these SNPs were previously described in the study on the haplotypes associated with the p.Glu767fs mutation.<sup>18</sup> In the present study 4 novel SNPs were added. One of these 4 SNPs is located in noncoding sequences (c.1644+34A>C) and 3 are in coding sequences (c.1931A>T, c.3945T>C, c.4371G>A). Although the DNA of the parents of the patients was not available or the *USH2A* gene was not completely sequenced, on the basis of homozygosity we could deduce the haplotype associated with 3 of the frequent mutations, p.Arg317Arg, p.Cys419Phe and p.Cys536Arg (Table 2). The haplotypes associated with the p.Arg317Arg and p.Cys536Arg mutations are the same as that already known to be associated with the p.Glu767fs mutation.<sup>18</sup> The p.Cys419Phe mutation segregates with a different haplotype (derived from 8 families). There were no multiplex families with only one *USH2A* mutation, in which the haplotype of the other affecteds could be evaluated. Analysis of two markers flanking the *USH2A* gene (D1S2827 and D1S490) revealed no mutation-associated alleles.

Table 2 Haplotypes associated with frequently encountered *USH2A* mutations

SNP	nucleotide variation	Exon	p Arg317Arg	p Cys419Phe	p Cys536Arg	p Glu767fs
1	c 373A>G	2	A	G	A	A
2	c 504G>A	3	G	A	G	G
3	c 1419C>T	8	C	C	C	C
4	c 1644+34A>C	9	A	A	A	A
5	c 1931A>T	11	A	T	A	A
6	c 3157+35A>G	15	A	G	A	A
7	c 3812-8G>T	18	T	T	T	T
8	c 3945T>C	18	T	T	T	T
9	c 4371G>A	20	G	G	G	G
10	c 4457A>G	21	A	G	A	A

The p Glu767fs core haplotype was previously described by Dreyer et al <sup>18</sup>

## DISCUSSION

This report describes the results of mutation analysis of the *USH2A* gene in 70 Dutch USH2 families. Ten different mutations were identified, 3 of which are novel (p Arg317Arg, p Gln748X and p Gln1468X). In 62% of these 70 families and in 9 previously published Dutch families, an *USH2A* mutation in at least one allele was identified. Several other studies<sup>6, 20, 21, 22</sup> have performed mutation analysis of the *USH2A* gene and prevalence data are shown in Table 3 for comparison. The percentage of families with an *USH2A* mutation among the selected USH2 families is varying from 42-87%. As can be expected, the present study and the studies by Weston et al <sup>6</sup> and Dreyer et al <sup>20</sup> that used sequence analysis with or without prescreening, report the highest percentages (62%, 67% and 87%, respectively) of families with USH2a. The percentage of detected mutated *USH2A* alleles by Dreyer et al <sup>20</sup> is high, which is mainly due to the high percentage of p Glu767fs alleles.

In the Dutch USH2 population 62% of the USH2 patients were shown to have at least 1 mutation in the *USH2A* gene. In fact, we can estimate that 72% of the USH2 population in fact has USH2a. This percentage is similar to that mentioned in the study by Weston et al <sup>6</sup> (74%) who studied families from various origins. The linkage-based estimation of 90% USH2a among Dutch USH2 families by Pieke-Dahl et al <sup>23</sup> seems to be an overestimate.



In the present study, the p.Glu767fs mutation has a prevalence of 23% of the present *USH2A* alleles, including correction for the previously described Dutch families, this percentage is 31% (Table 3). In other studies, this percentage varies from 32-44% in patients from European countries or the United States.<sup>6,18,21,22</sup> Also the p.Cys419Phe mutation is frequently found, in 16% of the alleles in the Dutch population of *USH2* patients. These results have consequences for DNA-diagnostics. When testing for the p.Glu767fs and the p.Cys419Phe mutations only, already 47% of the mutated alleles can be detected. Also, only 3 of the 10 mutations known in the Dutch population are private mutations. Thus, it is possible to find 68% of the *USH2A* mutations that are detectable by sequencing of the coding region and the exon-intron boundaries, by testing for the mutations that occurred more than once. These mutations are clustered in only 5 exons.

Besides the already known haplotype associated with the p.Glu767fs mutation, we were able to deduce an associated haplotype for the p.Arg317Arg, p.Cys419Phe and the p.Cys536Arg mutations, which suggests an ancestral relationship. The p.Cys536Arg and p.Arg317Arg mutations have the same haplotype as the p.Glu767fs mutation. However, it has to be kept in mind that this haplotype has a relative frequency of 0.60.<sup>18</sup> The p.Cys419Phe mutation is identified in 16 alleles in 15 families (19%) and has another core haplotype. Together with the p.Trp409X and the p.Arg317Arg mutation, which are identified in 6 and 4 families, respectively, the p.Cys419Phe mutation is so far only described in patients from the Netherlands. These mutations might therefore be Dutch founder mutations. However, haplotype analysis of the p.Trp409X mutation was not possible, because in 4 families only a few exons of the *USH2A* gene were sequenced. For statistical significance of the association of these mutations with a specific haplotype more patients have to be analysed and/or DNA of parents or other family members has to become available. The SNP haplotypes were also evaluated in patients with one mutated *USH2A* allele assuming that the deduced haplotypes are indeed always associated with the frequently occurring mutations. This analysis shows that the common haplotype associated with the p.Glu767fs mutation is also frequently associated with the unknown mutation (data not shown). In addition, there are a number of other haplotypes seen in patients with an unknown mutation, three of which occur more than once. Therefore, we can conclude that there are not only one or two frequent, unknown mutations.

Table 3 Prevalence of USH2a in Usher syndrome type II families and prevalence of the p Glu767fs mutation, as presented in several studies

Reference	<i>Eudy et al</i> <sup>5</sup>	<i>Liu et al</i> <sup>10</sup>	<i>Beneyto et al</i> <sup>24</sup>	<i>Leroy et al</i> <sup>21</sup>	<i>Najera et al</i> <sup>22</sup>	Weston et al <sup>6</sup>	Dreyer et al <sup>20</sup>	Dutch population
Used techniques	<i>Sequencing</i>	<i>p Glu767fs screening</i>	<i>p Glu767fs screening</i>	<i>Heteroduplex</i>	<i>SSCP</i>	Sequencing <sup>c</sup>	Sequencing <sup>c</sup>	Sequencing <sup>c</sup>
USH2a <sub>fam</sub> /N <sub>fam</sub>	23/96 (0.24)	12/23 (0.52)	15/59 (0.25)	15/36 (0.42)	23/59 (0.39)	38/57 (0.67)	27/31 (0.87)	<b>49/79 (0.62)</b>
1 allele mut/N <sub>fam</sub>	14/96 (0.15)	8/23 (0.35)	11/59 (0.19)	12/36 (0.34)	15/59 (0.26)	18/57 (0.32)	9/31 (0.29)	<b>27/79 (0.34)</b>
2 alleles mut/N <sub>fam</sub>	9/96 (0.09)	4/23 (0.17)	4/59 (0.06)	3/36 (0.08)	6/59 (0.10)	20/57 (0.35)	18/31 (0.58)	<b>22/79 (0.28)</b>
mut/N <sub>a</sub>	32/192 (0.17)	16/46 (0.35)	19/118 (0.16)	18/72 (0.25)	27/118 (0.23)	58/114 (0.51)	45/62 (0.73)	<b>71/158 (0.45)</b>
p Glu767fs/N <sub>a</sub>	29/192 (0.15)	16/46 (0.35)	19/118 (0.16)	11/72 (0.15)	19/118 (0.16)	31/192 (0.16)	24/62 (0.39)	<b>30/158 (0.19)</b>
p Glu767fs/USH2a <sub>a</sub>	29/46 (0.63)	16/16 (1.00)	19/19 (1.00)	11/30 (0.37)	19/46 (0.41)	31/76 (0.41)	24/54 (0.44)	<b>30/98 (0.31)</b>

Eudy et al<sup>5</sup> evaluated only 18% of the ORF and identified 3 mutations. These studies<sup>10,24</sup> evaluated only the presence of the p Glu767fs mutation. <sup>c</sup> Prescreening with other techniques. In italics, percentages that are related to studies that did not evaluate the entire *USH2A* gene. In bold, the results of the present study and the 9 previously published Dutch USH2a families.<sup>6,18</sup> USH2a<sub>fam</sub>, number of USH2a families, N<sub>fam</sub> number of examined families, N<sub>a</sub> number of examined alleles, USH2a<sub>a</sub>, USH2A alleles.

In three related studies, the audiometric, ophthalmic and vestibular features of 36, 40 and 29 USH2a patients, respectively, were analysed to detect possible genotype-phenotype correlations.<sup>16,17,unpublished results</sup> Extension of the audiometric analysis described in Pennings et al.<sup>16</sup> with 13 USH2a patients also did not reveal significant differences in audiometric performance between groups of patients with truncating or inactivating *USH2A* mutations and groups with non-inactivating *USH2A* mutations. Since the designation non-inactivating for missense mutations cannot be stated definitely until more is known about usherin function and the number of patients per mutation was rather low in the analysis, we cannot exclude that genotype-phenotype correlations might be present for USH2a patients but we expect that the phenotypic differences between groups are minor. So far, only the p.Cys759Phe mutation in the *USH2A* gene was shown to be almost exclusively associated with a specific phenotype namely non-syndromic RP. Only one USH2a patient is described with this mutation and the mutation in the second allele remained undetected.<sup>20</sup> Also, there are two individuals homozygous for the p.Cys759Phe mutation who are non-symptomatic.<sup>12</sup> Not only the p.Cys759Phe mutation exhibits large phenotypic variation but also the p.Glu767fs and the p.Arg334Trp mutations. Patients with the p.Glu767fs mutation can suffer from typical USH2 (homozygous and heterozygous), atypical USH with progressive hearing loss and variable vestibular dysfunction and RP (homozygous or heterozygous), RP with mild hearing loss or RP only (heterozygous).<sup>10,11</sup> The p.Arg334Trp mutation when homozygously present either causes USH2 or atypical USH.<sup>25</sup> These phenotypic differences together with interfamilial and intrafamilial differences in USH2 suggest that both genetic and environmental factors influence the phenotypic consequences of *USH2A* mutations.

## REFERENCES

- 1 Rosenberg T, Haim M, Hauch A-M, Parving A The prevalence of Usher syndrome and other retinal dystrophy hearing impairment associations Clin Genet 1997,51 314-321
- 2 Spandau UHM, Rorhschneider K Prevalence and geographical distribution of Usher syndrome in Germany Graefe's Arch Clin Exp Ophthalmol 2002,240 495-498
- 3 Kimberling WJ, Möller C Clinical and molecular genetics of Usher syndrome J Am Acad Audiol 1995,6 63-72
- 4 Ahmed ZM, Riazuddin S, Riazuddin S, Wilcox ER The molecular genetics of Usher syndrome Clin Genet 2003,63 431-444
- 5 Eudy JD, Weston MD, Yao SF, Hoover DM, Rehm HL, Ma-Edmonds M, Ahmad I, Cheng JJ, Ayuso C, Cremers C, Davenport S, Moller C, Talmadge CB, Beisel KW, Tamayo M, Morton CC, Swaroop A,

- Kimberling WJ, Sumegi J. Mutation of a gene encoding a protein with extracellular matrix motifs in Usher syndrome type IIa. *Science* 1998;280:1753-1757.
- 6 Weston MD, Eudy JD, Fujita S, Yao S-F, Usami S, Cremers C, Greenburg J, Ramesar R, Martini A, Moller C, Smuth RJ, Sumegi J, Kimberling WJ. Genomic structure and identification of novel mutations in usherin, the gene responsible for Usher syndrome type IIa. *Am J Hum Genet* 2000;66:1199-1210.
- 7 Bhattacharya G, Miller C, Kimberling WJ, Jablonski MM, Cosgrove D. Localization and expression of usherin: a novel basement membrane protein defective in people with Usher's syndrome type IIa. *Hear Res* 2002;163:1-11.
- 8 Pearsall N, Bhattacharya G, Wisecarver J, Adams J, Cosgrove D, Kimberling WJ. 2002. Usherin expression is highly conserved in mouse and human tissues. *Hear Res* 174:55-63.
- 9 Huang D, Eudy JD, Uzvolgyi E, Davis JR, Talmadge CB, Pretto D, Weston MD, Lehman JE, Zhou M, Seemayer TA, Ahmad I, Kimberling WJ, Sumegi J. Identification of the mouse and rat orthologs of the gene mutated in Usher syndrome type IIa and the cellular source of *USH2A* mRNA in retina, a target tissue of the disease. *Genomics* 2002;80:195-203.
- 10 Liu XZ, Hope C, Liang CY, Zou JM, Xu LR, Cole T, Mueller RF, Bunday S, Nance W, Steel KP, Brown SD. A mutation (2314delG) in the Usher syndrome type IIA gene: high prevalence and phenotypic variation. *Am J Hum Genet* 1999;64:1221-1225.
- 11 Rivolta C, Sweklo EA, Berson EL, Dryja TP. Missense mutation in the *USH2A* gene: association with recessive RP without hearing loss. *Am J Hum Genet* 2000;66:1976-1978.
- 12 Bernal S, Ayuso C, Antñolo G, Gimenez A, Borrego S, Trujillo MJ, Marcos I, Calaf M, Del Rio E, Baiget M. Mutations in *USH2A* in Spanish patients with autosomal recessive RP: high prevalence and phenotypic variation. *J Med Genet* 2003;40:e8 (<http://www.jmedgenet.com/cgi/content/full/40/1/e8>).
- 13 van Aarem A, Wagenaar M, Pinckers AJLG, Huygen PLM, Bleeker-Wagemakers AM, Kimberling BJ, Cremers CWRJ. Ophthalmologic findings in Usher syndrome type 2A. *Ophthalmic Genetics* 1995;16:151-158.
- 14 van Aarem A, Pinckers AJLG, Kimberling WJ, Huygen PLM, Bleeker-Wagemakers EM, Cremers CWRJ. Stable and progressive hearing loss in type 2A Usher's syndrome. *Ann Otol Rhinol Laryngol* 1996;105:962-967.
- 15 Wagenaar M, van Aarem A, Huygen P, Pieke-Dahl S, Kimberling W, Cremers C. Hearing impairment related to age in Usher syndrome types 1B and 2A. *Arch Otolaryngol Head Neck Surg* 1999;125:441-445.
- 16 Pennings RJE, Huygen PLM, Weston MD, van Aarem A, Wagenaar M, Kimberling WJ, Cremers CWRJ. Pure tone hearing thresholds and speech recognition scores in Dutch patients carrying mutations in the *USH2A* gene. *Otol Neurotol* 2003;24:58-63.
- 17 Pennings RJE, Huygen PLM, Orten DJ, Wagenaar M, van Aarem A, Kremer H, Kimberling WJ, Cremers CWRJ, Deutman AF. Evaluation of visual impairment in Usher syndrome 1b and Usher syndrome IIa. *Acta Ophthalmol Scand* 2004 in press.
- 18 Dreyer B, Tranebjærg L, Brox V, Rosenberg T, Möller C, Beneyto M, Weston MD, Kimberling WJ, Cremers CWRJ, Liu XZ, Nilssen Ø. A common ancestral origin of the frequent and widespread 2299delG *USH2A* mutation. *Am J Hum Genet* 2001;69:228-234.
- 19 Miller SA, Dykes DD, Polesky HF. A simple salting out procedure for extracting DNA from human nucleated cells. *Nucleic Acids Res* 1988;16:1215.
- 20 Dreyer B, Tranebjærg L, Rosenberg T, Weston MD, Kimberling WJ, Nilssen Ø. Identification of novel *USH2A* mutations: implications for the structure of *USH2A* protein. *Eur J Hum Genet* 2000;8:500-506.
- 21 Leroy BP, Aragon-Martin JA, Weston MD, Bessant DAR, Willis C, Webster AR, Bird AC, Kimberling WJ, Payne AM, Bhattacharya SS. Spectrum of mutations in *USH2A* in British patients with Usher syndrome type II. *Exp Eye Res* 2001;72:503-509.
- 22 Najera C, Beneyto M, Blanca J, Aller E, Fontcuberta A, Millan JM, Ayuso C. Mutations in myosin VIIa (*MYO7A*) and usherin (*USH2A*) in Spanish patients with Usher syndrome types I and II, respectively. *Hum Mutat* 2002;20:76-77.
- 23 Pieke-Dahl S, van Aarem A, Dobin A, Cremers CWRJ, Kimberling WJ. Genetic heterogeneity of Usher syndrome type II in a Dutch population. *J Med Genet* 1996;33:753-757.
- 24 Beneyto MM, Cuevas JM, Millan JM, Espinos C, Mateu E, Gonzalez-Cabo P, Baiget M, Domenech M, Bernal S, Ayuso C, Garcia-Sandoval B, Trujillo MJ, Borrego S, Antñolo G, Carballo M, Najera C. Prevalence of 2314delG mutation in Spanish patients with Usher syndrome type II (*USH2*). *Ophthalmic Genet* 2000;21:123-128.
- 25 Adato A, Weston MD, Berry A, Kimberling WJ, Bonne-Tamir A. Three novel mutations and twelve polymorphisms identified in the *USH2A* gene in Israeli *USH2* families. *Hum Mutat* 2000;15:388.



## USHER SYNDROME TYPE III CAN MIMIC OTHER TYPES OF USHER SYNDROME

R.J.E. Pennings  
R.R. Fields  
P.L.M. Huygen  
A.F. Deutman  
W.J. Kimberling  
C.W.R.J. Cremers



## INTRODUCTION

The Usher syndromes, named after Charles Usher, a British ophthalmologist from the beginning of the previous century, comprise a number of related autosomal recessive hereditary diseases that affect hearing, vision and in some cases, vestibular function. HI is congenital and of sensorineural origin. Vision is impaired by pigmentary retinopathy or retinitis pigmentosa (RP) and is characterised by childhood or adolescent onset and severe constriction of visual fields that ultimately leads to tunnel vision.

Clinically, the Usher syndromes are classified into three different types.<sup>1</sup> Usher syndrome type I is characterised by congenital, profound sensorineural HI with abnormal speech development, vestibular areflexia and RP. Usher syndrome type II shows moderate to severe congenital high-frequency HI, intact vestibular responses and RP. Usher syndrome type III involves postlingual, progressive sensorineural HI, variable vestibular responses and RP.<sup>2</sup> These three clinical types of Usher syndrome are genetically heterogeneous and currently eleven loci (USH1A-USH1G, USH2A-USH2C, USH3) and six genes (USH1b-MYO7A, USH1c-USH1C, USH1d-CDH23, USH1f-PCDH15, USH2a-USH2A, USH3-USH3) have been identified.<sup>3</sup>

Owing to the observation of a high prevalence of progressive HI in the Finnish population of Usher syndrome patients, research into Usher syndrome type III has mainly been conducted in Finland. It resulted in several clinical<sup>2,4-7</sup> and genetic<sup>8-11</sup> reports on Usher syndrome type III. Recently, the *USH3* gene has been identified with three pathogenic mutations.<sup>8</sup> Later, the genomic structure of the *USH3* gene was revised and new mutations were identified.<sup>12, 13</sup> In view of these findings, we have recently performed linkage and mutation analyses on the *USH3* gene of several families with Usher syndrome. These analyses identified the first Usher syndrome type III family from the Netherlands with a new *USH3* mutation. Phenotype and genotype characteristics of the two patients in this family are described below.



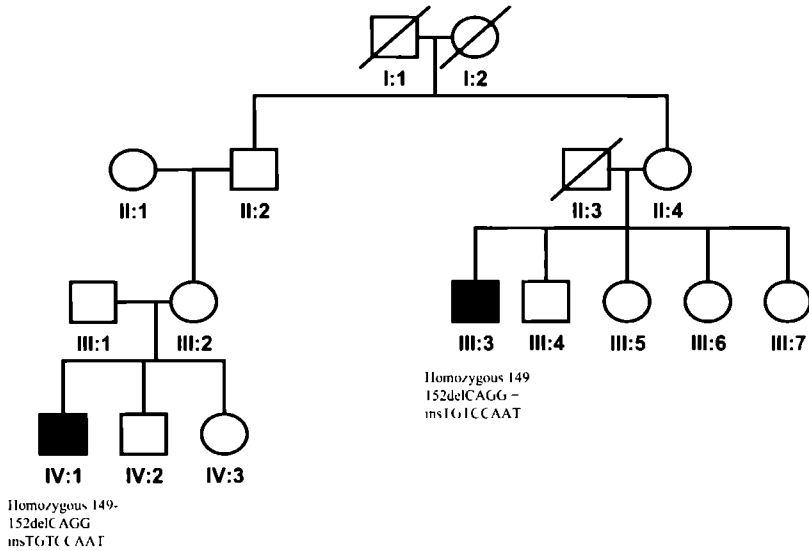

Figure 1. Pedigree of a Dutch family with a homozygous 149-152delCAGG + insTGCCAAT mutation in *USH3*. Squares indicate men, circles indicate women. Filled symbols indicate affected individuals. Dashed symbols indicate deceased individuals.

## PATIENTS AND METHODS

Nearly a decade ago, two Usher syndrome patients from a Dutch family (family 1525) agreed to participate in the Nijmegen Usher syndrome studies. In 2002, Patient IV:1 was a young woman aged 21 years, who was first seen at our outpatient clinic at age < 3 years. Patient III:3 was a man aged 44 years, who was first seen at the age of 23 years. Blood samples were taken from these patients and their relatives and sent to the Center for the Study and Treatment of Usher syndrome in Omaha (Nebraska, USA) for linkage and mutation analyses. On the basis of the clinical findings described below, it was first decided to test the affected persons' blood samples for mutations in the *MYO7A* gene responsible for USH1B. As no disease-causing mutations were identified in *MYO7A*, it was decided to test the *USH3* gene for pathogenic mutations as well.

After informed consent had been obtained, the two patients underwent clinical examination according to our study protocol. This consisted of medical history

and audiovestibular and ophthalmological examinations. Audiometric examination included standard pure-tone audiometry in a sound-treated room. Individual longitudinal pure-tone threshold data were analysed for progression of HI using linear regression analysis (threshold on age); out-of-scale thresholds and thresholds that could be attributed to vibro-tactile stimulation were excluded. Progression was considered to be significant when a significantly positive slope ( $P < 0.025$ ) was detected for the threshold data at a sufficiently high number of different sound frequencies ( $P < 0.05$  in the appropriate binomial distribution).

Vestibular testing consisted of electronystagmography using a rotatory chair with computer analysis and caloric tests, as described previously.<sup>14</sup> Saccadic, optokinetic and vestibular nystagmus responses were evaluated. The cervico-ocular reflex was tested in the case of lack of a vestibular response.<sup>15</sup>

Ophthalmological examination included corrected visual acuity measurements, slit-lamp microscopy and ophthalmoscopy. The fundus of patient III:3 was photographed. Goldmann perimetry, using test targets V-4, III-4, I-4, I-3, I-2 and I-1, was performed to evaluate visual fields. Visual fields were compared to the patterns of progressive visual field impairment described by Grover et al.<sup>16</sup> Electro-oculographic and electroretinographic examinations were performed as described previously.<sup>17, 18</sup>

## RESULTS

### *Genetics*

The two patients were initially diagnosed as having Usher syndrome type I on the basis of severe hearing loss and the inadequate speech of individual IV:1 and the vestibular areflexia of individual III:3. Recently, mutation analysis of the *USH3* gene has been performed and revealed a homozygous deletion of four bases (CAGG) coupled with the insertion of 8 bases (TGTC CAAT) at position 149, leading to a frameshift in codon 50 with the creation of a stop at codon 61 in both patients (using the revised gene structure<sup>12,13</sup>). This mutation is expected to totally disrupt the production of the USH3 protein. The distribution of mutations within this family is shown in Figure 1. Despite the homozygous mutations, consanguinity does not apply to this family.

*Audiometry*

In individual IV:1, HI was first noticed at the age of 8 months. The first pure-tone audiogram, obtained at the age of 3 years, showed a mean threshold of 105 dB HL at 1, 2 and 4 kHz. At present, she is suffering from severe to profound HI and has the typical "speech of the deaf". Patient III:3 has remarkably well-developed speech for his profound HI. His mother stated that his hearing started to deteriorate from the age of 4-5 years onwards. Therefore, we conclude that this individual had no (or only limited) prelingual HI. However, no threshold evaluations were available relating to prelingual age. Longitudinal analysis of pure-tone thresholds showed severe to profound hearing loss in both affected individuals. No significant progression in HI could be detected in patient IV:1 over a follow-up period of 11 years (age 3 - 14 years) or in patient III:3 over a follow-up period of 14 years (age 23 - 37 years) (Figure 2). Figure 3 shows the mean pure tone audiograms of the two patients.

*Vestibulo-ocular responses*

Individual III:3 started walking at 13 months, which strongly suggests intact vestibular function at that age. However, examination at the age of 37 years revealed vestibular areflexia with typical cervico-ocular reflex enhancement.<sup>15</sup> There are no indications of a history of infectious disease or treatment with ototoxic drugs. Individual IV:1 started walking at the age of 14 months and had normal vestibular responses when examined at 13 years. Saccades and optokinetic nystagmus responses were normal in both patients and neither of them showed spontaneous or gaze-evoked nystagmus.

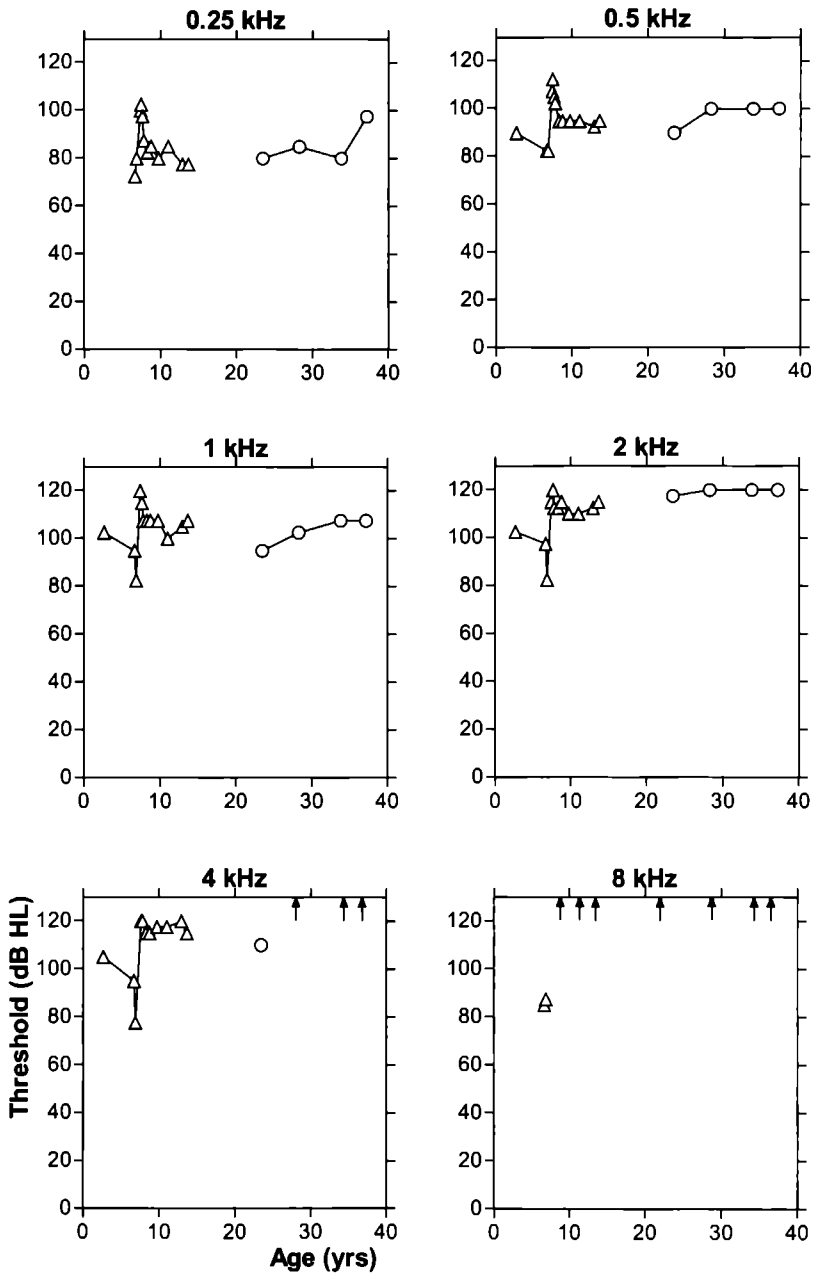
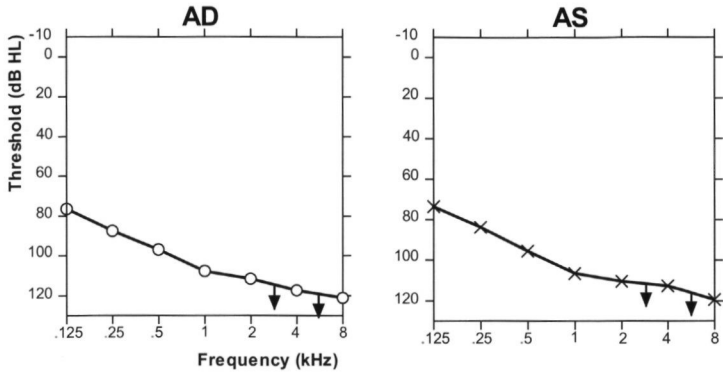

Figure 2 Longitudinal analysis of binaural mean air conduction thresholds (dB HL) in Usher syndrome type III patients IV 1 ( $\Delta$ ) and III 3 (O) related to age (yrs) Arrows indicate excluded out-of-scale thresholds

**IV:1**



**III:3**

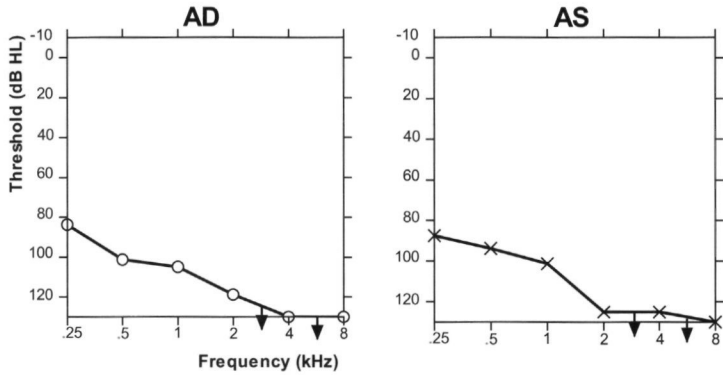
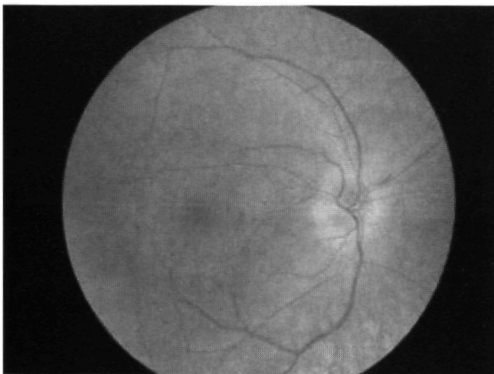

Figure 3. Mean pure-tone audiograms of patients IV:1 (mean age 8.6 years) and III:3 (mean age 30.7 years). Attached arrows indicate higher-than-depicted threshold because of excluded out-of-scale values

**FIGURE 4a**



**FIGURE 4b**

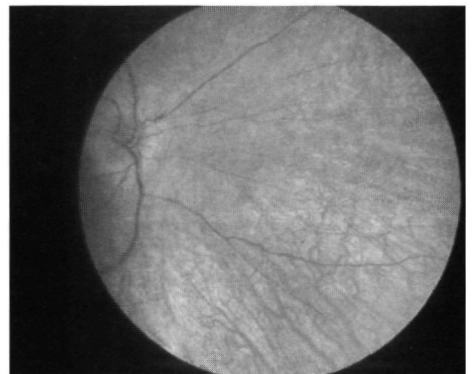

Figure 4. Funduscopy images of the right eye of patient III:3 showing retinitis pigmentosa sine pigmento. Figure 4.a depicts the centre and figure 4.b the nasal periphery of the right eye

Table 1. Ophthalmological examination results of patients IV:1 and III:3

	IV:1	III:3
Age (yrs)	14	33
Corrected visual acuity	OD 0.5 ; OS 0.4	OD: 0.5 , OS: 0.6
Media	ODS normal	ODS normal
Goldmann perimetry	Field phenotype 2	Field phenotype 4
EOG (Arden ratio)	OD: 0.93 OS: 0.76	OD: 0.98 OS: 1.12
ERG	ODS extinguished	ODS extinguished
Dark adaptation	Not performed	Subnormal
Funduscopy	retinitis punctata albescens	retinitis pigmentosa sine pigmento

OD oculo dextra, right eye; OS: oculo sinistra, left eye; ODS: both eyes

### *Ophthalmological examinations*

Table 1 lists the ophthalmological examination results for individual IV:1 at the age of 14 years and for individual III:3 at the age of 33 years. The best-corrected visual acuity measured in patient IV:1 (OD:0.5; OS:0.4) was slightly poorer than that in patient III:3 (OD:0.5; OS:0.6). Both patients had a clear lens without any signs of cataract formation. Funduscopy in individual IV:1 showed RP with symmetrical, sparse bone spicules in all quadrants and small yellowish-white spots in the retinal pigment epithelium: retinitis punctata albescens (RPA). Funduscopy of patient III:3 revealed RP without any bone spicules: retinitis pigmentosa sine pigmento (RPSP) as can be seen in Figure 4. Goldmann perimetry confirmed constriction of the visual fields, which was more severe in individual III:3 than in individual IV:1. At the age of 37 years, patient III:3 showed a small temporal island in the left eye for the isopter at test target V-4. At the age of 13 years, individual IV:1 showed nasal restriction and a temporal ring scotoma for the isopter at test target III-4. Neither patient was able to see test target I-1. Therefore, patient IV:1 was judged to have field phenotype 2 while individual III:3 was judged to have field phenotype 4, as defined by Grover et al.<sup>16</sup> The EOG Arden ratio (Lp/Dt ratio) was < 1.80, which indicates functional impairment of the retinal pigment epithelium. Both patients had an extinguished ERG that also confirmed RP.

## DISCUSSION

### *Genetics*

Although Usher syndrome type III is believed to be rare (2-4% of all Usher patients), it constitutes a general proportion of 40% of all Usher patients in Finland.<sup>5</sup> Recently, Joensuu et al.<sup>8</sup> have identified the *USH3* gene and three causative mutations. Y100X (Fin<sub>major</sub>) is a nonsense mutation identified as the Finnish founder mutation in 52 Finnish families. M44K (Fin<sub>minor</sub>), a substitution of lysine for methionine, was encountered in two Finnish families. The c.231-233delATT, a 3 bp deletion resulting in the substitution of one methionine for isoleucine and leucine at codons 77 and 78, was identified in a consanguineous Italian family previously linked to *USH3*.<sup>19</sup> Fields et al. recently described the revised genomic structure of the *USH3* gene and four new disease-causing mutations.<sup>12</sup> Adato et al.<sup>13</sup> described similar findings with an *USH3A* transcript of 232 amino acids, however, they predicted this protein (designated clarin-1) to have four transmembrane domains instead of the three domains suggested by Fields et al.<sup>12</sup> Adato et al. also suggested that *USH3A* possibly plays a role in sensory synapses and is expressed in mouse sensory hair cells.<sup>13</sup> The present Dutch family has an additional mutation in *USH3* that was homozygously present in both subjects: 149-152delCAGG + insTGTCCAAT.

### *Audiometry*

Usher syndrome type III is generally characterised by progression of sensorineural HI. However, no progression could be detected in either of the present two patients over a follow-up of over 10 years. In the Finnish patients, progression was found to be severe, although there was wide variation in progression and onset age between patients.<sup>24</sup> Pakarinen et al.<sup>2</sup> reported on 42 Usher syndrome patients, linked to the *USH3* locus. From their Tables 1-2, listing the first and last pure-tone threshold (at 0.5-4 kHz), we calculated individual progression in thresholds of 0-4 dB/year. In their Fig. 2, these authors showed serial audiograms of 3 patients. In two cases (Figs 2b and 2c), average progression was 2-4 dB/year at all frequencies. In one case (Fig. 2a) average progression was 1-6 dB/year at 0.125-1 kHz and 8-13 dB/year at 2-8 kHz. Comparing the present data to those reported by Pakarinen et al.<sup>2</sup>, it would seem that our patient IV:1 had profound HI at a relatively young age. This patient may have had severe or profound congenital HI or have experienced early, severe progression. In either case, HI prohibited normal speech and

language development. Remarkably, Pakarinen et al.<sup>2</sup> (1995, p. 147) reported that "Speech expression was either normal or slightly deviant, but in almost all cases good enough for communication." Consequently, Usher type III may be clinically misdiagnosed as Usher type I when there is early, severe HI to the degree shown by individual IV:1. On the other hand, Usher syndrome type III may resemble Usher type II when the onset of progression is relatively late and the rate of progression is not clearly different from that reported in USH2A patients.<sup>20</sup> All the Finnish Usher type III patients were selected on the basis of clinical findings. However, the present two Dutch cases demonstrate that the phenotype related to mutations in the *USH3* gene may be atypical for Usher type III and can mimic those of other clinical types of Usher syndrome.

#### *Vestibular function*

Although vestibular function is often said to be variable in Usher syndrome type III, there is hardly any evidence of this. The first instrumental evaluation was performed on four affected members of one family.<sup>6</sup> Caloric responses were present in three out of the four patients. The fourth patient had spontaneous nystagmus compatible with periodic alternating nystagmus. Therefore it can be questioned whether meaningful evaluation of vestibular responses was actually feasible in this patient. Pakarinen et al. performed vestibular examination on 17 patients linked to the *USH3* locus. The results were normal in 9 subjects, whereas 8 patients showed "decreased" function. One of these patients apparently had vestibular areflexia.<sup>2</sup> Gasparini et al.<sup>19</sup> mentioned that vestibular function was normal in their four Italian Usher type III patients, without giving any details of methods and findings. The available evidence suggests that although vestibular function may be decreased, complete vestibular areflexia is certainly not typical of Usher type III. This does not exclude the possibility of incidental findings of vestibular areflexia due to an intercurrent cause, such as infectious disease or treatment with ototoxic drugs. Otterstedde et al. has recently introduced a new clinical subtype of Usher syndrome type I that consists of profoundly deaf patients with normal vestibular function.<sup>21</sup> However, their data were only based on clinical findings and no attention was paid to the underlying genotype. In view of the present findings in individual IV:1, we believe that profoundly hearing impaired individuals with normal vestibular responses should be tested for *USH3* mutations.



*Ophthalmological findings*

Progression of visual deterioration in Usher syndrome type III occurs before the age of 40 years and is continuous up to that age.<sup>7</sup> Visual fields are generally still normal at a mean age of 16 years, but they contain a ring scotoma at a mean age of 22 years that breaks at a mean age of 27 years. Around the age of 30 years, tunnel vision will have developed, while at the age of 37 years, visual acuity will have dropped to below 0.05 (severely impaired).<sup>7</sup> The present patient III:3 had tunnel vision without any peripheral islands at the age of 34 years, which is in line with previous findings. Remarkably, patient IV:1 had a breaking ring scotoma for test target V-4 at the age of 14 years, which seems relatively young.

The present two patients showed remarkable fundoscopic features: IV:1 had RPA, whereas III:3 had RPSP. RPA and RPSP are both manifestations of RP. These findings probably do not specifically relate to the USH3 genotype; fundus findings of the Finnish patients were typical of pigmentary retinopathy.<sup>2</sup> Remarkably, we could only find two previous reports connecting RPA to HI. Van Aarem et al.<sup>22</sup> described RPA in a 45-year-old USH2A patient [H17] who has recently turned out to have a C419F mutation in the *USH2A* gene, whereas the remaining mutation on the other allele remains to be identified. Her sister [H16] is also affected and has the same mutation, but she does not have RPA. Botelho et al.<sup>23</sup> described the combination of RPA and congenital HI in two siblings aged 7 and 11 years. Usher syndrome was considered, but there was no clinical diagnosis and the genotype was undetermined. To our knowledge, there are no references in Medline on the combination of RPSP and HI.

## CONCLUSION

The genotype and phenotype of two Dutch Usher syndrome patients showed that individual IV:1 had profound sensorineural HI already at prelingual age, normal vestibular responses and RPA, while individual III:3 had profound sensorineural HI with remarkably well-developed speech, RPSP and vestibular areflexia. These findings suggest that Usher syndrome type III might be misdiagnosed as either Usher type I or II. This study also showed that fundoscopic forms of pigmentary retinopathy (RPA and RPSP) can occur in Usher's syndrome.

## REFERENCES

- 1 Davenport SLH, Omenn GS. The heterogeneity of Usher syndrome In Littlefield JW, Ebbing FJG, Henderson JW (eds). Fifth International Conference on Birth Defects Amsterdam Excerpta Medica 1977;87-88 (abstract)
- 2 Pakarinen L, Sankila E-M, Tuppurainen K, Karjalainen S, Kaariainen H Usher syndrome type III (USH3): the clinical manifestations in 42 patients Scand J Logoped Phoniatr 1995;20:141-150
- 3 Van Camp G, Smith RJH. Hereditary Hearing Loss Homepage (HHH) Available from URL:<http://www.dnalab-www.uia.ac.be/dnalab/hhh/>. Accessed July 2002
- 4 Karjalainen S, Pakarinen L, Teräsvirta M, Kääriäinen H, Vartiainen E Progressive hearing loss in Usher's syndrome Ann Otol Rhinol 1989;98:863-866.
- 5 Pakarinen L, Karjalainen S, Simola KOJ, Laippala P, Kaitalo H. Usher's syndrome type 3 in Finland Laryngoscope 1995;105 613-617
- 6 Karjalainen S, Teräsvirta M, Karja J, Kaariäinen H Usher's syndrome type III ENG findings in four affected and six unaffected siblings J Laryngol Otol 1985;99 43-48
- 7 Pakarinen L, Tuppurainen K, Laippala P, Mäntytarva M, Puhakka H The ophthalmological course of Usher syndrome type III. Int Ophthalmol 1996;19:307-311
- 8 Joensuu T, Hämäläinen R, Yuan B, Johnson C, Tegelberg S, Gasparini P, Zelante L, Pirvola U, Pakarinen L, Lehesjoki A-E, de la Chapelle A, Sankila E-M. Mutations in a novel gene with transmembrane domains underlie Usher syndrome type 3 Am J Hum Genet 2001, 69 673-684.
- 9 Joensuu T, Blanco G, Pakarinen L, Sistonen P, Kääriäinen H, Brown S, de la Chapelle A, Sankila E-M Refined mapping of the Usher syndrome type III locus on chromosome 3, exclusion of candidate genes, and identification of the putative mouse homologous region. Genomics 1996;38 255-263
- 10 Joensuu T, Hämäläinen R, Lehesjoki A-E, de la Chapelle A, Sankila E-M A sequence-ready map of the Usher syndrome type III critical region on chromosome 3q. Genomics 2000;63:409-416
- 11 Sankila E-M, Pakarinen L, Kaariäinen H, Aittomäki K, Karjalainen S, Sistonen P, de la Chapelle A Assignment of an Usher syndrome type III (USH3) gene to chromosome 3q. Hum Mol Genet 1995;4 93-98.
- 12 Fields RR, Zhou G, Huang D, Davis JR, Möller C, Jacobson SG, Kimberling WJ, Sumegi J Usher syndrome type III: Revised genomic structure of the *USH3* gene and identification of novel mutations Am J Hum Genet 2002;71 607-617.
- 13 Adato A, Vreugde S, Joensuu T, Avidan N, Hamalainen R, Belenkiy O, Olender T, Bonne-Tamir B, Ben-Asher E, Espinos C, Millán JM, Lehesjoki A-E, Flannery JG, Avraham KB, Pietrokovski S, Sankila E-M, Beckmann JS, Lancet D *USH3A* transcripts encode clarin-1, a four-transmembrane-domain protein with a possible role in sensory synapsis. Eur J Hum Genet 2002;10 339-350
- 14 Marres HAM, van Ewijk M, Huygen PLM, Kunst HPM, Van Camp G, Coucke P, Cremers CWRJ. Inherited nonsyndromic hearing loss An audiovestibular study in a large family with autosomal dominant progressive hearing loss related to DFNA2 Arch Otolaryngol Head Neck Surg 1997;123:573-577
- 15 Huygen PLM, Verhagen WIM, Nicolassen MGM. Cervico-ocular reflex enhancement in labyrinthine-defective and normal subjects Exp Brain Res 1991;87:457-464.
- 16 Grover S, Fishman GA, Anderson RJ, Alexander KR, Derlacki DJ. Rate of visual field loss in pigmentary retinopathy Ophthalmology 1997;104:460-465
- 17 Thijssen JM, Pinckers AJLG, Otto AJ. A multipurpose optical system for ophthalmic diagnosis. Ophthalmologica 1974;168:308-314.
- 18 Pinckers AJLG, Hardus P, Nabbe B. The EOG in unilateral eye disease. Injuries. Graefé's Arch Clin Exp Ophthalmol. 1983;220:87-91
- 19 Gasparini P, De Fazio A, Croce AI, Stanziale P, Zelante L Usher syndrome type III (USH3) linked to chromosome 3q in an Italian family J Med Genet 1998;35:666-667.
- 20 Pennings RJE, Huygen PLM, Weston MD, van Aarem A, Wagenaar M, Kimberling WJ, Cremers CWRJ. Pure tone hearing thresholds and speech recognition scores in Dutch patients carrying mutations in the *USH2A* gene. Otol Neurotol 2003;24:58-63.
- 21 Otterstedde CR, Spandau U, Blankenagel A, Kimberling WJ, Reisser C. A new clinical classification for Usher's syndrome based on a new subtype of Usher's syndrome type I. Laryngoscope 2001;111 84-86
- 22 Van Aarem A, Wagenaar M, Pinckers AJLG, Huygen PLM, Bleeker-Wagemakers EM, Kimberling WJ, Cremers CWRJ Ophthalmologic findings in Usher syndrome type 2A Ophthal Genet 1995;16 151-158
- 23 Botelho PJ, Blinder KJ, Shahinfar S Familial occurrence of retnuts punctata albescens and congenital sensorineural deafness. Am J Ophthalmol 1999;128:246-247.



# CHAPTER 4

## WOLFRAM SYNDROME



# 4.1

---

## SEX-RELATED HEARING IMPAIRMENT IN WOLFRAM SYNDROME PATIENTS IDENTIFIED BY INACTIVATING *WFS1* MUTATIONS.

R.J.E. Pennings  
P.L.M. Huygen  
J.M.W. van den Ouweland  
K. Cryns  
L.D. Dikkeschei  
G. Van Camp  
C.W.R.J. Cremers



---

## INTRODUCTION

Wolfram syndrome is an autosomal recessively inherited syndrome that was first described by Wolfram and Wagener in 1938.<sup>1</sup> It is a progressive neurodegenerative syndrome that is characterised by the features diabetes insipidus, diabetes mellitus, optic atrophy and deafness (DIDMOAD). Wolfram syndrome is rare with an estimated general prevalence of 1:770,000 and a carrier frequency of 1:354.<sup>2</sup> Minimal diagnostic criteria are juvenile-onset diabetes mellitus and optic atrophy both mainly manifesting in the first decade of life. Sixty-two percent of the patients develop central (hypothalamic) diabetes insipidus (in 73%) and “deafness” (hearing impairment) in the second decade of life. Renal tract abnormalities (58%) present in the third decade, followed by neurological complications (62%), such as cerebellar ataxia and/or myoclonus in the fourth decade. Other complications include gastro-intestinal dysmotility (24%) and primary gonadal atrophy. Psychiatric disorders, such as depression, psychosis or organic brain syndrome, as well as impulsive and physical aggression are also common (60%) in these patients.<sup>2</sup> Behavioural abnormalities are usually related to widespread neuropathological changes in the brain of Wolfram syndrome patients.<sup>3</sup> These patients have a median age at death of 30 years, which usually results from central respiratory failure with brainstem atrophy, infectious disease, or suicide.<sup>2</sup>

Genetic studies have identified *WFS1*, located on chromosome 4p16.3 as the gene involved in Wolfram syndrome.<sup>4,5</sup> *WFS1* codes for wolframin, a transmembrane protein that consists of 890 amino acids. Although its role and exact function in the cell still have to be unravelled, wolframin shows predominant subcellular localization in the endoplasmic reticulum.<sup>6</sup>

Recently, mutations in *WFS1* have been found not only to be responsible for the autosomal recessive Wolfram syndrome, but also for an autosomal dominant form of non-syndromic sensorineural HI designated DFNA6/14.<sup>7,8</sup> Wolfram syndrome is characterised by high-frequency sensorineural HI, in contrast to DFNA6/14 which is characterised by low-frequency sensorineural HI.<sup>9,10</sup> HI in DFNA6/14 can be either progressive or non-progressive.<sup>10</sup> Mutation analysis of *WFS1* in families with DFNA6/14 revealed that the identified pathogenic mutations in this disorder all are small non-inactivating (missense) mutations, whereas most of the pathogenic mutations in Wolfram syndrome patients are inactivating mutations.<sup>11</sup>



A recent review by Cryns et al. demonstrated that currently 80 different *WFS1* mutations have been identified in Wolfram syndrome and DFNA6/14. These authors propose that homozygous or compound heterozygous missense mutation carriers show a relatively mild Wolfram syndrome phenotype, when compared to carriers of two inactivating *WFS1* mutations.<sup>12</sup>

Two major reviews on HI in Wolfram syndrome were based on clinically diagnosed Wolfram syndrome.<sup>9,13</sup> It was decided to examine hearing ability in Wolfram syndrome patients with identified *WFS1* mutations.<sup>14</sup> A study of a large consanguineous family with four Wolfram syndrome patients, showed a significantly increased risk of hearing loss and diabetes mellitus, independently, in heterozygous carriers of *WFS1* mutations.<sup>15</sup> Another report described a consanguineous family with two patients with a homozygous R629W mutation in *WFS1* and one sib who is heterozygous for this mutation.<sup>16</sup> The heterozygous carrier has congenital sensorineural HI, of which the authors doubt whether it is associated with the *WFS1* mutation. It was decided not only to examine the patients with Wolfram syndrome, but also their family members with the purpose to include audiometric findings in related heterozygous carriers of *WFS1* mutations in the present report. The relatives were screened for low-frequency sensorineural HI, as has been described for DFNA6/14 in many publications.<sup>10,17-19</sup> This report summarises the results of these examinations in seven families with Wolfram syndrome, identified by *WFS1* mutations.

## PATIENTS AND METHODS

### *Subjects*

In this study, 33 members of seven families (WF1-WF6 and WF10) with Wolfram syndrome were examined, including 11 affected and 22 unaffected individuals. Figure 1 shows the pedigrees of these families and the individuals examined. Eleven patients from seven families were diagnosed to have Wolfram syndrome on the basis of clinical findings (at least diabetes mellitus and optic atrophy) and the identification of at least one mutation in *WFS1*. After written informed consent had been obtained, medical history was taken in all 33 examined individuals and focused on features of Wolfram syndrome.

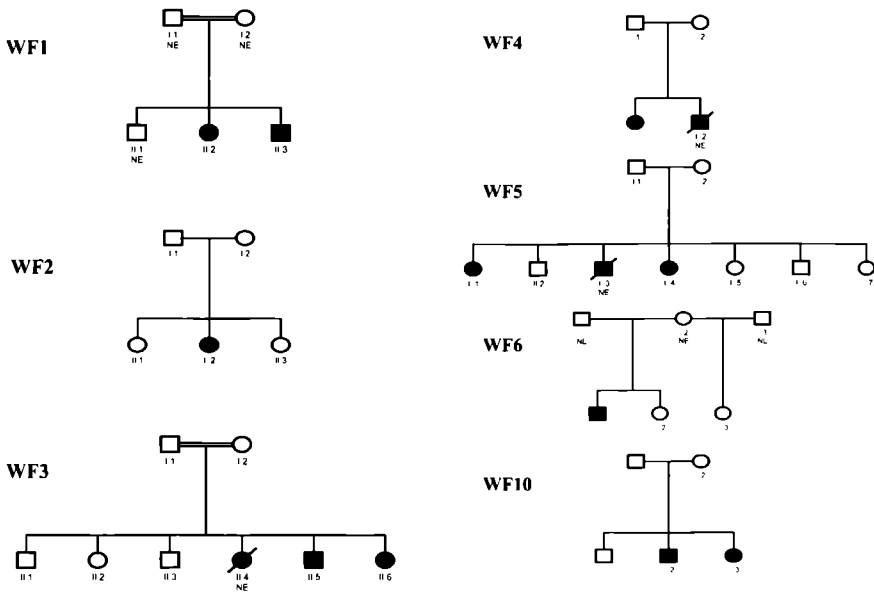

Figure 1 Pedigrees of seven families with Wolfram syndrome (WF1-WF6, WF10). squares, male; circles, female; filled symbols indicate affected individuals; dashed symbols indicate deceased individuals; NE, not evaluated.

Genetic details on mutation analyses of the families WF1-WF6 have been described elsewhere.<sup>14</sup> Mutation analysis of the unaffected relatives identified 17 carriers of heterozygous mutations in *WFS1* and 4 non-carriers. In 6 of the 7 families both disease-causing mutations in *WFS1* were identified, whereas only one mutated allele was found in family WF2, however, intronic and regulatory regions were not examined in this family; mutations in these regions cannot be excluded and neither can mutations in a gene other than *WFS1*. Two families (WF1 and WF3) reported consanguinity and mutation analysis identified homozygous mutations in *WFS1* (WF1: 460+1G>A, WF3: Y508-L512del). In family WF2 only one mutation in *WFS1* was identified: Y528fsX542. Two compound heterozygous mutations in *WFS1* were identified for individual II:1 from family WF4: Y508-L512del and V412fsX440. In family WF5 two missense mutations were identified in *WFS1*: D211N and P607R. These two missense mutations do not result in inactivation of the *WFS1* gene, which is the case in the identified mutations in all other families. In family WF6 the homozygous V509fsX517 mutation was identified in patient II:1. In family WF10, compound heterozygous mutations in *WFS1* (Q667X and V142fsX251) were identified, which are known to be pathogenic in other families previously described.<sup>20,21</sup>

### *Audiovestibular evaluation*

All 33 examined individuals underwent otoscopy and standard audiometric examination consisting of pure tone audiometry according to International Standards Organization (ISO) standards, which included air and bone conduction thresholds for the octave frequencies 0.25 – 8 kHz. Bone conduction levels were evaluated to exclude conductive hearing loss. When HI was detected, speech audiometry was performed by presenting a standard monosyllabic Dutch word list at either ear and analyzed as previously described.<sup>21</sup> Two patients from family WF3 (II:5 and II:6) underwent Brainstem Evoked Response Audiometry (BERA) following normal standards and six patients (WF3, II:5 and II:6; WF6, II:1; WF2, II:2; WF10, II:2 and II:3) underwent vestibular examination with a rotatory chair and electronystagmography as previously described.<sup>23</sup>

### *Statistical analyses*

Last-visit pure tone threshold data (binaural mean air conduction threshold) were used for cross-sectional linear regression analysis (threshold on age). Progression at a given sound frequency was designated significant when a significant positive slope ( $P < 0.025$ , Student's *t* test) was found. Significant progression of HI was concluded to exist if significant positive slopes were found in a significantly high relative frequency of the measured sound frequencies ( $P < 0.05$ ) according to the appropriate binomial distribution.

Linear regression analysis of longitudinal individual threshold-on-age data (binaural air conduction level) was applied to analyse individual progression of HI (Figure 4). The slope was called annual threshold deterioration (ATD) and expressed in dB/year.

Analysis of covariance (ANCOVA) was performed to compare between slopes and intercepts of the regression lines pertaining to individual threshold measurements as per frequency. Where a pooled regression line could not be derived following this procedure, a trend line was visually fitted (Figure 4). The "fit" of the trend line was performed using two criteria: (1), about equal numbers of patients, whether followed up or measured only once, had to have thresholds better or worse than predicted by this line; (2), about equal numbers of the patients followed had to show progression higher or lower than indicated by the

trend line. It should be noted that the Y intercept was varied in steps of 10 dB. The parameters of the trend lines (slope and Y intercept) were used for constructing ARTA, depicted in Figure 5. For each patient concerned, it was checked whether the thresholds predicted for a given age conforming to the ARTA data fitted well to the observed threshold data (Figure 2, marginal ages indicated).

Student's t test was used to compare mean pure tone thresholds at a given frequency between relevant pairs of subgroups (e.g. males vs. females); this test included Welch's correction if Bartlett's test detected unequal variances. The level of significance used was  $P = 0.05$  (Figure 3A). The same test was used to check whether or not any significant difference in threshold could be explained by a difference in age between the subgroups involved (Figure 3B).

Cross-sectional binaural mean speech recognition scores were plotted against age and binaural mean  $PTA_{1,2,4 \text{ kHz}}$  level. Nonlinear regression analysis was used to fit nonlinear dose-response curves with variable slope as previously reported.<sup>22</sup> The 90% Correct score ( $X_{90}$ ) was designated onset age for  $X = \text{age}$  and onset level for  $X = PTA_{1,2,4 \text{ kHz}}$  (pure tone average at 1, 2 and 4 kHz). The slope was called deterioration rate in the performance-age plot and deterioration gradient in the performance-impairment plot. To simplify the results, "local average" slope (i.e. on a linear scale) for  $X > X_{90}$  was obtained by fitting a straight line as previously reported, using a nonlinear method to estimate  $X_{90}$  with 95% confidence intervals (95% CI) (Figure 6).<sup>24</sup>

## RESULTS

The onset age and clinical features of the Wolfram syndrome patients are shown in Table 1 and some of these have been described previously.<sup>14,25</sup> Figure 2 shows the audiometric data (single and serial observations) obtained for all patients with Wolfram syndrome and their non-affected heterozygous relatives (carriers) with one *WFS1* mutation, arranged by family. Only one of the heterozygous carriers of *WFS1* mutations (WF3, 1:2) showed HI; since long she suffered from chronic suppurative otitis media and had developed bilateral maximal conductive hearing losses (Figure 2). Occlusion of the ear canals by the earmolds of conventional ear conduction hearing aids caused persisting otorrhoea, therefore a bone-anchored hearing aid (BAHA) was applied with success. None of the other examined

individuals showed an air-bone gap and all other carriers had normal hearing for their age. A remarkable difference between the degree of HI in male and female sibs was noticed within the families WF1, WF3 and WF10. Patients II:1 and II:4 from family WF5 had normal hearing for their age and two non-inactivating missense mutations in *WFS1* and therefore were excluded from the analysis. They only had mild features of Wolfram syndrome and developed diabetes mellitus at young age, but optic atrophy not before age 26-28 years. (Table 1) So far, they showed no additional features of Wolfram syndrome.

The results of the cross-sectional analysis were analysed following the exclusion of the male patients, as well as the two female patients (WF5, II:1 and II:4) with normal hearing. No significant progression of HI at increasing age was found (data not shown). The possibility cannot be excluded that the lack of significance related to the small number ( $n=5$ ) of the cases. The pooled ATD was 3.8 dB/year.

Student's *t* test comparing the mean binaural threshold data for the female group ( $n=5$ ) and the male group ( $n=4$ ) of Wolfram syndrome patients demonstrated significantly more HI, predominantly in the mid-frequency range, in the female patients with Wolfram syndrome (Figure 3A).

This difference is unlikely to have been caused by a difference in age between the two evaluated patient groups (Figure 3B). Longitudinal and single snapshot threshold data of all female patients are depicted in Figure 4. In Table 2 the serial data of the longitudinal analysis in six patients are described. Five of these patients were found to have significant progression of HI, whereas this was not the case in individual II:2 from family WF1, who probably experienced progression of HI before the first measurement (Table 2, Figure 2). The dashed trend lines in Figure 4 visualise the ATD (dB/year) per frequency for all patients. The Y intercept and the slope of the trend line (Figure 4) were used to construct the ARTA, which showed remarkable progression of mid- and high-frequency HI leading to severe to profound HI within the first decades of life (Figure 5). The dotted lines in Figure 2 indicate the predicted threshold for female Wolfram syndrome patients (based on the ARTA of Figure 5) at the specified age. The slopes of the trend lines for the low frequencies (0.25 and 0.5 kHz) were in the range of 1.5-2.0 dB HL/year, whereas the slopes for mid- and high-frequencies were in the range of 4.0-4.5 dB HL/year.

Table 1 Clinical findings and onset age in 11 patients with Wolfram syndrome

Family patient	Age (y)	Sex	Cons	Onset Age				Renal tract abnormalities (onset age)	Neurologic abnormalities (onset age)	Additional complications (onset age)
				DM	OA	D	DI			
<u>WF1</u>										
II 2	28	F	yes	3	22	7	18	yes (7)	none	Paranoid depression
II 3	22	M	yes	3	11	13	19	no	Seizures	Depression
<u>WF2</u>										
II 2	20	F	no	5	6	11	11	yes (11)	Cerebellar atrophy, bilateral extensor plantar responses	none
<u>WF3</u>										
II 5	32	M	yes	1	10	9	6	yes (20)	Anosmia	Pulmonal stenosis (18), Primary gonadal atrophy
II 6	30	F	yes	4	13	12	NA	yes (13)	none	None
<u>WF4</u>										
II 1	35	F	no	4	8	9	45	no	Peripheral neuropathy *	Irritable bowel syndrome
<u>WF5</u>										
II 1	47	F	no	10	28	45	NA	no	none	none
II 4	42	F	no	12	26	NA	NA	no	none	Hypothyroidism, Hypertension
<u>WF6</u>										
II 1	28	M	no	4	12	25	11	yes (17)	none	Scoliosis, Primary gonadal atrophy
<u>WF10</u>										
II 2	25	M	no	2	8	24	8	no	Peripheral neuropathy *, Anosmia (8), Dysphagia (21)	Primary gonadal atrophy
II 3	23	F	no	8	9	10	16	no	none	Depression (16)

cons, consanguinity, D, deafness, DI, diabetes insipidus, DM, diabetes mellitus, F, female, M, male, OA, optic atrophy, NA, not applicable, y, years, +, secondary to diabetes mellitus (Table is modified from Van den Ouweland et al , 2002)<sup>14</sup>

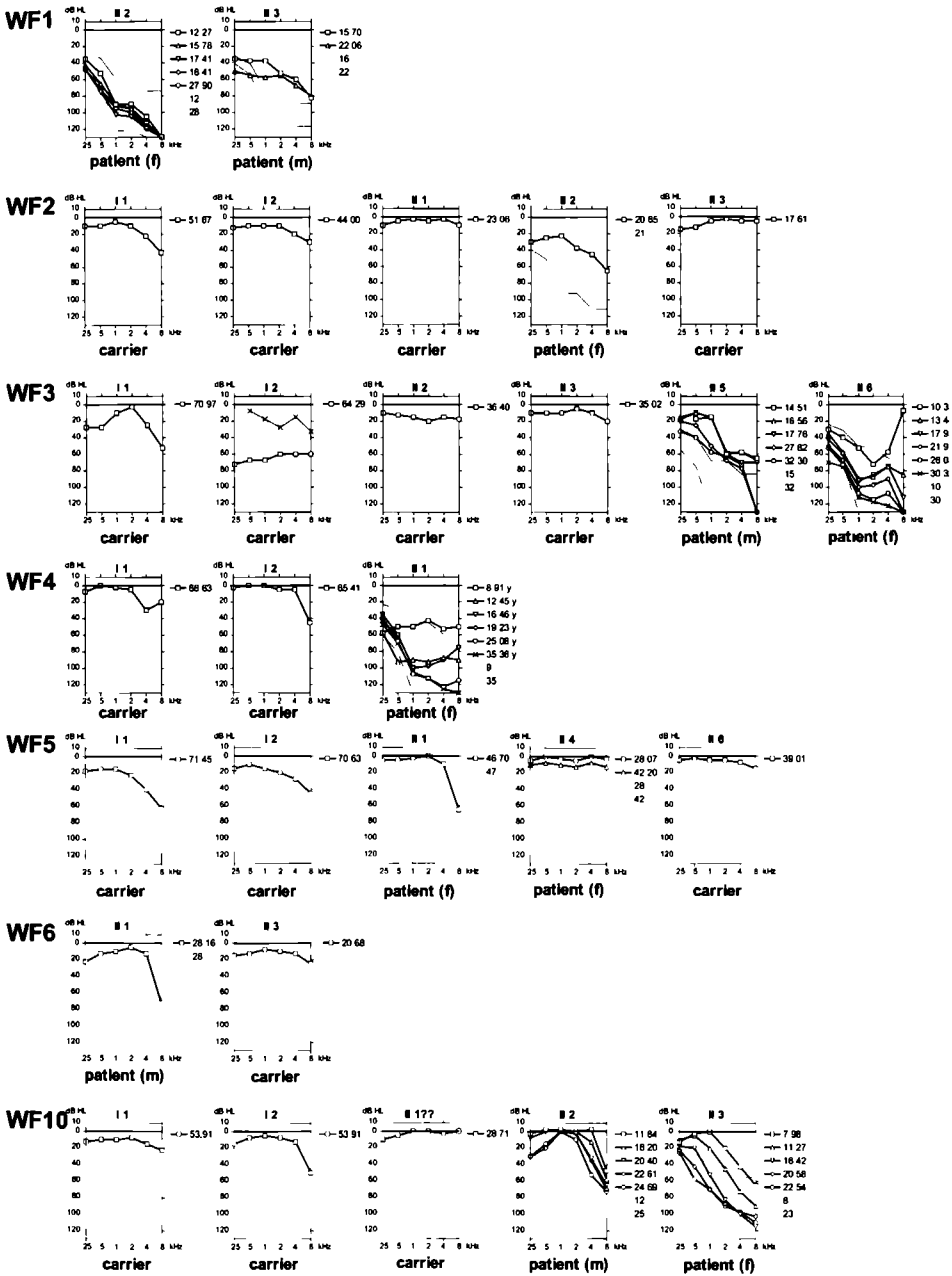

Figure 2 Individual, in some cases serial, (binaural mean) pure-tone audiograms from affected (patient) males (m) and females (f) and non-affected *WFS1* mutation-carrying individuals (carrier). A selection of serial audiograms was made if necessary for clarity. Dotted lines indicate estimated pure-tone thresholds at the age(s) of examination as indicated, relating to women with Wolfram syndrome and inactivating *WFS1* mutations. Crosses in individual I:2 from family WF3 indicate binaural mean bone conduction thresholds. Age (in years) of examinations are depicted at the right of the audiograms.

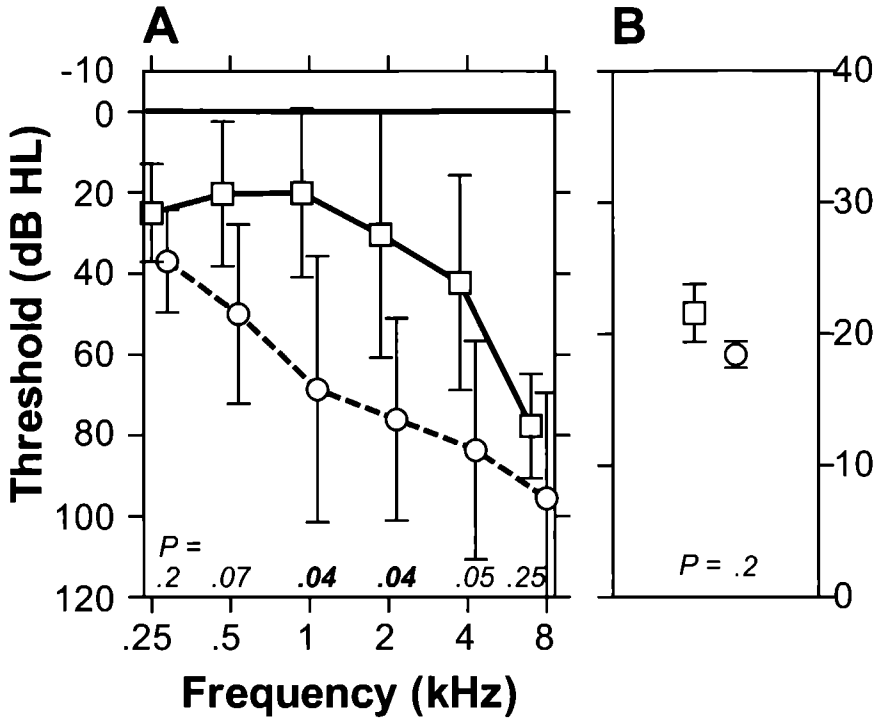

Figure 3 Comparison of binaural mean pure-tone thresholds per frequency (A) between four male patients (squares) and five female patients (circles, patients II 1 and II 4 from WF5 excluded) with Wolfram syndrome P values are depicted in italics and bold figures indicate significance Comparison of age between both groups is also depicted (B)



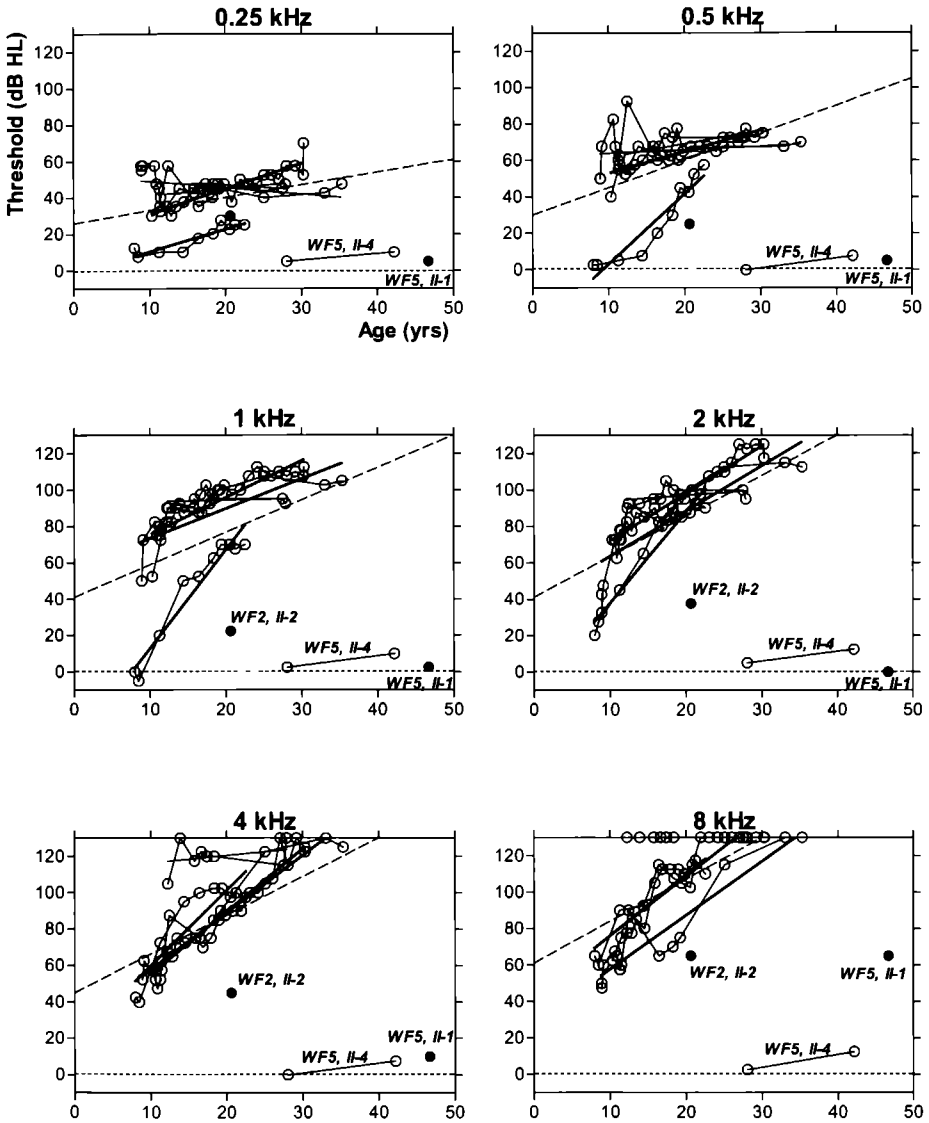

Figure 4. Longitudinal analyses of binaural mean air conduction threshold (dB HL) for separate frequencies in four female patients (WF1, II:2; WF3, II:6; WF4, II:1; WF10, II:3). Individual regression lines are included; bold lines mark significant progression. Snapshots (filled circle) of two female patients (WF2, II:2; WF5, II:1) and two serial observations of one female patient (WF5, II:4) are also included. Individuals II:1 and II:4 from family WF5 are shown and excluded from analysis and trend evaluation because of normal hearing. Dashed line indicates trend line for each specific

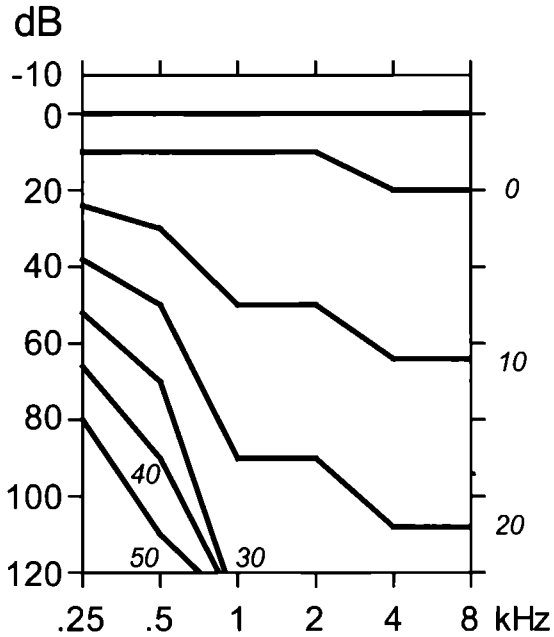

Figure 5 ARTA for female Wolfram syndrome patients  
Age (year) in italics

Table 2 Annual Threshold Deterioration (in dB HL/year) by frequency in six patients with Wolfram syndrome

Patient	0.25 kHz	0.5 kHz	1 kHz	2 kHz	4 kHz	8 kHz
WF1, II 2	0.4	0.8	0.1	0.3	0.4	-
WF3, II 5	0.6	1.5	3.0	1.0	1.1	4.5
WF3, II 6	1.4	1.2	2.0	2.6	3.5	3.3
WF4, II 1	-0.4	0.2	1.6	2.5	3.1	3.0
WF10, II 2	2.1	1.6	0.2	3.8	4.0	1.8
WF10, II 3	1.2	3.9	5.4	5.0	4.1	3.3

Bold figures indicate significant progression, male patients in italics

Speech recognition scores are depicted in Fig 6. After exclusion because of outlying values of individuals II:1 and II:4 from family WF5 in the performance versus age plot there was significant deterioration in speech recognition score with increasing age (Figure 6A). The speech recognition score also deteriorated significantly with increasing PTA<sub>1,2,4 kHz</sub> (Figure 6B). The onset age was 21 year (95% CI: 19-24 year) and the onset level was 78 dB HL (95% CI: 64-96 dB HL). The

deterioration rate (Figure 6A) was 4.0 % per year (95% CI: 2.6-5.3 %/year) and the deterioration gradient (Figure 6B) was 1.4 % per dB HL (95% CI: 0.2-2.9 %/dB HL).

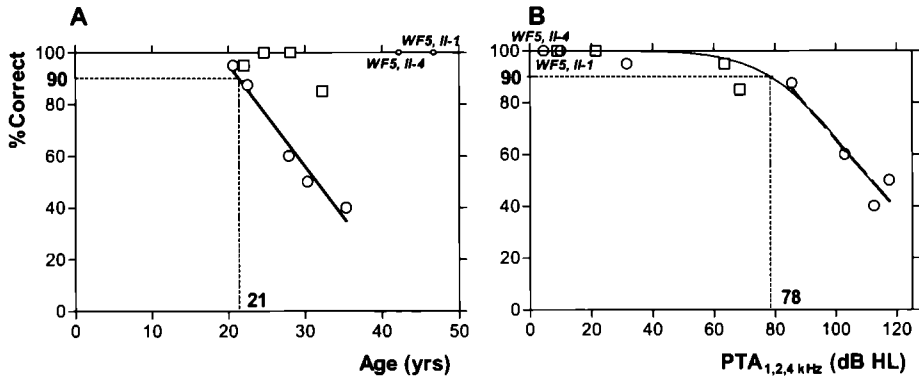

Figure 6 Cross-sectional analysis of speech recognition score relative to (A) age (year) and (B) PTA<sub>1,2,4</sub> kHz (dB HL) in 11 Wolfram syndrome patients. Regression lines apply to female patients only. Scores for the individuals II 1 and II 4 from family WF5 are shown as well, they were fully normal and therefore represent outlying values (small symbols) in the performance-age plot (A). The scores for the male patients (squares) demonstrate almost non-impaired speech recognition

Vestibular function was evaluated in six patients. In all but one patient (WF10, II:3) optokinetic nystagmus responses could not be elicited because of substantial visual impairment. Four of the six individuals had normal vestibulo-ocular function. One individual had a hyperactive vestibulo-ocular reflex with asymmetry. One individual (WF6, II:1) had vestibular areflexia and an enhanced cervico-ocular reflex. BERA was performed in both patients from family WF3 and showed no evidence of retrocochlear pathology.

## DISCUSSION

The present audiovestibular study of families with Wolfram syndrome is the first one based on the identification of mutations in the *WFS1* gene. This study examined 11 patients with Wolfram syndrome from seven families. Patients generally showed progressive mid- and high-frequency sensorineural HI. Two patients (WF5; II:1 and II:4) showed exceptionally well preserved hearing for their

age. Their data are presented but were excluded from the analyses on the basis of their genotype (more details below). Within the families WF1, WF3 and WF10 a remarkable difference in HI between the male and female sibs was noticed (Figure 2). Further comparison of the degree of HI between male (n=4) and female (n=5) patients with Wolfram syndrome caused by inactivating *WFS1* mutations revealed that the female patients showed significantly more HI than the male patients especially in the mid-frequency range (Figure 3). Analyses of speech recognition scores of the female patients (n=5) revealed early onset at a relatively high level of HI; recognition scores deteriorated fairly rapidly with advancing age and an onset level of 78 dB HL (Figure 6). BERA, performed in two patients, showed no evidence of retrocochlear pathology, similar to previously reported findings.<sup>13</sup>

Two patients from family WF5 with virtually normal hearing were excluded from the analyses because they had remarkably mild symptoms and signs of Wolfram syndrome, anyway, at a relatively high age (43 and 48 years) associated with two missense mutations in *WFS1* (D211N and P607R). They were the only patients having two missense mutations in our patient group; all other identified *WFS1* mutations lead to the inactivation of the entire gene. Probably, the combination of two missense mutations or these two specific mutations in *WFS1* result in full-length wolframin formation with poor functionality that leads to a milder phenotype of the Wolfram syndrome, as was already suggested by Cryns et al.<sup>12</sup> Young et al.<sup>8</sup> reported that a homozygote from a DFNA6/14 family had type I diabetes mellitus at age 3 years. There was no evidence of optic atrophy at age 25 years. This individual also had mild sensorineural HI of 20-30 dB HL at 500 and 4000 Hz. When his symptoms are compared to the observations in individuals II:1 and II:4 from the present family WF5, it can be suggested that he might develop optic atrophy in the next five to ten years.

In this study, 17 heterozygous carriers of *WFS1* mutations were examined for HI similar to that found for DFNA6/14. None of the mutation-carrying relatives showed low-frequency sensorineural HI (Figure 2). A previous study<sup>15</sup> showed that heterozygous carriers of *WFS1* mutations from one large consanguineous family had a significantly increased risk of HI, however, these data were not confirmed in our study of the present Wolfram syndrome families. Low-frequency sensorineural HI in DFNA6/14 is mainly caused by small non-inactivating missense mutations particularly located in the intracellular domains of wolframin.<sup>11</sup> To date, only two missense mutations (K193Q and K634T) have been

described to cause DFNA6/14 and not to be located in the C-terminal domain of the transcript.<sup>11,26</sup> The presently identified D211N missense mutation in family WF5 is, like K193Q, located in the N-terminal domain of the protein, however, it is not associated with low-frequency HI in the heterozygous carrier I:1 of this family. Further genetic research is needed to explain the differences between Wolfram syndrome and DFNA6/14 and the function of wolframin.

An intriguing finding in the present study was that among the patients with inactivating *WFS1* mutations the affected women showed significantly more HI than the affected men (Figure 3). This was also evident from sibwise comparisons in families WF1, WF3 and WF10 (Figure 2). The predicted thresholds (based on the examination results of 5 female patients) relative to age are shown as dotted lines for all Wolfram syndrome patients in Figure 2. All 4 male patients showed better hearing relative to their age than would be predicted if they were female patients (Figure 2, dotted lines applying to indicated ages). The two excluded female patients (WF5, II:1 and II:4) showed normal hearing for their age, much better than predicted. Only female patient WF2, II:2 had better hearing than would be expected for her age. On the basis of our examinations we suggest that her hearing might deteriorate progressively in the next coming years. In a separate evaluation of the literature (data and references not shown; n=20 families, 26 male and 24 female patients) no substantial difference in onset age of diabetes mellitus, diabetes insipidus, optic atrophy as well as deafness between male and female sibs from one family could be found.

We speculate that the apparent sex-related difference in HI between female and male Wolfram syndrome patients in the present study might be explained by the involvement of sex hormones. Several studies have shown that estrogen is important for inner ear homeostasis. In Turner syndrome patients (X0), a progressive dip in the mid- frequencies in combination with early-onset age-related high-frequency sensorineural HI is detected. Progression has been documented in 61% of the Turner syndrome patients aged over 35 years, whereas a quarter of them requires hearing aids.<sup>27</sup> These patients do not produce estrogen and have ovarian dysfunction. Another study has shown that estrogen not only has a nuclear regulating function but also acutely inhibits ion transport by isolated stria vascularis. Estrogen decreases the secretion of K<sup>+</sup> by the inhibition of potassium channels through a nongenomic action mechanism that leads to inhibition of ion transport.<sup>28</sup> Several studies already emphasised the importance of

nongenomic actions of estrogen in the body. It is believed to play a role in neuroprotection of the brain,<sup>29</sup> the release of insulin from the pancreatic Langerhans islets,<sup>30</sup> and may also be involved in psychiatric diseases like Alzheimer's disease and schizophrenia.<sup>31</sup> These findings are in support of a hypothesis that nongenomic actions of estrogen are involved in the pathophysiology of Wolfram syndrome. We believe that wolframin plays a crucial role in the rapid intracellular responses of estrogen. Nongenomic actions of estrogen result in an intracellular  $\text{Ca}^{2+}$  increase, that mediates several intracellular messenger actions. A  $\text{Ca}^{2+}$  activated ATPase pump is located in the membrane of the endoplasmic reticulum and seems to be involved in this process as well. Possibly, the nongenomic effect of estrogen on this pump results from an interaction with the wolframin transmembrane protein that is also located in the membrane of the endoplasmic reticulum. However, the exact role of wolframin in the target organs and inner ear has to be unravelled before any such hypothesis can be confirmed or rejected.

The performance-age plot of the analysed speech recognition scores showed that Wolfram syndrome has an early onset deterioration (21 years) and a fairly high deterioration rate (4.0 %/year, Figure 6A). The described deterioration rate is comparable to that reported for presbycusis, although presbycusis is characterised by later onset at about age 75 years.<sup>32</sup> The performance-impairment plot (Figure 6B) shows that Wolfram syndrome patients have remarkably well preserved speech recognition for the degree of HI, as long as they have not yet developed profound deafness. The onset level (95% score) in Wolfram syndrome patients was 78 dB HL, whereas previously reported onset levels were 46 dB HL for DFNA9 and 65 dB HL for DFNA2 patients. Although speech recognition started to deteriorate in Wolfram syndrome patients at a substantially higher level of HI than in DFNA9, the deterioration gradient in Wolfram syndrome showed more similarity to DFNA9 rather than DFNA2 (Wolfram, 1.4%/dB; DFNA9, 1.2 %/dB; DFNA2, 0.5 %/dB).<sup>32</sup>

To date only a few studies have examined vestibular function in Wolfram syndrome patients.<sup>9,13</sup> Although Wolfram syndrome is a progressive neurodegenerative disorder that also includes polyneuropathy, only limited data are available regarding the involvement of the vestibulocochlear nerve. The present study adds data on six patients who underwent electronystagmography. In one patient vestibular areflexia was detected. Previous case reports (n=8) have

described findings of vestibular hyporeflexia.<sup>9,13</sup> Vestibular areflexia, however, has not been reported previously and may be an atypical finding in patient II:1 from family WF6. In another 8 patients normal vestibular function has been described previously.<sup>9,13</sup> These findings seem comparable to the present study and therefore we conclude that there is no firm evidence of vestibular dysfunction in Wolfram syndrome patients.

The present audiovestibular study of families with Wolfram syndrome is the first study based on mutation analysis of *WFS1*. It concludes that in patients with inactivating mutations progression of HI mainly occurred in the mid- and high-frequency range. Female patients with Wolfram syndrome showed substantially more HI than male patients, including their sibs with the same mutation and genetic background. We speculate that this difference can be explained by the involvement of wolframin in nongenomic actions of estrogen resulting in intracellular Ca<sup>2+</sup> increase and thus influencing inner ear homeostasis. Speech recognition scores showed a similar degree of age-related deterioration as in presbycusis, however with a much earlier onset of HI. The type of deterioration of speech recognition in Wolfram syndrome patients showed some characteristics with the types found in DFNA2 and DFNA9 patients.

## REFERENCES

- 1 Wolfram DJ, Wagener H Diabetes mellitus and simple optic atrophy among siblings report of four cases Proc Mayo Clin 1938,13 715-718
- 2 Barrett TG, Bundey SE, Macleod AF Neurodegeneration and diabetes UK nationwide study of Wolfram (DIDMOAD) syndrome Lancet 1995,346 1458-1463
- 3 Gregorios JB Wolfram's syndrome with schizophrenia and central hypoventilation a neuropathological study J Neuropathol Exp Neurol 1989,48 308
- 4 Inoue H, Tanizawa Y, Wasson J, Behn P, Kalidas K, Bernal-Mizrachi E, Mueckler M, Marshall H, Donis-Keller H, Crock P, Rogers D, Mikuni M, Kumashiro H, Higashi K, Sobue G, Oka Y, Permutt MA A gene encoding a transmembrane protein is mutated in patients with diabetes mellitus and optic atrophy (Wolfram syndrome) Nat Genet 1998,20 143-148
- 5 Strom TM, Hortnagel K, Hofmann S, Gekeler F, Scharfe C, Rabl W, Gerbitz KD, Meitinger T Diabetes insipidus, diabetes mellitus, optic atrophy and deafness (DIDMOAD) caused by mutations in a novel gene (wolframin) coding for a predicted transmembrane protein Hum Mol Genet 1998,7 2021-2028
- 6 Takeda K, Inoue H, Tanizawa Y, Matsuzaki Y, Oba J, Watanabe Y, Shinoda K, Oka Y *WFS1* (Wolfram syndrome 1) gene product predominant subcellular localization to endoplasmic reticulum in cultured cells and neuronal expression in rat brain Hum Mol Genet 2001,10 477-484
- 7 Bespalova IN, Van Camp G, Bom SJH, Brown DJ, Cryns K, DeWan AT, Erson AE, Flothmann K, Kunst HPM, Kurnool P, Sivakumaran TA, Cremers CWRJ, Leal SM, Burmeister M, Lesperance MM Mutations in the Wolfram syndrome 1 gene (*WFS1*) are a common cause of low frequency sensorineural hearing loss Hum Mol Genet 2001,10 2501-2508
- 8 Young T-L, Ives E, Lynch E, Person R, Snook S, MacLaren L, Cator T, Griffin A, Fernandez B, Lee MK, King M-C Non-syndromic progressive hearing loss DFNA38 is caused by heterozygous missense mutation in the Wolfram syndrome gene *WFS1* Hum Mol Genet 2001,10 2509-2514

- 9 Cremers CWRJ, Wijdeveld PGAB, Pinckers AJLG. Juvenile diabetes mellitus, optic atrophy, hearing loss, diabetes insipidus, atonia of the urinary tract and the bladder, and other abnormalities (Wolfram syndrome) A review of 88 cases from the literature with personal observations on 3 new patients *Acta Paediatr Scand Suppl* 1977;264 1-16
- 10 Pennings RJE, Bom SJH, Cryns K, Flothmann K, Huygen PLM, Kremer H, Van Camp G, Cremers CWRJ. Progression of low-frequency sensorineural hearing loss (DFNA6/14-WFS1) *Arch Otolaryngol Head Neck Surg* 2003;129 421-426
- 11 Cryns K, Pfister M, Pennings RJE, Bom SJH, Flothmann K, Caethoven G, Kremer H, Schatteman I, Kóln KA, Tóth T, Kupka S, Blin N, Nürnberg P, Thiele H, van de Heyning PH, Reardon W, Stephens D, Cremers CWRJ, Smuth RJH, Van Camp G Mutations in the WFS1 gene that cause low-frequency sensorineural hearing loss are small non-inactivating mutations. *Hum Genet* 2002;110:389-394
- 12 Cryns K, Sivakumaran TA, Van den Ouweland JMW, Pennings RJE, Cremers CWRJ, Flothmann K, Young T-L, Smuth RJH, Lesperance MM, Van Camp G. Mutational spectrum of the WFS1 gene in Wolfram syndrome, nonsyndromic hearing impairment, diabetes mellitus and psychiatric disease *Hum Mutat* 2003;22:275-287
- 13 Higashi K. Otolologic findings of DIDMOAD syndrome. *Am J Otol* 1991;12:57-60
- 14 Van den Ouweland JMW, Cryns K, Pennings RJE, Walraven I, Janssen GMC, Maassen JA, Van Swieten JC, Veldhuijzen BFE, Arntzenius AB, Lindhout D, Cremers CWRJ, Van Camp G, Dikkeschei LD Molecular characterization of WFS1 in patients with Wolfram syndrome *J Mol Diagnost* 2003;5 88-95
- 15 Ohata T, Koizumi A, Kayo T, Shoji Y, Watanabe A, Monoh K, Higashi K, Ito S, Ogawa O, Wada Y, Takada G. Evidence of increased risk of hearing loss in heterozygous carriers in a Wolfram syndrome family *Hum Genet* 1998;103:470-474
- 16 Kadayıfçı A, Kepekçi Y, Coşkun Y, Huang Y. Wolfram syndrome in a family with variable expression *Acta Medica (Hradec Kralove)* 2001;44:115-118.
- 17 The Vanderbilt University Hereditary Deafness Study Group Dominantly inherited low-frequency hearing loss. *Arch Otolaryngol* 1968;88:242-250.
- 18 Huygen PLM, Bom SJH, Van Camp G, Cremers CWRJ The clinical presentation of the DFNA loci where causative genes have not yet been cloned DFNA4, DFNA6/14, DFNA7, DFNA16, DFNA20 and DFNA21 In: Cremers CWRJ, Smuth RJH (eds) *Advances in Oto-Rhino-Laryngology*, 2003, volume 61 Basel: Karger pp:98-106.
- 19 Bom SJH, Van Camp G, Cryns K, Admiraal RJC, Huygen PLM, Cremers CWRJ. Autosomal dominant low-frequency hearing impairment (DFNA6/14) a clinical and genetic family study. *Otol Neurotol* 2002;23:876-884.
- 20 Hardy C, Khanim F, Torres R, Scott-Brown M, Seller A, Poulton J, Collier D, Kirk J, Polymeropoulos M, Latif F, Barrett T Clinical and molecular genetic analysis of 19 Wolfram syndrome kindreds demonstrating a wide spectrum of mutations in WFS1 *Am J Hum Genet* 1999;65:1279-1290
- 21 Gómez-Zaera M, Strom TS, Rodríguez B, Estivill X, Meitinger T, Nunes V. Presence of a major WFS1 mutation in Spanish Wolfram syndrome pedigrees. *Mol Genet Metab* 2001;72:72-81
- 22 Bom SJH, De Leenheer EMR, Lemaire FX, Kemperman MH, Verhagen WIM, Marres HAM, Kunst HPM, Ensink RJH, Bosman AJ, Van Camp G, Cremers FPM, Huygen PLM, Cremers CWRJ. Speech recognition scores related to age and degree of hearing impairment in DFNA2/KCNQ4 and DFNA9/COCH. *Arch Otolaryngol Head Neck Surg* 2001;127:1045-1048
- 23 Marres HAM, van Ewijk M, Huygen PLM, Kunst HPM, Van Camp G, Coucke P, Cremers CWRJ. Inherited nonsyndromic hearing loss. An audiovestibular study in a large family with autosomal dominant progressive hearing loss related to DFNA2 *Arch Otolaryngol Head Neck Surg* 1997;123:573-577.
- 24 De Leenheer EMR, van Zuijlen DA, Van Laer L, Van Camp G, Huygen PLM, Huizing EH, Cremers CWRJ. Further delineation of the DFNA5 phenotype Results of speech recognition tests. *Ann Otol Rhinol Laryngol* 2002;111 639-641
- 25 Mtanda AT, Cruysberg JRM, Pinckers AJLG Optic atrophy in Wolfram syndrome *Ophthalm Paediatr Genet* 1986;7:159-165.
- 26 Komatsu K, Nakamura N, Ghadami M, Matsumoto N, Kishino T, Ohta T, Niihara N, Yoshiura K Confirmation of genetic homogeneity of nonsyndromic low-frequency sensorineural hearing loss by linkage analysis and a DFNA6/14 mutation in a Japanese family. *J Hum Genet* 2002;47:395-399.
- 27 Elsheikh M, Dunger DB, Conway GS, Wass JAH. Turner's syndrome in adulthood. *End Rev* 2002; 23:120-140.
- 28 Lee JH, Marcus DC. Estrogen acutely inhibits ion transport by isolated stria vascularis. *Hear Res* 2001;158:123-130
- 29 Garcia-Segura LM, Azcoitia I, DonCarlos LL. Neuroprotection by estradiol. *Prog Neurobiol* 2001;63 29-60.



- 30 Ropero AB, Soria B, Nadal A A nonclassical estrogen membrane receptor triggers rapid differential actions in the endocrine pancreas. *Mol Endocrinol* 2002;16 497-505
- 31 Hoff AL, Kremen WS, Wieneke MH, Lauriello J, Blankfeld HM, Faustman WO, Csernansky JC, Nordahl TE Association of estrogen levels with neuropsychological performance in women with schizophrenia *Am J Psychiatry* 2001;158:1134-1139
- 32 De Leenheer EMR, Huygen PLM, Coucke PJ, Admiraal RJC, Van Camp G, Cremers CWRJ Longitudinal and cross-sectional phenotype analysis in a new, large Dutch DFNA2/*KCNQ4* family *Ann Otol Rhinol Laryngol* 2002;111:267-274.

# CHAPTER 5

AUTOSOMAL DOMINANT

NONSYNDROMIC LOW-

FREQUENCY HEARING

IMPAIRMENT (DFNA6/14)



# 5.1

---

## PROGRESSION OF LOW-FREQUENCY SENSORINEURAL HEARING LOSS (DFNA6/14-WSF1)

R.J.E. Pennings  
S.J.H. Bom  
K. Cryns  
K. Flothmann  
P.L.M. Huygen  
H. Kremer  
G. Van Camp  
C.W.R.J. Cremers



---

## INTRODUCTION

Thirty-four years ago, the Vanderbilt University Hereditary Deafness Study group reported on a large family with remarkable low-frequency sensorineural HI with an autosomal dominant pattern of inheritance.<sup>1</sup> Konigsmark et al. described several years later three more families harbouring a dominant low-frequency HI trait.<sup>2</sup> All families generally displayed an upward-sloping audiogram pattern. Nowadays, however, characterisation of nonsyndromic forms of hereditary HI tends to be more based on genetic characteristics than on clinical findings. The different loci for nonsyndromic autosomal dominant forms of HI are designated DFNA (DFN for deafness and A for autosomal dominant) and numbered in chronological order of discovery. Today 40 loci are known to cause autosomal dominant nonsyndromic HI.<sup>3</sup> Only two of them, DFNA1 and DFNA6/14, are characterised by predominant low-frequency HI.

Recently, it became apparent that the *WFS1* gene harbours heterozygous mutations in DFNA6 as well as DFNA14 and that DFNA6 and DFNA14 represent the same locus further designated as DFNA6/14.<sup>4</sup> Homozygous mutations in the *WFS1* gene account for the autosomal recessive Wolfram syndrome.<sup>5,6</sup> To date, three families with a heterozygous mutation in the *WFS1* gene have been clinically described: USA<sup>1</sup> (L829P mutation<sup>4</sup>), Dutch I<sup>7</sup> (T699M<sup>4</sup>) and Dutch II<sup>8</sup> (A716T<sup>4</sup>). All showed mild progression of HI, however, in only one family (Dutch II) this was beyond presbycusis.<sup>9</sup> Brodewolf et al.<sup>10</sup> recently introduced a German DFNA6/14 family harbouring a low-mid frequency HI, based on linkage. Young et al.<sup>11</sup> recently described a Newfoundland kindred harbouring the same *WFS1* mutation (A716T) as detected in family Dutch II.

This report describes the type of HI in two additional Dutch DFNA6/14 families (Dutch III and Dutch IV) that harbour two different mutations in the *WFS1* gene, G674E and G674V respectively.

*Family Dutch III*

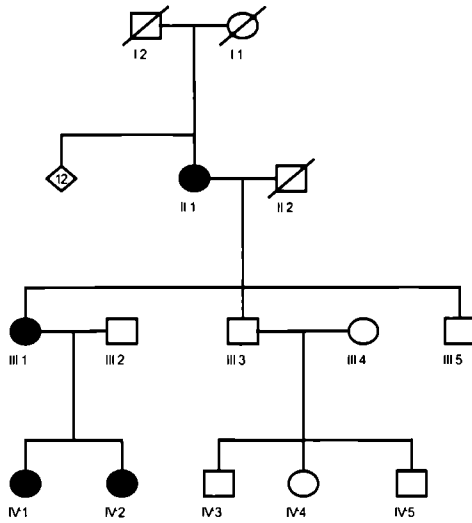

*Family Dutch IV*

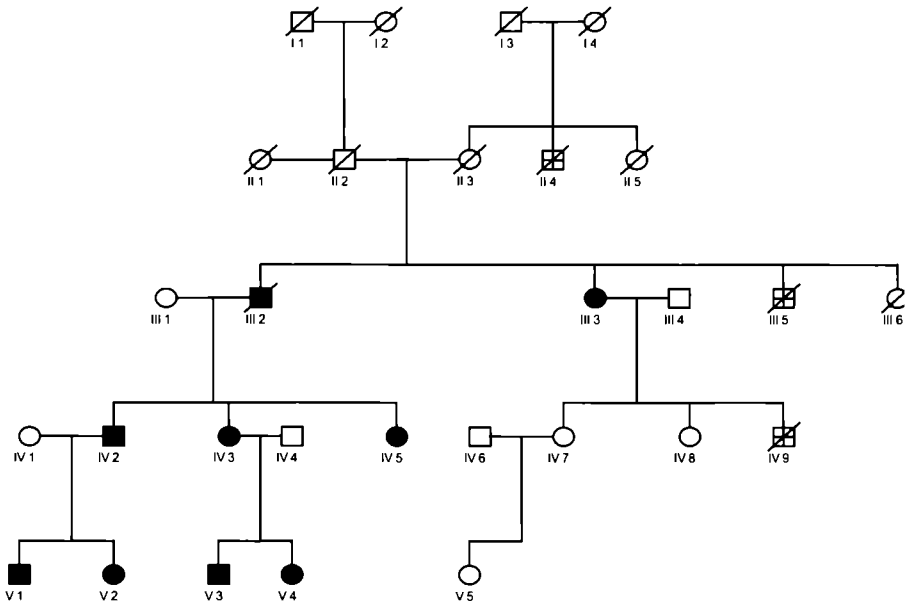

Figure 1. Pedigrees of the families Dutch III and Dutch IV. Square, man; circle, woman; dashed symbol, deceased; crossed symbol, Duchenne-type muscular dystrophy; filled symbol, low-frequency hearing impairment

---

## PATIENTS AND METHODS

In two Dutch families, Dutch III and Dutch IV (Figure1) the *WFS1* gene was analysed for mutations, because both families disclosed typical low-frequency tone audiograms. Four affected individuals from family Dutch III have a G674V mutation and in eight affected individuals from family Dutch IV the G674E mutation was found.<sup>12</sup> From the pedigree it was concluded that the deceased individual III:2 from family Dutch IV harboured the same mutation as the other affected persons in this family.

In this study we establish the audiometric profile and speech recognition performance in DFNA6/14 at various ages. Medical history was taken, especially focusing on acquired and syndromic conditions. Otoscopy was performed and previous audiologic data were retrieved, including data of one deceased individual (III:2 of family Dutch IV). Pure tone (binaural mean of air and bone conduction) threshold (octave frequencies 0.25-8 kHz) and speech recognition scores (mean of monaural maximum phoneme scores) were assessed in a sound treated room according to the norms defined by the International Organization for Standardization (ISO).<sup>13,14</sup> In one case (III:3 of family Dutch IV) the data of one ear (left) were excluded because of previous ear surgery.

Cross-sectional linear regression analysis (threshold on age) was performed on last-visit data using the Prism 3.02 program (GraphPad, San Diego, CA, USA). Progression (slope) was evaluated in relation to presbycusis. Progression was called significant when a significant positive slope ( $P < 0.025$ ) was detected for the raw threshold data at a sufficiently high number of different sound frequencies ( $P < 0.05$  in the appropriate binomial distribution). The significance of progression was also evaluated for threshold data including individual (age- and sex-related) correction for median ( $P_{50}$ ) presbycusis according to the ISO 7029 norm.<sup>15</sup>

ARTA were derived from the results of the cross-sectional regression analysis (raw data). Individual longitudinal regression analysis, also including correction for presbycusis, was performed in three cases (III:1, IV:1 and IV:2 of family Dutch III).

Cross-sectional regression analysis of speech audiometry data involved maximum phoneme recognition scores (%Correct) derived from individual performance-



intensity plots. Regression analysis was performed for performance-age plots (score on age), as well as performance-impairment plots (score on average of pure tone thresholds at 0.5, 1 and 2 kHz, i.e.  $PTA_{0.5-2\text{ kHz}}$ ). Speech recognition scores were fitted by a linear regression line. The X coordinate relating to the 90% Correct score ( $X_{90}$ ) was called onset age for  $X = \text{age}$  and onset level for  $X = PTA_{0.5-2\text{ kHz}}$ . The 95% confidence interval for  $X_{90}$  was obtained by performing nonlinear regression analysis using the alternative equation for the linear regression line,  $Y = \text{slope}(X - X_{90}) + 90$ . Student's t test (including Welch's correction if Bartlett's test detected unequal variances) was used to test on differences in  $X_{90}$  between the families. Slope was called deterioration rate for  $X = \text{age}$  and deterioration gradient for  $X = PTA_{0.5-2\text{ kHz}}$ .

Analysis of covariance (ANCOVA) was used to compare slopes and intercepts between different regression lines pertaining to either different frequencies within a given family or pertaining to the families at a given frequency. Slopes and intercepts were pooled if that was allowed for.

Vestibulo-ocular responses were evaluated in two cases (IV:2 and IV:5 from family Dutch IV) using electronystagmography with computer analysis. Saccadic, smooth pursuit, optokinetic and vestibular nystagmus responses were evaluated. Vestibular stimulation comprised rotatory and caloric tests. Details and normal values have been previously described.<sup>14</sup>

## RESULTS

Four individuals from family Dutch III and nine individuals from family Dutch IV showed low-frequency HI. Family Dutch IV also harbours a Duchenne-type muscular dystrophy trait: three affected boys (Figure 1, crossed symbols) died at young age without any HI by history.

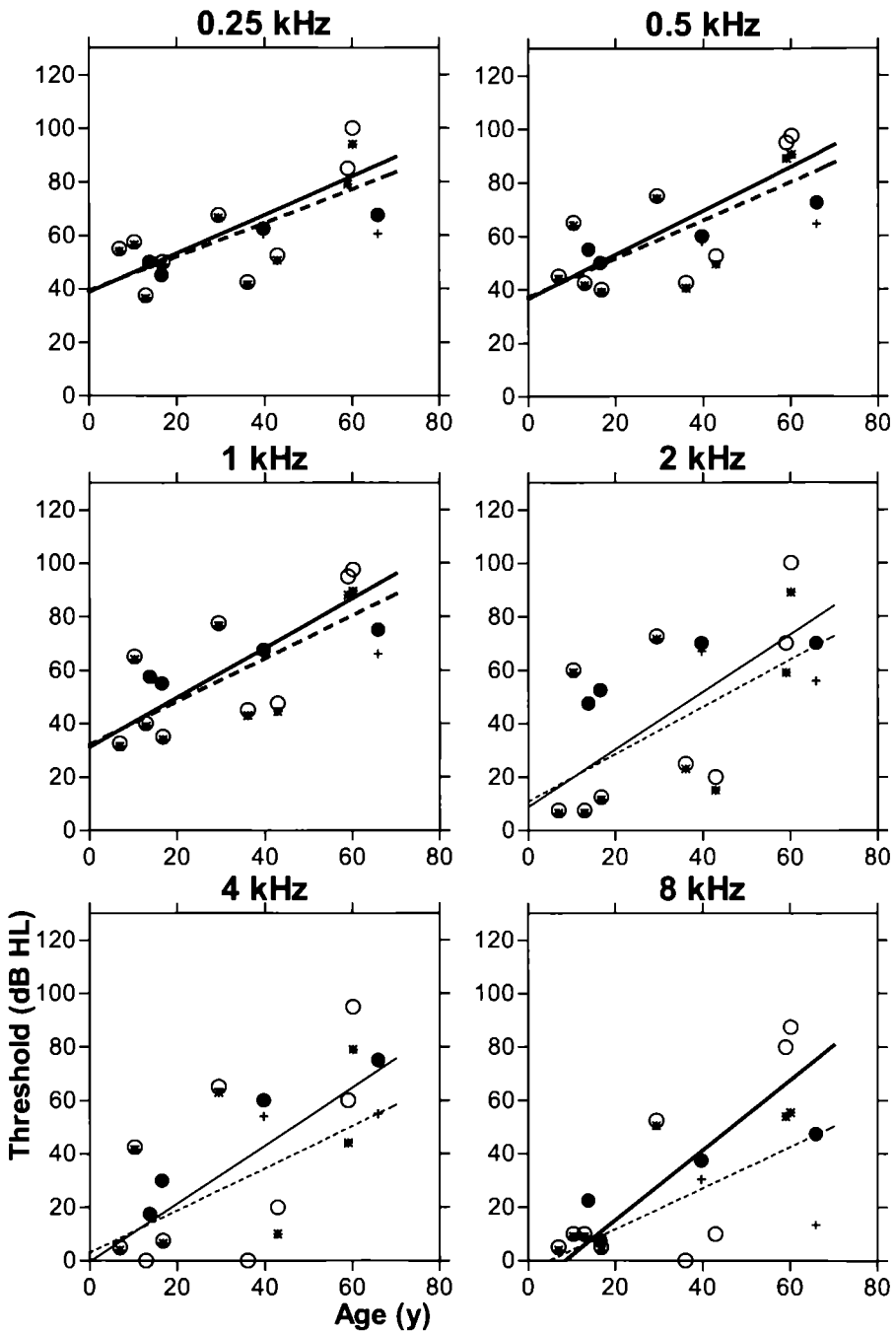

Figure 2. Cross-sectional analysis of binaural mean air conduction threshold (dB HL) for family Dutch IV (open symbols) related to the patient's age (year). Regression lines are included, dotted lines relate to age-corrected threshold (small asterisks). Bold lines indicate significant progression. Threshold data for family Dutch III are also included (dots and small crosshair symbols), however, without the corresponding regression lines.

Cross-sectional analysis (threshold on age) was performed in both families. The main results are shown in Figure 2. The family Dutch III (dots) did not reveal substantially different scattering of threshold data points compared to family Dutch IV (circles). Both families showed significant progression (bold lines in Figure 2, pertaining only to family Dutch IV). Family Dutch IV revealed no significant difference in progression between the frequencies (raw data, pooled ATD 1.0 dB/year). There was no significant difference in progression (raw data) between the families as tested for each separate frequency. However, following correction for presbycusis, family Dutch IV (small asterisks) still showed significant progression, whereas this was not the case for family Dutch III (small crosshair symbols).

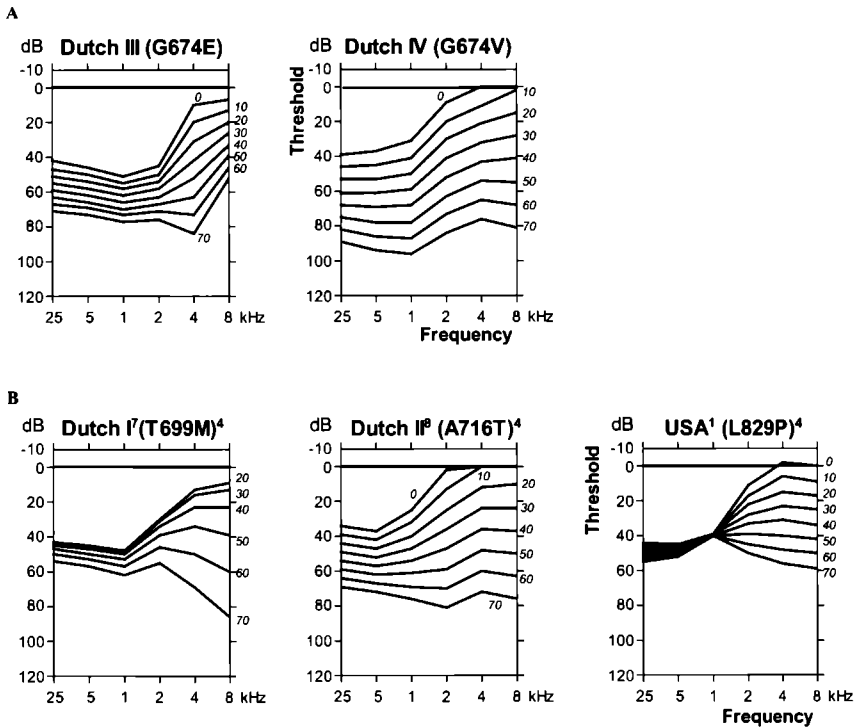

Figure 3. ARTA for five different DFNA6/14 (A present, B previously reported<sup>1,7,8</sup>) families arranged according to the *WFS1* mutation.<sup>4,12</sup> Age (year) in *italics*.

ARTA for these two families displayed an ascending audiometric configuration from low-frequency thresholds (fairly flat at 0.25-1 kHz) of about 40-70 dB in

family Dutch III and 40-90 dB in family Dutch IV (Figure 3a). The flat threshold configuration included 2 kHz in family Dutch III. In the younger individuals, the thresholds at 4-8 kHz were generally close to normal, especially in family Dutch IV.

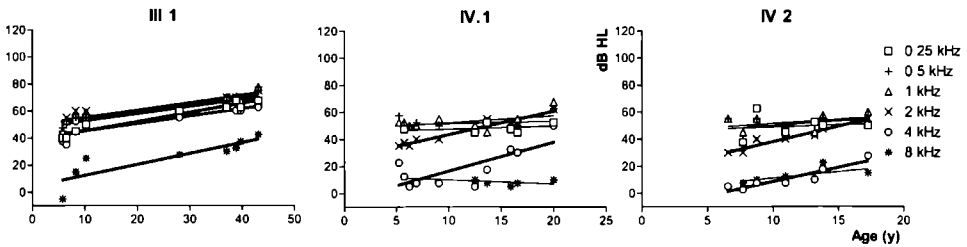

Figure 4 Longitudinal analyses (raw threshold data) for separate frequencies (0.25-8 kHz) in the individuals III 1, IV 1 and IV 2 from family Dutch III. Bold lines indicate significant progression.

In three cases (III:1, IV:1 and IV:2 of family Dutch III) longitudinal regression analysis of pure tone audiograms could be performed. Significant progression was detected in all of them (Figure 4) and was also resistant to correction for presbycusis. ARTA derived for these longitudinal analyses (plots not shown) appeared to be fairly similar to those obtained for the cross-sectional analysis (Figure 3a).

Figure 5 covers the analyses pertaining to speech recognition scores (performance-age plot left, performance-impairment plot right) for the families Dutch III (dots) and Dutch IV (circles). The regression lines in the left panel show a fairly slow decrease in score with increasing age. Onset age for family Dutch III was 25 year (95% confidence interval 16-34 year); the deterioration rate was 0.8 %/year (95% confidence interval 0.5-1.1 %/year). The parameter values for family Dutch IV were fairly similar: onset age 28 year (95% CI 18-38 year) and deterioration rate 0.5 %/year (95% CI 0.1-0.9%/year). A significant difference in performance between the families was only found in relation to the level of impairment (Figure 5, right). In family Dutch III (dashed line), the deterioration gradient was almost 2%/dB with a 95% confidence interval of 1.4-2.6%/dB. In family Dutch IV (continuous line), it was 0.45%/dB with a 95% CI of 0.3-0.6%/dB. There was no significant difference in onset level between both families (Dutch III, 58 dB HL with 95% CI 55-61 dB and Dutch IV, 51 dB with 95% CI 42-60 dB).

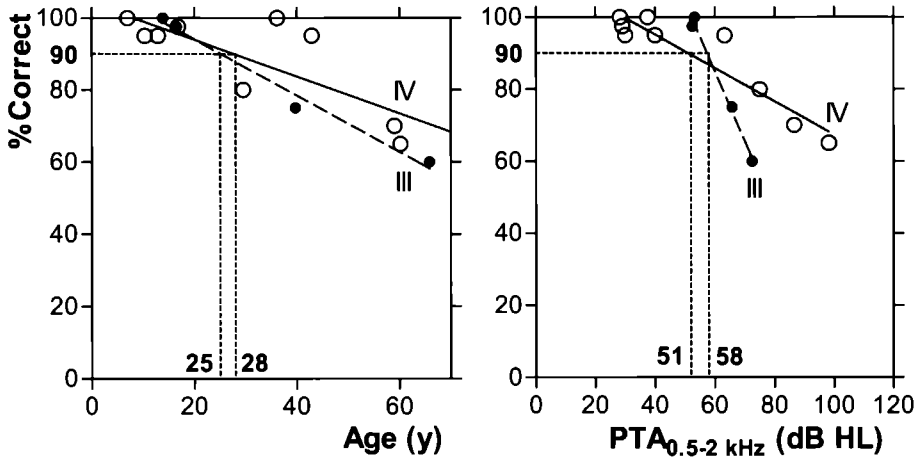

Figure 5 Cross-sectional analysis of mean phoneme monaural (right and left) recognition score (%Correct) related to age (in year, left panel) and (binaural mean) PTA<sub>0.5-2 kHz</sub> (in dB HL, right panel) for family Dutch III (filled symbols) and family Dutch IV (open symbols). Linear regression lines are shown with a Roman figure indicating the family. Dotted lines and bold figures relate to the 90%Correct score.

None of the patients reported any consistent vestibular symptoms and the two individuals examined, showed normal ocular motor and vestibular responses.

## DISCUSSION

The Dutch III (longitudinal analyses) and Dutch IV (cross-sectional analyses) families showed similar progression that persisted after correction for presbycusis. On evaluation of speech recognition scores, the performance-impairment plots were significantly different between the 2 kindreds, while the performance-age plots were fairly similar.

Although nonsyndromic autosomal dominant HI is a heterogeneous condition, the subgroup of loci predominantly affecting the lower frequencies is homogeneous to some extent. DFNA1 was the first locus identified with a nonsyndromic autosomal dominant HI trait. It is located on chromosome 5q31 and is characterised as a progressive low-frequency type of HI.<sup>17,18</sup> Lynch et al.<sup>19</sup> identified the responsible mutation in the *DIAPH1* gene in a large Costa Rican

family. To our knowledge, no other families showing linkage to the DFNA1 locus have been described.

Lesperance et al.<sup>20</sup> identified a second locus for dominant low-frequency HI (DFNA6) on chromosome 4p16.3 in the American family in whom the corresponding phenotype had been outlined by the Vanderbilt University Hereditary Deafness Study Group.<sup>1</sup> Predominant involvement of the frequencies 0.25-1 kHz was found. Recently, the raw data published in that report were re-analysed in a cross-sectional analysis and no significant progression beyond presbycusis was found.<sup>8</sup>

In the Dutch I family, Van Camp et al.<sup>21</sup> discovered a third locus (DFNA14) associated with low-frequency sensorineural HI on chromosome 4p16.3, close to the DFNA6 locus but without an apparent overlap. Kunst et al.<sup>7</sup> described the audiometric presentation in this Dutch I family and demonstrated progression of HI but not beyond that attributable to presbycusis.

The Dutch II family was linked to a larger chromosomal region comprising both DFNA6 and DFNA14. Progression was mild but significant, and ranged from 0.5 dB/year at 0.25 kHz to 1.3 dB/year at 8 kHz. Significant progression persisted after correction for presbycusis.<sup>9</sup> Recently Brodwolf et al.<sup>10</sup> described an additional family linked to DFNA6/14 showing a non-progressive low-frequency HI. Young et al.<sup>11</sup> have reported another low-frequency HI trait, designated DFNA38, in a Newfoundland family harbouring the same mutation (A716T) in the *WFS1* gene as was found in the Dutch II family.

ARTA for the clinically described families are depicted in Figure 3; they demonstrate 2 types, with (G674V and A716T) and without (T699M and L829P) progression beyond presbycusis at low frequencies (0.25-1 kHz). The G674E mutation (Dutch III) seems to have caused a progression that is intermediate between these 2 extremes. Cross-sectional analysis of this family did not indicate progression after presbycusis correction, but this may have been because of a lack of sufficient number of observations. However, longitudinal analysis in 3 individuals from this family, involving more observations, demonstrated progression beyond presbycusis.

Speech recognition scores have also been evaluated for some individuals of the Dutch II family.<sup>9</sup> The scores for younger individuals (< 32 years) were within the 90% to 100% range, which is in line with the mean onset ages of 25 and 28 years found for the Dutch III and IV families, respectively. The mean onset levels for these 2 families ranged from 50 to 60 dB HL. There was no substantial difference in pure-tone audiogram findings between the Dutch III and IV families, although the 2 kHz threshold appeared to be more affected in the Dutch III family (i.e. in line with a flat threshold at 0.25-2 kHz). Speech performance scores relative to age were not substantially different. However, a significant difference in speech performance relative to the level of HI was detected. This difference may have been related to the worse pure-tone threshold found at 2 kHz in the Dutch III family.

The point mutations in these 2 families cause a missense mutation of the same amino acid, G674. This glycine is substituted by glutamic acid in the Dutch III family and by valine in the Dutch IV family. The phenotype relating to the A716T mutation<sup>4</sup> was similar to that in these families.

Recently, it was demonstrated in 7 families that heterozygous mutations in the *WFS1* gene are responsible for traits linked to DFNA6/14.<sup>4</sup> In the original family demonstrating DFNA6, a key recombinant that excluded the DFNA14 candidate region had actually been based on a phenocopy. This led to an incorrect localisation of DFNA6, while in fact DFNA6 and DFNA14 represent a single locus.

The *WFS1* gene encodes the protein wolframin and is homozygously mutated in the Wolfram or DIDMOAD (Diabetes Insipidus, Diabetes Mellitus, Optic Atrophy and Deafness) syndrome. The minimum features required for the diagnosis are type I diabetes mellitus and optic atrophy. However, diabetes insipidus (described in 54-58% of cases) and "deafness" (described in 51-62%) are also common features of this syndrome.<sup>22</sup> This autosomal recessive syndrome seems to be associated with a high-frequency HI rather than the low-frequency impairment found in the present families.<sup>23,24</sup> This rare syndrome has a prevalence of 1 in 770,000 in the United Kingdom.<sup>25</sup> Wolframin, encoded by *WFS1*, is a transmembrane protein.<sup>5,6</sup> It has been localised to the endoplasmic reticulum (ER) and probably plays a role in membrane trafficking, protein processing and regulation of ER calcium homeostasis.<sup>26</sup> However, its exact location and role in the cochlea remain obscure. Electrophysiologic, magnetic resonance imaging and

neuropathologic studies<sup>27-29</sup> of this syndrome have shown general progressive degeneration of the central and peripheral nervous systems, including the vestibulocochlear nerve. Ohata et al.<sup>30</sup> described an increased risk of HI and diabetes mellitus in heterozygous carriers. Unfortunately, no frequencies were specified and HI was defined as an overall threshold greater than 20 dB HL. Young et al.<sup>11</sup> described an individual in the Newfoundland family who was a homozygous carrier and who had diabetes mellitus at young age and other clinical features reminiscent of Wolfram syndrome. However, this individual was not affected by optic atrophy. Therefore, it seems possible that carriers of the Wolfram syndrome show low-frequency HI similar to that found in DFNA6/14.

## REFERENCES

- 1 The Vanderbilt University Hereditary Deafness Study Group Dominantly inherited low-frequency hearing loss Arch Otolaryngol 1968;88 242-250
- 2 Konigsmark BW, Mengel M, Berlinn CI. Familial low frequency hearing loss Laryngoscope 1971;81 759-771.
- 3 Camp G, Smuth RJH Hereditary Hearing Loss Homepage (HHH) Available from: URL <http://www.dnalab-www.uia.ac.be/dnalab/hhh/>. Accessed September 2001.
- 4 Bespalova IN, Van Camp G, Bom SJH, Brown DJ, Cryns K, DeWan AT, Erson AE, Flothmann K, Kunst HPM, Kurnool P, Sivakumaran TA, Cremers CWRJ, Leal SM, Burmeister M, Lesperance MM Mutations in the Wolfram syndrome 1 gene (*WFS1*) are a common cause of low frequency sensorineural hearing loss Hum Mol Genet 2001;10:2501-2508
- 5 Strom TM, Hörtnagel K, Hofmann S, Gekeler F, Scharfe C, Rabl W, Gerbitz K, Meitinger T Diabetes insipidus, diabetes mellitus, optic atrophy and deafness (DIDMOAD) caused by mutations in a novel gene (*wolframin*) coding for a predicted transmembrane protein Hum Mol Genet 1998;7 2021-2028
- 6 Inoue H, Tanizawa Y, Wasson J, Behn P, Kalidas K, Bernal-Mizrachi E, Mueckler M, Marshall H, Donis-Keller H, Crock P, Rogers D, Mikuni M, Kumashiro H, Highashi K, Sobue G, Oka Y, Permutt MA A gene encoding a transmembrane protein is mutated in patients with diabetes mellitus and optic atrophy (Wolfram syndrome). Nat Genet 1998;20:143-148.
- 7 Kunst HPM, Marres HAM, Huygen PLM, Van Camp G, Joosten F, Cremers CWRJ Autosomal dominant non-syndromal low-frequency hearing impairment linked to chromosome 4p16 (DFNA14)-statistical analysis of hearing threshold in relation to age and evaluation of vestibulo-ocular functions Audiology 1999;38.165-173.
- 8 Huygen PLM, Bom SJH, Van Camp G, Cremers CWRJ. The clinical presentation of the DFNA loci where causative genes have not yet been cloned. DFNA4, DFNA6/14, DFNA7, DFNA16, DFNA20 and DFNA21. In Cremers CWRJ, Smith RJH (eds) Genetic hearing impairment Its clinical presentations. Advances in Oto-Rhino-Laryngology, vol.61 Basel: Karger 2002, 61-98-106
- 9 Bom SJH, Van Camp G, Caethoven G, Admiraal RJC, Huygen PLM, Cremers CWRJ Autosomal dominant low-frequency hearing impairment (DFNA6/14) a clinical and genetic family study Otol Neurotol 2002;23 8676-884.
- 10 Brodwolf S, Bøddeker IR, Ziegler A, Rausch P, Kunz J Further evidence for linkage of low-mid frequency hearing impairment to the candidate region on chromosome 4p16.3 Clin Genet 2001;60 155-160.
- 11 Young T-L, Ives E, Lynch E, Person R, Snook S, MacLaren L, Cator T, Griffn A, Fernandez B, Lee MK, King M-C. Non-syndromic progressive hearing loss *DFNA38* is caused by heterozygous missense mutation in the Wolfram syndrome gene *WFS1*. Hum Mol Genet 2001;10 2509-2514.
- 12 Cryns K, Pfister M, Pennings RJE, Bom SJH, Flothmann K, Caethoven G, Kremer H, Schatteman I, Köln KA, Tóth T, Kupka S, Blin N, Nürnberg P, Thiele H, Van De Heyning PH, Reardon W, Stephens D,



- Cremers CWRJ, Smith RJH, Van Camp G. Mutations in the WFS1 gene that cause low-frequency sensorineural hearing loss are small non-inactivating mutations. *Hum Genet* 2002;110:389-394
- 13 International Organization for Standardization. ISO 389: Acoustics Standard Reference Zero for the Calibration of Pure Tone Air Conduction Audiometers Geneva, Switzerland, International Organization for Standardization, 1985
- 14 International Organization for Standardization. ISO 8253-1: Acoustics: Audiometric Test Methods, I. Basic Pure Tone Air and Bone Conduction Threshold Audiometry Geneva, Switzerland, International Organization for Standardization, 1989
- 15 International Organization for Standardization ISO 7029: Acoustics Threshold of Hearing by Air Conduction as a Function of Age and Sex for Otologically Normal Persons. Geneva, Switzerland, International Organization for Standardization, 1984.
- 16 Kunst HPM, Huybrechts C, Marres HAM, Huygen PLM, Van Camp G, Cremers CWRJ The phenotype of DFNA13, COL11A2: nonsyndromic autosomal dominant mid-frequency and high-frequency sensorineural hearing impairment. *Am J Otol* 2000;21:181-187.
- 17 León PE, Ravens H, Lynch ED, Morrow JE, King M-C. The gene for an inherited form of deafness maps to chromosome 5q31. *Proc Natl Acad Sci USA* 1992;89:5181-5184
- 18 Lalwani AK, Jackler RK, Sweetow RW et al Further characterization of the DFNA1 audiovestibular phenotype. *Arch Otolaryngol Head Neck Surg* 1998;124:699-702.
- 19 Lynch ED, Lee MK, Morrow JE, Welch PL, León PE, King M-C Nonsyndromic deafness DFNA1 associated with mutation of a human homolog of the drosophila gene diaphanous. *Science* 1997;278:1315-1318
- 20 Lesperance MM, Hall JW III, Bess FH, Fukushima K, Jain PK, Ploplis B, San Agustín TB, Skarka H, Smith RJH, Wills M, Wilcox ER A gene for autosomal dominant nonsyndromic hereditary hearing impairment maps to 4p16.3. *Hum Mol Genet* 1995;4:1967-1972
- 21 Van Camp G, Kunst H, Flothmann K, McGuirt W, Wauters J, Marres H, Verstreken M, Bessalova IN, Burmeister M, Van de Heyning PH, Smith RJH, Willems PJ, Cremers CWRJ, Lesperance MM A gene for autosomal dominant hearing impairment (DFNA14) maps to a region on chromosome 4p16.3 that does not overlap the DFNA6 locus. *J Med Genet* 1999;36:532-536
- 22 Fuqua JS Wolfram syndrome. Clinical and genetic aspects. *The Endocrinologist* 2000;10:51-59.
- 23 Higashi K. Otolologic findings of DIDMOAD syndrome. *Am J Otol* 1991;12:57-60.
- 24 Cremers CWRJ, Wijdeveld PGAB, Pinckers AJLG Juvenile diabetes mellitus, optic atrophy, hearing loss, diabetes insipidus, atonia of the urinary tract and the bladder, and other abnormalities (Wolfram syndrome). A review of 88 cases from the literature with personal observations on 3 new patients. *Acta Paediatr Scand Suppl.* 1977;264:1-16.
- 25 Barrett T, Bunday S, Macleod A Neurodegeneration and diabetes: UK nationwide study of Wolfram (DIDMOAD) syndrome. *Lancet* 1995;346:1458-1463.
- 26 Takeda K, Inoue H, Tanazawa Y, Matsuzaki Y, Oba J, Watanabe Y, Shinoda K, Oka Y WFS1 (Wolfram syndrome 1) gene product predominant subcellular localization to endoplasmic reticulum in cultured cells and neuronal expression in rat brain. *Hum Mol Genet* 2001;10:477-484.
- 27 Blasi C, Pierelli F, Rispoli E, Saponara M, Vingolo E, Andreani D. Wolfram's syndrome: a clinical, diagnostic and interpretative contribution. *Diabetes care* 1986;9:521-528.
- 28 Rando TA, Horton JC, Layzer RB Wolfram syndrome: Evidence of a diffuse neurodegenerative disease by magnetic resonance imaging. *Neurology* 1992;42:1220-1224
- 29 Génuis D, Dávalos A, Molins A, Ferrer I. Wolfram syndrome: a neuropathological study. *Acta Neuropathol* 1997;93:426-429.
- 30 Ohata T, Koizumi A, Kayo T, Shoji Y, Watanabe A, Monoh K, Higashi K, Ito S, Ogawa O, Wada Y, Takada G. Evidence of an increased risk of hearing loss in heterozygous carriers in a Wolfram syndrome family. *Hum Genet* 1998;103:470-474.

# CHAPTER 6

## GENERAL DISCUSSION



Hereditary deafblindness is a rare combination of two sensory handicaps that affect daily-life activities. Usher syndrome and Wolfram syndrome are the main deafblindness syndromes examined in this study. About 50% of the deafblind patients suffer from Usher syndrome, whereas Wolfram syndrome is rare with a broad spectrum of additional symptoms. Since several years, it is known that different mutations in the same gene may cause syndromic as well as nonsyndromic HI. Usher syndrome type Id and DFNB12 are, for example, both caused by mutations in the *CDH23* gene. Another example is that recessive mutations in *WFS1* may be causing Wolfram syndrome, whereas dominant mutations in this gene may cause DFNA6/14, a nonsyndromic type of low-frequency HI whose phenotype is described in Chapter 5. The genes, which are involved in hereditary deafblindness, encode proteins with a specific function in the eye and ear. After the identification of the gene and its nucleotide and amino acid sequence, it may be possible to specify predictions about certain domains of the protein and about the function of the protein in the eye and ear. Expression studies and functional studies of these proteins can reveal important details about the function of the protein. It is, however, important to realise that without performing family studies and genotype-phenotype correlation studies, the identification of genes is much more difficult. In this chapter the main results of the studies covered by this thesis are discussed and recommendations are made for future research.

## CHARACTERISATION OF PROGRESSIVE TYPES OF HEARING IMPAIRMENT

In **Chapter 2** it is shown that it is possible to characterise progressive types of autosomal dominantly inherited nonsyndromic HI traits. On the basis of cross-sectional and/or longitudinal regression analyses of pure-tone thresholds plotted against age, ARTA can be derived. ARTA show the progression of HI in an audiogram-like format and cover, where possible, decade steps in age. The TFA is a second tool that can be used for statistical testing between the different HI traits. The developed and described tools are useful for the evaluation of HI in newly identified families with hereditary HI. After analysing the pure-tone thresholds of affected family members, ARTA and a TFA can be derived and compared to normal values for TFA, obtained from families with a known genotype. As the number of examined and genotyped families will increase, the normal values for

TFA will become more and more specific. The molecular geneticists can thus be advised, on the basis of the ARTA and TFA, to perform mutation analysis of specific genes prior to costly genome scans or other types of expensive time-consuming research. In addition, when pure tone audiograms of several affected family members are available, it is possible to perform a specific mutation analysis in DNA from the proband that is guided by the audiometric analysis. This way, family studies can be performed in a cost-effective way and become less time-consuming. It is therefore recommended always to perform such a type of analysis prior to gene identification studies.

The ARTA are also valuable for genetic and individual counselling. Although intrafamilial differences can be found in varying degrees in families, a general prognosis of the progression of HI can be given on the basis of the ARTA. Future research should focus on further development of normal values for the TFA of specific genotypes.

## GENETIC AND CLINICAL FEATURES OF USHER SYNDROME

In **Chapter 3** of this thesis, the clinical and genetic features of different subtypes of Usher syndrome are presented in several paragraphs. First, clinical characteristics of families with USH1d or DFNB12 are described. It was shown that the truncating mutations in *CDH23* causing USH1d, lead to significantly more severe HI than the missense mutations that cause DFNB12. In USH1d, the cadherin 23 molecules are probably absent or not functional and the stereocilia do not develop properly. Almost all the missense mutations identified in DFNB12 families affect the highly conserved  $\text{Ca}^{2+}$ -binding sites in the extracellular cadherin domains.  $\text{Ca}^{2+}$  is necessary for the rigid elongated structure of the cadherin molecule and enables homophilic lateral interactions.<sup>1</sup> Abnormal development of the cochlear and vestibular stereocilia causes profound HI and vestibular areflexia in Usher syndrome type I. Recently, it was shown that a number of Usher syndrome type I proteins are likely to form a complex that shapes the stereocilia in the inner ear.<sup>2,3</sup> It can be hypothesised that similar interactions in a functional complex may be involved in the pathogenetic mechanism of RP, however, at the moment this is still not proven. Future research should therefore not only focus on family studies to identify new Usher syndrome type I genes, but also on the interactions of the currently identified Usher syndrome type I proteins in the stereocilia and the

retina in order to identify candidate genes. It can be hypothesised whether a similar complex of extracellular matrix proteins, encoded by *USH2* genes, is involved in the pathogenetic mechanism underlying Usher syndrome type II.

Usher syndrome type I is characterised by severe to profound deafness, whereas Usher syndrome type II shows moderate to severe HI. Usher syndrome type III is typically characterised by progressive HI. The present study has shown that patients with *USH2a* have progressive HI of about 0.5 dB/year. Reisser et al.<sup>4</sup> reported on clinically classified Usher syndrome type II patients with no mention of the related genotype and they concluded that there was no progression of HI in these patients. Nowadays however, analysis of pure tone audiograms should preferably be performed on patients with a confirmed genotype instead of on clinically classified patients.<sup>5</sup> To further evaluate the HI in the genetic subtypes of Usher syndrome type II and type III, the number of clinically well examined patients with a confirmed genotype needs to be increased.

Visual impairment is the most prominent handicap in most patients with Usher syndrome. It is assumed that Usher syndrome type I patients have more visual impairment than Usher syndrome type II patients and several clinical reports have emphasised confirmatory findings.<sup>6-8</sup> The present study has shown that in cross-sectional analysis there is no significant difference between the functional vision scores in *USH1b* and *USH2a*. However, longitudinal analysis in *USH2a* patients clearly showed a later onset of deterioration at a higher rate. Future studies, preferably performed in a multicentre approach on a large number of clinically well-examined Usher syndrome patients with a molecular diagnosis, will reveal whether or not there is a clear difference between *USH1b* and *USH2a*. Such studies may eventually also reveal differences in phenotype between different types of mutations in the same gene.

In the present study we also performed mutation analysis of the *USH2A* gene. In 63% (n=50) of 79 Dutch families, of which all patients (n=108) were clinically classified as Usher syndrome type II, we identified 1 or 2 mutations. In 29% (n=23) of the families both mutations were identified, whereas in 34% (n=27) the mutation in only one allele was found. It is hypothesised that the currently unknown *USH2A* mutations are likely to be intron mutations that affect splicing, represent mutations in regulatory sequences or intragenic deletions that remain undetected with the methods used for mutation analysis. It could, however, also

be possible that there are mutations in as yet unidentified coding sequences. Ten different mutations, 3 of which are new, were found in the 79 families. Future research will be focused on these issues and it will be attempted to identify all *USH2A* mutations in the participating Usher syndrome type II families.

Nowadays, patients with Usher syndrome are much more aware of the natural course of their disease than they were several decades ago. With the growing knowledge of genotype and phenotype, the Usher syndrome patients can receive information that is more specific for their own genetic subtype. To date, already several exons of *USH2A* and *MYO7A* are routinely examined by the DNA diagnostics laboratory in Nijmegen. To facilitate fast and successful mutation analysis for Usher syndrome, the Nijmegen Otagenetic laboratory has in 2003 initiated the development of the first Usher syndrome micro-array. This Usher chip will be a cost-effective high-throughput testing method, which soon will favour access to DNA-diagnostic facilities for most Usher syndrome patients worldwide.

## GENETIC AND CLINICAL FEATURES OF WOLFRAM SYNDROME

In **Chapter 4** the results of audiovestibular examinations in Wolfram syndrome patients are described. One of the most remarkable findings is that of the Wolfram syndrome patients with inactivating *WFS1* mutations, the female patients had significantly more HI than the male patients, even within the same sibship. The *WFS1* gene encodes wolframin, which is a transmembrane domain protein. Wolframin is located in the canalicular reticulum, a specified type of the ER, in different cell types in the inner ear.<sup>9</sup> Recently, it was shown that wolframin is involved in the homeostasis of intracellular  $Ca^{2+}$ .<sup>10</sup> The noticed gender difference in HI may be related to the involvement of sex hormones. In the next paragraphs a hypothesis of the function of wolframin is described, which suggests that nongenomic actions of estrogen are involved in intracellular  $Ca^{2+}$  homeostasis by wolframin.

Estrogen influences differentiation, growth and function of the female reproductive tract. These actions are performed by binding to nuclear estrogen receptors, which function as hormone-dependent transcription factors with an

important role in the endocrine signalling system.<sup>11</sup> Besides genomic actions, estrogen may also elicit nongenomic effects, which directly lead to activation of signal transduction pathways.<sup>12</sup> Binding of estrogen to nongenomic estrogen receptors in the plasma membrane directly results in an intracellular  $\text{Ca}^{2+}$  increase.<sup>13</sup> The rapidity of this increase is consistent with the activation of a cell surface receptor and is different from the conventional slow-acting nuclear estrogen receptors.  $\text{Ca}^{2+}$  is released from intracellular organelles, such as the endoplasmic reticulum (ER).  $\text{Ca}^{2+}$ -ATPase is located in the ER membrane and releases  $\text{Ca}^{2+}$ . Wolframin is also located in the ER membrane and is involved in intracellular  $\text{Ca}^{2+}$  homeostasis.<sup>10</sup> It may therefore be possible that nongenomic actions of estrogen may influence intracellular calcium homeostasis through wolframin.

This hypothesis is in line with findings reported in several other studies. Patients with Wolfram syndrome have progressive high-frequency HI and similar audiometric results have been reported for Turner syndrome patients.<sup>14</sup> Turner syndrome is caused by total or partial deletion of one X chromosome (X0) in all or in some cells. HI in Turner syndrome patients is less progressive and severe than seen in patients with Wolfram syndrome and 72% of the Turner syndrome patients older than 34 years have mid- and high-frequency HI.<sup>15</sup> Patients with Turner syndrome have estrogen deficiency, which requires long-term estrogen replacement therapy.<sup>16</sup> In addition, a recent study by Lee and Marcus<sup>17</sup> showed that estrogen decreases the secretion of  $\text{K}^{+}$  into the endolymph by inhibition of the  $\text{I}_{\text{Ks}}$  channels (KCNQ1/KCNE1) apical located in the marginal cells of the stria vascularis in the inner ear, through a nongenomic action mechanism. Decreased levels of estrogen thus affect inner ear ion homeostasis and causes mid- and high-frequency HI in Turner syndrome patients. Possibly, wolframin is involved in the same pathogenic mechanism that causes progressive mid- and high- frequency HI due to a disturbance of the inner ear homeostasis, regulated by estrogen.

Other studies showed that nongenomic actions of estrogen also may be involved in organs that are affected in Wolfram syndrome. A recent review by Garcia-Segura<sup>18</sup> has emphasised the role of estrogen in neuroprotection. Wolfram syndrome is a progressive neurodegenerative syndrome. It is also known that the ER  $\text{Ca}^{2+}$  ATPase inhibitor thapsigargin induces neuronal apoptosis, whereas the apoptosis is decreased by administration of estradiol and the phytoestrogen genistein.<sup>19</sup> It thus might well be possible that estrogen is required to maintain



normal neuronal function by regulation of the intracellular  $\text{Ca}^{2+}$  homeostasis. Besides that, estrogen is also involved in psychiatric disease such as Alzheimer's disease and schizophrenia.<sup>20</sup> Patients with Wolfram syndrome are also prone to the development of psychiatric diseases.

In addition, Wolfram syndrome patients develop hypothalamic diabetes insipidus due to a lack of vasopressin. Truncated wolframin thus affects the release of vasopressin. Two studies have reported that estrogen is involved in vasopressin release as well. One study reported gender differences in plasma vasopressin concentrations and suggested a modulating role for estrogen in vasopressin releasing neurons.<sup>21</sup> Another study demonstrated that estradiol inhibits the osmotically stimulated release of vasopressin.<sup>22</sup>

Male patients with Wolfram syndrome have primary gonadal atrophy and produce less amounts of testosterone than do normal male subjects. Truncated wolframin in male patients thus disturbs normal testosterone production in the Leydig cells of testis. Ciocca et al.<sup>23</sup> identified an estrogen-regulated protein in the cytoplasmic matrix, close to the cisternae of the rough and smooth ER of Leydig cells. This estrogen-regulated protein possibly interacts with wolframin in the regulation of testosterone production.

The aforementioned data are compatible with our hypothesis. However, future research has to reveal whether there indeed is a link between wolframin and the estrogen-regulated calcium signalling pathways.

## CLINICAL FEATURES OF DFNA6/14

In **Chapter 5**, the audiovestibular analyses of two families with low-frequency HI type DFNA6/14 are described. DFNA6/14 is caused by missense mutations in the *WFS1* gene. It is known that DFNA6/14 can easily be diagnosed when there is a medical history of autosomal dominantly inherited low-frequency HI.<sup>24</sup> In most of these cases, mutations in the *WFS1* gene will be found. Another locus of nonsyndromic autosomal dominantly inherited low-frequency HI is DFNA1, which has been identified in a large Costa Rican family.<sup>25</sup> It is still unclear why DFNA6/14 mutations mainly affect the low frequencies, whereas the high frequencies are affected in Wolfram syndrome. Although previous studies

suggested that DFNA6/14 is characterised by stable hearing loss, the present study has shown that the affected family members in two DFNA6/14 families do have progressive sensorineural HI. There was no substantial difference in pure tone audiogram findings between the Dutch III and Dutch IV family, although the 2 kHz threshold appeared to be more affected in the Dutch III family. The evaluation of speech recognition scores showed significantly different scores for the performance-impairment plot, whereas the performance-age plot showed similar scores for both families. The performance-impairment plot difference may be related to the higher threshold values monitored in the 2 kHz frequency in the Dutch III family.

## FUTURE PERSPECTIVES IN HEREDITARY DEAFBLINDNESS

Nowadays, many patients with congenital profound HI receive a cochlear implant at young age. These patients clearly benefit from their cochlear implant. Although this is a controversial issue, cochlear implantation may also be useful when applied at higher ages. Especially patients with an additional visual handicap, like Usher syndrome type I patients, might benefit from implantation. In these patients it may subserve as a signalling function when they have lost most of their visual abilities. Future research has to reveal whether or not this is really useful and satisfactory.

An interesting development in the treatment of visual impairment due to retinal pathology is the development of retinal prostheses, which is inspired by the good results of the cochlear implants. Two interesting reviews on this subject were written by Margalit et al.<sup>26</sup> and by Zrenner.<sup>27</sup> Currently, 2 types of retinal implants that can be used in RP patients are being developed. The *epiretinal implant* can be introduced through the vitreous cavity and is attached to the inner retinal surface and electronically stimulates the inner retina. Recently, Humayun et al.<sup>28</sup> reported the first details of testing with this type of implant in a blind RP patient. After implantation, the subject was able to see perceptions of light and by using a camera the subject was able to detect the presence of ambient light, to detect motion, and to recognise simple shapes.<sup>28</sup> The *subretinal implant* can be placed in the potential space between the outer retinal layer and the retinal pigment epithelium and stimulates the outer retina. A lot of work still has to be done to safely implant large patients groups with RP and to date, the retinal implant

devices are being applied only as a research effort. Although still little is “seen” with the retinal implants, RP patients in the future may benefit as much from their retinal implant as do cochlear implant patients.<sup>26,27</sup>

Future research may reveal the function of specific Usher syndrome proteins in the inner ear and retina. This would be useful for the development of new treatment modalities. Gene therapy may be one of these new therapies. Recent advances in transgenic and gene targeting technologies in mice that offer new opportunities to manipulate the expression of genes and study their role *in vivo* will support the development of gene therapy.<sup>29</sup> The first steps towards application of cochlear gene therapy have been made and seem promising. Viral and non-viral vectors have been shown to be able to introduce and express exogenous genes in the peripheral auditory system.<sup>30</sup> Not only cochlear gene therapies, but also retinal gene therapies are currently being developed and are ahead of the trials in the inner ear. Recently, some success in the delivery of potentially therapeutic genes to retinal tissues in case of recessive disease involving retinal degeneration was reported for experimental animal models.<sup>31-34</sup> However, dominantly inherited retinal disorders show mutational heterogeneity, and it is challenging to see whether it is possible to develop mutation-independent therapeutic approaches that target the primary or secondary effects of the involved mutations. One of the promising concepts in this field is the mutation-independent suppression utilising the degeneracy of the genetic code. In this concept, a ribozyme is designed to cleave a target transcript at a degenerate site. In parallel, a replacement gene is supplied that encodes wild-type protein but has been subtly modified at degenerate sites to such an extent that the ribozyme cannot cleave transcripts from the replacement gene.<sup>35</sup> Other strategies are the modulation of secondary effects associated with disease pathology and the delivery of appropriate neurotrophic factors to photoreceptor cells in an attempt to improve the survival rates of these specialised neurons.<sup>35</sup>

In addition, stem cell therapy is being developed as another type of treatment. A recent study<sup>36</sup> identified cells that display characteristic features of stem cells in the adult utricular sensory epithelium. It is known that damaged vestibular organs can, to some extent, generate new hair cells. These inner ear stem cells have the capacity of self-renewal, are pluripotent and can give rise to a variety of cell types *in vivo* and *in vitro*, including cells representative for ectodermal, endodermal and mesodermal lineages. This finding implies a possible use of such cells for the

replacement of lost inner ear sensory cells.<sup>36</sup> Another recent study<sup>37</sup> has shown that it is possible to regenerate hair cells in mature mammalian inner ears by the application of adenoviral mediated overexpression of *Hath1*, a human *atonal* homolog. This study concluded that local adenoviral gene therapy in the inner ear may be a potential approach to treat hearing and balance disorders. Similar studies are being performed on retinal degenerations and dystrophies. One of those studies<sup>38</sup> recently showed that it is possible to partially differentiate adult CD90+ marrow stromal cells into photoreceptors in vitro and in vivo. This may provide a promising therapeutic strategy for the treatment of some forms of hereditary retinal degenerations.<sup>38</sup>

## REFERENCES

- 1 de Brouwer APM, Pennings RJE, Roeters M, Van Hauwe P, Astuto LM, Hoefsloot LH, Huygen PLM, van den Helm B, Deutman AF, Bork JM, Kimberling WJ, Cremers FPM, Cremers CWRJ, Kremer H Mutations in the calcium-binding motifs of CDH23 and the 35delG mutation in *GJB2* cause hearing loss in one family *Hum Genet* 2003,112 156-163
- 2 Boeda B, El-Amraoui A, Bahloul A, Goodyear R, Daviet L, Blanchard S, Perfettini I, Fath KR, Shorte S, Reiners J, Houdusse A, Legrain P, Wolftrum U, Richardson G, Petit C Myosin VIIa, harmonin and cadherin 23, three Usher I gene products that cooperate to shape the sensory hair cell bundle *EMBO* 2002,21 6689-6699
- 3 Weil D, El-Amraoui A, Masmoudi S, Mustapha M, Kikkawa Y, Laine S, Delmaghani S, Adato A, Nadifi S, Zina ZB, Hamel C, Gal A, Ayadi H, Yonekawa H, Petit C Usher syndrome type I G (USH1G) is caused by mutations in the gene encoding SANS, a protein that associates with the USH1C protein, harmonin *Hum Mol Genet* 2003,12 463-471
- 4 Reisser CF, Kimberling WJ, Otterstedde CR Hearing loss in Usher syndrome type II is nonprogressive *Ann Otol Rhinol Laryngol* 2002,111 1108-1111
- 5 Pennings RJE, Huygen PLM, Cremers CWRJ Letter to the editor Progressive or nonprogressive hearing loss in Usher syndrome type II *Ann Otol Rhinol Laryngol* 2003,112 825
- 6 Fishman GA, Kumar A, Joseph ME, Torok N, Anderson RJ (1983) Usher's syndrome Ophthalmic and neuro-otologic findings suggesting genetic heterogeneity *Arch Ophthalmol* 101 1367-1374
- 7 Piazza L, Fishman GA, Farber M, Derlacki D, Anderson RJ (1986) Visual acuity loss in patients with Usher's syndrome *Arch Ophthalmol* 104 1336-1339
- 8 Edwards A, Fishman GA, Anderson RJ, Grover S, Derlacki DJ (1998) Visual acuity and visual field impairment in Usher syndrome *Arch Ophthalmol* 116 165-168
- 9 Cryns K, Thys S, Van Laer L, Oka Y, Pfister M, Van Nassauw L, Smith RJH, Timmermans JP, Van Camp G The WFS1 gene, responsible for low frequency sensorineural hearing loss and Wolfram syndrome, is expressed in a variety of inner ear cells *Histochem Cell Biol* 2003,119 247-256
- 10 Osman AA, Saito M, Makepeace C, Permutt MA, Schlesinger P, Mueckler M Wolframin expression induces novel ion channel activity in endoplasmic reticulum membranes and increases intracellular calcium *J Biol Chem* 2003,278 52755-52762
- 11 Nilsson S, Gustafsson JA Estrogen receptor action *Crit Rev Eukaryot Gene Expr* 2002,12 237-257
- 12 Nilsson S, Makela S, Treuter E, Tujague M, Thomsen J, Andersson G, Enmark E, Pettersson K, Warner M, Gustafsson JA Mechanisms of estrogen action *Phys Rev* 2001,81 1535-1565
- 13 Morley P, Whitfiels JF, vanderHeyden BC, Tsang BK, Schwartz J-L A new, nongenomic estrogen action the rapid release of intracellular calcium *Endocrinology* 1992,131-1305-1312
- 14 Gungör N, Böke B, Belgin E, Tunçbilek E High-frequency hearing loss in Ullrich-Turner syndrome *Eur J Pediatr* 2000,159 740-744
- 15 Barrenas M-L, Nylen O, Hanson C The influence of karyotype on the auncle, otitis media and hearing in Turener syndrome *Hear Res* 199,138 163-170

- 16 Elsheikh M, Dunger DB, Conway GS, Wass JAH Turner's syndrome in adulthood. *Endocrine Rev* 2002;23:120-140
- 17 Lee JH, Marcus DC Estrogen acutely inhibits ion transport by isolated stria vascularis. *Hear Res* 2001;158 123-130.
- 18 Garcia-Segura LM, Azcoitia I, DonCarlos LL Neuroprotection by estradiol. *Prog Neurobiol* 2001;63 29-60
- 19 Linford NJ, Dorsa DM 17 $\beta$ -Estradiol and the phytoestrogen genistein attenuate neuronal apoptosis induced by the endoplasmic reticulum calcium-ATPase inhibitor thapsigargin *Steroids* 2002;67 1029-1040.
- 20 Huber TJ, Rollnik J, Wilhelms J, von zur Muhlen A, Emrich HM, Schneider U Estradiol levels in psychotic disorders. *Psychoneuroendocrinol* 2001;26 27-35
- 21 Somponpun S, Sladek CD Role of estrogen receptor-beta in regulation of vasopressin and oxytocin release *in vitro* *Endocrinology* 2002;143 289-2904
- 22 Swenson KL, Badre SE, Morsette DJ, Sladek CD N-methyl-D-aspartic acid stimulation of vasopressin release: role in osmotic regulation and modulation by gonadal steroids *J Neuroendocrinol* 1998;10:679-685
- 23 Ciocca DR, Winters CA, Dufau ML. Expression of an estrogen-regulated protein in rat testis Leydig cells. *J Steroid Biochem* 1986;24 219-229
- 24 Cryns K, Pfister M, Pennings RJE, Bom SJH, Flothmann K, Caethoven G, Kremer H, Schatteman I, Koln KA, Tóth T, Kupka S, Blin N, Nürnberg P, Thiele H, van de Heyning PH, Reardon W, Stephens D, Cremers CWRJ, Smith RJH, Van Camp G. Mutations in the WFS1 gene that cause low-frequency sensorineural hearing loss are small non-inactivating mutations *Hum Genet* 2002;110:389-394.
- 25 Lynch ED, Lee MK, Morrow JE, Welsh PL, León PE, King MC. Nonsyndromic deafness DFNA1 associated with mutation of a human homolog of the *Drosophila* gene *diaphanous* *Science* 1997;278:1315-1318.
- 26 Margalit E, Maia M, Weiland JD, Greenberg RJ, Fujii GY, Torres G, Piyathaisere DV, O'Hearn TM, Liu W, Lazzi G, Dagnelie G, Scribner DA, de Juan Jr E, Humayun MS. Retinal prosthesis for the blind. *Surv Ophthalmol* 2002;47:335-356.
- 27 Zrenner E. Will retinal implants restore vision? *Science* 2002;295:1022-1025
- 28 Humayun MS, Weiland JD, Fujii GY, Greenberg R, Willamson R, Little J, Mech B, Cimmarusti V, Van Boemel G, Dagnelie G, de Juan Jr E. Visual perception in a blind subject with a chronic microelectronic retinal prosthesis *Vis Res* 2003;43 2573-2581
- 29 Zuo J Transgenic and gene targeting studies of hair cell function in mouse inner ear. *J Neurobiol* 2002;53 286-305.
- 30 Steel KP New interventions in hearing impairment *BMJ* 2000;320 622-625
- 31 Bennett J, Tanabe T, Sun D, Zeng Y, Kjeldbye H, Gouras P, Maguire AM. Photoreceptor cell rescue in retinal degeneration (rd) mice by *in vivo* gene therapy *Nature Med* 1996;2:649-654
- 32 Takahashi M, Miyoshu H, Verma IM, Gage FH Rescue from photoreceptor degeneration in the rd mouse by human immunodeficiency virus vector-mediated gene transfer. *J Virol* 1999;73:7812-7816
- 33 Alí RR, Sarra GM, Stephens C, Alwis MD, Bainbridge JW, Munro PM, Fauser S, Reichel MB, Kinnon C, Hunt DM, Bhattacharya SS, Trasher AJ. Restoration of photoreceptor ultrastructure and function in retinal degeneration slow mice by gene therapy. *Nat Genet* 2000;25:306-310.
- 34 Acland GM, Aguirre GD, Ray J, Zhang Q, Aleman TS, Cideciyan AV, Pearce-Kelling SE, Anand V, Zeng Y, Maguire AM, Jacobson SG, Hauswirth WW, Bennett J. Gene therapy restores vision in a canine model of childhood blindness. *Nat Genet* 2001;28:92-95
- 35 Farrar GJ, Kenna PF, Humphries P On the genetics of retinitis pigmentosa and on mutation-independent approaches to therapeutic intervention. *EMBO* 2002;21:857-864
- 36 Li H, Liu H, Heller S Pluripotent stem cells from the adult mouse inner ear. *Nat Med.* 2003;9 1293-1299.
- 37 Shou J, Zheng JL, Gao WQ Robust generation of new hair cells in the mature mammalian inner ear by adenoviral expression of Hath1. *Mol Cell Neurosci* 2003;23 169-179
- 38 Kicic A, Shen WY, Wilson AS, Constable IJ, Robertson T, Rakoczy PE. Differentiation of marrow stromal cells into photoreceptors in the rat eye *J Neurosci* 2003;23 7742-7749.

# CHAPTER 7

## SUMMARY AND CONCLUSIONS



In this thesis, clinical and genetic aspects of hereditary types of hearing and visual impairment are delineated. This Ph.D. project forms part of the Nijmegen hereditary HI studies.

## SUMMARY

**Chapter 1** is a general introduction to the subject of this thesis. The first part of this chapter focuses on the historical, clinical and genetic characteristics of Usher syndrome. Usher syndrome is the most common deafblindness syndrome with a prevalence of about 3.5-6.2 per 100,000 individuals. It is believed to account for more than 50% of all deafblindness cases. It shows autosomal recessive inheritance and is classified into 3 different types on the basis of audiovestibular features. Not only is there clinical heterogeneity, but also genetic heterogeneity. Linkage studies have identified 11 loci and 7 corresponding genes were identified on the basis of positional cloning. At least 7 loci (USH1A-USH1G) and 5 corresponding genes (*MYO7A*, *USH1C*, *CDH23*, *PCDH15*, *SANS*) have been cloned so far for USH1. Patients with USH1 show congenital profound HI, vestibular areflexia and progressive RP. Three loci (USH2A-USH2C) and 1 gene (*USH2A*) have so far been cloned for USH2. The USH2 patients show downsloping moderate-to-severe high-frequency HI, intact vestibular responses and progressive RP. Worldwide, USH3 is rare (2% of all Usher syndrome cases), however, it is relatively common in Finland (40%). It typically shows progressive HI, variable vestibular responses and progressive RP. One locus (USH3) and gene (*USH3*) have been reported for this specific type of Usher syndrome.

The second part of **Chapter 1** is a general introduction to Wolfram syndrome, which is a rare deafblindness syndrome (1:770,000 individuals in the UK). The acronym DIDMOAD covers the main features of the syndrome, Diabetes Insipidus, Diabetes Mellitus, Optic Atrophy and Deafness. Other associated features are urological abnormalities, neuropsychiatric abnormalities and hypogonadism. Patients with Wolfram syndrome are born without any symptoms. Progression of this neurodegenerative disease gradually leads to an increasing loss of organ functions. These patients die at young age; the median age at death is about 30 years (25-49 years). Wolfram syndrome shows autosomal recessive inheritance and is caused by mutations in the *WFS1* gene.



The third part of **Chapter 1** concerns the molecular genetics of sensorineural HI. Many centres worldwide perform genetic studies in HI and the knowledge of the genes and function of the encoded proteins in the inner ear has emerged enormously in the past ten years. The currently known genes and the diseases they are causative for are presented. Based on their function, the genes are categorised into the following groups: 1. Hair cell structure and function, 2. Ion homeostasis and K<sup>+</sup> recycling, 3. Transcription factors, 4. Extracellular matrix proteins, 5. Receptors and ligands, 6. Cellular trafficking proteins, 7. Genes whose function is currently unknown.

The last part of **Chapter 1** is a review of progressive phenotypes in nonsyndromic autosomal dominant HI. It focuses on the variability in phenotypic features as presented by the analysis of audiometric profiles (ARTA) and of speech recognition scores of DFNA1, DFNA2, DFNA4, DFNA5, DFNA6/14, DFNA7, DFNA9, DFNA10, DFNA15, DFNA16, DFNA17, DFNA20/26 and DFNA21.

**Chapter 2** describes methods to analyse progressive HI traits. Cross-sectional and longitudinal regression analyses of pure tone thresholds are used to construct Age Related Typical Audiograms (ARTA) that present the data in an audiogram-like format. Where possible, these data cover decade steps in age. An additional newly developed tool is the Threshold Features Array (TFA). This one-dimensional array is used for statistical tests involving different forms of HI. In the ongoing Nijmegen family studies of progressive nonsyndromic HI, the ARTA and TFA are used where possible for guiding genetic analyses.

**Chapter 3** is dedicated to Usher syndrome. This part of the study is the continuation of two previous Usher syndrome PhD projects by Annelies van Aarem and Mariette Wagenaar. In six parts of this chapter studies on the clinical and genetic features of this syndrome are described.

The first part of this chapter presents the phenotypic features of Usher syndrome type Id (3 families, 6 patients) and DFNB12 (1 family, 4 patients), both caused by mutations in the *CDH23* gene. The USH1d patients had significantly worse HI than the DFNB12 patients. Missense mutations in *CDH23* caused DFNB12 and these patients had normal retinal and vestibular function. The USH1d patients all had splice site mutations in *CDH23* that lead to truncation of the protein. Besides profound HI, these patients also have vestibular areflexia and RP. In one DFNB12

patient abnormal flecks in the posterior pole of the eye could be seen. Another DFNB12 patient had increased reflexes and minifolds of the internal limiting membrane in the macular area on funduscopy.

In part 3.2 the deterioration of visual function in patients with Usher syndrome type Ib and Usher syndrome type IIa is addressed. The visual functions of 19 USH1b and 40 USH2a patients, identified by at least 1 mutation in *MYO7A* and *USH2A* respectively, were evaluated by measuring the best-corrected visual acuity and using Goldmann perimetry to assess the visual fields. The functional acuity score (FAS), functional field score (FFS) and the functional vision score (FVS) were evaluated according to the descriptions of the American Medical Association Guides for the Evaluation of Permanent Impairment. Cross-sectional analyses revealed no significant difference in the deterioration of any of the functional scores with advancing age between USH1b and USH2a. The FAS, FFS and FVS deteriorated by on average 0.7%, 1.0% and 1.5% per year, respectively. The mean onset age, estimated on the basis of longitudinal analyses in the USH2a patients, was 37, 18 and 14 years for FAS, FFS and FVS, respectively. The estimates of the rate of deterioration were higher than those found in cross-sectional analyses (FAS: 5.2%/y, FFS: 2.5%/y, FVS: 2.4%/y).

The third part of this chapter describes the audiometric profile of 36 patients with Usher syndrome type IIa, identified by at least one pathogenic mutation in the *USH2A* gene. It was shown that USH2a patients in general have a moderate to severe downsloping audiogram with threshold progression of about 0.5 dB/year. In 30 patients speech recognition scores were evaluated and it appeared that they started to deteriorate from 38 years of age onwards (90% recognition) at a rate of 0.4% per year. The 90% recognition level was attained at 69 dB hearing level and deteriorated with increasing level of HI by 0.6%/dB HL.

In part 3.4, the vestibular function in relation to deteriorating visual function in 29 Usher syndrome type IIa patients, all identified by at least one pathogenic mutation in the *USH2A* gene, was analysed. The optokinetic nystagmus (OKN) response level and the vestibulo-ocular reflex (VOR) were analysed. Remarkably, the VOR was intact but seldom normal. The VOR gain and time constant (T) were more often significantly higher or lower than could have been expected on the basis of chance alone. The OKN response level and the functional vision scores all decreased significantly, whereas T increased significantly with advancing age.

The fifth part of this chapter describes the results of *USH2A* mutation analysis in 79 Dutch families with Usher syndrome type II. In 63% of the families at least 1 pathogenic *USH2A* mutation was detected. In 23 families (29%) the mutations in both alleles were identified and in 27 families (34%) the mutation in only one allele was identified. It is hypothesised that intron mutations that affect splicing, mutations in regulatory sequences or deletions of parts of the gene account for the remaining unidentified genetic defects. Assuming that all *USH2* patients with 1 mutated *USH2A* allele are in fact *USH2a* patients, it is estimated that 23% of the Dutch *USH2* patients have mutations in a different *USH2* gene. Three new pathogenic mutations (R317R, Q748X and Q1468X) are described to cause *USH2a*. A total of 10 different mutations, detected in 6 exons, are found to be causative for *USH2a* in the Netherlands. Typical Dutch *USH2A* mutations are C419F, W409X and R317R presently identified in 16, 7 and 4 alleles of 15, 6 and 4 families, respectively. It is very likely that the C419F mutation has an ancestral origin on the basis of a core haplotype deduced from 10 single nucleotide polymorphisms, whereas this was not conclusively possible for the W409X and R317R mutations.

The last part of this chapter describes the clinical and genetic features of the first *USH3* family identified in the Netherlands. Two patients from this family were found to be homozygous for a new *USH3* mutation (149-152delCAGG + ins TGTC CAAT). One individual had profound HI with normal vesibular function and retinitis punctata albescens. The other individual also had HI, but with well-developed speech, vestibular areflexia and retinitis pigmentosa sine pigmento. On the basis of these findings, it was concluded that Usher syndrome type III can easily be misdiagnosed as Usher syndrome type I or II.

**Chapter 4** focuses on the audiovestibular presentation of Wolfram syndrome. This study included 11 Wolfram syndrome patients (4 male, 7 female) and 17 related heterozygous carriers. Patients and carriers were identified by pathogenic mutations in the Wolfram syndrome 1 gene (*WFS1*). None of the carriers had sensorineural hearing loss. The patients in general showed a downsloping audiogram and progressive HI. Two patients with missense mutations in *WFS1* had normal hearing for their age and relatively mild Wolfram syndrome symptoms. These 2 patients were excluded from further analyses. The remaining 9 patients all had inactivating mutations in the *WFS1* gene and it was shown that the female patients had significantly more severe HI than the male patients. The

---

female patients showed progression of HI by 1.5-2.0 dB HL per year for the low frequencies and 4.0-4.5 dB HL per year for the mid and high frequencies. Speech recognition started to deteriorate (90% score) at age 21 at a HI level of 78 dB HL. The deterioration rate was 4.0% per year and the deterioration gradient was 1.4%/dB HL. One of the 6 patients examined had vestibular areflexia.

**Chapter 5** describes the audiometric profile of low-frequency HI (DFNA6/14) occurring in two families (Dutch III, 9 patients and Dutch IV, 4 patients). Heterozygous mutations in the *WFS1* gene were found to cause this type of autosomal dominantly inherited nonsyndromic sensorineural HI. Progression of HI beyond presbycusis was found in affected persons from both families. The annual threshold deterioration was between 0.6 and 1 dB at all frequencies. Remarkably, the speech recognition scores in family Dutch III showed significantly more deterioration at increasing levels of HI than those reported for family Dutch IV.

## CONCLUSIONS

This Ph.D. project has succeeded to report on new clinical and molecular genetic features of Usher syndrome, Wolfram syndrome and DFNA6/14. In addition, methods to analyse progression of HI were developed. Several interesting conclusions can be drawn from this study. The study on HI in USH2a patients showed that these patients have progression of HI by about 0.5 dB/y. In general, it was previously thought that Usher syndrome type II patients had no progression of HI other than presbycusis. In addition, it was shown that the visual impairment in 19 USH1b patients did not statistically differ in cross-sectional analysis from that of 40 USH2a patients. However, longitudinal analysis of visual functions in the USH2a patient group revealed that the deterioration may have developed at a more advanced age and that the rate of deterioration was much higher in USH2a than was reported in the cross-sectional analysis. The visual impairment in USH2a and USH1b was quite similar by age 40-50 years. It was also shown that the USH2a patients seldom showed normal vestibular responses and that the OKN response level decreased significantly whereas the time constant T increased significantly with advancing age. Another remarkable finding was the gender difference in HI in Wolfram syndrome patients, who had been identified by inactivating *WFS1* mutations.

The importance of performing studies such as the present one is best illustrated by the enormous advance in knowledge that has been made over the past decade. Ten years ago only a few deafness genes had been cloned and only little was known about the function of their protein products within the inner ear. Without elaborate family studies, this type of knowledge would never have developed so rapidly. By performing linkage studies on families, showing syndromic or nonsyndromic HI, new genes can be identified and their role and function in the inner ear can be studied. The enormous development in knowledge of inner ear genes is best illustrated in the third part of the introduction (1.3), which is focused on the molecular genetics of sensorineural HI. Certainly now that most of the more prevalent genes have been identified, it is crucial to perform thorough analyses of the clinical features seen within these families to optimally assist the molecular geneticists.

Studies like the present one are also important for patients and their relatives because they can be informed more precisely about their disease. Certainly nowadays, when patients are increasingly asking for specific information about their disease, we should be able to respond properly. Mutation analysis has become available and provides a more exact diagnosis. To remain cost-effective, it is imperative that a correct clinical diagnosis accompanies the request for mutation analysis. Genotype-phenotype correlation studies such as those performed in this thesis are necessary to obtain correct clinical diagnoses. When mutation analysis is available, it is also possible to evaluate carriership within affected families and even prenatal DNA diagnostics can be offered. Such new opportunities favour the quality of genetic counseling.

The attitude of affected individuals towards the type of studies and their willingness to participate clearly demonstrate the socio-emotional importance for these patients. Hopefully, this and future projects will finally result in proper treatment of this and many other types of hereditary syndromic and nonsyndromic HI.

In dit proefschrift worden klinische en genetische aspecten van erfelijke slechthorendheid en slechthorendheid beschouwd. Dit promotieproject is onderdeel van de Nijmegen erfelijke slechthorendheidsstudies.

## SAMENVATTING

In **Hoofdstuk 1** wordt een algemene inleiding over het onderwerp van dit proefschrift gegeven. Het eerste deel van dit hoofdstuk beschrijft de historische achtergronden en de klinische en genetische kenmerken van Usher syndroom. Usher syndroom is het meest voorkomende doofblindheidssyndroom met een prevalentie van ongeveer 3,5-6,2 per 100.000 personen. Er wordt geschat dat het meer dan 50% van alle doofblindheid veroorzaakt. Het erft autosomaal recessief over en wordt ingedeeld in 3 verschillende typen op grond van audiovestibulaire kenmerken. Usher syndroom is zowel klinisch als genetisch heterogeen. Koppelingsstudies hebben 11 loci en 7 corresponderende genen, waarin mutaties gevonden worden die het syndroom veroorzaken, geïdentificeerd. Voor Usher syndroom type I zijn er momenteel 7 chromosomale loci (USH1A-USH1G) en 5 genen (*MYO7A*, *USH1C*, *CDH23*, *PCDH15*, *SANS*) bekend. Patiënten met USH1 zijn vanaf hun geboorte volledig doof, vertonen vestibulaire areflexie en ontwikkelen progressieve RP. Voor USH2 zijn er momenteel 3 chromosomale loci (USH2A-USH2C) en 1 corresponderend gen (*USH2A*) bekend. USH2 wordt klinisch gekenmerkt door een matig ernstig gehoorverlies in de hoge frequenties, intacte vestibulaire reflexen en progressieve RP. USH3 is wereldwijd zeldzaam (2% van alle Usher syndroom patiënten), maar komt veelvuldig voor in Finland (40%). USH3 wordt gekenmerkt door evidente progressie van het gehoorverlies, aanwezige maar variabele vestibulaire reflexen en progressieve RP. Het USH3 locus en het bijbehorende gen (*USH3*) zijn gevonden en voornamelijk is dit het enige locus voor dit type Usher syndroom.

Het tweede deel van **Hoofdstuk 1** bevat een algemene inleiding van het Wolfram syndroom, een zeldzaam doofblindheidssyndroom (1 op de 770.000 personen in Groot-Brittannië). Een acroniem voor dit syndroom is DIDMOAD, vernoemd naar de belangrijkste kenmerken van het syndroom: Diabetes Insipidus, Diabetes Mellitus, Opticus Atrofie en Doofheid (slechthorendheid). Andere optredende kenmerken zijn urologische afwijkingen, neuropsychiatrische stoornissen en hypogonadisme. Patiënten met het Wolfram syndroom worden gezond geboren

zonder enige symptomen. Gedurende hun leven zorgt de progressie van deze neurodegeneratieve aandoening ervoor dat steeds meer organen problemen gaan vertonen. Deze patiënten worden niet oud en de mediane leeftijd bij overlijden is ongeveer 30 jaar (25-49 jaar). Dit syndroom erft autosomaal recessief over en wordt veroorzaakt door mutaties in het *WFS1* gen.

Het derde deel van **Hoofdstuk 1** beschrijft de huidige kennis van de moleculaire genetica van erfelijke perceptieve slechthorendheid. Meerdere centra in de wereld verrichten genetische studies naar erfelijke slechthorendheid en de kennis van genen en de oorfunctie van de door deze genen gecodeerde eiwitten in het binnenoor is enorm toegenomen in de afgelopen tien jaar. De momenteel bekende genen en aanverwante syndromale en niet-syndromale slechthorendheidsbeelden worden in dit deel van het hoofdstuk gepresenteerd en ingedeeld naar de betrokken functies in het binnenoor. De genen worden beschreven in de volgende categorieën: 1. Haarcelfunctie/mechanotransductie, 2. Ionenhomeostase en  $K^+$  recycling, 3. Transcriptiefactoren, 4. Extracellulaire matrix eiwitten, 5. Receptoren en liganden, 6. Eiwitten betrokken bij cellulair transport, 7. Genen met een momenteel nog onbekende functie.

Het laatste deel van **Hoofdstuk 1** is een review betreffende autosomaal dominant overervende progressieve nietsyndromale slechthorendheidsbeelden. De fenotypische kenmerken worden beschreven met behulp van leeftijdsgerelateerde audiogrammen (ARTA) en analyses van spraakverstaanbaarheidsscores voor de volgende beelden: DFNA1, DFBA2, DFNA4, DFNA5, DFNA6/14, DFNA7, DFNA9, DFNA10, DFNA15, DFNA16, DFNA17, DFNA20/26 en DFNA21.

**Hoofdstuk 2** beschrijft de statistische methoden die gebruikt worden om de fenotypes van progressieve erfelijke slechthorendheid te analyseren. Cross-sectionele en longitudinale regressie-analyse van de gehoordrempels ten opzichte van de leeftijd worden gemaakt om een leeftijdsgerelateerd audiogram (Age Related Typical Audiograms: ARTA) af te leiden. De ARTA tonen de progressie van het gehoorverlies in een audiogram-lay out waarbij de data, indien mogelijk, worden weergegeven in leeftijdsdecennia. Een nieuw ontwikkelde methode is de "drempelkenmerkenvector" (Threshold Features Array: TFA). Deze ééndimensionale vector wordt gebruikt om verschillende erfelijke slechthorendheidsbeelden statistisch tegen elkaar te toetsen. De ARTA en de TFA die afgeleid worden voor een onderzochte familie worden gebruikt voor het

maken van strategische keuzes om primair mutatie-analyse van een gen met een bekend en gelijkend phenotype te verrichten of juist te kiezen voor een genkoppelingsstudie.

**Hoofdstuk 3** van dit proefschrift is gewijd aan het Usher syndroom. Dit hoofdstuk sluit aan bij de twee eerdere proefschriften die door Annelies van Aarem en Mariette Wagenaar over dit syndroom zijn geschreven. In zes onderdelen wordt aandacht besteed aan de klinische en genetische kenmerken van dit syndroom.

Het eerste deel van dit hoofdstuk beschrijft de fenotypische kenmerken van Usher syndroom type Id (3 families, 6 patiënten) en DFNB12 (1 familie, 4 patiënten). Beide ziektebeelden worden veroorzaakt door mutaties in het *CDH23* gen. De USH1d patiënten hebben significant slechtere gehoordrempels dan de DFNB12 patiënten. Missense mutaties in het *CDH23* gen veroorzaken DFNB12 en deze patiënten hebben een normale retinale en vestibulaire functie. Alle USH1d patiënten hebben splice-site mutaties in het *CDH23* gen die leiden tot truncatie van het eiwit. Naast de congenitale totale doofheid hebben deze patiënten vestibulaire areflexie en RP. Bij één DFNB12 patiënt werden abnormale vlekken in de achterpool van het oog gezien.

In deel 3.2 wordt aandacht besteed aan de afname van de visus bij patiënten met Usher syndroom type Ib en Usher syndroom type IIa. Bij 19 USH1b en 40 USH2a patiënten werd de gecorrigeerde gezichtsscherpte (Snellen kaart) en de grootte van de gezichtsvelden (Goldmann perimetrie) opgemeten. Alle patiënten hebben tenminste 1 mutatie in respectievelijk het *MYO7A* of *USH2A* gen. De functionele gezichtsscherpte score (Functional Acuity Score, FAS), de functionele gezichtsveldscore (Functional Field Score, FFS) en de functionele visus score (Functional Vision Score, FVS) werden bepaald volgens de beschrijvingen van de American Medical Association Guides for the Evaluation of Permanent Impairment. Cross-sectionele analyse van de functionele scores in relatie tot de leeftijd liet geen significant verschil in verslechtering zien bij toenemende leeftijd tussen USH1b en USH2a. De FAS, FFS en FVS namen gemiddeld af met respectievelijk 0,7%, 1,0% en 1,5% per jaar. Longitudinale regressie-analyse van de scores van USH2a patiënten liet echter zien dat de afname van de scores weliswaar op een hogere leeftijd begon maar dat de mate van afname groter was. De gemiddelde beginleeftijden voor de FAS, FFS en FVS die zijn afgeleid via longitudinale analyses bij USH2a patiënten, waren respectievelijk 37, 18 en 14 jaar.



De schattingen van de jaarlijkse afname waren hoger dan gerapporteerd voor de cross-sectionele analyses (FAS: 5,2% per jaar, FFS: 2,5% per jaar, FVS: 2,4% per jaar).

Het derde deel van dit hoofdstuk beschrijft het audiometrisch profiel van 36 patiënten met USH2a. Alle patiënten hebben tenminste 1 mutatie in het *USH2A* gen. Uit dit onderzoek bleek dat USH2a patiënten in het algemeen een matig-ernstig gehoorverlies in de hoge frequenties hebben dat langzaam verergert met ongeveer 0,5 decibel per jaar. Bij 30 patiënten zijn de spraakherkenningscores geëvalueerd en is aangetoond dat vanaf de leeftijd van 38 jaar de spraakherkenningscores (<90%) verslechteren met een snelheid van 0,4% per jaar. De 90% spraakherkenningsdrempel wordt bereikt bij een gemiddelde drempel van 69 decibel en neemt dan af met 0,6% per decibel.

In deel 3.4 wordt de vestibulaire functie in relatie tot de afname van de visus beschreven voor 29 USH2a patiënten. Alle patiënten hebben tenminste 1 mutatie in het *USH2A* gen. De optokinetische nystagmus (OKN) respons en de vestibulo-oculaire reflex (VOR) zijn geanalyseerd. Het viel op dat de VOR intact was maar zelden normale waarden vertoonde. De VOR-gain en de VOR-tijdconstante (T) waren vaker significant hoger of lager dan op basis van kansberekening verwacht mag worden. De OKN-gain en de functionele visus scores namen beide significant af, terwijl T significant toenam met toenemende leeftijd.

Het vijfde deel van dit hoofdstuk beschrijft de resultaten van *USH2A* mutatie analyse verricht bij 79 Nederlandse families met Usher syndroom type II. Bij 63% van de families werden mutaties in het *USH2A* gen gevonden. Bij 23 families (29%) zijn de mutaties in beide allelen geïdentificeerd en bij 27 families (34%) werd maar 1 mutatie in 1 allel gevonden. Waarschijnlijk zijn intronmutaties die de splicing van het gen beïnvloeden of mutaties in de regulatoire sequenties of deleties van delen van het gen verantwoordelijk voor de ontbrekende genetische defecten. Wanneer we aannemen dat alle USH2 patiënten met minimaal 1 gemuteerd *USH2A* allel in feite USH2a patiënten zijn dan kan worden afgeleid dat 23% van de Nederlandse USH2 patiënten pathogene mutaties in een ander USH2 gen moeten hebben. Drie nieuwe, niet eerder beschreven, USH2a veroorzakende mutaties (R317R, Q748X en Q1468X) worden beschreven. In totaal zijn er 10 verschillende mutaties gevonden die USH2a in Nederland veroorzaken. Typisch Nederlandse mutaties zijn de C419F, W409X en de R317R mutatie, die tot nu toe

geïdentificeerd zijn bij 16, 7 en 4 allelen in respectievelijk 15, 6 en 4 families. De C419F en E767fs mutatie zijn foundermutaties op basis van een haplotype dat afgeleid is van 10 verschillende nucleotide polymorfismen.

Het laatste deel van dit hoofdstuk beschrijft de klinische en genetische kenmerken van de eerste USH3 familie die in Nederland is geïdentificeerd. Twee patiënten van deze familie hebben een nieuwe homozygote *USH3* mutatie: 149-152delCAGG + ins TGTCCAAT. Eén patiënt is volledig doof in aanwezigheid van een normale vestibulaire functie en retinitis punctata albescens, terwijl de andere patiënt een zelfde type gehoorverlies heeft met een goed ontwikkelde spraak en daarbij vestibulaire areflexie en retinitis pigmentosa sine pigmento heeft. Op basis van deze bevindingen kan geconcludeerd worden dat USH3 gemakkelijk kan worden verward met zowel USH1 als USH2.

**Hoofdstuk 4** is gericht op de audiovestibulaire kenmerken van het Wolfram syndroom. Bij deze studie zijn 11 Wolfram syndroom patiënten (4 mannen en 7 vrouwen) en 17 familieleden betrokken die heterozygote mutatie drager zijn. Zowel de patiënten als de mutatie dragers zijn geïdentificeerd op basis van pathogene mutaties in het *WFS1* gen. Geen van de mutatie dragers heeft een perceptief gehoorverlies. De patiënten hebben over het algemeen een perceptief gehoorverlies in de hoge frequenties dat in de loop der jaren toeneemt. De enige twee patiënten met missense mutaties in het *WFS1* gen hadden een normaal gehoor voor hun leeftijd en opvallend milde Wolfram kenmerken. Deze twee patiënten zijn daarom uitgesloten van verdere analyse. De 9 overgebleven patiënten hebben inactiverende *WFS1* mutaties, en voor hen is aangetoond dat de 5 vrouwelijke patiënten significant slechter horen dan de 4 mannelijke patiënten. De vrouwelijke patiënten vertoonden een jaarlijkse toename van hun gehoorverlies van 1,5-2,0 decibel voor de lage frequenties en 4,0-4,5 decibel voor de midden en hoge frequenties. Het spraakverstaan van de vrouwelijke patiënten begon af te nemen (90% score) vanaf de leeftijd van 21 jaar bij een gemiddelde gehoordrempel van 78 decibel. Het spraakverstaan verslechterde met 4,0% per jaar bij een afname van 1,4% per decibel. Eén van de 6 vestibulair onderzochte patiënten bleek vestibulaire areflexie te vertonen.

**Hoofdstuk 5** beschrijft het audiometrisch profiel van twee families (Dutch III, 9 patiënten en Dutch IV, 4 patiënten) waarbij slechthorendheid in de lage frequenties (DFNA6/14) voorkomt. Heterozygote mutaties in het *WFS1* gen zijn

verantwoordelijk voor dit type van autosomaal dominant overervende nietsyndromale perceptieve slechthorendheid. De aangedane familieleden van deze 2 families vertonen een progressie van het gehoorverlies die groter is dan op basis van presbycusis verwacht zou mogen worden. De toondrempel neemt tussen de 0,6 en 1,0 decibel per jaar toe bij alle frequenties. Opvallend is ook dat de spraakverstaanscores in familie Dutch III significant meer afnemen bij toenemende gehoordrempel dan de scores in familie Dutch IV.

## CONCLUSIES

Dit promotieproject is erin geslaagd om te rapporteren over nieuwe klinische en genetische kenmerken van Usher syndroom, Wolfram syndroom en DFNA6/14. Daarnaast zijn er methodes voor het analyseren van progressief gehoorverlies ontwikkeld en beschreven. Een aantal interessante conclusies kunnen getrokken worden uit dit onderzoek. Het onderzoek naar het gehoorverlies van USH2a patiënten heeft aangetoond dat dit progressief is met een jaarlijkse toename van het gehoorverlies van ongeveer 0,5 decibel. Over het algemeen wordt echter aangenomen dat USH2a patiënten een stabiel gehoorverlies met lichte toename door presbycusis hebben. Daarnaast is aangetoond dat de visus bij 19 USH1b patiënten niet significant verschilde van de visus bij 40 USH2a patiënten. Longitudinale analyses van de visus bij USH2a patiënten liet echter zien dat de visus-afname bij hogere leeftijd begint maar dan sterker is dan op basis van de cross-sectionele studies is berekend. De visus is rond 40-50 jarige leeftijd voor USH1b en USH2a ongeveer gelijk. Tevens is aangetoond dat USH2a patiënten zelden normale vestibulaire responsies hebben en dat de OKN gain significant afneemt en de tijdconstante T significant toeneemt met de leeftijd. Een andere opvallende bevinding was het verschil in gehoorverlies tussen mannelijke en vrouwelijke patiënten met Wolfram syndroom en inactiverende mutaties in het *WFS1* gen. De vrouwelijke patiënten hadden significant meer gehoorverlies dan de mannelijke patiënten.

Het belang van het verrichten van dit soort studies kan het beste geïllustreerd worden aan de hand van de enorme toename aan kennis van de afgelopen jaren. Tien jaar geleden waren nog maar een paar slechthorendheidsgenen geïdentificeerd en was nog maar weinig bekend over de functie van de corresponderende eiwitten in het binnenoer. Zonder uitgebreide familiestudies

zou deze kennis nooit zo snel verkregen kunnen zijn. Door het uitvoeren van koppelingsanalyse bij families met erfelijke nietsyndromale of syndromale slechthorendheid kunnen nieuwe genen geïdentificeerd worden en kan de rol van de betrokken eiwitten in het binnenoor onderzocht worden. De enorme ontwikkeling in kennis van binnenoorgen wordt het best geïllustreerd in paragraaf 1.3, waarin de moleculaire genetica van perceptieve slechthorendheid beschreven wordt. Het analyseren van de klinische kenmerken van families met erfelijke slechthorendheid zal echter steeds belangrijker worden om de moleculaire genetici zo optimaal mogelijk te kunnen assisteren, zeker gezien het feit dat de meeste van de veel voorkomende genen al geïdentificeerd zijn.

Studies zoals de huidige zijn dan ook van belang voor de patiënten en hun familieleden omdat ze uitgebreider en nauwkeuriger geïnformeerd kunnen worden over de aandoening waaraan ze leiden. In een maatschappij waarin de patiënten steeds mondiger worden en steeds meer willen weten over hun ziekte, moeten we in staat zijn deze informatie te verschaffen. Daarnaast is diagnostische mutatie-analyse tegenwoordig ook beschikbaar en kan er een preciese diagnose gesteld worden. Om kosteneffectief te blijven, dient een correcte klinische diagnose de aanvraag voor diagnostische mutatie-analyse te vergezellen. Voor het stellen van deze klinische diagnose is het van belang dat er grondige fenotype-genotype correlatiestudies zijn of worden uitgevoerd. Wanneer mutatie-analyse voor handen is, is het zelfs mogelijk om dragerschap van niet-aangedane familieleden te laten onderzoeken en kan er zelfs prenatale DNA-diagnostiek aangeboden worden. Concluderend kunnen we dan ook stellen dat dergelijke ontwikkelingen de kwaliteit van de genetische counseling ten goede komen.

De houding en bereidheid van patiënten om mee te werken aan het soort onderzoek dat in dit proefschrift wordt beschreven toont het sociaal-emotionele belang voor hen duidelijk aan. Het valt te hopen dat dit project en toekomstige soortgelijke projecten uiteindelijk dan ook zullen leiden tot toepasbare behandelingen van deze en vele andere vormen van erfelijk syndroomaal en nietsyndroomaal gehoorverlies.



## DANKWOORD

Mede dankzij de inzet en steun van velen is dit proefschrift tot stand gekomen. Op deze plaats zou ik hen graag bedanken. In dit proefschrift wordt onderzoek beschreven dat alleen maar door de bereidwilligheid van vele families tot stand heeft kunnen komen. Bij deze wil ik hen bedanken voor hun medewerking aan deze projecten en de vele hartelijke ontvangsten die ik heb mogen beleven.

Professor Cremers, u wil ik als eerste bedanken. Het is bewonderenswaardig te zien hoe u altijd onvoorwaardelijk tijd voor mij vrijmaakt(e) voor overleg. De u kenmerkende toewijding en betrokkenheid, niet alleen bij dit project maar ook bij de vele andere door u geleide projecten, hebben u tot een voortreffelijke manager in de erfelijke slechthorendheidsleer gemaakt. Professor Deutman, u wil ik bedanken voor de vele momenten die u voor mij vrij maakte voor overleg over oogheelkundige aspecten van het onderzoek. Ik herinner me nog goed dat u zei dat de vakken keel-, neus- en oorheelkunde en oogheelkunde vroeger verwant waren en ik ben blij dat u mij wat van de oogheelkunde heeft laten zien. Vervolgens wil ik mijn co-promotoren Hannie Kremer en Patrick Huygen bedanken. Beste Hannie, bedankt voor jouw grote steun aan dit project, met name op momenten dat de genetische details me verwarden was jij er altijd om de zaken weer op een logisch rijtje te zetten. Zonder jouw tomeloze inzet had ik niet de kans gehad om in het laboratorium van de Moleculaire Genetica te werken, hetgeen een unieke ervaring voor mij is geweest. Beste Patrick, jouw hand is ook in dit proefschrift duidelijk terug te zien. Vanaf deze plek wil ik graag je werklust en kennis roemen. Ik ben blij dat ik daar zoveel van heb mogen leren en bij deze neem ik graag een abonnementje op de toekomst, zodat we door kunnen gaan met het bespreken van interessante families en of patiënten en de achterliggende pathofysiologische processen van slechthorendheid en vestibulaire afwijkingen.

De staf van de afdeling keel-, neus- en oorheelkunde van het UMC St Radboud wil ik bedanken voor de mogelijkheid die ze me geboden hebben om dit onderzoek te verrichten in combinatie met de opleiding tot keel-, neus- en oorarts. Bill Kimberling, Guy Van Camp, Kim Cryns, Jody van den Ouweland, Bert Dikkeschei en Frans Cremers wil ik bedanken voor de prettige samenwerking op klinisch-genetisch niveau. Daarnaast gaat mijn dank ook uit naar de medewerkers van het laboratorium Moleculaire Genetica en in het bijzonder de Otogenetica-medewerkers: Heleen te Brinke, Erwin van Wijk, Arjan de Brouwer en Mirjam

Luijendijk. Mariette Wagenaar en Annelies van Aarem wil ik bedanken voor de mooie erfenis die ze achtergelaten hebben, ik hoop dat ze blij zijn met de voortgang van hun Usher-project.

Vele mensen gaven ondersteuning tijdens het patiënten-onderzoek, waarvoor ik hen graag wil bedanken: Martien Nicolassen, de medewerkers van het volwassen audiologisch centrum van het UMC St. Radboud, Evert-Jan Steenbergen en Albert Aanderkerk voor de retina-fotografie en de medewerkers van de afdeling bijzondere onderzoeken van de afdeling oogheelkunde (dit proefschrift is van “die jongen van de KNO”). Mijn collega-assistenten Annemarie, Robbert, Kitty, Antoon, Dirk, Capi, Martin, Laura, Steven, Bas, Karien, Savitri, Martijn, Niels, Brechtje, Erik, Els, Myrthe, Anne, Liselotte, Rutger, Stijn, Ilse, Olivier, Lien, Bart en Godelieve wil ik bedanken voor de collegiale, goede sfeer en met name voor de gezellige borrels en nerd-diners! Diny Helsper-Peters wil ik graag bedanken voor haar hulp bij de lay-out van dit proefschrift.

Mijn vrienden wil ik graag bedanken voor alle gezellige momenten/weekenden en al hun stimulerende en vooral ook “relativerende” opmerkingen. Frank Hoentjen, als paronymf wil ik je bedanken voor de stimulerende onderzoeksomgeving die we samen gecreëerd hebben op de van Berchenstraat, dit proefschrift is daar mede een gevolg van. Cock en Willy, Iljoesja en Taco, Claudia, Fridjof en Justin, ik ben blij dat jullie als familie bij mijn promotie aanwezig zijn.

Tot slot het meest dierbare. Lieve Jasper en Brenda, jullie wil ik bedanken voor alle gezellige, leuke en steunende momenten die we gedeeld hebben en nog zullen gaan delen. Jap, ik ben er trots op dat jij straks naast me staat als paronymf! Lieve pa en ma: jullie wil ik heel graag bedanken voor het feit dat jullie er altijd en onvoorwaardelijk voor ons zijn, in goede en in slechte tijden. Daarnaast wil ik jullie bedanken voor de stimulerende manier van opvoeden. Je bereikt pas iets in het leven wanneer je er voor gaat en ik ben blij dat ik dat van jullie heb mogen leren. We gaan er voor en carpe diem! Lieve Patricia, de afgelopen tijd ben ik me nog meer gaan realiseren hoe belangrijk je voor me bent. Jouw steun en liefde zijn essentiële voorwaarden (You make me feel good!) voor het succesvol afronden van dit proefschrift geweest. Bedenk goed dat een zeeman nooit alleen de zee op gaat!

## CURRICULUM VITAE

Ronald Johannes Elisabeth Pennings werd geboren op 17 april 1975 te 's-Hertogenbosch. Na het doorlopen van zijn lagere en middelbare school behaalde hij in 1993 zijn VWO diploma aan het Rodenborch College te Rosmalen om vervolgens te vertrekken naar België om aan de Katholieke Universiteit van Leuven Geneeskunde te studeren. Na het behalen van zijn eerste kandidatuur, vertrok hij in 1994 naar Nijmegen om deze studie aan de Katholieke Universiteit Nijmegen te vervolgen. In 1998 rondde hij deze studie af (cum laude) en in maart 2001 behaalde hij het artsexamen met het predikaat cum laude. Vanaf eind 1996 verrichte hij onder supervisie van Dr. F.J.A. van den Hoogen wetenschappelijk onderzoek aan de afdeling keel-, neus- en oorheelkunde van het (toen nog) Academisch Ziekenhuis Nijmegen. In augustus 1998 ging hij naar Hong Kong voor een facultatieve klinische stage aan de afdelingen chirurgie en keel-, neus- en oorheelkunde van het Prince of Wales Hospital. Zijn wetenschappelijke stage verrichte hij van oktober tot december 2000 onder supervisie van Prof. Dr. R.T. Gregor aan de afdeling keel-, neus en oorheelkunde van het Tygerberg ziekenhuis te Kaapstad (Zuid-Afrika) en betrof de laser microchirurgische verwijdering van larynx en hypopharynx tumoren. Vanaf april 2001 werkte hij als assistent-geneeskundige in opleiding tot klinisch onderzoeker (AGIKO) aan deze promotiestudie en is hij begonnen met de opleiding tot keel-, neus- en oorarts aan de afdeling keel-, neus- en oorheelkunde van het UMC St. Radboud, die hij in 2008 zal afronden.



## LIST OF PUBLICATIONS

**International publications**

- 1 Laser treatment of symptomatic anterior pharyngeal pouches after laryngectomy. **RJE Pennings**, FJA van den Hoogen, HAM Marres. *Head Neck* 1999 Jul;21(4):310-4.
- 2 Giant laryngoceles: a cause of upper airway obstruction. **RJE Pennings**, FJA van den Hoogen, HAM Marres. *Eur Arch Otorhinolaryngol* 2001 Mar;258(3):137-140.
- 3 Mutations in the WFS1 gene that cause low-frequency sensorineural hearing loss are small non-inactivating mutations. K Cryns, M Pfister, **RJE Pennings**, SJH Bom, K Flothmann, G Caethoven, H Kremer, I Schatteman, KA Koln, T Tóth, S Kupka, N Blin, P Nurnberg, H Thiele, PH Van de Heijning, W Reardon, D Stephens, CWRJ Cremers, RJH Smith, G Van Camp. *Hum Genet* 2002;110:389-394.
- 4 Hearing impairment in Usher's syndrome. **RJE Pennings**, M Wagenaar, A van Aarem, PLM Huygen, WJ Kimberling, CWRJ Cremers. *Advances in Otorhinolaryngology*, eds. CWRJ Cremers & RJH Smith, volume 61, 2002;61:184-191.
- 5 Pure tone hearing thresholds and speech recognition scores in Dutch patients carrying mutations in the USH2A gene. **RJE Pennings**, PLM Huygen, MD Weston, A van Aarem, M Wagenaar, WJ Kimberling, CWRJ Cremers. *Otol Neurotol* 2003;24:58-63.
- 6 Mutations in the calcium-binding motifs of CDH23 and the 35delG mutation in GJB2 cause hearing loss in one family. APM de Brouwer, **RJE Pennings**, M Roeters, P Van Hauwe, LM Astuto, LH Hoefsloot, PLM Huygen, B van den Helm, AF Deutman, JM Bork, WJ Kimberling, FPM Cremers, CWRJ Cremers, H Kremer. *Hum Genet* 2003;112:156-163.
- 7 Progression of low-frequency sensorineural hearing loss (DFNA6/14-WFS1). **RJE Pennings**, SJH Bom, K Cryns, K Flothmann, PLM Huygen, H Kremer, G Van Camp, CWRJ Cremers. *Arch Otolaryngol Head Neck Surg* 2003;129:421-426.
- 8 Molecular characterization of WFS1 in patients with Wolfram syndrome. JMW van den Ouweland, K Cryns, **RJE Pennings**, I Walraven, GMC Janssen, JA Maassen, JC van Swieten, BFE Veldhuijzen, AB Arntzenius, D Lindhout, CWRJ Cremers, G Van Camp, LD Dikkeschei. *J Mol Diagnost* 2003;5:88-95
- 9 Characterizing and distinguishing progressive phenotypes in nonsyndromic autosomal dominant hearing impairment. PLM Huygen, **RJE Pennings**, CWRJ Cremers. *Audiol Med* 2003;1:37-46.
- 10 A review of progressive phenotypes in nonsyndromic autosomal dominant hearing impairment. **RJE Pennings**, PLM Huygen, G Van Camp, CWRJ Cremers. *Audiol Med* 2003;1:47-55.

- 11 Usher syndrome type III can mimic other types of Usher syndrome **RJE Pennings**, RR Fields, PLM Huygen, AF Deutman, WJ Kimberling, CWRJ Cremers *Ann Otol Rhinol Laryngol* 2003,112 525-530
- 12 Mutational spectrum of the WFS1 gene in Wolfram syndrome, nonsyndromic hearing impairment, diabetes mellitus and psychiatric genetics K Cryns, T Sivakumaran, JMW van den Ouweland, **RJE Pennings**, CWRJ Cremers, K Flothmann, T-L Young, RJH Smth, MM Lesperance, G Van Camp *Hum Mutat* 2003,22 275-287
- 13 Progressive or nonprogressive hearing loss in Usher syndrome type II? - Letter to the editor **RJE Pennings**, PLM Huygen, CWRJ Cremers *Ann Otol Rhinol Laryngol* 2003,112-825
- 14 Sex-related hearing impairment in Wolfram syndrome patients identified by inactivating WFS1 mutations **RJE Pennings**, PLM Huygen, JMW van den Ouweland, K Cryns, LD Dikkeschei, G Van Camp, CWRJ Cremers *Audiol Neurootol* 2004,9 51-62
- 15 Evaluation of visual impairment in Usher syndrome 1B and Usher syndrome 2A **RJE Pennings**, PLM Huygen, DJ Orten, M Wagenaar, A van Aarem, H Kremer, WJ Kimberling, CWRJ Cremers, A F Deutman *Acta Ophthalmol Scand* *in press*
- 16 USH2A mutation analysis in 70 Dutch families with Usher syndrome type II **RJE Pennings**, H te Brinke, MD Weston, A Claassen, DJ Orten, H Weekamp, A van Aarem, PLM Huygen, AF Deutman, L Hoefsloot, FPM Cremers, CWRJ Cremers, WJ Kimberling, H Kremer *Hum Mutat* *in press*
- 17 Identification of 51 novel exons of the Usher syndrome type 2A (USH2A) gene that encode multiple conserved functional domains, mutated in patients with Usher syndrome type II E van Wijk, **RJE Pennings**, H te Brinke, A Claassen, HG Yntema, LH Hoefsloot, FPM Cremers, CWRJ Cremers, H Kremer *Am J Hum Genet* *in press*
- 18 A fifth locus for otosclerosis, OTSC5, maps to chromosome 3q22-24 K Van Den Bogaert, EMR De Leenheer, CWRJ Cremers, Y Lee, P Nurnberg, **RJE Pennings**, K Vanderstraeten, RJH Smth, G Van Camp *J Med Genet* *in press*
- 19 Variable clinical features in patients with CDH23 mutations (USH1D-DFNB12) **RJE Pennings**, V Topsakal, L Astuto, APM de Brouwer, M Wagenaar, PLM Huygen, WJ Kimberling, AF Deutman, H Kremer, CWRJ Cremers *Otol Neurotol* *conditionally accepted*
- 20 Serial audiometry and speech recognition in Finnish USH3 patients RF Plantinga, L-M Kleemola, PLM Huygen, T Joensuu, E-M Sankila, **RJE Pennings**, CWRJ Cremers *Audiol Neurootol* *conditionally accepted*
- 21 Vestibular deterioration precedes hearing deterioration in the P51S COCH mutation (DFNA9) An analysis in 74 mutation carriers. AMLC Bischoff, PLM Huygen, MH Kemperman, **RJE Pennings**, SJH Bom, WIM Verhagen, R Admiraal, H Kremer, CWRJ Cremers *submitted*

- 22 Analysis of optokinetic and vestibular responses related to advancing age and increasing visual impairment in USH2a *PLM Huygen, RJE Pennings, MGM Nicolassen, W Verhagen, WJ Kimberling, H Kremer, AF Deutman, CWRJ Cremers submitted*
- 23 Early phenotype determination guiding rapid genotyping of an additional DFNA2/KCNQ4 family with a hotspot mutation *V Topsakal, RJE Pennings, H te Brinke, PLM Huygen, H Kremer, CWRJ Cremers submitted*
- 24 Identification and molecular modeling of a mutation in the motor head domain of myosin VIIA in a family with autosomal dominant hearing impairment (DFNA11) *M Luijendijk, E van Wijk, E Krieger, AMLC Bischoff, PLM Huygen, RJE Pennings, HG Brunner, CWRJ Cremers, FPM Cremers, H Kremer submitted*

### **National Publications**

- 1 Van gen naar ziekte, mutaties in het WFS1 gen als oorzaak van juveniele type 1 diabetes mellitus met opticus atrofie (Wolfram syndroom) *RJE Pennings, LD Dikkeschei, CWRJ Cremers, JMW van den Ouweland Ned Tijdschr Geneeskd 2002,146.985-987*
- 2 Van gen naar ziekte, genetische oorzaken van slechthorendheid, slechtzienheid en vestibulaire problemen (Usher syndroom) *RJE Pennings, H Kremer, AF Deutman, WJ Kimberling, CWRJ Cremers Ned Tijdschr Geneeskd 2002,146 2354-2358*
- 3 De CO<sub>2</sub> laser bij behandeling van tumoren van larynx en hypopharynx Eerste resultaten uit het Tygerberg ziekenhuis te Kaapstad en een review van de literatuur *RJE Pennings, FJA van den Hoogen, RT Gregor Ned Tijdschr KNO- Heelk 2003,9 7-14*
- 4 Van gen naar ziekte, niet-syndroomaal autosomaal dominant overerend laagfrequent perceptief gehoorverlies (DFNA6/14) *RJE Pennings, K Cryns, PLM Huygen, G Van Camp, CWRJ Cremers Ned Tijdschr Geneeskd 2003,44 2170-2172*

Stellingen behorende bij het proefschrift

# Hereditary Deaf-Blindness

*clinical and genetic aspects*

Ronald Pennings, 29 april 2004

1. Vrouwelijke patiënten met Wolfram syndroom dat wordt veroorzaakt door truncerende *WFS1* mutaties horen significant slechter dan mannelijke patiënten met Wolfram syndroom. *(dit proefschrift)*
2. Cross-sectionele analyse van het gezichtsveld en de gezichtsscherpte bij *USH1b* en *USH2a* patiënten laat geen significant verschil in progressie zien tussen deze groepen patiënten. *(dit proefschrift)*
3. De slechthorendheid bij patiënten met *DFNA6/14* kan ook een progressief karakter hebben. *(dit proefschrift)*
4. Mutaties in het *USH2A* gen zijn verantwoordelijk voor ongeveer 72% van de in Nederland voorkomende Usher syndroom type II families. *(dit proefschrift)*
5. Het *USH2A* gen bestaat uit 72 en niet zoals eerder beschreven 21 exonen. *(van Wijk et al. Am J Hum Genet 2004, in druk)*
6. De variatie in aanvang en progressie van het gehoorverlies bij patiënten met Usher syndroom type III zorgt er voor dat het klinisch zowel kan imponeren als Usher syndroom type I als Usher syndroom type II. *(Plantinga et al. Audiol Neurootol 2004, in druk)*
7. De analyse van het audiometrisch phenotype met behulp van de age-related typical audiograms (ARTA) en de threshold features array (TFA) is vooral zinvol indien er sprake is van een goede samenwerking met de onderzoekers die het genotype bestuderen.
8. De hoogte van de citation index van wetenschappelijke tijdschriften wordt in het huidige tijdperk mede bepaald door de elektronische beschikbaarheid van deze tijdschriften via internet.
9. Er is een sekseverschil in het plezier dat mensen ervaren wanneer zij gaan winkelen ("shoppen"). Mannen (de jagers) vinden het gemiddeld 72 minuten leuk om te winkelen. Vrouwen (de verzamelaars) vinden dit gemiddeld 100 minuten leuk. Stellen krijgen dan ook na gemiddeld 1 uur en 12 minuten shoppen ruzie. *(YouGov Research, September 2003, www.YouGov.com)*
10. Carpe diem

# Stellingen

behorende bij het proefschrift

*Characterizations of  $L^p$ -spaces with  $p \in (0, \infty)$*

van Steven Teerenstra

1. Laat  $X$  een compacte Hausdorffruimte zijn.

Dan zijn de volgende uitspraken equivalent:

( $\alpha$ )  $X$  is nul-dimensionaal i.e. de topologie van  $X$  heeft een basis van open-gesloten deelverzamelingen.

( $\beta$ ) Als  $0 \leq g_1, g_2 \leq f$  in  $C(X)$  met  $g_1, g_2$  disjunct, en  $\varepsilon > 0$  gegeven zijn, dan bestaan er  $0 \leq f_1, f_2$  in  $C(X)$  zodanig dat  $f = f_1 + f_2$  met  $f_1$  en  $f_2$  disjunct en  $f_i \geq g_i - \varepsilon f$  ( $i = 1, 2$ ).

2. De implementatie van referentiële integriteit binnen MS Access is een farce.

3. Er bestaat geen quantum wereld.

Er zijn slechts de verschijnselen.

4. Reïficatie, het toedichten van werkelijkheidsgehalte aan theoriegeladen concepten, objecten en/of relaties, is een vorm van hubris.

5. Een formule zegt meer dan 1000 woorden.

6. De vorming van de promovendus of promovenda is een belangrijker resultaat van het promotietraject dan de door hem of haar geschreven artikelen.

7. In het boek dat leven heet, heeft God letterlijk geen betekenis.







