

**Reusing Brick:
Properties of Brick to Mortar Bond Strength**

Mary S. Park

Submitted in partial fulfillment of the requirements for the degree
Master of Science in Historic Preservation

Graduate School of Architecture, Planning and Preservation
Columbia University
May 2013

Abstract

Brick and mortar is one of the most common wall systems used in the past several thousand years. These two components have evolved over the centuries as has our scientific understanding of their performance. As brick and mortar wall science develops industry professionals need to reevaluate the design criteria, means and methods of construction and the performance expectations for these advanced wall systems. Building with used bricks was last critically evaluated over 80 years ago and based on the findings at that time; the industry has generally avoided rebuilding with used bricks. However, much has changed since then and this thesis revisits the topic of reusing bricks.

This thesis addresses the performance of brick to mortar bond strength when reusing the same brick. This study aims to clarify the role of brick cleaning methods on flexural bond strength and to provide information that will improve the performance of brick to mortar building construction.

Based on the results obtained, the following conclusions were made

1. New bricks had the highest initial rate of absorption (IRA), followed by reclaimed bricks cleaned via Stage 1, Stage 2 and Stage 3 procedures.
2. The flexural bond strength of brick to mortar increases as brick is cleaned more forcefully. Washing bricks with acid proved to be the most effective in increasing bond strength.
3. Flexural bond strength decreases as the average IRA of bricks increases.
4. Flexural bond strength of reclaimed brick is higher than that of new brick. Flexural bond strengths increased after mortar was applied for the second time.

Acknowledgements

I would like to sincerely thank Michael Lynch, my advisor and advocate all year. Thank you for your guidance and support throughout this process. I greatly appreciate all of the time and effort that helped me complete this thesis. Thank you to my readers, Joan Berkowitz and Norman Weiss for their helpful comments.

Thank you to Joe and Henry at the International Masonry Institute for constructing my numerous sample prisms. Thank you to Simpson, Gumpertz and Heger for the use of their laboratory facilities and especially to Art Davies, Brendon Willey and Casey Sturup for helping me with testing. Thank you to Dan Allen for providing me with brick samples. Thank you to Paul Millman whose initial inquiry led to this thesis topic.

Thank you to my family and friends. 엄마, 아빠, 오빠, 조 사랑해요.

Contents

Abstract	i
Acknowledgements	ii
List of Tables	v
List of Figures	vi
Chapter 1: Introduction	1
Chapter 2: Literature Review	3
2.1 Bond Strength and Brick Properties	4
2.2 Bond Strength and Mortar Properties	6
2.3 Bond Strength and Curing	7
2.4 Bond Strength of Used Bricks	8
2.5 Bond Strength Testing Standards	11
2.6 Building Codes	13
Chapter 3: Design of Experiment	15
3.1 Brick	15
3.2 Mortar	17
3.3 Construction Techniques	19
3.4 Curing Conditions	21
3.5 Cleaning	22
3.6 Measurement of Bond Strength	23
Chapter 4: Test Program	25
4.1 Brick	25
4.2 Mortar	27
4.3 Construction Techniques	29
4.4 Curing Conditions	30
4.5 Cleaning	32
4.6 Measurement of Bond Strength	32
4.6.1 Bond Wrench Apparatus	32
4.6.2 Four-point Bend Apparatus	36
Chapter 5: Results	38
5.1. Testing	38
5.1.1 Physical Properties	38
5.1.2 Sample Preparation	40
5.1.3 Testing Procedures	42

5.1.4 Cleaning Tests.....	44
5.1.4 Final Testing.....	45
5.2 Water Absorption Results	46
5.3 Bond Wrench Results	47
5.4 Four-point Bend Results	49
Chapter 6: Analysis	50
6.1 Brick Properties	50
6.1.1 Water Absorption.....	50
6.1.2 Surface Pores	52
6.1.3 Water Absorption v. Pore Surface.....	54
6.2 Bond Properties	56
6.2.1 Cohesion.....	56
6.2.2 Adhesion.....	58
6.3 Flexural Bond Strength.....	61
6.3.1 Flexural Bond Strength v. Surface Pores.....	61
6.3.2 Flexural Bond Strength v. Water Absorption	62
6.4 Other Parameters Affecting Flexural Bond Strength.....	64
6.4.1 Moisture Content	64
6.4.2 Age.....	64
6.4.3 Temperature.....	65
6.5 Building Code Requirements	67
Chapter 7: Conclusion.....	68
7.1 Limitations.....	68
7.2 Test Results	68
7.3 Future Study	70
Appendix	71
A.1 First set of brick.....	71
A.2 Microscope Photos.....	72
Bibliography.....	83

List of Tables

Table 1 - Allowable flexural tensile stresses for clay and concrete masonry, psi (kPa)	14
Table 2 - Physical Properties of Bricks	26
Table 3 - Guide to the Selection of Masonry Mortars.....	27
Table 5 - Glen-Gery Color Mortar Blend Specification Sheet.....	29
Table 6 - Initial Rate of Absorption of Bricks.....	50
Table 7 - Photographs of Brick Pores Before and After Cleaning.....	53
Table 8 - Initial Rate of Absorption of Mortar.....	54
Table 9 - Initial Rate of Absorption of Brick After 1 st and 2 nd Mortar Application	56
Table 10 - Average flexural strength of specimens	59
Table 11 - Average flexural strength of specimens by failure method.....	60
Table 12 - Glen-Gery Brick Size, Coverage and Weight.....	71

List of Figures

Figure 1 - Effect of Age on Bond Strength	22
Figure 2 - Photos of standard Watson town Brick Used in Experiment.....	26
Figure 3 - Glen-Gery Color Mortar Blend Bag	28
Figure 4 - Mason Constructing Sample Prisms	30
Figure 5 - Samples Curing in Sealed Plastic Bags for Initial 48 Hours	31
Figure 6 - Bond Wrench Testing Apparatus	33
Figure 7 - Bond Wrench Testing Apparatus Secured within MTS Testing Machine	34
Figure 8 - Basic principle of bond wrench test (A) before and (b) after loading	34
Figure 9 - Free Body Diagram of the Mortar-Unit Interface Under Testing Conditions	35
Figure 10 - ASTM E518 Flexural strength test set up.....	36
Figure 11 - Moment Diagram for Four-point Bending Test.....	37
Figure 12 - Weighing of Samples.....	39
Figure 13 - Water Absorption Tests.....	39
Figure 14 - Sample Documentation	40
Figure 15 - Sample Surface Pore Structure	40
Figure 16 - IMI Mason Building Prisms	41
Figure 17 - 7-day Cured Sample Prisms Ready for Testing.....	42
Figure 18 - Four-point Bending Test Setup	43
Figure 19 - Bond Wrench Test Setup	44
Figure 20 - Graph of Brick Water Absorption.....	51
Figure 21 - Graph of IRA vs. Cleaning Method	55
Figure 22 - Percentage of Bond Wrench Test Prisms Displaying Each Failure Mode	57
Figure 23 - Percentage of 4-point Bend Test Prisms Displaying Each Failure Mode.....	58
Figure 24 – Flexural Strength vs. Cleaning Method	62
Figure 26 - Flexural Strength vs. Average IRA.....	63
Figure 27 - High and Low Temperature for During Curing of Sample Prisms	66

Chapter 1: Introduction

Brick and mortar is one of the most common wall systems used in the past several thousand years.¹ It is used successfully in many regions of the world and continues to be an important building system. The two components that make up a brick wall are the masonry unit and the mortar. These two components have evolved over the centuries as has our scientific understanding of their performance. From the earliest sun-baked mud bricks bonded with mud mortar up to the current day high-fired shale bricks bonded with high strength cement mortars, the objective of brick and mortar technology has been to build stronger and more durable wall systems.

Understanding bond strength properties is essential in the design and construction of brick walls. Inadequate bond strength can lead to cracking in masonry unit construction which can cause extensive damage because it is a brittle mode of failure. Anticipating failure due to inadequate bond strength is difficult to predict visually and could potentially lead to widespread damage, and eventually lead to catastrophic failure if a high force load is applied.²

As brick and mortar wall science develops industry professionals need to reevaluate the design criteria, means and methods of construction and the performance expectations for these advanced wall systems. Building with used bricks was last critically evaluated over 80 years ago and based on the findings at that time; the industry has generally avoided rebuilding with used bricks. However, much has changed since then and this thesis revisits the topic of reusing bricks. This topic was brought to my attention during my 2012 summer

¹ James W.P. Campbell, *Brick: A World History* (London: Thames & Hudson, 2003).

² "Bond Strength in Masonry Construction," *Cement, Concrete & Aggregates Association of Australia Technical Notes*, no. 65 (2001): 1, accessed February 28, 2013. <http://www.concrete.net.au/publications/pdf/TN65.pdf>

internship at Superstructures Engineers and Architects in New York City. Engineers and architects were repeatedly told by contractors and construction managers to not specify the use of reclaimed bricks because of poor bond strength. While many professionals are aware of the perception, little research has been completed that supports this conclusion.

This thesis addresses the performance of brick to mortar bond strength when reusing the same brick. It is important to make the distinction between salvaged brick and reclaimed brick. These terms are often used interchangeable in the construction field, but are distinctively two separate types of material. As defined in this thesis, salvaged brick is taken from multiple locations with unknown sources. Salvaged brick are often collected from various demolition sites and mixed together at a brick yard. Purchasers of salvaged brick do not know the origins of the bricks or their physical properties. Alternatively, reclaimed bricks are taken from a specific location. Usually they have been used in a current wall system that for any number of reasons is disassembled or has failed. These bricks are cleaned for reuse in the same wall system. Reclaimed bricks are frequently used when rebuilding wall systems because of their historic appearance and compatibility with surrounding masonry. When a wall is dismantled or collapses for any reason, owners and landmarks regulatory agencies often desire that it be rebuilt using the same bricks to maintain the overall aesthetic quality. However, contractors are often resistant to reuse bricks because of the perception that reclaimed bricks do not provide for a strong wall.

This thesis intends to clarify bond strength characteristics of reclaimed bricks, not salvaged bricks. This study aims to clarify the role of brick cleaning methods on flexural bond strength and to provide information that will improve the performance of brick to mortar building construction.

Chapter 2: Literature Review

A review of brick to mortar bond strength research generated many publications on the subject. Because many factors contribute to bond strength, the topic is of much interest to researchers.

Several studies have added to the understanding of bond theory. “An Experimental Study of the Interface between Brick and Mortar”³ by S. Lawrence and H.T. Cao is an important paper that established that when mortar comes into physical contact with brick, interlocking hydration products transfer to the brick surface and into its pores, forming a mechanical bond.⁴ L. Kampf’s “Factors Affecting Bond between Bricks and Mortar” concluded that the mechanical bond was a larger contributing factor to bond strength than the chemical bond.⁵ Lawrence and Cao concluded that the bond between brick and mortar is a result of permeation of the mortar and hydration products into the brick surface voids and pores.⁶

In addition to the chemical and mechanical theories that explain brick to mortar bond, several studies have been published addressing the relationship of bond strength and brick and mortar properties. Many of these recent studies focus on the physical properties of brick or center on mortar curing conditions, effects of mortar aging and mortar mixture compositions. These foundational studies have established the importance of bond strength in the construction community and testing standards were developed to measure bond strength in various forms.

³ S. Lawrence and H.T. Cao, “An Experimental Study of the Interface between Brick and Mortar,” (paper presented at the 4th North American Masonry Conference, Los Angeles, California, 1987).

⁴ Ibid.

⁵ Leo Kampf, “Factors Affecting Bond,” 140.

⁶ Lawrence and Cao, “An Experimental Study,” 14.

2.1 Bond Strength and Brick Properties

One of the most comprehensive studies of bond strength and its relation to brick and mortar properties is “A Study of the Properties of Mortars and Brick and their Relation to Bond” by L.A. Palmer and D.A. Parsons.⁷ This research paper was published in 1934 by the United States Department of Commerce as part of the Bureau of Standards Journal of Research. In this study, 50 mortars and 6 different bricks were tested to determine bond strength in tension, bond durability, transverse strength of brick beams and compressive strength of brick piers.

Another extensive study titled “Factors Affecting Bond Strength and Resistance to Moisture Penetration of Brick Masonry” is by T. Ritchie and J.I. Davison.⁸ It provided a study on the effects of brick and mortar properties of moisture penetration and bond strength. In this report, Ritchie and Davison constructed small panels of brick and measured bond strength using the crossed brick couplet method except that the entire bedding surface of the bricks was in contact with mortar.⁹ Ritchie and Davison investigated the influence of the initial rate of absorption (IRA) of brick on bond strength. Bond strength reached maximum values when brick suction ranged between 10 to 20g/min/30in². Bond strength decreased significantly for bricks with an IRA of more than 30g/min/30in². They also tested the common practice of wetting bricks before laying. When wetting high-suction bricks, the bond strength increased. And finally, the bond strength of cored bricks was found to be lower than that of solid bricks.

⁷ L.A. Palmer and D.A. Parsons, “A Study of the Properties of Mortars and Bricks and their Relation to Bond,” *Bureau of Standards Journal of Research* 12, no. 5 (1934).

⁸ T. Ritchie and J.I. Davison. “Factors affecting Bond Strength and Resistance to Moisture Penetration of Brick Masonry,” in *Symposium on Masonry Testing, ASTM STP 320* (Philadelphia: American Society for Testing and Materials, 1963).

⁹ *Ibid.*, 18.

W. Mark McGinley presented an experimental program that evaluated the IRA of bricks and its effects on flexural bond strength. Prepackaged masonry cement and wire cut extruded bricks were used in this study. The testing program analyzed six joints per mortar type and brick type combination using the bond wrench apparatus (see Section 4.6.1 for a complete description). Procedures followed “ASTM C1072 Standard Test Methods for Measurement of Masonry Flexural Bond Strength”¹⁰. The results of the brick tests indicated that flexural bond is reduced at high and low brick IRA. McGinley states the “optimum IRA range” is between 5 and 10 g/min/30in² for type N mortar and between 5 and 15 g/min/30in² for type S mortar.¹¹

The bond strength of low IRA bricks was studied by J. Gregg Borchelt and J.A. Tann. In their research program, extruded bricks with low brick IRA were combined with seven different mortars and tested for flexural bond strengths using the bond wrench apparatus.¹² Results showed that the flexural bond strength of low IRA brick improved as mortar water retention decreased.¹³ Water retention was defined as “the ability of mortar to resist the loss of water to an absorptive masonry unit.”¹⁴ The flexural bond strengths of very low IRA brick can equal or exceed those of higher IRA brick with proper selection of materials and types.¹⁵

¹⁰ American Society for Testing and Materials, “ASTM C1072-11: Standard Test Methods for Measurement of Masonry Flexural Bond Strength,” doi:10.1520/C1072-11.

¹¹ W. Mark McGinley, “IRA and the Flexural Bond Strength of Clay Brick Masonry,” in *Masonry: Components to Assemblages, ASTM STP 1063*, ed. John H. Matthys (Philadelphia: American Society for Testing and Materials, 1990), 226-227.

¹² J. Gregg Borchelt and J.A. Tann, “Bond Strength and Water Penetration of Low IRA Brick and Mortar.” (paper presented at the 7th North American Masonry Conference, South Bend, Indiana, 1996), 1.

¹³ *Ibid.*, 4.

¹⁴ *Ibid.*

¹⁵ Borchelt and Tann, “Bond Strength and Water Penetration,” 4.

2.2 Bond Strength and Mortar Properties

Palmer and Parsons also examined three other important factors that affect bond strength: brick suction, water retaining capacity of mortar and strength of mortar. The bond strength increased with the Portland cement content and decreased with the lime content for low to moderate suction brick (approximately 20 to 60g/min/30in²).¹⁶ However for high suction brick (more than 60g/min/30in²), the bond strength of medium to high lime content mortar was higher than that of straight cement mortar.¹⁷ Higher bond strengths were also exhibited in mortars with the highest compressive strength. Results also concluded that mortars with high-retaining capacity were also conducive to good bond strength.

Richie and Davison tested two properties of mortar in relation to the performance of bond strength: the consistency of fluidity of a particular mortar when it is being used in laying bricks (mortar flow) and its water retention value. Flow is a relative measure of workability and can be determined by the procedure outlined in “ASTM C1437 Standard Test Method for Flow of Hydraulic Cement Mortar”.¹⁸ Water retention can be determined by “ASTM C1506 Standard Test Method for Water Retention of Hydraulic Cement-Based Mortars and Plasters”.¹⁹ Mortars were composed of 1:1:6 (Portland cement:lime:sand) and the flow varied from 104 to 136 percent for each test panel. Studies indicated that high-flow mortars exhibited higher bond strength while low-flow mortars exhibited lower bond

¹⁶ Palmer and Parsons, “A Study of the Properties of Mortars and Bricks,” 4.

¹⁷ Ibid.

¹⁸ American Society for Testing and Materials, “ASTM C1437-07: Standard Test Method for Flow of Hydraulic Cement Mortar,” doi:10.1520/C1437-07.

¹⁹ American Society for Testing and Materials, “ASTM C1506-09: Standard Test Method for Water Retention of Hydraulic Cement-Based Mortars and Plasters,” doi:10.1520/C1506-09.

strengths.²⁰ Findings also show that as the water retention value of the mortar increased, the strength of bond also tended to increase.²¹

In 1985, Edward Gazzola, Dino Bagnariol, Janine Toneff and Robert G. Drysdale of McMaster University conducted a study on the influence of mortar materials on the flexural tensile strength of brick. The results indicated a significant decrease in tensile bond for mortars made with masonry cement versus mortars made with Portland cement-lime.²²

2.3 Bond Strength and Curing

N. De Vitis, Adrian W. Page and Stephen Lawrence of the University of Newcastle in Australia studied the effect of curing age on bond strength. Two brick and mortar combinations were cured under laboratory conditions and tested from 1 to 180 days.²³ Prisms were constructed using two types of clay brick and a 1:1:6 proportioned mortar. The results indicated that after 3 days, mortars reached 70-100% of its 7-day strength. And after 7 days, there was an overall gain in strength. However, results also showed “up and down” behavior, indicating gains and losses of strength during curing. Overall results showed that 7 day mortars reached approximately 65% of their final strengths.²⁴

Heber Sugo, Adrian W. Page and Stephen Lawrence studied the effect of age on bond strength and mortar microstructure. In their investigation a single brick and mortar combination was cured under laboratory conditions and bond strength was determined at

²⁰ Richie and Davison, “Factors Affecting Bond Strength,” 23.

²¹ Ibid., 24.

²² Edward Gazzola et al., “Influence of Mortar Materials on the Flexural Tensile Bond Strength of Block and Brick Masonry,” in *Masonry: Research, Application and Problems, ASTM STP 871*, ed. J.C. Grogan and J.T. Conway (Philadelphia: American Society for Testing and Materials, 1985), 15.

²³ N. De Vitis, A.W. Page and S.J. Lawrence, “Influence of Age on the Development of Bond Strength,” (paper presented at the 4th Australian Masonry Conference, Sydney, Australia, November 23-24 1995), 1.

²⁴ Ibid.

ages 3 to 365 days using a small-scale uniaxial tension test.²⁵ After 7 days, bond strength generally increased, reaching a maximum strength at 180 days. A decrease in bond strength was observed at 90 days and 365 days and the reasons for these changes were not apparent.²⁶

2.4 Bond Strength of Used Bricks

Based on my research, it appears that the perception that mortar clogs the brick pores and diminishes bond strength originated from a report issued by the Engineering Experiment Station at the University of New Hampshire in 1934. The Brick Industry Association (BIA) refers to the Engineering Experiment Station (EES) as the basis for diminishing bond strength when using salvaged brick in a technical note titled, “Technical Note 15: Salvaged Brick” written in 1988. Many online forums refer to the BIA technical note as the source of the “clogged pore” idea.

The Engineering Experiment Station was formed in 1929 to provide professional engineering and scientific assistance to the construction industry in New Hampshire.²⁷ The report is titled, “Relative Adhesion of Mortars to New and Used Brick” and was conducted for Star Brick Yard in Epping, New Hampshire. The premise of the experiment was to study “the relative adhesion of different standard mortars to new and used or reclaimed brick”²⁸. Four types of new brick were tested in this study: sand struck hard bricks, sand struck soft bricks, water struck hard bricks and water struck soft bricks. Used bricks were also both hard and soft, sand and water struck.²⁹ Adhesion properties were tested on new

²⁵ Heber Sugo, Adrian W. Page and Stephen Lawrence, “Influence of Age on Masonry Bond Strength and Mortar Microstructure,” *Canadian Journal of Civil Engineering* 34, no. 34, 2007: 1433.

²⁶ *Ibid.*, 1441.

²⁷ “Guide to the Engineering Experiment Station Files, 1929-1968,” University of New Hampshire Archives, accessed December 10, 2012, <http://www.izaak.unh.edu/archives/holdings/ua8/ua8-1-1.shtml>.

²⁸ Engineering Experimental Station, “Relative Adhesion of Mortars to New and Used Brick,” (Durham: University of New Hampshire, 1935), 1.

²⁹ *Ibid.*, 1.

and used brick from Star Brick Yard of Epping, New Hampshire and W.S. Goodrich Inc. of Epping New Hampshire.³⁰ The introduction states the premise of my thesis investigation.

It is reasonable to expect that a brick which has been taken from an old wall is covered with dirt, dust, soot, etc. which have been weathered into the microscopic pores of the brick. Furthermore, if the original mortar used with the brick had adhered properly to the brick to provide a good tight joint in the old wall it would continue to adhere to the brick surface after the brick had been removed from the wall. Ordinary cleaning would remove some of the excess old mortar from the surface, but nothing short of a thorough grinding would open up the capillary pores of the brick and produce a surface into which the new mortar could fasten itself.³¹

In the EES experiment, new bricks and used bricks were tested for bond strength using seven different types of mortar. Mortars included Portland cement mortars, Portland cement and lime mortars, and lime mortars in various proportions.³² Used bricks were cleaned of any loose mortar with a hammer and wire brush and the location of foreign material on the surface was documented in a drawing. Brick assemblages were built and cured for 28 days, 60 days and 90 days. At the end of each aging period, the assemblages were broken apart by tension in a testing machine³³.

The report concludes:

1. With exception of two lime mortars at the end of the sixty day period, the bond strength of all mortars to new bricks were as an average about twice as great as those of the same mortars with similar used or reclaimed brick.
2. In the case of hard bricks, whether sand or water struck, the adhesion of any mortar to new bricks was materially greater than that of the same mortar to second hand bricks.
3. In the case of soft bricks, both water and sand struck, the adhesion of the mortar to new bricks was also greater than that of the same mortar to second hand bricks, but the difference was not as marked as in the case of hard brick.
4. With but few exceptions the adhesion of mortar to hard bricks, whether new or second hand, was far greater than that of the same mortar to soft bricks of the same type.

³⁰ Engineering Experimental Station, "Relative Adhesion," 4.

³¹ Ibid., 1.

³² Ibid.

³³ Ibid., 2-6.

5. Those mortars having the highest tensile strength also possessed the greatest bond strength to both new and used bricks.
6. Without exception ... failure of the mortar to adhere to the surface of used brick far exceeded the failures of the joint between mortars and new brick. In other words, it appears that the capillary pores of the second hand brick were so plugged ... that the new mortar could not gain any appreciable hold on the surface of the brick.
7. In the case of new hard bricks, both sand and water struck, the failures in the mortar exceeded by far the failures in the joint between mortar and brick. This would indicate that the adhesive strength of the mortar to the hard brick exceeded its cohesive strength.
8. With used brick, both sand and water struck, and with both hard and soft, the cohesive strength of the mortars exceeded many times the adhesive strength of the same mortars to the surfaces of the brick.

The data obtained in this study shows that within the limits of the test ...the relative adhesion of mortars to used or reclaimed brick, together with their bond strength, are less than half what can be expected if the same mortars were used with new brick of the same type and degree of hardness.³⁴

The conclusions from the EES report should be clarified in relation to this thesis.

The EES experiment is within the bounds of water struck and sand struck bricks, which are two types of molded brick. Secondly, the term “used”, in this study, is more accurately defined as “salvaged”. Although the report aimed to test used bricks with identical physical characteristics, it states that the used brick were obtained from several different sources, with “a majority collected and furnished by Star Brick Yard and W.S. Goodrich”.³⁵ In my opinion, because these bricks are of unknown provenance they more closely meet the definition of salvaged brick, rather than reclaimed brick as I previously defined in this thesis. Conclusions from the EES report should be recognized as results of new molded bricks versus salvaged molded bricks with similar physical properties. This is an important distinction because this study has been used as the basis for not reusing any type of brick in many other publications.

³⁴ Engineering Experimental Station, “Relative Adhesion,” 6-7.

³⁵ Ibid., 2.

2.5 Bond Strength Testing Standards

Currently, the American Society for Testing and Materials publishes four testing standards to measure brick to mortar bond strength.

“ASTM E72 Standard Test Methods of Conducting Strength Tests of Panels for Building Construction” was originally adopted in 1947 and reapproved in 2010.³⁶ This test method evaluates full scale wall specimens. The specimens can be broken by applying a uniformly distributed load or a continuous concentrated load.³⁷ This test method can be very expensive and difficult to conduct because of the large scale of specimens.

“ASTM E518/E518M Standard Test Methods for Flexural Bond Strength of Masonry”³⁸ was adopted in 1974 and most recently reapproved in 2010. It evaluates the flexural bond strength of unreinforced masonry assemblages, but the specimens tested are much smaller than ASTM E72. Two test procedures are detailed, one a simply supported beam with a two-point load and the other a simply supported beam with uniform loading. ASTM E518 is intended to provide simplified and economical means for gathering comparative research data on the flexural bond strength developed with different types of masonry units and mortar or for the purpose of checking job quality control (materials and workmanship).³⁹

³⁶ Brent A. Gabby, “A Compilation of Flexural Bond Stresses for Solid and Hollow Non-Reinforced Clay Masonry and Portland Cement-Lime Mortars,” in *Masonry: Components to Assemblages, ASTM STP 1063*, ed. John H. Matthys (Philadelphia: American Society for Testing and Materials, 1990), 236.

³⁷ American Society for Testing and Materials, “E72-10: Standard Test Methods of Conducting Strength Tests of Panels for Building Construction,” doi:10.1520/E0072-10.

³⁸ American Society for Testing and Materials, “ASTM Standard E518-10: Standard Test Methods for Flexural Bond Strength of Masonry,” doi: 10.1520/E0518_E0518M-10.

³⁹ Ibid.

“ASTM C1072 Standard Test Methods for Measurement of Masonry Flexural Bond Strength”⁴⁰ was adopted in 1986 and most recently reapproved in 2011. This test method was introduced by Hughes and Zmembra in 1980.⁴¹ It evaluates the flexural bond strength normal to the bed joints, of masonry built of manufactured masonry units using the bond wrench test method. The standard provides three methods of testing –the first is for laboratory-prepared specimens, the second for field-prepared specimens and the third for prisms removed from existing masonry.⁴²

“ASTM C952 Standard Test Methods for Bond Strength of Mortar to Masonry Units”⁴³, most recently reapproved in 2012. It evaluates the tensile strength of mortar using a crossed brick couplet test and the flexural strength of mortar in a stacked mortar-concrete block test.⁴⁴

The ASTM standards appear to be based on international standards. EN 1052-5 is the “European standard methods of test for masonry”⁴⁵ which determines bond strength through the use of the bond wrench method. The “Australian Code of Practice, AS 3700” specifies a bond wrench test for the measurement of bond. AS 3700 is based on the strength at an age of 7 days on the assumption that there might not be any significant increase in strength after this time.⁴⁶

⁴⁰ American Society for Testing and Materials, “C1072-11: Standard Test Methods for Measurement of Masonry Flexural Bond Strength,” doi:10.1520/C1072-11.

⁴¹ Gabby, “A Compilation of Flexural Bond Stresses,” 240.

⁴² Ibid.

⁴³ American Society for Testing and Materials, “Standard Test Method for Bond Strength of Mortar to Masonry Unit,” ASTM Standard C952-12, doi: 10.1520/C952-12.

⁴⁴ American Society for Testing and Materials, “Standard Test Method for Bond Strength of Mortar to Masonry Unit,” 1.

⁴⁵ British Standards, “Methods of Test for Masonry: Determination of Bond Strength by the Bond Wrench Method,” EN 1052-5:2005.

⁴⁶ Australian Standards, “Masonry Structures Code,” AS 3700: 2001.

The bond wrench test has been known to produce highly variable results. In 1996, W. Mark McGinley combined testing and analytical investigation of four different bond wrench testing systems.⁴⁷ McGinley determined that the configuration of the specimen clamping mechanism can have a significant effect on the distribution of strain within the specimen.⁴⁸ An alternative test method to measure flexural bond is the four-point beam test. The variability of the bond wrench test and the four-point bend test were measured by H.A. Harris. In his results, the coefficient of variance (COV) for the bond wrench test averaged 25.9% whereas the COV for the four-point bend test averaged 13.0%.⁴⁹

2.6 Building Codes

The design of unreinforced masonry is subject to the *Building Code Requirements for Masonry Structures*⁵⁰. Flexural tensile stresses must satisfy design conditions for the specific type of mortar and brick unit combination. In this thesis, a type N Portland cement/lime mortar was used with a solid brick. According to Table 1, the allowable flexural tensile stress normal to bed joints for this combination is 30 psi.

⁴⁷ W. Mark McGinley, "An Evaluation of Bond Wrench Testing Apparatuses," in *Masonry: Esthetics, Engineering and Economy*, ASTM STP1246 (Philadelphia: American Society for Testing and Materials, 1996), 100.

⁴⁸ Ibid., 115.

⁴⁹ H.A. Harris, "Proposed Revisions to the Masonry Flexural Bond Strength Procedure" (paper presented at the 5th North American Masonry Conference, Urbana-Champaign, Illinois, June 3-6, 1990): 687-700.

⁵⁰ Masonry Standards Joint Committee, "Building Code Requirements for Masonry Structures," ACI 530-05/ASCE 5-05/TMS 402-05.

Table 1 - Allowable flexural tensile stresses for clay and concrete masonry, psi (kPa)⁵¹

Direction of flexural tensile stress and masonry type	Mortar types			
	Portland cement/lime or mortar cement		Masonry cement or air entrained portland cement/lime	
	M or S	N	M or S	N
Normal to bed joints				
Solid units	40 (276)	30 (207)	24 (166)	15 (103)
Hollow units ¹				
UngROUTED	25 (172)	19 (131)	15 (103)	9 (62)
Fully grouted	65 (448)	63 (434)	61 (420)	58 (400)
Parallel to bed joints in running bond				
Solid units	80 (552)	60 (414)	48 (331)	30 (207)
Hollow units				
UngROUTED and partially grouted	50 (345)	38 (262)	30 (207)	19 (131)
Fully grouted	80 (552)	60 (414)	48 (331)	30 (207)
Parallel to bed joints in stack bond	0(0)	0(0)	0(0)	0(0)

¹ For partially grouted masonry, allowable stresses shall be determined on the basis of linear interpolation between fully grouted hollow units and ungrouted hollow units based on amount (percentage) of grouting.

Properties of bond strength have been thoroughly researched and it is well documented that the flexural strength of brick to mortar assemblages is influenced by many inter-related factors. However, it is clear that very little research looks at the use of reclaimed bricks and its properties of bond strength.

⁵¹ Ibid, C-28.

Chapter 3: Design of Experiment

The design of this thesis experiment was developed as a response to a generally accepted practice that bricks should not be reused because the bond between brick to mortar is not durable and to answer the question: does bond strength diminish when bricks are reused? One of the principles of this experiment was to reduce the number of variables. There are numerous factors that affect the flexural bond strength of brick to mortar wall systems and each factor was considered in the design of this experiment.

3.1 Brick

The first variable considered was the brick that was used in the experiment. Physical properties of brick are an important contributor of bond strength.⁵² There are a wide variety of bricks in production today with varying materials, sizes, surface textures and manufacturing processes.

Each manufacturer uses raw materials in unique proportions and fires brick at differing temperatures, producing bricks with various colors, textures, sizes and physical properties.⁵³ Primary raw materials include a combination of surface clays, fire clays and/or shales.⁵⁴ Bricks are then fired in a kiln in temperatures ranging between 1800°F and 2100°F.⁵⁵ There were numerous types of brick produced throughout history including face brick, clinker brick, pressed brick, glazed brick, fire brick and cored brick. Each type of brick is manufactured differently and produces varying physical properties.

⁵² American Society for Testing and Materials, "Standard Specification for Mortar for Unit Masonry," ASTM Standard C270-12, doi:10.1520/C0270-12A, 6.

⁵³ "Brick Masonry Material Properties," *The Brick Industry Association Technical Notes on Brick Construction*, no. 3A (1992): 1.

⁵⁴ Ibid.

⁵⁵ Ibid.

The brick making process also affects bond strength because each process produces distinctive bed surfaces. The handmade method is a soft mixture of clay that is forced through an extruder and cut into slugs. The slugs are then put into a pre-sanded wooden mold and the excess raw material removed by a wire.⁵⁶ The bed surfaces in these bricks differ as one side comes into contact with the mold. Machine-molded bricks are produced similarly to handmade bricks, except that the clay is pushed into wooden molds using a highly pressurized machine. Bed surfaces of machine-molded bricks differ on each side. Extruded bricks are made with stiff mud with only enough water for the clay to be extruded through a die into a long ribbon and cut using wires.⁵⁷ The bed surfaces of extruded bricks are similar to each other. Soft-mud bricks are produced using a wet clay mixture that is pressed into molds.⁵⁸ The bed surfaces in these bricks also differ as one side comes into contact with the mold and the other is compressed by a pressurized mechanism.

It has been established by previous studies that bond is affected by the initial rate of absorption properties of brick.⁵⁹ The pores in clay products draw water into the bricks through capillary uptake.⁶⁰ Long-term absorption properties are also important because the bonding of mortar and brick takes place through an extended period of time, particularly with mortars that include lime components. Brick bed surfaces come into contact with wet mortar where initial capillary uptake and long-term absorption of water takes place. IRA and

⁵⁶ "The Making Process," Glen-Gery Brick, accessed March 14, 2013, <http://www.glengerybrick.com/about/manufacturing/making.html>

⁵⁷ Susan Begley Broeksmit and Anne T. Sullivan, "Dry-Press Brick: A Nineteenth-Century Innovation in Building Technology," *APT Bulletin* 37, no.1, (2006): 45.

⁵⁸ *Ibid.*, 44.

⁵⁹ William G. Bailey, John H. Matthys and Joseph E. Edwards, "Initial Rate of Absorption of Clay Brick Considering Both Bed Surfaces in the as Received Condition and After Outside Exposure," in *Masonry: Components to Assemblages, ASTM STP 1063*, ed. John H. Matthys (Philadelphia: American Society for Testing and Materials, 1990), 20.

⁶⁰ *Ibid.*, 6.

absorption properties are affected by the raw materials, the method of production and the firing temperature in the manufacturing process used to make brick.⁶¹

Other specifications, such as the compressive strength, boiling water absorption and the cold water to boiling water absorption ratio were not considered in this experiment because it has been determined by others that these specifications do not affect bond strength.⁶²

For this experiment a solid, extruded brick was selected.

3.2 Mortar

The second variable considered was the type of mortar to be used in this experiment. Studies show that the material components that make up a mortar mixture are a major factor in the strength of bond.⁶³ Plastic properties of mortar determine a mortar's construction suitability through its workability and water retentivity, which in turn also affect bond.⁶⁴

Four general mortars are typically used in today's masonry construction: Portland cement-lime, masonry cement, mortar cement and lime mortar.⁶⁵ Portland cement-lime is composed of hydrated lime and Portland cement in various proportions. Portland cement-lime mortars provide high strength and early setting characteristics of cement modified by workability and water retentivity of lime.⁶⁶ "ASTM C270 Standard Specification for Mortar for Unit Masonry"⁶⁷ specifies Portland cement-lime mortars to be mixed to Type M, S, N

⁶¹ Ritchie and Davison, "Factors Affecting Bond Strength," 19.

⁶² Kamf, "Factors Affecting Bond of Mortar to Brick," 132.

⁶³ Bruce T. Wright, Rick D. Wilkins and George W. John, "Variables Affecting the Strength of Masonry Mortars," in *Masonry: Design and Construction, Problems & Repair, STP 1180*, ed. John M. Melander and Lynn R. Lauersdorf (Philadelphia: American Society for Testing and Materials, 1993), 197.

⁶⁴ American Society for Testing and Materials, "ASTM Standard C270," 6.

⁶⁵ Ibid.

⁶⁶ Ibid., 10.

⁶⁷ American Society for Testing and Materials, "ASTM C270-12."

and O portions for different uses. These four types correspond to proportional specifications and property specifications of mortar leading to compressive strength, water retention and air content.⁶⁸ Masonry cement mortar is comprised of Portland or hydraulic cement, plasticizing material (such as limestone, hydrated or hydraulic lime) and other ingredients to enhance setting time, workability, water retention and durability.⁶⁹ Masonry cement is widely used because of its convenience and good workability and excellent freeze-thaw durability.⁷⁰ Mortar cement is composed of the same materials as masonry cement, except that specification requires lower air content and includes a flexural bond strength requirement.⁷¹ Lime mortars are composed primarily of hydrated lime which sets through carbonation. Lime mortars set slowly and are highly plastic, allowing greater workability, water retention and elasticity.⁷² Aggregates such as sand added to any of the four mortars described provide important bond characteristics because they control shrinkage and color.⁷³

Workability is another important property of plastic mortar because it determines how easily mortar can be spread onto a masonry unit and support the weight of units as they are laid on top of one another.⁷⁴ Workability is largely dependent on water content. The capacity of a mortar to retain adequate workability under the impact of surface suction and evaporation rate depends on the water retentively and setting characteristics of the mortar.⁷⁵

⁶⁸ American Society for Testing and Materials, "ASTM C270-12," 3.

⁶⁹ American Society for Testing and Materials, "ASTM C91: Standard Specification for Masonry Cement," doi:10.1520/C0091-12.

⁷⁰ "Mortars for Brickwork," *The Brick Industry Association Technical Notes on Brick Construction*, no. 8 (2008): 2.

⁷¹ American Society for Testing and Materials, "ASTM C1329-12: Standard Specification for Mortar Cement," doi: 10.1520/C1329_C1329M-12.

⁷² U.S. Department of the Interior, *The Preservation of Historic Architecture* (Guilford: The Lyons Press, 2004), 21.

⁷³ "Mortars for Brickwork," 3.

⁷⁴ American Society for Testing and Materials, "ASTM C270-12," 6.

⁷⁵ Ibid.

Water retention is “a measure of the ability of a mortar under suction to retain its mixing water”.⁷⁶ This mortar property gives the mason time to place and adjust a brick without the mortar stiffening.⁷⁷

For this experiment, a pre-packaged Type N Portland cement-lime mortar was selected.

3.3 Construction Techniques

The third variable considered was which construction techniques to use when building the sample prisms. The construction methods in which bricks and mortar are laid together have an enormous impact in the way the two components bond.⁷⁸ Factors connected to construction techniques include, wetting of brick before assembly, the length of time that elapses between laying a bed of mortar and placing bricks, the way a brick is set into mortar, the retempering of mortar and the thickness of the mortar bed.

Wetting of bricks before they are laid is a common construction practice. Wetting of bricks can improve bonding properties if bricks have a high suction rate.⁷⁹ This practice also makes it easier to set bricks in place in the mortar. Research has shown that bricks with an initial rate of absorption of 30 g/min/30 in² or higher should be wet before use.⁸⁰

The time between spreading a mortar bed and placing a brick on top can also affect bond strength.⁸¹ The study by Richie and Davison concluded that as the time interval

⁷⁶ American Society for Testing and Materials, “ASTM C270-12,” 7.

⁷⁷ Ibid.

⁷⁸ Richie and Davison, “Factors Affecting Bond Strength,” 24.

⁷⁹ Ibid, 21.

⁸⁰ A.H. Yorkdale, “Initial Rate of Absorption and Mortar Blend” in *Masonry: Materials, Properties and Performance*, ASTM STP 778, ed. J.G. Borchelt (Philadelphia: American Society for Testing and Materials, 1982), 91.

⁸¹ Richie and Davison, “Factors Affecting Bond Strength,” 24.

increased, the strength of bond decreased.⁸² The importance of time was dependent on the particular combination of brick and mortar used.⁸³

Different methods of laying brick have an influence on bond strength. When a bricklayer places a brick on a bed of mortar, he may tap it with his trowel to bring it to line.⁸⁴ Other bricklayers may not use the tapping method, and instead shove the brick into place and adding hand pressure.⁸⁵ In laboratory conditions, a drop hammer can be used to add consistent pressure to a joint.⁸⁶

There is a limited amount of time between when the mortar is mixed and when the mortar is placed in the wall. As it starts to dry out and set, the plasticity of the mortar changes. Retempering is when water is added to the mortar to restore workability.⁸⁷ Changes in bond strength have been demonstrated in the study by T. Richie and J.I. Davison titled, “Factors Affecting Bond Strength and Resistance to Moisture Penetration of Brick Masonry”. The study states that “change in bond strength with increasing time interval before retempering ranged from a value well over 40 psi for mortar used immediately after mixing to a value of about 20 psi for mortar retempered 4 hours after mixing”.⁸⁸

The thickness of the mortar bed influences bond strength. Generally within limits, joints that are thicker exhibit higher bond strength.⁸⁹ However, because mortar shrinks as it

⁸² Ibid.

⁸³ Ibid.

⁸⁴ Ibid., 26.

⁸⁵ Ibid.

⁸⁶ ASTM C1072.

⁸⁷ SSakir Erdog̃du, “Effect of retempering with superplasticizer admixtures on slump loss and compressive strength of concrete subjected to prolonged mixing,” *Cement and Concrete Research* 35, no. 5 (2005): 907.

⁸⁸ Richie and Davison, “Factors Affecting Bond Strength,” 28.

⁸⁹ Ibid.

dries, if the joint is too thick, more shrinkage can occur and thus lowering bond strength.⁹⁰

ASCE 6-92 “Specification for Masonry Structures”⁹¹ indicates that mortar bed joints should be constructed 3/8 in., except at foundations.⁹²

Tooling of the mortar joint is also a factor that contributes to bond strength. Tooling can help “seal the interface between the mortar and masonry unit, while densifying the surface of the mortar joint.”⁹³

Sample preparation took place at the International Masonry Institute (IMI), located in Queens, New York. The IMI provides professional education for masonry contractors, training for craft workers and technical support to the design and construction communities.⁹⁴ In this experiment, construction techniques were left to the discretion of the IMI mason. However, the same mason was used to build all samples to maintain consistency.

3.4 Curing Conditions

The aging of prisms greatly affects bond strength. As shown in Figure 1, specimens that cured between 1 and 90 days increased in bond strength.

⁹⁰ M. Zhu and D.D.L. Chung, “Improving Brick-to-Mortar Bond Strength by the Addition of Carbon Fibers to the Mortar”, *Cement and Concrete Research* 27, no. 12 (1997): 1829.

⁹¹ Masonry Standards Joint Committee “Specification for Masonry Structures”.

⁹² Ibid, S-11.

⁹³ American Society for Testing and Materials, “ASTM C270-12,” 7.

⁹⁴ “IMI Mission,” International Masonry Institute, accessed March 20, 2013, <http://www.imiweb.org/about/mission.php>.

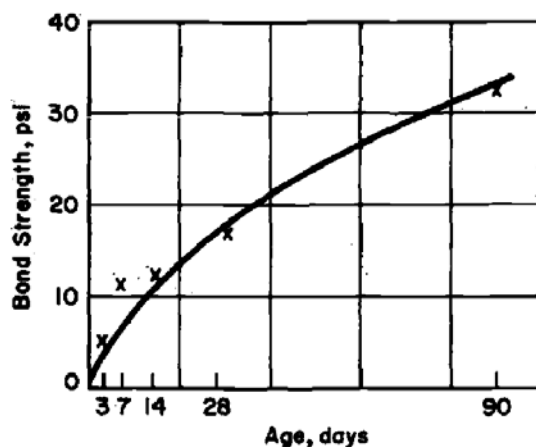

Figure 1 - Effect of Age on Bond Strength⁹⁵

The temperature at which sample prisms cure can lead to volumetric changes in mortars.⁹⁶ Change in temperature will lead to expansion or contraction of mortar. Mortar swells as its moisture content increases and shrinks as it decreases.

For this experiment, samples were cured for 7 days indoors.

3.5 Cleaning

Cleaning used brick units is not a standard practice in the construction industry. However, there are multiple technical guides and cleaning manuals for cleaning new brickwork, such as the Brick Industry Association's Cleaning Brickwork Technical Note⁹⁷ and Think Brick Australia's Brick Cleaning Manual⁹⁸. These technical manuals address cleaning of brickwork as methods for the removal of efflorescence, stains and mortar residue. Methods of cleaning mortar residue were only consulted in the study because the removal of efflorescence and stains are beyond the scope of this experiment.

⁹⁵ Leo Kampf, "Effect of Age on Bond Strength," in *Symposium on Masonry Testing, ASTM STP 320* (Philadelphia: American Society for Testing and Materials, 1963): 139, figure 11.

⁹⁶ "Mortars for Brickwork," 9.

⁹⁷ "Cleaning Brickwork," *The Brick Industry Association Technical Note on Brick Construction*, no. 20 (2006).

⁹⁸ "The Brick Cleaning Manual," *Think Brick Australia* (2008), accessed February 1, 2013, http://www.thinkbrick.com.au/assets/documents/technical_information/brickwork/TBR4978Cleaning-Masonry2HR1.pdf.

Cleaning of brickwork can be done by hand or with the assistance of power tools. Hammer and chisel hand cleaning technique is a simple cleaning method which consists of hitting loose bits of mortar from the surface of the brick. Bucket and brush hand cleaning consists of soaking bricks in water and using a wire brush to remove excess mortar. Chemical hand cleaning techniques include applying liquid detergents to the surface of bricks and using a brush to clean off excess mortar. Acid wash cleaning involves the use of diluted muriatic acid to remove excess mortar. Pressurized water cleaning is a less labor intensive method. This cleaning procedure utilizes pressurized water and requires more skill because consistent results depend on maintaining a consistent pressure, water flow, distance and angle from bricks.⁹⁹

For this experiment, three cleaning methods were selected as the primary variable being tested. The three common cleaning techniques chosen for this experiment were the tap-off method, wire brush cleaning and acid wash cleaning. Each cleaning stage attempted to raise the amount of disruption of bonded mortar residue on the surface of the brick in order to loosen any clogged pores. After speaking to multiple masonry instructors at the IMI, it was determined by the author that the tap-off method, brush cleaning and acid wash cleaning would provide for three distinctly different surface textures.

3.6 Measurement of Bond Strength

There are many different test procedures to measure bond strength. The flexural bond strength of masonry is particularly crucial in the design of masonry walls because of lateral forces, such as wind loads, seismic loads, or vibrations applied perpendicular to the face of the wall. Compressive bond strength helps brick walls resist vertical loads, such as

⁹⁹ "Cleaning Brickwork," 5.

roof and floor loads. Tensile bond strength withstands stretching forces and contributes to flexural strength. Shear strength of a masonry unit wall resists vertical and lateral loads in-plane.

Testing methods for flexural bond strength include ASTM C1072 and ASTM E518. Testing methods for tensile bond strength include ASTM C952. Testing method for shear include “ASTM E519 Standard Test Method for Diagonal Tension (Shear) in Masonry Assemblages”¹⁰⁰. There are no standard testing methods to measure compressive bond strength. Previous compressive strength tests of assemblages follow sample preparations provided in flexural bond testing standards and adhere to testing procedures in “ASTM C67 Standard Test Method for Sampling and Testing Brick”.¹⁰¹

Since the flexural-bond capacity of masonry is typically very low, it represents a critical weak link in the string of parameters affecting durability. Tensile and compressive strengths far exceed the flexural bond strength between mortar and masonry.¹⁰² In this thesis, the crossed brick couplet was not tested because it measures the direct tensile strength of the bond. It is less applicable in free-standing walls that are subject to large amounts of wind load. Flexural bond strength measured using the bond wrench test and four-point bending test was deemed more applicable because it accounts for forces perpendicular to the wall. Two testing procedures were performed in an effort to observe patterns of changes in bond strength.

¹⁰⁰ American Society for Testing and Materials, “ASTM E519-10: Standard Test Method for Diagonal Tension (Shear) in Masonry Assemblages,” doi:10.1520/E0519_E0519M-10.

¹⁰¹ G. Sarangapani, B.V. Venkatarama Reddy and K.S. Jagadish, “Brick-Mortar Bond and Masonry Compressive Strength,” *Journal of Materials in Civil Engineering* 17, no. 2 (2005): 232.

¹⁰² American Society for Testing and Materials, “ASTM C1072-11,” 7.

Chapter 4: Test Program

The principle objectives of this test program were to

1. experimentally determine if there is a change in bond strength when reusing brick;
2. experimentally observe the change in surface texture of brick when reapplying mortar;
3. experimentally test the change in brick surface suction and absorption qualities when using reclaimed brick.

4.1 Brick

Sample prisms were designed and constructed based on the guidelines of ASTM C1072 standards with some modifications. Construction of sample prisms replicated “real world” conditions in which masons would encounter on a typical jobsite.

The first set of prisms was built using a machine-molded brick did not bond properly due to unknown circumstances (see Appendix for further information). New prisms were constructed using a different brick (Watson town Atlantic Series Extruded Sanded Smooth facing brick). An extruded brick was chosen because it features similar textures on both bedding surfaces. The Watson town Atlantic Series bricks were specifically chosen because they were available on site at the International Masonry Institute and in light of the reduced time frame resulting from the failure of the initial prism sets.

Standard solid sized bricks were used in the construction of prisms. Physical properties were based on the mean value of five tests conducted by the author in the Columbia University laboratory.

Table 2 - Physical Properties of Bricks

Dry mass (g)	Dimensions (in x in x in)	Volume (in ³)
2274.86	2 ¼ x 3 ½ x 8	63.0

Based on mean value of 5 tests

Watson town Brick Company's website indicates that the Atlantic Series bricks "are produced by melding the finest sand on a smooth die skin body"¹⁰³. The Atlantic Series, which is appropriate for commercial and residential projects, is "manufactured in a state-of-the-art extrusion plant and fired in our high temperature kiln to meet all FBX requirements."¹⁰⁴ The "sanded smooth" texture is "achieved by applying a very even sand coating to the smooth, extruded die skin."¹⁰⁵



Figure 2 - Photos of standard Watson town Brick Used in Experiment

Since the clogging of pores was identified as a significant contributor to poor bond strength in the 1934 "Relative Adhesion of Mortars to New and Used Brick" publication, the main area of this thesis was the surface pores on the brick bedding surfaces. Visual examination of the pores was essential to understand whether the pores were clogged and to what extent they were clogged. The initial rate of absorption, cold water submersion properties and visual examination of pores were measured by the author.

¹⁰³ "Product Lines: Atlantic Series" Watson town Brick Company, accessed April 27, 2013, <http://www.watson town brick.com/product-lines/Atlantic-Series-Brick>.

¹⁰⁴ Ibid.

¹⁰⁵ Ibid.

The absorption qualities of the masonry units are an important factor in brick-to-mortar bond. Bricks have a porous structure and extract water from mortar when they come into contact with one another.¹⁰⁶ The suction (initial rate of absorption) exerted by a brick initiates early bond development.¹⁰⁷ ASTM C270 indicates that mortar generally bonds best to masonry units having an initial rate of absorption between 5 to 25 g/min/30in².¹⁰⁸ The IRA is important because if too much or too little water is extracted from the mortar, a well formed bond cannot develop. Pre-wetting bricks lowers the rate of suction. However, there is no practical way to raise the rate of suction.¹⁰⁹

4.2 Mortar

Although many different mortar mixes are used on construction sites, a single mortar mixture was selected to keep test variables to a minimum. Glen-Gery Color Mortar Blend “No Color” was chosen because it complies with ASTM C270 Type N mortar by physical and proportion requirements and is recommended for use when building parapets (see Table 3).

Table 3 - Guide to the Selection of Masonry Mortars¹¹⁰

Location	Building Segment	Mortar Type	
		Recommended	Alternative
Exterior, above grade	load-bearing wall	N	S or M
	non-load bearing wall	O ^B	N or S
	parapet wall	N	S
Exterior, at or below grade	foundation wall, retaining wall, manholes, sewers, pavements, walks, and patios	S ^C	M or N ^C
Interior	load-bearing wall	N	S or M
	non-bearing partitions	O	N
Interior or Exterior	tuck pointing	see Appendix X3	see Appendix X3

¹⁰⁶ American Society for Testing and Materials, “ASTM C270-12,” 6-7.

¹⁰⁷ Ibid.

¹⁰⁸ Ibid.

¹⁰⁹ Ibid.

¹¹⁰ American Society for Testing and Materials, “ASTM C270-12,” 11.

Portland cement mortar gives a high compressive strength and low water retention, but is vulnerable to cracking. A hydrated lime mortar gives a low compressive strength and high water retention, but is vulnerable in its early curing stages.¹¹¹ Glen-Gery Color Mortar Blend combines important characteristics of these two primary components. The Portland cement cures quickly and provides initial strength, while the lime allows for better workability and long term curing.¹¹²

The predictability of uniform results from a pre-blended mixture was an important aspect in its selection, in part to compensate for variability inherent in workmanship in the construction of prisms.



*Figure 3 - Glen-Gery Color Mortar Blend Bag*¹¹³

Glen-Gery Color Mortar Blend is a “pre-colored blend of Portland Cement conforming to ASTM C150 and Type S Hydrated Lime conforming to ASTM C207 with Metallic Oxide Pigments conforming to ASTM C979.”¹¹⁴ Portland Cement-lime mortars made with one bag of Glen-Gery Color Mortar Blend and three cubic feet of sand conform to ASTM C270 Type N by physical and proportion requirements, ASTM C270 Type S by physical requirements only and BIA MI Type N by physical and proportion requirements.

¹¹¹ Ibid.

¹¹² Ibid.

¹¹³ “Glen-Gery Color Mortar Blend Specification Sheet,” Glen-Gery Brick, accessed March 14, 2013, <http://www.glengerybrick.com/pdf/4p1.pdf>.

¹¹⁴ Ibid.

Table 5 provides specification requirements for Glen-Gery Color Mortar Blend standard mix and rich mix, BIA MI Type N, ASTM C270 Type N and ASTM C270 Type S.

Table 4 - Glen-Gery Color Mortar Blend Specification Sheet¹¹⁵

Specification Requirements*					
	GLEN-GERY COLOR MORTAR BLEND		BIA MI Type N	ASTM C270 Type N	ASTM C270 Type S
	Std. Mix	Rich Mix			
Proportion Requirements					
- Portland Cement	-	-	1	1	1
- Hydrated Lime	-	-	1	1	1/2
- G-G Color Mortar Blend	1	1	-	-	-
- Damp Loose Sand**	3	2 1/2	6	6	4 1/2
			AND	OR	OR
Physical Requirements					
- 7 Day Compressive Strength	1600	-	450 min.	-	-
- 28 Day Compressive Strength	2000	-	750 min.	750 min.	1800 min.
- Water Retentivity	90%	90%	70% min.	75% min.	75% min.
- Air Content	6%	6%	12% max.	14% max.***	14% max.***

* Tests were conducted using mixes without color pigments.

** 2 1/4 - 3 times the total volume of cementitious materials is added as sand. Both Portland cement and lime are cementitious materials.

*** For masonry cements, ASTM C270 allows 22% air content.

Following Glen-Gery Color Mortar Blend specification requirements, mortar was mixed using the “Standard Mix” specifications (1 part Glen-Gery Color Mortar Blend and 3 parts damp, loose sand).

4.3 Construction Techniques

Workmanship has a considerable effect on strength and extent of bond.¹¹⁶ It is important to keep to a minimum the time between spreading mortar onto a masonry unit and placing another masonry unit on top. Therefore, a single experienced mason was chosen to build all sample prisms to reduce variability in workmanship. Each prism was constructed

¹¹⁵ “Glen-Gery Color Mortar Blend Specification Sheet.”

¹¹⁶ American Society for Testing and Materials, “ASTM C270-12,” 7.

in the same manner and bed joints were measured for consistency. The construction of prisms took place at the International Masonry Institute.

Although the initial rate of absorption of test bricks did not exceed 30 g/min/30in², bricks were wetted before laying because of common practices in the construction industry.



Figure 4 - Mason Constructing Sample Prisms

4.4 Curing Conditions

ASTM C1072 indicates Portland-cement mortar specimens to cure for 28 days in sealed plastic bags. ASTM E518 indicates hydrated lime specimens to cure in open air for 28 days before testing. Due to time constraints, sample prisms were only cured for seven days. It was determined by the author that a seven day cure would bond to an acceptable strength because the expected 7-day compressive strength of the Glen-Gery Color Blend Mortar reaches 1600psi, approximately 80% of its 28-day compressive strength.¹¹⁷

¹¹⁷ "Glen-Gery Color Mortar Blend Specification Sheet."

Glen-Gery Color Blend Mortar contains both Portland cement and hydraulic lime. All prisms were cured in sealed plastic bags for forty-eight hours to assist in the curing of the mortar.¹¹⁸ This was followed by curing in open air for five days. Lime (calcium hydroxide) cures by carbonation. It absorbs carbon dioxide primarily from the air, converting itself to calcium carbonate.¹¹⁹ If lime mortar dries too quickly, carbonation of the mortar will be reduced, resulting in poor adhesion and poor durability.¹²⁰



Figure 5 - Samples Curing in Sealed Plastic Bags for Initial 48 Hours

After considerable research, I discovered that there was no bond wrench testing apparatus in the New York City metropolitan area. Once I determined there was a bond wrench testing apparatus at the laboratory of Simpson, Gumpertz and Heger (SGH) Engineering in Waltham, Massachusetts, I determined that samples would be created and stored at the International Masonry Institute in Queens, New York then transported by

¹¹⁹ Robert C. Mack and John P. Speweik, *Preservation Brief 2: Repointing Mortar Joints in Historic Masonry Buildings* (Washington D.C.: Cultural Resources, National Park Service, U.S. Department of the Interior, 1998), 5.

¹²⁰ *Ibid.*

personal vehicle to the SGH lab for testing. After the prisms were tested, bricks were transported back to the IMI for cleaning and other physical tests.

4.5 Cleaning

To determine if there were any changes in surface texture/ pore structure in brick after mortar was applied, bricks were cleaned of mortar residue after the initial testing. Three increasingly aggressive stages of cleaning were chosen for testing. The level of residue on the brick and in the pores was determined by visual examination under a microscope. Cleaning was performed by the author at the International Masonry Institute.

Stage 2 brush cleaning was performed using a dense brass bristle brush. In order to perform Stage 3 acid cleaning, the author purchased Crown Gallon Muriatic Acid at a local hardware store. The Material Safety Data Sheet (MSDS) for this product indicates that it contains 25-35% hydrochloric acid and 65-75% water.¹²¹ Crown Muriatic Acid was chosen because it is a common acid available for purchase by masons in many hardware stores. The concentration of hydrochloric acid is similar to those recommended in brick cleaning manuals.

4.6 Measurement of Bond Strength

4.6.1 Bond Wrench Apparatus

The ASTM C1072 standard is a method to measure the bond strength between mortar and masonry unit by using a bond-wrench test. This test method is for evaluating

¹²¹ "Crown Muriatic Acid Material Safety Data Sheet," Packaging Service Co., Inc., accessed March 30, 2013. http://whatsinproducts.com/files/brands_pdf/9114_16025016%20MSDS%20Muriatic%20Acid.pdf

the flexural bond strength (under given conditions) of masonry built of standard masonry units.¹²²

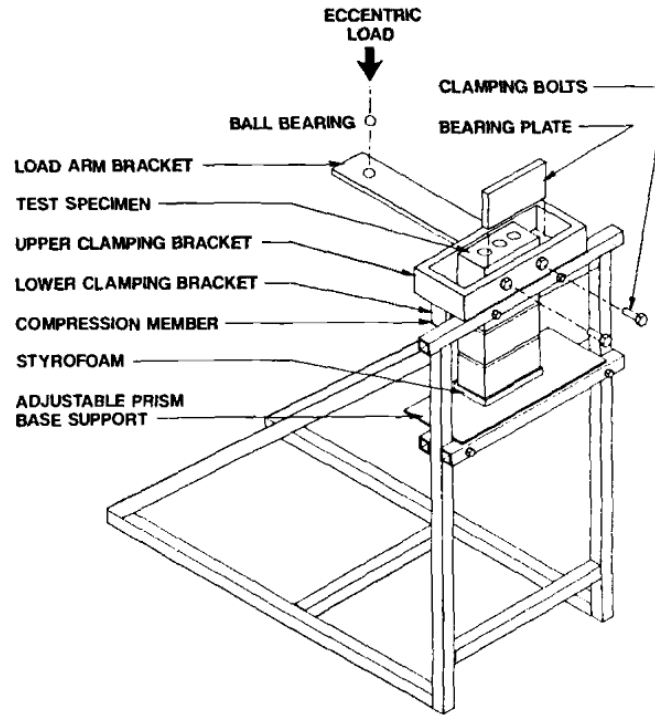

Figure 6 - Bond Wrench Testing Apparatus¹²³

The bond wrench apparatus was provided by the Simpson, Gumpertz & Heger Engineering lab in Waltham, Massachusetts. The bond wrench testing apparatus was secured within the MTS® testing frame. Eccentric loading was applied by the frame using a load cell (see Figure 6). Load was driven and recorded by a computer controlled closed loop.

¹²² American Society for Testing and Materials, "ASTM C270-12," 2.

¹²³ Andrew T. Krauklis, "Bond Wrench set-up ASTM C 1072," *Masonry: Design and Construction, Problems & Repair*, STP 1180, (Philadelphia: American Society for Testing and Materials, 1993): 125, figure 2.

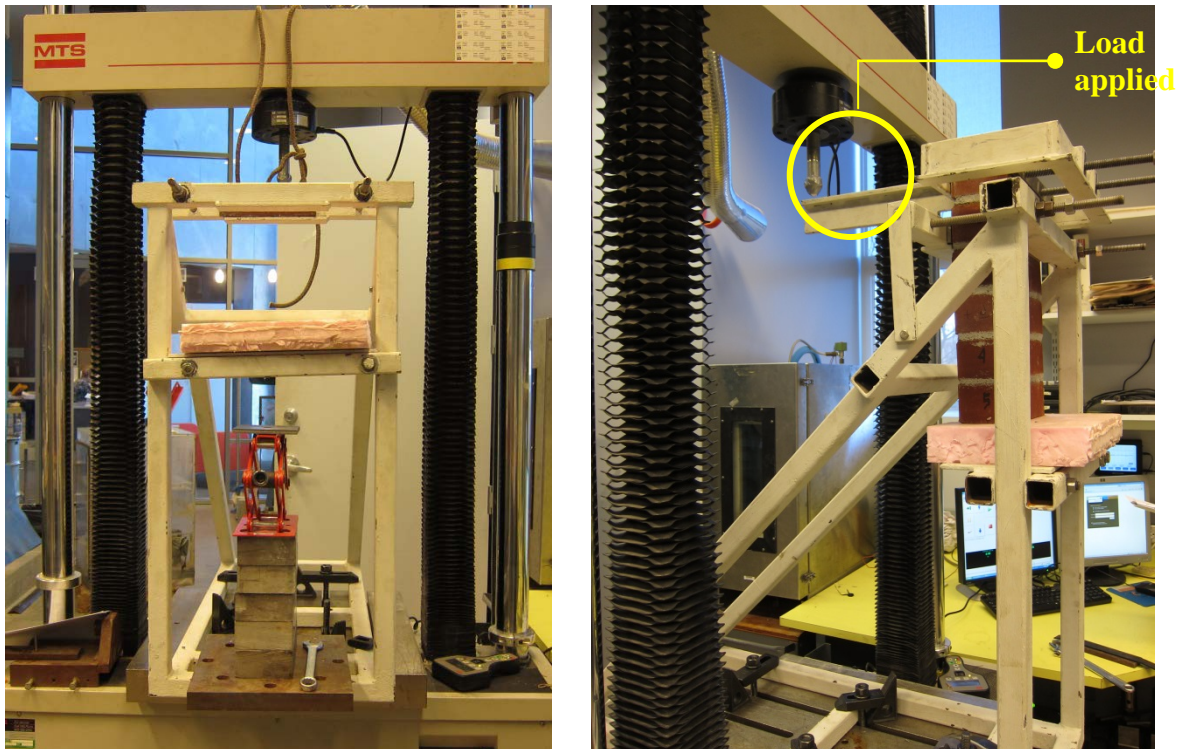

Figure 7 - Bond Wrench Testing Apparatus Secured within MTS Testing Machine

The bond wrench apparatus uses a lever to create a moment in a specific mortar joint. The mortar-unit bond fails at the location of maximum tensile stress (see Figure 8).

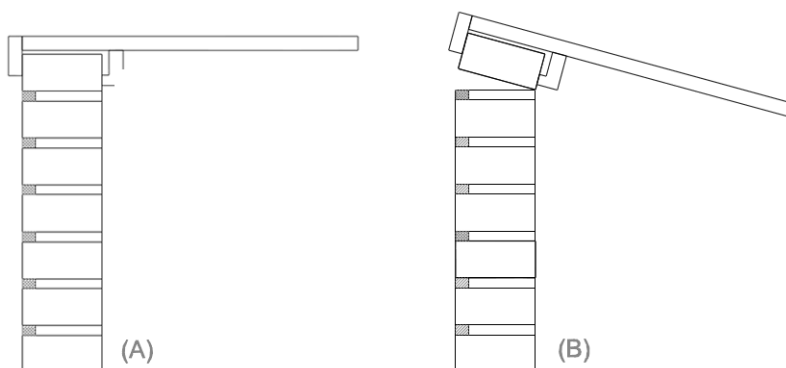

Figure 8 - Basic principle of bond wrench test (a) before and (b) after loading¹²⁴

¹²⁴ L. Binda et al., “Basic Principle of Bond Wrench Test (A) Before and (B) After Loading,” *Characterisation of Old Mortars with Respect to their Repair*, RIBEM TC 167-COM (Bagnoux: RILEM Publications SARL, 2004): 9, figure 3.

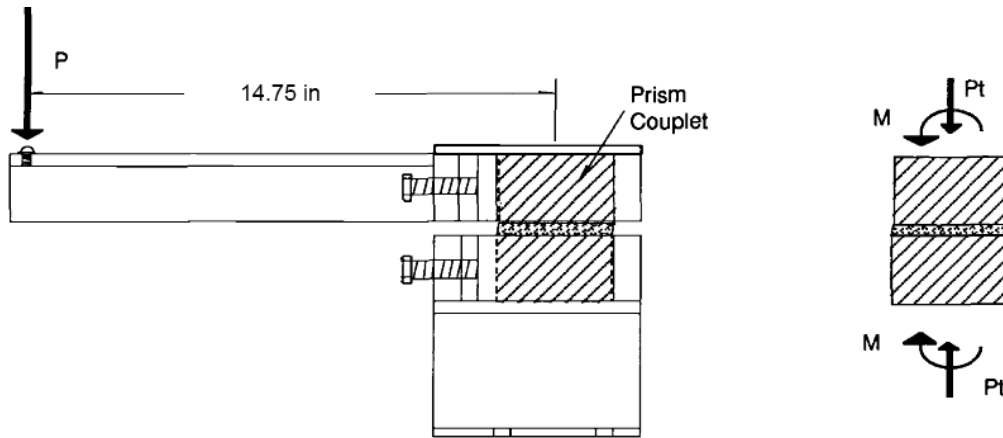

Figure 9 - Free Body Diagram of the Mortar-Unit Interface Under Testing Conditions¹²⁵

Figure 9 shows a free body diagram of the mortar-unit interface under testing conditions. The moment in the mortar joint is equal to the load P times the distance to the center of the brick plus the weight of the lever arm times its distance to the center of the brick. The stress state of the mortar joint can be calculated by combining the stress from the bending moment and the axial stress due to the load, weight of the lever arm and weight of a brick. For specimens built of solid masonry units, the gross area flexural strength was calculated as follows:

$$F_g = \frac{6(PL + P_l L_l)}{bd^2} + \frac{(P + P_l)}{bd}$$

where:

- F_g = gross area flexural tensile strength, psi
- P = maximum applied load, lbf
- P_l = weight of loading arm, lbf
- L = distance from center of prism to loading point, in.
- L_l = distance from center of prism to centroid of loading arm, in.
- b = cross-sectional width of the mortar-bedded area, measured perpendicular to the loading arm of the upper clamping bracket as determined, in.

¹²⁵ Mark W. McGinley, "Lab Wrench Apparatus," *Masonry: Esthetics, Engineering and Economy*, ASTM STP 1246 (Philadelphia: American Society for Testing and Materials, 1996): 103, figure 3.

d = cross-sectional depth of the mortar-bedded area, measured parallel to the loading arm of the upper clamping bracket as determined, in.

4.6.2 Four-point Bend Apparatus

The ASTM E518 standard is a method to measure the bond strength between mortar and masonry unit using a four-point bending test.

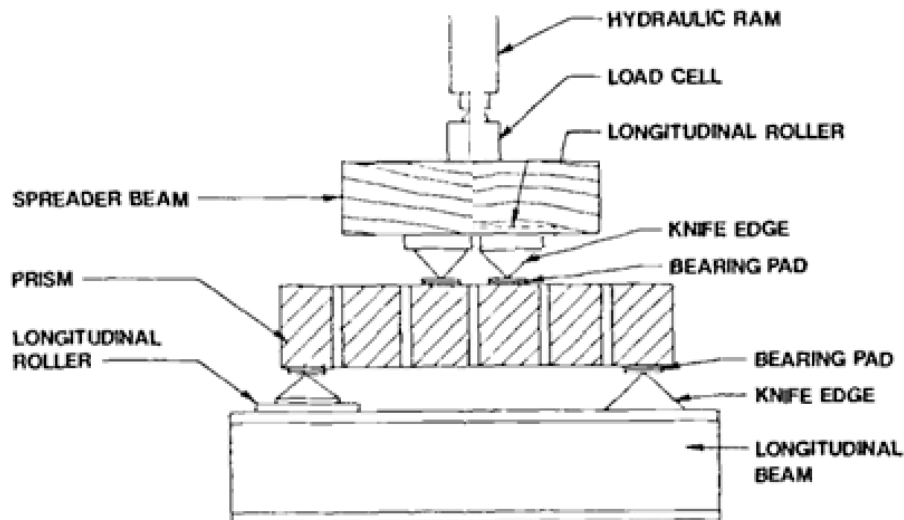

Figure 10 - ASTM E518 Flexural strength test set up¹²⁶

In a four-point bending test, a uniform maximum moment and an area of tension at the bottom of the specimen is achieved (see Figure 10).

¹²⁶ Andrew T. Krauklis, "Flexural test set-up ASTM E 518," *Masonry: Design and Construction, Problems & Repair, STP 1180*, (Philadelphia: American Society for Testing and Materials, 1993): 125, figure 1.

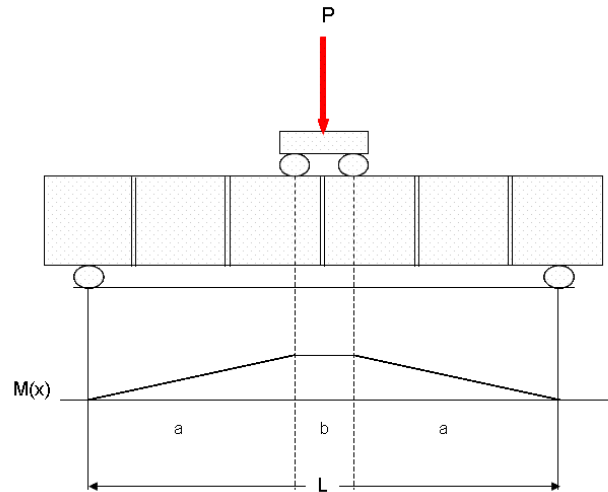

Figure 11 - Moment Diagram for Four-point Bending Test¹²⁷

Figure 11 shows a free body diagram of the sample prism under testing conditions. The greatest moment is found at the center of the prism and therefore the stress at midspan is calculated as follows:

$$R = \frac{3(l - a)P}{2bd^2}$$

where:

- R = gross area modulus of rupture, psi
- P = maximum applied load indicated by the testing machine, lbf
- P_s = weight of specimen, lbf
- l = span, in.
- b = average width of specimen, in.
- d = average depth of specimen, in.

¹²⁷ The Masonry Society, "Basic test setup for the four-point bending test," *Masonry Laboratory Website*, accessed March 23, 2013, <http://www.masonrysociety.org/masonry%20lab/Lab%203/Lab-3-four%20point.html>

Chapter 5: Results

Preliminary material tests were performed by the author in the Conservation Lab at Columbia University. The brick prisms were constructed by a single experienced bricklaying instructor at the IMI to hold consistency in workmanship and match mason techniques commonly used in the field. Flexure testing was conducted in the laboratory of Simpson, Gumpertz and Heger (SGH) in Waltham, Massachusetts. SGH is an engineering firm that designs, investigates and rehabilitates structures.¹²⁸ SGH operates a fully equipped structural testing and materials characterization facility that provides laboratory and field testing. The laboratory is staffed by engineers, scientists, and experienced technicians who actively develop standards and test methods for AWWA, ASTM, AASHTO, ACI, and ASCE.¹²⁹

5.1. Testing

5.1.1 Physical Properties

Preliminary tests were conducted at Columbia University's conservation laboratory by the author. Physical properties were determined in accordance with ASTM C67.

All bricks were individually labeled using a Sharpie® permanent marker. Five brick specimens were measured using a standard United States customary unit system. Dry brick specimens were weighed on the Satorius 4200S scale and recorded (see Figure 12).

¹²⁸ "Who We Are," Simpson, Gumpertz & Heger, accessed March 20, 2013, <http://www.sgh.com/who-we-are/>

¹²⁹ "Field & Laboratory Testing," Simpson, Gumpertz & Heger, accessed March 20, 2013, <http://www.sgh.com/what-we-do/supporting-capabilities/field-laboratory-testing/>

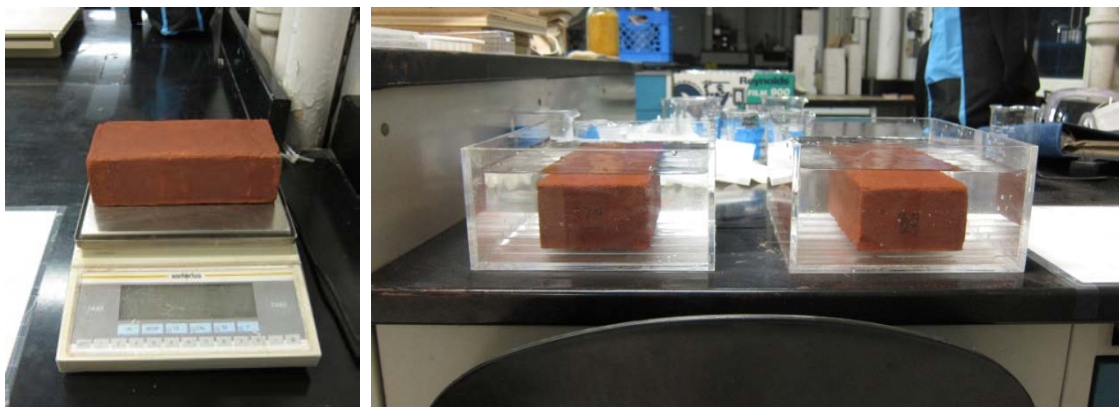

Figure 12 - Weighing of Samples
Figure 13 - Water Absorption Tests

Absorption tests were conducted using plastic containers provided by the Columbia University laboratory. For submersion tests, full bricks were completely submerged in distilled water in the plastic containers (see Figure 13). Measurements were recorded after one minute, five minutes, ten minutes, one hour, five hours and twenty-four hours. Initial rate of absorption tests were conducted using the same plastic containers. Dry bricks were placed inside plastic containers with $1/8 \pm 0.01$ inches of water above the top of the supports. After one minute, the brick was lifted from contact with the water, the surface was wiped with a damp cloth and the brick weighed.

Brick surface pore structure was photographed using a Bausch + Lomb Stereozoom 10x microscope. Sixteen bricks were marked with two rectangles, measuring $1/2$ in. by $1/3$ in. using a marker. Each side of the brick was placed under the microscope to document initial pore structure on the surface of the brick (see Figure 15). The location of the rectangle was measured, documented and photographed for comparison studies after testing (see Figure 14). A total of thirty-two areas were documented.

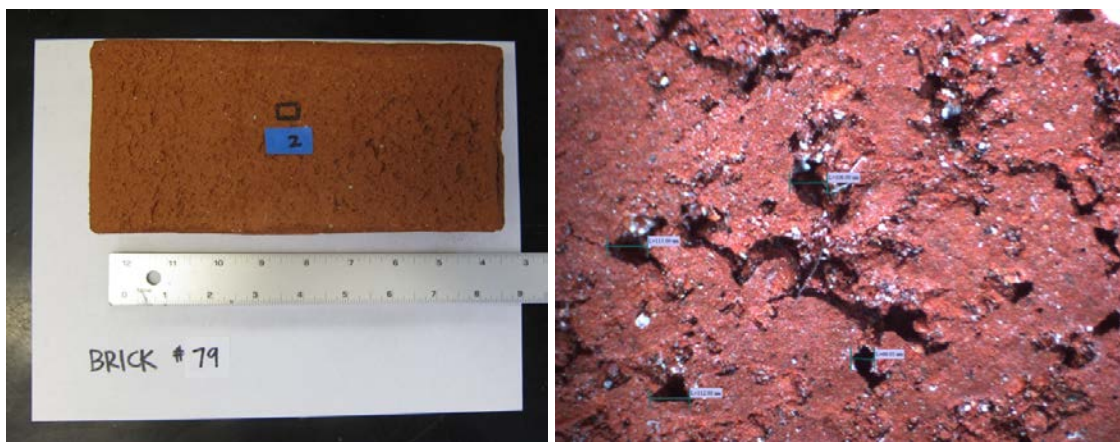

Figure 14 - Sample Documentation
Figure 15 - Sample Surface Pore Structure

5.1.2 Sample Preparation

Sample preparation was conducted indoors at the International Masonry Institute. Sample preparation was carried out according to “field-prepared” specifications from ASTM E518 and ASTM C1270 standards. Twenty-four prisms, consisting of six bricks each, were built.

Sample fabrication followed Glen-Gery recommendations to maximize results. Bricks were wet by masons prior to fabrication by being placed in plastic bins and submerged in tap water for three hours. Bricks were then laid on dry cloth until surface dry. Mortar was prepared by volumetric proportions to mimic field conditions. A bag of Glen-Gery Color Mortar Blend was mixed with three cubic feet of sand. Mortar blend was placed into a large plastic tub, followed by three cubic feet of sand using a shovel. The mix was stirred for three minutes manually until all components were evenly distributed. Water was added to the mix until it produced a workable consistency, which amounted to 2.5 gallons. The mix was then stirred for another three minutes. The mortar mixture was then shoveled into a smaller bin for transport.

Fabrication of all sample prisms was done by a single mason. Bricks were stacked in a single direction. The first brick of the prism was placed on a level table. Mortar was spread on top of the brick and a second brick was pushed on top using hand pressure until it was compressed to 3/8 inch. This method was repeated until six bricks were stacked on top of one another (see Figure 16). An additional brick was placed on top of the prism without mortar to add pressure to the top joint. All mortar joints were flush cut on both sides. Each prism was enclosed in a plastic bag immediately after fabrication for forty-eight hours. The plastic bags were then removed and samples cured indoors for an additional five days.



Figure 16 - IMI Mason Building Prisms



Figure 17 - 7-day Cured Sample Prisms Ready for Testing

5.1.3 Testing Procedures

All load test procedures were performed at Simpson, Gumpertz & Heger laboratory. Testing was carried out in accordance with ASTM E518 and ASTM C1270 standards under the supervision of SGH laboratory staff. Samples were transported to the SGH laboratory from the IMI in an automobile driven by author. To minimize disturbance and vibrations, samples were placed in the trunk with ample cushions to dampen vibrations from the drive. Visual inspection was conducted upon arrival to determine any obvious de-bonding or broken prisms.

Fifteen prisms (consisting of a total of fifteen joints) were tested using the four-point bending test. A single prism was placed horizontally on a simple supported, four-point bending apparatus. The upper steel pins were spaced 3 inches apart, aligning to the center of the center bricks. The lower pins were spaced 13 inches apart, aligning to the outermost bricks (see Figure 18). The load was then applied at a rate of 0.010 inches/minute to the top plate until failure. This test was repeated for fifteen prisms.

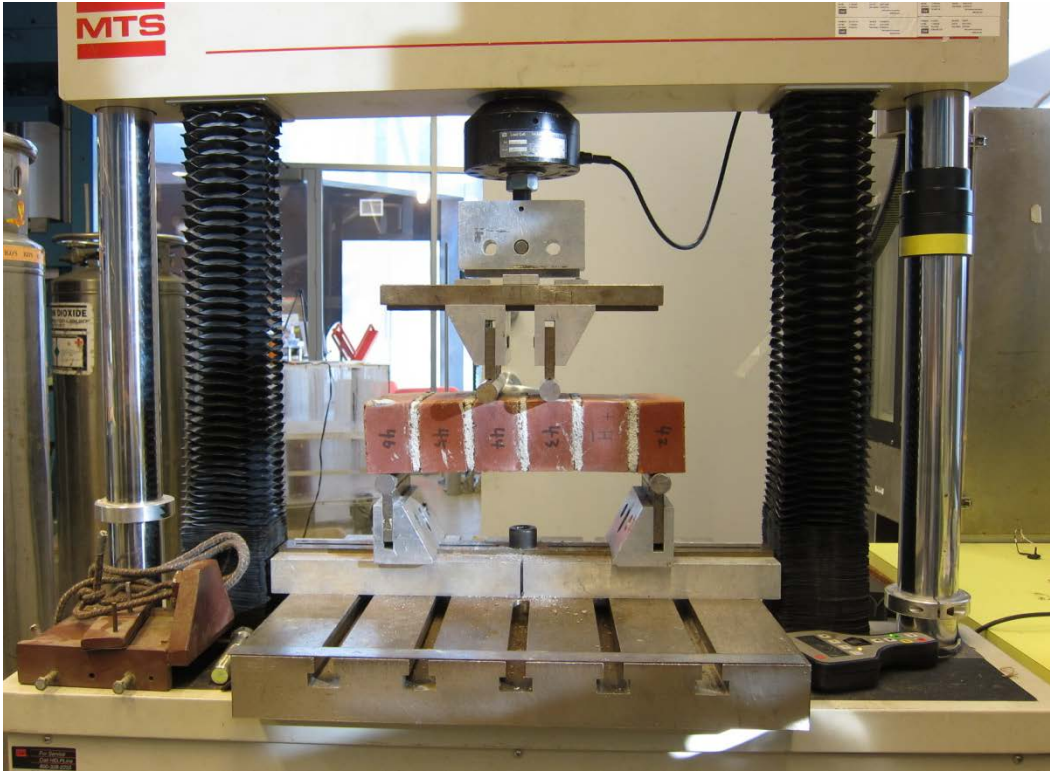

Figure 18 - Four-point Bending Test Setup

Nine prisms (consisting of a total of forty-five joints) were tested using the bond wrench apparatus. A single prism was placed in the bond wrench apparatus and the top brick was clamped to the upper bracket. The second brick was tightened to the lower clamp (see Figure 19). The load was then applied incrementally at a rate of 0.25 inches/minute. Following failure, the brackets were removed and the prism was raised to test the subsequent joint. The top brick was clamped to the upper bracket and the second brick was tightened to the lower clamp again. This was repeated for all nine prisms.

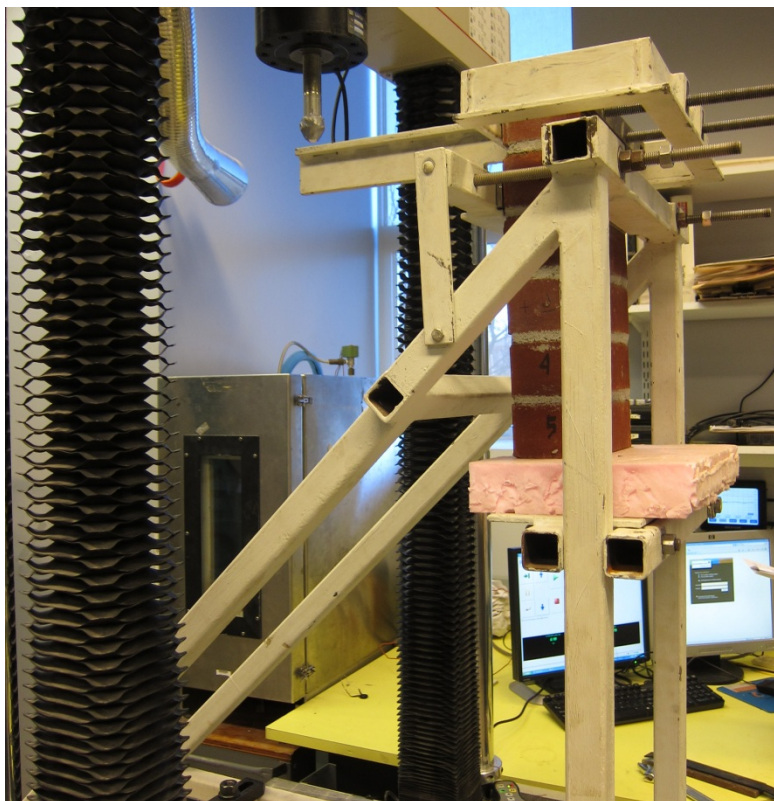

Figure 19 - Bond Wrench Test Setup

5.1.4 Cleaning Tests

Sample prisms were transported back to the IMI for cleaning. Cleaning methods were carried out by the author in accordance with brickwork cleaning techniques described in “The Brick Cleaning Manual” by *Think Brick Australia*¹³⁰. Three stages of cleaning were carried out.

Stage 1 included using a hammer and chisel to tap mortar off. Stage 2 included all cleaning techniques of Stage 1 followed by a thorough cleaning using a wire brush. Stage 3 included all cleaning techniques of Stage 1 and 2 followed by a single application of acid on the brick surface. One part muriatic acid was mixed with ten parts water. Bricks were

¹³⁰ “The Brick Cleaning Manual,” *Think Brick Australia* (2008), accessed February 1, 2013. http://www.thinkbrick.com.au/assets/documents/technical_information/brickwork/TBR4978Cleaning-Masonry2HR1.pdf

saturated in water for five minutes and then acid was applied using a paint brush. Bricks were then submerged in large plastic bins of water to neutralize them.

5.1.4 Final Testing

After cleaning, secondary documentation of brick pore surfaces by the author was conducted in Columbia University's conservation lab. Brick surfaces were photographed using a Bausch + Lomb Stereozoom 10x microscope. The thirty-two documented surfaces were placed under the microscope for secondary documentation of the pore structure. Before and after photographs are placed side by side for visual comparison.

Sample prisms were fabricated again at the IMI under the craftsmanship of the same mason, using the same techniques reported in Section 5.1.2. Bricks were laid in the same order and direction as initial sample preparation.

Samples were transported and tested in the same manner as reported in Section 5.2.2. Prisms were tested in the same order as initial testing. Sample prisms were transported back to the IMI for cleaning. Cleaning methods were carried out by the author as described in Section 5.1.4.

After secondary cleaning, final documentation of brick pore surfaces was conducted in Columbia University's conservation lab by the author following procedures of Section 5.1.1.

5.2 Water Absorption Results

Brick	Cleaning Method	% Absorption						IRA	
		1 min.	5 min.	10 min.	1 hr.	5 hr.	24 hr.		
1	New	0.7%	1.3%	1.9%	5.4%	5.9%	6.2%	10.9	
2		1.1%	1.9%	2.5%	5.0%	6.2%	6.8%	10.4	
3		1.4%	2.7%	3.6%	6.5%	6.8%	6.9%	15.1	
4		0.8%	1.5%	2.1%	5.9%	6.1%	6.9%	12.4	
5		1.2%	2.1%	2.5%	5.4%	5.7%	5.6%	11.0	
<i>AVG</i>		1.0%	1.9%	2.5%	5.6%	6.1%	6.5%	12.0	
<i>COV</i>		27%	29%	27%	10%	7%	9%	16%	
								After 1 st mortar application	After 2 nd mortar application
1	Stage 1	0.8%	1.5%	2.4%	5.1%	6.2%	6.2%	9.8	10.4
2		1.0%	2.1%	3.5%	5.5%	5.7%	5.9%	9.4	10.4
3		1.0%	1.0%	2.4%	5.3%	5.5%	5.8%	9.5	10.7
4		0.9%	1.8%	2.2%	5.1%	5.2%	5.9%	9.2	9.9
5		0.8%	1.7%	2.4%	4.6%	6.1%	6.4%	7.8	8.5
<i>AVG</i>		0.9%	1.6%	2.6%	5.1%	5.7%	6.0%	9.2	10.0
<i>COV</i>		11%	27%	20%	6%	8%	4%	9%	9%
1	Stage 2	0.8%	1.1%	2.0%	5.1%	5.3%	5.7%	8.2	8.6
2		0.8%	1.7%	2.6%	4.7%	5.0%	5.2%	8.2	7.6
3		0.7%	1.0%	2.4%	4.4%	4.5%	4.6%	6.3	7.5
4		1.0%	1.8%	2.4%	4.9%	4.9%	5.9%	8.5	9.2
5		0.8%	1.4%	3.4%	5.5%	5.8%	6.0%	7.9	8.2
<i>AVG</i>		0.8%	1.4%	2.6%	4.9%	5.1%	5.5%	7.8	8.2
<i>COV</i>		16%	26%	20%	9%	10%	10%	11%	9%
1	Stage 3	0.7%	1.1%	2.5%	4.5%	5.4%	5.9%	8.8	9.4
2		0.7%	1.2%	1.9%	4.2%	4.5%	4.7%	6.6	8.7
3		0.6%	1.3%	2.2%	4.1%	4.3%	4.5%	6.7	7.5
4		0.4%	1.4%	2.2%	3.9%	3.9%	4.5%	5.4	5.7
5		0.6%	1.1%	1.9%	4.0%	4.4%	4.7%	6.8	7.0
<i>AVG</i>		0.6%	1.2%	2.1%	4.1%	4.5%	4.9%	6.9	7.7
<i>COV</i>		17%	11%	12%	6%	12%	12%	17%	19%

5.3 Bond Wrench Results

Prism	Joint	New Brick		Cleaning Method	Reclaimed Brick (after 1 st Mortar Application)	
		Flexural Bond (psi)	Failure Mode		Flexural Bond (psi)	Failure Mode
1	1	62.3	Upper	Stage 1	80.8	Upper
	2	88.1	Upper		100.6	Both
	3	60.1	Upper		60.7	Upper
	4	Damaged	N/A		69.5	Upper
	5	62.7	Upper		62.2	Upper
	AVG	68.3			74.8	
	COV	19%			22.%	
2	1	57.6	Upper	Stage 1	57.5	Upper
	2	52.2	Upper		100.6	Upper
	3	52.0	Upper		71.3	Upper
	4	67.4	Lower		124.2	Upper
	5	Damaged	N/A		85.4	Upper
	AVG	57.3			87.8	
	COV	13%			30%	
3	1	60.3	Upper	Stage 1	70.3	Upper
	2	70.3	Upper		105.3	Upper
	3	56.4	Upper		70.9	Upper
	4	67.7	Lower		96.3	Upper
	5	44.2	Upper		74.2	Upper
	AVG	59.8			83.4	
	COV	17%			19%	
4	1	46.9	Upper	Stage 2	65.6	Upper
	2	98.7	Upper		108.9	Upper
	3	79.4	Upper		85.0	Lower
	4	56.3	Upper		104.4	Upper
	5	54.2	Upper		79.0	Upper
	AVG	67.1			88.6	
	COV	32%			20%	
5	1	49.5	Upper	Stage 2	75.2	Upper
	2	85.9	Upper		104.2	Upper
	3	59.1	Upper		107.7	Upper
	4	79.4	Upper		94.5	Upper
	5	26.9	Upper		40.2	Upper
	AVG	60.1			84.4	
	COV	39%			33%	

Prism	Joint	New Brick		Reclaimed Brick (after 1 st Mortar Application)		
		Flexural Bond (psi)	Failure Mode	Cleaning Method	Flexural Bond (psi)	Failure Mode
6	1	53.9	Upper	Stage 2	76.4	Upper
	2	87.6	Upper		96.6	Upper
	3	68.5	Upper		115.1	Upper
	4	57.0	Upper		104.1	Upper
	5	36.2	Upper		59.7	Upper
	<i>AVG</i>	<i>60.7</i>			<i>90.4</i>	
<i>COV</i>	<i>31%</i>		<i>25%</i>			
7	1	54.4	Upper	Stage 3	103.8	Upper
	2	55.7	Upper		98.0	Upper
	3	85.2	Upper		106.6	Upper
	4	97.6	Lower		136.9	Lower
	5	59.4	Upper		104.3	Upper
	<i>AVG</i>	<i>70.4</i>			<i>109.9</i>	
<i>COV</i>	<i>28%</i>		<i>14%</i>			
8	1	Damaged	N/A	Stage 3	107.7	Upper
	2	58.0	Lower		111.7	Upper
	3	77.8	Upper		113.5	Upper
	4	47.2	Upper		61.2	Upper
	5	39.5	Upper		75.57	Upper
	<i>AVG</i>	<i>55.6</i>			<i>93.9</i>	
<i>COV</i>	<i>30%</i>		<i>26%</i>			
9	1	57.2	Upper	Stage 3	95.4	Upper
	2	61.4	Lower		115.1	Upper
	3	79.2	Upper		120.9	Upper
	4	53.8	Upper		74.5	Upper
	5	47.7	Upper		89.9	Upper
	<i>AVG</i>	<i>59.9</i>			<i>99.3</i>	
<i>COV</i>	<i>20%</i>		<i>19%</i>			

5.4 Four-point Bend Results

Prism		New Brick		Reclaimed Brick (after 1 st Mortar Application)		
		Flexural Bond (psi)	Failure Mode	Cleaning Method	Flexural Bond (psi)	Failure Mode
10		49.21	B	Stage 1	64.22	B
11		68.14	E		73.69	B
12		35.37	C		82.68	A
13		34.48	B		54.11	B
14		40.41	D		67.09	A
	<i>AVG</i>	45.52			68.36	
	<i>COV</i>	30.60%			15.61%	
15		67.77	E	Stage 2	108.70	C
16		41.28	B		81.41	B
17		48.58	B		87.96	A
18		47.92	B		97.28	B
19		41.75	B		112.49	B
	<i>AVG</i>	49.46			97.57	
	<i>COV</i>	21.80%			13.56%	
20		46.21	B	Stage 3	117.93	B
21		41.18	B		66.37	B
22		53.15	E		117.52	B
23		31.06	B		98.91	A
24		52.74	E		Damaged	N/A
	<i>AVG</i>	44.87			100.2	
	<i>COV</i>	20.45%			24.18	

Chapter 6: Analysis

6.1 Brick Properties

6.1.1 Water Absorption

As described in Chapter 2, water absorption by brick greatly affects bond strength. Water absorption is an indication of porosity.¹³¹ While the total amount of water absorbed is not a great factor, the rate at which the water is absorbed is important.¹³² The initial rate of absorption of bricks was tested because it has been determined that suction is an important characteristic of bond strength.¹³³ As discussed by W. Mark McGinley, the initial rate of absorption correlated to flexural bond strength in his experimental study.¹³⁴ For this thesis, IRA values of new brick and reclaimed bricks were studied to determine if corresponding flexural strengths also followed trends indicated in McGinley's research.

Table 6 shows that the IRA of new brick was the highest, followed by lower IRA values for each succeeding stage of cleaning. This suggests that there may be some correlation between the brick IRA and the method of cleaning.

Table 5 - Initial Rate of Absorption of Bricks

	New Brick	Reclaimed Brick after 1 st Mortar Application		
		Stage 1	Stage 2	Stage 3
IRA g/min/30in ²	12.0	9.2	7.8	6.9

Based on mean value of 5 tests

¹³¹ Clayford T. Grimm, "Durability of Brick Masonry: A Review of the Literature." In *Masonry: Research, Application and Problems*, ASTM STP 871, ed. J.C. Grogan and J.T. Conway (Philadelphia: American Society for Testing and Materials, 1985): 207.

¹³² Bailey, Matthys and Edwards, "Initial Rate of Absorption," 6.

¹³³ McGinley, "IRA and the Flexural Bond Strength," 228.

¹³⁴ *Ibid*, 217-218.

Figure 20 shows a comparison of the weight of water absorbed by submerging bricks over time. New bricks had the highest absorption rate, followed by Stage 1 bricks, Stage 2 bricks and Stage 3 bricks. This is consistent with IRA values and suggests that there is a correlation between increasing cleaning measures and cold water absorption characteristics of brick.

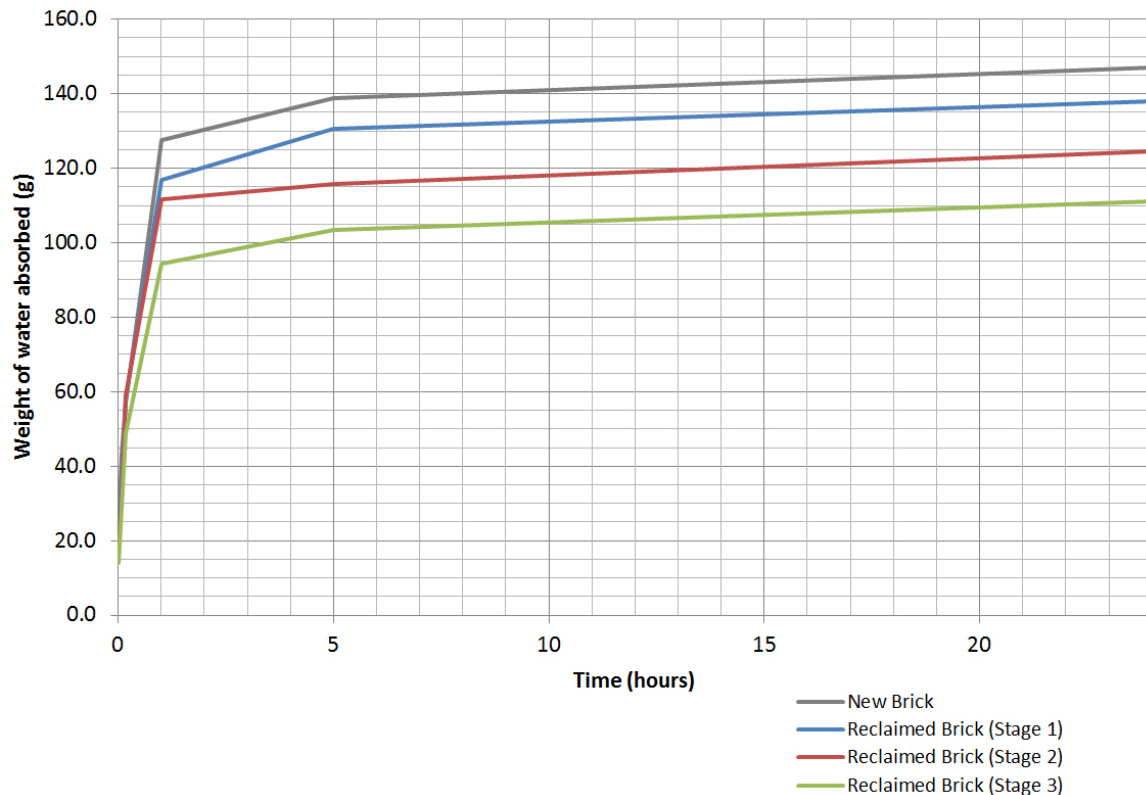

Figure 20 - Graph of Brick Water Absorption

It is possible that the moisture content of the bricks was higher during the construction of the second sample set, which lead to lower IRA and absorption values for reclaimed bricks. After the first samples were tested, all bricks were cleaned in accordance with the selected cleaning methods. Because Stage 2 and Stage 3 cleaning techniques involved submerging bricks in water multiple times, bricks absorbed increasing amounts of water. Stage 2 bricks were submerged in water for less than one minute, while Stage 3 bricks

were submerged in water for five minutes, followed by an application of acid, followed by submerging bricks in water for another minute. Bricks were stored indoors at the International Masonry Institute for 2 days. The bricks were then transported to the Columbia University laboratory for absorption tests. Specimens were dried in ambient temperatures instead of oven dried, as indicated in ASTM C67. Thus, specimens could have some moisture left within the brick at the time of new absorption tests.

6.1.2 Surface Pores



Photographs of surface pores after different cleaning techniques are in the Appendix. Visual inspection of each surface showed varying levels of mortar residue on the surface of bricks. New bricks had no mortar residue and open pores. Stage 1 cleaned bricks had varying degrees of mortar residue on the surface. Mortar was restricted to surface level of brick and large pores did not appear to be filled. Stage 2 cleaned bricks also had varying degrees of mortar residue on the surface. Some smaller pores appeared to be filled, while large pores did not appear to be filled with mortar, but were very similar to Stage 1. Stage 3 cleaned bricks had very little mortar residue on the surface level of brick. Many small pores appeared to be filled with mortar, while larger pores remained clean.

After initial cleaning, bricks did not exhibit a great deal of “clogged pores” as had been expected based on the EES study. Residue left on Stage 1 and Stage 2 bricks was visually similar. There were some instances of smaller pores filled with mortar deposits exhibited in Stage 2 bricks. This could be from the scraping action of the brush, moving from side to side on the surface and into the pores. However, there did not appear to be much of a difference between these two cleaning stages. Brush cleaning did not appear to facilitate cleaning of mortar residue from the surface of bricks. Residue left on Stage 3

bricks was distinctly different from Stage 1 and 2. Pieces of mortar wedged into smaller pores were apparent. The acid wash was very effective in clearing residue left on the surface, but not within the pores.

After secondary cleaning, bricks exhibited more “clogged pores”. Mortar residue left on Stage 1 and Stage 2 bricks was very similar. There was apparent mortar residue on the surface of the bricks and larger pores were also filled with some mortar. Again, brush cleaning did not appear to facilitate cleaning of mortar residue from the surface of the bricks. Stage 3 bricks were again noticeably different from Stage 1 and Stage 2. Stage 3 bricks showed little mortar residue on the surface, but many small and large pores were filled with residue.

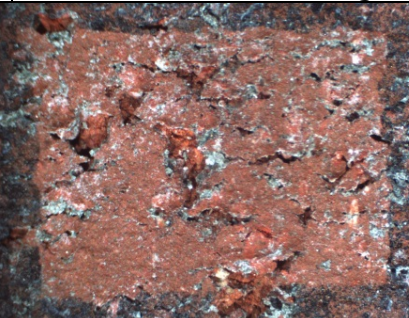
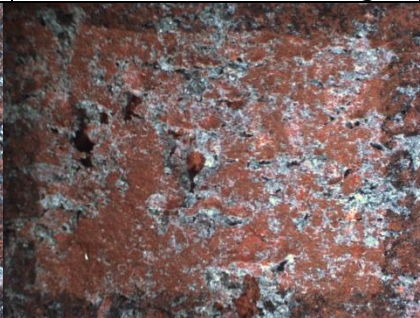
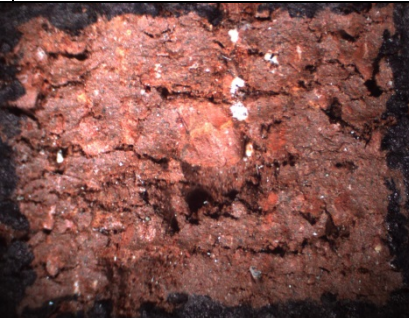
Table 6 - Photographs of Brick Pores Before and After Cleaning

	New Brick	After 1 st mortar cleaning	After 2 nd mortar cleaning
Stage 1			
		Mortar residue on surface Large pores unfilled	Mortar residue on surface Large pores partially filled
Stage 2			
		Mortar residue on surface Large pores unfilled	Mortar residue on surface Large pores partially filled

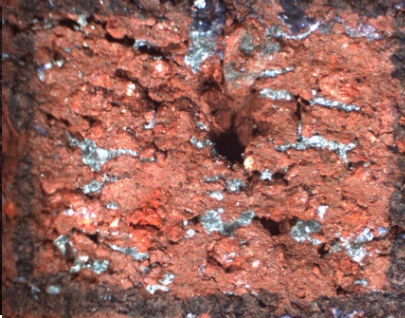
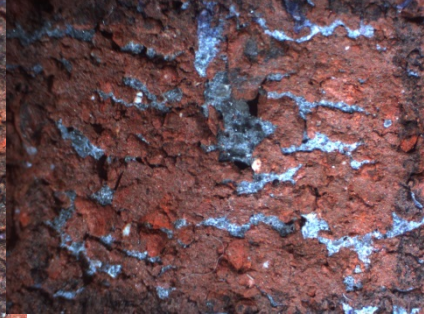
Stage 3			
		Little mortar residue on surface Many small pores filled Large pores unfilled	Little mortar residue on surface Many small pores filled Large pores partially filled

6.1.3 Water Absorption v. Pore Surface

Visual analysis of surface structure indicated that the more intensive cleaning measures exposed larger amounts of residue within the pores of bricks. This conclusion affirms the results of IRA tests which indicated that the more intensive cleaning measures lead to lower IRA. The reason for this could be that dry mortar was less absorptive than the brick. To test whether this might be the case, the author conducted IRA tests on dry pieces of mortar from the first and second building using the same technique as the bricks. The results indicated that the initial rate of absorption is less than new bricks and reclaimed bricks.

Table 7 - Initial Rate of Absorption of Mortar

	Mortar 1	Mortar 2
IRA (g/min/30in ²)	6.45	5.19

Based on mean value of 5 tests

As seen in Figure 21, the average IRA decreased as the amount of cleaning increased after both the 1st and 2nd mortar applications. New bricks exhibited the highest IRA, while bricks that had undergone Stage 3 cleaning displayed the lowest IRA. After the 2nd mortar

application, bricks exhibited the increased IRA compared to the 1st mortar application, but they followed the patter of decreasing IRA. Bricks that had undergone Stage 1 cleaning had the highest IRA and bricks that had undergone Stage 3 cleaning exhibited the lowest IRA.

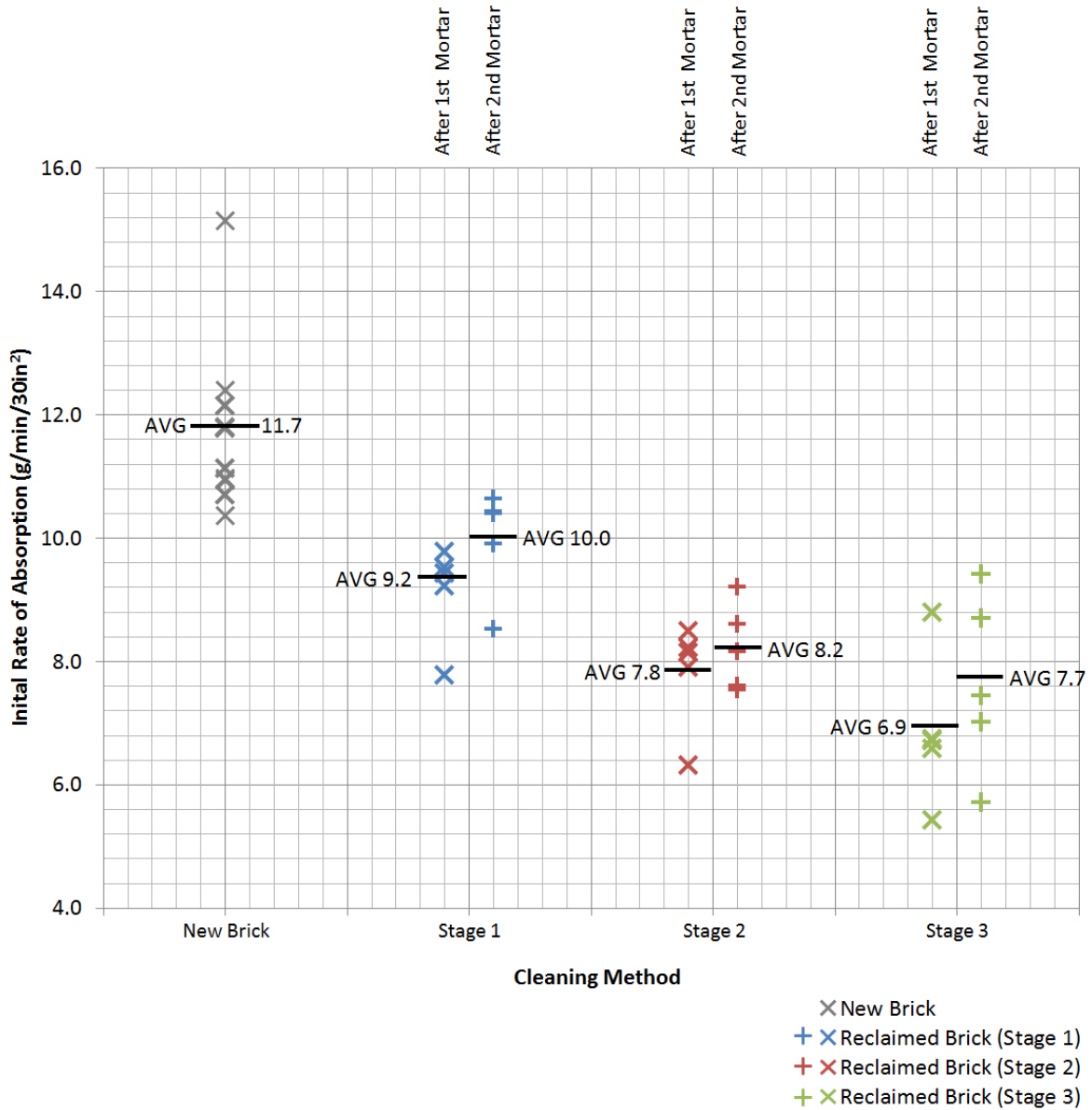

Figure 21 - Graph of IRA vs. Cleaning Method

As seen in Table 9, after the 2nd mortar application, Stage 1, 2 and 3 bricks had a slightly higher IRA.

Table 8 - Initial Rate of Absorption of Brick After 1st and 2nd Mortar Application

	New Brick	Reclaimed Brick		
IRA (g/min/30in²)		Stage 1	Stage 2	Stage 3
After 1 st Mortar Application	11.7	9.2	7.8	6.9
After 2 nd Mortar Application		10.0	8.2	7.7
Percent Change	-	9%	5%	12%

Visual inspection of pore surfaces indicated that more mortar residue was left on bricks after the 2nd application of mortar. IRA results indicated that bricks have higher absorption qualities after the 2nd application of mortar. This pattern is inconsistent with the previous conclusion that dry mortar blocks pores and leads to lower IRA. Therefore, it does not appear that the initial rate of absorption is correlated to the amount of mortar residue left on the surface of bricks.

6.2 Bond Properties

The forces of adhesion and cohesion make up bond strength. Forces attracting mortar to itself is called cohesion and forces attracting mortar to the brick surface is adhesion. Cohesion is measured by the consistency of failure methods during testing. Adhesion is measured by the consistency of flexural tests during testing.

6.2.1 Cohesion

There are four different possible failure methods, three of which were exhibited during the bond wrench test. Initial testing of prisms resulted in failure at upper brick-

mortar interface 83% of the time. Final testing resulted in failure at the same upper brick-mortar interface 93% of the time. This indicates that the cohesion properties within the mortar were very consistent in both sample prism batches. 0% of all joints failed within the mortar. This suggests that the flexural bond within the mortar is much higher than the flexural bond between the brick-to-mortar interface. While cohesion is an important aspect of bond strength, adhesion of mortar to brick is evidently more important because it is at this interface where brick-to-mortar assemblies fail most often.

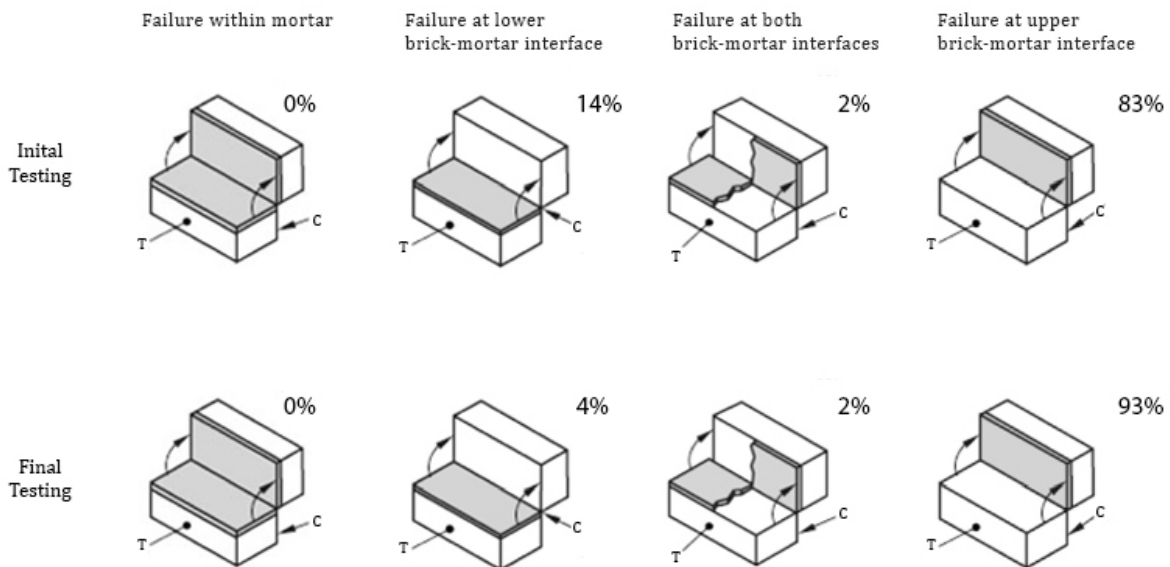

Figure 22 - Percentage of Bond Wrench Test Prisms Displaying Each Failure Mode¹³⁵

Five different failure methods were exhibited during the four-point bend test. Initial testing of prisms resulted in failure at the upper brick to mortar interface between center bricks 60% of the time. Final testing resulted in failure at the same upper brick to mortar interface between center bricks 57% of the time. This indicates that the cohesion properties within the mortar were consistent in both sample prism batches as indicated by the four-

¹³⁵ S. Pavia and R. Hanley, "Flexural Bond Strength of Natural Hydraulic Lime Mortar and Clay Brick," *Materials and Structures* 43 (2010): 94.

point bend test. Again, 0% of all joints failed within the mortar, signifying that the flexural bond within the mortar is much higher than the flexural bond between the brick-to-mortar interface.

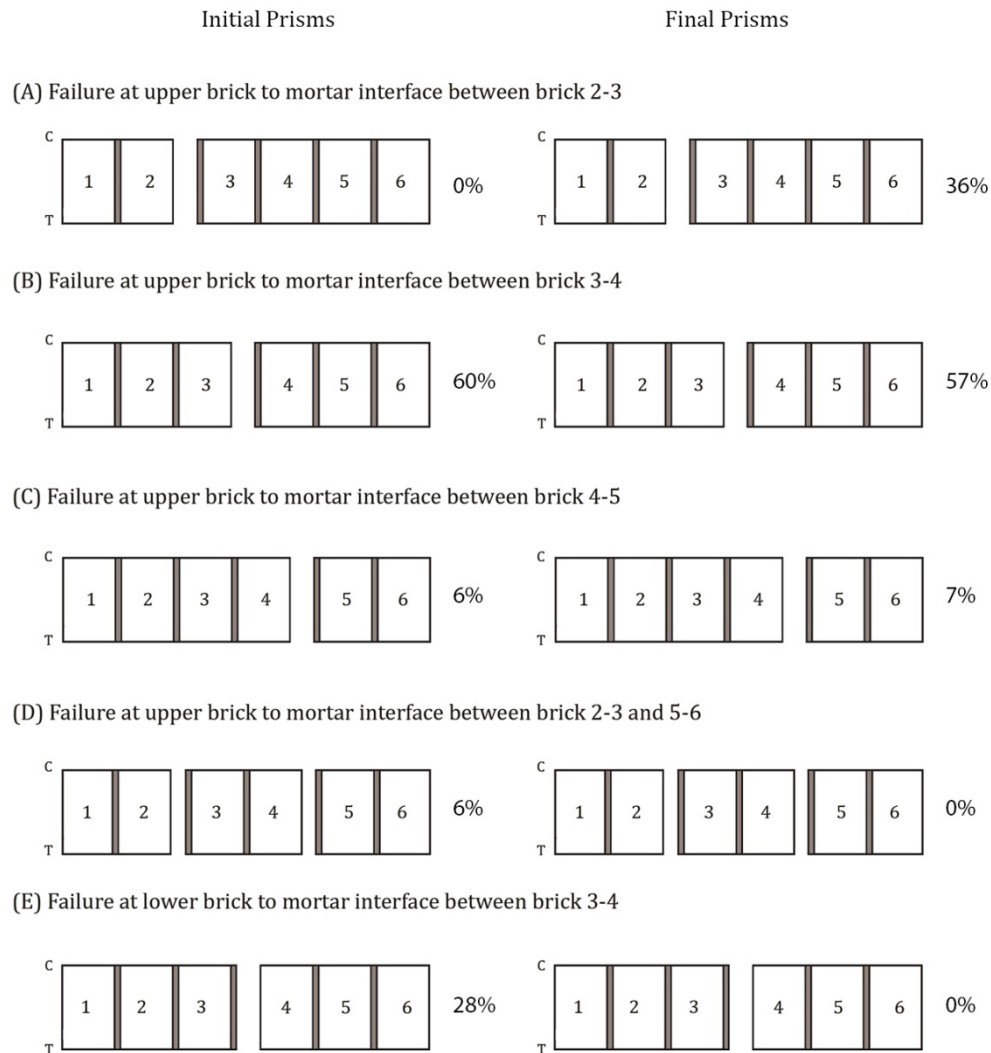

Figure 23 - Percentage of 4-point Bend Test Prisms Displaying Each Failure Mode

6.2.2 Adhesion

The forces of adhesion are measured in accordance with ASTM C1072 bond wrench test and ASTM E518 four point bend test. Flexural bond strength results for each sample prism are given in Table 10. Individual results for all prisms are provided in the Appendix.

Table 9 - Average flexural strength of specimens

Test	New Brick		Reclaimed brick after 1 st Mortar Application					
	Flexural strength (psi)	COV	Stage 1		Stage 2		Stage 3	
			Flexural strength (psi)	COV	Flexural strength (psi)	COV	Flexural strength (psi)	COV
Bond Wrench	62.4 ^[1]	26%	82.0 ^[2]	24%	87.8 ^[2]	24%	98.4 ^[3]	18%
Four-point Bend	46.6 ^[2]	23%	68.4 ^[4]	16%	97.6 ^[4]	14%	100.2 ^[5]	24%

^[1]Based on mean value of 42 tests

^[4]Based on mean value of 5 tests

^[2]Based on mean value of 15 tests

^[5]Based on mean value of 4 tests

^[3]Based on mean value of 14 tests

Flexural bond strength results were somewhat different than expected. The bond strength of the reclaimed bricks was higher than that of the new bricks. These results suggest that the strength of bond increased after initial mortar application and cleaning. Flexural strength tests of reclaimed bricks after first mortar application all resulted in higher flexural strengths than clean new brick. Secondly, each stage of cleaning resulted in higher flexural strength. Thus, Stage 1 cleaning furnished the lowest flexural strength, followed by Stage 2 and Stage 3. The results were unexpected because as the literature indicated, flexural bond strength should decrease because pores are clogged when mortar is reapplied to brick.

Precise guidelines are not available for flexural bond testing. Published data under similar bond wrench testing conditions carry coefficients of variation between 10 and 25%.¹³⁶ In the tests conducted by the author, flexural bond strengths results from the bond wrench test range from 18 to 26%. This indicates that the coefficient of variance is within the acceptable range. On the other hand, there is little data published using the four-point bend test. Nonetheless, the coefficient of variation for this test ranges fall within the same range of 16 to 24%.

¹³⁶ American Society for Testing and Materials, "ASTM C1357-09: Standard Test Methods for Evaluating Masonry Bond Strength," doi:10.1520/C1357-09, 3.

The coefficient of variance for the bond wrench testing was influenced by a reduced number of tests. Three joints were not analyzed in the initial bond wrench testing because they broke prematurely in the testing apparatus. This most likely occurred during transport of the prisms to the laboratory. Upon inspection after transport, only one prism had broken, but after loading each individual prism into the bond wrench apparatus, two other joints failed prematurely. During the second bond wrench test, one joint broke prematurely and was not included in the analysis. The coefficient of variance for Stage 3 brick may be skewed high because only five samples were tested for each four-point bend test. Of the five specimens tested, the results of only four specimens were analyzed. One of the tests was not analyzed because it broke prematurely in the testing apparatus. Specific joints that were not analyzed are indicated in the Appendix.

Another explanation for the high coefficient of variance is due to the method in which the prisms failed. As Table 11 shows, the different failure methods indicate a range of flexural bond strengths.

Table 10 - Average flexural strength of specimens by failure method

Test	New Brick		Reclaimed brick after 1 st Mortar Application					
	Flexural strength (psi)	COV	Stage 1		Stage 2		Stage 3	
			Flexural strength (psi)	COV	Flexural strength (psi)	COV	Flexural strength (psi)	COV
Bond Wrench Test								
Upper	61.0	26%	80.6	24%	88.0	25%	98.4	18%
Lower	72.3	22%			85.0			
Both	98.7	-	100.6					
Within								
Four-point Bend Test								
A			74.9	15%	88.0	-	99.0	-
B	42.4	15%	64.0	15%	97.1	16%	100.6	29%
C	35.4	-			108.7	-		
D	40.4	-						
E	60.5	14%						

This chart indicates that the manner in which the prisms failed correlates to the flexural bond strength recorded. For the bond wrench test, joints that failed on the upper surface exhibited the lowest flexural strength, while joints that failed on both surfaces exhibited much higher flexural strength. The coefficient of variance was lower for the four-point bend test with the exception of the new brick. Table 11 also shows that the prisms that failed under conditions “E” revealed much higher flexural strengths than the rest of the failure modes. This could account for the higher coefficient of variance for new brick.

6.3 Flexural Bond Strength

6.3.1 Flexural Bond Strength v. Surface Pores

As demonstrated by these tests, the average flexural bond strength increased when mortar was reapplied to reclaimed bricks. This contradicts the perception that bond strength diminishes because the pores are clogged with mortar. Results show that the Stage 3 cleaned bricks exhibit the highest bond strength even though they displayed the most mortar residue deep in the pores.

Figure 24 shows the relationship between flexural bond strength and cleaning methods. The more intensive cleaning methods resulted in higher average flexural bond strength. This indicates that there is some correlation between higher flexural bond strength and mortar residue left in brick pores.

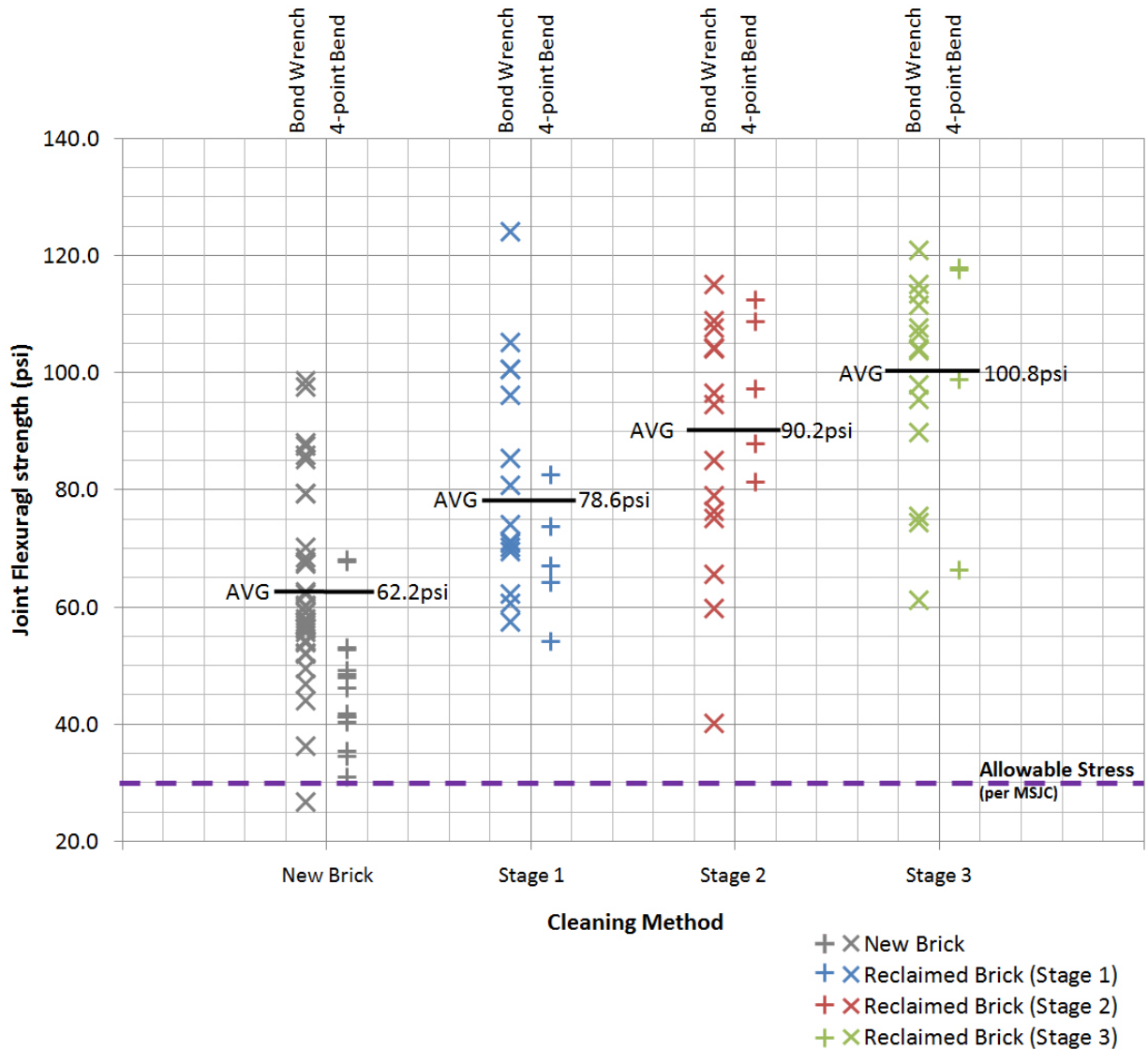

Figure 24 – Flexural Strength vs. Cleaning Method

6.3.2 Flexural Bond Strength v. Water Absorption

IRA is an indicator of flexural bond strength as concluded by multiple reports summarized in the Literature Review of this thesis. IRA is not a qualifying condition of bricks for specification, but is used to assist in mortar selection and material handling in the construction process.¹³⁷ The Brick Industry Association recommends brick with an IRA between 10 to 30 g/min/30in² for use

¹³⁷ American Society for Testing and Materials, “ASTM C216-12a: Standard Specification for Facing Brick (Solid Masonry Units Made from Clay or Shale).” doi:10.1520/C0216-12A, 4.

with Type N mortar. A study conducted by W. Mark McGinley indicates that the “optimum IRA” range is approximately 5 to 10 g/min/30in² for type N mortar.¹³⁸

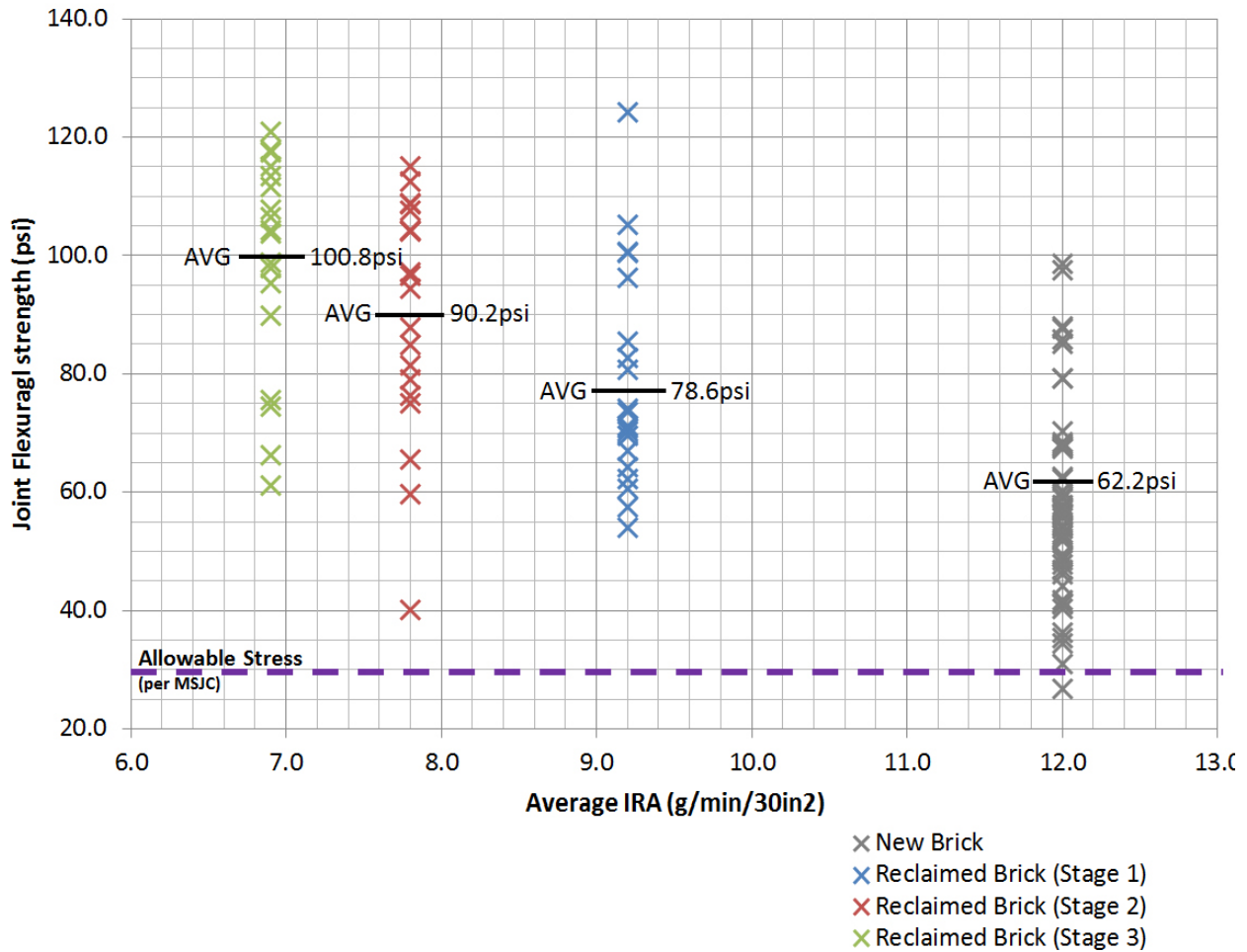

Figure 25 - Flexural Strength vs. Average IRA

It appears that flexural bond was reduced at higher brick IRA values. This is inconsistent with Lawrence and Cao’s report, “An Experimental Study of the Interface between Brick and Mortar” which researched the mechanism of bond at the microscopic level. Lawrence and Cao

¹³⁸ McGinley, “IRA and the Flexural Bond Strength,” 227.

suggest that a higher IRA will allow mortar to permeate the brick leading to higher bond strength.¹³⁹ However, they also stated that if the IRA is too high, the bond strength will be reduced because the mortar will shrink when curing, causing micro-cracking at the brick-to-mortar interface.¹⁴⁰ W. Mark McGinley's "optimum IRA" range is approximately 5 to 10 g/min/30in² for type N mortar.¹⁴¹ This could explain why the flexural bond strength of new brick is the lowest. The IRA of new brick was 12.0 g/min/30in², outside of the "optimum IRA" range when using type N mortar. However, the "optimum IRA" does not account for the changes in bond strength for reclaimed bricks. Stage 1 reclaimed bricks had the highest IRA of all cleaned bricks, but the lowest flexural bond strength.

6.4 Other Parameters Affecting Flexural Bond Strength

6.4.1 Moisture Content

Although the long-term water absorption of bricks is not a significant indicator of flexural bond strength, it served as a useful indicator when preparing brick assemblies. According to the Rao, Reddy and Jagadish study, the optimum moisture content for bricks at the time of laying is 77% of the total weight of water absorbed in 24 hours.¹⁴² However during this thesis testing, bricks were only submerged in water for approximately 3 minutes, resulting in a moisture content of approximately 20%.

6.4.2 Age

Curing conditions are a significant factor in bond strength. The development of flexural strength is due to the hydration of the Portland cement. Therefore, it is likely that the factors that influence the rate of cement hydration also directly influence the development of flexural strength in

¹³⁹ Lawrence and Cao, "An Experimental Study," 14.

¹⁴⁰ Ibid.

¹⁴¹ McGinley, "IRA and the Flexural Bond Strength," 227.

¹⁴² K. Venu Madhava Rao, B.V. Venkatarama Reddy and K.S. Jagadish, "Flexural Bond Strength of Masonry Using Various Blocks and Mortars," 123.

masonry.¹⁴³ It could be expected that continued hydration over longer periods of time would further increase the bond strength.¹⁴⁴ However, according to De Vitis Page and Lawrence's study, brick assemblages using Portland cement-lime mortar gained 70-100% of its 7-day strength after only 3 days.¹⁴⁵ After 7 days, there was an overall strength gain of 30-40%, although an "up and down" in strength variations were observed.

The 7-day curing cycle was chosen due to time constraints of this experiment. As indicated in the Sugo, Page and Lawrence study, prisms reached their maximum bond strength at 180 days.¹⁴⁶ Thus, the 7-day curing age could have contributed to the variety of test results as the prisms were still gaining strength.

6.4.3 Temperature

Although attempts were made to eliminate inconsistencies in curing conditions, some variable effects were observed. The temperature at which the samples were cured changed considerably for the initial prism samples and the final prism samples. The average curing temperature of the initial prisms was 55 degrees Fahrenheit and 66 degrees for the final prisms. ASTM C1072 and E518 mandate that prisms cure in laboratory temperatures of $75^{\circ} \pm 15^{\circ}\text{F}$. Prisms were cured indoors, but not in laboratory conditions. Temperatures were not monitored inside the room in which the prisms were curing. Therefore, outdoor daily temperatures were used to indicate temperature fluctuations during the aging process. General temperature readings were collected from AccuWeather using the zip code of the location in which the prisms were placed.¹⁴⁷

¹⁴³ Sugo, Page and Lawrence, "Influence of Age," 1433.

¹⁴⁴ Ibid.

¹⁴⁵ De Vitas, Page and Lawrence, "Influence of Age," 64-68.

¹⁴⁶ Sugo, Page and Lawrence, "Influence of Age," 1441.

¹⁴⁷ Weather temperatures were obtained from AccuWeather (accuweather.com). First prism sample data points are taken from the actual high and low outdoor temperatures observed on March 27-April 2, 2013 in 11101 (Long Island City, NY) and April 3, 2013 in 02453 (Waltham, MA). Second prism sample data points are taken from the actual high and low

Although temperature readings reflect outdoor conditions, the change in temperature was noticeable in the indoor environment. The temperature at which Prism Sample 2 cured was slightly higher on average than the temperature at which Prism Sample 1 cured. However, Prism Sample 2 cured at much higher temperatures during the first 48 hours. Figure 27 indicates temperature highs and lows of the outdoor temperature for each day of curing for both prisms.

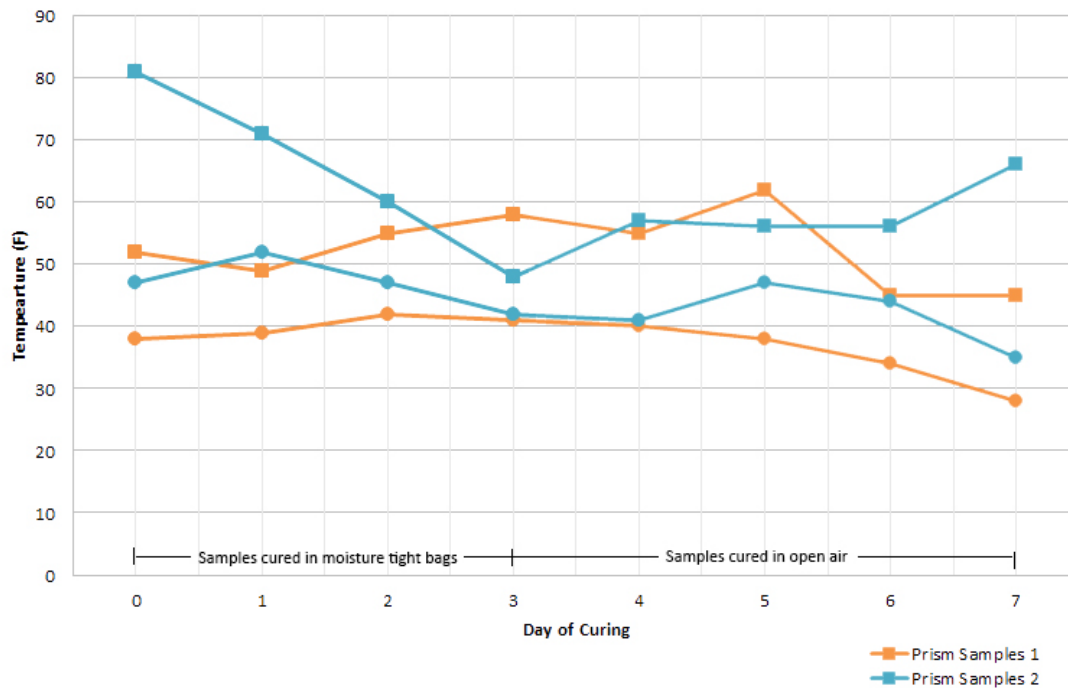

Figure 26 - High and Low Temperature for During Curing of Sample Prisms

According to ASTM C270, weather conditions should be considered when selecting mortar. Warmer weather leads to loss of water in the mortar by evaporation.¹⁴⁸ Warmer temperatures also affect masonry units. In lower temperatures, brick suction is reduced.¹⁴⁹ Hydration of the Portland cement in the mortar is activated by water. Mortar cures as water is absorbed by the brick and

outdoor temperatures observed on April 10-16, 2013 in 1101 (Long Island City, NY) and April 17, 2013 in 02453 (Waltham, MA).

¹⁴⁸ American Society for Testing and Materials, "ASTM C270-12," 11.

¹⁴⁹ J.I. Davison, "Effect of Temperature on Brick Suction," *Journal of Testing and Evaluation* 10, no.3 (1982): 81.

evaporates. The reaction rate is temperature dependent.¹⁵⁰ Therefore, the higher instances of flexural bond strength in the second prisms could partially be attributed to the warmer temperatures. Mortar could have cured much more quickly due to the rapid hydration of the Portland cement in the warmer temperatures, particularly the high temperatures in the first 72 hours.

6.5 Building Code Requirements

As indicated in Chapter 2, the allowable flexural tensile stress for clay and concrete masonry is 30psi for Type N mortar. In this experiment, new bricks and all reclaimed bricks demonstrated flexural bond strengths above the allowable 30psi. In Prism 5, the fifth joint resulted in flexural bond strength of 26.9psi using the bond wrench test. Upon further examination of this joint, it is unclear why this particular joint resulted in an unusually low flexural stress. It is possible the joint may have been damaged during transport without notice during inspection.

¹⁵⁰ “Masonry Mortars.”

Chapter 7: Conclusion

The purpose of this thesis was to determine if the brick to mortar bond strength changes when reusing brick and continuously applying new mortar. Most published studies cover the topic of brick to mortar bond strength in new bricks, yet very little has been written about the reuse of bricks. The Engineering Experiment Station at the University of New Hampshire conducted a study on the “Relative Adhesion of Mortars to New and Used Brick” in 1934, but it was determined by the author that the experiment’s use of “used” bricks is more clearly defined as salvaged bricks.

7.1 Limitations

There were many limitations to this experimental study. First, the failure of the first set of prisms created a major time constraint. Prisms were originally set to cure for 28-days, as indicated in ASTM C1072. However, because the first set of prisms did not properly bond, samples were only cured for 7-days. As mentioned in Chapter 6, the 7-day curing increased the margin of variability.

Transporting sample prisms to the SGH laboratory in Waltham, MA from Queens, NY proved to be a difficult task. Prisms shifted during the car ride and three prisms were broken due to the vibrations. Samples could have also been adversely affected by movement; affects that were not detected by visual examination.

Only five samples were tested for each cleaning method using the four-point bend flexural test. Although ASTM E518 specifies a minimum of five samples to be tested, a larger sample size could help produce more consistent results.

7.2 Test Results

From the figures and information included in this study, the author finds the following conclusions.

1. IRA v. Cleaning

There appears to be some correlation between the cleaning method and initial rate of absorption. New bricks had the highest IRA, followed by reclaimed bricks cleaned via Stage 1, Stage 2 and Stage 3 procedures. The amount of mortar residue left on brick surface does not seem to be an indicator of IRA.

2. Flexural Bond Strength v. Cleaning

The flexural bond strength of brick to mortar increases as brick is cleaned more forcefully. Washing bricks with acid proved to be the most effective in increasing bond strength. However, it is not recommended that this cleaning method be used on a job site unless it is carried out properly and with caution. Muriatic acid is highly reactive and corrosive. It is also clear and colorless, which makes it easily mistaken for other liquids.

3. Flexural Bond Strength v. IRA

There appears to be a relationship between flexural bond strength and the initial rate of absorption of bricks with mortar residue. As shown in Figure 26, flexural bond strength decreases as the average IRA of bricks increases. Therefore, it is recommended that bricks that are going to be reused be tested for IRA properties before use.

4. New Brick v. Reclaimed Brick

Based on the results obtained, within the scope of this experiment, the flexural bond strength of reclaimed brick is higher than that of new brick. Flexural bond strengths increased after mortar was applied for the second time.

Results from this experiment contradict test results from the Engineering Experiment Station study which indicate a significant loss of bond strength for used brick. However this thesis experiment and the EES experiment differ in three important aspects. The first is that the EES study tested the bond strength of molded bricks, while this thesis tested extruded bricks which have

a much more open pore structure. Secondly, the EES study does not describe the testing mechanism used to measure bond strength. It only indicates that the prisms were “broken apart by tension in a testing machine.”¹⁵¹ It is unclear if the study conducted direct tensile testing or flexural testing. And lastly, the used bricks tested in the EES study are, as defined in this thesis, salvaged brick as opposed to reclaimed brick.

7.3 Future Study

While this project was able to investigate important aspects of the mechanical properties of brick to mortar adhesion, it is by no means a conclusive study of the topic. There are many areas of future study that could add to the body of knowledge.

It is recommended that this experiment be replicated using molded bricks as originally intended. The adhesive bond qualities of mortars may prove to be complicated for molded brick bed surfaces. These results could offer more comparable results to the EES study. Brick pores were also not as “clogged” as expected. This may be due to the limited curing time. It is recommended that studies be conducted of prisms cured for 28-days and longer to understand long-term brick to mortar interactions.

Because of the limited amount of time, many variables were not tested. Surface pore structure is only one variable out of the many other variables that affect brick to mortar bond strength. It is recommended that all of the variables considered in Chapter 3 be tested in future experiments.

¹⁵¹ Engineering Experimental Station, “Relative Adhesion,” 6.

Appendix

A.1 First set of brick

The first set of bricks chosen for this experiment was the Glen-Gery 53DD standard molded brick. A molded brick was chosen because it most resembled characteristics of historic brick manufacturing. The molded bricks maintain two distinct bed surface textures –one side that was placed in the mold and the outer side. Bricks with significant cracks or chips were not used to build test prisms. Glen-Gery 53DD bricks are manufactured to conform to the requirements of ASTM C216 Standard Specification for Facing Brick, Grade SW (Severe Weathering), Type FBS (Face Brick Standard) and all grades of “ASTM C62: Standard Specification for Building Brick”^{152, 153}.

Table 11 - Glen-Gery Brick Size, Coverage and Weight¹⁵⁴





Brick Size	Specified Dimension						Brick per square foot	Average Weight per unit (kg)	
	Thickness (inches) (mm)		Height (inches) (mm)		Length (inches) (mm)				
Modular Frogged	3-5/8	92	2-1/4	57	7-5/8	194	6.75	4.1	1.9
Modular Unfrogged	3-5/8	92	2-1/4	57	7-5/8	194	6.75	4.7	2.1
Standard Unfrogged	3-5/8	92	2-1/4	57	8	203	6.55	4.9	2.2
Engineer Modular Frogged	3-5/8	92	2-3/4	70	7-5/8	194	5.63	5.2	2.4
Engineer Standard Frogged	3-5/8	92	2-3/4	70	8	203	5.39	5.5	2.5





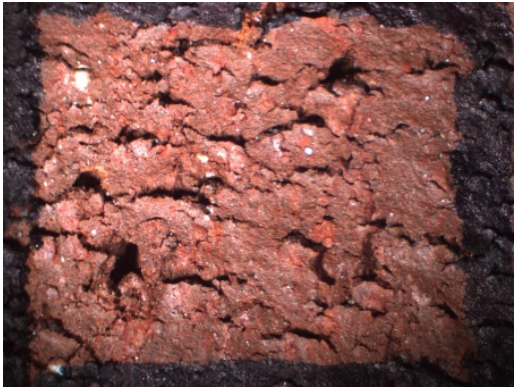
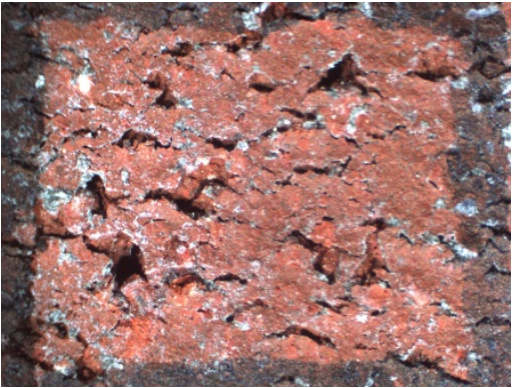
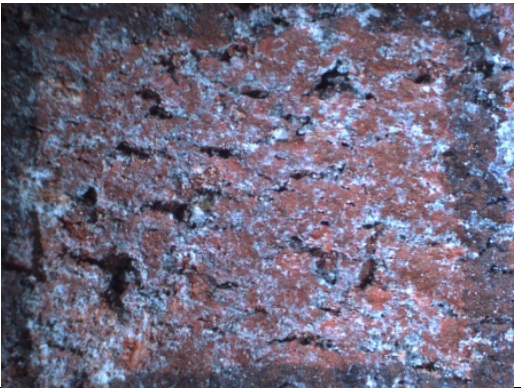



¹⁵² American Society for Testing and Materials, "ASTM C62-12: Standard Specification for Building Brick (Solid Masonry Units Made from Clay or Shale," doi:10.1520/C0062-12.





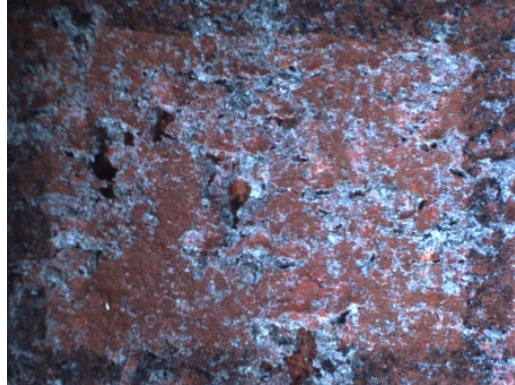

¹⁵³ "Glen-Gery Molded Brick Specification Sheet," Glen-Gery Brick, accessed March 14, 2013, <http://www.glenerybrick.com/pdf/4p4.pdf>.



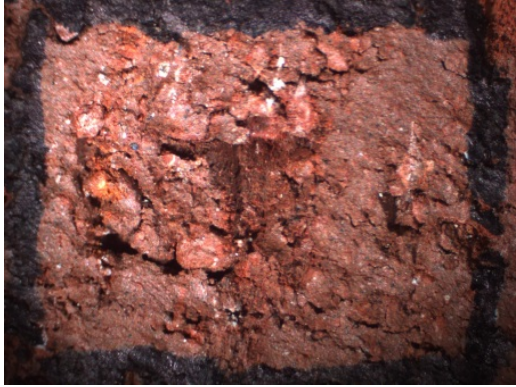

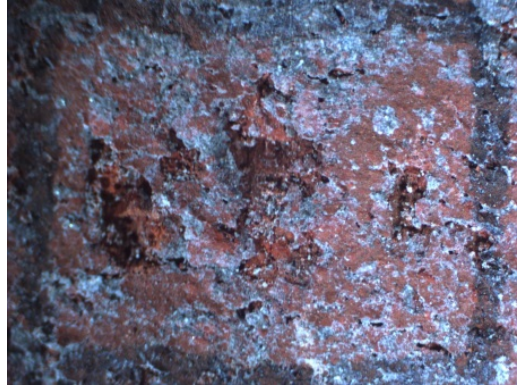
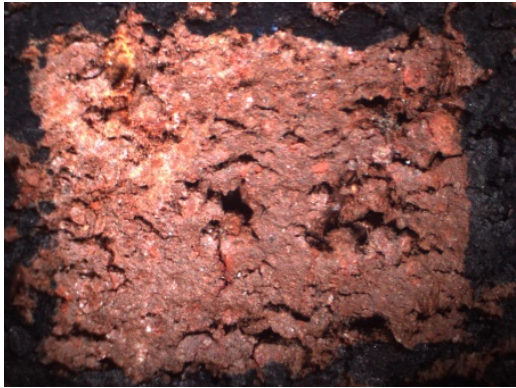
¹⁵⁴ Ibid., 3.

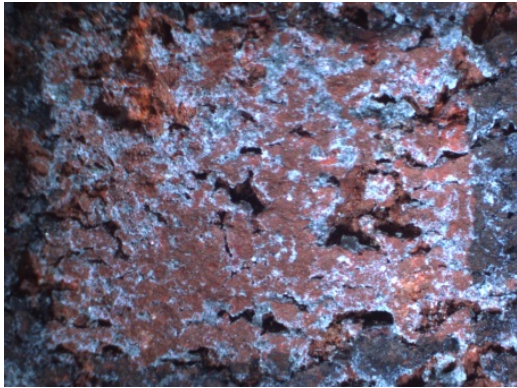
A.2 Microscope Photos

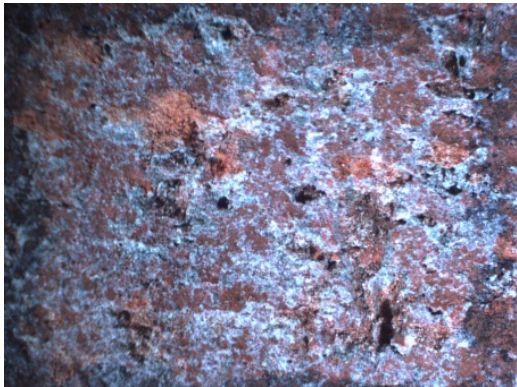
ID	Dry Specimen	After 1 st mortar application	After 2 nd mortar application
A1 - Stage 1			2 
A2 - Stage 1			

ID	Dry Specimen	After 1 st mortar application	After 2 nd mortar application
G1 - Stage 1	 A photograph of a dry, reddish-brown, porous material with a cracked and irregular surface texture.	 The same specimen after the first mortar application, showing a layer of white mortar coating the surface.	 The specimen after the second mortar application, with a thicker and more uniform white mortar coating.
G2 - Stage 1	 A photograph of a dry, reddish-brown, porous material with a cracked and irregular surface texture.	 The same specimen after the first mortar application, showing a layer of white mortar coating the surface.	 The specimen after the second mortar application, with a thicker and more uniform white mortar coating.
K1 - Stage 1	 A photograph of a dry, reddish-brown, porous material with a cracked and irregular surface texture.	 The same specimen after the first mortar application, showing a layer of white mortar coating the surface.	 The specimen after the second mortar application, with a thicker and more uniform white mortar coating.

ID	Dry Specimen	After 1 st mortar application	After 2 nd mortar application
K2 - Stage 1	 A photograph of a dry, reddish-brown, porous material specimen, likely a brick or tile, showing a rough, textured surface.	 A photograph of the same specimen after the first application of mortar, showing a layer of reddish-brown mortar applied to the surface.	 A photograph of the specimen after the second application of mortar, showing a more uniform and thicker layer of reddish-brown mortar.
B1 - Stage 1	 A photograph of a dry, reddish-brown, porous material specimen, similar to K2, showing a rough, textured surface.	 A photograph of the same specimen after the first application of mortar, showing a layer of reddish-brown mortar applied to the surface.	 A photograph of the specimen after the second application of mortar, showing a more uniform and thicker layer of reddish-brown mortar.
B2 - Stage 1	 A photograph of a dry, reddish-brown, porous material specimen, similar to K2, showing a rough, textured surface.	 A photograph of the same specimen after the first application of mortar, showing a layer of reddish-brown mortar applied to the surface.	 A photograph of the specimen after the second application of mortar, showing a more uniform and thicker layer of reddish-brown mortar.

ID	Dry Specimen	After 1 st mortar application	After 2 nd mortar application
J1 - Stage 1	 A photograph of a dry, reddish-brown, cracked surface, likely a brick or concrete specimen, showing a network of fine cracks.	 A photograph of the same specimen after the first mortar application. The surface is covered with a thick, greyish mortar layer, and the underlying cracks are still visible through the mortar.	 A photograph of the specimen after the second mortar application. The mortar layer is even thicker and more uniform, covering the surface more completely than in the first application.
J2 - Stage 1	 A photograph of a dry, reddish-brown, cracked surface, similar to J1, showing a network of fine cracks.	 A photograph of the specimen after the first mortar application. The mortar is applied, but there are some dark spots and irregularities in the coverage.	 A photograph of the specimen after the second mortar application. The mortar coverage is more uniform, though some dark spots remain.
C1 - Stage 2	 A photograph of a dry, reddish-brown, cracked surface, similar to J1, showing a network of fine cracks.	 A photograph of the specimen after the first mortar application. The mortar is applied, and the cracks are clearly visible through the greyish mortar.	 A photograph of the specimen after the second mortar application. The mortar coverage is more uniform, but the underlying cracks are still visible.



ID	Dry Specimen	After 1 st mortar application	After 2 nd mortar application
C2 - Stage 2	 A photograph of a dry, reddish-brown, porous material with a rough, cracked surface.	 A photograph of the same material after the first mortar application, showing a darker, more uniform surface with some white mortar residue.	 A photograph of the material after the second mortar application, showing a very dark, almost black surface with significant white mortar residue.
D1 - Stage 2	 A photograph of a dry, reddish-brown, porous material with a rough, cracked surface.	 A photograph of the same material after the first mortar application, showing a darker, more uniform surface with some white mortar residue.	 A photograph of the material after the second mortar application, showing a very dark, almost black surface with significant white mortar residue.
D2 - Stage 2	 A photograph of a dry, reddish-brown, porous material with a rough, cracked surface.	 A photograph of the same material after the first mortar application, showing a darker, more uniform surface with some white mortar residue.	 A photograph of the material after the second mortar application, showing a very dark, almost black surface with significant white mortar residue.



ID	Dry Specimen	After 1 st mortar application	After 2 nd mortar application
H1 - Stage 2	 A photograph of a dry, reddish-brown, cracked surface. The surface is highly textured with numerous small, irregular cracks and a rough, porous appearance.	 A photograph of the same surface after the first mortar application. The surface is now covered with a layer of light-colored mortar, which has filled some of the cracks and created a smoother, more uniform appearance.	 A photograph of the surface after the second mortar application. The surface is now even smoother and more uniform in color, with the mortar filling most of the cracks and creating a dense, layered structure.
H2 - Stage 2	 A photograph of a dry, reddish-brown, cracked surface, similar to H1. The surface is highly textured with numerous small, irregular cracks and a rough, porous appearance.	 A photograph of the same surface after the first mortar application. The surface is now covered with a layer of light-colored mortar, which has filled some of the cracks and created a smoother, more uniform appearance.	 A photograph of the surface after the second mortar application. The surface is now even smoother and more uniform in color, with the mortar filling most of the cracks and creating a dense, layered structure.
O1 - Stage 2	 A photograph of a dry, reddish-brown, cracked surface, similar to H1. The surface is highly textured with numerous small, irregular cracks and a rough, porous appearance.	 A photograph of the same surface after the first mortar application. The surface is now covered with a layer of light-colored mortar, which has filled some of the cracks and created a smoother, more uniform appearance.	 A photograph of the surface after the second mortar application. The surface is now even smoother and more uniform in color, with the mortar filling most of the cracks and creating a dense, layered structure.

ID	Dry Specimen	After 1 st mortar application	After 2 nd mortar application
O2 - Stage 2	 A photograph of a dry, reddish-brown, porous material with a rough, cracked surface.	 A photograph of the same specimen after the first mortar application, showing a layer of grey mortar covering the surface.	 A photograph of the specimen after the second mortar application, showing a thicker, more uniform layer of grey mortar.
L1 - Stage 2	 A photograph of a dry, reddish-brown, porous material with a rough, cracked surface.	<p>No mortar applied</p>	<p>No mortar applied</p>
P1 - Stage 2	 A photograph of a dry, reddish-brown, porous material with a rough, cracked surface.	 A photograph of the specimen after the first mortar application, showing a layer of grey mortar covering the surface.	 A photograph of the specimen after the second mortar application, showing a thicker, more uniform layer of grey mortar.

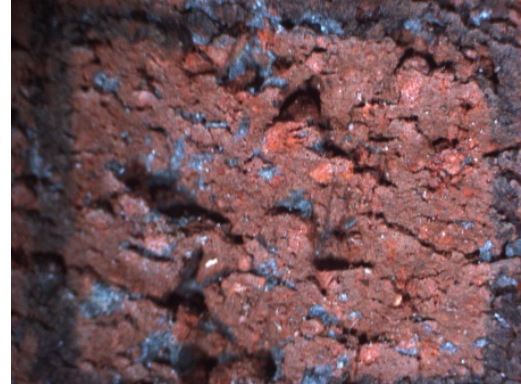
ID	Dry Specimen	After 1 st mortar application	After 2 nd mortar application
P2 - Stage 2	 A square, reddish-brown, porous material specimen with a rough, cracked surface.	 The same specimen as in the dry state, but with a thin, light-colored mortar layer applied to its surface.	 The specimen after a second mortar application, showing a thicker, more uniform layer of light-colored mortar covering the surface.
E1 - Stage 3	 A square, reddish-brown, porous material specimen with a rough, cracked surface.	No mortar applied	No mortar applied
E2 - Stage 3	 A square, reddish-brown, porous material specimen with a rough, cracked surface.	 The specimen after the first mortar application, showing a thin layer of light-colored mortar.	 The specimen after the second mortar application, showing a thicker layer of light-colored mortar.

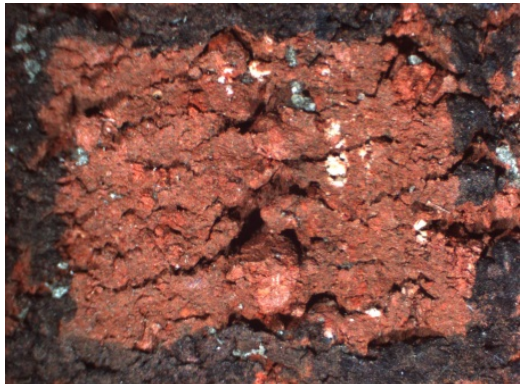
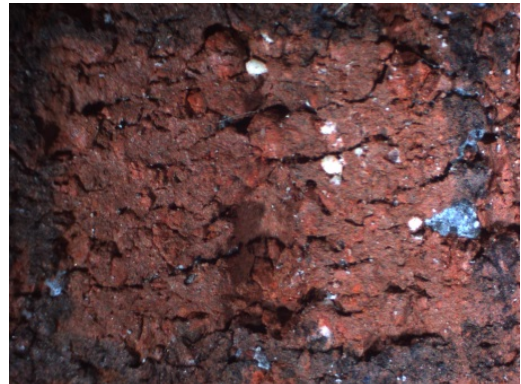
ID	Dry Specimen	After 1 st mortar application	After 2 nd mortar application
I1 - Stage 3		No mortar applied	No mortar applied
M1 - Stage 3			
M2 - Stage 3			

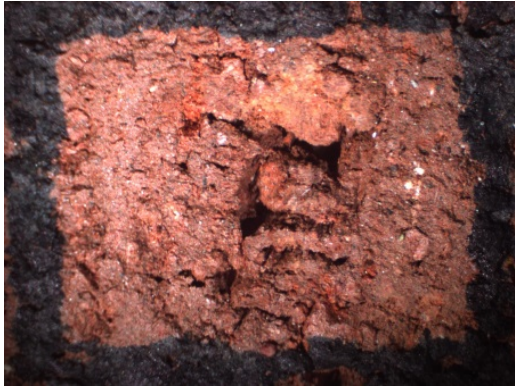
ID	Dry Specimen	After 1 st mortar application	After 2 nd mortar application
N1 - Stage 3	Photo not available		
N2 - Stage 3			
F1 - Stage 3			

ID	Dry Specimen	After 1 st mortar application	After 2 nd mortar application
F2 – Stage 3	 A photograph of a dry, reddish-brown, porous material specimen, likely a brick or tile, showing its natural texture and color.	 A photograph of the same specimen after the first application of a grey mortar. The mortar is visible as a darker, more uniform layer covering the surface of the specimen.	 A photograph of the specimen after the second application of mortar. The mortar layer is thicker and more uniform, covering the entire surface of the specimen.

Bibliography

- American Society for Testing and Materials. "ASTM C1329-12: Standard Test Methods for Sampling and Testing Brick and Structural Clay Tile." doi:10.1520/C1329_C1329M-12.
- American Society for Testing and Materials. "ASTM C1356-12: Standard Test Methods for Sampling and Testing Brick and Structural Clay Tile." doi:10.1520/C1329_C1329M-12.
- American Society for Testing and Materials. "ASTM C1437-07: Standard Test Method for Flow of Hydraulic Cement Mortar." doi:10.1520/C1437-07.
- American Society for Testing and Materials. "ASTM C1506-09: Standard Test Method for Water Retention of Hydraulic Cement-Based Mortars and Plasters." doi:10.1520/C1506-09.
- American Society for Testing and Materials. "ASTM C216-12a: Standard Specification for Facing Brick (Solid Masonry Units Made from Clay or Shale)." doi:10.1520/C0216-12A.
- American Society for Testing and Materials. "ASTM C270-12: Standard Specification for Mortar for Unit Masonry." doi:10.1520/C0270-12A.
- American Society for Testing and Materials. "ASTM C62-12: Standard Specification for Building Brick (Solid Masonry Units Made from Clay or Shale)." doi:10.1520/C0062-12.
- American Society for Testing and Materials. "ASTM C67-12: Standard Specification for Mortar Cement." doi:10.1520/C0067-12.
- American Society for Testing and Materials. "ASTM C91/C91M-12: Standard Specification for Masonry Cement." doi: 10.1520/C0091-12.
- American Society for Testing and Materials. "ASTM C952-12: Standard Test Method for Bond Strength of Mortar to Masonry Unit," doi: 10.1520/C952-12.
- American Society for Testing and Materials. "ASTM E72-10: Standard Test Methods of Conducting Strength Tests of Panels for Building Construction," doi: 10.1520/E0072-10.
- American Society for Testing and Materials. "ASTM E518-10: Standard Test Methods for Flexural Bond Strength of Masonry." doi:10.1520/E0518_E0518M-10.
- American Society for Testing and Materials. "ASTM E519-10: Standard Test Method for Diagonal Tension (Shear) in Masonry Assemblages." doi:10.1520/E0519_E0519M-10.
- American Society for Testing and Materials. "ASTM C1072-11: Standard Test Methods for Measurement of Masonry Flexural Bond Strength." doi:10.1520/C1072-11.
- American Society for Testing and Materials. "ASTM C1357-09: Standard Test Methods for Evaluating Masonry Bond Strength." doi:10.1520/C1357-09.

- Asfa-Wossen, Ledetta. "Binding a future for waste bricks." *Materials World* 19, no. 6 (2011): 12.
- Bailey, William G., John H. Matthys and Joseph E. Edwards. "Initial Rate of Absorption of Clay Brick considering Both Bed Surfaces in the As Received Condition and After Outside Exposure." In *Masonry: Components to Assemblages, ASTM STP 1063*, edited by John H. Matthys, 5-21. Philadelphia: American Society for Testing and Materials, 1990.
- Bidwell, T.G. *The Conservation of Brick Buildings: The Repair, Alteration, and Restoration of Old Brickwork*. Windsor, Berkshire: Brick Development Association, 1977.
- Binda, L., I. Papayianni, E. Toumbakari and R. van Hees. "Mechanical Tests on Mortars and Assemblages." In *Characterisation of Old Mortars with Respect to their Repair, RILEM TC 167-COM*, edited by C. Groot, G. Ashall and J. Hughes, 57-76. Bagnaux: RILEM Publications SARL, 2004.
- "Bond Strength in Masonry Construction." *Cement, Concrete & Aggregates Association of Australia Technical Notes*, no. 65 (2001).
- Borchelt, J.G., and J.A. Tann. "Bond Strength and Water Penetration of Low IRA Brick and Mortar." Paper presented at the Seventh North American Masonry Conference, South Bend, Indiana, 1996.
- Bourgès, Ann and Véronique Vergès-Belmin. "Application of fresh mortar tests to poutices used for the desalination of historical masonry." *Materials and Structures* 44 (2010): 1233-1240.
- Boynton, Robert S. and Kenneth A. Gutschick. "Bond of Mortar to Masonry Units: Factors Influencing Strength, Extent, and Durability of Bond." *National Lime Association*, 1964.
- "Brick Cleaning Manual." *Think Brick Australia* (2008). Accessed February 1, 2013
http://www.thinkbrick.com.au/assets/documents/technical_information/brickwork/TBR4978Cleaning-Masonry2HR1.pdf.
- "Brick Masonry Material Properties." *The Brick Industry Association Technical Notes on Brick Construction*, no. 3A (1992): 1-10.
- British Standards. "EN 1052-5: 2005 Methods of Test for Masonry: Determination of Bond Strength by the Bond Wrench Method."
- Broeksmit, Susan Begley and Anne T. Sullivan. "Dry-Press Brick: A Nineteenth-Century Innovation in Building Technology." *APT Bulletin* 37, no. 1, (2006): 45-52.
- Burnham, C.A. and C.T. Grimm. "Connotative Meaning of Visual Properties of Surfaces." In *Sensory Evaluation of Appearance of Materials, ASTM STP 545*, 54-69. Philadelphia: American Society for Testing and Materials, 1973.
- Callister, William D. *Materials Science and Engineering: An Introduction, 7th ed.* New York: John Wiley & Sons, 2007.
- Campbell, James W.P. *Brick: A World History*. London: Thames & Hudson, 2003.

- “Cleaning Brickwork.” *The Brick Industry Association Technical Notes on Brick Construction*, no. 20 (2006): 1-10.
- Coombs, John M. “Enhancement of masonry curriculums through development of a virtual laboratory.” Master’s thesis, University of Wyoming, 2007.
- Davison, J.I. “Effect of Temperature on Brick Suction.” *Journal of Testing and Evaluation* 10, no. 3 (1982): 81-82.
- De Vitis, N., A.W. Page and S.J. Lawrence. “Influence of Age on the Development of Bond Strength.” Paper presented at the 4th Australian Masonry Conference, Sydney, Australia, November 23-24, 1995.
- Eddy, Alan P. “Masonry in Retrospect: Mortar-Strength Experiments Conducted in France in 1834.” *APT Bulletin* 27, no.4 (1996): 16-17.
- Engineering Experimental Station. “Relative Adhesion of Mortars to New and Used Brick.” *University of New Hampshire*. Durham, 1935.
- Erdoğdu, Şakir. “Effect of Retempering with Superplasticizer Admixtures on Slump Loss and Compressive Strength of Concrete Subjected to Prolonged Mixing.” *Cement and Concrete Research* 35, no. 5 (2005): 907-912.
- Gabby, Brent A. “A Compilation of Flexural Bond Stresses for Solid and Hollow Non-Reinforced Clay Masonry and Portland Cement-Lime Mortars.” In *Masonry: Components to Assemblages, ASTM STP 1063*, edited by John H. Matthys, 235-247. Philadelphia: American Society for Testing and Materials, 1990.
- Galitz, Christopher L. “Variability in Brick Unit Test Results.” In *Masonry: Opportunities for the 21st Century, ASTM STP 1432*, edited by D. Throop and R.E. Klingner, 114-121. West Conshohocken: ASTM International, 2003.
- Gates, Robert E., Robert L. Nelson and Michael F. Pistilli. “The Development of Ready Mixed Mortar in the United States.” In *Masonry: Components to Assemblages, ASTM STP 1063*, edited by John H. Matthys, 123-142. Philadelphia: American Society for Testing and Materials, 1990.
- Gazzola, Edward, Dino Bagnariol, Janine Toneff and Robert G. Drysdale. “Influence of Mortar Materials on the Flexural Tensile Bond Strength of Block and Brick Masonry.” In *Masonry: Research, Application and Problems, ASTM STP 871*, edited by J.C. Grogan and J.T. Conway, 15-26. Philadelphia: American Society for Testing and Materials, 1985.
- Glen-Gery Brick. “Glen-Gery Color Mortar Blend.” Accessed March 14, 2013, <http://www.glengerybrick.com/pdf/4p1.pdf>.
- Glen-Gery Brick. “Glen-Gery Molded Brick Specification Sheet.” Accessed March 14, 2013, <http://www.glengerybrick.com/pdf/4p4.pdf>.

- Glen-Gery Brick. "The Making Process." Accessed March 14, 2013.
<http://www.glengerybrick.com/about/manufacturing/making.html>
- Grandet, B. "Physico-chemical mechanisms of the bond between clay and cement," *Proceedings of the 3rd International Brick and Block Masonry Conference*, Bonn, Germany, 1975.
- Grimm, Clayford T. "Durability of Brick Masonry: A Review of the Literature." In *Masonry: Research, Application and Problems, ASTM STP 871*, edited by J.C. Grogan and J.T. Conway, 202-234. Philadelphia: American Society for Testing and Materials, 1985.
- Grimm, Clayford T. "Masonry Failure Investigations." In *Masonry: Materials, Properties and Performance, ASTM STP 778*, edited by J.G. Borchelt, 245-260. Philadelphia: American Society for Testing and Materials, 1982.
- Grimm, Clayford T. "Water Permeance of Masonry Walls: A Review of the Literature." In *Masonry: Materials, Properties and Performance, ASTM STP 778*, edited by J.G. Borchelt, 178-199. Philadelphia: American Society for Testing and Materials, 1982.
- Groot, Casper. "Effects of Water on Brick-Mortar Bond." PhD diss., Delft University of Technology, 1993.
- "Guide to the Engineering Experiment Station Files, 1929-1968." University of New Hampshire Archives. Accessed December 10, 2012, <http://www.izaak.unh.edu/archives/holdings/ua8/ua8-1-1.shtml>.
- Harris, H.A. "Proposed Revisions to the Masonry Flexural Bond Strength Procedure." Paper presented at the Fifth North American Masonry Conference, Urbana-Champaign, Illinois, June 3-6, 1990.
- Holser, Peter J., Richard E. Klingner and John M. Melander. "Inter-Laboratory Study to Establish the Precision and Bias of Bond-Wrench Testing under ASTM C 1329 and C 1357." In *Masonry: Opportunities for the 21st Century, ASTM STP 1432*, edited by D. Throop and R.E. Klingner, 186-205. West Conshohocken: ASTM International, 2002.
- Industry Reference Guide*. 5th ed. Australia: Think Brick Australia, 2009.
- International Masonry Institute. "IMI Mission." Accessed March 20, 2013,
<http://www.imiweb.org/about/mission.php>.
- Kampf, Leo. "Factors affecting Bond of Mortar to Brick" In *Symposium on Masonry Testing, ASTM STP 320*, 127-142. Philadelphia: American Society for Testing and Materials, 1963.
- Khalaf, Fouad M. "New Test for Determination of Masonry Tensile Bond Strength." *Journal of Materials in Civil Engineering*, American Society of Civil Engineering, November/December 2005.
- Kidder, Frank E. *Kidder-Parker Architects and Builders Handbook: Data for Architects, Structural Engineers, Contractors and Draughtsmen*. New York: Chapman & Hall, 1931.

- Krauklis, Andrew T. "A Study of the Compatibility of Brick and Mortar for Maximizing Masonry Bond Strength." In *Masonry: Design and Construction, Problems & Repair, STP 1180*, edited by John M. Melander and Lynn R. Lauersdorf, 121-152. Philadelphia: American Society for Testing and Materials 1993.
- Laska, Walter A., Charles W. Ostrander, Robert L. Nelson and Colin C. Munro. "Research of Physical Properties of Masonry Assemblages Using Regional Materials." In *Masonry: Components to Assemblages, ASTM STP 1063*, edited by John H. Matthys, 339-349. Philadelphia: American Society for Testing and Materials, 1990.
- Lawrence, S. and H.T. Cao. "An Experimental study of the interface between brick and mortar." *Proceedings from the 4th North American Masonry Conference*. Paper presented at the 4th North American Masonry Conference, Los Angeles, California, 1987.
- Lipps, Tomas. "The Mortar Story." *Stonex Magazine* 8 (2008): 26-29.
- Louis, Michael J. "Prefabricated Brick Wall Panels: Economy of Nightmare?" In *Water Problems in Building Exterior Walls: Evaluation, Prevention and Repair, ASTM STP 1352*, edited by J.M. Boyd and M.J. Sheffler, 215-226. West Conshohocken: American Society for Testing and Materials, 1999.
- Mack, Robert C. and John P. Speweik. *Preservation Brief 2: Repointing Mortar Joints in Historic Masonry Buildings* (Washington D.C.: Cultural Resources, National Park Service, U.S. Department of the Interior, 1998).
- Maheri, Mahmoud R., F. Motielahi and M.A. Najafgholipour. "The effects of pre and post construction moisture condition on the in-plane and out-of-plane strengths of brick walls." *Materials and Structures* 44 (2011): 541-559. Accessed February 1, 2013. doi: 10.1617/s11527-010-9648-y.
- Matthys, John H. "Concrete Masonry Prism and Wall Flexural Bond Strength using Conventional Masonry Mortars." In *Masonry: Components to Assemblages, ASTM STP 1063*, edited by J.H. Matthys, 350-361. Philadelphia: American Society for Testing and Materials, 1990.
- McGinley, W. Mark. "An Evaluation of Bond Wrench Testing Apparatuses." In *Masonry: Esthetics, Engineering and Economy, ASTM STP 1246*, edited by Donald H. Taubert and Tim Conway, 100-115. Philadelphia: American Society for Testing and Materials, 1996.
- McGinley, W. Mark. "Flexural Bond Strength Testing – An Evaluation of Testing Procedures." In *Masonry: Design and Construction, Problems and Repair, ASTM STP 1180*, edited by John M. Melander and Lynn R. Lauersdorf, 213-216. Philadelphia: American Society for Testing and Materials, 1993.
- McGinley, W. Mark. "IRA and the Flexural Bond Strength of Clay Brick Masonry." In *Masonry: Components to Assemblages, ASTM STP 1063*, edited by John H. Matthys, 217-229. Philadelphia: American Society for Testing and Materials, 1990.
- Melander, John M. and John T. Conway. "Compressive Strengths and Bond Strengths of Portland Cement-Lime Mortars." In *Masonry: Design and Construction, Problems and Repair, ASTM STP*

- 1180, edited by John M. Melander and Lynn R. Lauersdorf, 105-120. Philadelphia: American Society for Testing and Materials, 1993.
- Moriconi, G., V. Corinaldesi and R. Antonucci. "Environmentally-friendly mortars: a way to improve bond between mortar and brick." *Materials and Structures* 36 (2003): 702-708.
- "Mortars for Brickwork- Selection and Quality Assurance." *The Brick Industry Association Technical Notes on Brick Construction*, no. 8b (2006): 1-10.
- "Mortars for Brickwork." *The Brick Industry Association Technical Notes on Brick Construction*, no. 8 (2008): 1-11.
- Packaging Service Company Incorporated. "Crown Muriatic Acid Material Safety Data Sheet." Accessed March 30, 2013, http://whatsinproducts.com/files/brands_pdf/9114_16025016%20MSDS%20Muriatic%20Acid.pdf
- Palmer, L.A. and D.A. Parsons. "A Study on the Properties of Mortars and Bricks and their Relation to Bond." *Bureau of Standards Journal of Research* 12, no.5 (1934).
- Pashina, Keith A. and Steven M. Talafous. "Common Sense and Masonry Repair." *Journal of ASTM International* 7, no. 6 (2010): 196-216. Accessed January 15, 2013. doi: 10.1520/JAI102727.
- Pavia S. and R. Hanley. "Flexural Bond Strength of Natural Hydraulic Lime Mortar and Clay Brick." *Materials and Structures* 43 (2010): 913-922.
- Ponce, Lucas G., Richard E. Klingner and John M. Melander. "Use of Ruggedness Testing to Develop an Inter-Laboratory Testing Protocol for Mortar-Cement Mortar." In *Masonry: Materials, Testing and Applications, ASTM STP 1356*, edited by R.L. Nelson and H.L. Francis, 89-104. West Conshohocken: American Society for Testing and Materials, 1999.
- Portland Cement Association. "Masonry Mortars." Accessed March 20, 2013. www.floridamasonry.com/resources/Section%20VI%20-%20PCA%20Masonry%20Mortars.PDF, 1.
- Rao, K. Venu Madhava, B.V. Venkatarama Reddy and K.S. Jagadish. "Flexural Bond Strength of Masonry Using Various Blocks and Mortars." *Materials and Structures* 29 (1996): 119-124.
- Raths, Donald C. "Preconstruction Brick Veneer Evaluation Testing." In *Masonry: Materials, Design, Construction and Maintenance, ASTM STP 992*, edited by H.A. Harris, 41-56. Philadelphia: American Society for Testing and Materials, 1988.
- Reda Taha M.M., A.S. El-Dieb and N.G. Shrive. "Sorptivity: a reliable measurement for surface absorption of masonry brick units." *Materials and Structures* 34 (2001): 438-445.
- "Replacement Brick." *The Brick Industry Association Brick Brief* (2011): 1-2.
- Ribar, J.W. and V.S. Dubovoy. "Investigation of Masonry Bond and Surface Profile of Brick." In *Masonry: Materials, Design, Construction and Maintenance, ASTM STP 992*, edited by H.A. Harris, 33-37. Philadelphia: American Society for Testing and Materials, 1988.

- Ribar, J.W. and V.S. Dubovoy. "Masonry Cements: A Laboratory Investigation." In *Masonry: Components to Assemblages, ASTM STP 1063*, edited by John H. Matthys, 85-95. Philadelphia: American Society for Testing and Materials, 1990.
- Ritchie, T. and J.I. Davison. "Factors Affecting Bond Strength and Resistance to Moisture Penetration of Brick Masonry." In *Symposium on Masonry Testing, ASTM STP 320*, 127-142. Philadelphia: American Society for Testing and Materials, 1963.
- "Salvaged Brick." *The Brick Industry Association Technical Notes on Brick Construction*, no. 15 (1988): 1-7.
- Sanders, John P. and Denis A. Brosnan. "The Effect of Void Area on Brick Masonry Performance." *Journal of ASTM International* 4, no. 1 (2007): 84-97. Accessed January 15, 2013. doi: 10.1520/JAI00593.
- Sarangapani, G., Reddy B.V. Venkatarma, and K.S. Jagadish. "Brick-Mortar Bond and Masonry Compressive Strength." *Journal of Materials in Civil Engineering* 17, no. 2 (2005): 229-237.
- Schuller, M.P, R.H. Atkinson and J.L Noland. "Structural Evaluation of Historic Masonry Buildings." *APT Bulletin* 26 no. 2/3 (1995): 51-61.
- Scolforo, Matthew J. and Hank Browne. "Acquisition and Properties of Brick for Historic Structure Preservation and Rehabilitation." In *Standards for Preservation and Rehabilitation, ASTM STP 1258*, edited by S.J. Kelley, 337-352. Philadelphia: American Society for Testing and Materials, 1996.
- Scorch, Jennifer, Norman R. Weiss, and John J. Walsh. "Comparative Laboratory Evaluation of Conservation Mortars," *APT Bulletin: Journal of Preservation Technology*, Association of Preservation Technology, January 2012.
- Sickels-Taves, Lauren B. and Michael S. Sheehan. "Specifying Historic Materials: The Use of Lime." In *Masonry: Opportunities for the 21st Century, ASTM STP 1432*, edited by D. Throop and R.E. Klingner, 3-22. West Conshohocken: ASTM International, 2002.
- Simpson, Gumpertz and Heger. "Field & Laboratory Testing." Accessed March 20, 2013, <http://www.sgh.com/who-we-are/>
- Simpson, Gumpertz and Heger. "Who We Are." Accessed March 20, 2013, <http://www.sgh.com/who-we-are/>
- Sugo, Heber, Adrian w. Page and Stephen Lawrence. "Influence of Age on Masonry Bond Strength and Mortar Microstructure." *Canadian Journal of Civil Engineering* 34, no. 34 (2007): 1433-1442.
- Suter, G.T., J. Vandenberg and L. Fontaine. "Bond Capacity of Mortars for Historic Structures." *APT Bulletin* 27, no. 4 (1996): 27-35.
- Suter, Gary T., Margaret L. Thomson and Lyne Fontaine. "Mortar Study of Mechanical Properties for the Repointing of the Canadian Parliament Buildings." *APT Bulletin* 29, no. 2 (1998): 51-58.

- Taylor-Firth, Alan and Ian F. Taylor. "A Bond Tensile Strength Test for use in Assessing the Compatibility of Brick/Mortar Interfaces." *Construction & Building Materials* 4, no. 2 (1990): 58-63.
- U.S. Department of the Interior, *The Preservation of Historic Architecture* (Guilford: The Lyons Press, 2004).
- Walker, Dan. "The Effect of Freezing and Thawing on the Flexural Bond Strength of Masonry." In *Masonry: Esthetics, Engineering and Economy, ASTM STP 1246*, edited by Donald H. Taubert and Tim Conway, 163-178. Philadelphia: American Society for Testing and Materials, 1996.
- Walloch, Craig T., Philip J. Press, Richard E. Klingner and Robert D. Thomas. "Increasing the Cost-Effectiveness of Interlaboratory Studies and Routine Comparative Testing: A Practical Example Involving Masonry Bond Strength." *Masonry: Opportunities for the 21st Century, ASTM STP 1432*, edited by D. Throop and R.E. Klinger, 206-223. West Conshohocken: ASTM International, 2003.
- Watson town Brick Company. "Product Lines: Atlantic Series." Accessed April 27, 2013, <http://www.watson townbrick.com/product-lines/Atlantic-Series-Brick>.
- Wood, S.L. "Flexural Bond Strength of Clay Brick Masonry." *The Masonry Society Journal* 13, no. 2 (1995).
- Wright, Bruce T., Rick D. Wilkins and George W. John. "Variables Affecting the Strength of Masonry Mortars." In *Masonry: Design and Construction, Problems & Repair, STP 1180*, edited by John M. Melander and Lynn R. Lauersdorf, 197-210. Philadelphia: American Society for Testing and Materials, 1993.
- Yorkdale, A.H. "Initial Rate of Absorption and Mortar Blend." In *Masonry: Materials, Properties and Performance, ASTM STP 778*, edited by J.G. Borchelt, 91-98. Philadelphia: American Society for Testing and Materials, 1982.
- Zhu, M. and D.D.L. Chung. "Improving Brick-to-Mortar Bond Strength by the addition of Carbon Fibers to the Mortar." *Cement and Concrete Research* 27, no. 12 (1997): 1829-1839.