

On: 19 March 2013, At: 14:20

Publisher: Taylor & Francis

Informa Ltd Registered in England and Wales Registered Number: 1072954 Registered office: Mortimer House, 37-41 Mortimer Street, London W1T 3JH, UK

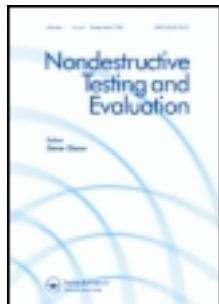

## Nondestructive Testing and Evaluation

Publication details, including instructions for authors and subscription information:

<http://www.tandfonline.com/loi/gnte20>

### AN EXPERIMENTAL STUDY OF AN ELECTRO-OPTICAL DISPLACEMENT SENSOR

MARIA Q. FENG<sup>a</sup>

<sup>a</sup> Department of Civil and Environmental Engineering, University of California, Irvine, CA, 92717, USA

Version of record first published: 10 May 2007.

To cite this article: MARIA Q. FENG (1996): AN EXPERIMENTAL STUDY OF AN ELECTRO-OPTICAL DISPLACEMENT SENSOR, *Nondestructive Testing and Evaluation*, 13:1, 5-14

To link to this article: <http://dx.doi.org/10.1080/10589759608953014>

PLEASE SCROLL DOWN FOR ARTICLE

Full terms and conditions of use: <http://www.tandfonline.com/page/terms-and-conditions>

This article may be used for research, teaching, and private study purposes. Any substantial or systematic reproduction, redistribution, reselling, loan, sub-licensing, systematic supply, or distribution in any form to anyone is expressly forbidden.

The publisher does not give any warranty express or implied or make any representation that the contents will be complete or accurate or up to date. The accuracy of any instructions, formulae, and drug doses should be independently verified with primary sources. The publisher shall not be liable for any loss, actions, claims, proceedings, demand, or costs or damages whatsoever or howsoever caused arising directly or indirectly in connection with or arising out of the use of this material.

## AN EXPERIMENTAL STUDY OF AN ELECTRO-OPTICAL DISPLACEMENT SENSOR

MARIA Q. FENG

*Department of Civil and Environmental Engineering,  
University of California, Irvine, CA 92717, USA*

*(Received 25 August 1995; in final form 10 October 1995)*

This paper presents the results of an experimental study on an innovative electro-optical fiber sensor developed for measuring the dynamic response of civil structures such as buildings and bridges, which can be used for non-destructive evaluation of structural systems. This electro-optical sensor employs an electric circuit, LC oscillator, in which inductance and capacitance are connected in parallel. The resonant frequency of the LC oscillator is modulated by the external displacement transmitted through the core of the induction solenoid. This frequency is detected from the optically-transmitted oscillatory signal and the LC oscillator is optically powered. Compared to the conventional optical fiber sensors developed so far, the proposed sensor has two significant advantages: 1) the sensing head is an electric circuit (rather than an optical fiber cable), which can sense a specific physical quantity without interference from miscellaneous effects and is expected to be much more durable than the sensing head made of optical fiber cable as seen in usual extrinsic optical fiber sensors; 2) the LC oscillator is a well understood and reliable circuit with its resonant frequency measurable and transmittable without attenuation or distortion through an optical fiber cable over a long distance to recording and other devices. These advantages make the sensor extremely simple to design and manufacture, durable, reliable, robust to use, and hence, more readily deployable in civil structural applications. A prototype electro-optical strain sensor has been developed and its static and dynamic characteristics were experimentally tested. This sensor was also installed on a steel frame to measure the dynamic strain response when subjected to seismic ground motions during a shaking table test. The experimental study using the prototype demonstrated excellent performance of the electro-optical sensor in terms of accuracy, wide frequency range, and other advantageous characteristics for civil structural applications.

**KEY WORDS:** Electro optics, displacement sensor, dynamic strain, civil structures.

### INTRODUCTION

An emerging technology, optical fiber sensing, has shown great potential for applications in civil structural systems for several reasons: An optical fiber sensor is dielectric so it will not suffer from the interference by electromagnetic fields, an unavoidable problem with conventional sensors. Optical fiber sensors and cables are lightweight. Electric short due to moisture does not happen to optical fiber cables, and hence, they do not need to be heavily water-proofed. Therefore, many of the cabling problems observed in the conventional sensor system do not exist or are significantly lessened in the optical fiber sensor system. Optical fiber sensors in certain configurations can sense quantities distributed over a linear distance and, in principle, even in two- and three-dimensional arrays. Due to the large commercial telecommunications market, the costs of key optical elements have been decreasing steadily. An optical fiber sensing

system will be significantly cheaper than its conventional counterpart once it is commercialized.

The advantages of optical fiber sensors closely match the requirements of civil structural applications. Over the last fifteen years or so, the optical fiber sensor technology has been gradually developed and applied particularly in electrical engineering fields. Major contributions include: optical current transducers using the Faraday effect (Udd, 1991), optical potential transducers using the Pockels effect (Kurosawa, 1990), and fiber-optic distributed temperature sensors using Raman scattering (Ogawa *et al.*, 1989). In civil engineering, most research performed to date has focused on obtaining qualitative measurements such as crack detection within concrete blocks. Pioneering research using quantitative measurements includes: measurement of strains in concrete beams employing embedded fiber optic Fabry-Perot sensors (Claus *et al.*, 1992) in a laboratory environment (Masri *et al.*, 1993); installation of multimode interferometric sensors in a building and a bridge to measure vibrations, concrete curing, and other parameters (Huston *et al.*, 1992, Fuhr, 1992, and Fuhr, 1993). Recent developments and applications of optic fiber sensors in civil engineering are summarized in (Ansari, 1993).

These exploratory studies have demonstrated the applicability of optical fiber sensors and provided basic knowledge specifically related to the installation or embedment techniques. However, these sensors were not originally developed for civil structures, and hence there are some difficulties in their direct applications to actual full-scale structures, although further efforts may alleviate some of these difficulties. For example, 1) these sensors usually detect the change in light intensity, phase delay, wave length, or interfered light mode pattern, and therefore in many instances they are too sensitive to measure dynamic response of civil structures which usually required a large measurement range, 2) the sensing heads of these sensors are optical fibers whose maximum capacities for sensing such quantities as strain and force are limited due to the fiber's physical strength. Therefore, the development of optical fiber sensors more suitable for civil infrastructure applications is urgently needed. This paper presents an unique electro-optical sensor which meets this urgent need.

## CONCEPT

The proposed electro-optical sensor is based on a completely different concept from those mentioned above. As shown in Figure 1, this sensor employs an electric circuit, an LC oscillator, which is composed, in parallel, of a solenoid with a built-in ferrite core as an inductance component  $L$  and a condenser as a capacitance component  $C$ . The resonant frequency of the circuit is given by

$$f = \frac{1}{2\pi\sqrt{LC}} \quad (1)$$

An external disturbance is translated into the displacement of the ferrite core inside the solenoid. The change in the displacement of the core results in the change in the

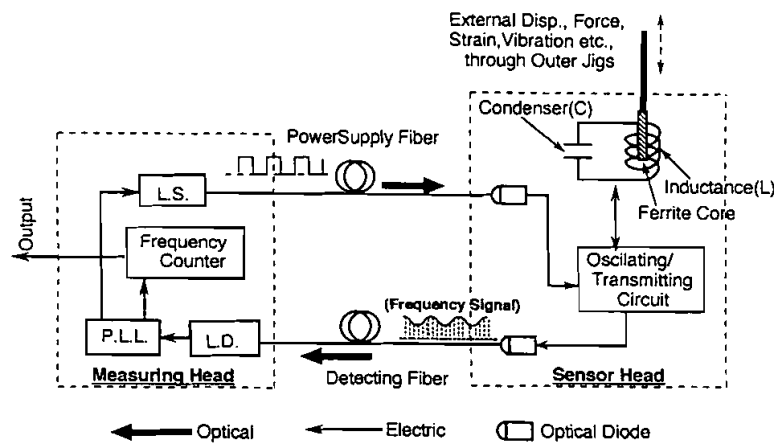

Figure 1 Conceptual Configuration of Electro-Optical Sensor.

inductance  $L$ , thus the change in the resonant frequency of the circuit  $f$ . Therefore, the resonant frequency of the LC oscillator can serve as an indicator of the displacement.

The LC oscillator is powered by a sequence of light pulses sent from a light source (LS). The frequency of the light pulses is instantaneously adjusted by a phase-locked-loop (PLL) circuit to the resonant frequency of the LC oscillator which varies with the change in the core displacement. The oscillatory voltage of the oscillator is translated by an optical diode into optical signals which are transmitted through an optical fiber cable into a light detector (LD) and then to a frequency counter. Based on the frequency, the displacement of the core is measured. Although the proposed sensor basically measures displacement, it can be easily modified to measure different physical quantities such as force, acceleration, and velocity.

The proposed electro-optical sensor can provide superior performance over the existing optical fiber sensors in a number of respects: 1) The LC oscillation is a well understood and reliable physical phenomenon and the resonant frequency can sensitively and accurately indicate the change in the core displacement; 2) The resonant frequency of the oscillator is a robust signal which can not be easily attenuated or deformed through the optical fiber transmission; 3) The sensing head is an electric circuit instead of an optical fiber cable which greatly broadens the possible range of measurement, and is expected to be significantly durable. These advantages make the proposed sensor accurate, reliable, and robust, and thus suitable for civil infrastructure applications.

## PROTOTYPE DEVELOPMENT AND EXPERIMENTAL STUDY

### *Prototype*

Based on the conceptual design described above, a prototype strain sensor was developed. This prototype can detect small displacement up to  $\pm 0.1$  mm. This range is appropriate for measuring strain of civil structures. The resolution is below  $0.01 \mu\text{m}$ .

The frequency of output optical signal is modulated within the range from 600 Hz to 1000 Hz. The power capacity of the excitation light is 5 mW and the power actually needed is less than 1 mW. The size of the prototype is  $\phi 36 \times 95$  mm and the weight is 120 gf. The sensor head has a stainless steel cover, so that it can be used in an embedded situation even in the presence of pH 12 alkaline concrete. The moving ferrite core is carefully installed not to touch the stationary inductance coil, through some mechanical detailing.

The following basic functions were confirmed through preliminary testing: 1) The displacement applied to the ferrite cores of the sensor can be translated into change in the resonant frequency of the LC oscillator; 2) The LC oscillator can be excited by the light pulse power with the resonant frequency of the oscillator which is instantaneously adjusted by the PLL circuit; 3) The resonant frequency of the LC oscillator can be accurately detected from the optically transmitted oscillatory signals.

### *Calibration*

The static relationship between the displacement and frequency of the LC oscillator was tested by applying an axial displacement to the core inside the solenoid of the LC oscillator. Photo 1 and Figure 2 show the experimental set-up of the calibration test where the prototype strain sensor is connected to a conventional encoder so that the displacement applied to the strain sensor is also measured by the encoder. The encoder can precisely measure displacement as small as  $0.1 \mu\text{m}$ . The relationship between the applied displacement  $x$  and the corresponding resonant frequency  $f$  of the LC oscillator

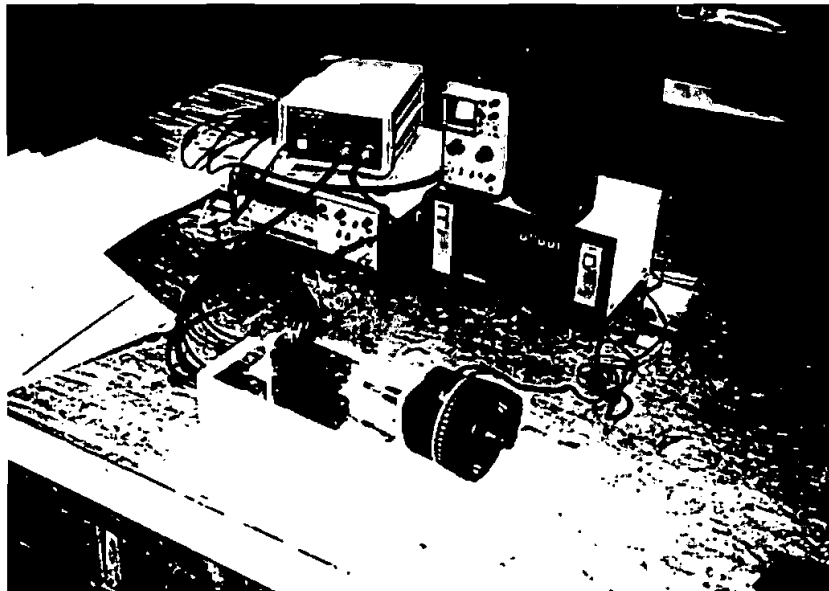

**Photo 1** Calibration of Eletro-Optical Strain Sensor.

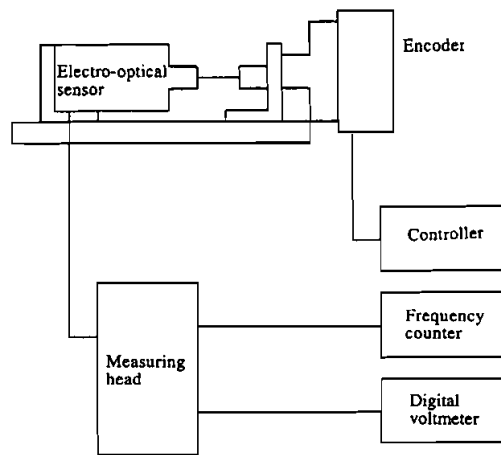

Figure 2 Calibration of Electro-Optical Strain Sensor.

is shown in Figure 3. The dots indicate the experimental data which can be modeled by the following equation as plotted in the solid line in the figure with a high correlation coefficient of 0.9999:

$$f = 1326.50 - \frac{4941.40}{\sqrt{x + 62.46}} \quad (1)$$

The repeatability of the testing data was confirmed.

The dynamic characteristics of the developed sensor are important for the future applications in which the response of civil structures are to be measured under dynamic external loads such as winds and earthquakes. In order to examine the dynamic characteristics, the sensor was excited by a hydraulic actuator at different. As shown

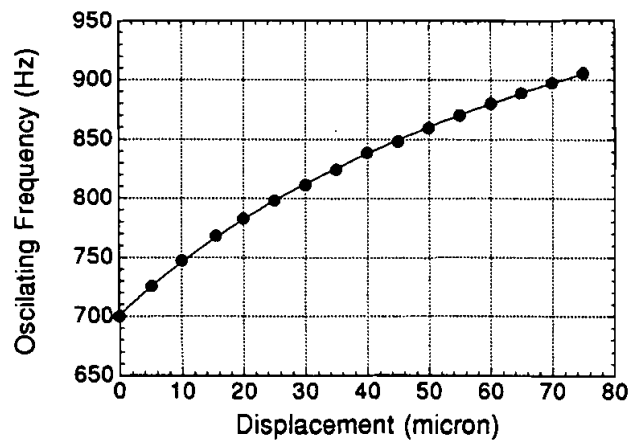

Figure 3 Relationship between Displacement and Frequency of LC Oscillator.

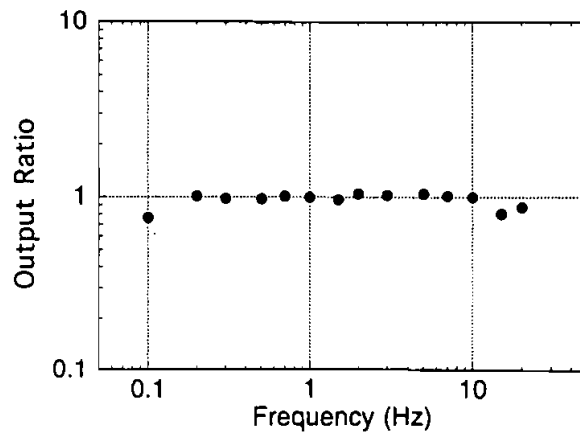

Figure 4 Dynamic Range

in Figure 4, the output ratio remains to be approximately 1.0 up to 20 Hz where the discrepancy reaches a 10% level. Therefore, this prototype can be used to measure the dynamic response at least up to 20 Hz which represents a sufficient range for civil structures. Other characteristics of the sensor useful for practical applications such as cross-sensitivity and drift will be tested and reported in the future.

#### *Shaking Table Testing*

The capability of the prototype electro-optical strain sensor to measure the dynamic structural response was further examined through a shaking table test. A two-story steel frame model, 1.9-meter tall and 1.3-meter wide, was installed on a shake table as shown in Photo 2 and Figure 5. The prototype sensor head was fixed on the bottom of the frame by bolts. The movable ferrite core of the sensor head was attached (not fixed,

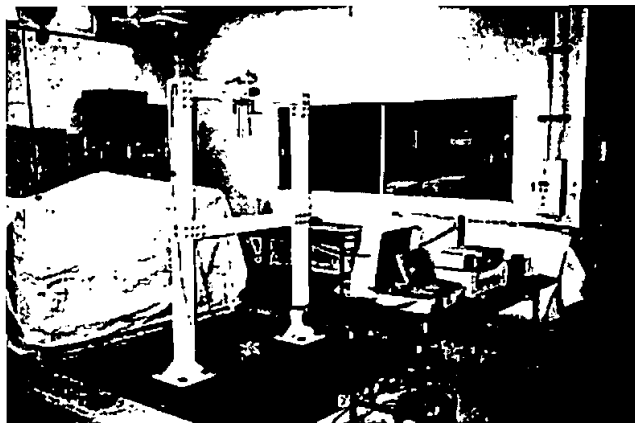

Photo 2 Shaking Table Testing.

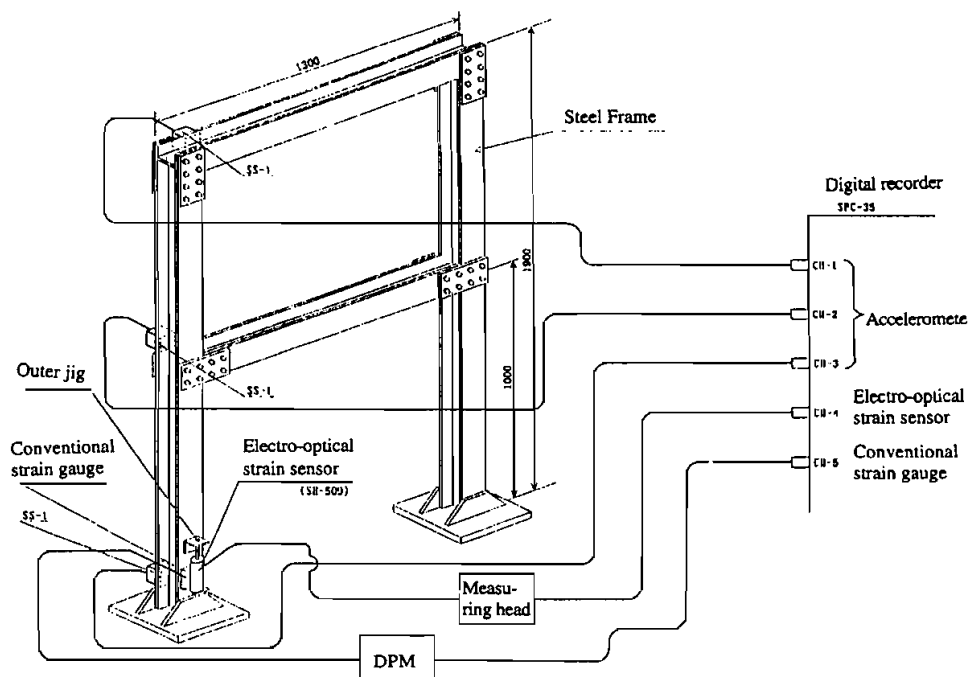

Figure 5 Shaking Table Testing.

this is important) to an outer jig which was fixed on the frame by bolts as well. This installation allows the deformation (strain) of the steel frame in any the direction to be translated into the axial displacement of the ferrite core. For the purpose of comparison, a conventional strain gauge was attached to the surface of the steel frame at the same location as the prototype strain sensor. The accelerometers were installed on the frame and the shaking table to monitor the response acceleration and the table input acceleration.

Different sinusoidal, random, and seismic excitations were applied to the shaking table and the strain response of the steel frame as measured by the electro-optical prototype sensors and the conventional strain gauge were compared. Among the seismic excitations, earthquake records such as El Centro [1940, NS], Shin-Fuji [1983, EW], and Kaihoku [1978, EW] were used. These motions have different intensities and different frequency contents. Figure 6 shows typical time histories of the strain response measured by the electro-optical sensor and the conventional strain gauge, together with the input table acceleration, respectively under a sinusoidal excitation (Figure 6(a)), a random excitation (Figure 6(b)), Shin-Fuji (Figure 6(c)) and Kaihoku (Figure 6(d)) seismic excitations. Excellent agreement between the measurements by the electro-optical and conventional sensors were observed under all excitations.

Shaking table tests confirmed the excellent dynamic characteristics as well as the significant accuracy of the electro-optical fiber sensors. It also demonstrated that these optical sensors can be easily installed in steel structures.



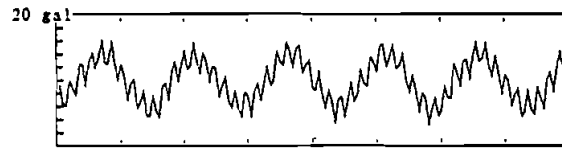
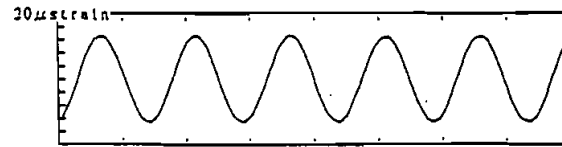
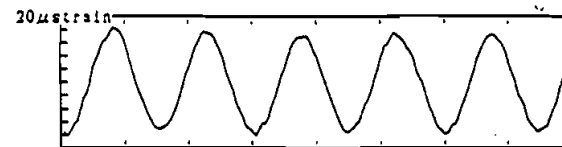

Table acceleration



Strain by conventional gauge



Strain by electro-optical sensor

(a) Sinusoidal Excitation

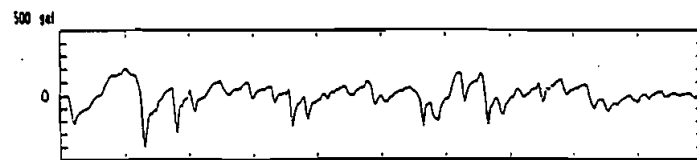
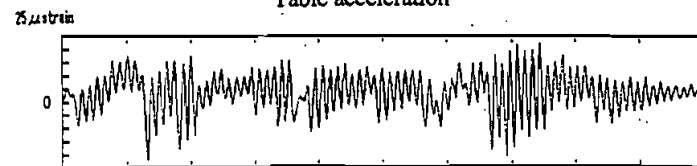
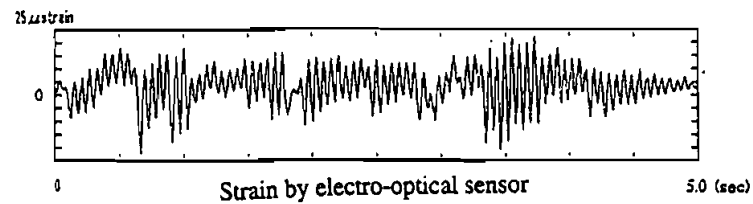

Table acceleration



Strain by conventional gauge



(b) Random Excitation

Figure 6 Comparison of Measurements by Electro-Optical and Conventional Sensors.

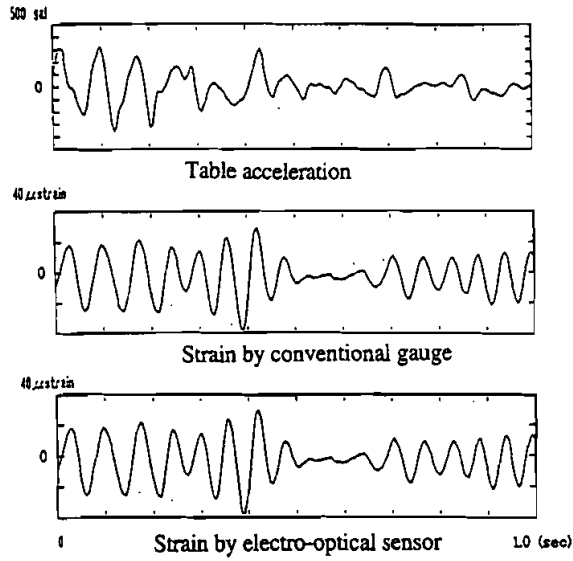

(c) Shin-Fuji Seismic Excitation

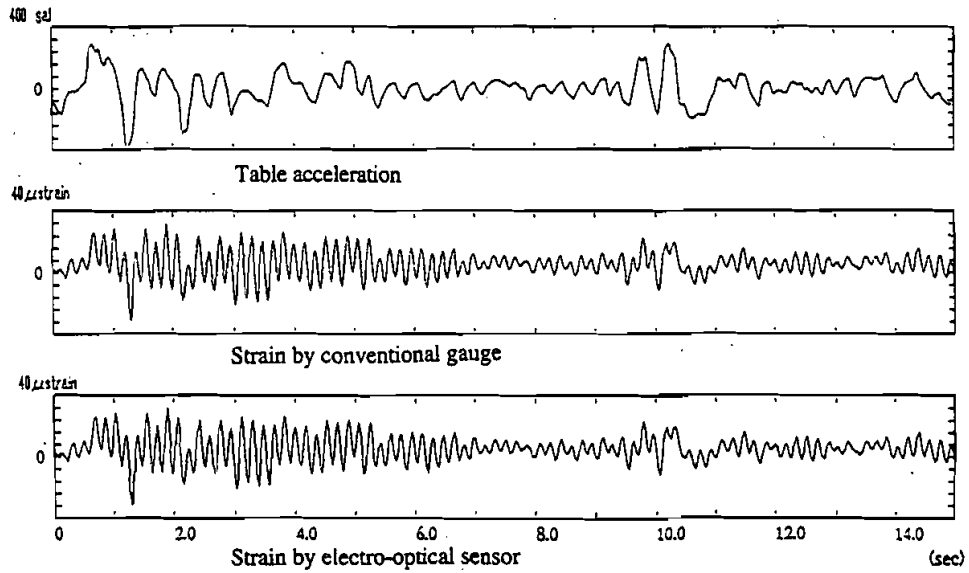

(d) Kaihoku Seismic Excitation

Figure 6 Comparison of Measurements by Electro-Optical and Conventional Sensors.

## CONCLUSIONS

An innovative electro-optical strain sensor has been developed and experimental studies on its static and dynamic performances, including a shaking table test with a steel frame, demonstrate that:

- 1) The LC oscillator is a very reliable electric circuit. Its resonant frequency precisely changes with the external dynamic displacement and can be reliably detected and transmitted by light.
- 2) The proposed electro-optical sensors can accurately measure the dynamic response of a steel structure.
- 3) It is easy to install the proposed sensor on a steel structure.

The unique concept of the sensor and the confirmed high level performance of the prototype make the proposed sensor extremely suitable for applications in civil structural systems. Potential applications include measurement of dynamic structure response for non-destructive evaluation of structural systems, and monitoring of structural response under wind and seismic excitations. In the near future, the author will perform field testing on a TV tower and a highway bridge to confirm the expected advantages of the proposed sensor such as immunity to electro-magnetic fields and durability, as well as to study potential problems including the influence of change in temperature.

### Acknowledgment

The work was supported by the National Science Foundation under Grant CMS-9411387 and monitored by Dr. Ken Chong. The author also wishes to acknowledge Dr. H. Suzuki of Tokyo Electric Power Co. and Mr. I. Yokoi of Tokyo Sokushin Co. for their cooperation throughout this research.

### References

1. F. Ansari (Editor), *Applications of fiber optic sensors in engineering mechanics*, ASCE, 1993.
2. R. O. Claus, M. F. Gunther, A. Wang and K. A. Murphy, "Extrinsic Fabry-Perot sensor for strain and crack opening displacement measurements from  $-200$  to  $900$  °c", *Smart Materials & Structures*, Vol. 1, pp. 237–242, 1992.
3. P. L. Fuhr, D. R. Huston, P. J. Kajenski and T. P. Ambrose, "Performance and health monitoring of the Stafford Medical Building using embedded sensors", *Smart Materials & Structures*, Vol. 1, PP. 63–68, 1992.
4. P. Fuhr and D. R. Huston, "Intelligent civil structures efforts in Vermont – An overview", *Smart Structures and Materials '93. Smart Sensing, Processing, and Instrumentation*, pp. 412–427, Albuquerque, February, 1993.
5. D. R. Huston, P. L. Fuhr and J. G. Beliveau, "Bridge monitoring with fiber optic sensors", *8th U.S. – Japan Bridge Engineering Symposium*, Chicago, IL, May, 1992.
6. K. Kurosawa, "Development and field tests of optical fiber sensors for electric power systems" (Invited Speaker), *Proceedings of the 7th Optical Fiber Sensors Conference*, pp. 67–72, December, 1990.
7. S. F. Masri, M. Mustafa, M. J. Vries and R. O. Claus, "Experimental study of embedded fiber optic strain gages in concrete structures", *Smart Structures and Materials '93, Smart Sensing, Processing, and Instrumentation*, pp. 428–434, Albuquerque, February, 1993.
8. K. Ogawa, H. Kawakami, T. Tsutsui and S. Yamamoto, "A fiber-optic distributed temperature sensor with high distance resolution" *Optical Fiber Sensors – Proceedings of the 6th International Conference*, pp. 544–551, Paris, September 18–20, 1989.
9. E. Udd (Editor), *Fiber optic sensors – an introduction for engineers and scientists*, Wiley-interscience, 1991.