

**Innovation and Technical Development
in the Japanese Steel Industry**

Occasional Paper No. 10

Nobuo Ohashi

Nobuo Ohashi is President and C.E.O. of Kawatetsu Techno-Research Co., Ltd.

This paper was featured at a faculty seminar presented by the Center on Japanese Economy and Business and the Sloan Technology Seminar Series, October 15, 1991 at the Columbia Graduate School of Business.

Occasional Paper Series
Center on Japanese Economy and Business
Graduate School of Business
Columbia University
March 1992

Abstract

The historical background of the steel industry in Japan and particularly its development since the Second World War is discussed with emphasis on technology. Although this background includes the factors related to political, economic, labor, management and technical staff capabilities, the continuous effort to improve technology and the modernization of facilities have been the fundamental forces behind the development of the Japanese steel industry. The production technology and product features of steel sheet, especially for automotive applications, are presented here by way of practical example. An extensive application of computer engineering in both of business- and process-control systems is introduced as a typical background of recent modernization of total manufacturing technologies. The research and development activities which support the improvement of technology and future tasks are also discussed.

I. Introduction

The origins of Japanese steelmaking technology can be traced to legendary times. In the historical era, "*tatara* blowing," a reduction technique using iron sand and charcoal materials, was developed and transmitted to subsequent generations of steelmakers. *Tamahagane*, the refined steel product of the *tatara* process, is prized even today as the starting material for traditional Japanese sword-smithing. Although steel was used through the middle ages in Japan, mainly in the manufacture of weapons such as swords and armor and later firearms, the introduction of European-style coke-process blast furnace steelmaking came only in 1901¹).

To secure the industrial base essential to a modern nation, Japan constructed a state-operated steelworks, which followed Western technical models in producing ship-building, construction, and rail materials as part of the nation's effort to promote the modernization of social and living conditions. Steel products were also developed and produced for the weapon and warship industries with the aim of establishing a modern military force. Because Japan has been involved in four major wars since 1894, armaments were of course a principal application of steel. Surprisingly, however, at the beginning of the Second World War in 1939, Japan's annual crude steel output was only 6.7 million tons, or 6.2% of its current level. In contrast, the United States had a crude steel output of 48 million tons in the same year²).

In the postwar period, great effort was put into the recovery of steelmaking capacity from an early date, since steel was a basic requirement for the reconstruction of the war-ravaged nation. In the difficult economic environment of these times and at considerable risk, Kawasaki Steel Corporation, acting on its own initiative, began construction of the first major postwar coastal integrated steelworks in 1951. Kawasaki's Chiba Works drew immediate attention and became a model case for the later development of the Japanese steel industry.

Thereafter, the Japanese steel industry constructed a series of large-scale integrated iron and steel works in coastal "green field" areas. Obsolete facilities damaged during the war were abandoned, and a radical modernization of equipment was undertaken. During this period of modernization, which lasted for approximately twenty years after the war, Japan introduced a number of advanced technologies from Europe and particularly from the United States, and put enormous effort into assimilating and improving these methods. The introduction of these technologies was essential to the development of the Japanese steel industry, and for this reason, we must express our deep appreciation to those in the European and American steel industry who willingly assisted us with the transfer of technology and ungrudgingly worked to ensure its successful introduction.

The Japanese steel industry since the end of the Second World War has operated as a private enterprise, as it continues to today. This fact deserves special emphasis for the contrast it offers to the major advanced nations of western European, the Communist bloc and the developing nations, where the steel industry either has been or is currently nationalized. The Japanese experience also suggests that the success of industry requires vigorous competition among private firms in the development of new technologies.

If this is the case, however, what reason can be given for the loss of vitality and stagnation seen in the American steel industry, which operates under the same free enterprise system? It is possible to point to a number of factors which are not related to technology development. These include the shareholder pressure for short term profit, which results in a lack of long-term management vision with respect to equipment investment practices, an adversarial relationship between labor and management, raw material transportation problems, and a shortage of capable technical people at the production site. To this could be added the very important fact that the American steel industry had already reached maturity prior to the revolution in steelmaking technology brought about by equipment upscaling and efficiency-related innovations in the 1950s and 60s, and thus failed to take advantage of these critical

developments. Many of these problems are not limited to steel, but are common to all manufacturers. However, it is in the steel industry, as the most representative example of capital intensive manufacturing, that the negative impact of such conditions can be most clearly seen.

As can be seen from these considerations, a direct comparison of the American and Japanese steel industries would be no simple matter. This paper will therefore limit itself to describing the development of the Japanese steel industry since the Second World War, and will then discuss current conditions and future prospects, with particular attention to matters of technology.

II. Historical Background and Present Status

The growth of crude steel production in Japan since the Second World War is shown in Figure 1³⁾. Excluding the first ten years, postwar crude steel production can be divided into three main periods. As shown in the figure, the first period of roughly twenty-eight years prior to the 1973 oil crisis was characterized by quantitative expansion. The remarkable expansion in steel output during this period demonstrated steel's importance as a basic material in the rebuilding of the nation and in Japan's subsequent era of high economic growth.

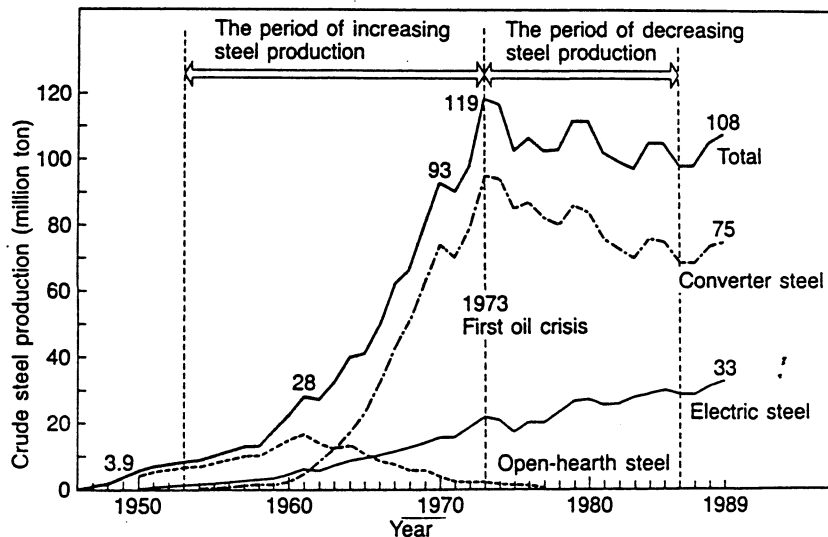

Fig.1 Progress of Crude Steel Production in Japan (1946-1989)

Until the 1973 oil crisis, annual increases in crude steel output were over 10%, and in fact exceeded the growth rate of Japan's GNP. To cope with the rapid quantitative expansion during this period, a series of large-scale integrated steelworks was constructed. The number of facilities with a current annual output of crude steel over 5 million tons is now fourteen nationwide.

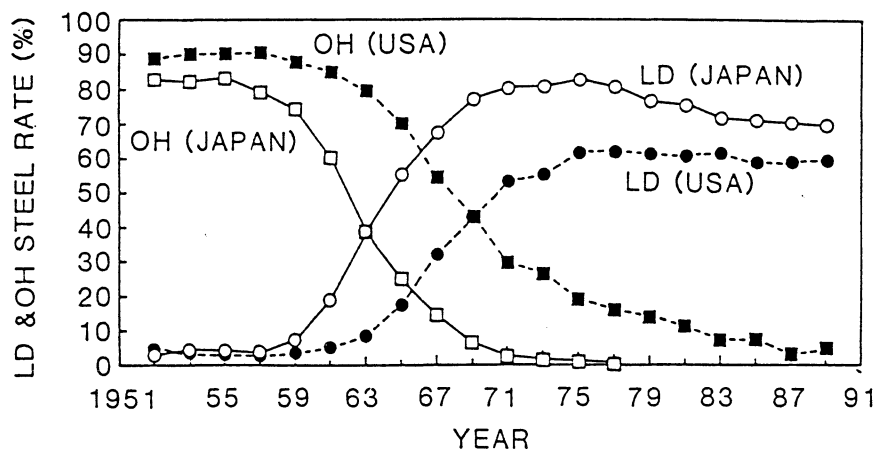

Fig.2 Progress of LD-Steel Rate (1951-1989)

The first postwar period also saw the progressive upscaling of blast furnaces. Of the twenty-six super-large furnaces with an inner capacity of over 4000 m³ now in operation around the world⁴⁾, the majority, or sixteen, are in Japan. As shown in Figure 2³⁾, the Japanese steel industry was also quick to make the switch to the basic oxygen converter for steel refining. By 1977, the conventional open hearth furnace had completely disappeared from Japan, and the top blowing pure oxygen converter represented mainstream practice. A corresponding development was the introduction of continuous casting. Steelmakers were extremely positive in the construction of continuous casting machines. As shown in Figure 3³⁾ the ratio of continuous casting to total crude steel output reached approximately 90% in 1984.

A 120 million ton record for annual crude steel production was achieved in 1973. However, following the first oil crisis the Japanese economy took a sudden turn and entered a period of stagnation and ultimately contraction. Crude steel showed the same downward trend as the economy in general during this second period in the Japanese

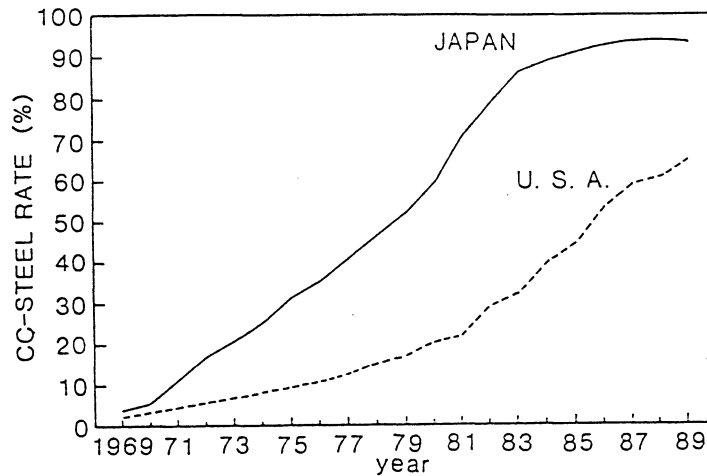

Fig.3 Progress of CC-Steel Rate (1969-1989)

steel industry's postwar history. Many of the tasks for technical development such as oil-less operation and energy savings were essentially reactive, although some major achievements such as process continuation contributed both to energy savings and to improved production efficiency. As always, intense effort was also put into higher product quality and the improvement of equipment performance. Changes in the GNP and crude steel production during this period are shown in Figure 4⁵⁾. Until the late 1980s, the trends in crude steel output and GNP growth rate remained very similar.

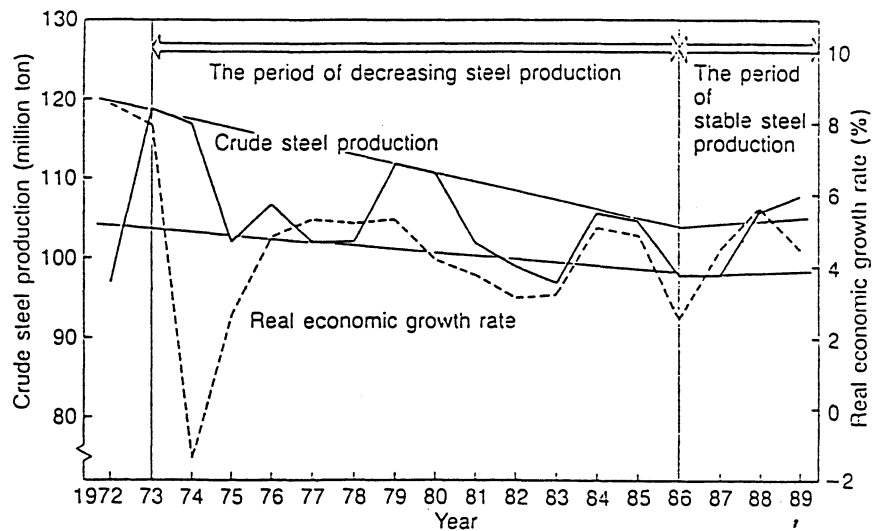

Fig.4 Progress of Crude Steel Production and Real Economic Growth Rate in Japan(1972-1989)

Then, following the G5 meeting at the New York Plaza Hotel in 1985, the yen entered an extended period of rapid appreciation

relative to the U.S. dollar. This "en-daka" crisis had a sharp impact on the Japanese economy, which fell into a relatively short but extremely deep recession. As an export industry, the steel industry was especially hard hit, since earnings of yen on dollar-denominated sales were cut by almost half. Tremendous effort was put into the downsizing of operations through the elimination of excess and inefficient capacity and accompanying reductions in manpower. Drastic cost-cutting measures enabled the Japanese steel industry to survive the crisis, but as Japan's steelmen looked to the future, they concluded that there was little hope for a return to the kind of broad expansion which had characterized the high growth years prior to 1973. While seeking to minimize further drops in output, they therefore began laying the foundations for diversification into nonsteel areas of business where continuing corporate growth would be possible, and thus entered the third period of their postwar history.

Although the Japanese steel industry has been heavily influenced by social and economic events during the 45 years since the end of the war, and has experienced hardship as well as prosperity, it is noteworthy that the industry has never wavered in its commitment to regular investment in the improvement of facilities. A comparison with the record of the American steel industry is given in Figure 5³).

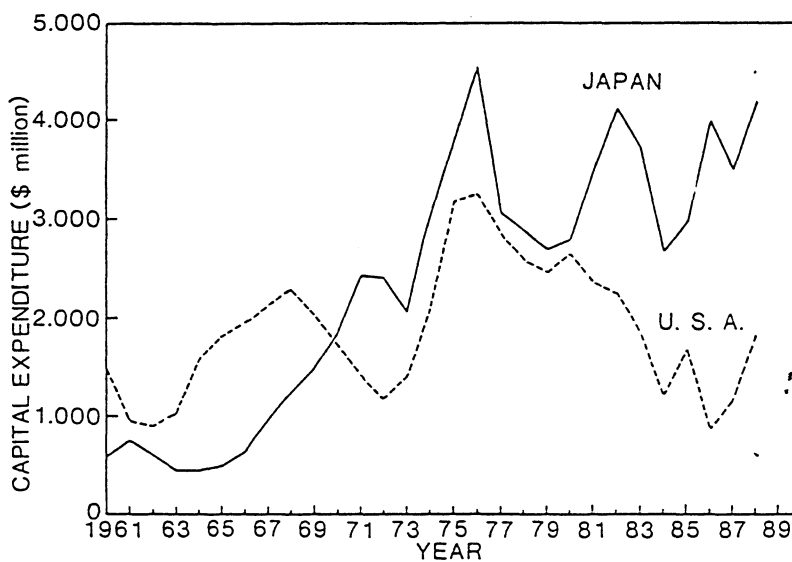

Fig.5 Transition of Capital Expenditure (Steel-related)

During the postwar period, the indebtedness of Japanese steelmakers has grown to a very large sum, while the equity ratio has remained at a low figure somewhere above 10%. Admittedly, customary business practices and a shareholder attitude which permits this type of financial situation are immensely helpful to an industry such as steel which requires enormous amounts of funding. But, it is equally true that the Japanese steel industry has used this opportunity to modernize equipment and aggressively introduce new technology. This type of long range thinking with regard to facilities has been essential to the establishment of a sound, productive corporate structure.

By 1988, Japan had emerged from the *en-daka* crisis, and domestic demand was pushing renewed economic growth. Because the strongest areas of the new expansion were the automotive and construction sectors, the steel industry also enjoyed a strong recovery. These conditions are expected to continue for several years, with crude steel output remaining stable at the 105-110 million ton per year level. Japan's major steel companies are now operating at near full capacity and are reporting good earnings, but to ensure that earnings remain adequate through the recession predicted during the 1990s, efforts to improve financial soundness are underway. For example, various measures have been undertaken to raise the present equity ratio of 25-30% to the 50% level.

On the other hand, since 1982 the major automakers of Japan have transplanted a considerable amount of their capacity to the United States. In concert with this movement, the principal Japanese steel producers have also established a presence in the American market, generally through capital participation in existing mills and technology transfer. The most important joint ventures relationships with American and Canadian steelmakers are shown in Table 16). The main products of these ventures are cold rolled and coated steel sheet for automotive application, and the scale of their operations is growing annually.

Table 1 Main Joint Ventures of Japanese and Foreign Major Steel Companies (1990)

Year (start)	Japanese Company	Degree of Stake	Partner	Joint Company	Project * (annual production capacity : 10,000MT unit)
JUL/87 SEP/89	NSC	40% 50%	Inland St. Inland St.	I. N. Tec I. N. Kote	Cold (100) CGL(80), EGL (80)
AUG/84 SEP/90	NKK	50% 40%	N I I National St. Dofasco (CANADA)	National Steel D. N. N. - Galvanising	Steelmaking (535) CGL (40)
JUL/84 MAY/89	Kawasaki St.	50% 50%	Rio Dose (BRAZIL) Armco Inc.	CSI ASC-LP	Flat-product-making(180) Steelmaking(480)
JAN/85 MAY/89	SMI	40% 50%	LTV LTV	L. S. EG L. S. II-EG	EGL(40) EGL(80)
MAY/89 OCT/89	Kobe St.	50% 50%	USX USX	USS-Kobe Steel AZ-Tec	Pipe, Bar, (270) CGL (54)
JUN/84	Nisshin St.	67%	W.P.Steel	Wheeling-Nisshin	CGL (28)

* Cold ; Cold-Rolled steel sheet , CGL ; Continuous Galvanizing Line,
EGL ; Electric Galvanizing Line.

In response to the requirements of the automotive industry, steelmakers have worked for the last forty years to improve quality and reduce cost, and are now using advanced technologies to provide a wide range of premium products including extra-deep drawing steels and various types of plated and/or coated steel sheets. The Japanese steel industry's current line of products is shown in Figures 6 and 7, by type and application⁷⁾⁴⁾. Among the total domestic consumption of steel products in Japan, civil engineering and construction products occupy approximately half of the entire mix, but auto applications account for about 18% of the total and hold the largest share of any single application.

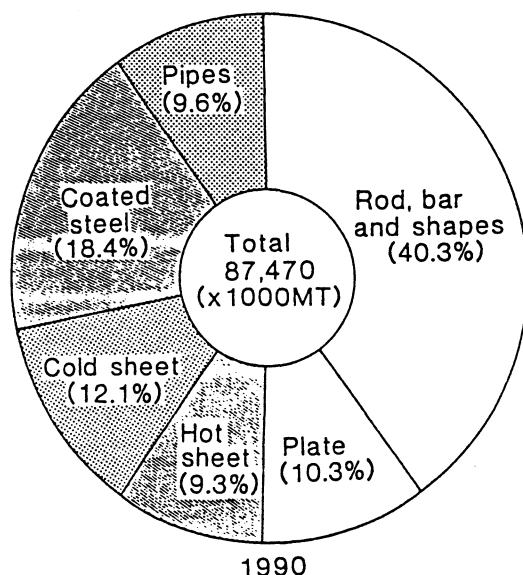

Fig.6 Shipment of Ordinary Rolled Products of Japan (1990)

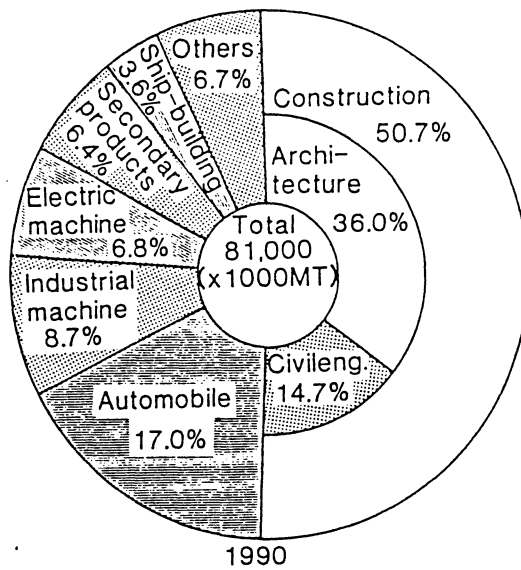

Fig.7 Consumption of Ordinary Rolled Steel Product by Sector in Japan (1990)

In view of the great importance of automotive-use steel sheets and their centrality to the development of new technology, this paper will discuss the current level of Japanese steel manufacturing technology mainly in terms of sheet products for automotive applications.

III. Technical Innovation

Technical innovation in upstream manufacturing processes, particularly in the refining and casting processes, is essential to achieving the quality levels required for automotive applications. Japan's major steelworks had completed the changeover to basic oxygen furnace refining by 1977, but as shown in Figure 8⁸⁾, the

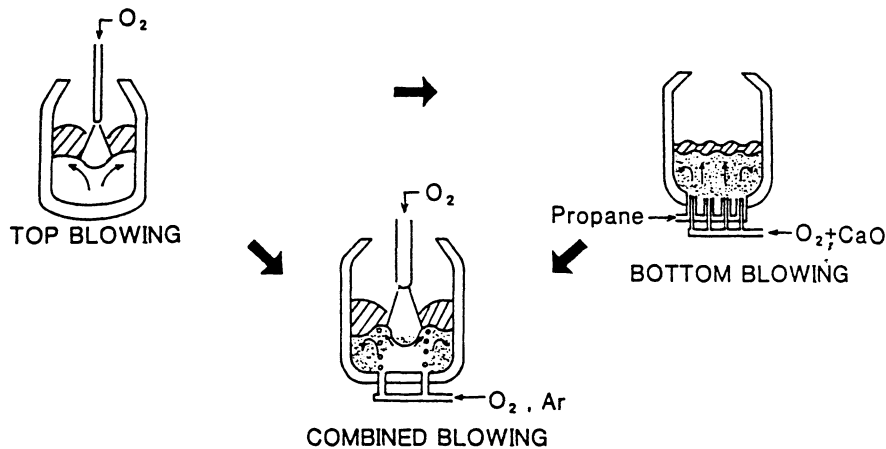

Fig.8 Progress of LD-Converter in Japan

equipment adopted was initially the simple top-blowing converter. The first bottom-blowing unit was introduced from U.S. Steel Corp. in 1977 at Kawasaki Steel's Chiba Works. After having experiences with these two types of furnaces, combined top-and-bottom blowing vessels were developed. Most converters now used in Japan are of the combined type.

Since 1977, a number of improvements have been made in the design of the converter vessel itself, in refractory materials and refractory application practices, and in the design of the oxygen lance and furnace bottom nozzles, contributing greatly to the improvement of steelmaking efficiency and reduced unit consumption of raw materials and refractories, all of which are useful in prolonging the furnace life up to several thousand heats. Figure 9 shows the reductions in the unit consumption of steelmaking refractories over the last 18 years⁹⁾.

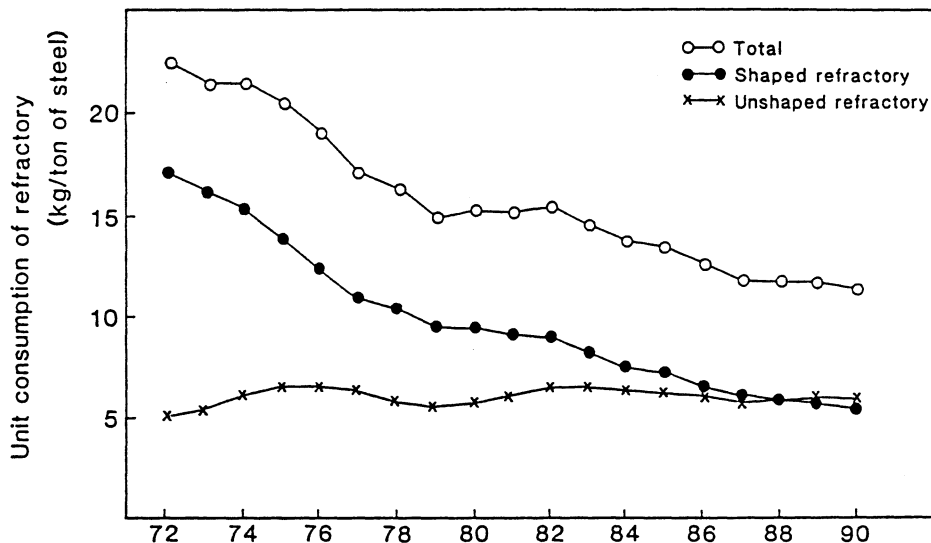

Fig.9 Trend of Unit Consumption of Refractories for Steelmaking in Japan

A more fundamental change in refining philosophy has also occurred in recent years. As shown in Figure 10⁵⁾, the conventional refining function has been separated into a series of independent processes which comprised of hot metal pretreatment between the blast furnace and converter, converter refining proper, and secondary refining after converter blowing. Hot metal pretreatment includes desiliconization (de-Si), dephosphorization (de-P), and desulfurization

(de-S), while secondary refining is used for degassing (to reduce the oxygen and hydrogen content of the steel), purification, and secondary decarburization. The role of the converter, therefore, has been simplified to two functions, decarburization and temperature control. Simplification of the converter function has improved refining efficiency, virtually eliminated the need to reblow heats to achieve target chemistries, and reduced refining times, giving the steelmaker better control over scheduling in the subsequent continuous casting process and making it possible to achieve very high continuous-continuous casting ratios.*

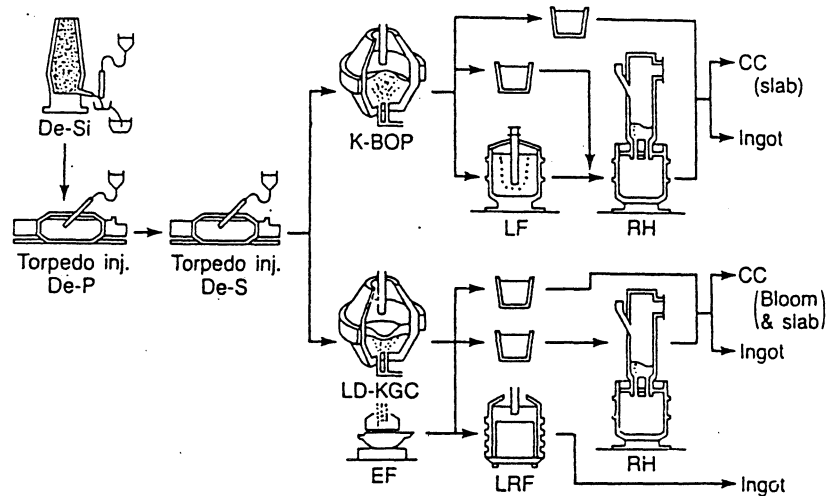

Fig.10 Flexible Steelmaking System with Pre- and Post-Treatment System (Kawasaki Steel)

De-Si is typically performed at the blast furnace runner, but improvements in blast furnace operation make it possible to reduce the Si content even of untreated hot metal to 0.2-0.3%. Lower Si levels in the hot metal facilitate the de-P and de-S operations, which are performed in the torpedo car by flux injection through a lance. Because de-P and de-S are respectively oxidation and reduction reactions, which stand in inverse relation, the two operations have

*The term "continuous-continuous casting" means the successive casting of molten steel charges, including those with differing chemistries, in an unbroken strand which is cut into slabs at appropriate points to produce material for specific customer orders.

normally been carried out at separate stations. With better fluxes and deslagging techniques, however, it is now possible to conduct them in series in a single operation, and P contents of 300 ppm and S contents of 100 ppm have been achieved in routine practice.

Converter operation has been fully automated, with oxygen blowing control based on hot metal data and the data from a substance which is immersed in the molten steel during refining. Sensors are installed in the substance to measure actual carbon and oxygen levels and the temperature of the bath, and this data is put into a computer, making possible precise control of refining conditions in real time. This type of control is making it possible to achieve both blow-end chemical composition and temperature targets without interrupting the refining operation. The simultaneous hit rate for both targets in each heat is close to 100%, and reblowing has been virtually eliminated.

Secondary refining is used to reduce the oxygen and hydrogen contents of the molten steel and thus prevent non-metallic inclusions and internal defects of products. Recently, as shown in Figure 11⁵⁾, the injection of oxygen into the vacuum chamber of the degasser has been introduced to obtain the more complete decarburization required for the ultralow carbon steels (20-30 ppm C) which are an essential material for the production of extra-deep drawing quality

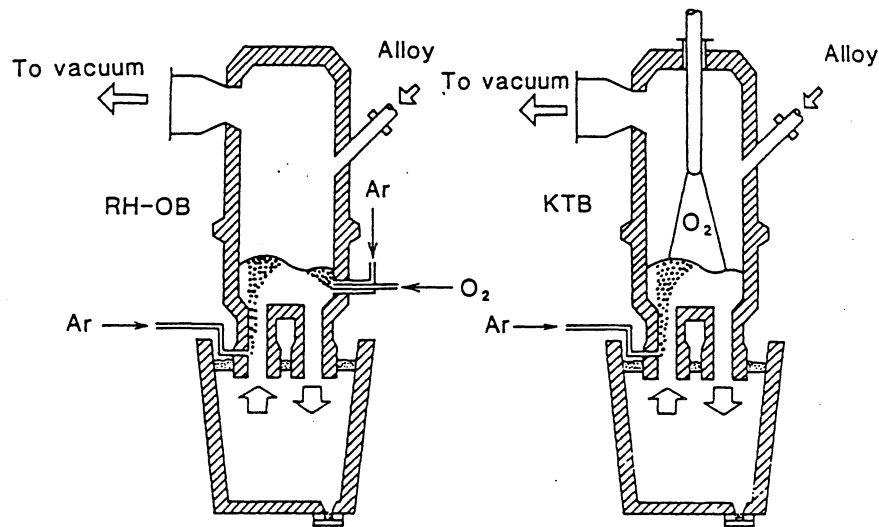

Fig.11 RH-OB (Nippon Steel) and KTB (Kawasaki Steel) Systems Developed for Decarburization for Interstitial Free Steel

steel sheets for automotive use. Further, the addition of alloying elements, such as Al, Ti, Nb, B, etc., at this stage allows precise control of what is termed "microalloying," in which alloy contents are measured at the 10 ppm level or less.

Continuous casting is currently applied to 95.3% of all crude steel¹⁰). For practical purposes, this figure represents 100% of the materials which can in theory be continuously cast, since the only exceptions are certain specialty steels and large forgings which cannot be produced by continuous casting because of their shape. Because continuous casting is the final upstream process which has a major effect on the internal quality and surface properties of steel, stable and precise control of the operation is absolutely essential.

In the area of continuous casting technology, precise control of the flow of molten steel is now possible as a result of numerous improvements in the construction of the tundish, and in the design of the long nozzle used in teeming from the ladle and the immersion nozzle used in the CC machine mold.

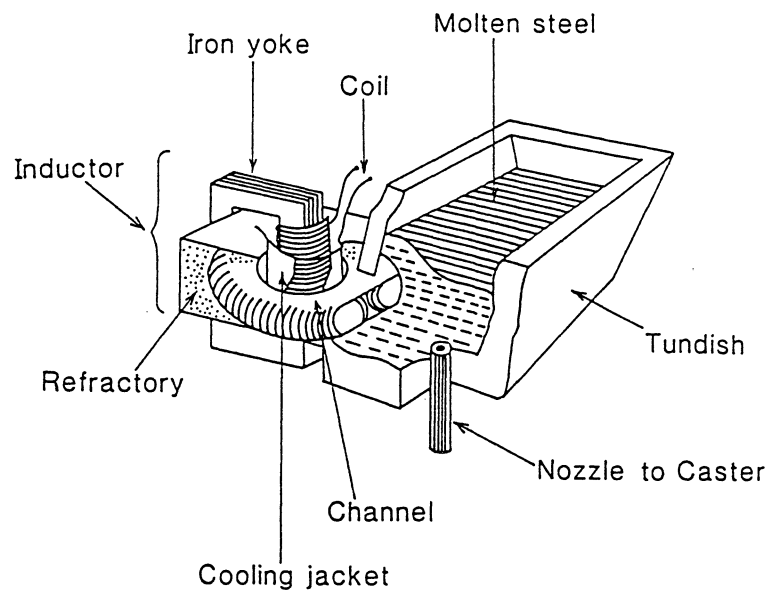

Fig.12 Principle and Construction of Induction Heater for Molten Steel in Tundish (Kawasaki Steel)

Kawasaki Steel has also developed a proprietary-design induction heater for molten steel in the tundish in order to maintain the temperature of the material during casting. By compensating for

temperature drops which occur at the beginning of teeming and at the intermediate stage while waiting to begin a succeeding heat, this device is useful in maintaining stable casting conditions. An example is shown in Figure 12¹¹). A technique for ensuring a perfect argon seal of the molten steel meniscus during casting is also essential for preventing secondary oxidation. Using these techniques, it is possible to reduce the oxygen content of the steel product to under 10 ppm, as required for bearing steels and similar products. A representative sealing technique for the continuous casting machine is shown in Figure 13¹²).

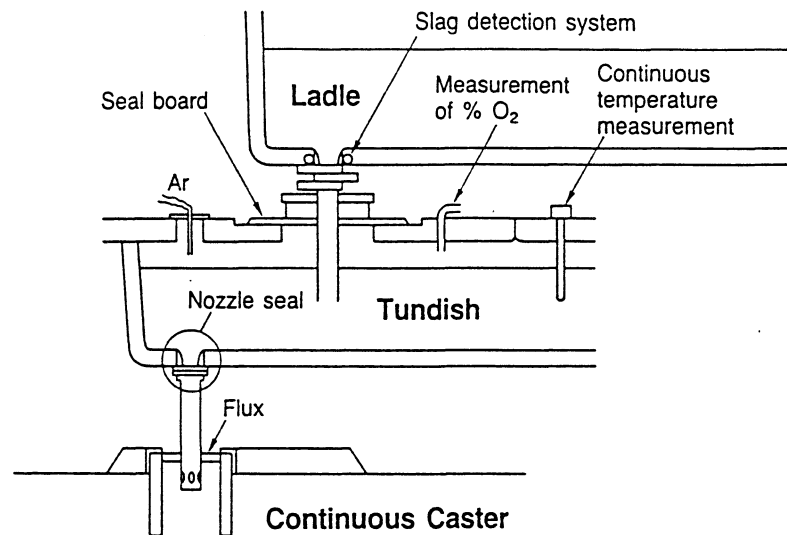

Fig.13 Schematic Drawing of Sealing Technique for Casting of Molten Steel (Kawasaki Steel)

Other important techniques applied to the continuous caster include mold width changing during casting, high frequency mold oscillation, meniscus level control, improvement of flux composition during teeming, and break-out prediction. These techniques, taken as a comprehensive technology, have made "endless" continuous casting possible, and a nonstop record of 800 charges has already been achieved.

In order to predict the flow of the molten steel in continuous casting, experiments were conducted with a full-size water model, and high-level fluid dynamics simulations were made using a super computer. Molten steel flow control systems based on these techniques are extremely important in floating up nonmetallic inclusions to the meniscus of the molten steel. This practice is

necessary to achieve a level of cleanliness which will eliminate the surface and internal defects that would otherwise appear in hot and cold rolled products. One method of controlling the flow of molten steel in the mold, as shown in Figure 14⁵, is magnetic braking, which is applied from outside the mold.

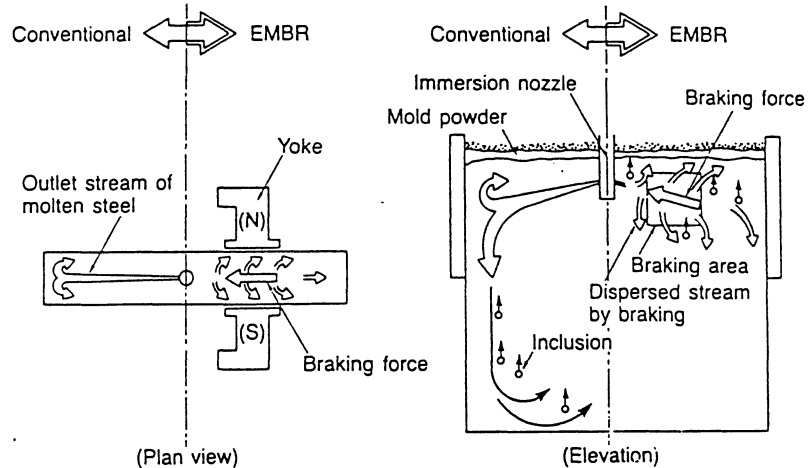

Fig.14 Electro-Magnetic Braking (EMBr) System Developed by Kawasaki Steel and ASEA for Flow Control of Steel Melt in CC Mold

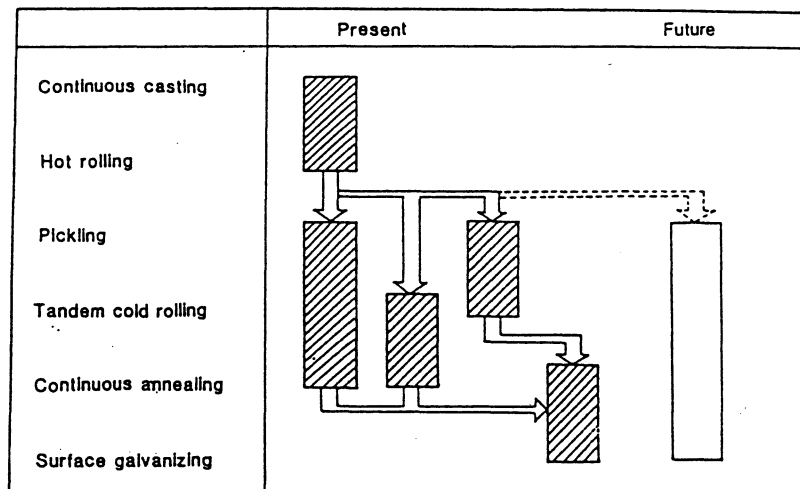

Fig.15 Concept of Continuation and Linkage of Processes from Continuous Casting through Galvanizing

In recent years, the adoption of completely new technologies has been realized not only in upstream processes, but also in downstream processes starting with the hot strip rolling. The linkage of equipment and operation, the establishment of automatic process control, maintenance techniques, and control systems for the flow of materials have been an essential factor in technical innovation. Equipment linkage, generally known as process continuation, includes

various combinations of equipment such as the continuous casting machines and hot strip mill, the pickling line and cold rolling and/or annealing lines, and the linkage of these latter facilities to final processes such as skinpass rolling and slitting, as shown in Figure 15⁹). All of these process linkages have produced major advantages in terms of reduced unit energy consumption, increased material yield, better uniformity of product quality and shape, reduced manpower requirements, and improved material flow.

Linkage of the casters and hot strip mill means either hot rolling of the cast slab immediately upon delivery from the CC shop or charging of high temperature slab into the reheating furnace. The resultant energy savings are shown in Figure 16¹³). Ten years ago, the average unit energy consumption for hot rolling in Japan was 332×10^3 kcal/ton; the current average is 259×10^3 kcal/ton, and one mill has established a record of 50×10^3 kcal/ton by CC-DR¹⁴).

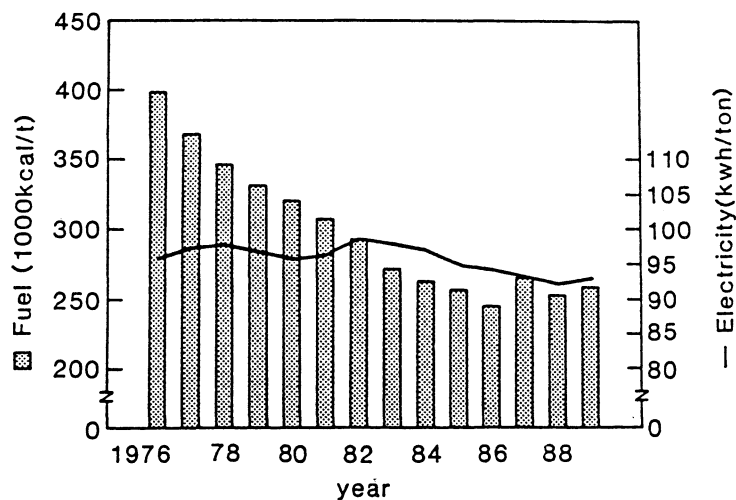

Fig.16 Trend of Energy Consumption in Hot Strip Rolling in Japan (1976-1989)

A major problem in the production of sheet products is the large number of size categories, since dimensional changes frequently have an adverse effect on efficiency. In past practice, trimming was necessary in the final process in order to meet the various product width requirements, and even though mold width changing was used during casting, the number of width changes was excessive. For this reason, Kawasaki Steel's Mizushima Works developed a unique, horizontal-type Sizing Press which is installed immediately ahead of

the roughing mill of the hot strip line. This equipment allows free control of slab width reduction within a range of up to 300 mm. A general diagram is shown in Figure 17⁵⁾.

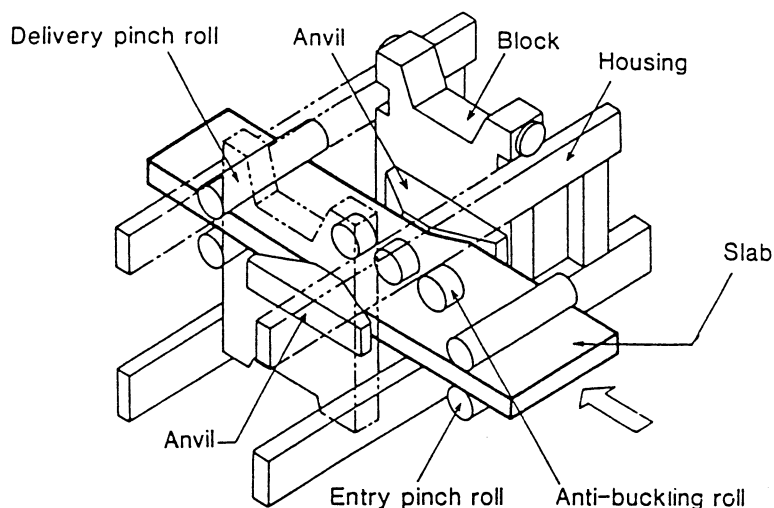

Fig.17 Slab Sizing Press Applied to Hot Strip Rolling Process (Kawasaki Steel)

The Sizing Press is designed to handle heavy unit-weight slabs as large as 210 mm in thickness and 2300 mm in width, and to operate in synchronization with the speed of the hot rolling mill. An additional feature is that this method of width reduction does not produce dog-bone deformation at the edges of the slab. Because CC mold width changing can be conducted in 300 mm steps when the Sizing Press is used, the number of slab widths required at the casting stage has been reduced to fewer than ten, resulting in a striking improvement in caster efficiency¹⁵⁾.

Remarkable progress has been made in hot and cold rolling equipment in recent years, and it is now possible to achieve a high level of precision in rolling under difficult conditions. Greater rigidity of the mills themselves and the adoption of hydraulic screwdown devices in place of conventional electric motor-driven screw units have sharply improved the speed of response in gauge control. A variety of techniques has also been developed to minimize thickness deviations in the widthwise direction, as shown in Figure 18¹⁶⁾: lateral shifting of the work rolls in the four-high mill and of the idler rolls in the six-high mill, a roll bending function in which pressure is applied to the roll chocks, and special design of the rolls themselves.

Precise dimensional control is thus possible in response to the width and thickness of the material being rolled and its deformation resistance¹⁷⁾.

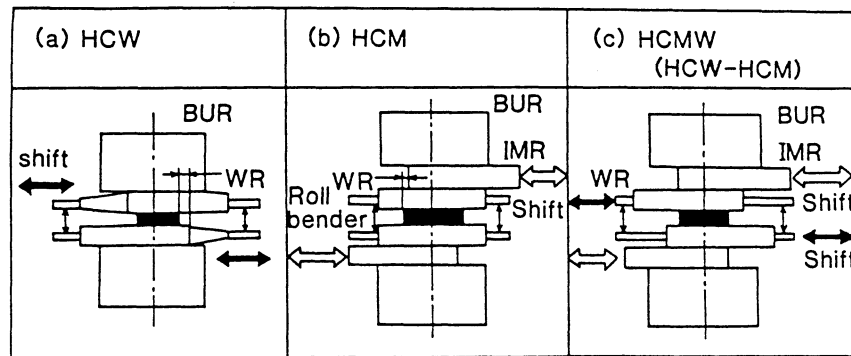

Fig.18 Schematic Diagram of Various Crown-control Rolling Mills

In addition, rolling mills have adopted many sensors for the measurement of temperature, load, and dimensions, and the information obtained by these sensors is used in computer control systems which include sophisticated software techniques. These control systems and the continuation of the rolling operation itself have resulted in a remarkable improvement in the accuracy of product sheet thickness and width dimensions. For example, the rolling accuracy of auto-use sheet (0.6 to 0.8 mm thicknesses) is $\pm 10 \mu\text{m}$, while that of tinning material (0.2 to 0.3 mm) is $\pm 5 \mu\text{m}$ ¹⁸⁾.

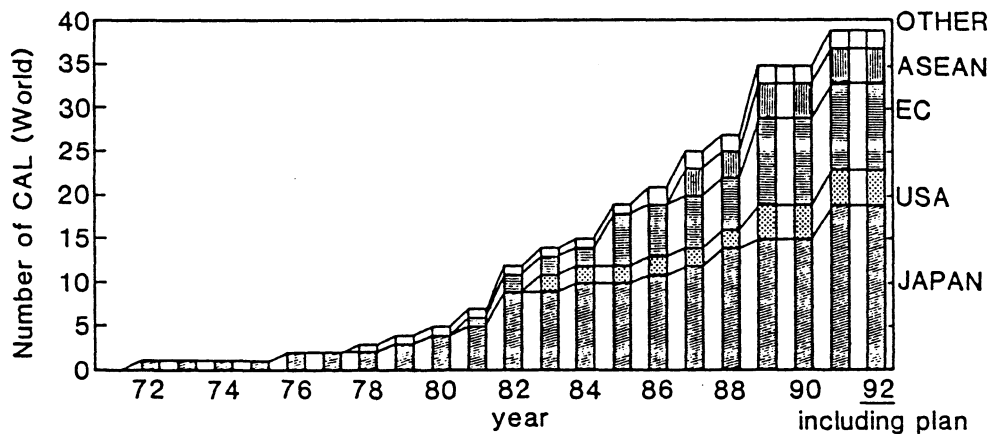

Fig.19 Progress of CAL Use (1972-1992)

The continuation of equipment in downstream processes after cold rolling is also progressing rapidly. One striking case is the successive construction of continuous annealing lines (CAL) since 1972, as illustrated in Figure 19¹⁾. At present, almost all steel sheet

materials for automotive applications are produced by the CAL process, which has had a positive effect on both the level and consistency of product quality. The most modern CALs for automotive sheet (0.5 to 1.2 mm thicknesses) operate at line speeds of approximately 500 mpm, while CALs for ultra-thin tinning materials can be operated at 900-1000 mpm.

Table 2 CGLs and EGLs at Major Steel Companies in Japan (Oct./1990 ; including under construction)

Company	CGL		EGL	
	No.	prod. cap.	No.	prod. cap.
Nippon Steel	11	3,100,000	7	1,800,000
Kawasaki steel	#7	1,620,000	3	1,100,000
N K K	5	1,380,000	5	1,050,000
Sumitomo Metal	5	1,300,000	3	750,000
Kobe Steel	2	600,000	2	600,000
Total	30	8,000,000	20	5,300,000

prod. cap. ; annual production capacity (ton)

include Kawatetsu Kohan

Table 3 Surface-Treated Steel Sheets Used for Automobiles

AUTO-MAKER	MAIN SURFACE-TREATED STEEL SHEETS
JAPANESE MAKER : A	EG (20/20), ZNO (30/30,+1 μ)
: B	EG (20/20), HD (45/45), HD (60/60), HDH (60G/45A)
: C	EG (30/30), EG (20/20), HD (45/45), HD (60/60), ZNO (30/30,+1 μ)
: D	EG (30/30), ZNO (30/30,+1 μ)
: E	EG (30/30), EG (40/40), HD (45/45), HD (60/60), HDH (60G/45A)
AMERICAN MAKER : A	HDH (100G/30A), GA (50/50), HD (100/100)
: B	EG (60/60), EG (60/60), EG (60/20), EG (100/100)
: C	EG (100/0), EG (70/70), HD (100/100), HD (70/70)

key-note : EG;Electrogalvanized, HD;Hot dip galvanized,

ZNO; ZnNi alloy + organic, HDH:HD/Alloy,

GA; ZnFe (Galvannealed - Hot dip or Electro) .

(x/y ; coating thickness of outer/inner surfaces, gr/m²)

Recently, various types of plated and/or coated steel sheets have found wide use as corrosion resistant materials for auto bodies. Leading-edge technologies have demonstrated their capabilities in the electrogalvanizing lines (EGL) and continuous hot-dip galvanizing lines

(CGL) used in Zn and Zn alloy coating. The equipment in service in Japan is shown in Table 2¹⁹). Some lines are capable of applying two or more types of alloy or compound alloy coatings, and depending on the case, organic coatings, in a single line. The variety of plated and coated steel sheets used in automotive applications is shown in Table 3²⁰).

A high level of computer control is applied to the operation of the equipment used in all of these annealing and coating processes. A variety of new techniques has been developed and adopted to ensure stable, high-speed operation under the widely varying temperature conditions which characterize CALs and CGLs. Precision control of point-to-point strip tension within the line and the development of roll configurations and sensors to maintain proper strip centering are important examples.

Stable operation of each item of equipment is an absolutely essential precondition for successful, trouble-free continuation and synchronization of two or more facilities. A high level of maintenance and diagnostic technology is necessary for this purpose. Rationalization of the material flow up- and downstream of the process is also important in order to avoid increased levels of in-plant inventory. In sum, not only will process continuation fail to demonstrate the desired results if a high level of peripheral technology is not applied to all areas, but the probability of line stoppage and costly breakdowns will also increase significantly.

IV. Extensive Application of Advanced Computer Engineering

Wide-ranging application of computer technology has been indispensable to the development of the Japanese steel industry. For example, with increase in output, the daily management of processes in the works and the technologies in each production process have become decidedly more complex, and head office administration of plants at widely separated locations has become an enormous undertaking. In both cases, the tasks involved exceeded the capacity of sheer human effort at an early stage. In the works, moreover, the

upsizing and integration of facilities for mass production in the 1960s and 70s was in sharp contrast to the remarkable proliferation and increasing sophistication of customer requirements to the kind of products and product quality thereafter. How to achieve efficiency in the production of this widely varied range of products using the means of mass production thus became a major issue.

The Japanese steel industry began aggressively introducing computer technology approximately 30 years ago, and together with the construction of business-related systems for head office and plant administrative functions, put great effort into the development of process control technology for the entire production process with the aim of achieving automation and precision control. Figure 20 shows annual trends in the number of process computers installed since 1975⁴⁾, investment in equipment, and the total labor force; the increase in installation and investment and the decrease in manpower present a clear contrast. Figure 21 shows the relative distribution of process computers by field of application, with about half of the total number used in the rolling division⁴⁾. The Japanese steel industry has continually played the undisputed role of leader in computer progress in both the range of applications and the technical level of systems, whether in the area of business or of manufacturing processes. It may be mentioned in this connection that the typical big steel company's computer system is of impressive proportions, comprising of sixty to one hundred thirty million steps.

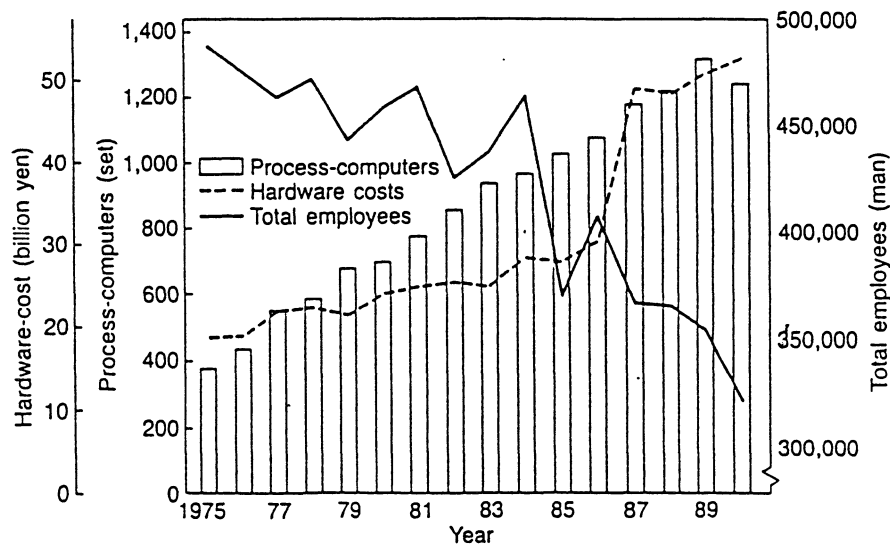

Fig.20 Changes in Number of Process-Computers and Total Employees in Japanese Steel Industry(1975-1990)

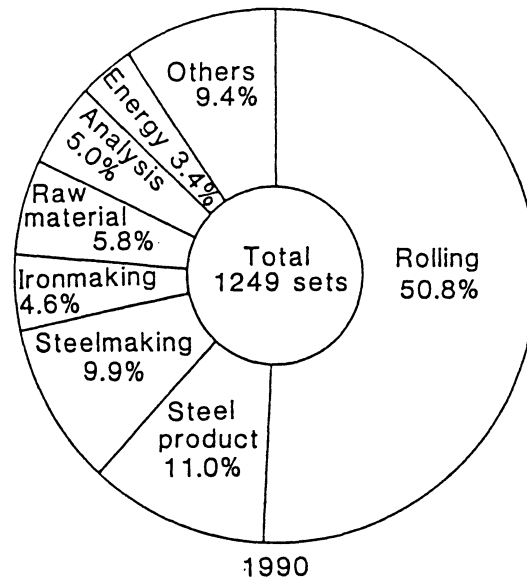

Fig. 21 Application of Process-computers by Sector in Japanese Steel Industry

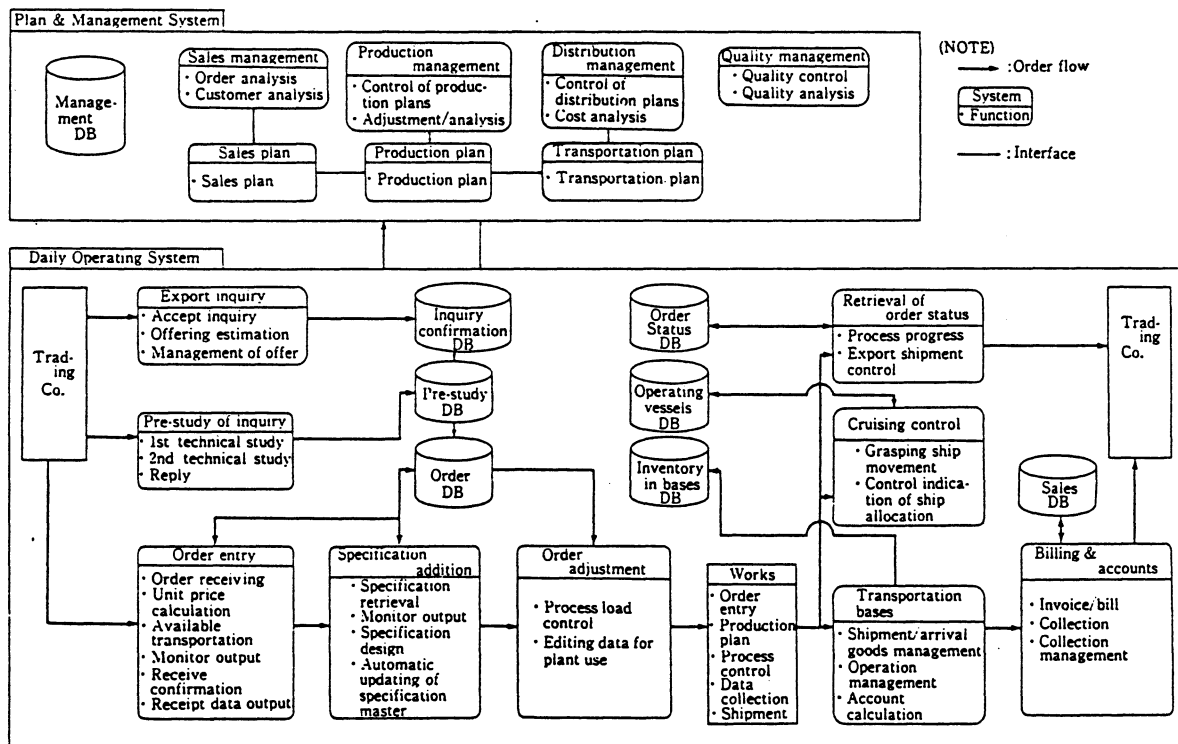

Fig.22 Configuration of the Business Computer System

More recently, the development of communication systems has been striking, and corresponding progress is being made in the efficiency of computer use. Beginning with customer orders, instructions to plants, production itself, and shipping are virtually all administered as a comprehensive activity by an online system which

takes full advantage of modern communication technologies such as telecommunications and optical highways, and great strides are being made in the realization of "paperless" operation. The basic configuration of the business computer system at Kawasaki Steel is shown in Figure 22²¹); the configuration of the production process computer system at Kawasaki's Mizushima Works is shown in Figure 23²²). Examples of systems by function are shown for various production processes in Table 4²²).

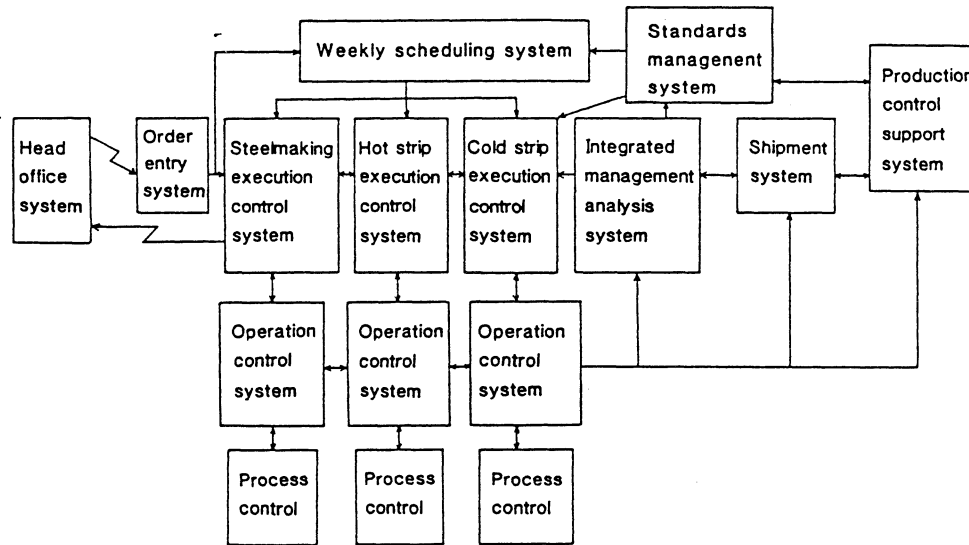

Fig 23 Configuration of the Steelmaking, Hot-rolling and Cold-rolling Systems at Mizushima Works

More sophisticated systems are also being developed using knowledge engineering, or artificial intelligence (AI), and the examples of application are increasing annually. Figure 24 shows the fields of application of AI systems in recent years, categorized by method²³). More reliable real-time control of processes is being achieved by the application of these high-level systems, which are playing an important role in the progress of automation and precision control, the transition to higher product quality levels, and energy and labor savings.

It is also becoming possible to meet the contradictory requirements of high-efficiency mass production and small-lot, multi-kind operation by use of flexible manufacturing systems (FMS).

Table 4 Summary of Process Control System Refurbishment at Mizushima Works

The problems presented by "number-crunching," or the increasing complexity of calculations in sophisticated systems of this type are being solved by the use of recently available super computers. Super computers are also finding use in calculations associated with complicated research and development tasks, image processing, and the construction of data-bases involving massive amounts of information.

As mentioned above, the role which computer technology is playing in the development of the contemporary steel industry is great, and nowhere is its use more indispensable than in Japan, where such great importance is placed on accuracy and detail.

Process	Functions
Hot metal	Torpedo car tracking Pretreatment control
Steelmaking	Calculation of sub-materials quantity New blowing control 2nd refining control
Continuous casting	Casting process control Cutting process control Machine diagnosis Conditioning line control
Hot strip mill line	Slab handling control in yard Reheating furnace control Sizing press control Mill-pacing Step-up control Cooling water control Coil handling control in yard Machine diagnosis
No. 1 cold tandem mill line	Mill-pacing Set-up control Flying thickness change control Flying width change control Tracking of welding points Coil dividing control
CAL	Sheet temperature control Preset for various operational conditions Tracking of welding points Coil dividing control Machine diagnosis
EGL	Plating amperage control Preset for various operational conditions Tracking of welding points Looper position control Coil dividing control Machine diagnosis Control for transfer equipments

Notation: ⊙: Newly developed
○: Improved

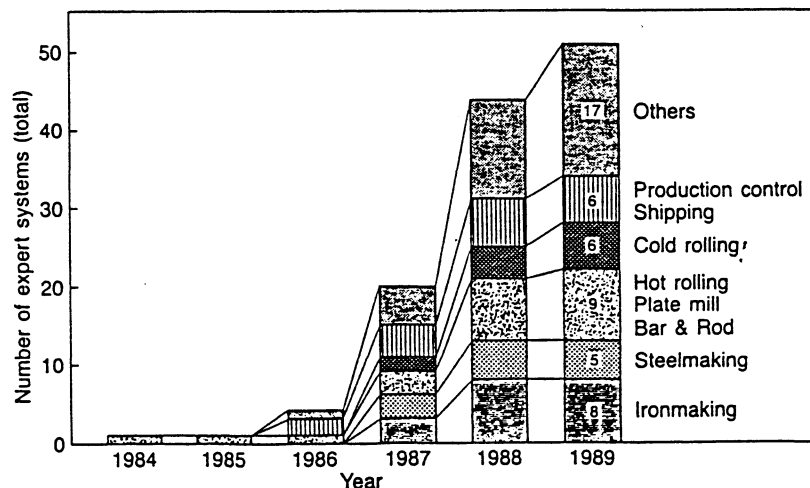

Fig 24 Progress of Expert Systems Applied to Japanese Steel Industry

V. Improvement of Product Quality

The development of steel sheet products in Japan is strongly related historically to developments in the auto industry. The postwar starting point for sheet technology was an antiquated production process which began with the open hearth furnace and ingot-cast rimmed or killed steels, and single sheet rolling using small pull-over mills, and ended with box-style batch annealing. The introduction of continuous rolling equipment began with hot strip mills in the 1950s. With the introduction of the basic oxygen furnace and continuous caster in the 1960s and 1970s, the last of the older facilities was eliminated and an entirely new production setup realized.

The 1980s, as previously mentioned, saw technical innovation in the upstream processes and continuation of downstream facilities, as well as the progressive application of a high level of computer control to the entire production process. The shape and dimensional features and internal and surface quality of sheet steels require comprehensive control of the entire manufacturing process, which exemplifies the current state of the art in steel manufacturing technology.

Deep drawing properties of steel sheets, which are a fundamental requirement for auto-use steels, are determined mainly by their crystallographic texture, which is controlled by chemical composition design, and rolling, annealing, and other process conditions. Effective decarburization is essential, particularly in the production of ultra-deep drawing steels. Past practices included open coiling of the cold rolled steel sheet and decarburization batch annealing in a hydrogen atmosphere. More recently, converter technology and the use of secondary refining techniques have made it possible to achieve carbon levels as low as 20-30 ppm on a regular basis, and premium grade steels are now produced on a mass production basis. The trend in the minimum carbon levels of commercial products over the last thirty years is shown in Figure 25⁵). Kawasaki Steel is currently shipping about 100,000 tons per month of ultra-low carbon interstitial-free steel (including coated

products produced from interstitial-free base materials). Ultra-low carbon steels are generally used in components which are difficult to form by pressing; two examples are shown in Figure 26²⁴).

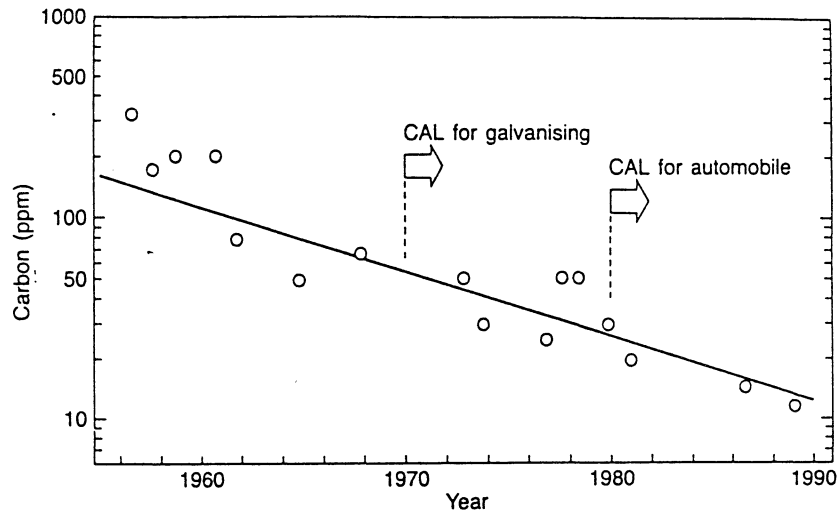

Fig.25 Decreasing Trend in Carbon Content of Steel Sheet (Kawasaki Steel)

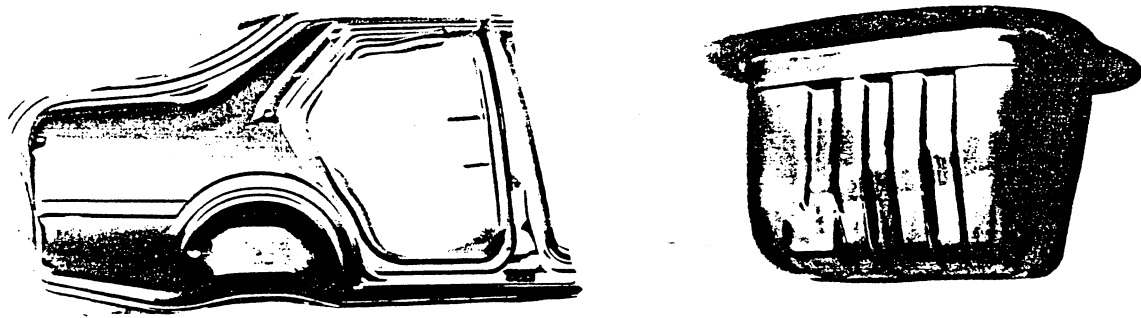
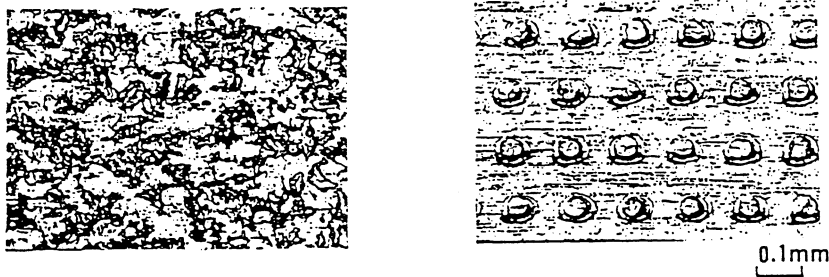

Fig.26 Examples of Deep-Drawn Automobile Parts

When steels are to be deep drawn, surface roughness control based on the expected relationship between the characteristics of the die and properties of the lubricant is extremely important. In skinpass rolling, which is the final process, the surface of the rolls was formerly roughened, or "dulled," by either shot blasting or electric arc discharge, and the required degree of roughness was thus imparted to the surface of the material. However, while it is possible to control average roughness with these methods, it is in principle difficult to control the detailed distribution of roughness characteristics, which determines the light reflectivity of the pressed panel. This is a

drawback, since poor reflectivity has an adverse on the luster of the painted auto body.

Laser technology provided the solution to this problem. A regular pattern of small concavities or dimples on the order of 100-200 μm in diameter can be formed by exposing the rotating skinpass rolls to a choked CO_2 laser beam while simultaneously blowing oxygen onto the area. Both the diameter and the pattern of the concavities can be controlled by this method. A flat area will remain between the concavities when deep drawing is conducted with appropriate lubrication, producing an ideal surface which retains its luster after painting. An enlarged photo of the surface of a steel sheet rolled with laser-dulled skinpass rolls is shown in Figure 27 in comparison with material processed by the conventional method²⁵). Material produced using this technique provides superlative top coat luster even when the undercoat is not hand polished, and has already won strong acceptance in the Japanese auto industry.



(a) Shot blasted

(b) Laser textured

Fig.27 Comparison of Steel Sheets Dulled by Conventional (a) and Advanced Technique (b), Kawasaki Steel LASER MIRROR

On the other hand, great attention has been given to the prevention of auto body rust, which has become a serious problem in the northern United States and Canada, where salt and CaCl_2 are used extensively to melt snow. Anti-corrosion goals have been established in both Canada and the United States, and makers now offer guarantees against cosmetic corrosion of the outer coat and perforation of the base sheet. To meet these requirements, there is an increasingly fast movement toward rust resistant coated steels for outer panels. Recent statistics indicate that coated steels account for

25-40% of steel sheet materials used in Japanese automobiles. The average is 30%, but this figure is expected to rise to 50%.

All plated and/or coated steels have a zinc plating base, but various types are used. In terms of production method, the two major categories are hot dip galvanizing and electrogalvanizing, although a vacuum evaporation coating method has also been developed. In the hot dip process, pure zinc is used, frequently at coating weights of 60-100 gr/m². In the galvannealing process the coating is a Zn-Fe alloy which is made by the diffusion of iron from the substrate steel sheet into the Zn layer by heat treatment after hot dip galvanizing. In this case, the coating weight is relatively light at 30-50 gr/m², because Zn-Fe alloy offers better corrosion resistance than pure Zn. To ensure the uniformity and quality of the phosphate film applied as a pretreatment for auto body painting, either a thin Fe-rich Fe-Zn (15%) film or a thin Fe film containing a small amount of P is applied to the surface of the Zn-Fe alloy, increasing the activity of the coated surface²⁶).

Some pure zinc electrogalvanizing is done in Japan, but the high cost of electricity makes platings of over 30 gr/m² economically impractical. Accordingly, products with thinner platings have been developed for commercial use. These include alloy coatings sufficient to guarantee corrosion resistance and composite coatings with organic top layers. Typical alloy platings are Zn-Ni (11-13%) and Zn-Fe (approximately 15%). As is the case with the hot dip products, composite-coated sheets with thin Fe-rich Fe-Zn (approximately 15%) or Fe-P layers applied over the Zn-Ni and Zn-Fe electroplated coatings are used in auto and other practical applications. Organic coated products are made by coating 20-30 gr/m² Zn-Ni steel sheets a unique organic film approximately 1 μm thick, which is baked on after plating²⁷).

Coated steel sheets must offer a uniform and attractive surface, and from the viewpoint of function, good rust resistance. However, they must also satisfy a wide and often contradictory range of other requirements: They should be resistant to small dents caused by local peeling of the coating during press forming; they should provide good phosphatability and hence good paint adhesion, and be resistant to

peeling after low temperature shock to the baked painted film ("stone chipping"); they should possess excellent spot weldability and not cause shortening of the service life of electrode tips. To satisfy all these requirements, a great deal of effort has been devoted over the last ten years not only to basic research, but also to research and development related to the specifications of actual equipment and operational techniques. These efforts are continuing, and it appears likely that further improvements can be achieved.

Automotive body steels, as can be seen from Figure 28²⁸⁾, have become progressively thinner over the last thirty years, which has been made possible by techniques for increasing tensile strength. Simply increasing the strength of the sheet, however, is not sufficient. Technical problems arise because it is also necessary to maintain ductility and drawability, prevent deterioration in spot weldability, and avoid cost increases. For these reasons, it is not acceptable merely to increase the carbon content or add alloying elements.

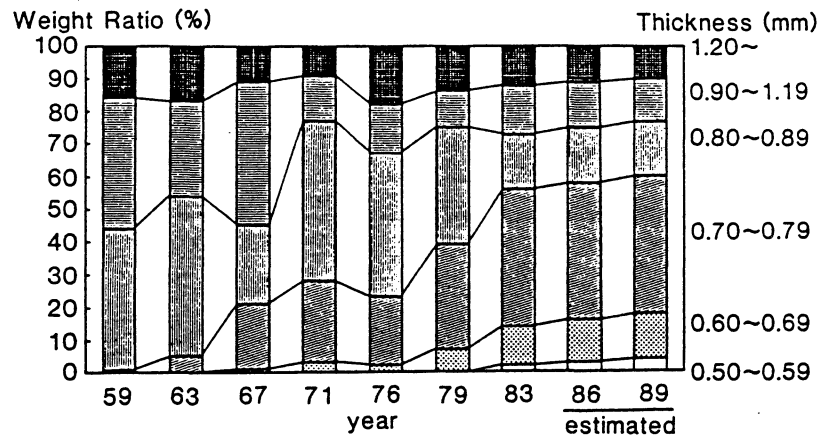

Fig.28 Yearly Trend of Sheet Thickness for Automobile Body Panels in Japan

We took the opposite starting point in solving the problem, and developed a high tensile-strength deep drawing steel of an entirely new type using ultra-low carbon steel as the base material. With a proper selection of rolling and annealing conditions, high tensile strength can be obtained by adding trace amounts of P and Ti or Nb to steel with a 20-40 ppm carbon content without deterioration of the microstructure required for deep drawing. Greater strength is produced by the solid solution hardening of P and the precipitation hardening of fine carbides of the Ti or Nb. Steels of this type in the

35-38 kg/mm² tensile strength class are commonly used in the current generation of Japanese automobiles, comprising about 30% of inner panels and 70-90% of outer panels²⁹).

Another notable product, bake-hardenable steel sheet (BH) was also developed using the ultra-low carbon material. Proper control of continuous annealing conditions makes it possible to retain the solid solution carbon in the final product, producing a material with a low yield point and good elongation, which is well suited for deep drawing. When the auto body paint film is baked at approximately 180°C, the solute carbon in the steel precipitates as fine carbides which improve tensile strength. Bake hardenable sheet is used in inner and outer panels of auto doors which are difficult to form³⁰).

The manufacture of automotive steels which will satisfy strict quality specifications requires a high level of technology from the steelmaking step through the final processes of annealing and skinpass rolling and careful attention to operational details. As an example of the specifications which users apply to surface defects, as much as ten tons of steel coil may be rejected for one or two minor flaws. Good internal and surface quality alone are not adequate to satisfy standards like these. It is also necessary to establish a dust-free environment for the downstream processes. Some processes, in spite of the enormous size of the equipment, are now conducted under semi-clean room conditions. A variety of handling and packaging methods has also been devised.

VI. Research and Development Activities

Following the Second World War, the Japanese steel industry introduced a number of technologies from Europe and the United States, but with Japan's economic development, the steel industry's research and development capabilities also expanded. The greatest reason for the rapid progress of the Japanese steel industry since the end of the war has been the industry's continuing attention to practical, plant-site innovation and a firm commitment to implement and improve the new technologies developed by its large body of

outstanding technical and research people. In Japanese industry, and this is not limited to the steel industry, high level technical people are assigned not only to the laboratory but also to plant sites, where they have a direct input into practical technical innovation on a regular basis. The results of this system can be seen in the high level at which equipment renovation and the improvement of operational techniques is conducted.

In the laboratory as well, activities are not limited to fundamental and theoretical research. Researchers remain close to activities in the field and have a working relationship with technical people in manufacturing plants. It is characteristic of Japanese industry that the development and improvement of technology are based on practical realities.

The Iron and Steel Institute of Japan has also played an vital role in the technical development of the Japanese steel industry. Under its auspices, academic and industry specialists have established technical committees in various fields beginning with ironmaking and steelmaking. By sponsoring meetings and plant tours, these groups have contributed to continuing innovation in technology and production efficiency through an exchange of information and the competition of new ideas. The exchange of knowledge and experience in research conferences and symposia held in addition to the regular spring and fall academic conferences has also provided useful stimulation.

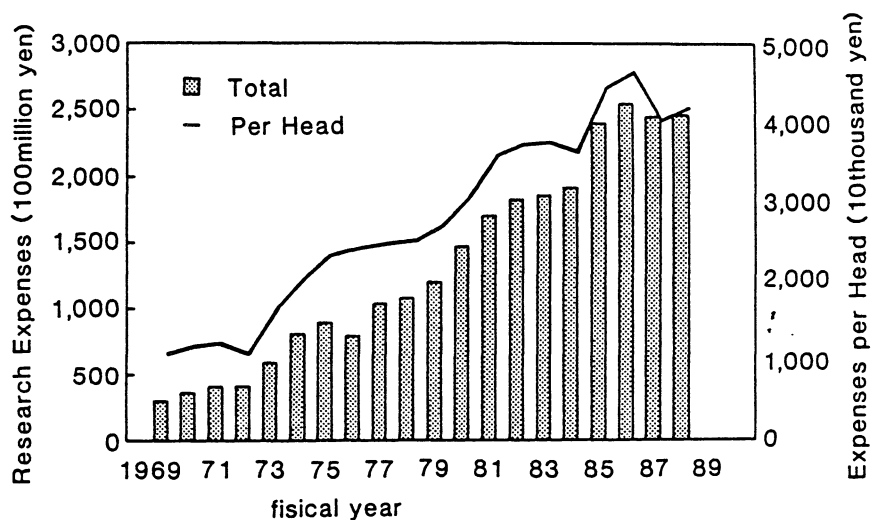

Fig.29 Progress of Total Research Expenditures in Japanese Steel Industry

The annual trend in the funding of research and development activities by the Japanese steel industry is shown in Figure 29³¹⁾. The Japanese steelmakers have begun to move into non-steel areas of business in recent years and are devoting a considerable amount of research and development funding to such efforts, but, as shown in Figure 30³¹⁾, both the number of researchers and research expenditures in steel-related areas have remained steady, and in some cases actually increased, in spite of the broad reduction in the total number of employees in recent years.

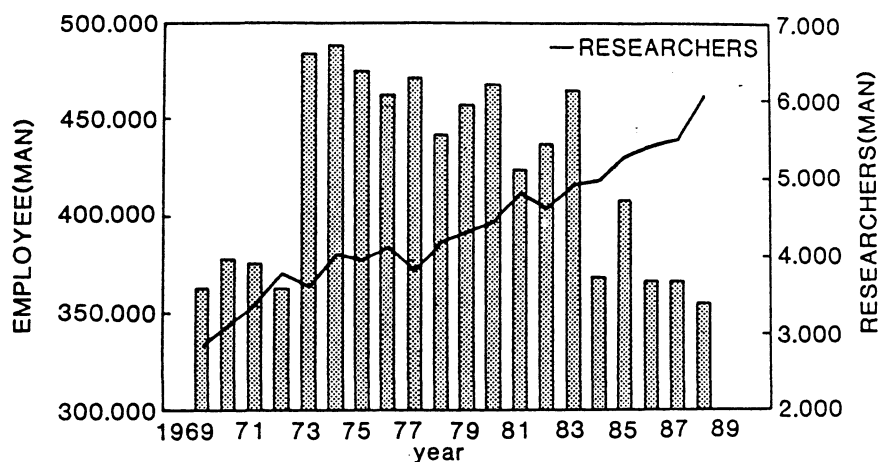

Fig.30 Changes in Number of Employees and Researchers in Japanese Steel Industry

The Japanese steel industry is also promoting research and development in connection with several major technologies, some of which are joint ventures among several steelmakers, with funding assistance from either the Japanese government or the Coal Research Centre. Although the steel industry is regarded in some quarters as being at the mature stage as far as technical development is concerned, many R. & D. tasks still remain in both equipments and operations.

VII. Future Tasks

The Japanese steel industry is faced with a number of necessary tasks, but among the most pressing are (1) the superannuation of virtually the entire stock of coke ovens, (2) "graying" of the workforce, (3) increasing pressure from the marketplace for "small-

lot, multi-kind" production, and (4) stricter environmental regulations.

Most of Japan's coke ovens were constructed in the 1960s. Until now, the development of maintenance technology has been adequate to keep these units functional, but assuming 35 years as the probable limit on oven life, the number of units in service will steadily decline over the next few years, as shown in Figure 31⁵⁾. Even assuming an average PCI (pulverized coal injection) level of 85 kg/ton of pig, the industry will face a coke shortage in 2004. Various alternatives are being developed, including more positive use of PCI, the formed coke process, and the direct smelting reduction of iron ore using coal. Major research and development projects are underway in each of these technologies, and in particular, the direct smelting reduction process is being developed under the auspices of the Japan Iron and Steel Federation with joint funding from eight steel companies and financial support from the Coal Research Centre. This is a five year project, with the scale of test units gradually being increased and commercialization as a next-generation steelmaking process planned³²⁾.

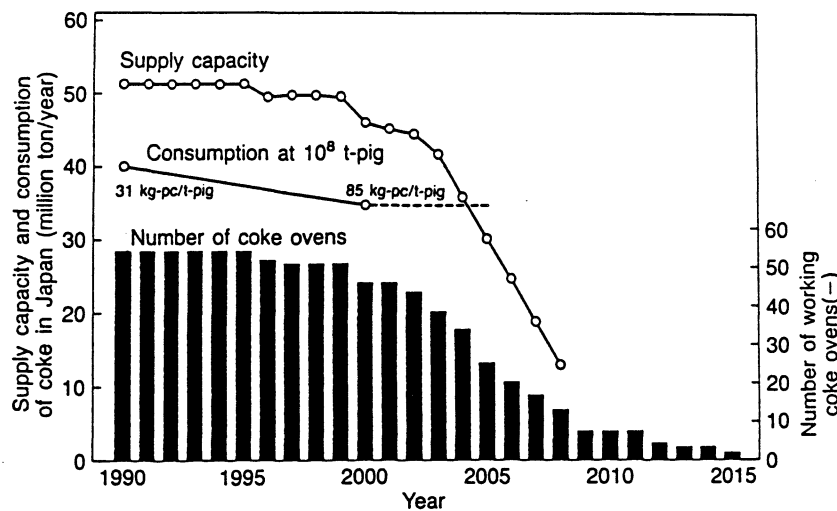

Fig.31 Forecast of Number of Working Coke Ovens and Coke Production Capacity in Japan

The average age of the employees of the major Japanese steelmakers is now 45, and even though younger people are being hired, long term plans to reduce the total number of employees will mean gradual graying of the workforce. From this viewpoint,

thoroughgoing rationalization and automation of facilities are necessary, with the ultimate aim of man-less operation. Some labor-intensive operations, such as furnace refractory repair and the maintenance and repair of rolling mills and other machinery would seem difficult to automate, but nevertheless, every effort must be made to mechanize these operations. A higher level of diagnostic technology should also be applied to prevent machinery problems and thus lighten the maintenance burden.

The automation of equipment and operations is essential to what are called Flexible Manufacturing Systems (FMS). Customer requirements are becoming increasingly diverse and sophisticated and can only be met by production in numerous small lots. A major challenge for the Japanese steel industry will be to answer these needs efficiently using what are essentially mass-production facilities. A restructuring of product lines, thorough review of production processes, and the development of new products and processes are required, with careful consideration of how all such factors can be incorporated into a flexible production system.

Finally, environmental problems are becoming a critical issue. The Japanese steel industry has faithfully observed what are considered the most stringent air and water pollution standards in the world and is continuing to strive for further improvements, but it is expected that environmental standards, including regulations governing CO₂ emissions, will become even stricter. Because a first requirement will be reduced emissions of harmful substances, additional research on separation techniques is needed.

VIII. Summary

Following the Second World War, the Japanese steel industry grew remarkably, leading the way for economic development in other sectors, until today Japan is the second leading steel producer in the world, behind only the Soviet Union in terms of crude steel output. A number of reasons have been offered for the striking development of the steel industry in an economy devastated by the Second World

IX. Acknowledgement

This paper was written and opened under the auspices of Japan Techno-Economics Society (JATES), and the author was greatly indebted to Mr. Shintaro Tabata, adviser, and Mr. Yoshio Ishikawa, executive director, of JATES for their very kind assistance.

The author wish to extend his hearty thanks to Mr. Kazuyoshi Konno and Mrs. Mayumi Kimura, Tech. Res. Div. of Kawasaki Steel Corp. (KSC), for their cooperation to arrange the information and data for this paper. Thanks are also given to Mr. Richard Hart head office of KSC, for his excellent advice in translating the manuscript to English, and to Mrs. Miyuki Arai, Tech. Res. Div. of KSC, for her work to prepare the draft.

The author is also grateful to Mr. Yasuhiro Yagi, chairman, and Mr. Shinobu Tosaki, president of KSC for their financial support and permission to publish this paper.

- 17) H. Miyake, Y. Yarita: Kawasaki Steel Giho, Vol.16, 1984, No.4, p.235, in Japanese
- 18) Private communication
- 19) Tekko-shinbun, OCT 15 / 1990, in Japanese
- 20) A. M. Karson Jr: Proc. of GALVATEC'89, Tokyo, ISIJ, p.276
- 21) N. Fujikawa, M. Tsuchida, Y. Michino: Kawasaki Steel Technical Report, No.20, 1989, p.5
- 22) W. Sakamoto, E. Tonooka, O. Hoshika: ibid. p.17
- 23) Data from the Ministry of International Trade and Industry, Japan
- 24) S. Satoh, M. Nishida: Kawasaki Steel Giho, Vol.16, 1984, No.4, p.273, in Japanese
- 25) K. Tsunoyama, M. Imanaka: Kawasaki Steel Giho, Vol.20, 1988, No.3, 204, in Japanese
- 26) K. Yamato, T. Ichida, T. Irie: Kawasaki Steel Giho, Vol.21, 1989, No.3, p.216, in Japanese
- 27) H. Ogishi, A. Yasuda: CAMP-ISIJ, Vol.3, 1989, S463, in Japanese
- 28) Data from a major Auto-Maker in Japan
- 29) Comment by major Auto-Makers in Japan
- 30) M. Kurosawa, S. Satoh, T. Kohara: Kawasaki Steel Giho, Vol.19, 1987, No.2, p.119, in Japanese
- 31) Report on the Survey of Research and Development; Statistics Bureau, Management and Coordination Agency, Japan, 1969-1989, in Japanese
- 32) Y. Tanaka, T. Miyazaki: CAMP-ISIJ, Vol.3, 1990, S1069, in Japanese

References

- 1) Tekko-nenkann, Tekko-shinbunsha, 1989, Appendix, in Japanese
- 2) Kaigaitekko-toukei, No.55, 1986, Japan Iron and Steel Federation (JISF), in Japanese
- 3) Tekkotoukei-yoran, JISF, 1970-1990, in Japanese
- 4) Tekkotoukei-yoran, JISF, 1990, in Japanese
- 5) Y. Yagi: Proceedings of The 6th I.I.S.C, 1990, Iron & Steel Inst. Japan (ISIJ)
- 6) American Metal Market, June 26 -/ 1990
- 7) Tekkotoukei-geppo, The Ministry of International Trade and Industry, Japan, April/1990, in Japanese
- 8) M. Hanmei: The 100th Nishiyama-kinengijutsukouza, ISIJ, Nov./1984, p.203, in Japanese
- 9) T. Imai: The 135th Nishiyama-Kinengijutsukouza, ISIJ, Nov./1990, p.86, in Japanese
- 10) Tekko-shinbun, Aug.18/1990, in Japanese
- 11) T. Nozaki, Y. Habu: Kawasaki Steel Giho, Vol.17, 1985, No.3, p.23, in Japanese
- 12) H. Sekiguchi: CAMP-ISIJ, Vol.13, 1990, p.1213, in Japanese
- 13) Data of Technical & Management Division in JISF
- 14) M. Okimori, E. Ikezaki: Seitetsu-Kenkyu, No.334, 1989, p.1, in Japanese
- 15) T. Hira, K. Isobe, H. Abe: Kawasaki Steel Giho, Vol.21, 1989, No 3, p.188, in Japanese
- 16) H. Nishi: The 92th Nishiyama-kinengijutsukouza, ISIJ, Sep./1983, p.117, in Japanese