

Temperature rise measurement for power-loss comparison of an aluminum electrolytic capacitor between sinusoidal and square-wave current injections

著者	Hasegawa K., Kozuma K., Tsuzaki K., Omura I., Nishizawa S.
journal or publication title	Microelectronics reliability
volume	64
page range	98-100
year	2016-09-18
URL	http://hdl.handle.net/10228/00006910

doi: info:doi/10.1016/j.microrel.2016.07.049

Temperature rise measurement for power-loss comparison of an aluminium electrolytic capacitor between sinusoidal and square current injections

K. Hasegawa^{a,*}, K. Kozuma^a, K. Tsuzaki^a, I. Omura^b, S. Nishizawa^{a,c}

^a *Department of Biological Functions Engineering, Kyushu Institute of Technology,
2-4, Hibikino, Wakamatsu-ku, Kitakyushu, Fukuoka, 808-0196, Japan*

^b *Department of Electrical Engineering and Electronics, Kyushu Institute of Technology,
1-1, Sensuicho, Tobata-ku, Kitakyushu, Fukuoka, 804-8550, Japan*

^c *National Institute of Advanced Industrial Science and Technology,
1-1-1, Umezono, Tsukuba, Ibaraki 305-8568, Japan*

Abstract

DC-link capacitors are a major factor of degrading reliability of power electric converters because they usually have a shorter lifetime and higher failure rate than those of semiconductor devices or magnetic devices. Characteristics of the capacitors are usually evaluated by a single sinusoidal current waveform. However, actual current flowing out of the converter into the capacitor is a modulated square current waveform. This paper provides experimental comparison of the power loss dissipated in an aluminium electrolytic capacitor between square- and sinusoidal-current injections. Power loss is estimated by temperature rise of the capacitor. Experimental results confirms that power losses of the square-current injection were always lower than those of the sinusoidal-current injection by 10-20%. Moreover, the power losses of the square-current injection can be estimated by a synthesis of fundamental and harmonic currents based on the Fourier series expansion, which brings a high accuracy less than 1% when more than fifth harmonic current is introduced. This comparison will be useful for estimating power loss and life time of electrolytic capacitors.

* Corresponding author.

E-mail address: hasegawa@life.kyutech.ac.jp (K. Hasegawa).

Temperature rise measurement for power-loss comparison of an aluminium electrolytic capacitor between sinusoidal and square current injections

K. Hasegawa^{a,*}, K. Kozuma^a, K. Tsuzaki^a, I. Omura^b, S. Nishizawa^{a,c}

1. Introduction

DC-link capacitors are a major factor of degrading reliability of power electric converters because they usually have a shorter lifetime and higher failure rate than those of semiconductor devices or magnetic devices [1]. Many researchers have been addressed reliability-related issues for the capacitors such as monitoring methods of capacitance and equivalent-series resistance (ESR) [2, 3], power-loss estimation [4, 5], and ageing law [6-8]. In general, ageing law of the capacitors strongly depend upon their operating temperature, which is known as an Arrhenius equation. Hence, accurate estimation of a power loss or temperature rise in operation is essential for the capacitors.

Characteristics of the capacitors are usually evaluated by a single sinusoidal current with a frequency like 120 Hz or 1 kHz [9]. However, actual ripple current flowing out of the converter into the capacitor is a modulated square-wave one [10]. In addition, the dc bias voltage across the capacitors also affects their characteristics such as power loss and ageing [1, 6, 8].

This paper presents experimental evaluation of power loss in an aluminium electrolytic capacitor into which a square current is injected, with comparing that a sinusoidal current is injected. The power loss is estimated by temperature-rise measurement instead of an electrical measurement.

2. Ripple current of dc-link capacitors

Power electronic converters produce a non-sinusoidal current waveform into the dc-link capacitor because a switching device chops the ripple current flowing into the dc-link capacitor. Thus, the current waveform looks a square one. As for the inverter, it

produces modulated square waveform because it usually applies a modulation technique to the output voltage or current such as the so-called pulse-width modulation (PWM). Although the so-called fast Fourier transform (FFT) can extract the multiple frequency components from the actual current, a power loss of the capacitor cannot be estimated using the multiple frequency components because power loss in general has a nonlinear characteristic. Thus, it is important to test the capacitors by the actual current waveform.

3. Temperature rise measurement for power-loss estimation

3.1. Experimental system configuration

Fig. 1 shows experimental system configuration for temperature rise measurement of an aluminium electrolytic capacitor. This paper employed an aluminium electrolytic capacitor of “EEUF1J221X” (FC-series, Panasonic), the rated working voltage of which is 63 V, and the nominal capacitance of which is 220 μ F. A bipolar power supply (BP4610, NF corp.) was used for injecting a sinusoidal or square current into the capacitor as well as providing a dc bias voltage.

Fig. 2 is a photo of the capacitor under test, where a thermocouple was put on the surface of the capacitor for the temperature rise measurement. Note that the temperature measured by the thermocouple was picked up after the temperature rising was sufficiently saturated.

3.2 Experimental Condition for sinusoidal and square waveform injections

This paper introduces the following two conditions

* Corresponding author.
E-mail address: hasegawa@life.kyutech.ac.jp (K. Hasegawa).

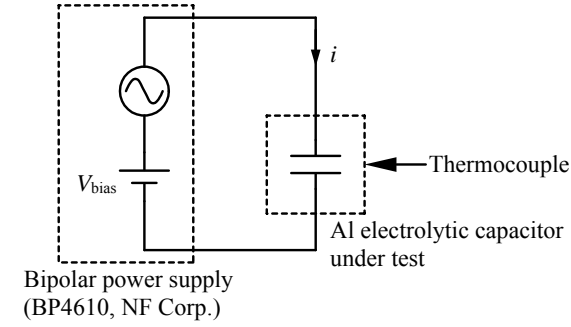

Fig. 1 Experimental setup.

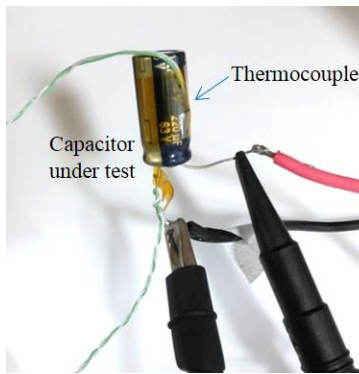

Fig. 2 Capacitor under test equipped with a thermocouple

for the ripple current.

- A) Root-mean-square value is fixed. (RMS-fixed condition)
- B) Fundamental-frequency amplitude is fixed. (FFA-fixed condition)

The former compares temperature rise between square- and sinusoidal-current injections, where the fundamental frequency was adjusted to be 120, 330, or 1000 Hz, and RMS value was adjusted to be 1.4 A. The latter measures temperature rise with injecting harmonic currents in order to approximate to a square waveform as follows:

$$i_{2n-1} = \sum_{k=1}^n \frac{1}{2k-1} A_1 \sin(2k-1)\omega t \quad (1)$$

where ω is the fundamental angular frequency, A_1 is the fundamental-frequency amplitude that is adjusted to be 1.8 A. The equation is based on a Fourier series expansion of the square waveform. This will indicate how much frequency range is necessary to power-loss estimation of the capacitor into which the square current is injected.

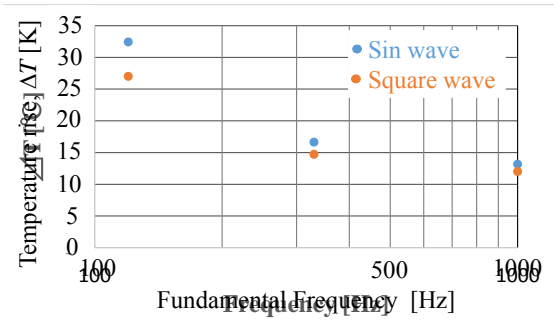

Fig. 3 Experimental results in RMS-fixed condition.

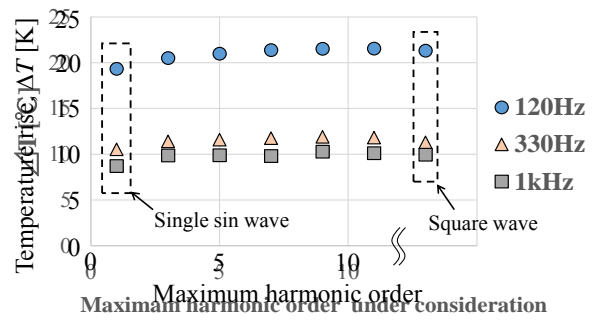

Fig. 4 Experimental results in FFA-fixed condition.

4. Experimental Results

4.1 Comparison between sinusoidal and square waveform injections

Fig. 2 shows experimental results in the RMS-fixed condition, where the ambient temperature was between 17 and 20 degrees Celsius, and the dc-bias voltage V_{bias} was 40 V. Temperature rises of the square-current injection is lower than those of the sinusoidal-current injection in all the fundamental frequencies. The reason why the temperature rise depended on the fundamental frequency regardless of waveform is that equivalent-series resistance (ESR) of electrolytic capacitors decreases as the fundamental frequency increases in general [8]. The next subsection provides measurement results of the ESR.

Fig. 3 illustrates experimental results in the FFA-fixed condition, in which the ambient temperature was between 18 and 20 degrees Celsius, and the dc-bias voltage was 40 V. This paper introduced the maximum harmonic order up to 11. Temperature rises in the condition approached to that of square-current injection as the maximum harmonic order increased, which can estimate the temperature rise of the square

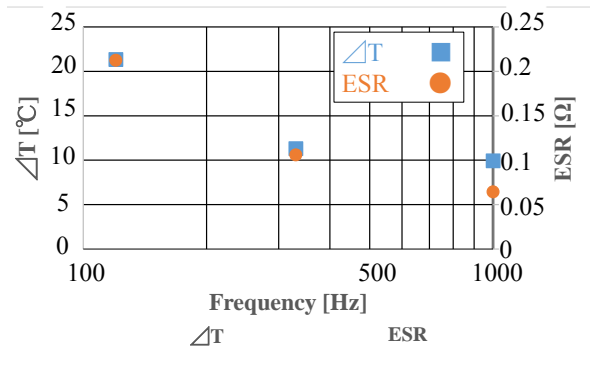

current by 1% difference when more than fifth harmonic current is introduced.

4.2 Relation between RMS and temperature rise

This paper measured the ESR of the capacitor under test using an LCR meter (ZM2371 NF corp.). The temperature of the capacitor in this ESR measurement was adjusted by a thermostat chamber to be the same as that in the temperature measurement of the square current injection. Fig. 5 shows relation between the ESR measurement results and temperature rise ones, which indicates that the relation was almost a linear function.

4.3 DC-bias voltage dependence of the temperature rise in the square current injection

Fig. 6 shows the relation between the dc-bias voltage and temperature rise in the square current injection. The lowest dc-bias voltage was adjusted to be 14 V in order not to make the capacitor voltage lower than 0 V including a ac voltage applied by the power supply. The temperature rise was a monotonically increasing function for each frequency. Increase rates of the temperature rises of 120, 330, and 1000 Hz were 5.3%, 0.9%, and 2.1%, respectively. Thus, the dc-bias voltage also has an influence on the power loss of the capacitor, but brings a somewhat smaller change than difference between the square and sinusoidal current injections.

5. Conclusion

This paper has provided experimental comparison of the power loss generated by an aluminium electrolytic capacitor between square- and sinusoidal-current injections. Power loss was estimated by temperature rise of the capacitor. Power

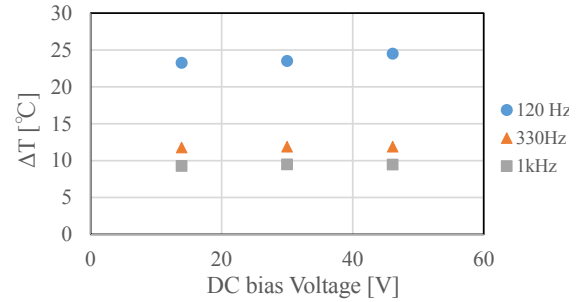

Fig. 6 Relation between the dc-bias voltage and temperature rise in the square current injection.

losses of the square-current injection were lower than those of the sinusoidal current waveform injection by 10-20%. In addition, the power losses of the square-current injection can be estimated by a synthesis of fundamental and harmonic currents.

References

- [1] H. Wang and F. Blaabjerg, "Reliability of capacitors for dc-link applications in power electronic converters—an overview," *IEEE Trans. Ind. Appl.* vol. 50, no. 5, pp. 3569-3578, 2014.
- [2] K. Harada, A. Katsuki, and M. Fujiwara, "Use of ESR for deterioration diagnosis of electrolytic capacitor," *IEEE Trans. Power Electron.*, vol. 8, no. 4, pp. 355-361, Oct. 1993.
- [3] K. Abdennadher, P. Venet, G. Rojat, J. M. Retif, and C. Rosset, "A Real-Time Predictive-Maintenance System of Aluminum Electrolytic Capacitors Used in Uninterrupted Power Supplies," *IEEE Trans. Ind. Appl.* vol. 46, no. 4, pp. 1644-1652, Jul./Aug., 2010.
- [4] J. M. Miller, C. W. Ayers, L. E. Seiber, and D. B. Smith, "Calorimeter evaluation of inverter grade metallized film capacitor ESR," in *Proc. of IEEE ECCE*, pp. 2157-2163, 2012.
- [5] A. Braham, A. Lahyani, P. Venet, and N. Rejeb, "Recent Developments in Fault Detection and Power Loss Estimation of Electrolytic Capacitors," *IEEE Trans. Power Electron.*, vol. 25, no. 1, pp. 33-43, Jan. 2010.
- [6] M. Makdessi, A. Sari, and P. Venet, "Metallized polymer film capacitors ageing law based on capacitance degradation," *Microelectron. Rel.*, vol. 54, pp. 1823-1827, 2014.
- [7] H. Wang, D. A. Nielsen, and F. Blaabjerg, "Degradation testing and failure analysis of DC film capacitors under high humidity conditions," *Microelectron. Rel.*, vol. 55, no. 9-10, pp. 2007-2011, 2015.
- [8] M. Makdessi, A. Sari, P. Venet, G. Aubard, F. Chevailier, R. Preseau, T. Doytchinov and J. Duwattez, "Lifetime estimation of high-temperature high-voltage polymer film capacitor based on capacitance loss," *Microelectron. Rel.*, vol. 55, no. 9-10, pp. 2012-2016, 2016.

2015.

- [9] NICHICON CORPORATION. "General Description of Aluminum Electrolytic Capacitors," [Online]. available:
<http://www.nichicon.co.jp/english/products/pdf/aluminum.pdf>
- [10] K. Hasegawa, I. Omura, and S. Nishizawa, "Design and Analysis of a New Evaluation Circuit for Capacitors Used in a High-Power Three-Phase Inverter," IEEE Trans. Ind. Electron., vol. 63, no. 5, pp. 2679-2687, May 2016.