

X Всеукраїнська студентська науково - технічна конференція
"ПРИРОДНИЧІ ТА ГУМАНІТАРНІ НАУКИ. АКТУАЛЬНІ ПИТАННЯ"

Секція:

Електротехніка, електроніка та світлотехніка

УДК 681.5

Andy Amexo – student of group IEE-42

Idem Daniel Richards – student of group IEE-42

Ternopil Ivan Puluj National Technical University

SMART SYSTEM FOR LAPTOP COOLING

Supervisor: Andriy Palamar

Keywords: microcontroller, Arduino

Smart systems are intelligent devices that enable the collection of high-quality data through embedded sensors that communicate over wired or wireless networks. The supply and demand for utilities such as gas electricity and water are continually monitored by instrumented devices such as smart meters, and this might actuate strategies devised by intelligent components. Interconnection creates linkages of data among systems and people. High degrees of interconnectivity enable smart systems to become reality. The linkage and integration among people, objects, and systems are enabling new ways to gather, share, and act on information. Intelligence in the form of new computing models, algorithms, and advanced analytics will enable better decisions and outcomes for business, government, non-profits, and individual users, as well as reactions of complex systems to emergent demands.

The brain behind these intelligent devices are microcontrollers. These little chips with the integration of other peripheral devices such as ram serial ports and others analyse input data and decide on which action will be most suitable in a given situation to some extent.

The actuality of this project is to ensure that damages to sensitive parts of a laptop are prevented and to preserve the efficiency of the laptop by automatically cooling the laptop when it reaches it's thresh hold temperature. So it was decided to create a prototype basic smart system that cools down overheating laptops.

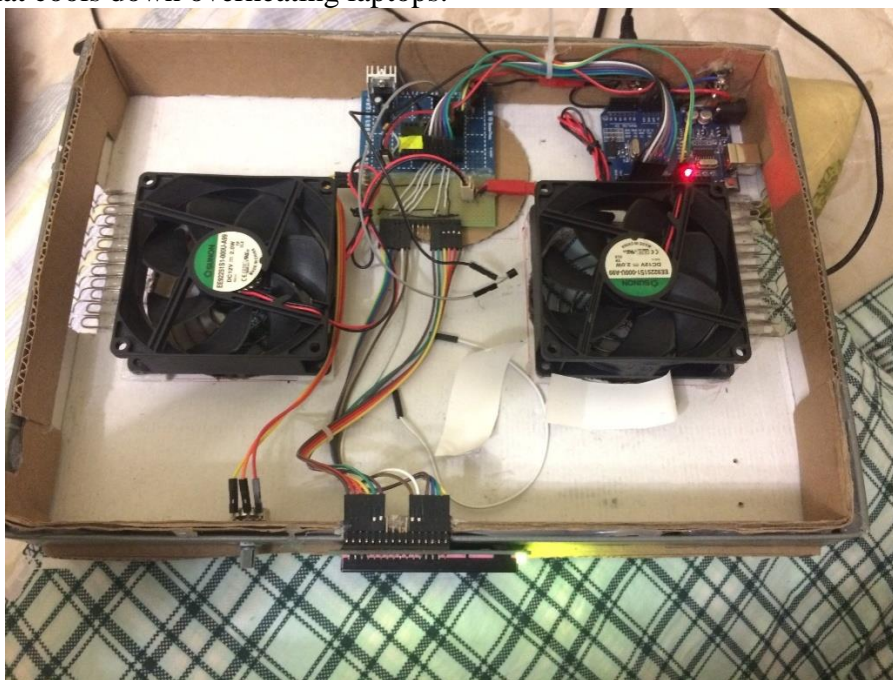

Fig.1 prototype of laptop cooling system

The aim of this project is to liberate an individual from experiencing error complications pertaining to heat while using his or her laptop.

The prototype is a 34x24.5x4 cm measured as length width and height respectively. The main devices embedded in this prototype are an Arduino microcontroller, two 2 watt fans running at a 12 v DC with a rotation speed of 3000 rpm, a 16x2 LCD display and a circuit board with basic elements such as resistors, capacitors, transistors and others.

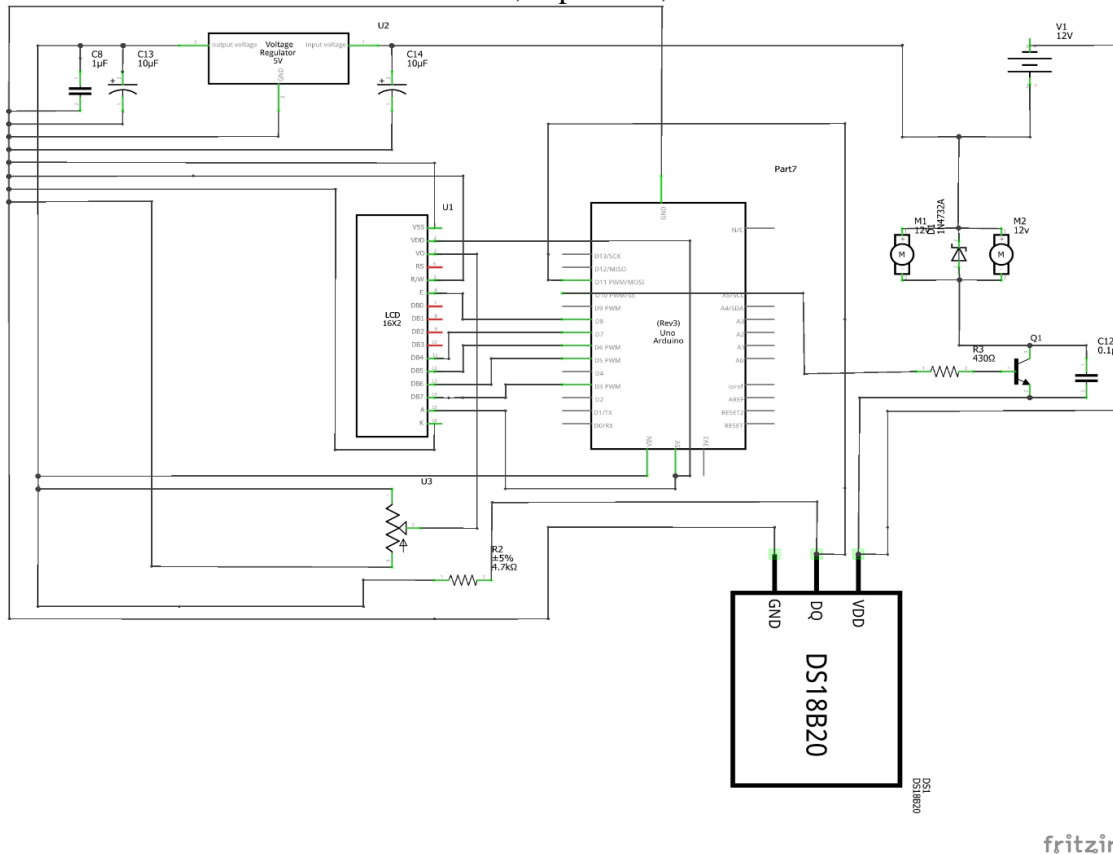

Fig. 2 Electric circuit scheme of the prototype

The schematic above shows how the electrical part of the prototype was designed. 12 volt 1 amp adapter was used to power the entire system. Current at 12volts is first transferred to the thermal fans through a 430-ohm resistor and a transistor before it's connected to a digital pin. Then, a LM317 voltage regulator steps down the voltage from 12 to 5v this is then used to supply current to the Arduino microcontroller and the LCD display through a potentiometer.

Arduino microcontroller is fed with programmable instructions in sets of code using the Arduino IDE and C++ programming language. The temperature sensor DS18B20 collects temperature data from the heat vents of the laptop and then it's sent to the microprocessor for analysis every 50 milliseconds. The thresh hold temperature to trip the fans is 40°C so at any moment the temperature sensor detects this condition, the fans begin to rotate at maximum speed this occurs for until the temperature in the laptop decreases to 20°C then the fans shut down and the process starts again.

An electrical scheme for the project was developed by a fritzing software

Program for the project was written using C++ on Arduino IDE

This is a basic description of how our smart system works although more features are yet to be added such as speed variation of the fans and an interrupt in the system for manual use. What we have displayed in this thesis is one of the few upcoming smart system prototypes by many electronic hobbyists. This shows enough proof that the in the next 20 to 30 years about 70 to 80 % of the world's population will be integrated with smart systems.