

Monitoring Muscle Stem Cell Cultures with Impedance Spectroscopy

Yaiza Yuste², Juan A. Serrano¹, Alberto Olmo¹, Andrés Maldonado-Jacobi¹, Pablo Pérez¹,
Gloria Huertas¹, Sheila Pereira², Fernando de la Portilla² and Alberto Yúfera¹

¹*Instituto de Microelectrónica de Sevilla (IMSE), Universidad de Sevilla, Av Americo Vespuccio, S/N, Sevilla, Spain*

²*Instituto de Biomedicina de Sevilla (IBIS), Campus Hospital Universitario Virgen del Rocío, Sevilla, Spain*

Keywords: Impedance Spectroscopy, Oscillation-Based Test (OBT), Skeletal Muscle, Myoblast, Stem Cell Differentiation.

Abstract: The aim of this work is to present a new circuit for the real-time monitoring the processes of cellular growth and differentiation of skeletal myoblast cell cultures. An impedance spectroscopy Oscillation-Based technique is proposed for the test circuit, converting the biological system into a voltage oscillator, and avoiding the use of very high performance circuitry or equipment. This technique proved to be successful in the monitoring of cell cultures growth levels and could be useful for determining the degree of differentiation achieved, of practical implications in tissue engineering.

1 INTRODUCTION

Impedance spectroscopy is currently used for real time monitoring of different biological processes, such as cell toxicity, cell invasion or inflammation (Giaever and Keese, 1984; Daza et al., 2013; Pérez et al., 2017). Impedance spectroscopy has the advantage of being a non-invasive technique (current intensity can be kept at minimum levels) and is relatively non-expensive (only one sample or petri plate is required for a performance curve).

Different circuits have been used for these applications, using different topologies and electrodes depending on the application.

The use of impedance spectroscopy in the monitoring of the growth and differentiation of stem cells is recently being studied for different tissue engineering applications. Human mesenchymal stem cells (hMSCs) development has been studied with impedance spectroscopy in different works (Eun et al., 2011; Hildebrandt et al., 2010). The impedance spectra of osteogenic treated hMSCs reported a significant increase of the magnitude of impedance compared to controls cultivated in normal growth medium (Hildebrandt et al., 2010). In this work, it is concluded that impedance spectroscopy is an appropriate method for non-invasive characterization of osteogenic differentiation of hMSCs, which is relevant for quality control of cell-

based implants and cell-based test systems for drug development (Hildebrandt et al., 2010).

Other interesting and recently used stem cell lines in tissue engineering are adipose stem cells (Nordberg et al., 2017) or myoblasts (Liao and Zhou, 2009). Skeletal muscle tissue engineering holds great promise for regenerative medicine. However, ex vivo cultivation methods typically result in a low differentiation efficiency of stem cells as well as graft that resemble the native tissues morphologically, but lack contractile function.

In this work, a new circuit is proposed to apply the impedance spectroscopy technique in myoblast assays, to see whether this technique is useful in the study of growth and differentiation of these cells into muscular structures, in a similar way as it was studied for others (Hildebrandt et al., 2010). The circuit is based on the Oscillation-Based Test technique, with amplitude and frequency values obtained dependant on the cell culture bioimpedance.

In section 2, the description of this circuit is presented, together with the description of the initial experiments performed.

2 MATERIALS AND METHODS

2.1 Impedance Spectroscopy Monitoring System

For cell culture assays, commercial electrodes 8W10E PET, from Applied Biophysics (Applied Biophysics) were employed. The multi-well is composed of eight separated wells; each one contains ten circular biocompatible gold microelectrodes of 250 μm diameter in parallel, and a surrounding reference electrode.

The proposed circuit for bioimpedance measurements is based on the well-known technique of Oscillation-Based Test (Huertas et al., 2015). It avoids the use of very high performance circuitry or equipment, as well as accurate current/voltage generators, Instrumentation Amplifiers (IA) and exact precise demodulation circuits, converting the bioimpedance in a voltage oscillator, whose oscillation parameters (f_{osc} , a_{osc}) are dependent of the biological sample under test. This circuit performance is fully described in (Huertas et al., 2015; Pérez et al., 2017). Simplified circuit diagram is illustrated in Fig. 1C. Cell cultures are incorporated to circuit analysis through the electrode-cell impedance value $Z_{cell-electrode}$. This circuit works as a voltage oscillator, being characterized by its oscillation parameters: frequency of oscillation (f_{osc}) and amplitude of oscillation (a_{osc}) at the output voltage signal (V_{out}). The aim, in this application, is to characterize cell growth and differentiation level through these parameters. For the proposed circuit, has been observed that the amplitude of oscillation is more sensible to changes in bioimpedance (Huertas et al., 2015). A limited maximum current intensity of 10 μA was applied to the cell cultures.

2.2 Cell Cultivation and Experiments Performed

Rat skeletal myoblasts were obtained from *Rattus Norvegicus* L6 cell line (ATCC® CRL-1458™) and were cultured at 37°C in a CO₂ incubator at 5% on the Instituto de Biomedicina de Sevilla (IBIS). The growth medium used was Minimum Essential Medium α (12571-063, Gibco) supplemented with 10% fetal bovine serum (F7524, Sigma) and 1% penicillin-streptomycin (15140-122, Gibco).

After the cells reached 85-90% of confluence, they were sub-cultured using trypsin-EDTA at 0.05% (25300-062, Gibco) and seeded 10^4 cells in the appropriate wells of the multi-well used (wells 2,

3, 4, 6, 7, 8) with growth medium. When the specific wells reached 70% of confluence, after rinse with phosphate buffered saline (L0615, Linus), the medium was changed to differentiation medium, MEM α supplemented with 2% horse serum (S0910, Biowest) and 17.8mM NaHCO₃ (S6297, Sigma-Aldrich). Microscope images were taken with the Olympus IX-71 inverted phase microscope.

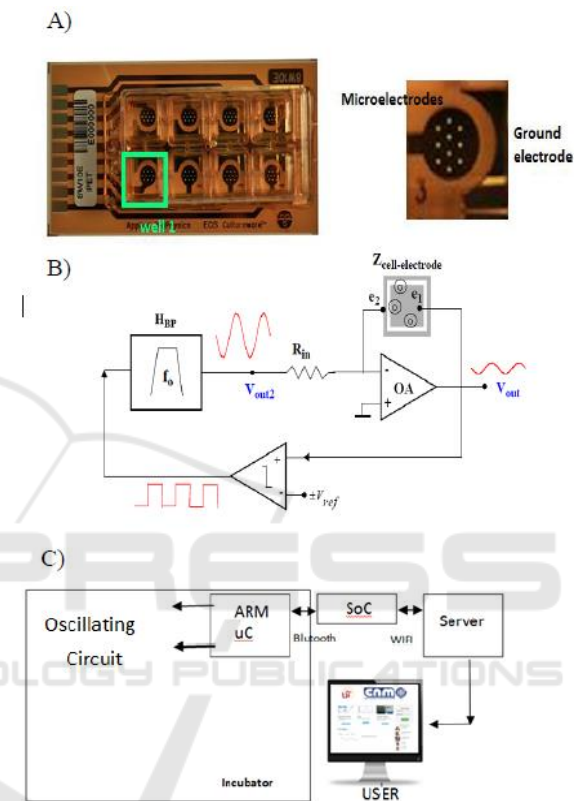

Figure 1: Impedance Spectroscopy monitoring system. A) 8W10E PET cultureware from Applied Biophysics (Pérez et al., 2016) with 8 wells of 0.8 cm². Detail of each well: cells are measured on top of the 10 circular gold electrodes in parallel, with 250 μm diameter. The ground electrode can be seen on the right. B) Simplified block diagram proposed for measurements, composed by a bioimpedance converter, comparator and bandpass filter. Oscillation parameters: amplitude (a_{osc}) and frequency (f_{osc}) can be measured over the signal V_{out} . C) Communication circuit used.

All cell cultures (wells 2, 3, 4, 6, 7, 8) were held in growth medium for control the first days, starting from 10.000 cells. The differentiation in myotubes (wells 6, 7, 8) was initialized by treatment with differentiation medium, whereas the rest were held in growth medium for control (wells 2, 3, 4). Cell culture growth medium and differentiation medium were measured by the impedance system (wells 1,

5), in order to differentiate any possible effect of the medium used. The medium was replaced every 2–3 days. Of the two group of cells, one well was left without measuring impedance (wells 4, 8), as a control, in order to detect any possible effect of current intensity on stem cells. Table 1 summarizes the wells used in the 8W10E PET cultureware.

Temperature and humidity values were also monitored during all the experiment. In each medium change, cells were seen under the microscope, and photographs of all wells were taken. Two experiments were performed, in order to compare results.

3 RESULTS AND DISCUSSION

Similar results were obtained in both experiments. Fig. 2 shows the signal registered for the different cell cultures, corresponding to the amplitude of the oscillations of the circuit (a_{osc}), together with the measurement of the temperature and humidity values. The OBT circuit used successfully detected the initial cell growth, in a similar way as in other cell types (Daza et al., 2013; Pérez et al., 2017). The amplitudes observed are useful parameters to determine the confluence level of the cell culture or fill factor (defined as the area occupied by cultured cells divided by the total culture area). A practical threshold could be set at a fill factor of 70%, as cells should change to differentiation medium at this moment. In Fig. 2 it can be seen the behaviour of muscular stem cells without differentiation (wells 2, 3), following a similar behaviour to other cell cultures (Eun et al., 2011; Hildebrandt et al., 2010), in comparison with muscular stem cells that have followed a differentiation process (well 7). Stem cells cultures that changed to the differentiation medium show an initial decrease in the amplitude values (day 4), as growth is then limited. This initial decrease in cell proliferation is in accordance with other works (Eun et al., 2011). However, after a few hours, Fig. 2 shows a typical linear increase in the monitored amplitude, corresponding to the differentiation process (contrasted with microscope images), reaching final higher amplitude levels than cell cultures that don't differentiate, similar to reported in (Eun et al., 2011; Hildebrandt et al., 2010; Bagnaninchi and Drummond, 2011).

Cellular growth and differentiation was observed with microscope images, as shown in figure 3. In each medium change, cells were seen under the microscope, and photographs of all wells were taken.

Table 1: Wells used in the 8W10E PET cultureware.

Well	Culture	Measurement of impedance
Well 1	Growth medium	Yes
Well 2	Stem cells without differentiation	Yes
Well 3	Stem cells without differentiation	Yes
Well 4	Stem cells without differentiation	No
Well 5	Differentiation medium	Yes
Well 6	Stem cells for differentiation	Yes
Well 7	Stem cells for differentiation	Yes
Well 8	Stem cells for differentiation	No

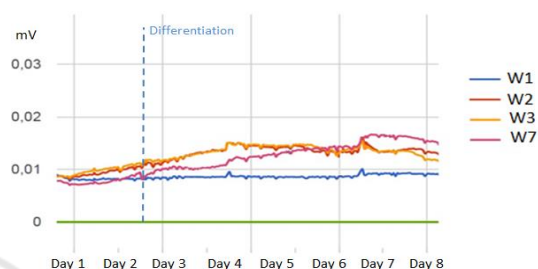

Figure 2: A) Amplitude signals monitored for stem cells without differentiation (W2 W3) and for differentiation (W7). Cell culture medium was also measured (W1). An electrical error was found in W6. After an initial transient regime, all signals corresponding to cell cultures started to rise, corresponding to cellular growth. After differentiation medium was used (Day 2) and after a transitory stop in the measured amplitude corresponding to a decrease in cell proliferation, stem cells following the differentiation process (W7), showing a higher increase in the monitored amplitude.

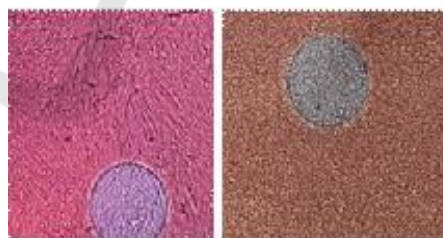

Figure 3: Microscope images of the cell cultures. In each medium change, cells were seen under the microscope, and photographs of all wells were taken. Left) Well 7 (stem cells for differentiation) on the eighth day from the start of differentiation. Tubular structures corresponding to muscle myotubes can be observed. Right) Well 2 (stem cells without differentiation) at the eighth day. Differences between these two different wells are significant, although a more quantitative work should be carried out in the future.

A good level of differentiation was observed at the end of the differentiation process. Tubular structures corresponding to myotubes were clearly

observed at the end of the differentiation process, as shown in Fig. 3.

These results suggest the differentiation in cell lines correspond to differences in bioimpedance measured, although the work should be completed in the future with more quantitative analysis.

4 CONCLUSIONS

A new oscillating circuit based on Impedance Spectroscopy has been presented for the real-time monitoring of the cellular growth and differentiation processes of stem cells. The technique has been first applied to muscle stem cells.

The circuit proved to be useful for monitoring the processes of cell growth and estimating the fill factor of muscular stem cell cultures. The oscillation-based circuit proposed successfully detected this cell growth, in a similar way as in other cell types. A useful threshold for the fill factor of 70% has been positively tested on stem cell-cultures, to activate them towards differentiation by changing the medium.

Real-time monitoring of cell differentiation can be also enabled with the proposed impedance spectroscopy method. An initial decrease in cell proliferation was detected at the change of medium to differentiation medium. However, after a few hours, a linear increase in the monitored amplitude was recorded, corresponding to the differentiation process, which was contrasted with microscope images. A final higher amplitude levels in differentiated cell cultures were detected. The technique could be useful for determining the degree of differentiation achieved, although more detailed tests would be needed.

No significant differences between cell cultures where electrical impedance was used and the control ones. However, higher levels of intensity could be used, which could influence the process of cellular differentiation and facilitate the development of cells, or even facilitate the contraction of muscular structures, what could be of importance in the design of new bioreactors for tissue engineering.

ACKNOWLEDGMENT

This work was supported in part by the Spanish founded Project: Integrated Microsystems for cell culture test (TEC2013-46242-C3-1-P): Spanish, co-financed with FEDER program.

REFERENCES

- Applied Biophysics, <http://www.biophysics.com/>.
- Bagnaninchi, P. O., and Drummond, N., 2011. "Real-time label-free monitoring of adipose-derived stem cell differentiation with electric cell-substrate impedance sensing". *Proceedings of the National Academy of Sciences of the United States of America* 108 (16), 6462-6467.
- Cheema, U., Yang, S. H., Mudera, H., Goldspink, G. G., Brown, R. A., 2003. "3-D in vitro model of early skeletal muscle development". *Cell Motil. Cytoskeleton* 54, 226-23.
- Daza, P., Olmo, A., Cañete, D., Yúfera, A., 2013. "Monitoring living cell assays with bio-impedance sensors". *Sensors and Actuators B: Chemical*. 176, 605-610.
- Eun, P. H., Donghee, K., Sook, K. H., Cho, S., Jung-Suk, S., K., Young, K. J., 2011. "Real-time monitoring of neural differentiation of human mesenchymal stem cells by electric cell-substrate impedance sensing," *Journal of biomedicine & biotechnology*. ID 485173.
- Giaever, I., Keese, C. R., 1984. "Monitoring fibroblast behavior in tissue culture with an applied electric field," *Proc Natl Acad Sci USA*. 81, 3761-3764.
- Hildebrandt, C., Büth, H., Cho, S., Impidjati, Thielecke, H., 2010. "Detection of the osteogenic differentiation of mesenchymal stem cells in 2D and 3D cultures by electrochemical impedance spectroscopy" *Journal of Biotechnology* 148, 83-90.
- Huertas, G., Maldonado-Jacobi, A., Yúfera, A., Rueda, Huertas, J- L., 2015. "The Bio-Oscillator: A Circuit for Cell-Culture Assays," *IEEE Transactions on Circuits and Systems. Part II: Express Briefs*. 62, 164-168.
- Liao, H., Zhou, G. H., 2009. "Development and progress of engineering of skeletal muscle tissue" *Tissue Eng. Part B Rev*. 15, 319-331.
- Nordberg, R. C., Zhang, J., Griffith, E. H., Frank, M. W., Starly, B., Lobo, E. G., 2017. "Electrical Cell-Substrate Impedance Spectroscopy can monitor age-grouped human adipose stem cell variability during osteogenic differentiation," *Stem Cells Translational Medicine* 6 (2), 502-51.
- Pérez, P., Maldonado, A., Yúfera, A., Huertas, G., Rueda, A., Huertas, J. L., 2016. "Towards Bio-impedance Based Labs: A Review". *Journal of Electrical Engineering*. 4 (3), 116-127.
- Pérez, P., Maldonado, A., López, A., Martínez, C., Olmo, A., Huertas, G. and Yúfera, A., 2017. "Remote Sensing of Cell Culture Assays. Cell Culture," *Chapter 4 In: New Insights in Cell Culture Technology*. 135-155. InTech Europe.
- Somers, S. M., Spector, A. A., DiGirolamo, D. J., Grayson, W. L., 2017. "Biophysical stimulation for engineering functional skeletal muscle," *Tissue Eng Part B Rev*. 23 (4), 362-372.