

PDF hosted at the Radboud Repository of the Radboud University Nijmegen

The following full text is a publisher's version.

For additional information about this publication click this link.

<http://hdl.handle.net/2066/27243>

Please be advised that this information was generated on 2017-12-05 and may be subject to change.

ISOLATION OF LARGE NUMBERS OF HIGHLY PURIFIED LYMPHOCYTES AND MONOCYTES WITH A MODIFIED CENTRIFUGAL ELUTRIATION TECHNIQUE

CARL G. FIGDOR, WILLY S. BONT, JAN E. DE VRIES and WIM L. VAN ES

Departments of Biophysics and Immunology, The Netherlands Cancer Institute, Plesmanlaan 121, 1066 CX Amsterdam, The Netherlands

(Received 17 June 1980, accepted 13 October 1980)

A modified centrifugal elutriation technique is described for the isolation of large numbers of lymphocytes and monocytes. Elutriation was carried out by lowering the rotor speed at a constant flow rate which was generated by hydrostatic pressure. The flow rate could be kept constant if the separation procedure was performed at high pressure and high systemic resistance.

Up to 2.3×10^9 mononuclear cells derived from 2000 ml blood were separated in one single experiment in approximately 1 h. The lymphocytes and monocytes were isolated at purities of $98 \pm 1\%$ and $94 \pm 1\%$ respectively. The purity of the lymphocytes was increased to $99.8 \pm 0.1\%$ by a second elutriation run. Additional advantages of the elutriation procedures are that the choice of medium is free, and that relatively large numbers of cells may be separated with high recoveries.

INTRODUCTION

To investigate the function of monocytes (Fleer et al., 1978; Muchmore et al., 1979; Niederhuber et al., 1979; Rosenstreich and Mizel, 1979) and their interactions with lymphocytes (Hersh and Harris, 1968; Feldmann, 1972; De Vries et al., 1979; Galili et al., 1979) it is a prerequisite to obtain both mononuclear cell populations in as pure a state as possible. In order to prevent loss of functional properties of these cells, the time of separation has to be as short as possible. In addition, large numbers of highly purified cells are required for most in vitro testing. To fulfill these requirements centrifugal elutriation was chosen to separate human lymphocytes and monocytes. This method has the advantage that there is $>95\%$ recovery of all cells present in the cell sample, that the viability of recovered cells is high and that their functional properties are not affected (Sanderson et al., 1977; Jemionek et al., 1979; Meyskens et al., 1979; Norris et al., 1979).

Currently most separations with the elutriator rotor are carried out by variation of the flow rate at a constant rotor speed. We, in contrast, have focussed attention on elutriation by variation of the rotor speed at a constant flow rate, which required a number of modifications concerning

both rotor speed and flow rate (Van Es and Bont, 1980). In the present paper we describe the optimal conditions for the generation of a stable flow by hydrostatic pressure and the large scale separation of highly purified monocytes and lymphocytes in approximately 1 h.

MATERIALS AND METHODS

Medium

The elutriation was carried out in phosphate-buffered saline (PBS) supplemented with 2% fetal calf serum (FCS), penicillin (100 IU/ml), streptomycin (100 μ l/ml) and fungizone (0.25 μ g/ml). This elutriation medium is referred to as 'medium'. Prior to the addition of FCS and antibiotics the PBS was sterilized by autoclaving, which also prevented generation of air bubbles during elutriation.

Mononuclear cell preparations

A volume of 500–2000 ml freshly drawn ACD-blood (Roos and Loos, 1970) from 1–4 healthy donors was collected and centrifuged at $1000 \times g$ for 20 min. The buffy coat cells (BC 1) were collected and a second buffy coat was prepared from the BC 1 cells by centrifugation at $1000 \times g$ for 20 min. These buffy coat cells (BC 2) were collected, diluted (1 : 3) with medium and centrifuged over a Ficoll/Hypaque mixture for 20 min at $1000 \times g$ (Böyum, 1968). The mononuclear cells were collected, washed once with medium, counted and resuspended in 10–30 ml medium.

Centrifugal elutriation

A Beckmann J21C centrifuge equipped with a JE-6 elutriation rotor was modified as described previously (Van Es and Bont, 1980). The flow was generated by means of hydrostatic pressure, P , and not by a pump (Fig. 1). A selected flow rate was set and kept constant with the clamp, C .

The introduction of the cell sample was largely simplified by utilizing the reservoir (R_2) which has a spiral glass tube with a volume of approximately 40 ml. After closing t_2 , the cell sample was introduced into the spiral tube by means of a syringe. Because of its higher density, the cell suspension replaced the medium in the spiral without mixing.

After introduction into the rotor the cell suspension was fractionated by a stepwise decrease of the rotor speed at a constant flow rate. The different fractions were collected in volumes of 150 ml.

During elutriation, the centrifuge was cooled to 4°C , while the reservoirs R_1 and R_2 were cooled with water to 4°C . The elutriation procedures could also be carried out under sterile conditions. Autoclaving of all tubes and glassware, and extensive rinsing of the rotor and other non-autoclavable parts with 70% ethanol was sufficient to allow long-term culture (up to 9 days) of the fractionated cells without infection.

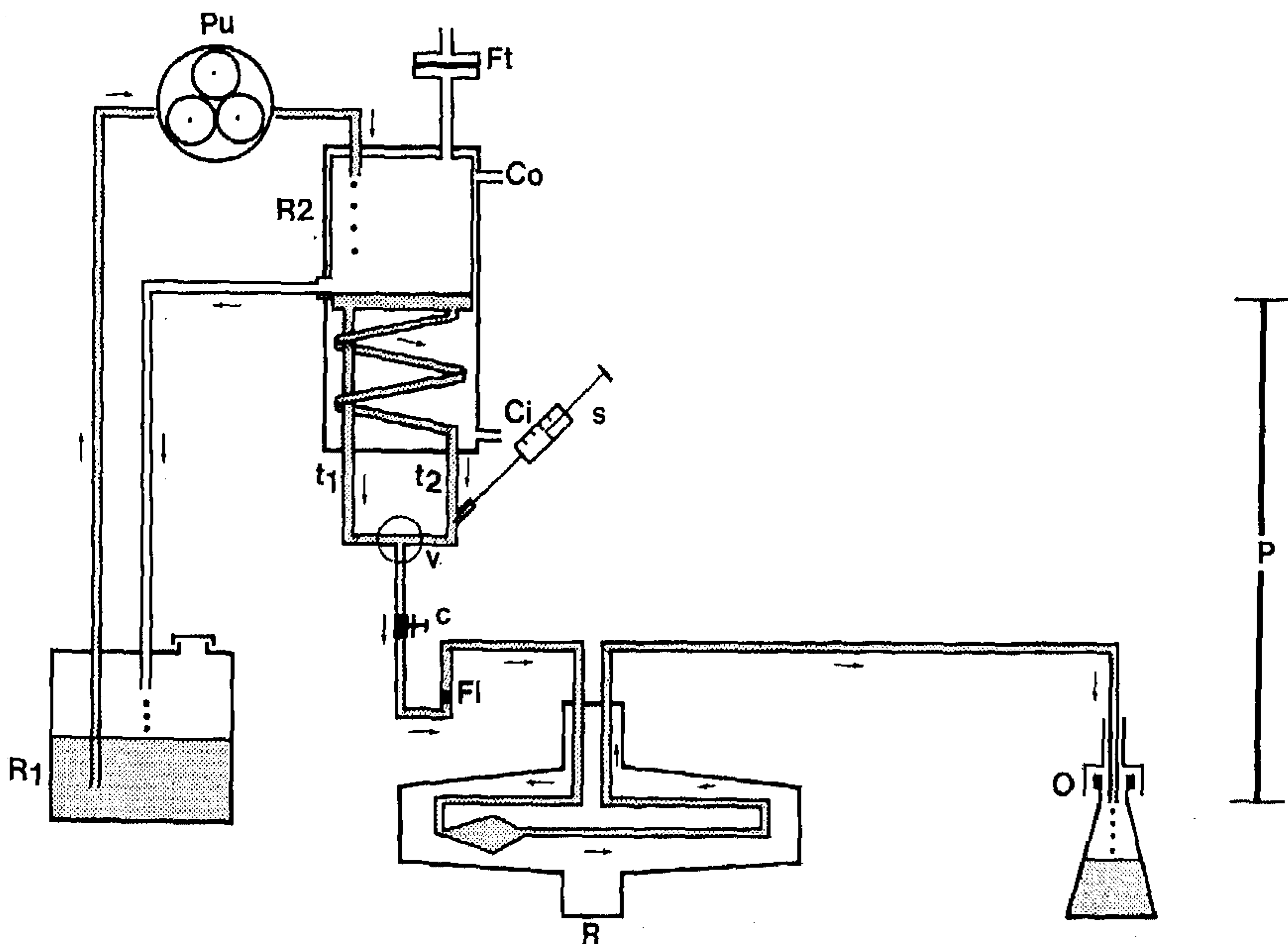

Fig. 1. Schematic representation of the elutriation system. Elutriation was carried out by variation of the rotor speed at a constant flow rate. The flow rate was generated by hydrostatic pressure, P , in the following way. Medium was pumped from reservoir, R_1 , into reservoir R_2 . The level of the medium in R_2 was kept constant by an overflow leading the medium back to R_1 . The pressure, P , was determined by the difference in height between the level in R_2 and the outlet, O . The direction of flow is indicated by arrows. A selected flow rate was set with clamp, C , and monitored with a flow meter, FI . At a certain flow rate the relative quantities of medium passing tube 1, t_1 , and the spiral tube 2, t_2 , is regulated with valve, v . Before the sample was introduced with the syringe, s , into t_2 , this tube was closed. The cell sample was introduced into the rotor, R , by opening t_2 . Samples containing high cell concentrations cannot be introduced as they are, but require dilution to prevent overloading. This can be accomplished by opening t_2 only partly, so that the sample is diluted with medium from t_1 , the resultant flow rate always remaining constant. The elutriated cells leaving the rotor are collected at the outlet, O . Since the overflow acts in the same way as a filter pump, the air-pressure in R_2 will decrease. In order to prevent this, air must be freely admitted via the sterilization filter, F_t . A separate cooling system was used to keep the temperature of R_2 at 4°C . C_i = inlet of cooling water; C_o = outlet of cooling water.

Characterization of the lymphocytes and monocytes

Lymphocytes and monocytes were differentiated according to the following criteria.

- (1) May-Grünwald-Giemsa (MGG) staining of cytocentrifuge preparations.
- (2) Staining for non-specific cytoplasmic esterase (Yam et al., 1971).
- (3) Electronic sizing with a Coulter counter ZF with a pulse height analyzer, Chanalyzer model C-1000 (Loos et al., 1976).
- (4) Phagocytosis of fluorescent carboxylated latex beads of average diam-

eter 1.6 μm (Polysciences, Warrington, PA, U.S.A.), opsonized with human IgG. Phagocytosis was carried out in 100% FCS for 20 min.

Functional activities of the isolated lymphocytes

The functional activities of the purified lymphocytes (fraction 2 cells) were assayed by measuring their proliferation after stimulation with PHA (1 $\mu\text{g}/\text{ml}$, Wellcome, Beckenham, U.K.) as described previously (De Vries et al., 1979). Briefly, 1×10^5 lymphocytes were cultured in Dulbecco's modification of Eagle's Minimal Essential Medium (DMEM) supplemented with antibiotics and 10% heat inactivated (30 min, 56°C) fetal calf serum (FCS) in flat-bottomed microtiter plates (Microtest IITM, No. 3040, Falcon Plastics, Oxnard, CA). After 3 days' incubation at 37°C in a humidified atmosphere of 5% CO_2 and air, the cultures were labeled for 2 h with 0.4 μCi [^3H]thymidine ([^3H]Tdr, 6.7 Ci/mmol) harvested with an automated sample harvester and counted in a liquid scintillation counter.

Functional activities of the purified monocytes

In addition to their phagocytic properties and their helper functions in lymphocyte activation by mitogens, monocytes were tested for their antibody-dependent cellular cytotoxicity (ADCC) in a ^{51}Cr release assay in which antibody-coated human and chicken erythrocytes (CE) were used as target cells. 10^9 human erythrocytes (HE) were resuspended in 0.2 ml medium and labeled with 100 μCi ^{51}Cr (sodium chromate, New England Nuclear, Boston, MA) for 60 min at 37°C . During the last 30 min of the labeling period, 0.2 ml of undiluted anti-D antibody (Central Laboratory of the Red Cross Blood Transfusion Service, Amsterdam, The Netherlands) was added to the HE. An identical ^{51}Cr labeling procedure was used for the CE which were coated with a rabbit anti-CE IgG (Cappel Laboratories, Downington, PA) in a final dilution of 1 : 100. The ^{51}Cr -labeled antibody-coated HE and CE were washed 3 times with PBS and 5×10^5 erythrocytes (in 100 μl medium) were seeded per well of a U-bottomed microtiter test plate (Linbro, No. 76-213-05, Hamden, CT). Effector cells were added in a concentration of 5×10^5 in 100 μl medium. The plates were centrifuged for 2 min at $150 \times g$ and incubated for 24 h at 37°C in 5% CO_2 . At the end of incubation the plates were centrifuged for 2 min at $150 \times g$ and 100 μl supernatant was collected and counted in a gamma counter. The ADCC was expressed as the percentage of ^{51}Cr release which was calculated as follows: $(A - B/T - B) \times 100$, where A = mean cpm of test sample; B = mean cpm of spontaneous ^{51}Cr release (i.e. ^{51}Cr released by the labeled target cells in medium only); T = mean cpm of the maximal ^{51}Cr release which was obtained after addition of 1% Triton-X to the target cells. The average spontaneous release \pm S.D. for HE and CE was $8 \pm 2\%$ and $4 \pm 1\%$ respectively.

RESULTS

Factors influencing the flow rate

Optimal and reproducible cell separations require a constant flow rate. Therefore we determined the factors which influence the flow rate (F) if hydrostatic pressure (P) is used instead of a pump. The relationship between P and F is determined by the equation:

$$P = R_t F \quad (a)$$

where R_t is the total resistance. From (a) it follows that when P is constant, F is influenced only by R_t . The total resistance, R_t , is composed of a constant resistance (R_c) determined by the system itself (tubing etc.) and a variable resistance (R_v) which is determined by the cell load, cell clumps in the sample, cell size and rotor speed. This implies that F is influenced by R_v . The effects of R_v on F can be minimized if elutriation is carried out at relatively high R_c values, which can be reached at high P values (see a). The optimal R_c value at which the influence of R_v on F is negligible may be determined by varying R_c by widening or narrowing the tubing with the

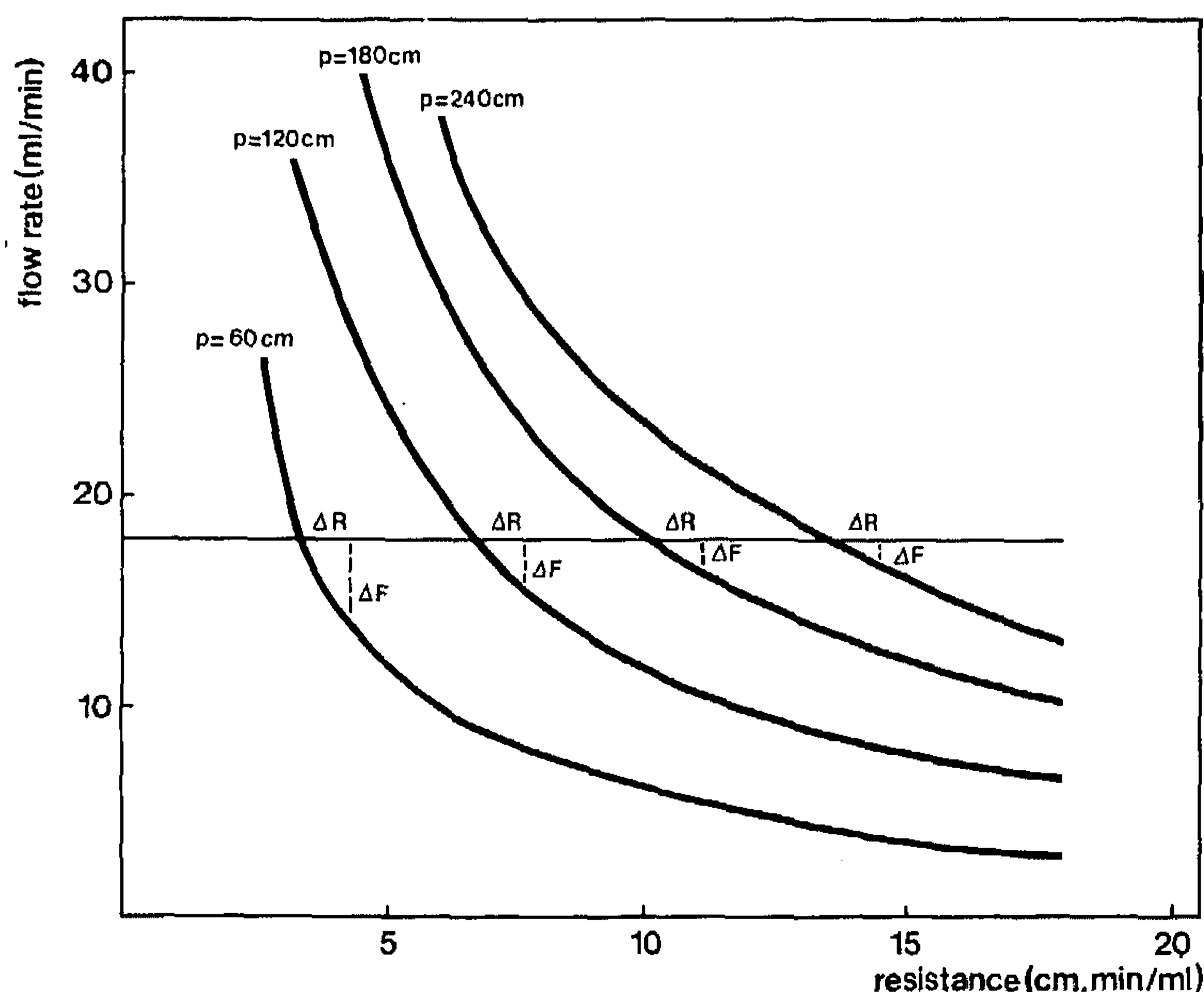

Fig. 2. Flow rate, F , as a function of the resistance, R , at 4 different pressures. The resistance, R_c , was changed by widening or narrowing the clamp, C (see Fig. 1). At a certain setting of the clamp the flow rate was measured at the 4 pressures, P . The R -values were calculated with the aid of equation (a): $R = P/F$. The decrease in F , ΔF , due to an increase of R , ΔR , during the introduction of the sample is illustrated. Since our experiments were carried out at 18 ml/min, the effect of $\Delta R = 1 \text{ cm} \cdot \text{min/ml}$ is shown at this flow rate and illustrates that ΔF is smaller at high P values.

clamp, C. The results are shown in Fig. 2, where F is measured at the 4 pressures 60, 120, 180 and 240 cm respectively. Fig. 2 shows that F is minimally influenced and more stable at high R_c and P values. Furthermore, the four curves have the form predicted by equation (a). The slope of these curves representing the change in flow by the change in resistance is given by:

$$\frac{dF}{dR_t} = -\frac{F}{R_t} = -\frac{F}{R_c + R_v} \quad (b)$$

From (b) it follows that at a certain flow rate, F , the influence of R_v on the total resistance R_t is negligible at relatively high R_c values, which is in agreement with the results shown in Fig. 2.

Further, we investigated whether F was influenced by the speed of rotation. The variations in preset flow rates of 5, 10, 15 and 30 ml/min were measured at different rotor speeds. Fig. 3 shows that at flow rates lower than 10 ml/min, no influence of the rotor speed on F could be measured. At higher flow rates the effect of the speed of rotation could be neglected if rotor speeds of more than 1500 rpm were used (Fig. 3).

From these observations it is concluded that whatever the cause of the increase in resistance, the influence on the flow rate was minimized if elutriation was carried out at high P and high R_c values.

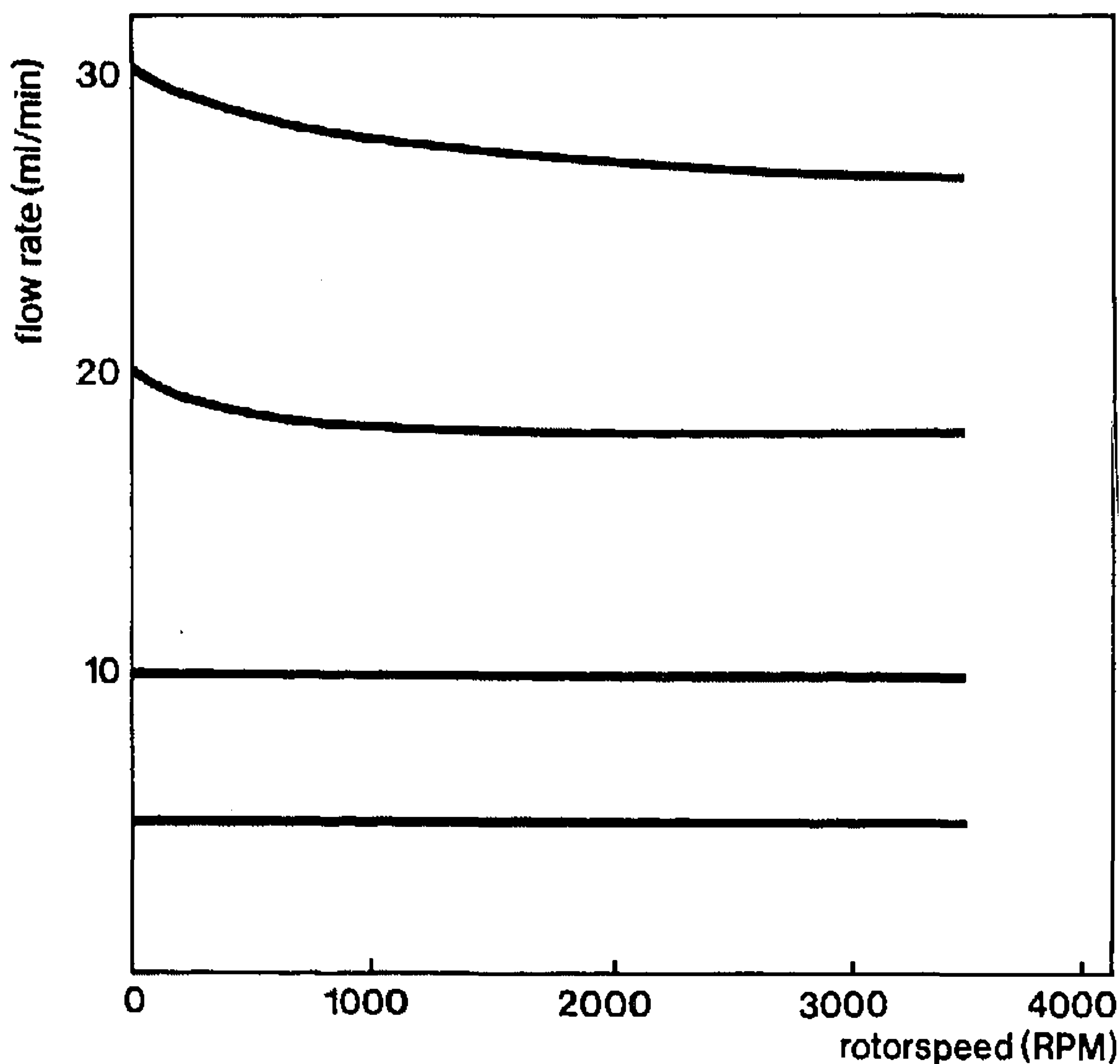

Fig. 3. Flow rate as a function of rotor speed. At a pressure of 180 cm the flow rate, F , was set at 4 values with clamp C (see Fig. 1). At each setting of the clamp the flow rate was measured as a function of rotor speed.

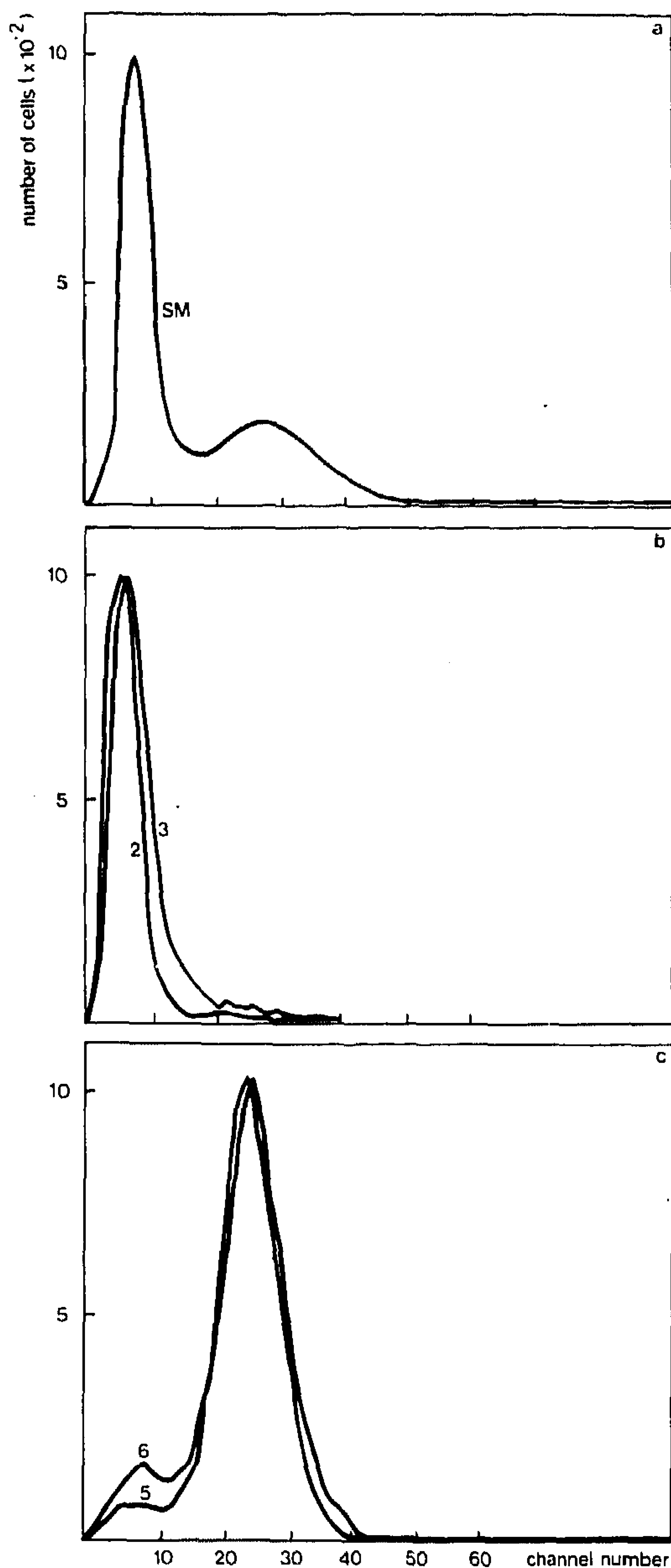

Fig. 4. Electronic size distribution profiles of mononuclear cells. The size distribution profiles of the starting material and of various fractions were determined with a channel analyzer. a: starting material (SM). b: fractions 2 and 3 which contained 97% of all lymphocytes recovered. c: fractions 5 and 6 which contained 69% of all monocytes recovered. The fractions 1, 4 and 7 are not shown because on average they contained less than 10% of the recovered cells.

Isolation of lymphocytes and monocytes

To investigate whether it was possible to isolate highly purified lymphocytes and monocytes with this modified elutriation technique, mononuclear cell suspensions from 500 ml blood were prepared as described in Materials and methods. The flow rate used in these experiments was 18 ml/min at a hydrostatic pressure of 180 cm. The sample (10 ml) was introduced into the rotor at 3200 rpm. At this speed the platelets were elutriated. By subsequently lowering the rotor speed to 2550, 2400, 2300, 2150, 2000, 500 rpm respectively, another 6 fractions were obtained. The whole separation procedure was performed in approximately 1 h.

The size distribution (Fig. 4) profiles of the different fractions show that efficient separation of the lymphocytes and monocytes was obtained. Further characterization of the different fractions (Table 1) showed that the cell sample contained $29 \pm 4\%$ monocytes. All platelets, contaminated with a few lymphocytes, were recovered in fraction 1. Fraction 2 contained $82 \pm 3\%$ of all lymphocytes recovered. The purity of the lymphocytes was $98 \pm 1\%$.

Highly enriched monocytes were recovered in fractions 5 and 6. The purity of the monocytes in these fractions was $93 \pm 3\%$ and $88 \pm 3\%$ respectively, whereas 65–80% of all monocytes recovered from the rotor were obtained in these fractions. Fractions 4 and 7 contained only $9 \pm 3\%$ of all cells recovered and comprised mixed populations of mononuclear cells and granulocytes. The viability of all cell fractions was $>99\%$ as judged by trypan blue exclusion.

TABLE 1

Characterization of the isolated fractions. Values shown represent mean \pm S.E.M.

	MGG-staining ^a			Phago- cytosis ^b	Esterase ^c	Recovery ^d		
	% Ly	% Mo	% Gr			% Ly	% Mo	% Gr
Starting material	65 ± 4	29 ± 4	6 ± 2	30 ± 1	35 ± 3			
Fraction 1	<1	—	—	ND	ND	<1	—	—
2	98 ± 1	<1	—	1 ± 1	<1	82 ± 3	<1	—
3	91 ± 2	8 ± 2	<1	8 ± 6	9 ± 3	15 ± 2	5 ± 1	—
4	30 ± 9	69 ± 9	1 ± 1	76 ± 11	73 ± 10	<1	10 ± 4	3 ± 1
5	4 ± 1	94 ± 1	1 ± 1	90 ± 3	93 ± 3	<1	50 ± 9	6 ± 1
6	2 ± 1	90 ± 1	8 ± 1	85 ± 9	88 ± 3	<1	23 ± 6	21 ± 8
7	7 ± 3	48 ± 8	48 ± 9	ND	57 ± 6	<1	8 ± 4	66 ± 5

^a The starting material and 7 different fractions were differentiated after MGG-staining.

^b % cells phagocytosing fluorescent beads.

^c % esterase positive cells.

^d Percentages of the number of lymphocytes, monocytes and granulocytes recovered: in all cases at least 300 cells were counted.

TABLE 2

[³H]Thymidine incorporation of the unfractionated lymphocytes, the lymphocyte fraction and the monocyte fraction, and the effect of addition of autologous monocytes to the lymphocyte fraction.

Mononuclear cell preparation	[³ H]thymidine incorporation × 10 ³ (mean ± S.D. of 3 different donors)
Unfractionated lymphocytes (35% monocytes)	53.2 ± 8.6
Fraction 2 (1 ± 1% monocytes)	29.4 ± 6.2
Fraction 5 (93 ± 3% monocytes)	0.5 ± 0.1
Fraction 2 + 10% fraction 5	62.8 ± 8.0

Functional activities of the isolated lymphocytes

The average [³H]TdR incorporation of the purified lymphocyte fraction (fraction 2) was approximately 55% of the average [³H]TdR incorporation of the corresponding unfractionated lymphocytes (UL) (Table 2). The reduced proliferative responses of the fraction 2 cells were, however, not due to cell damage caused by the separation procedure, but to suboptimal monocyte concentrations, since addition of 10% autologous fraction 5 cells (containing 93 ± 3% monocytes) resulted in an average [³H]TdR incorporation which was higher than that of the corresponding UL (Table 2). These results indicate that both the fraction 2 (98 ± 1% lymphocytes) and fraction 5 cells were functionally active.

Functional activity of the purified monocytes

The phagocytic capacity of the monocytes (Table 1) and their helper function in the activation of lymphocytes by mitogens were not affected by the separation procedure (Table 2).

TABLE 3

ADCC of the unfractionated lymphocytes and the various lymphocyte and monocyte fractions on human and chicken erythrocytes.

Mononuclear cell preparation	Spontaneous cytotoxicity and ADCC % specific ⁵¹ Cr release			
	HE		CE	
	—ab ^a	+ab	—ab	+ab
Unfractionated lymphocytes (25% monocytes)	1.0	8.5	0.8	15.4
Fraction 2 (1% monocytes)	N.T.	—5.0	N.T.	—0.9
Fraction 5 (92% monocytes)	0.2	43.0	4.3	57.0
Fraction 6 (86% monocytes)	N.T.	33.4	N.T.	42.2

^a Cytotoxicity was measured on target cells coated with the appropriate antibody (+ab) or in the absence of antibody (—ab). Effector: target cell ratio was 1 : 1.

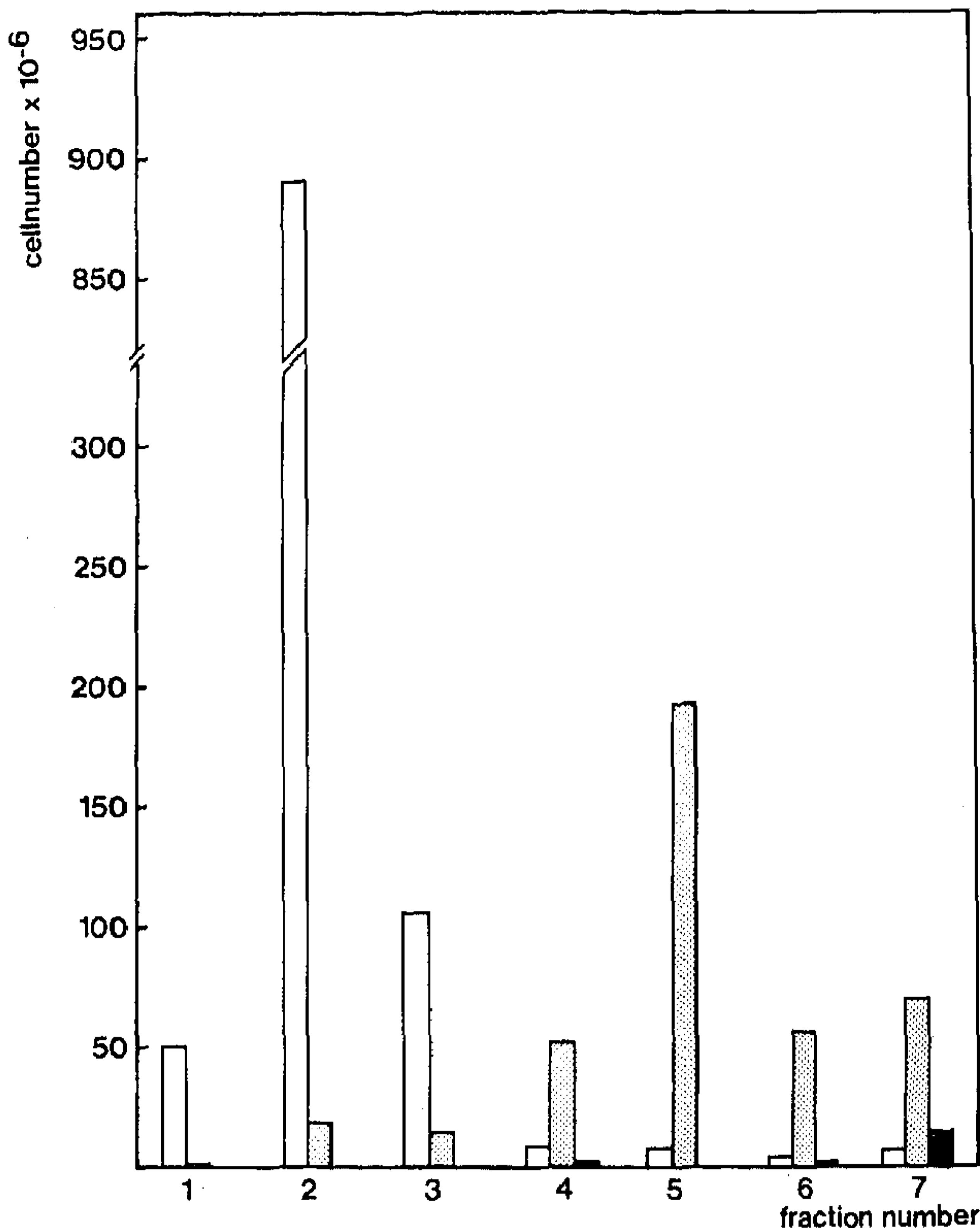

Fig. 5. Distribution profiles of lymphocytes, monocytes and granulocytes in the various fractions obtained after elutriation. 1.6×10^9 cells containing 71% lymphocytes, 27% monocytes and 2% granulocytes were separated. Open bars = lymphocytes; dotted bars = monocytes; solid bars = granulocytes.

In addition it is shown in Table 3 that ADCC of the monocyte fractions 5 and 6 on antibody-coated HE and CE was 4–5 times higher than ADCC of the corresponding UL, indicating that also this monocyte function was not disturbed by the elutriation procedure.

Estimation of maximum loading capacity

In order to determine the maximum capacity of the separation chamber the mononuclear cells of 4 units of blood (1 unit = 500 ml) were separated. Highly enriched lymphocyte and monocyte populations were isolated (Fig. 5). Identical results were obtained if 1 or 2 units of blood were separated (data not shown), which implies that the resolution was not affected by the number of cells in the sample. Furthermore, these results indicate that the separation chamber was not overloaded and that large numbers of mononuclear cells can be separated. In one single run, up to 2.3×10^9 mononuclear cells were separated, resulting in recoveries of $800\text{--}1500 \times 10^6$ (98%) pure lymphocytes and $150\text{--}250 \times 10^6$ (93%) pure monocytes.

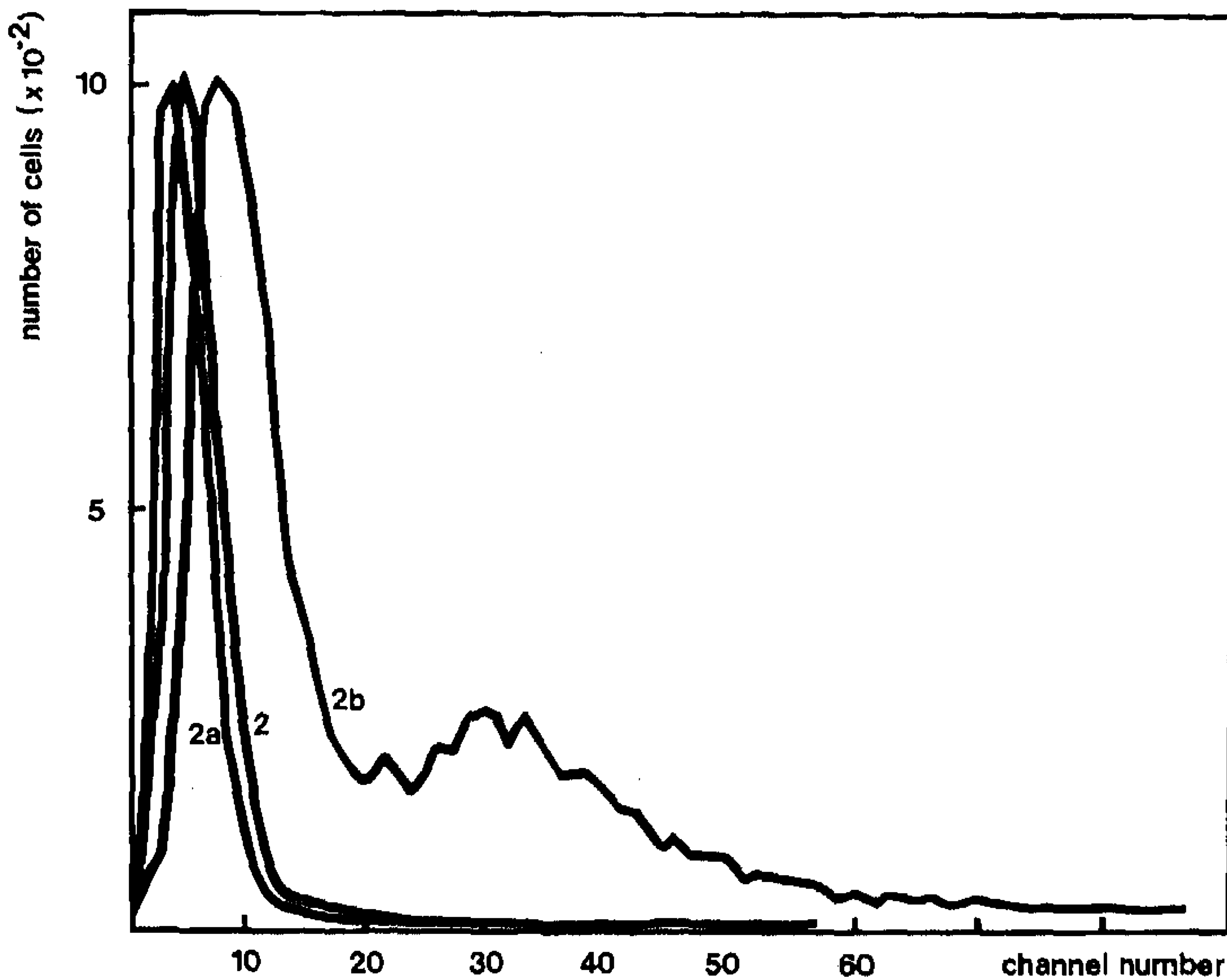

Fig. 6. Size distribution profiles of lymphocytes after a second elutriation run. To remove contaminating monocytes, fraction 2 (see Fig. 4) was elutriated a second time at 2550 rpm. The lymphocytes elutriated at this speed (fraction 2a) contained only 0.1% monocytes as judged by both esterase and MGG staining (1000 cells counted). The remaining cells (fraction 2b) were elutriated at 500 rpm and consisted of intermediate-sized lymphocytes and monocytes (20%).

Isolation of very pure lymphocytes by two subsequent elutriation runs

Since in certain experiments absolutely pure lymphocytes are required, we tried to remove the few contaminating monocytes present in fraction 2 by a second elutriation run. Fig. 6 shows that contaminating monocytes were removed by a second elutriation run at 2550 rpm.

DISCUSSION

For separation based on differences in size of human mononuclear leucocytes from peripheral blood, good results have been obtained by velocity sedimentation procedures. However, such techniques have the disadvantage that density gradients of expensive media are required for stabilization of the sedimentation process. Nevertheless, $1 \times g$ sedimentation techniques have been shown to be powerful methods for separation of relatively small numbers (up to 2×10^8) of mononuclear cells (Bont and De Vries, 1979). For separation of large numbers of mononuclear cells at $1 \times g$, larger vessels and larger quantities of expensive gradient media are required, and the sedimentation times for optimal separations are increased (Bont et al., 1979). Therefore, if large numbers of mononuclear cells have to be separated in a relatively short time, centrifugal elutriation seems to offer the best

prospects (Sanderson et al., 1977). To exploit fully the potentialities of this method, rapid and reproducible setting of rotor speed and constancy of flow rate are a prerequisite. These aspects of centrifugal elutriation have been discussed previously (Van Es and Bont, 1980). The constancy of the flow rate required for optimal cell separation is strongly affected by clogging of the channels in the separation chamber, which is a serious problem if the flow is generated by hydrostatic pressure instead of by a pump (Van Es and Bont, 1980). Minor clogging by clumps of cells (or by large cells) results in an increase of the resistance which causes a decrease in flow rate (see a), and this in turn enhances the clogging by smaller cell aggregates and smaller cells which again cause a further increase in resistance. The result of this cascade effect is that the flow stops completely within a few minutes after introduction of the cell sample. However, our analysis of the factors which influence the flow rate showed that the effect of clogging is negligible if elutriation is carried out at relatively high pressures and high resistances. A second factor which influences the constancy of the flow rate is speed of rotation. We found that speed of rotation did not influence flow rates lower than 10 ml/min. The constancy of the flow rate was only affected if flow rates higher than 10 ml/min and rotor speeds lower than 1500 rpm were used. Therefore the separation of mononuclear cells in the present experiments was not influenced by rotor speed since this was always above 1500 rpm. If cells larger than monocytes have to be separated, and as a consequence a speed lower than 1500 rpm may be required, low flow rates are preferable.

We demonstrate that with this modified elutriation technique large numbers of mononuclear cells can be separated into almost pure lymphocyte and highly purified monocyte populations, both of which are viable and functionally active. Addition of 10% autologous monocyte fraction cells to the lymphocyte fraction resulted in an even higher [³H]TdR incorporation than corresponding unfractionated cells (UL), illustrating that both lymphocyte proliferation and monocyte help after PHA stimulation were not affected by the elutriation procedure. In addition it was shown that the ADCC of the monocyte fractions 5 and 6 was 4–5 times higher than the ADCC achieved with the UL.

The resolution was not influenced by the cell load since no difference in purity of the lymphocyte and monocyte populations was observed whether one unit or four units of blood were separated. By replacing the bypass chamber with a second separation chamber, two separation chambers could be used for the elutriation procedure (Grabske, 1978). The purity of the isolated lymphocyte and monocyte populations was not increased by this procedure (data not shown). This indicated that maximal loading capacity was not reached at a cell load of 2.3×10^9 mononuclear cells (corresponding to 4 units of blood). Although the high cell load did not cause overloading, it probably influenced the density in the separation chamber. The purity of the lymphocyte fraction was improved after a second elutriation run. This may be explained by the fact that in the first elutriation run at 3200 rpm,

many more cells were present in the separation chamber than in the second run. This resulted in an increase in density, which influenced separation in such a way that a fraction of the monocytes floated (as a buffy coat) on top of the lymphocytes and were subsequently elutriated together with these lymphocytes.

In the second elutriation run, carried out with fraction 2 cells only, the density in the separation chamber was not significantly affected, because of the lower cell load. Consequently the contamination with monocytes was considerably lower. Further studies concerning the influence of density on the separation of subpopulations of lymphocytes and monocytes are in progress.

The results presented here indicate that large numbers of lymphocytes and monocytes can be separated in a single elutriation run. This may be of importance when large numbers of these cells are required for in vitro testing. It is concluded that elutriation by changing the speed of rotation at a pulseless constant flow rate created by hydrostatic pressure is a good alternative to changing the flow rate by using a pump at a constant rotor speed.

These results clearly demonstrate that, especially if large numbers of mononuclear cells have to be separated, centrifugal elutriation is a rapid and powerful method.

ACKNOWLEDGEMENTS

We thank Elisabeth Martens for her technical assistance and Marie Anne van Halem for her secretarial help.

This work was supported by the fund: "Geven voor Leven" XV-3.

REFERENCES

- Bont, W.S. and J.E. De Vries, 1979, in: *Cell Populations*, ed. E. Reid (Ellis Horwood, Chicester) p. 53.
- Bont, W.S., J.E. De Vries, M. Geel. A. Van Dongen and H.A. Loos, 1979, *J. Immunol. Methods* 29, 1.
- Böyum, A., 1968, *Scand. J. Clin. Lab. Invest.* 21 (Suppl. 97), 77.
- De Vries, J.E., A.P. Caviles, Jr., W.S. Bont and J. Mendelsohn, 1979, *J. Immunol.* 122, 1099.
- Feldmann, M., 1972, *J. Exp. Med.* 135, 1049.
- Fleer, A., M.L.J. Van Schaik, A.E.G.Kr. Von dem Borne and C.P. Engelfriet, 1978, *Scand. J. Immunol.* 8, 515.
- Galili, U., L. Rosenthal, N. Galili and E. Klein, 1979, *J. Immunol.* 122, 878.
- Grabske, R.J., 1978, *Fractions* 1, 1.
- Hersh, E.M. and J.E. Harris, 1968, *J. Immunol.* 100, 1185.
- Jemionek, J.F., T.J. Contreras, J.E. French and L.J. Shields, 1979, *Transfusion* 19, 120.
- Loos, J.A., B. Blok-Schut, R. Van Doorn and L. Meerhof, 1976, *Blood* 48, 743.
- Meyskens, Jr., F.L., C.A. Kiefer, D.K. Holmes and E.W. Gerner, 1979, *Exp. Hematol.* 7, 401.
- Muchmore, A.V., J.M. Decker and R.M. Blaese, 1979, *J. Immunol.* 122, 61.
- Niederhuber, J.E., P. Allen and L. Mayo, 1979, *J. Immunol.* 122, 1342.
- Norris, D.A., R.M. Morris, R.J. Sanderson and P.F. Kohler, 1979, *J. Immunol.* 123, 166.

- Roos, D. and J.A. Loos, 1970, *Biochim. Biophys. Acta* 222, 565.
- Rosenstreich, D.L. and S.B. Mizel, 1979, *J. Immunol.* 123, 1749.
- Sanderson, R.J., F.T. Shepperdson, A.E. Vatter and D.W. Talmage, 1977, *J. Immunol.* 118, 1409.
- Van Es, W.L. and W.S. Bont, 1980, *Anal. Biochem.* 103, 295.
- Yam, L.T., C.Y. Li and W.H. Crosby, 1971, *Am. J. Clin. Pathol.* 55, 283.