

PDF hosted at the Radboud Repository of the Radboud University Nijmegen

The following full text is a publisher's version.

For additional information about this publication click this link.

<http://hdl.handle.net/2066/24802>

Please be advised that this information was generated on 2017-12-05 and may be subject to change.

LABORATORY INVESTIGATIONS

Repeated enflurane anaesthetics and model predictions: a study of the variability in the predictive performance measures

P. M. VERMEULEN, J. G. C. LEROU, R. DIRKSEN, L. H. D. J. BOOIJ AND G. F. BORM

Summary

We quantified the total variability (reproducibility) and the within-patient but between repeat anaesthetics variability (repeatability) in measures which are used to judge the predictive performance of our physiological model. We studied 14 patients who received enflurane closed-circuit anaesthesia on two occasions. The end-tidal concentrations measured and those predicted served to calculate the predictive performance measures of the model: root mean squared error (rmse=total error), bias (systematic error) and scatter (error around the bias). The overall results were: rmse 15 (7) %, bias 0 (14) % and scatter 9 (3) % (grand mean (total SD)). The within-patient SD values were smaller for the rmse (4%) and bias (10%), but not for scatter (3%). The repeat rmse values and biases were linked to the first results. This implies that these performance measures depended partly on the patient. As there was no association between the personal performance measures and age, sex, body weight, body surface area or body mass index, these characteristics cannot be used to further tune the model. (*Br. J. Anaesth.* 1997; **79**: 488–496).

Key words

Anaesthetics volatile, enflurane. Equipment, breathing systems. Pharmacokinetics, models. Model, physiological.

Using average values of physiological variables and physicochemical data, we have defined a physiological model for closed-circuit inhalation anaesthesia.¹ It is capable of predicting end-expired concentrations after injection of a liquid anaesthetic into a closed-circuit breathing system. Previously we have evaluated the predictive performance of the model by examining the differences between the concentrations predicted and those measured in surgical patients. The observed prediction errors were condensed, per patient, into three single performance measures. These identify the total error size (rmse), systematic error (bias) and error around the bias (scatter). Close agreement between predictions and measurements was found in groups of patients anaesthetized with different volatile anaesthetics.^{2–4}

Yet, if we wish to apply a model in a particular

patient to predict the concentrations of a drug, variability in pharmacokinetic responses must be taken into account. Until now our clinical studies have provided information only on the between-patient variability, expressed in terms of variability in the predictive performance measures of the model, because different patients were studied only once. A major unresolved issue was the repeatability of the performance measures of the model in a patient presenting for repeated anaesthetic procedures.

Therefore, we studied patients who underwent enflurane closed-circuit anaesthesia twice. The objectives were: to evaluate the extent of correspondence between the predictive performance measures of the model obtained in the same patient on two occasions under similar clinical conditions; to determine if these measures varied more among than within patients; and to assess the association of the performance measures of the model with patient characteristics.

Patients and methods

Part of the methods has been described in detail previously and is summarized here together with the details necessary for this specific study.^{1–4}

PATIENTS AND ANAESTHETIC MANAGEMENT

Earlier we completed a validation study of our system model for enflurane closed-circuit anaesthesia in 50 patients. They underwent elective eye surgical procedures, and 15 needed a second surgical intervention of the same type. After approval of the Institutional Ethics and Research Committee, these 15 consenting, Caucasian patients (ASA I or II) were enrolled in the study.

First anaesthetic procedure

Diazepam 5–10 mg and droperidol 2.5–5 mg were given orally 1 h before surgery. Anaesthesia was

P. M. VERMEULEN*, MD, J. G. C. LEROU, MD, PHD, R. DIRKSEN, MD, PHD, L. H. D. J. BOOIJ, MD, PHD, FRCA (Institute for Anaesthesiology); G. F. BORM, PHD (Department of Medical Statistics); University of Nijmegen, The Netherlands. Accepted for publication: May 28, 1997.

*Address for correspondence: Institute for Anaesthesiology, University of Nijmegen, Geert Grooteplein 10, 6500 HB Nijmegen, The Netherlands.

induced with fentanyl 0.1–0.2 mg i.v. and a dose of thiopentone sufficient to abolish the eyelash reflex. Thereafter, vecuronium 0.1 mg kg⁻¹ i.v. was administered. After placement of a cuffed tracheal tube, the lungs of the patients were ventilated artificially with a high fresh gas flow of oxygen and nitrous oxide in a 1:2 ratio until the end-tidal nitrogen concentration was less than 1 vol% or for a maximum of 5 min. Subsequently, the anaesthetic system was closed and closed-circuit anaesthesia commenced. The fresh gas flow of oxygen and nitrous oxide was adjusted manually to maintain the inspired oxygen concentration at 30–40 vol%. The end-tidal carbon dioxide concentration was 4.0–5.0 vol%.

Enflurane anaesthesia was administered using the liquid injection method by the same anaesthetist (P. M. V.). Boluses of liquid enflurane were injected into the expiratory limb of the system: one of 0.02 ml kg⁻¹ (± 0.1 ml) after the start of closed-circuit conditions and repeated increments of 0.01 ml kg⁻¹ during maintenance. We did not use a rigid drug regimen, but modified enflurane administration to provide adequate anaesthesia as in good clinical practice. Therefore, we monitored carefully the patient's response to surgery by assessment of non-invasive arterial pressure measurement, heart rate and heart rate variability judged by ear with the aid of pulse oximetry, and also end-tidal enflurane concentration. Additional i.v. fentanyl 0.05–0.1 mg was given according to clinical needs.

Second anaesthetic procedure

This was separated from the first by at least 2 weeks. Patients received the same premedication. Anaesthesia was induced and maintained as described above. The same parameters for mechanical ventilation (frequency, tidal volume) were used. By design we did not aim to replicate the timetable of enflurane injections from the first anaesthetic. As in the first anaesthetic procedure, individual's anaesthetic needs under given surgical conditions prevailed as necessary.

For both procedures, we noted the times and volumes of liquid enflurane, and total volume administered (ml), and computed the average measured end-tidal enflurane concentration (vol%). To evaluate our anaesthetic management, we also expressed the average measured end-tidal enflurane and nitrous oxide concentrations as multiples of MAC corrected for age (mMAC) and calculated their sum (i.e. total mMAC).⁵ Before evaluating the anaesthetic requirements and calculating the errors of prediction, we curtailed one of the two data files per patient, that is the one with the longest duration. Thus we considered only repeated observations for exactly the same duration.

INSTRUMENTATION

The anaesthetic equipment consisted of an Ohmeda Modulus CD anaesthesia system (Madison, WI, USA) with a standing bellows ventilator (Ohmeda 7850). The delivered tidal volume depends on the rate of fresh gas flow into the standing bellows ventilator.⁶ Consequently, reducing and adjusting

the fresh gas flow in order to provide closed-circuit conditions mostly necessitated frequent adjustments of tidal volume and the flowmeters at the beginning of closed-circuit anaesthesia. Five minutes were required until we were confident that tidal volume was equal during repeated measurements. Therefore, we only analysed data acquired after this initial non-steady state period.

A respiratory mass spectrometer (Centronic 200 MGA or QP9000; CaSE, Gillingham, England) continuously sampled gas at the Y-piece of the anaesthetic circuit via a side-stream sampling port (the sample flow is part of the model). The coefficient of variation of the mass spectrometer readings was 2%. Before starting each measurement we verified calibration of the mass spectrometer for enflurane with a calibration gas mixture containing 1% enflurane in 30% oxygen, 30% nitrous oxide and balance gas nitrogen (AGA Gas, Amsterdam, The Netherlands).

A personal computer system with a 12-bit analogue-to-digital board (Keithley Metrabyte, Taunton, MA, USA) processed the signals from the mass spectrometer. The data acquisition software was developed with the aid of ASYST (Keithley Metrabyte). On-line analysis of the respiratory waveforms allowed continuous monitoring in the operating room of the actual inspired and end-expired concentrations of nitrogen, oxygen, carbon dioxide, nitrous oxide, argon and enflurane. The trends of the inspired and end-expired concentrations of enflurane and oxygen of the last 20 min were also displayed continuously. The last end-expired enflurane concentration was saved for each 10-s period for further data processing.

THE MODEL AND ITS INPUT

The end-expired concentrations measured were compared with those predicted by our system model, version C, which does not assume a zero circulation time and accounts for non-pulmonary elimination of the anaesthetic agent.³ Details of the model and its components are given in appendix 1. Data processing was a three-step process. During step one, the model input was generated by means of an ASYST application program. The model input consisted of

Table 1 Predictive performance measures: pe = prediction error (%), n = number of measurements per patient, pe_i is the i -th prediction error and me = mean prediction error. C_p and C_m = predicted and measured end-tidal concentrations of enflurane

$pe = \frac{C_p - C_m}{C_m} \times 100$	= Prediction error per pair of predicted and measured values
$\sqrt{\frac{1}{n} \sum_{i=1}^n pe_i^2}$	= Rmse = $\sqrt{(\text{Bias}^2 + \text{scatter}^2)}$ total error budget
$me = \frac{1}{n} \sum_{i=1}^n pe_i$	= Bias systematic component of the error
$\sqrt{\frac{1}{n} \sum_{i=1}^n (pe_i - me)^2}$	= Scatter dispersion of the errors (pe) around their mean (me)

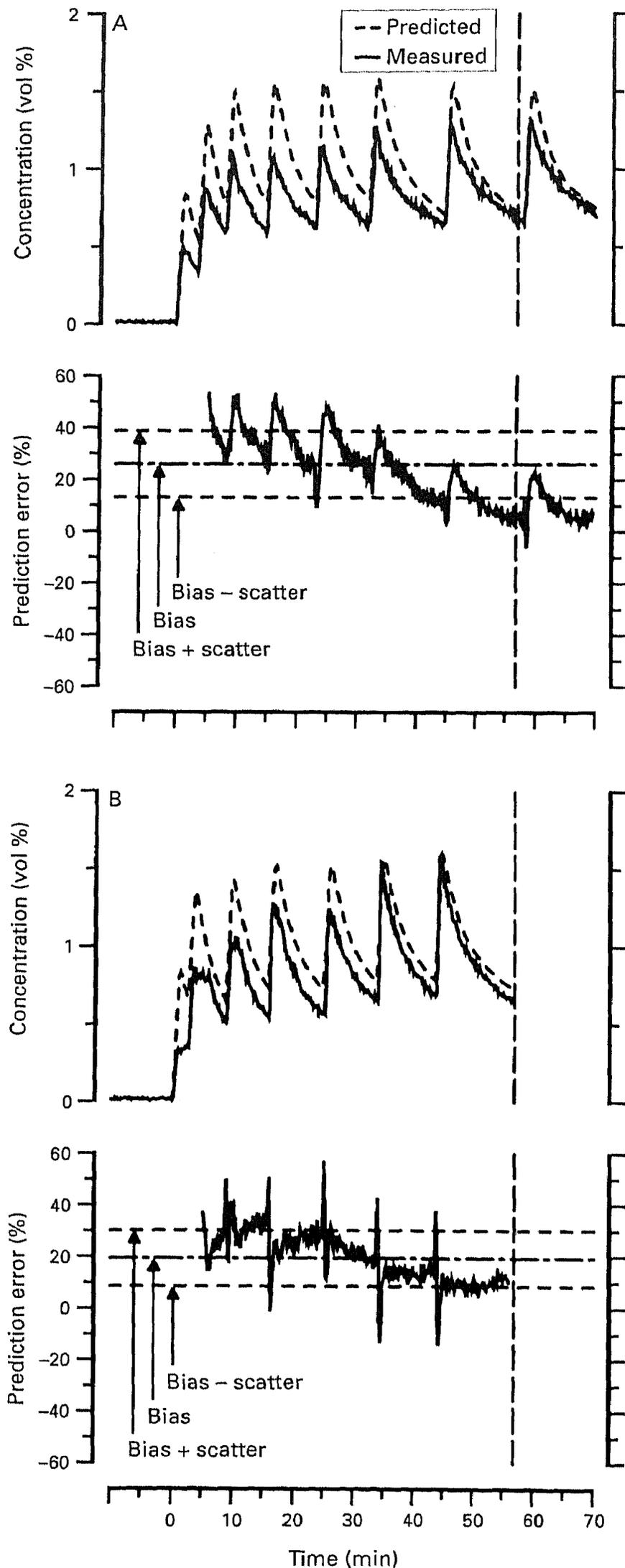

Figure 1 Repeated observations from a 22-yr-old female patient (weight 67 kg, height 1.75 m). A: Predicted and measured end-tidal enflurane concentrations, and prediction errors obtained during the first anaesthetic: one per 10-s period. The observed prediction errors were condensed into three predictive performance measures: total error size (rmse), systematic error (bias) and error around the bias (scatter). These were 29.0%, 26.1%, and 12.8%, respectively. B: The same variables as in (A) obtained during the repeated procedure. Rmse, bias and scatter were 22.2 %, 19.4 % and 10.8 %, respectively. The patient was anaesthetized with 7.0 ml of liquid enflurane administered in seven injections on both occasions. The vertical broken line shows how the data file with the longest duration was curtailed to match the durations of both anaesthetics.

patient data (age, sex, body weight and height) and the enflurane dosing schedule (timetable of injections with the amount of each enflurane increment). The amount of liquid enflurane per injection was converted into millilitres of vapour and supplied to the model as if the vapour were added to the anaesthetic system over a 60-s interval (i.e. the average time period necessary for the enflurane liquid to evaporate).

Throughout step two, our model generated the predicted time courses of the end-expired enflurane concentrations by running a TUTSIM simulation program (Meerman Automation, Neede, The Netherlands). In the final step three, by importing the predicted and measured data into another ASYST application program, the predictive performance measures of the model (see below) were calculated. For each patient and each anaesthetic procedure we predicted the end-expired concentrations by applying our system model.

PREDICTIVE PERFORMANCE MEASURES

Table 1 summarizes the measures which serve to determine the predictive performance of our model. The prediction error (pe) is the difference between a predicted and measured value of enflurane concentration, expressed as a percentage of the measured value: pe and squared prediction error (pe²) are calculated for each time period of 10 s. These two quantities are used to provide the following three predictive performance measures.

(1) Root mean squared error (rmse). The mean squared error (mse) is the average of the squared prediction errors. Rmse is defined as $\sqrt{\text{mse}}$ and is a measure of the total error budget for an individual patient during one anaesthetic procedure. It is not influenced by the sign of the prediction errors and can be formulated as being composed of bias and scatter (table 1).

(2) Bias, that is the average of the prediction errors for an individual patient, is a measure of the systematic component of error. It can be either positive or negative, thus indicating over prediction or under prediction, respectively.

(3) Scatter is a measure of the variation of the prediction errors around their mean (bias) during one procedure.

These three measures were calculated for the first and the repeat anaesthetic procedure. Thus per patient we had a first and repeat rmse, bias and scatter, as illustrated in figure 1.

VARIABILITY MEASURES

The measures we used to describe the variability in the predictive performance measures were in accordance with the recently updated reports of the International Organization for Standardization ISO-5725, part 1 and 2, for repeated measurements.^{7,8} Detailed information is given in appendix 2 and a summary follows. Three variances are calculated for each of the three performance measures (fig. 2).

(1) Within-patient (or repeatability) variance

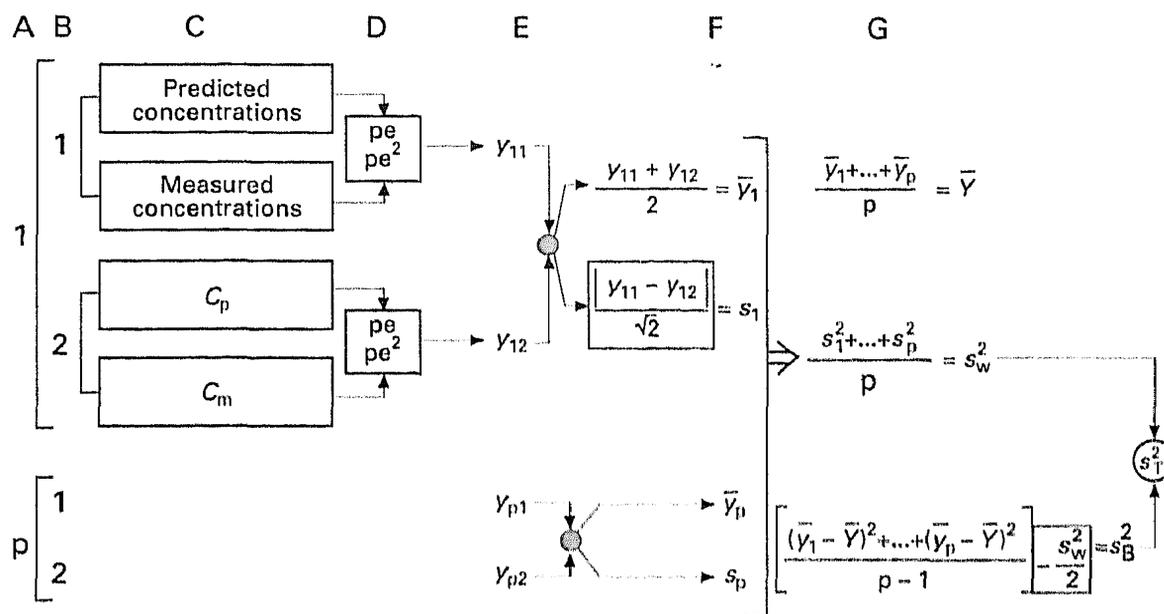

Figure 2 Flow diagram for calculating the predictive performance measures of the model (columns A-E) and their variability measures (columns F-G) from p patients: A: patient number; B: number of anaesthetics; C: predicted (C_p) and measured (C_m) end-tidal enflurane concentrations: one per 10-s period; D: prediction error (pe) (%) and squared prediction error (pe^2): one per 10-s period; E: three predictive performance measures: rmse, bias and scatter, any one of these results given by y with the appropriate subscripts for patient and anaesthetic; F: mean (\bar{y}) and standard deviation (s) of each performance measure in a patient (mathematical expressions simplified for the particular case of two observations); G: grand mean of each of the predictive performance measures (\bar{Y}), with the within-patient (s^2_w), between-patient (s^2_B) and total (s^2_T) variance.

(s^2_w) is the average of individual variances. It is an indicator of the variation in a predictive performance measure within a patient (between repeat anaesthetics). The within-patient variability can yield an estimate of an expected performance measure for an individual from other values obtained in the same patient during former anaesthetics (=repeatability).

(2) Between-patient variance (s^2_B) is an indicator of the variation in the patient means around the grand mean.

(3) Total (or reproducibility) variance (s^2_T) combines the within- and between-patient variances: it reflects the overall variation in a predictive performance measure in the sample population. The total variability observed in all patients is the variability associated with estimating one of the performance measures for a random "unexplored" patient from the grand mean (=reproducibility). In the clinical environment this is the variability encountered most frequently.

Repeatability, between-patient and reproducibility SD (SD_w , SD_B , SD_T) were also calculated for each of the performance measures.

STATISTICAL METHODOLOGY

Graphical analysis of the data preceded formal

statistical analysis. An analysis of variance was used for the predictive performance measures to calculate the components of variance according to Armitage and Berry.⁹ Multiple regression analysis was used to study the association of age, sex, body weight, body mass index ($BMI = \text{weight height}^{-2}$) and body surface area (BSA, formula of DuBois and DuBois) with the average of the two repeated performance measures obtained per patient. The criterion for rejection of the null hypothesis was $P < 0.05$ (two-sided).

Results

Initially, we studied 15 patients but data from one patient (original subject No. 10) were excluded from analysis. This patient had an extreme oculocardiac reflex during the second ophthalmic procedure requiring intervention. The clearly dissimilar clinical conditions (first vs repeat anaesthetic) yielded deviating results for rmse (8.44 vs 38.29%) and bias (3.14 vs 36.03%) although less for scatter (7.83 vs 12.95%), and precluded a meaningful analysis. Thus results of nine males and five females were analysed: mean age, body weight, BMI and BSA were 37.9 (range 14-66) yr, 71.8 (SD 10.4) kg, 22.6 (2.7) kg m^{-2} and 1.89 (0.15) m^2 , respectively. Mean

Table 2 Details of the closed-circuit conditions and predictive performance measures (mean (SD)). $n=14$ for the first and repeat anaesthetic; $n=28$ for the grand mean results (third column). Total mMAC = sum of the average measured end-tidal enflurane and nitrous oxide concentrations, expressed as multiples of MAC corrected for age⁵

	First anaesthetic	Repeat anaesthetic	First and repeat anaesthetic
No. of injections	8.1 (2.1)	7.6 (1.4)	7.9 (1.8)
Injections per hour	8.7 (2.3)	8.1 (1.0)	8.4 (1.8)
Volume of liquid enflurane (ml)	7.2 (1.0)	7.0 (1.2)	7.1 (1.1)
Volume of liquid enflurane per hour (ml)	7.7 (0.9)	7.4 (1.0)	7.5 (1.0)
Average measured end-tidal enflurane (vol%)	0.98 (0.10)	0.93 (0.14)	0.95 (0.12)
Total mMAC	1.09 (0.13)	1.06 (0.12)	1.07 (0.12)
Rmse (%)	14.63 (7.43)	15.75 (6.76)	15.19 (7.09)
Bias (%)	-1.77 (13.23)	1.65 (15.08)	-0.06 (14.10)
Scatter (%)	9.47 (3.29)	8.53 (2.09)	9.00 (2.75)

duration of closed-circuit anaesthesia was 57.5 (12.9) min. Altogether these patients provided 9654 samples of intraoperative data and they were anaesthetized with a total of 198 ml of liquid enflurane for more than 27 h. Details on the repetitive closed-circuit conditions, recorded in table 2, corroborate that the closed-circuit conditions during both anaesthetics matched well. Only minor differences in the time schedules of the enflurane bolus injections were found. Table 2 also lists the predictive performance measures obtained from the first and repeat anaesthetic, and from the pooled data. The results from the latter data were: rmse 15 (7) %, bias 0 (14) % and scatter 9 (3) % (grand mean (SD_T)).

GRAPHICAL ANALYSIS

Simple scattergrams can be used to illustrate the association between the first and repeated observation on each of the performance measures.

(1) Figure 3A (left) demonstrates good agreement between repeated observations for total error size. Visual assessment of the extent of agreement between the two results is aided by the line of identity and a zone where the repeated observations differ by no more than $\pm 5\%$. The maximum difference is approximately 11% (patient No. 12). Figure 3A (right) illustrates that the within-patient repeatability is not associated with the size of the

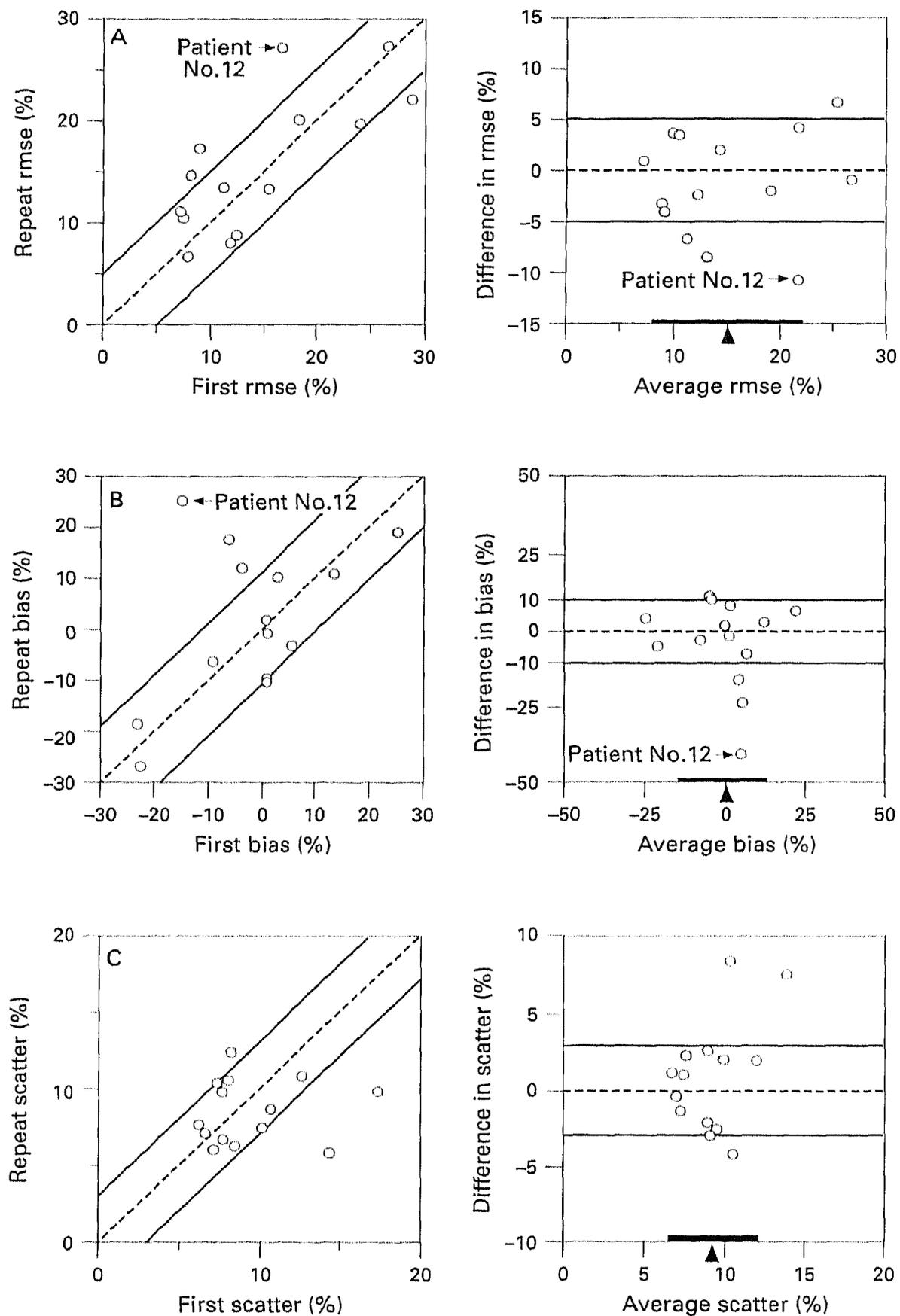

Figure 3 Left: scattergrams of the repeat *vs* first observations on each of the performance measures: A: rmse (total error budget); B: bias (systematic component of performance error); and C: scatter (error around the bias). Broken lines=lines of identity, while full lines enclose a zone where the two observations differ by no more than $\pm 5\%$ for rmse values, $\pm 11\%$ for biases and $\pm 3\%$ for scatters. Right: re-plotted data and lines from the scattergrams on the left, showing the differences between the repeated observations (first-repeat) *vs* the averages per patient for rmse values (A), biases (B) and scatters (C). \blacktriangle and the thick lines on the abscissae represent the overall results: rmse 15 (7) %, bias 0 (14) % and scatter 9 (3) % (grand mean (SD_T)).

measurements as there is no relationship between the differences in repeated observations and averaged individual rmse values.

(2) Figure 3B (left) provides the two sets of systematic errors plotted against each other. The difference between the first and repeat bias is not greater than 11% for most patients (three patients are situated out of this zone). The greatest disparity in bias between repeated observations is -15 vs 25% (patient No. 12). Again, there is no relationship between the differences in repeated observations and averaged individual biases, as depicted in figure 3B (right).

(3) Figure 3C (left and right) indicates that scatters, although showing agreement to within $\pm 3\%$ for 11 patients, are heavily dispersed in a cloud without a clear link between the repeated observations.

From the right-hand graphs in figure 3 it is apparent that the spread of observations is less in the Y -direction than in the X -direction in figure 3A (right) and, apart from patient No. 12, also in figure 3B (right) but not in figure 3C (right).

ANALYSIS OF VARIANCE

Table 3 summarizes the key results of the variability in the three predictive performance measures. For rmse, the total variance s^2_T was nearly four-fold the within-patient variance s^2_W ; thus s^2_W was much smaller than s^2_B . The ratio SD_T/SD_W was 1.98. For bias, s^2_T was twice as large as s^2_W , s^2_W was similar to s^2_B , and the ratio SD_T/SD_W was 1.39. For scatter, s^2_T was not much different from s^2_W , s^2_W was much larger than s^2_B , and the ratio SD_T/SD_W was 1.05.

Table 3 Variability in the predictive performance measures of the model obtained in 14 patients who received an enflurane anaesthetic twice. s^2_W =within-patient but between repeat anaesthetics (i.e. repeatability) variance, s^2_B =between-patient variance, s^2_T =total (i.e. reproducibility) variance, SD_W =repeatability standard deviation, SD_B =between-patient standard deviation, SD_T =reproducibility standard deviation^{7,8}

	Rmse	Bias	Scatter
Minimum (%)	6.73	-26.66	5.89
Maximum (%)	29.07	26.12	17.46
s^2_W (% ²)	12.80	102.64	6.85
s^2_B (% ²)	37.45	97.68	0.74
s^2_T (% ²)	50.24	200.32	7.59
SD_W (%)	3.58	10.13	2.62
SD_B (%)	6.12	9.88	0.86
SD_T (%)	7.09	14.10	2.75

MULTIPLE REGRESSION ANALYSIS

The average of the two repeated measurements obtained per individual, representing the best estimate of a "personal" result for each patient (e.g. a personal rmse or bias), was used to assess the potential influence of anthropometric patient characteristics on an individual's performance measures. Multiple regression analysis failed to detect a relationship between age, sex, body weight, BMI or BSA and the personal predictive performance measures.

Discussion

We have found that there was a link between the first and repeated measurement of the performance of the model. This was so for the measures rmse (total error size) and bias (systematic error), but not for scatter (fig. 3). This finding implies that most patients behaved similarly during both anaesthetics.

RATIONALE FOR A MODEL AND ITS VALIDATION

Our results are part of the necessary validation of a model. System models are used for clinical anaesthetic management, educational applications, research development, and to address economic or ecological issues. A physiological model is useful in a variety of "what happens if" scenarios, for example by predicting the effects of physiological perturbations on drug distribution.¹⁰ Such a model is based on numerous simplifying assumptions, for example average values of physicochemical data and physiological variables are used. The disposition of a drug in any subject, however, is only predictable within limits as a result of variability in pharmacokinetics and pharmacodynamics.¹¹⁻¹⁵ It is critically important to know the impact of this variability on the imprecision and reliability of model-based predictions because far-reaching conclusions can be drawn from model behaviour. The variability we wished to study was reflected in the variation in the predictive performance measures of the model.

Our overall estimates of the performance measures of the model were in accordance with those found in a former validation study.³ Standards to judge the validity of a system model for volatile anaesthetics have been defined previously.⁴ We focused on the trueness, that is the closeness of agreement between predicted and measured concentrations.^{7,16,17} A valid model should not under predict or over predict reality in a systematic way. Although it is reasonable to expect a degree of bias for each patient on each occasion, the group bias should approximate zero. This study yielded a group bias of 0 (14) % (grand mean (SD_T)). In addition, the total error size, assessed in terms of rmse, should be acceptable for most patients. Relying on biological variability in uptake found by several authors, we proposed that the total error size of a physiological model with zero group bias is acceptable if the rmse value of at least 68% of the subjects is $<30\%$.⁴ In this study rmse was $<30\%$ for the 28 analysed observations.

EXTENT OF CORRESPONDENCE

It is most unlikely that repeated observations on the same patient would give identical values for each variable (rmse, bias or scatter) in every individual. Figure 3 illustrates the percentage of subjects showing agreement to within selected numbers of units. We used zones around the lines of identity of approximately one-sixth of the full axis range, thus indicating those patients whose repeated results differed little in comparison with the total range of variability between patients. In spite of a total range

of 7–29%, the repeat rmse differed by no more than 5% from the first for 10 of 14 patients. The systematic error had a wide range (–27% to +26%), whereas the difference between the first and repeat bias was not greater than 11% for most patients. If we translate the percentage bias into vol% of end-expired concentration, a difference of less than 11% implies that the systematic errors on the two occasions differed by less than 0.11 vol% for each vol% of anaesthetic. This is a small discrepancy in clinical terms. It appears that individuals who have or have not deviated from an anticipated pharmacological behaviour on one occasion tend to behave alike on an alternate similar occasion. Subjects can deviate, even grossly, from the grand mean, yet exhibit a high level of repeatability (observations in the top right and bottom left of figure 3B) (left). Therefore, model-based predictions have an extra clinical value.

COMPONENTS OF BIOLOGICAL VARIABILITY

We estimated that, although the repeat scatters differed little for most patients (fig. 3), 90% of the total variance resulted from within-patient variance (table 3). As scatter varies much more from one anaesthetic to the next in any one patient than it does between the average scatter for different patients (fig. 3C (right)), it may be that much of this scatter is not caused by variation within the patient but by some other cause.

We estimated for rmse and bias that 75% and 49%, respectively, of the total variance was caused by between-patient variance. In contrast with scatter, the variance in rmse was mainly attributable to systematic differences between patients. For bias, variance was distributed evenly among its two components.

Comparing the results of this study with those of others is difficult because data on recurrent measurements of inhaled anaesthetics are scarce and do not include estimates of both between-patient and within-patient but between repeat anaesthetic variabilities.^{18–20} Studies in an other area of clinical research also found that prediction within patients was easier than that between patients when using a physiologically based formula, and that such information can be useful in clinical practice.²¹

ASSOCIATION WITH PATIENT CHARACTERISTICS

The high within-patient consistency was a reason for investigating the possible association of individual results for rmse or bias with age, sex, body weight, BMI or BSA. As in previous studies, a relationship between individual patient characteristics and performance measures could not be established.^{2–4} This is not surprising because these data are primary inputs to the model. It uses an individualized input to calculate some physiological variables such as cardiac output and functional residual capacity. The characteristics studied cannot be used to improve the model. Additional, yet unknown, factors may contribute in a significant extent to an individual's pharmacokinetic response. Future research may

reveal if our model-based predictions can be scaled further between individuals by other "personal" factors.

Our results ask the question whether we should save patient-related findings in a directly accessible "anaesthetic passport" (bearing the patient's anaesthetic finger printings). This may be an aid to anaesthetists in the future.²² They may plan the anaesthetic of their patients on the basis of the average behaviour of a standard human, perhaps also according to institutional algorithms. Subsequently they may adapt the anaesthetic drug administration to tailor the anaesthetic to the physiological status of their patient. Models can facilitate these processes of decision making. But anaesthetists are also interested in identifying those patients who are likely to deviate from anticipated average behaviour. Our results suggest that determination of bias (or rmse) in a patient on one occasion, even if that bias is large, may be a useful predictor of bias on subsequent occasions. This is well illustrated in figure 3B (left), apart from patient No. 12. Other authors have shown that the correlation of anaesthetic uptake with easily observable patient characteristics is poor.^{18,23} If the patient must receive another anaesthetic, the judicious use of data identified during a former anaesthetic may be the best basis available to adjust the "rules of thumb" which anaesthetists use when managing a patient.²⁴

RESERVATIONS

The data showing high repeatability were gathered under similar clinical conditions. Therefore, repeatability values should not be extrapolated to apparently different conditions. Model-based drug regimens and algorithms are not intended as rigid recipes.¹⁸ They offer a reasonable approach to anaesthetic management that must be individualized with the aid of clinical observations and vigilant monitoring of end-tidal concentrations and haemodynamic variables.²⁵

A few patients with poor consistency and one outlier were found. Their presence suggests that the use of an adaptive model or feedback-controlled anaesthesia is worth considering for future development.^{23,26,27} The control algorithms needed can be developed initially with the aid of a model which should be well validated and exhibit a realistic amount of variability such as that found in the present study.

We believe that repeatability data should be available to each research group studying the predictive performance of models, not only because it is important to separate within-patient from overall variability, but also because poor repeatability may highlight the need to re-examine the various procedures involved in gathering the data.²⁸

In this era of multi-gas monitoring techniques and impending automated administration of volatile anaesthetics, there is still a definite role for well validated models of human physiology and pharmacology. The results for overall variability show that a dosing regimen based on our model is a useful starting strategy for administering closed-circuit

inhalation anaesthesia; the results for within-patient variability suggest that a patient may benefit from using a starting regimen corrected from the findings obtained during a former anaesthetic.

Appendix 1

A concise non-mathematical account of the model is presented here. A comprehensive quantification and mathematical formulation have been presented elsewhere.¹ Our physiological model depicts the body and closed anaesthetic circuit as a system of 14 compartments (fig. 4). A liquid anaesthetic agent injected directly into the closed system is assumed to mix uniformly after vaporization with the contents of the closed breathing system. The anaesthetic agent is taken up from the alveolar space and distributed to the other tissue compartments: heart, brain, kidneys, liver (including all other well-perfused organs), muscles, connective tissue and adipose tissue. The model derives from the subject's age, sex, body weight and height, the other physiological variables, including deadspace, alveolar space, blood volume, cardiac output and tissue volumes.

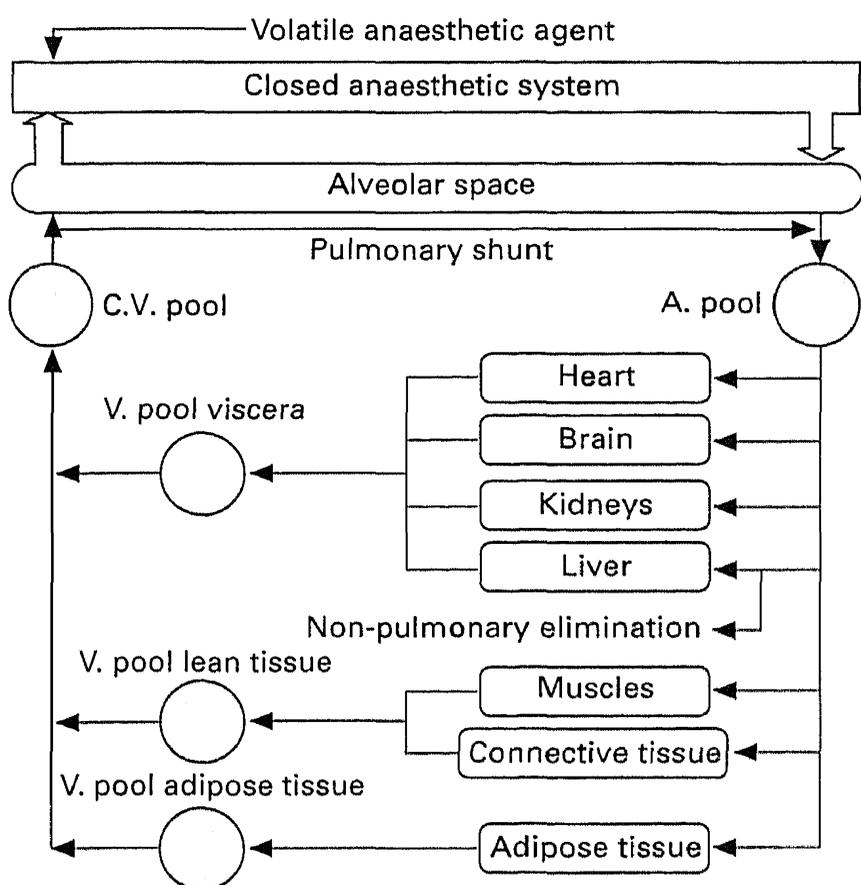

Figure 4 Simplified schematic diagram of the 14-compartment physiological model which includes the closed anaesthetic circuit and the patient tissues; the circles represent the blood pools (A.=arterial; (C.) V.= (central) venous).

Our system model differs from previous models for closed-circuit anaesthesia in four main ways. (1) Unlike the model of Lowe and Ernst it does not assume that the arterial concentration remains constant.²⁹ This implies that the model is able to predict breath-by-breath end-expired concentrations after bolus injections of a liquid anaesthetic agent into the closed system. (2) Our model does not assume that either the circulating times are zero or that venous blood is part of each tissue compartment. Rather we followed Mapleson's suggestions by introducing his concept of blood pools that mimics circulation times in the body.³⁰ (3) The model incorporates a non-pulmonary route of elimination for enflurane and halothane.³⁴ (4) Age-related blood-gas and tissue-blood partition coefficients can be introduced. For halothane we showed that this improved the accuracy of the model.⁴

Appendix 2

Suppose we have p patients called i ($i=1, 2, \dots, p$) with m repeated observations on the same patient, giving a total of pm results for each of the three performance measures. If any one of

these results is y_{ik} ($k=1, 2, \dots, m$), then the individual mean result for patient i is:

$$\bar{y}_i = \frac{1}{m} \sum_{k=1}^m y_{ik}$$

The individual SD, that is a measure of the dispersion of the m repeated observations on the same subject, is given as:

$$s_i = \sqrt{\frac{1}{m-1} \sum_{k=1}^m (y_{ik} - \bar{y}_i)^2}$$

The grand mean for the sample population is:

$$\bar{Y} = \frac{1}{p} \sum_{i=1}^p \bar{y}_i$$

Three variances are calculated for each of the performance measures.

(1) Within-patient (or repeatability) variance s^2_w is the average of individual variances:

$$s^2_w = \frac{1}{p} \sum_{i=1}^p s_i^2$$

(2) Between-patient variance s^2_B is an indicator of the variation in expected means between patients; this estimate is based on the distribution of patient means:

$$s^2_B = \frac{1}{p-1} \sum_{i=1}^p (\bar{y}_i - \bar{Y})^2 - \frac{s^2_w}{m}$$

(3) Total sample population (or reproducibility) variance s^2_T combines within- and between-patient variances:

$$s^2_T = s^2_w + s^2_B$$

The repeatability and reproducibility SD values are given by $SD_w = \sqrt{s^2_w}$ and $SD_T = \sqrt{s^2_T}$, respectively.

Acknowledgements

We thank M. A. van 't Hof, PhD, statistician (Department of Medical Statistics, University of Nijmegen) for statistical advice, and M. C. J. De Ruiter, BSc, for technical assistance.

References

1. Lerou JGC, Dirksen R, Beneken Kolmer HH, Booij LHDJ. A system model for closed-circuit inhalation anaesthesia: I. Computer study. *Anesthesiology* 1991; 75: 345-355.
2. Lerou JGC, Dirksen R, Beneken Kolmer HH, Booij LHDJ, Borm GF. A system model for closed-circuit inhalation anaesthesia: II. Clinical validation. *Anesthesiology* 1991; 75: 230-237.
3. Lerou JGC, Vermeulen PM, Dirksen R, Booij LHDJ, Borm GF. The predictive performance of a system model for enflurane closed-circuit inhalational anaesthesia. *Anesthesiology* 1993; 79: 932-942.
4. Vermeulen PM, Lerou JGC, Dirksen R, Booij LHDJ, Borm GF. A system model for halothane closed-circuit anaesthesia: structure considerations and performance evaluation. *Anesthesiology* 1995; 83: 515-527.
5. Mapleson WW. Effect of age on MAC in humans: a meta-analysis. *British Journal of Anaesthesia* 1996; 76: 179-185.
6. Gravenstein N, Banner MJ, McLaughlin G. Tidal volume changes due to the interaction of anaesthesia machine and anaesthesia ventilator. *Journal of Clinical Monitoring* 1987; 3: 187-190.
7. International Organization for Standardization, ISO 5725-1: 1994, Accuracy (Trueness and Precision) of Measurement Methods and Results—Part 1: General Principles and Definitions. Geneva: International Organization for Standardization, 1994; 1-17.
8. International Organization for Standardization, ISO 5725-2: 1994, Accuracy (Trueness and Precision) of Measurement Methods and Results—Part 2: Basic Method for the Determination of Repeatability and Reproducibility of a Standard Measurement Method. Geneva: International Organization for Standardization, 1994; 1-42.
9. Armitage P, Berry G. *Statistical Methods in Medical Research*, 3rd Edn. Oxford: Blackwell Science, 1994; 219-223.

10. Davis NR, Mapleson WW. A physiological model for the distribution of injected agents, with special reference to pethidine. *British Journal of Anaesthesia* 1993; 70: 248–258.
11. Hull CJ. Variation in drug disposition I: The influence of age, sex and heredity. In: Hull CJ, ed. *Pharmacokinetics for Anaesthesia*. Oxford: Butterworth-Heinemann, 1991; 111–125.
12. Hull CJ. Variation in drug disposition II: Pregnancy, disease, drugs and anaesthesia. In: Hull CJ, ed. *Pharmacokinetics for Anaesthesia*. Oxford: Butterworth-Heinemann, 1991; 126–142.
13. Vesell ES. Genetic and environmental factors affecting drug disposition in man. *Clinical Pharmacology and Therapeutics* 1977; 22: 659–679.
14. Matzke GR, St Peter WL. Clinical pharmacokinetics 1990. *Clinical Pharmacokinetics* 1990; 18: 1–19.
15. Wood M. Anesthesia, pharmacokinetics, and variability of human drug response. In: Barash PG, ed. *ASA Refresher Courses in Anesthesiology*. Philadelphia: JB Lippincott, 1992; 223–234.
16. Chatburn RL. Fundamentals of metrology: evaluation of instrument error and method agreement. In: Kacmarek RM, Hess D, Stoller JK, eds. *Monitoring in Respiratory Care*. St Louis: Mosby-Year Book, 1993; 97–144.
17. International Organization for Standardization, ISO 3534-1: 1993, *Statistics—Vocabulary and Symbols—Part 1: Probability and General Statistical Terms*. Geneva: International Organization for Standardization, 1993; 1–15.
18. Westenskow DR, Jordan WS, Hayes JK. Uptake of enflurane: A study of the variability between patients. *British Journal of Anaesthesia* 1983; 55: 595–600.
19. Norgate CE, Sharp JH, Cousins MJ. Metabolism of enflurane in man following a second exposure. *Anaesthesia and Intensive Care* 1976; 4: 186–191.
20. Schwilden H, Tonner PH, Röpcke H. Voraussagbarkeit in- und endexpiratorischer Isofluran- und Enflurankonzentrationen durch pharmakokinetische Modelle und interindividuelle Variabilität. *Anästhesie Intensivtherapie und Notfallmedizin* 1990; 25: 317–321.
21. Hope DA, Jenkins BJ, Willis N, Maddock H, Mapleson WW. Non-invasive estimation of venous admixture: validation of a new formula. *British Journal of Anaesthesia* 1995; 74: 538–543.
22. Ty Smith N, Edsall DW. The computer-based patient record for anaesthesia. In: Prys-Roberts C, Brown BR jr, eds. *International Practice of Anaesthesia*. Oxford: Butterworth-Heinemann, 1996; 1–18.
23. O'Callaghan AC, Hawes DW, Ross JAS, White DC, Wloch RT. Uptake of isoflurane during clinical anaesthesia: Servo-control of liquid anaesthetic injection into a closed-circuit breathing system. *British Journal of Anaesthesia* 1983; 55: 1061–1064.
24. Asbury AJ, Tzabar Y. Fuzzy logic: new ways of thinking for anaesthesia. *British Journal of Anaesthesia* 1995; 75: 1–2.
25. Sear JW, Glen JB. Propofol administered by a manual infusion regimen. *British Journal of Anaesthesia* 1995; 74: 362–367.
26. Ross JAS, Wloch RT, White DC, Hawes DW. Servo-controlled closed-circuit anaesthesia: A method for the automatic control of anaesthesia produced by a volatile agent in oxygen. *British Journal of Anaesthesia* 1983; 55: 1053–1059.
27. Morris P, Tatnall ML, Montgomery FJ. Controlled anaesthesia: a clinical evaluation of an approach using patient characteristics identified during uptake. *British Journal of Anaesthesia* 1983; 55: 1065–1075.
28. Lawrence GP, Home PD, Murray A. Repeatability of measurements and sources of variability in tests of cardiovascular autonomic function. *British Heart Journal* 1992; 68: 205–211.
29. Lowe HJ, Ernst EA. *The Quantitative Practice of Anesthesia*. Baltimore: Williams and Wilkins, 1981.
30. Mapleson WW. Circulation-time models of the uptake of inhaled anaesthetics and data for quantifying them. *British Journal of Anaesthesia* 1973; 45: 319–334.