



City Research Online

City, University of London Institutional Repository

Citation: Panchal, J. P., McNamara, A. M. ORCID: 0000-0002-3452-0800 and Goodey, R.J. ORCID: 0000-0002-9166-8393 (2018). Influence of geometry on the bearing capacity of sheet piled foundations. In: McNamara, A. M. ORCID: 0000-0002-3452-0800, Divall, S. ORCID: 0000-0001-9212-5115, Goodey, R.J. ORCID: 0000-0002-9166-8393, Taylor, N, Stallebrass, S. E. ORCID: 0000-0002-3747-9524 and Panchal, J. P. (Eds.), Physical Modelling in Geotechnics: Proceedings of the 9th International Conference on Physical Modelling in Geotechnics (ICPMG 2018), July 17-20, 2018, London, United Kingdom. (pp. 1395-1400). Boca Raton: CRC Press/Balkema. ISBN 9781138344228

This is the accepted version of the paper.

This version of the publication may differ from the final published version.

Permanent repository link: <http://openaccess.city.ac.uk/id/eprint/20299/>

Link to published version:

Copyright and reuse: City Research Online aims to make research outputs of City, University of London available to a wider audience. Copyright and Moral Rights remain with the author(s) and/or copyright holders. URLs from City Research Online may be freely distributed and linked to.

Influence of geometry on the bearing capacity of sheet piled foundations

J.P. Panchal, A.M. McNamara & R.J. Goodey

Research Centre for Multi-Scale Geotechnical Engineering, City, University of London, United Kingdom

ABSTRACT: Bored concrete piles are commonly used to support moderate loads from buildings in urban areas. At the end of their 25-30 year lifespan these structures are decommissioned but their foundations are left in place. These cannot be inspected hence the bearing capacity cannot be accurately verified. A hybrid foundation comprising sheet piles and a pilecap to mobilise shaft friction and end bearing was demonstrated to be a feasible and sustainable alternative to cast in-situ concrete piles. This research investigated the influence of sheet pile geometry on ultimate bearing capacity. A centrifuge test at 50g was performed in over-consolidated clay where a square hybrid sheet pile group was axially loaded and vertical settlements recorded. Results indicated a square sheet pile group offers 70% greater capacity than a circular sheet pile group of similar surface area and 24% improved performance over the solid pile loaded in the same test. Analysis of results suggested that the ultimate bearing capacity of the square sheet pile group compared with a solid pile of equivalent base area were within 0.2%, emphasising the importance of shape on capacity and the feasibility of the hybrid system as a viable foundation solution.

1 INTRODUCTION

Bored piles are a common foundation type for moderately loaded structures and recent calls have been made to extend piling applications to low rise residential projects (Ground Engineering, 2018). Concrete piles comprise a significant volume of concrete and are rarely removed during demolition. These piles consequently cause obstructions to future developments and must be removed or avoided which can have large financial impact on a project and result in programme delays.

Significant efforts have been made to increase foundation solution sustainability, including the recent development and trialling of hollow piles (McNamara et al. 2014) which benefit from a significantly reduced volume of concrete.

CIRIA C653 (2007) recommends the reuse of existing piles, however it acknowledges that uncertainties remain in establishing pile integrity and reliability owing to difficulties in inspection.

Smaller diameter piles generate greater capacity from less concrete. However, the issue of breaking out, transporting and crushing concrete still remains before it can be recycled. A more sustainable solution may exist by use of sheet piles, which can be extracted following superstructure demolition. Their condition can be assessed on site and they can be re-

used immediately, saving time and eliminating muck away.

2 BACKGROUND

Previous centrifuge modelling studies were conducted (Panchal et al., 2016) with a sheet pile group arranged in circular formation. The diameter of the foundation at the neutral axis of the sheet pile group was 60mm. The sheet pile shaft protruded above ground level and a resin pile cap was cast within the area enclosed by the sheet pile group. 5mm holes had been drilled along each sheet pile shaft at 30mm centres with the aim of increasing frictional resistance.

Smooth and rough solid circular shafted model piles, 60mm in diameter, were also tested to provide comparisons against the sheet pile foundations. The aim of this was to determine whether the hybrid pile system was a credible foundation solution offering comparable or improved bearing capacity over conventional solid piles.

Results, see Figure 1, indicated that the sheet pile group with cap arrangement offered a 22% increase in bearing capacity compared with the smooth shafted pile and only 12% lower capacity than a rough pile. This validated the idea that this hybrid pile arrangement was a reasonable alternative to conven-

tional straight-shafted concrete piles with scope for further development.

One concern associated with this piling method however would be the contractor's ability to drive sheet piles in a circular arrangement on site, whilst maintaining verticality and interlock between sections. An alternative sheet pile arrangement was sought in order to evaluate the influence of the pile group shape on bearing capacity.

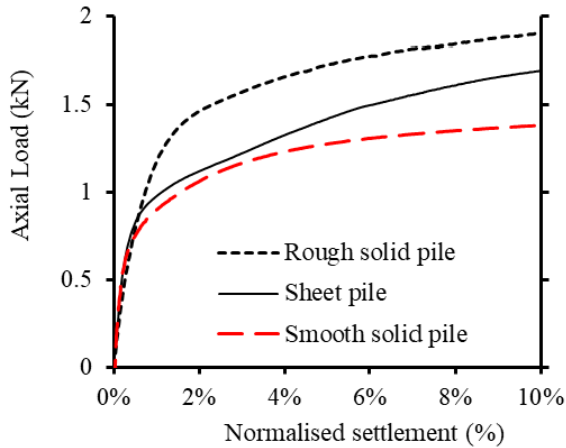

Figure 1. Centrifuge test results by Panchal et al. (2016)

3 OBJECTIVES

This study aimed to determine the influence of sheet pile group shape on the ultimate bearing capacity.

An additional centrifuge test at 50g was conducted to compliment earlier published literature (Panchal et al., 2016). This experiment focussed on modelling a comparable cross sectional area but varying the pile configuration in plan.

In designing a more buildable sheet pile formation the shaft area was inevitably altered. The purpose of this was to establish whether any change in ultimate bearing capacity was observed for an open ended capped sheet pile. In addition, an assessment was to be made to determine whether the end bearing or shaft friction was more critical in improving the capacity of a hybrid pile.

4 SOIL MODEL

Centrifuge experiments were conducted in a 300mm deep 420mm diameter steel cylindrical centrifuge tub. The final sample was required to be flush with the top of the tub which was achieved by bolting on a 300mm deep cylindrical extension.

The walls of the tub were lubricated with water pump grease and a layer of porous plastic and filter paper were placed at the base. Herringbone channels cut into the base of the tub directed water towards two drainage taps.

Speswhite kaolin powder was mixed with distilled water to a water content of 120%, which is approximately twice its liquid limit. An industrial ribbon blade mixer was used to produce a uniform slurry. Slurry was carefully placed in the tub by means of a scoop whilst a palette knife was used to agitate the clay between each pour to prevent the entrapment of air. It was placed to a depth of approximately 550mm before being sandwiched between another layer of porous plastic and filter paper.

The package was transferred to a hydraulic press where a loading platen, attached to a ram was lowered onto the sample. Pipes were connected to the drainage taps of the centrifuge tub and directed to a bucket. Holes drilled in the top of the platen also allowed water to seep up as the sample was loaded, halving the drainage path length and accelerating the rate of consolidation. A reasonably stiff sample was achieved by gradually increasing the pressure on the sample from 20kPa to 500kPa over a period of a week before swelling it back to 250kPa the day prior to testing. This produced a sample that protruded above the top of the centrifuge tub.

5 APPARATUS AND EQUIPMENT

The loading apparatus used in this experiment was designed and manufactured by Gorasia (2013) and is illustrated in Figure 2. It comprised a frame that bolted above the centrifuge tub and housed a lead screw actuator. A loading beam was connected to the actuator and could accommodate two load cells at each end and a number of LVDTs.

A rough solid circular shafted pile consisted of a 48mmOD aluminium tube which was closed at the base and positioned in a 60mm diameter open bore, the annulus of which was filled with resin during model making. Two 60mm long rods had been drilled through the pile perpendicular to its length and served the purpose of centralising the pile in the bore before the resin was placed. A 10mm thick 20mm diameter Perspex spacer was glued to the base of the pile which also permitted resin to coat the base of the pile, see details in Figure 3.

The sheet pile foundation was fabricated from a single 0.5mm thick stainless steel sheet that had been repeatedly pressed to form each rib. The sheet was then folded to form a square section with a perimeter of 246mm. The sheet had been sandblasted to produce a suitably rough surface. Characteristics of all piles analysed in this paper are summarised in Table 1 at model scale.

An aluminium square loading cap sat on the sheet pile and the underside had been machined to provide a lip in which the sheet pile could sit, see Figure 4. A loading cap rested on the pilecap on which the load cell and LVDTs were seated.

Table 1. Model pile characteristics (all piles 180mm long)

Pile type	Nominal diameter or length (mm)	Pile shaft perimeter (mm)	Pile base area (mm ²)
Rough solid	60	188	2827
Circular sheet	60	217	2827
Square sheet	50	246	3782

Comparisons of pile characteristics

Square sheet vs rough solid pile	31%	34%
Circular sheet vs rough solid pile	15%	0%
Square sheet vs circular sheet pile	13%	34%

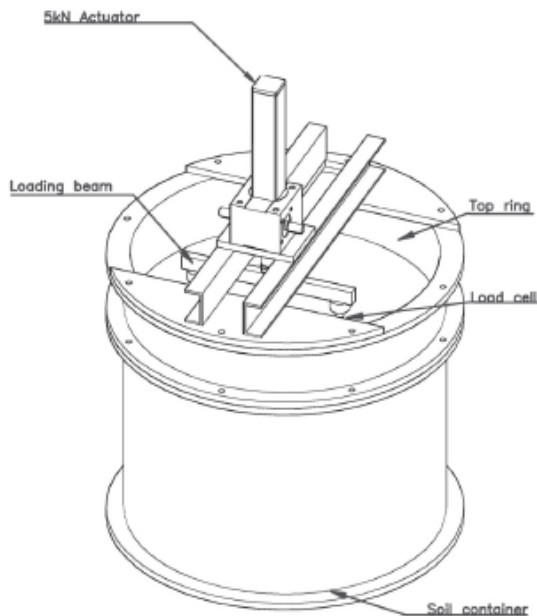

Figure 2. Centrifuge loading frame (Gorasia, 2013)

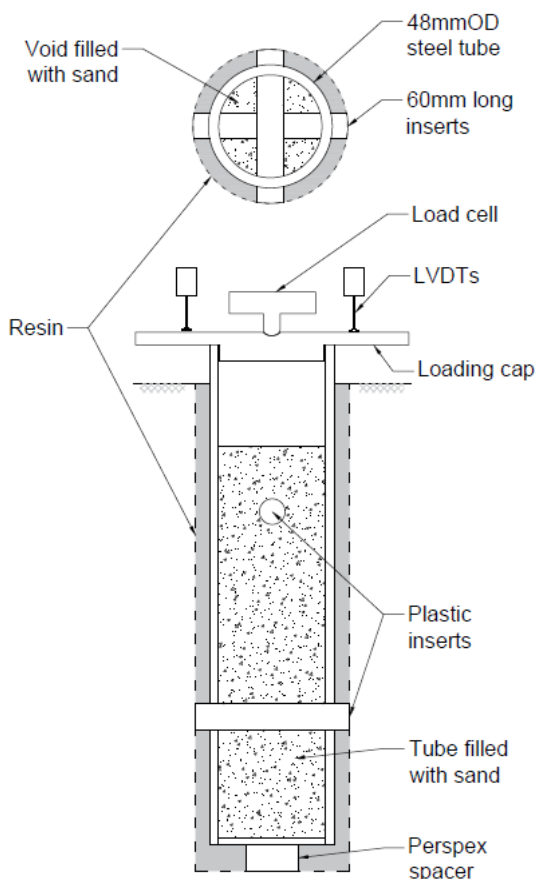

Figure 3. Rough solid circular pile arrangement (Panchal et al., 2016)

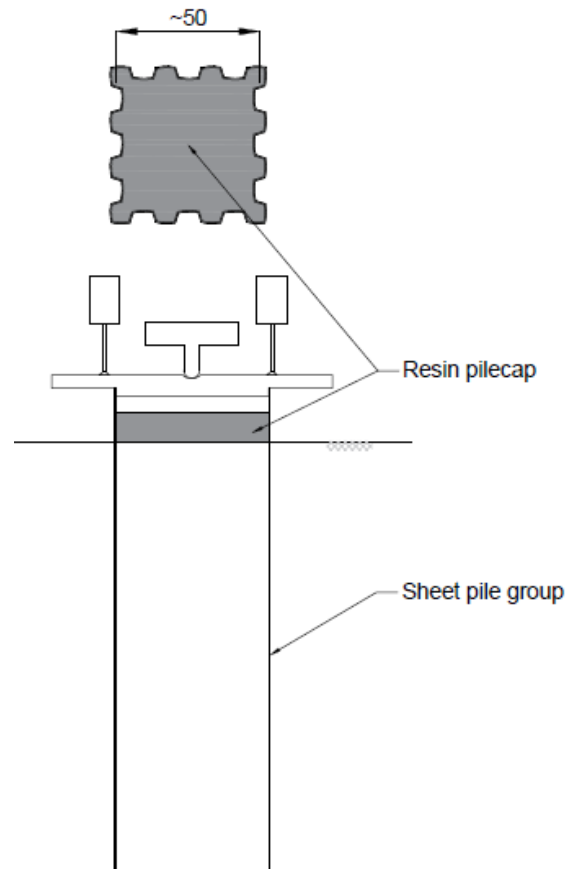

Figure 4. Square sheet pile with pilecap and loading cap arrangement

6 TESTING PROCEDURE

The centrifuge model was prepared at 1g. Firstly, the tub was removed from the hydraulic press and the extension unbolted. The sample was trimmed using a wire cutter and palette knife until it was level with the top of the tub, giving a 300mm deep sample. PlastiDip (an aerosol applied synthetic rubber membrane) was sprayed across the surface of the clay to prevent it from drying out during model making and when in-flight.

The loading frame was then placed on the tub and the beam lowered until the load cells indented the soil surface to mark out the centres of the piles. The square sheet pile was aligned such that the centre was approximately aligned with the indent and the hydraulic press embedded the sheet pile in a carefully controlled manner to a depth of 180mm.

A pair of dividers was used to mark out the circumference of the pile before using a thin walled cutter and guide to form the 180mm deep 60mm diameter bore. The base of the bore was scraped and care was taken when placing the 48mm OD hollow tube in the bore to ensure that the 60mm plastic inserts did not scrape the edges of the bore. Sand was poured in the tube so that the final weight of the cast in-situ pile was equal to the weight of soil removed. This was necessary to prevent the pile from becoming buoyant during consolidation.

Two-part epoxy resin was thoroughly mixed before being carefully poured around the sides of the open bore to the top of the clay surface. Resin also formed the pilecap of the sheet pile and was contained within the sheet upstand, see Figure 5. Once the resin had cured the loading caps were placed on each of the piles before securing the loading frame to the centrifuge tub. The LVDTs were secured in position and rested on the loading cap plates. A bead of silicone grease was applied around the edge of the model to prevent it from drying out in-flight. The package was weighed and transferred to the centrifuge in preparation for testing.

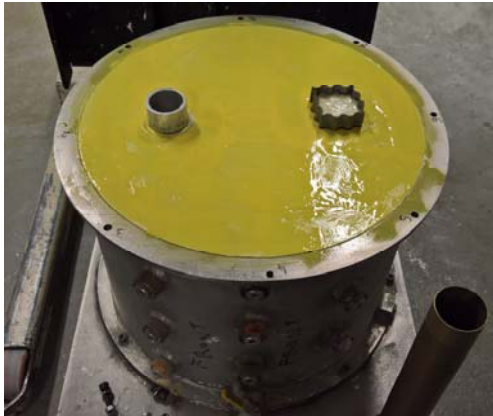

Figure 5. Sealed sample with piles and resin cast in-place prior to securing the loading frame.

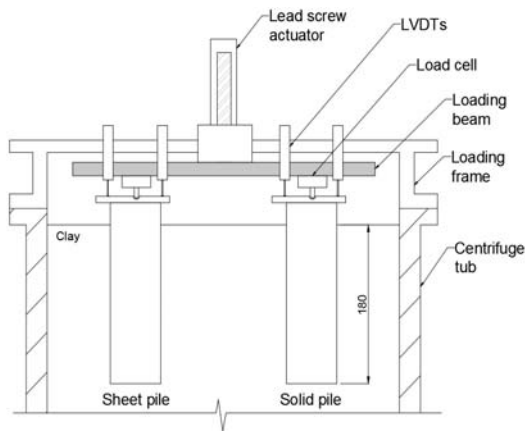

Figure 6. Cross section through centrifuge tub illustrating location of piles and instrumentation (Panchal et al., 2016)

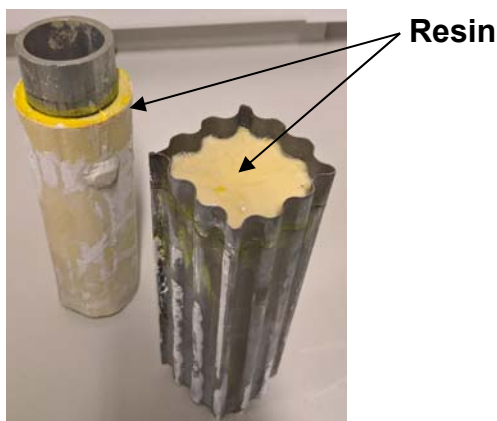

Figure 7. Recovered solid circular and sheet piles post-test

A standpipe was connected to establish a water table 30mm below the surface of the clay. It was intended that the sample would be left to consolidate at 50g overnight to allow excess pore pressures to dissipate, however problems with the centrifuge apparatus meant that the test was conducted immediately upon reaching 50g and a water table was not established.

Testing of the model involved loading the piles at a rate of 1mm/minute to simulate an undrained loading event until settlement equivalent to 10% of the pile diameter was achieved. Figure 6 provides a schematic of the model and testing apparatus. Following the test, shear vane readings were taken and the piles were recovered (Figure 7).

7 TEST RESULTS

One centrifuge test was carried out as part of this study to compliment findings from Panchal et al. (2016). The centrifuge tub was sufficiently large to test two piles and avoid boundary effects.

A rough circular solid pile was tested alongside a square sheet pile with a resin pile cap. This permitted a means of comparing and analysing the bearing capacity of each pile in the same soil sample.

The results from this test have been plotted in Figure 8. A greater bearing capacity of 25% was achieved by the square sheet pile group in comparison to a rough circular solid pile, which was expected as the square sheet pile group was 31% larger in perimeter and 34% greater in base area.

However, results published by Panchal et al., (2016) showed that although the circular sheet pile group was 15% larger in perimeter than a solid circular pile it reduced the ultimate capacity by 12%. This suggests that a relatively smooth circular sheet pile group does not offer significant benefits over a conventional circular bored concrete pile.

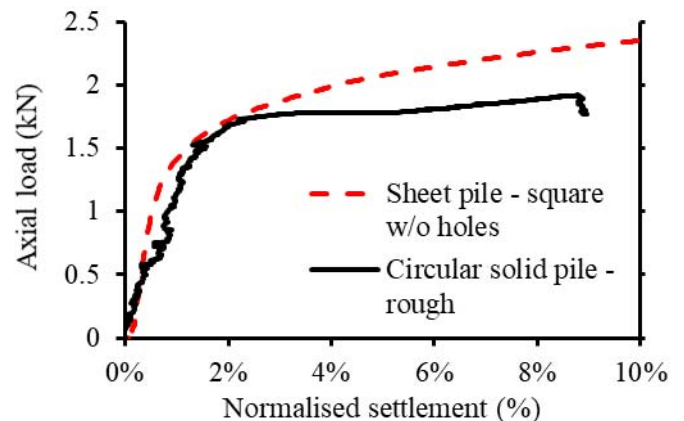

Figure 8. Results from current centrifuge test on a rough solid circular pile and a square sheet pile

8 ANALYSIS OF RESULTS

Establishing whether any structural benefit existed in altering the shape of the sheet piled foundation relied on results from previous experiments. Published results (Panchal et al., 2016) of a rough solid pile and circular sheet pile group were compared against the measurements taken from this experiment. This provided a wide range of results, summarised in Table 2, from which observations were drawn. $Q_{(ult)}$ is defined as the ultimate pile bearing capacity at 10% settlement.

Table 2. Summary of tests used in analysis

Test	Pile type		$Q_{(ult)}$ (kN)
1 (Panchal et al., 2016)	Solid	Rough	1.90
2	Sheet	Circular with holes	1.69
3	Sheet	Circular without holes	1.17
3	Solid	Rough	1.91
3	Sheet	Square without holes	2.37

Results from all experiments were plotted in Figure 9. Although in the most recent test the model was not left to consolidate overnight, it was observed that the ultimate bearing capacities of the rough solid piles were comparable. Shear vane readings were also consistent between tests. This highlighted the reliability and consistency between tests and permits comparisons to be made between the circular and square sheet piled foundations.

Two variations of circular sheet piled foundations were previously investigated; with and without 5mm holes drilled at 30mm centres along the ribs. The results from both scenarios were also plotted on Figure 9 and the capacity of a sheet pile with holes was approximately 1.4-1.5 times greater throughout the duration of the test. This trend was applied to the square sheet pile group and the loads were multiplied by 1.45 to estimate the response of a square sheet pile with holes as illustrated by the dashed black line in Figure 9.

The ultimate bearing capacity ($Q_{(ult)}$) is a summation of the base capacity (Q_b) and shaft friction (Q_s) and is calculated using Equations (1) to (3).

$$Q_{(ult)} = Q_b + Q_s \quad (1)$$

$$Q_s = EA_s S_u \alpha \quad (2)$$

$$Q_b = EA_b (N_c S_u + \gamma H) \quad (3)$$

Where EA is the external area; S_u the undrained shear strength; α the adhesion factor; N_c the dimensionless factor governed by pile diameter and depth; L the pile length and γ the soil bulk unit weight.

Owing to the geometry of the piles in these tests, N_c equated to 9. The sheet piled foundations were analysed as open ended tubular piles and following the ICP design methods (Jardine et al., 2005), Q_b

was reduced by half to account for the plugging effect at the base of the pile.

The adhesion factors (α) were back analysed from the difference between the ultimate capacity measurement and base capacity calculation and are given in Table 3 and show a reasonable range of values (Bell & Robinson, 2012).

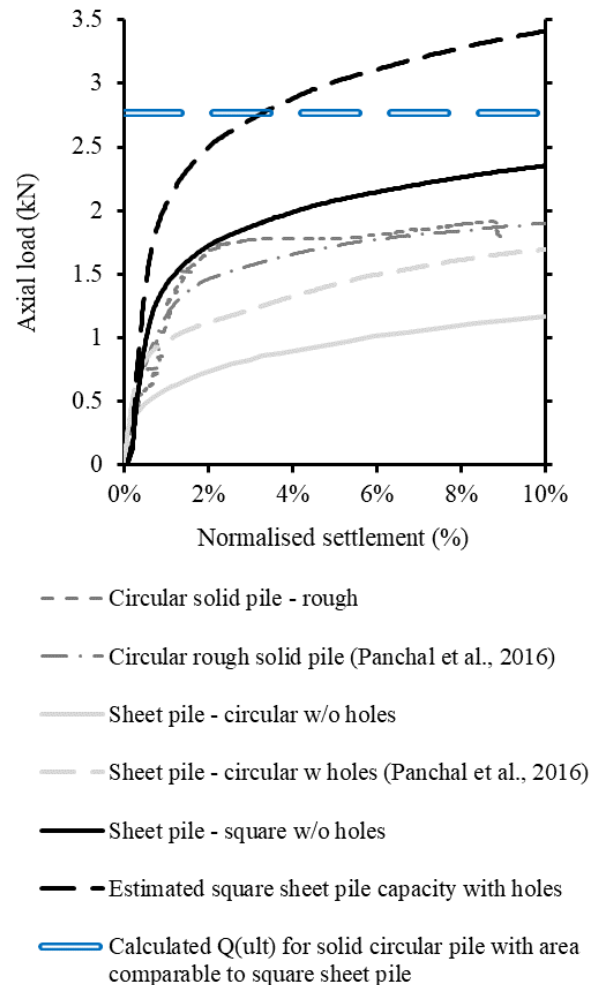

Figure 9. Results from current and previous centrifuge tests

Table 3. Alpha values back analysed from centrifuge tests

Test	Pile type		α values
1	Solid	Rough	0.522
2	Sheet	Circular with holes	0.359
2	Sheet	Circular without holes	0.304
3	Solid	Rough	0.597
3	Sheet	Square without holes	0.559

It is worth noting that the α value for the square sheet pile group was considerably higher than the values obtained for the circular piles. This was likely to have occurred owing to the square sheet pile group having a larger surface area than the solid shafted and circular sheet piles. In addition, the ribs on the square sheet pile group are less open than those of the circular sheet pile group. The ribs may have become plugged with soil hence loading the pile would mobilise a higher proportion of the soil strength as it sheared against the soil/steel and soil/soil interfaces, as illustrated in Figure 10.

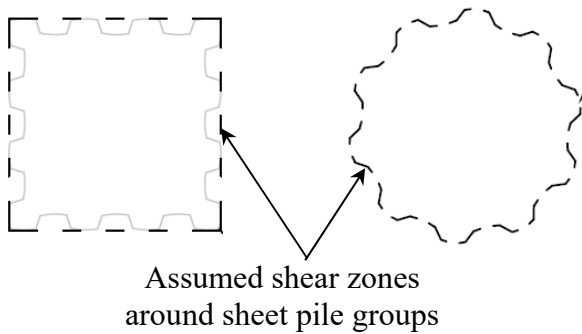

Figure 10. Assumed shear zone around square sheet piles

To assess the performance of a square sheet pile group against a solid circular shafted rough pile of comparable size it was necessary to scale up the geometry of the rough pile used in this most recent test. The base area equalled that of the square sheet pile and α was taken as 0.597, as indicated in Table 3. Q_{ult} was calculated as 2.77kN which is 17% greater than the measured response of the square sheet pile. However, assuming that holes drilled through the sheet pile shaft increases the ultimate capacity to would offer an improved bearing capacity of 23% over the conventional concrete bored pile.

An assessment of the boundary effects was necessary to determine the validity of the results from these experiments. The stress bulb that forms below a shallow foundation is assumed to be equal to $2B$ (Boussinesq, 1885). In this model the piles were nominally 60mm diameter (B) and 180mm long in a 300mm deep soil sample. This provided 120mm clearance and satisfied the $2B$ end bearing boundary effects criteria.

Ullah et al. (2016) investigated the lateral boundary effects of modelling foundations in the centrifuge. Figure 11 maps the criteria for eliminating or reducing the boundary effects of a foundation in the model. The minimum recommended L/D dimension is 1.5 in a uniform clay sample and any value greater than 2 indicates that no boundary effects exist. In these experiments L/B was 1.75 and within the potential boundary effect zone. Although this may have had some influence on the results, consistency of boundary effects was achieved across tests owing to similarities in the experiment and apparatus set up.

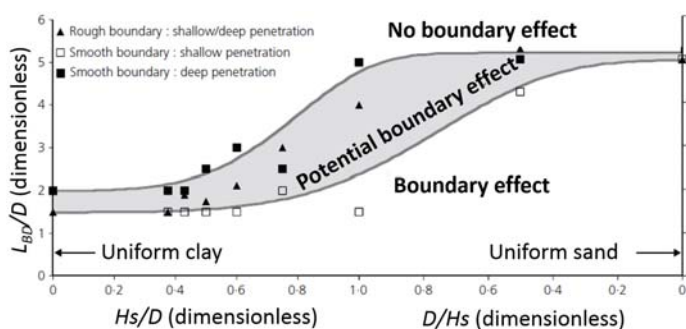

Figure 11. Boundary effects zones in centrifuge tests (Ullah et al., 2016)

9 CONCLUSION

One centrifuge test at 50g was conducted to measure the response of a rough solid circular pile and a sheet pile foundation in a square formation with a resin pilecap.

The results from this experiment were compared with those published in the literature (Panchal et al., 2016) to understand the influence of the foundation shape on its performance.

Results showed that the square sheet pile group achieved a 25% greater bearing capacity than the solid circular pile tested in this experiment. Analysis of these results showed that for a comparable pile base area similar capacities would be obtained.

The perimeter of the square sheet pile group was only 13% greater than the circular sheet pile group and this scenario offered a 40% increase in bearing capacity over an alternative sheet pile arrangement.

This investigation suggests that a square sheet pile group is a viable alternative to solid concrete piles and offers huge economic and sustainability benefits in pile construction, removal and reuse.

REFERENCES

- Bell A. and Robinson C. 2012. Chapter 54 Single piles. ICE manual of geotechnical engineering: Volume II. January 2012, pp803-821.
- Boussinesq, M. J. 1885. Application des potentiels a l'etude de l'equilibre et du mouvement des solides elastiques, principalement au calcul des deformations et des pressions que produisent, dans ces solides, des efforts quelconques exercees sur une petite partie de leur surface ou de leur interieur: Memoire suivi de notes etendues sur divers points de physique mathematique et d'analyse. GauthierVillars, Paris, pp722.
- CIRIA 2007. C653: Reuse of Foundations. CIRIA, London.
- Gorasia, R.J. 2013. Behaviour of ribbed piles in clay. PhD thesis, Research Centre in Multi-scale Geotechnical Engineering, City University London, UK.
- Ground Engineering 2018. Call for end to strip foundations for housing, Ground Engineering Magazine, <http://digitalissues.geplus.co.uk/GE/2018/JanFeb/index.html>, pp7.
- Jardine, R., Chow, F., Overy, R. and Standing, J. 2005. 4 Design Methods for Piles in Clay. ICP design methods for driven piles in sands and clays. January 2005, Thomas Telford, London, pp28-37.
- McNamara, A.M., Suckling, T.P., McKinley, B. and Stallebrass, S. 2014. A field trial of a reusable, hollow, cast-in-situ pile. Proceedings of the Institution of Civil Engineers - Geotechnical Engineering 2014, Volume 167, Issue 4, pp390-401.
- Panchal, J., McNamara, A. and Goodey, R. 2016. Bearing capacity of sheet piled foundations. Proceedings of the 2nd Asian Conference on Physical Modelling in Geotechnics. Asiafuge 2016 (ed. Ma, X.), Tongji University, Shanghai, China, pp1-6.
- Ullah, S.N., Hu, X., Stanier, S. and White D. 2016. Lateral boundary effects in centrifuge foundation tests. International Journal of Physical Modelling in Geotechnics, Volume 17(3), pp144-160.