



WestminsterResearch

<http://www.wmin.ac.uk/westminsterresearch>

Distortion correction of LDMOS power amplifiers using hybrid RF second harmonic injection/digital predistortion linearization.

Helias Koulouzis
Djuradj Budimir

School of Informatics

Copyright © [2006] IEEE. Reprinted from the proceedings of the IEEE Mediterranean Electrotechnical Conference, 2006. MELECON 2006, pp. 177-179.

This material is posted here with permission of the IEEE. Such permission of the IEEE does not in any way imply IEEE endorsement of any of the University of Westminster's products or services. Internal or personal use of this material is permitted. However, permission to reprint/republish this material for advertising or promotional purposes or for creating new collective works for resale or redistribution must be obtained from the IEEE by writing to pubs-permissions@ieee.org. By choosing to view this document, you agree to all provisions of the copyright laws protecting it.

The WestminsterResearch online digital archive at the University of Westminster aims to make the research output of the University available to a wider audience. Copyright and Moral Rights remain with the authors and/or copyright owners. Users are permitted to download and/or print one copy for non-commercial private study or research. Further distribution and any use of material from within this archive for profit-making enterprises or for commercial gain is strictly forbidden.

Whilst further distribution of specific materials from within this archive is forbidden, you may freely distribute the URL of the University of Westminster Eprints (<http://www.wmin.ac.uk/westminsterresearch>).

In case of abuse or copyright appearing without permission e-mail wattsn@wmin.ac.uk.

Distortion Correction of LDMOS Power Amplifiers using Hybrid RF Second Harmonic Injection/Digital Predistortion Linearization

H. Koulouzis, and D. Budimir

Wireless Communications Research Group, Department of Electronic Systems,
University of Westminster, London W1W 6UW, UK, Phone: +44(0)2079115139

Abstract - An LDMOS RF power amplifier for RF multichannel wireless systems with improved IMD performance characteristics is presented. The application of two combined linearization methods is being tested with the help of circuit simulation software ADS. The injection of the fundamental signal's second harmonic in the RF amplifier, as well as a digital predistortion technique, is combined in order to achieve IMD improvement. By proper selection of phase and amplitude of the injected second harmonic signal, it is possible to reduce IMD products that have already been reduced by the well established method of digital predistortion.

Index Terms—RF power amplifiers, Intermodulation distortion, LDMOS, digital predistortion

I. INTRODUCTION

The success of cellular wireless networks has resulted in the users of these networks requiring higher data rates for data intensive application such as accessing the internet, or applications on remote servers. However this requirement comes at a cost, both financially and in terms of technology development. In UMTS, the efficient utilisation of the communication channel has been achieved through the selection of QPSK as the modulation scheme. This modulation scheme is to be implemented as part of the Wideband Code Division Multiple Access technology.

Using a more complex digital modulation scheme such as QPSK where the information is contained both in the phase and envelope of the modulated signal, the requirements for amplifier linearity become more stringent. In this paper the implementation of the digital predistortion as well as the use of the Second Harmonic Injection Technique to reduce intermodulation distortion at the same time is tested. Additionally the paper shows the benefits of using a computer to design and simulate an amplifier and obtain its performances, instead of committing the design to hardware. The implementation of the Second Harmonic Injection Technique to improve linearity on a Si LDMOS based amplifier has been successful.

II. TECHNIQUE IMPLEMENTATION

In order to describe the principles of operation of this simple example of a digital pre-distortion linearizer a memoryless simplified model of the LDMOS amplifier is considered.

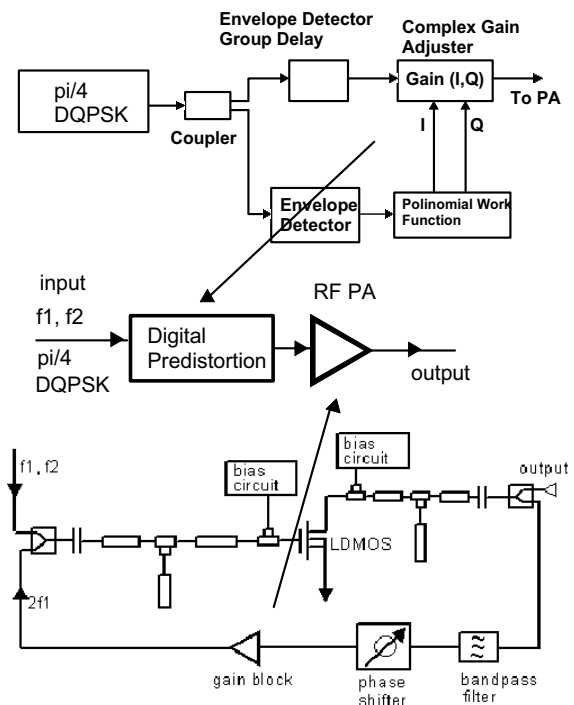

Fig. 1. A simplified block diagram of the hybrid RF SHI/DP linearizer

The ADS simulation, which was based on a simplified example, is using an iterative method in order to calculate the optimum values for the polynomial coefficients. An envelope detector is included in order to produce the Look Up Table indexing before the coefficients are used. The software is varying the coefficients from the initial value of 0 and monitoring the resultant Carrier to Intermodulation (C/I) in the output of the system. After several iterations the best possible combination is set for better C/I performance.

The technique of second harmonic injection to reduce third order intermodulation products is a well-established method originally reported in [1] and further researched in [2]. In the technique, second harmonics are fed from

the output to the input of the amplifier through a feedback loop and mixed with the fundamental input signals. The interaction of fundamental frequencies in the weakly non-linear amplifier results in the generation of third order IMD products which we will note as the primary. The further interaction of the fundamentals signals with that of the injected second harmonics result in additional third order IMD products (the secondary) being generated but with an amplitude and phase variation which is different from that of the primary. By careful selection of the amplitude and phase of the second harmonics, we can affect the amplitude and phase of the secondary third order IMD products such that this secondary is able to cancel the primary third order IMD products [2]. The block diagram for this system is shown in Figure 1. From the block diagram, it can be seen that the feedback system to be implemented consists of a bandpass filter, to filter the second harmonic frequencies at $2f_1$ and $2f_2$, a phase shifter which is allowed to vary between 0° and 360° , and a gain stage or small signal amplifier. In some cases, depending on the performance of the semiconductor transistor technology and the spectral re-growth of the second order IMD products an attenuator is used in place of the gain stage.

In order to implement and test the theory [2], the feedback loop components contained a filter to filter out the wanted bandwidths in the frequency range of 2.11 to 2.17 GHz and second harmonics in the frequency range of 4.22 GHz to 4.34 GHz. This is then followed by an analogue phase shifter and gain section. Another filter is placed on the input of the amplifier to allow for injection of the fed back second harmonics products into the input of the amplifier.

III. SIMULATION RESULTS

The initial stage of the test was to analyse the performance of the amplifier using the two tone approach [1]. The initial settings for this test were 5 dBm input power, 1 KHz frequency separation with the two frequencies located at 2.14 GHz and 2.1401 GHz respectively. The phase shifter and gain block were then adjusted by a tedious trail and error approach till an improved third order intermodulation distortion response was obtained.

The unlinearised response together with the linearised responses are plotted in Figures 2a, 2b and 2c. Comparing graph 2a with 2b we see an immediate improvement of 45 dB in third order intermodulation products. With this positive result the second harmonic injection method was also implemented with a further improvement of 51 dB, as sown in 2c. This adds up to a total of 96 dB of improvement.

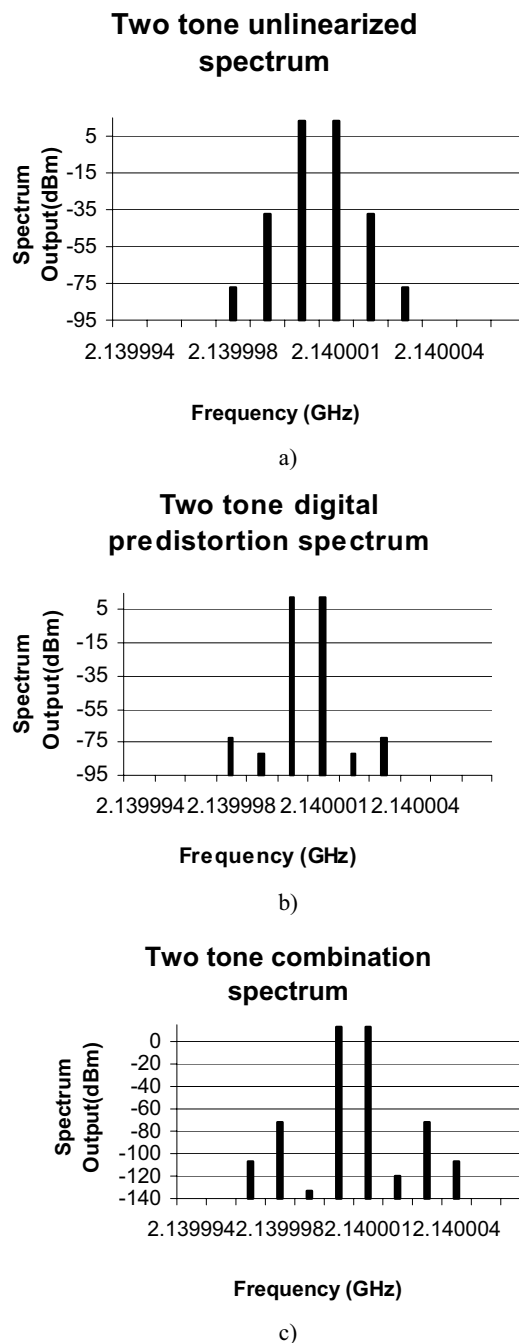

Fig. 2. a) unlinearised output, b) digital predistortion output c) the output of the combination of both methods for 5 dBm input power.

The following simulation test was performed to investigate the performance of the 2 linearization methods under a WCDMA signal.

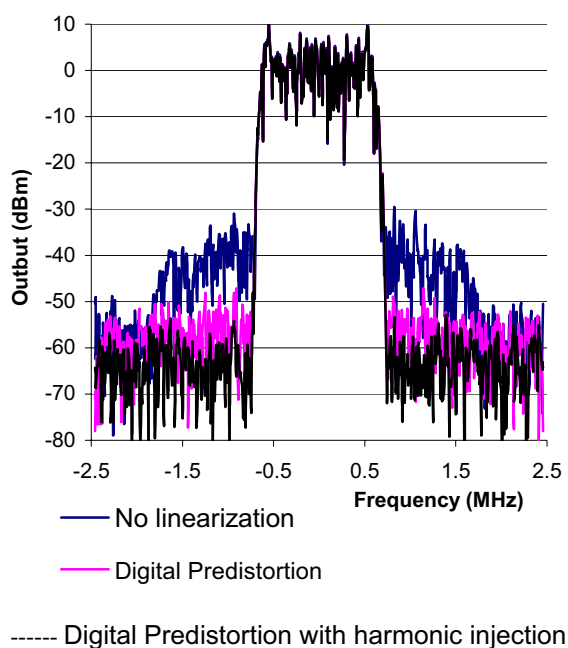

Fig. 3. Simulated Spectrum Outputs

The resultant output for the WCDMA signal tests is shown in Figure 3. As with the two tone result it can be seen that improvement in intermodulation performance is achieved over the standard unlinearised design. Digital predistortion gives an improvement of ACPR of around 15 and with the use of 2nd harmonic feedback a further improvement of around 10 was observed.

IV. CONCLUSION

The above results have demonstrated that the objective of third order intermodulation distortion reduction has been achieved. The only drawback to the feedback system is that for a varying input, the gain and particularly the phase need to be adjusted to compensate for AM-AM and AM-PM conversion. What has also been confirmed in this paper is the impact with which

AM-AM and AM-PM conversion impacts and distorts a signal. This is particularly evident when comparing the simulated results for an amplifier with and without linearisation. The characterization of an LDMOS FET has been confirmed and the mathematical model of weakly nonlinear model has been verified. This has resulted in the successful application of the second harmonic injection technique to reduce intermodulation distortion in LDMOS FET.

REFERENCES

- [1] Yongcai Hu, Jean Claude Mollier and Juan Obregon, "A New Method of Third-Order Intermodulation Reduction in Nonlinear Microwave Systems". *IEEE Transactions on Microwave Theory and Techniques*, Vol. MTT-34, No 2, February 1986, pp 245 – 250.
- [2] C. S. Aitchison, M. Mbabele, M. R. Moazzam, D. Budimir, and F. Ali, 'Improvement of third order intermodulation products of RF and microwave amplifiers by injection', *IEEE MTT Transactions on Microwave Theory and Techniques*, pp. 1148-1154, Vol. MTT-49, No 6, June 2001.
- [3] D. Budimir, H. Koulouzis and K. Williams, "LDMOS RF Power Amplifiers with Improved IMD Performance", *34th European Microwave Conference Proc.*, Amsterdam, The Netherlands, 11-15 October 2004.
- [4] H. Koulouzis and D. Budimir, "Design of High Efficiency LDMOS Power Amplifiers", *Postgraduate Research Conference in Electronics, Photonics, Communications & Networks, and Computing Science (PREP'04)*, 5-7, April, 2004, University of Hertfordshire, UK.
- [5] C. Fager, N.B. de Carvalho, J.C. Pedro and H. Zirath, "Intermodulation Distortion Behaviour in LDMOS Transistor Amplifiers", *IEEE MTT-S Digest*, pp.131-134, 2002.
- [6] J. K. Cavers, "Amplifier Linearization Using a Digital Predistortion with Fast Adaptation and Low Memory Requirements", *IEEE Transactions on Vehicular Technology*, Vol. 39, No. 4, pp. 374-382, November 1990.
- [7] A. S. Wright and W. G. Durtler, "Experimental Performance of an Adaptive Digital Linearized Power Amplifier", *IEEE Transactions on Vehicular Technology*, Vol. 41, No. 4, pp. 395-400, November 1992.