

PDF hosted at the Radboud Repository of the Radboud University Nijmegen

The following full text is a publisher's version.

For additional information about this publication click this link.

<http://hdl.handle.net/2066/22098>

Please be advised that this information was generated on 2018-07-07 and may be subject to change.

ORIGINAL INVESTIGATION

Tuija Sulisalo · Ineke van der Burgt · David L. Rimo
 Jaques Bonaventure · David Silience · John B. Campbell
 David Chitayat · Charles I. Scott · Albert de la Chapelle
 Pertti Sistonen · Ilkka Kaitila

Genetic homogeneity of cartilage-hair hypoplasia

Received: 8 July 1994

Abstract Cartilage-hair hypoplasia (CHH) is an autosomal recessive metaphyseal chondrodysplasia characterized by short stature and hypoplasia of the hair. Associated pleiotropic features include deficient erythropoiesis, impaired T-cell mediated immunity, Hirschsprung's disease, and an increased risk of malignancies. CHH is most prevalent among the Old Order Amish in the United States and among the Finns, but sporadic families have been described among many other populations. We have previously mapped the gene for CHH to the short arm of chromosome 9 in Finnish and Amish families. The CHH locus resides close to D9S163 within an interval of 1.5 cM flanked by D9S165 and D9S50. In order to investigate the genetic homogeneity of CHH in various populations, we studied nine families with no genealogical connections to

either Amish or Finns. No recombinants were detected between the CHH gene and any of the three closest marker loci studied, suggesting that CHH in these families results from mutation(s) at the same locus as in the Amish and Finnish families.

Introduction

Cartilage-hair hypoplasia or McKusick type metaphyseal chondrodysplasia (MIM No. 250250) is an autosomal recessive disorder resulting in short-limbed short stature and poor hair growth (McKusick et al. 1965; Mäkitie and Kaitila 1993). Associated pleiotropic features include deficient erythropoiesis, impaired T-cell mediated immunity, intestinal problems such as Hirschsprung's disease, and an increased risk of malignancies. Although the pathogenesis of CHH is unknown, defective proliferation of T- and B-lymphocytes and fibroblasts, and defective erythropoiesis suggest a more generalized defect in cellular proliferation.

CHH was first described among the Old Order Amish in the United States (McKusick et al. 1965) and was later also shown to be a relatively common cause of short stature among the Finns (Perheentupa 1972). Gene frequencies of 0.05 and 0.0066 have been estimated in these populations, respectively (McKusick et al. 1965; Mäkitie 1992). Data on gene frequencies among other populations are not available, but sporadic families have been described among many populations, including the Dutch, Polish, French, Germans, Danes, Algerians, Italians, Spanish, non-Amish Americans, and the Mexicans (reviewed in Mäkitie 1992).

We have previously assigned the gene for CHH to chromosome 9 by linkage in Finnish and Amish families (Sulisalo et al. 1993, 1994a). The CHH gene has been mapped to an area of approximately 1.5 cM flanked by D9S165 and D9S50, and is close to D9S163 (Sulisalo et al. 1994b). No recombinations have been detected between the CHH gene and D9S163, and a statistically significant linkage disequilibrium was observed between these loci in both Amish and Finnish families (Sulisalo et al. 1994a, b). Luria-Delbrück method-based calculations (Hästbacka et

T. Sulisalo (✉) · A. de la Chapelle · I. Kaitila
 Department of Medical Genetics,
 P.O. Box 21, FIN-00014 University of Helsinki, Helsinki, Finland

I. van der Burgt
 Department of Human Genetics, University Hospital Nijmegen,
 Nijmegen, The Netherlands

D. L. Rimo
 Cedars-Sinai Medical Center, Los Angeles, USA

J. Bonaventure
 CNRS, Hospital Necker, Paris, France

D. Silience
 The Children's Hospital, Sidney, Australia

J. B. Campbell
 Arnold Palmer Hospital for Children & Women, Orlando, USA

D. Chitayat
 The Hospital for Sick Children, Toronto, Canada

C. I. Scott
 Alfred I. duPont Institute, Delaware, USA

P. Sistonen
 Finnish Red Cross Blood Transfusion Service, Helsinki, Finland

I. Kaitila
 Department of Medical Genetics,
 Helsinki University Central Hospital, Helsinki, Finland

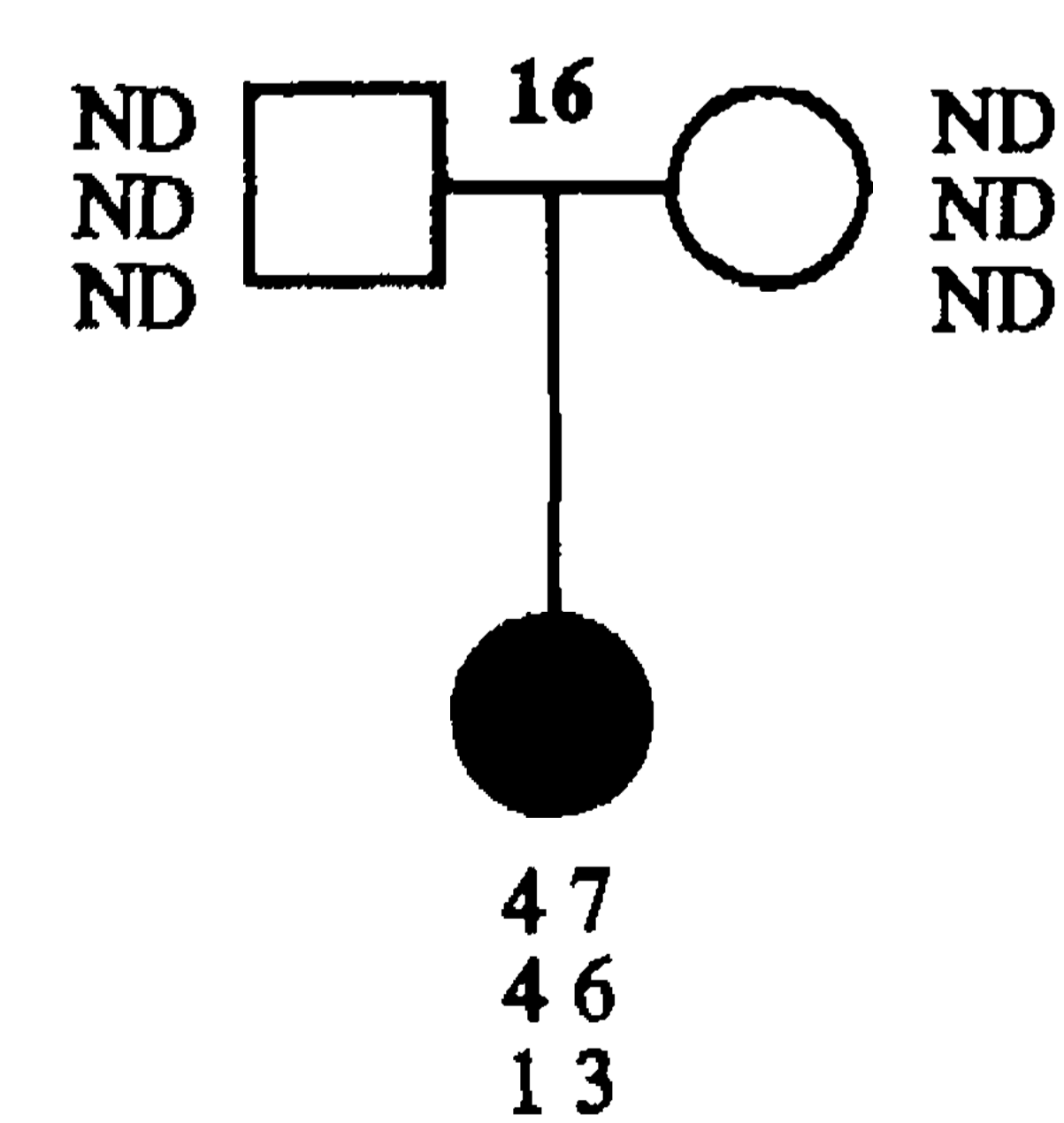
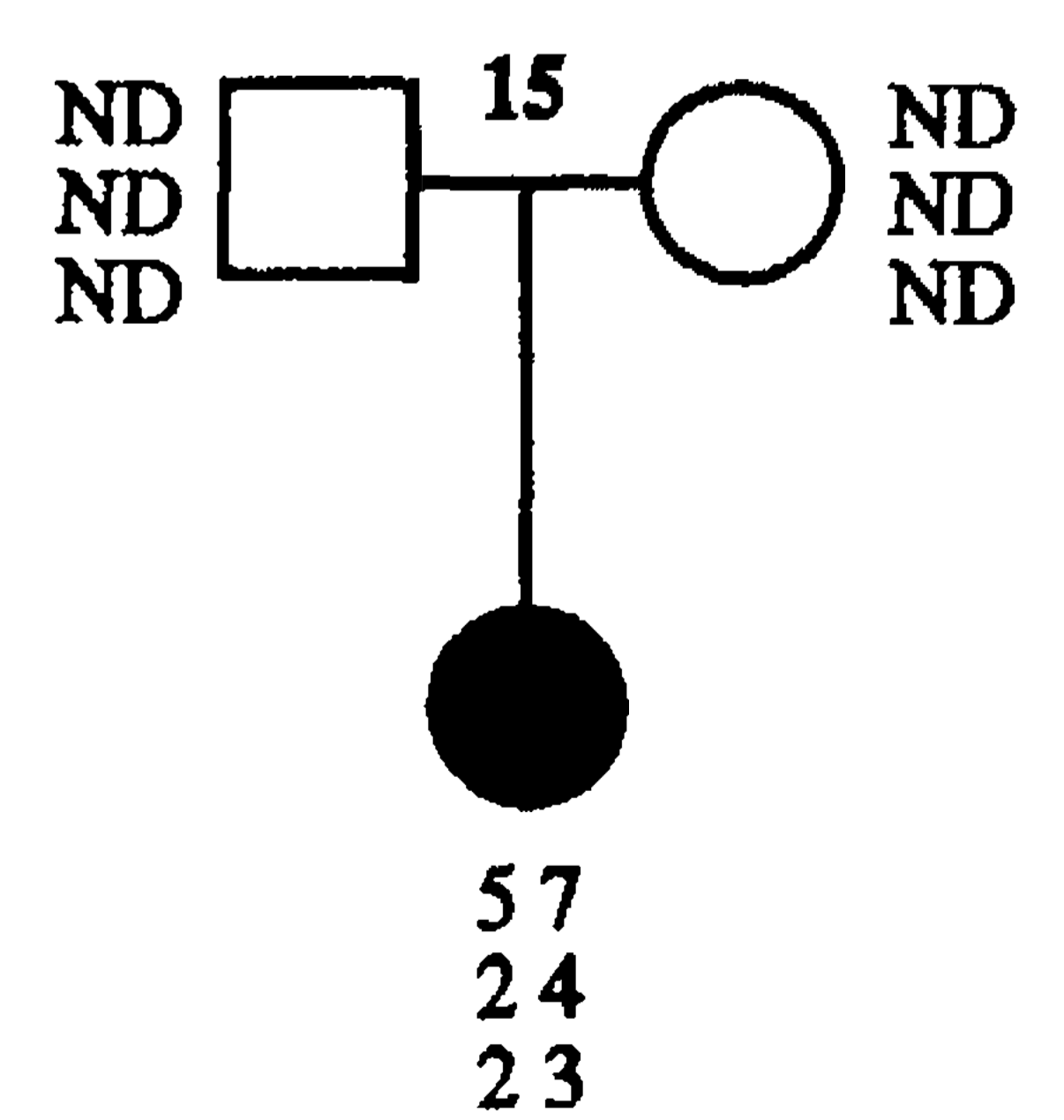
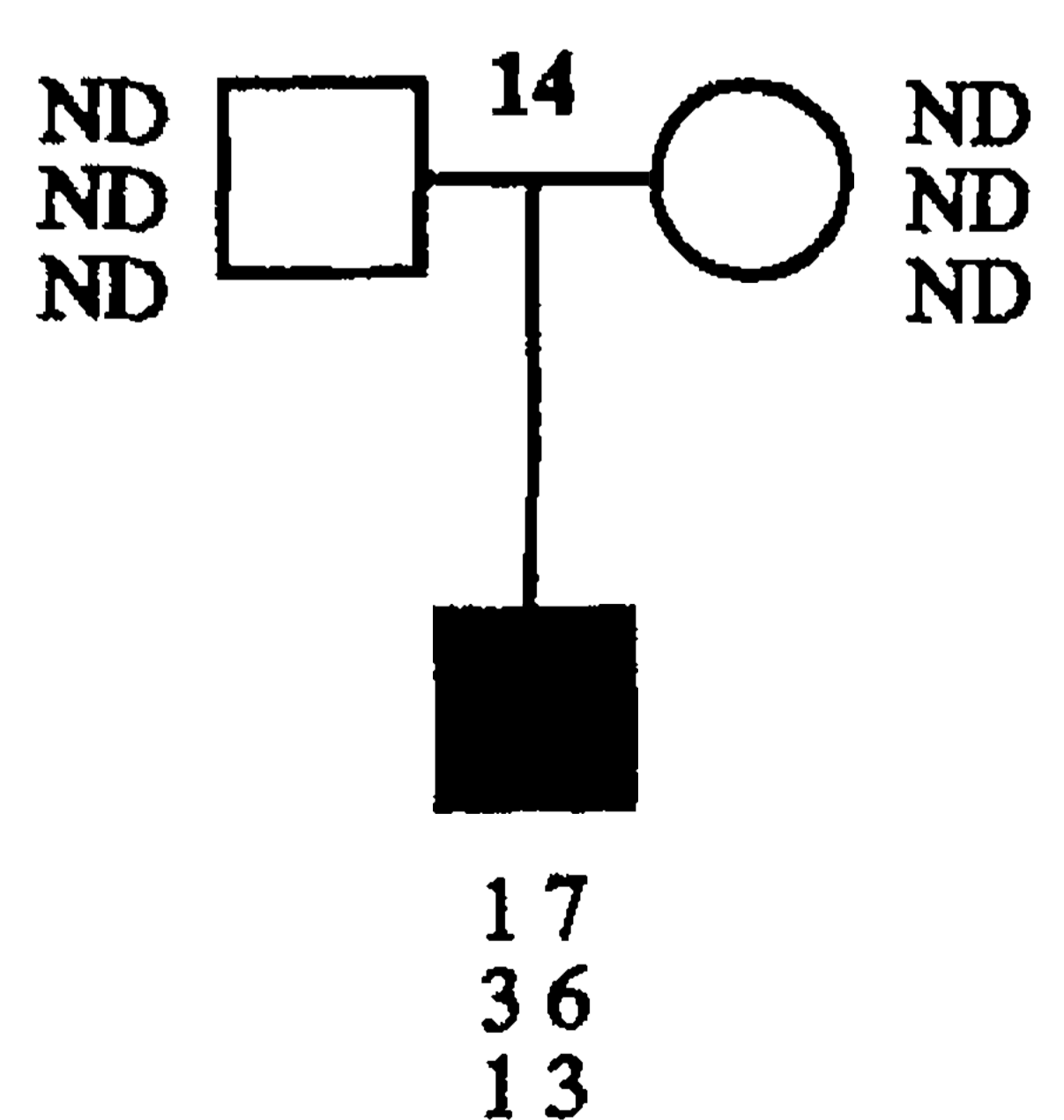
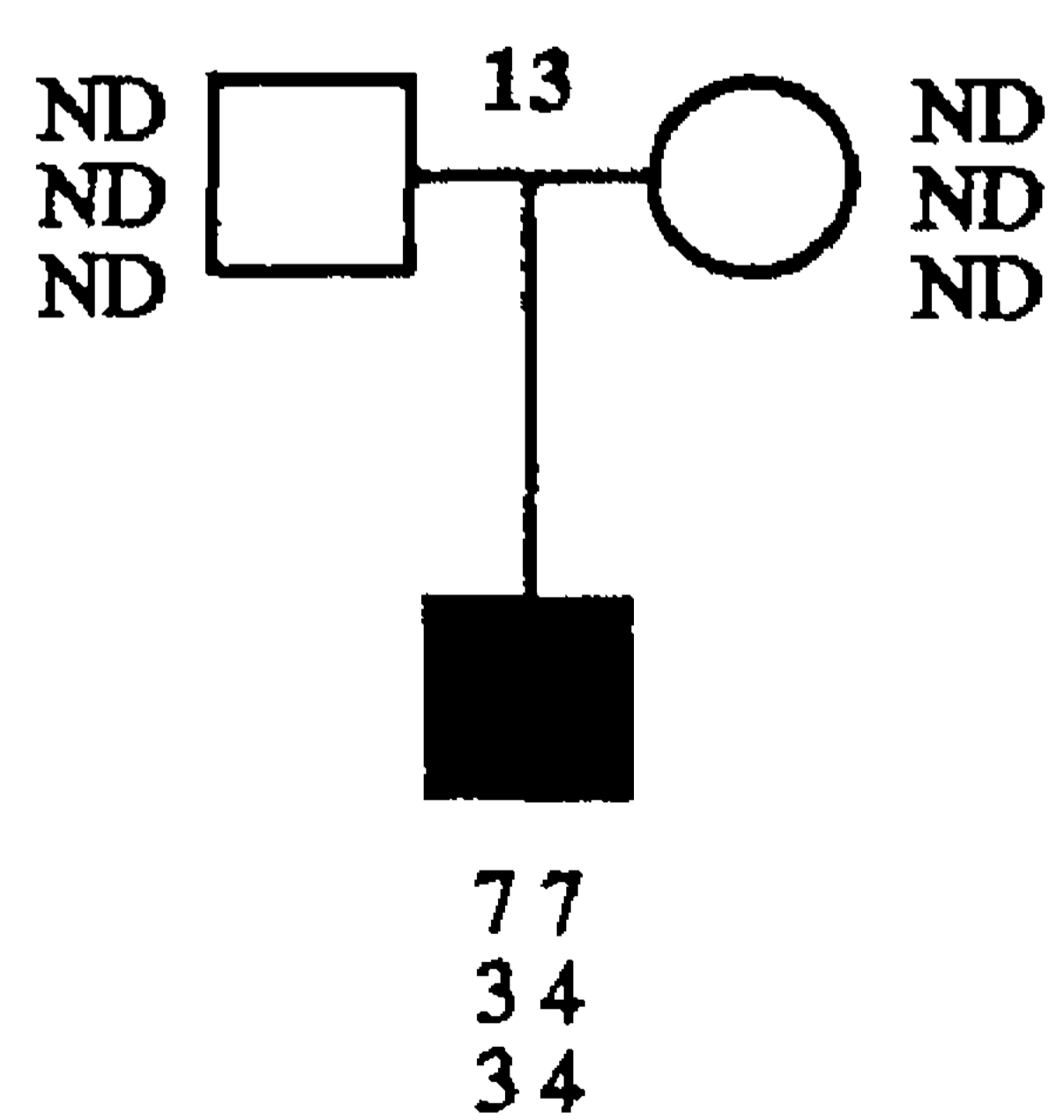
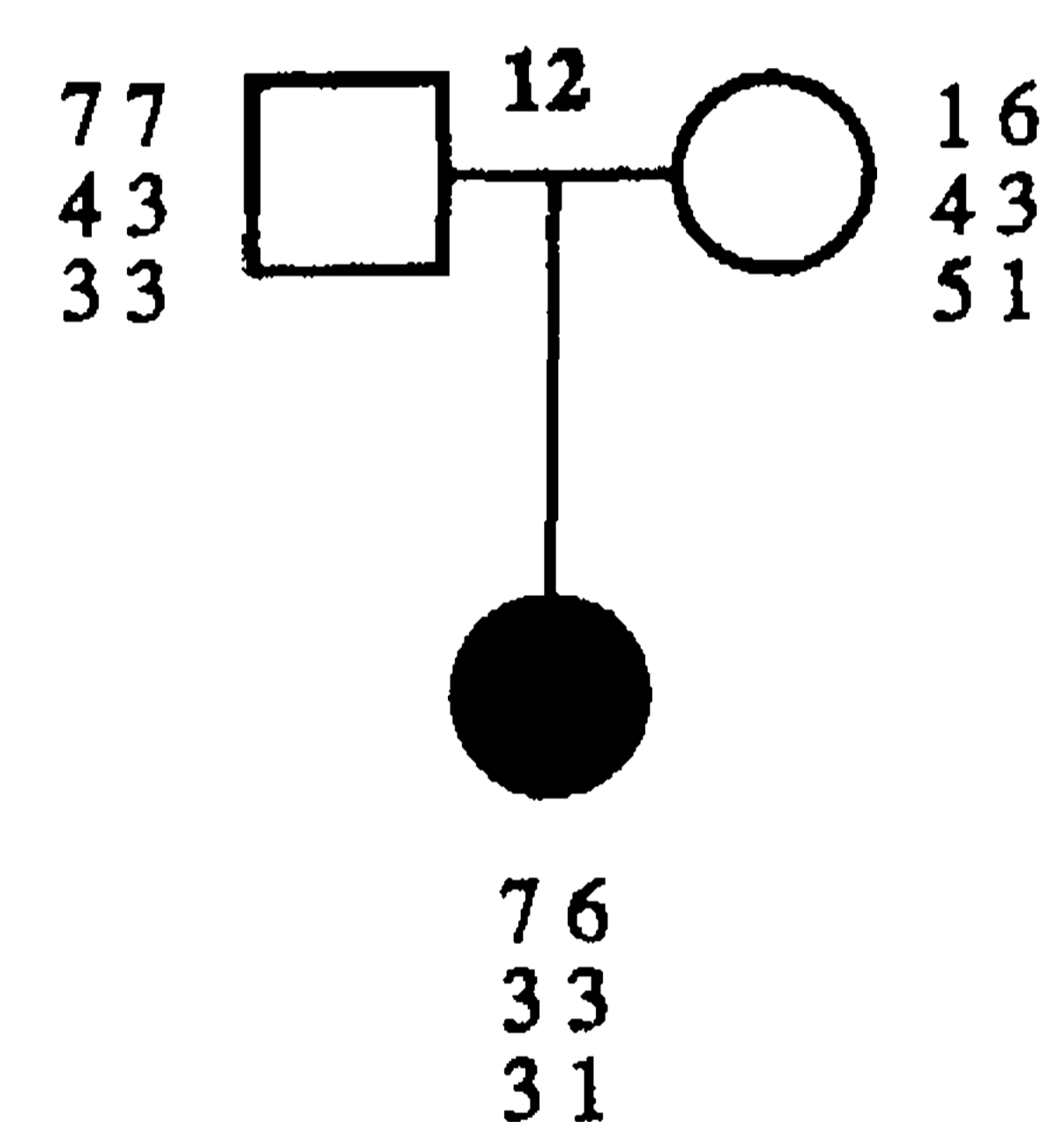
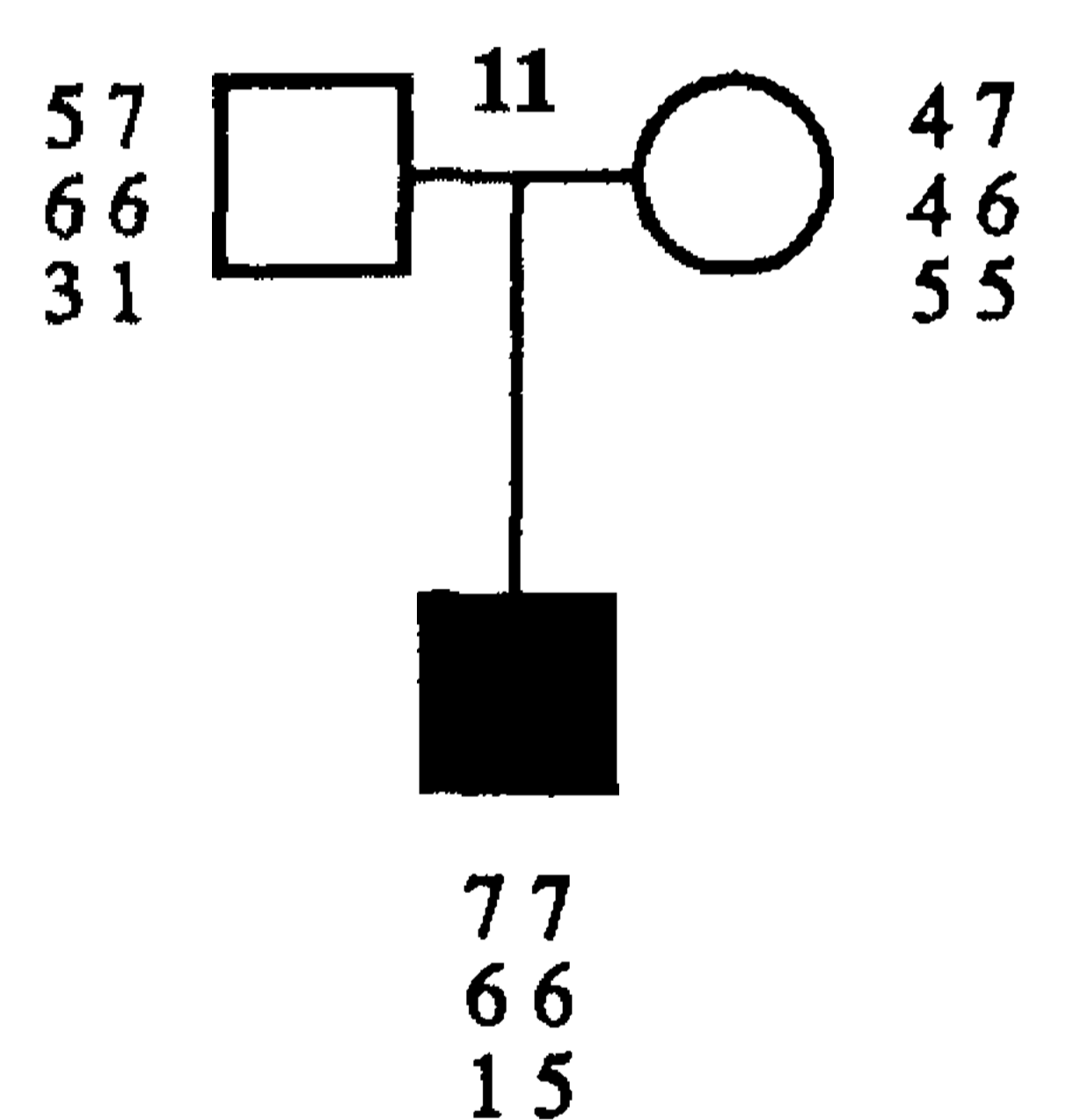
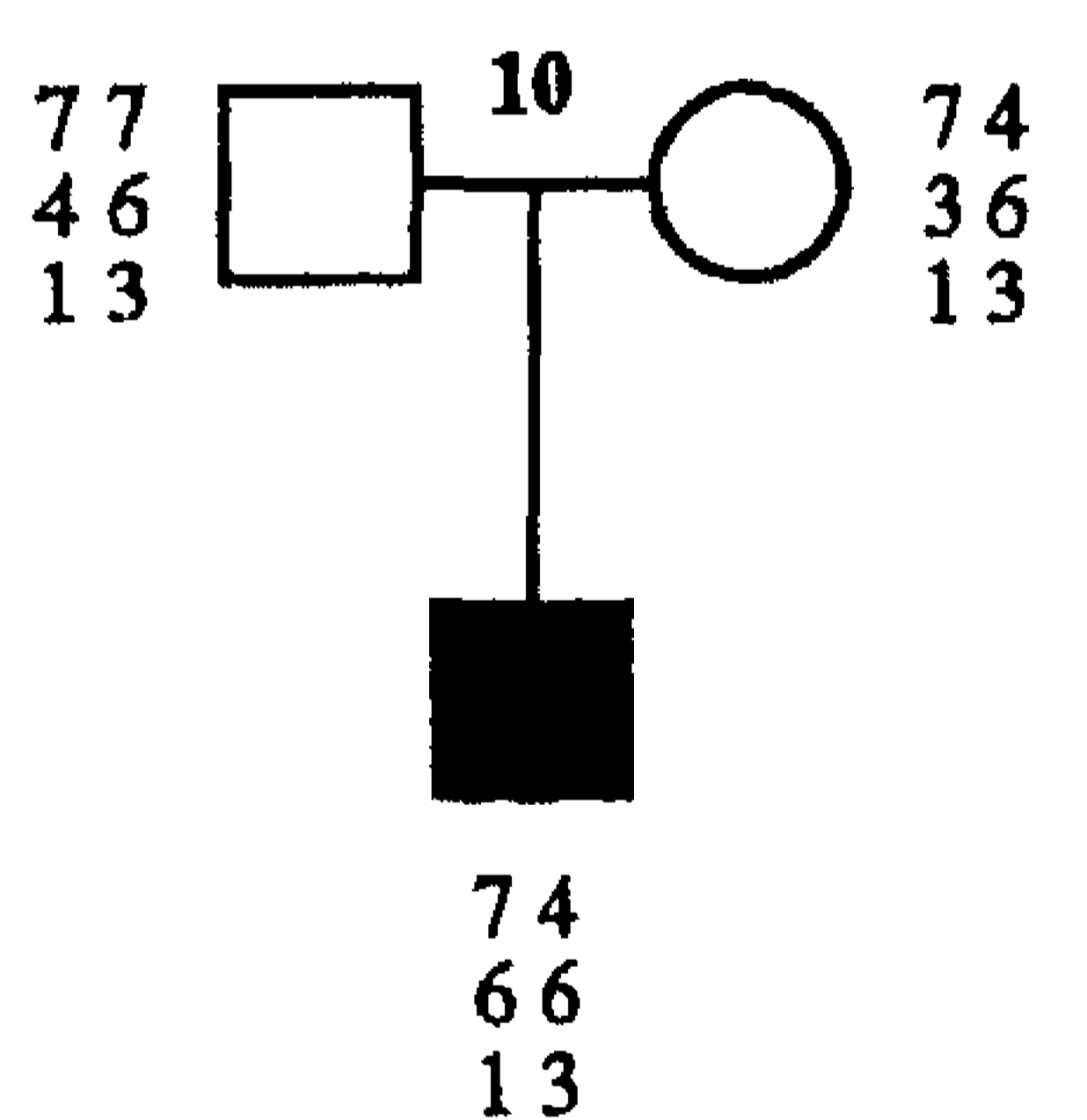
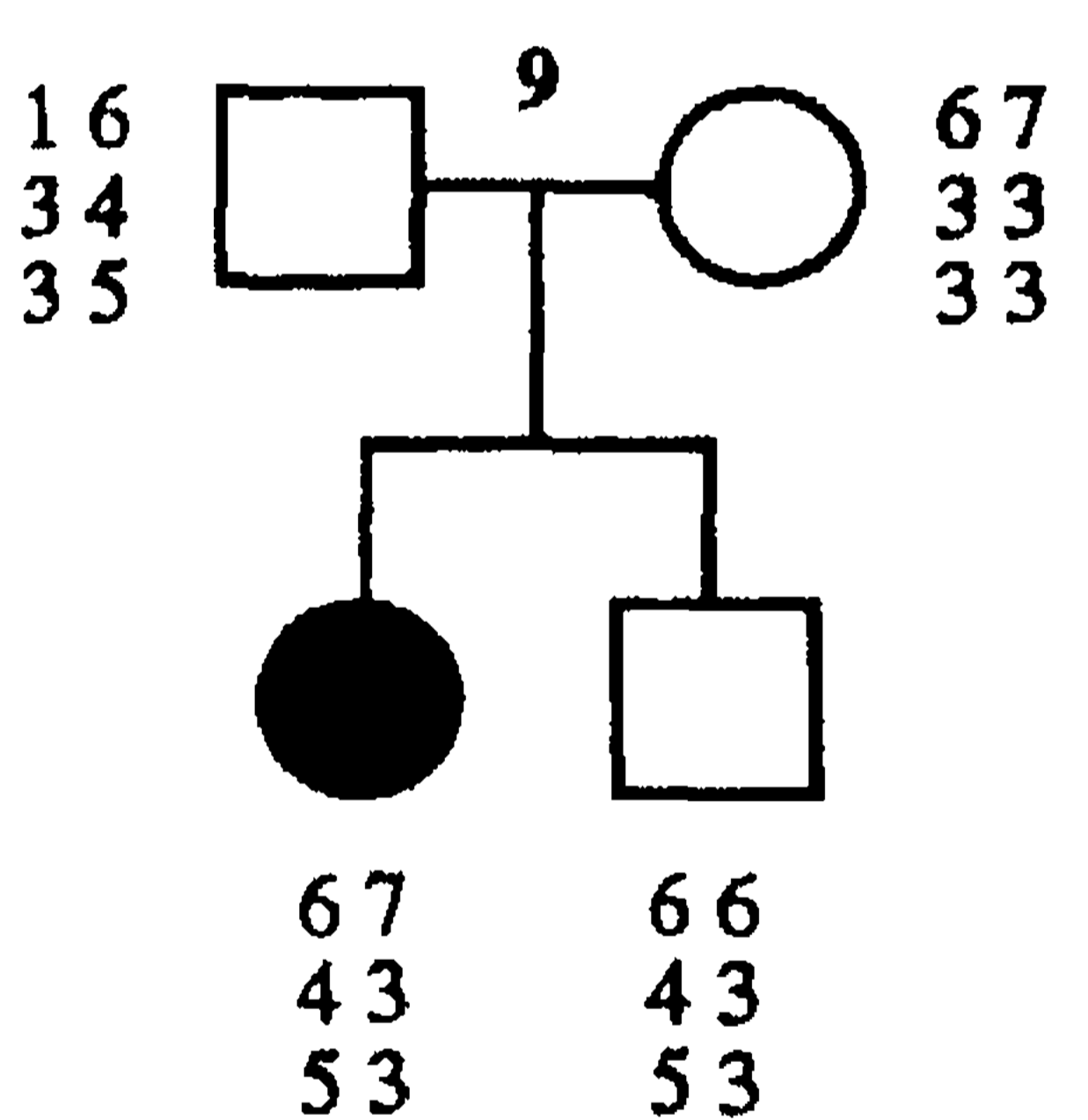
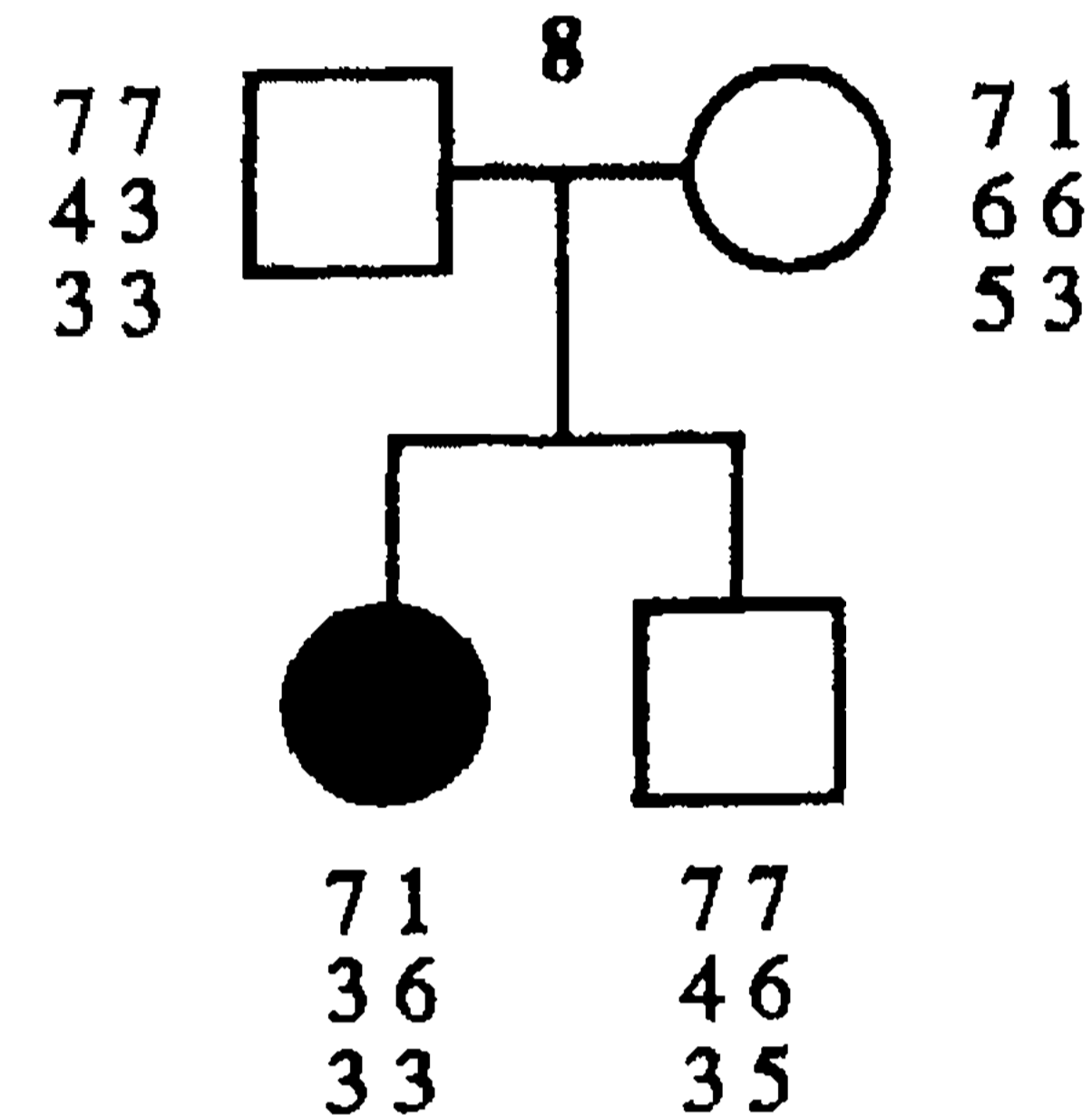
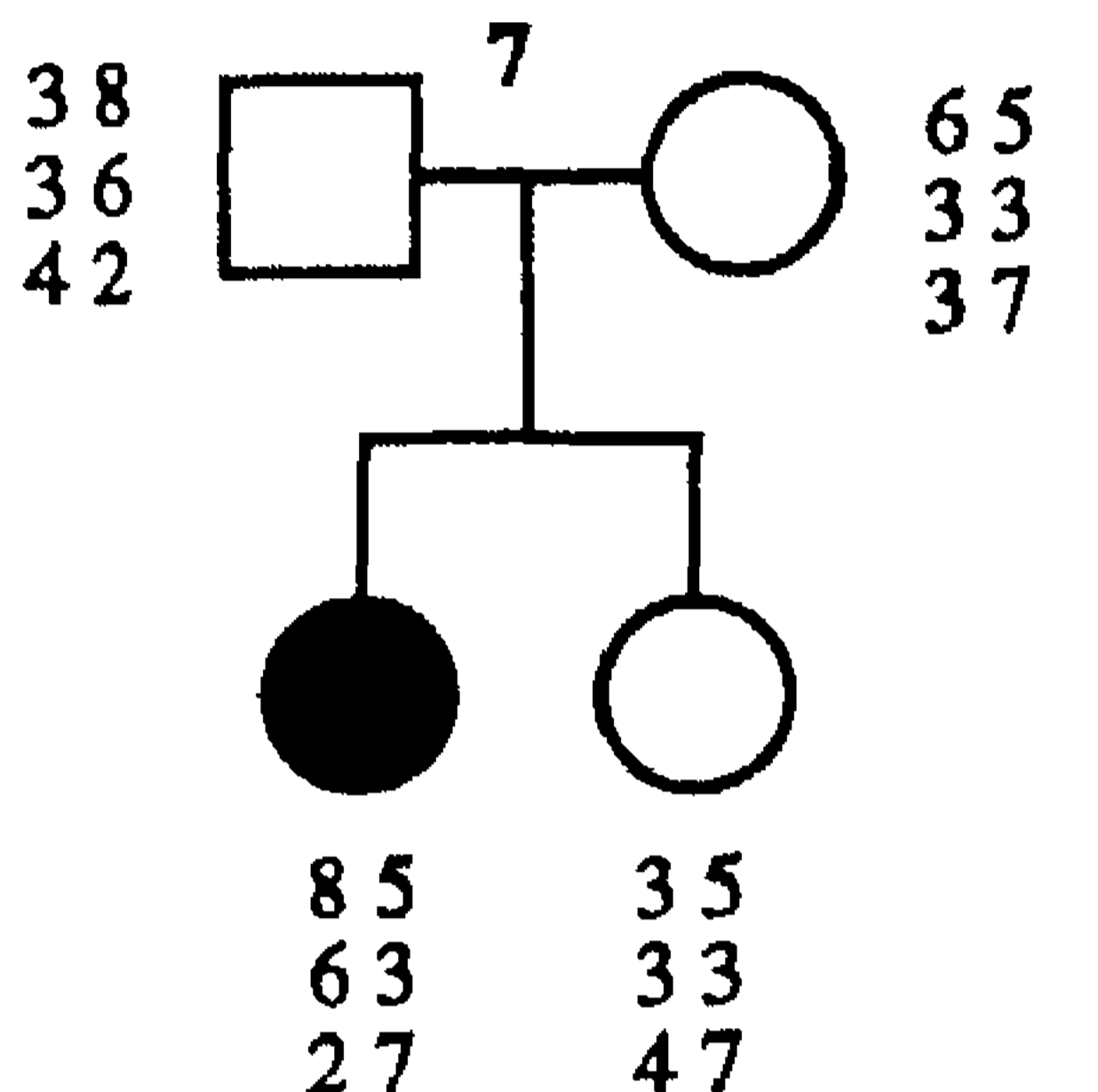
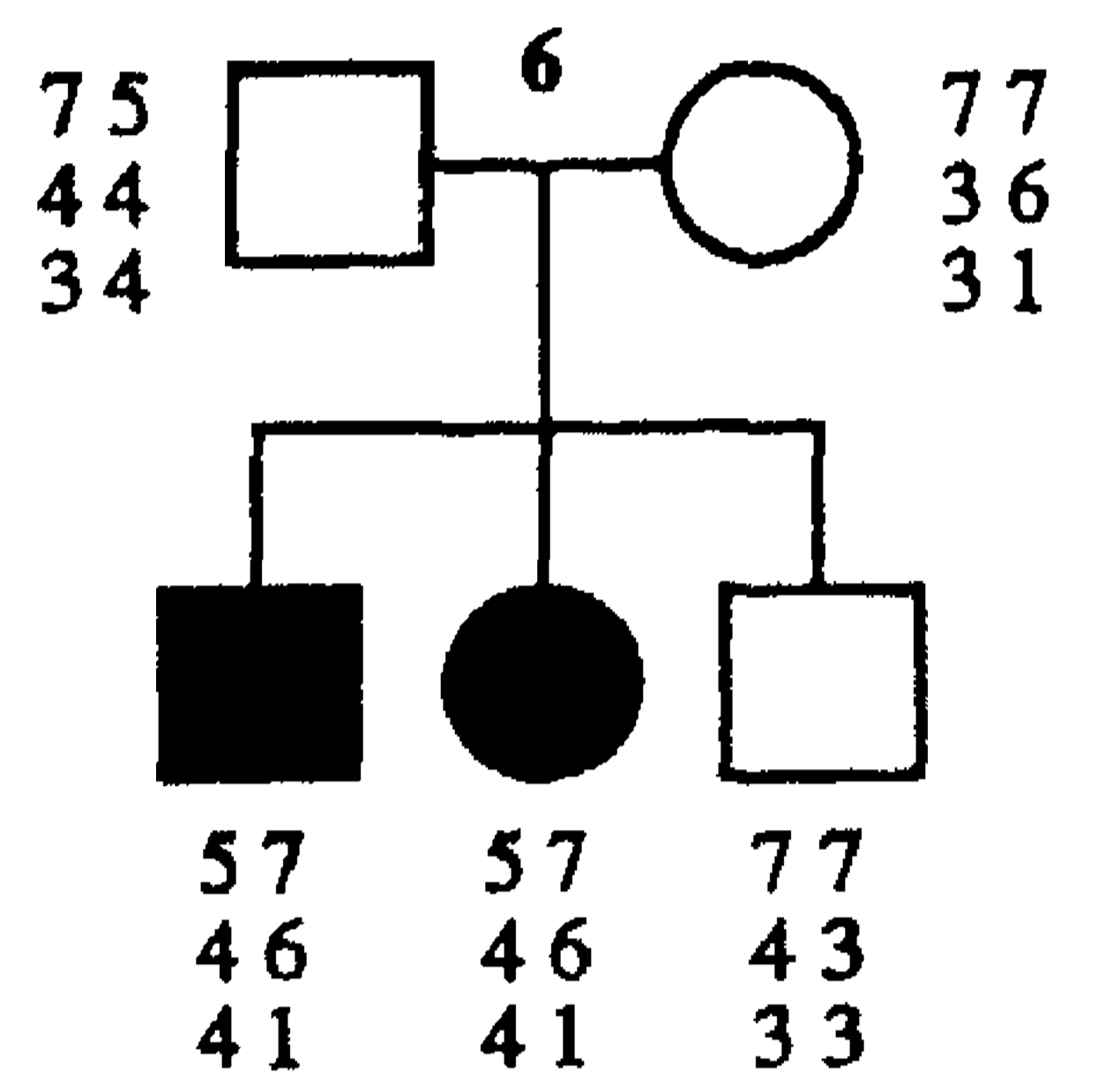
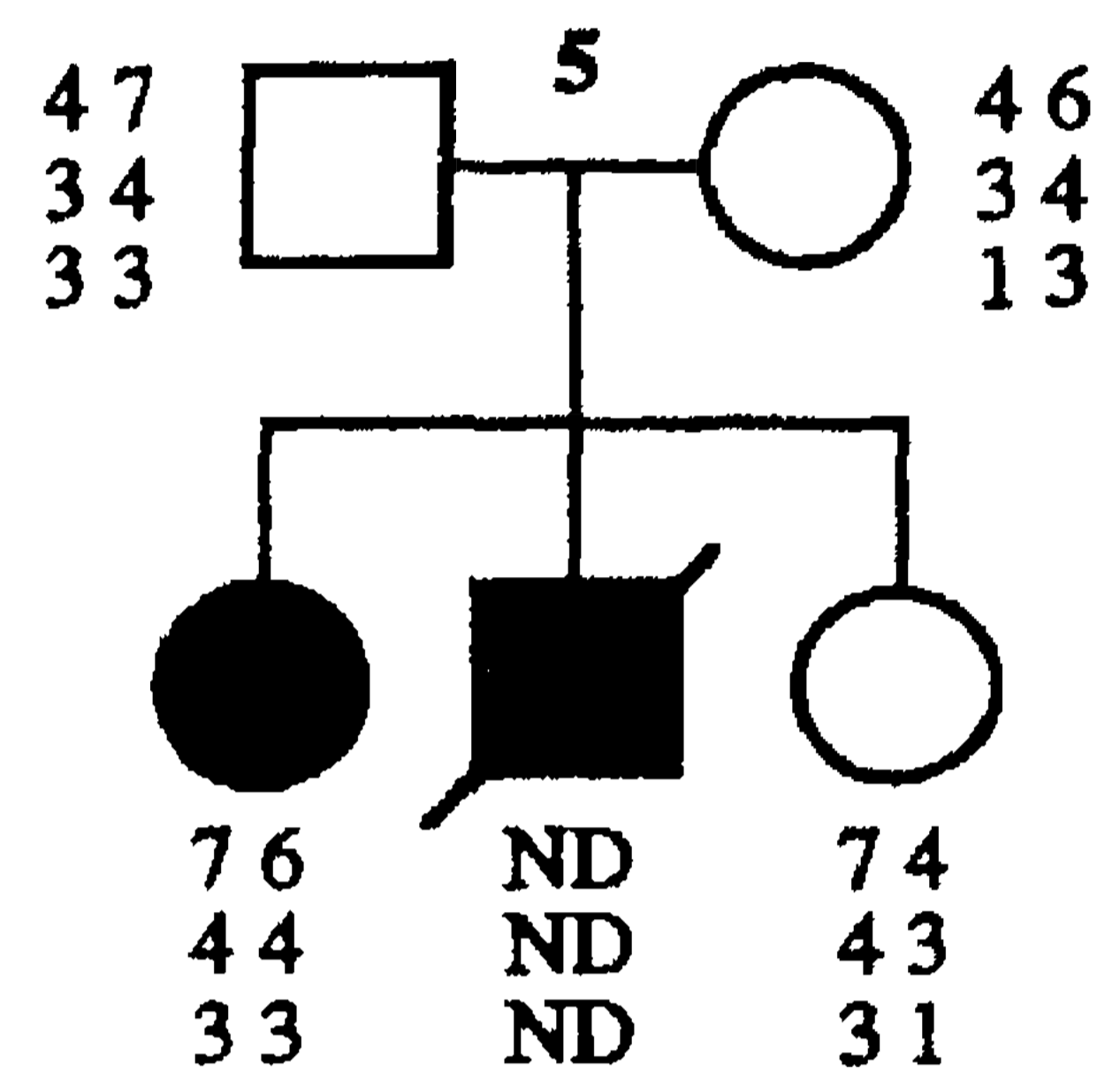
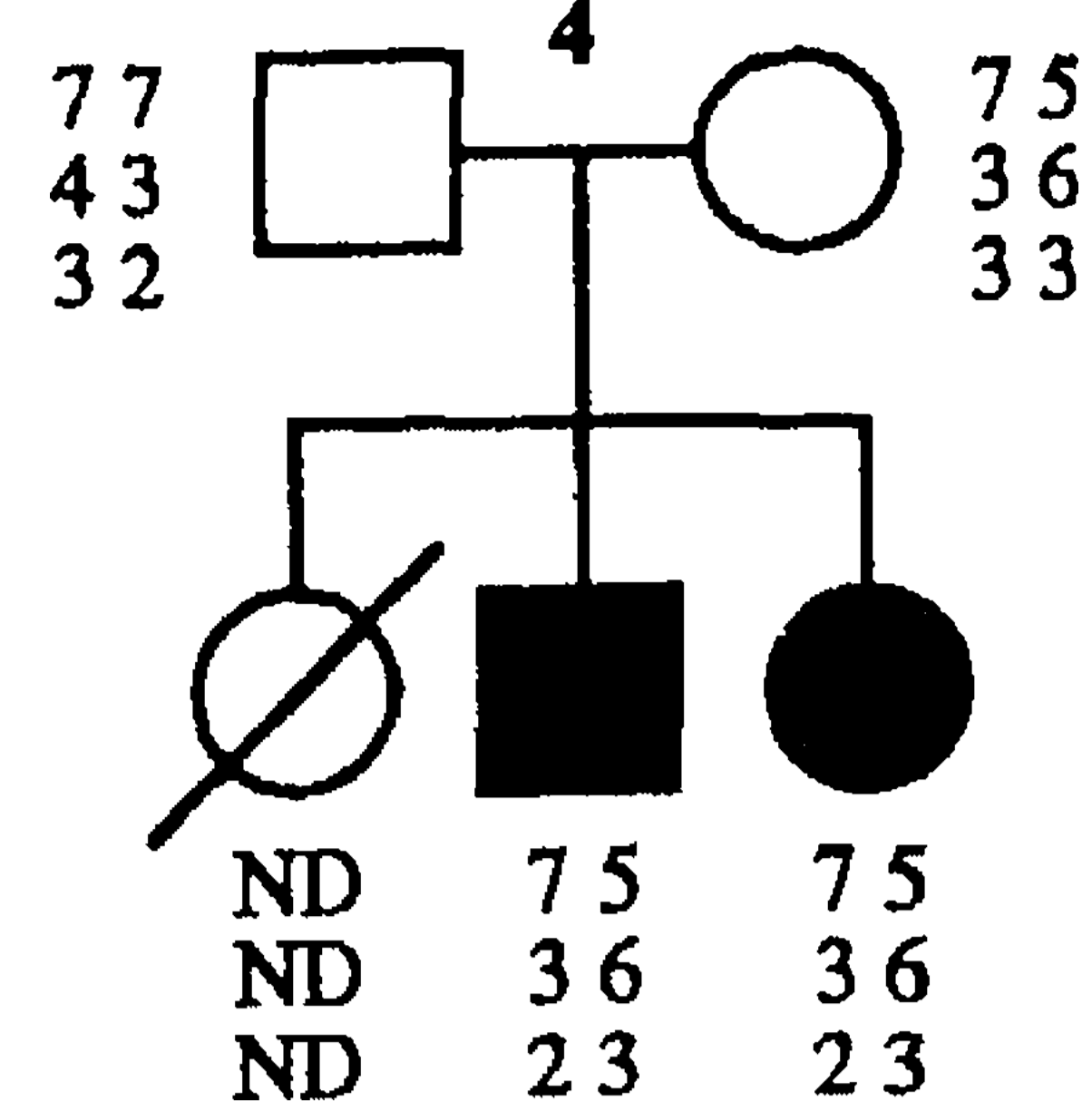
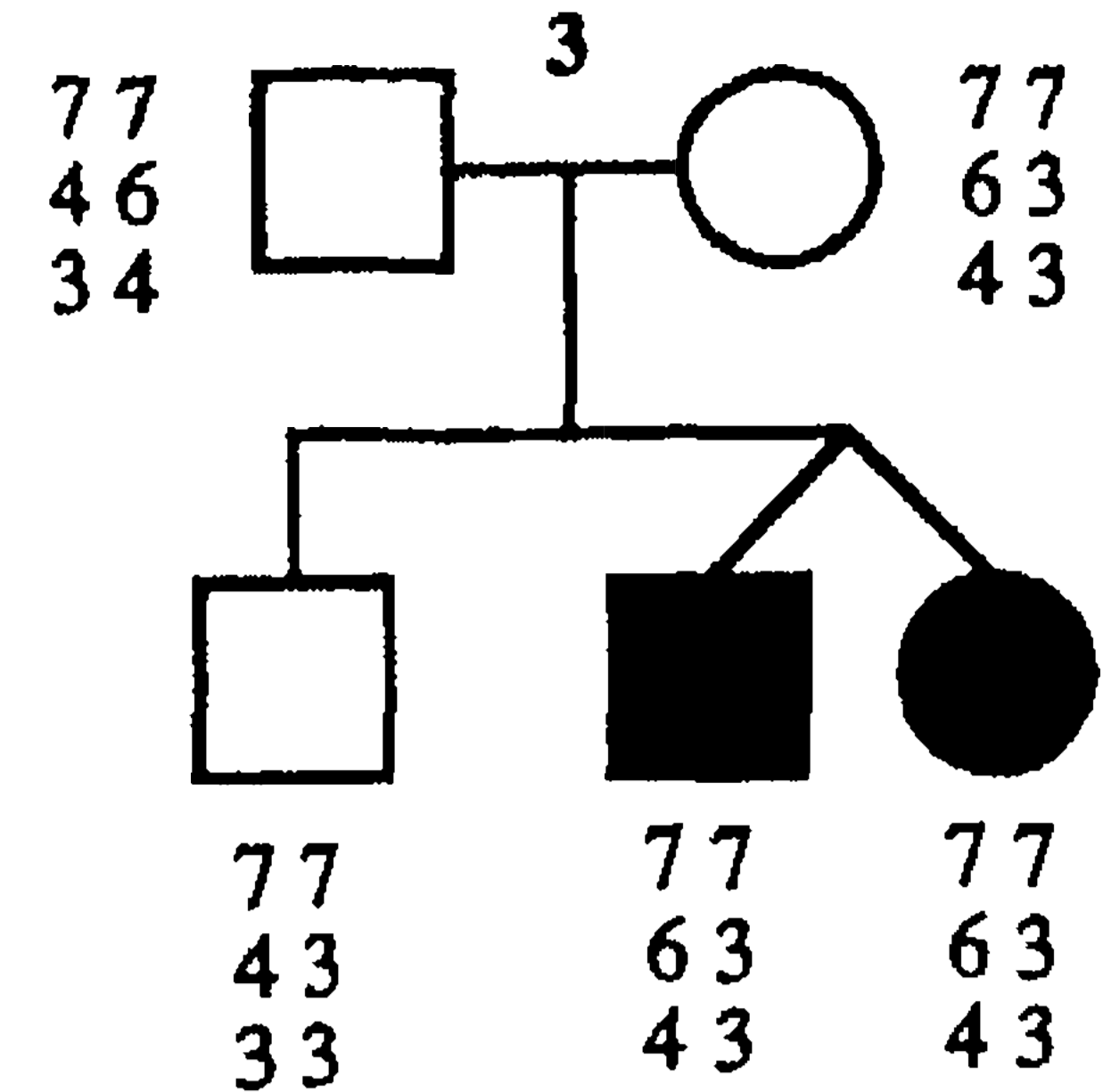
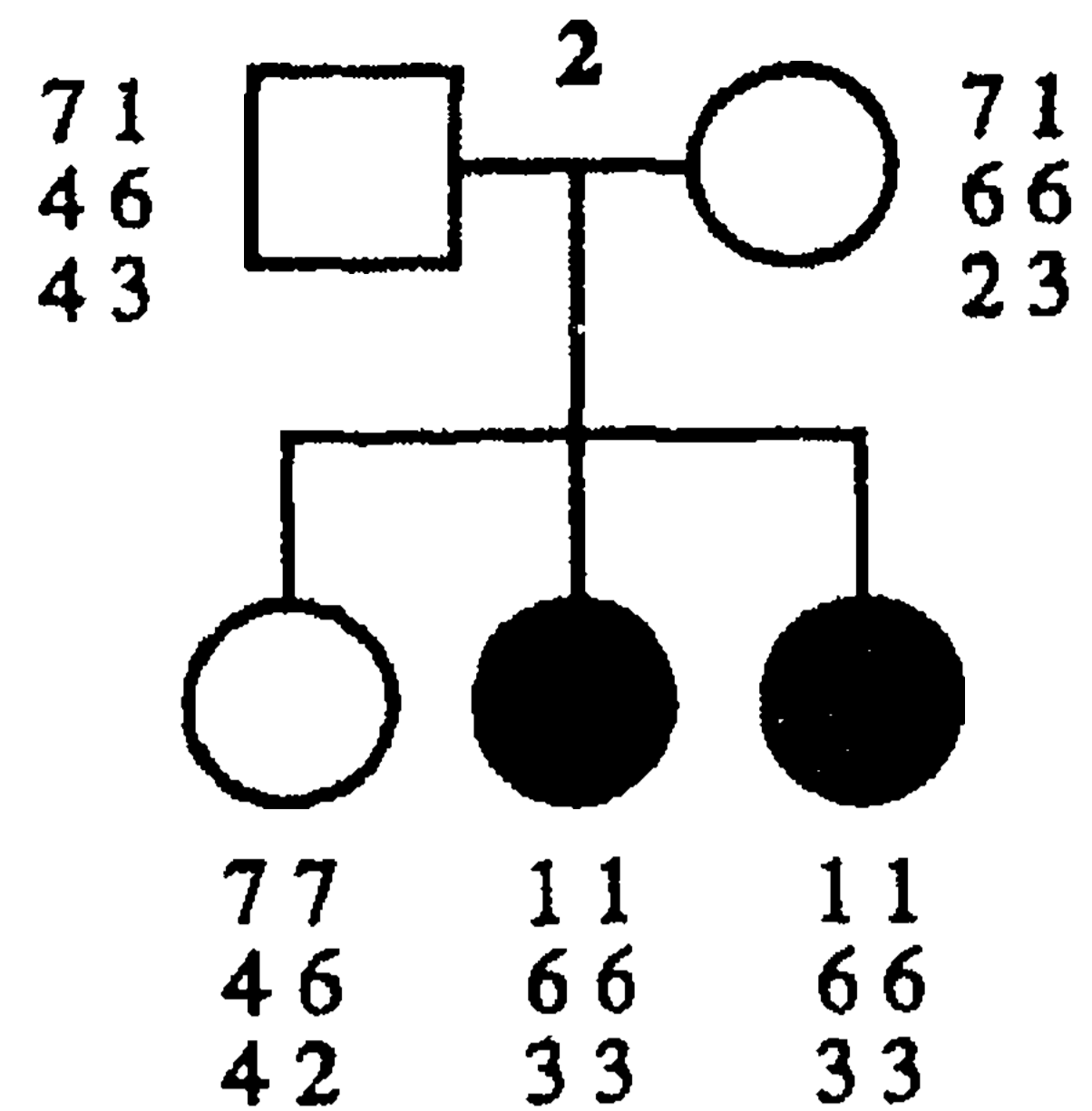
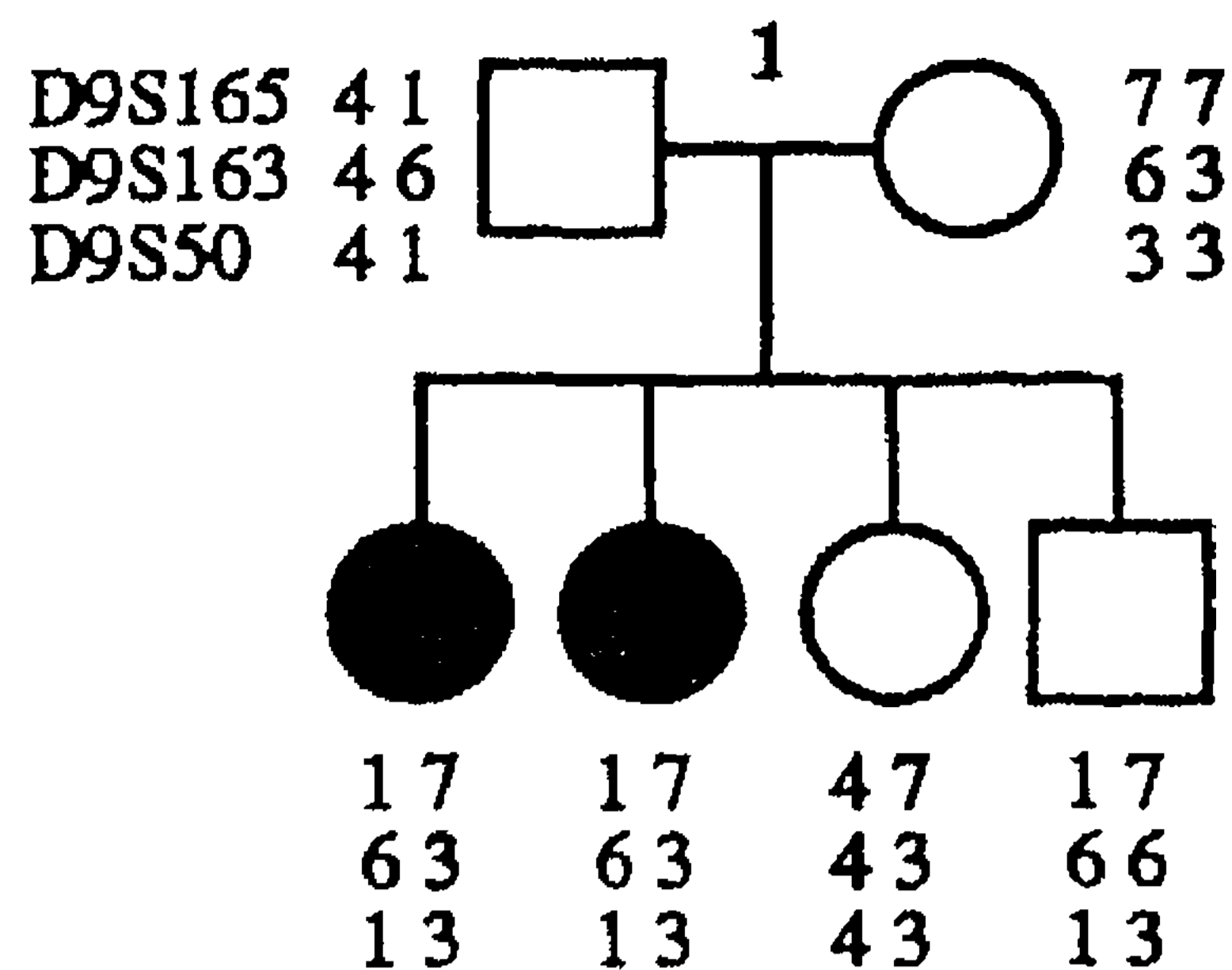

◀ **Fig. 1** Pedigrees of the families studied. The haplotypes for D9S165, D9S163, and D9S50 are shown for all individuals studied. The phase could not be determined for the marker alleles in all cases. *Square* Male, *circle* female, *open symbol* unaffected, *filled symbol* affected, *all symbols with diagonal* deceased, *ND* not determined

al. 1992; Lehesjoki et al. 1993) suggest an approximate distance of 0.3 cM between CHH and D9S163 (Sulisalo et al. 1994b).

Here, we have studied nine CHH families for which neither Amish nor Finnish ancestors are known. In addition, seven sporadic cases were studied. These families originate from the Netherlands, Poland, France, Croatia, the United States, and Canada.

Materials and methods

Patients

The pedigrees of the families are shown in Fig. 1. Families 1 and 2 come from the Netherlands, family 3 from Poland, family 4 from France, family 5 from Australia (originally from Croatia), families 6–8 and 10–16 from the United States, and family 9 from Canada. Diagnosis was performed by I.v.d.B. in families 1–3 (van der Burgt et al. 1991), by J.B. in family 4, by D.S. in family 5, by D.L.R. in families 6–7 and 10–15, by C.I.S. in family 8, by D.C. in family 9, and by J.B.C. in family 16. The diagnostic criteria are short-limbed short stature, generalized laxity of joint ligaments, and metaphyseal flaring and irregularities of the growth plates in childhood radiographs. Poor hair growth is used only as a positive criterion (McKusick et al. 1965; Mäkitie and Kaitila 1993).

DNA samples

DNA was extracted from blood or lymphoblastoid cell lines according to standard methods.

Polymerase chain reaction and detection of microsatellite markers

The polymerase chain reaction protocols for the detection of microsatellite markers have been described previously (Sulisalo et al. 1993). Microsatellite markers detecting D9S165, D9S163, and D9S50 were studied (Weissenbach et al. 1992; Wilkie et al. 1992).

Linkage analysis

Pairwise linkage analysis was performed using the MLINK program of the LINKAGE package (Lathrop et al. 1984). Multipoint analysis against a fixed marker map of three loci, D9S165, D9S163, and D9S50, was carried out using the LINKMAP program and assuming a constant female/male sex difference ratio of 2.75 and distances as previously reported (Sulisalo et al. 1994b). The CHH gene was considered fully penetrant and the frequency was set to 0.001. The marker allele frequencies were calculated from the normal chromosomes of 66 Finnish CHH families (Sulisalo et al. 1994b). Heterogeneity was tested using the A-test as implemented in program HOMOG (Ott 1991).

Results and discussion

Nine potentially informative families were included in the linkage analysis (families 1–9). The distribution of

Table 1 Two-point lod scores between the CHH gene and three nearest marker loci in nine CHH families for which neither Finnish nor Amish ancestors are known

Locus	θ							
	0.0	0.001	0.01	0.05	0.1	0.2	0.3	0.4
D9S165	2.20	2.20	2.13	1.85	1.51	0.93	0.45	0.12
D9S163	3.23	3.22	3.14	2.75	2.28	1.38	0.64	0.16
D9S50	2.63	2.62	2.55	2.23	1.84	1.13	0.55	0.15

marker alleles in these families is shown in Fig. 1. The two-point lod scores between the CHH gene and three closest marker loci are shown in Table 1. No recombinations were detected between the CHH gene and markers in any of the informative meioses, suggesting genetic homogeneity of CHH in various populations. The highest lod score of 3.23 at a zero recombination fraction was detected between the CHH gene and D9S163. The maximum lod scores for D9S165 and D9S50 reached 2.20 and 2.63, respectively. The maximum multipoint lod score of 4.10 was obtained at D9S163. No evidence of heterogeneity was found (HOMOG), although the sample size was limited and all meioses were not fully informative for all markers studied. The genetic homogeneity of CHH validates the use of closely linked markers for prenatal diagnosis in families from various populations.

We have previously observed a statistically significant association between the CHH gene and alleles at D9S163 in both Finnish and Amish families (Sulisalo et al. 1994a, b). In Finnish families, CHH is associated with allele 3, and in Amish families, with allele 6. Of the 32 CHH chromosomes studied here, 14 carried allele 6, 10 carried allele 3, seven carried allele 4, and one carried allele 2 at D9S163. Alleles 3, 4, and 6 are common in the normal chromosomes of the Finnish and Amish CHH families, and in the Centre d'Etude du Polymorphisme Humain (CEPH) reference families (frequencies vary from 0.2 to 0.4; data not shown). Among the Finnish chromosomes, allele 3 is the most common (41%) and alleles 4 (33%) and 6 (19%) the second and third most common (Sulisalo et al. 1994b). Among the Amish and the CEPH families, however, the most common allele is 4 (43% in both series) and alleles 3 and 6 are the second and third most common (Sulisalo et al. 1994a; CEPH data not shown). As CHH is associated with a common allele at D9S163 among both the Finns and the Amish, no definitive conclusions can be drawn about the origin of the CHH mutations in the families studied here. However, as most of the latter patients are heterozygous for alleles at D9S163, it can be concluded that either there are many different CHH mutations and a CHH mutation is a more common occurrence than has been assumed, or only a few mutations exist but recombinations or mutations at markers have changed the original marker alleles. Characterization of the gene will be required to determine whether a single or different CHH mutations are responsible for the disease in various populations.

Acknowledgements We thank Sophie Marc (Genethon, Paris, France) for sharing the allele frequency data on D9S163 in CEPH families. Maryann Priore and Daniel Cohn (Cedars-Sinai Medical Center, Los Angeles, USA), and Judith Hall (British Columbia Childrens Hospital, Vancouver, Canada) are acknowledged for collaborative help. This study was financially supported by the March of Dimes Birth Defects Foundation (#6-FY92-0181), the Sigrid Jusélius Foundation, the Academy of Finland, and the Paulo Foundation. Part of the study was carried out at the Folkhälsan Institute of Genetics.

References

- Burgt I van der, Haraldsson A, Oosterwijk JC, Essen AJ van, Weemaes C, Hamel B (1991) Cartilage hair hypoplasia, metaphyseal chondrodysplasia type McKusick: description of seven patients and review of the literature. *Am J Med Genet* 41: 371–380
- Hästbacka J, Chapelle A de la, Kaitila I, Sistonen P, Weaver A, Lander E (1992) Linkage disequilibrium mapping in isolated populations: diastrophic dysplasia in Finland. *Nature Genet* 2: 204–211
- Lathrop GM, Lalouel JM, Julier C, Ott J (1984) Strategies for multilocus linkage analysis in humans. *Proc Natl Acad Sci USA* 81: 3443–3446
- Lehesjoki A-E, Koskiniemi M, Norio R, Tirrito S, Sistonen P, Lander E, Chapelle A de la (1993) Localization of the EPM1 gene for progressive myoclonus epilepsy on chromosome 21: linkage disequilibrium allows high resolution mapping. *Hum Mol Genet* 2: 1229–1234
- McKusick VA, Eldridge R, Hostetler JA, Ruangwit U, Egeland JA (1965) Dwarfism in the Amish. II. Cartilage-hair hypoplasia. *Bull Johns Hopkins Hosp* 116: 232–272
- Mäkitie O (1992) Cartilage-hair hypoplasia in Finland – epidemiological and genetic aspects of 107 patients. *J Med Genet* 29: 652–655
- Mäkitie O, Kaitila I (1993) Cartilage-hair hypoplasia – clinical manifestations in 108 Finnish patients. *Eur J Pediatr* 152: 211–217
- Ott J (1991) *Analysis of human genetic linkage*, rev. ed. Johns Hopkins University Press, Baltimore, MD
- Perheentupa J (1972) Kolme periytyvää kasvuhäiriötä (in Finnish). *Duodecim* 88: 60–71
- Sulisalo T, Sistonen P, Hästbacka J, Wadelius C, Mäkitie O, Chapelle A de la, Kaitila I (1993) Cartilage-hair hypoplasia gene assigned to chromosome 9 by linkage analysis. *Nature Genet* 3: 338–341
- Sulisalo T, Francomano CA, Sistonen P, Maher JF, McKusick VA, Chapelle A de la, Kaitila I (1994a) High resolution genetic mapping of the cartilage-hair hypoplasia gene in Amish and Finnish families. *Genomics* 20: 347–353
- Sulisalo T, Klockars J, Mäkitie O, Francomano CA, Chapelle A de la, Kaitila I, Sistonen P (1994b) High resolution linkage-disequilibrium mapping of the cartilage-hair hypoplasia gene. *Am J Hum Genet* 55: 937–945
- Weissenbach J, Gyapay G, Dib C, Vignal A, Morissette J, Millasseau P, Vaysseix G, Lathrop M (1992) A second-generation linkage map of the human genome. *Nature* 359: 794–801
- Wilkie PJ, Krizman DB, Weber JL (1992) Linkage map of human chromosome 9 microsatellite polymorphisms. *Genomics* 12: 607–609