

**UNIVERSITY OF
LEADING
THE WAY
WESTMINSTER** 

WestminsterResearch

<http://www.westminster.ac.uk/research/westminsterresearch>

Reliability enhanced EV using pattern recognition techniques

Mohammad Samie¹
Amir M.S Motlagh²
Alireza Alghassi¹
Suresh Perinpanayagam¹
Epaminondas Kapetanios²

¹School of Applied Sciences, Cranfield University

²Faculty of Science and Technology, University of Westminster

This is a copy of the author's accepted version of a paper subsequently published in the proceedings of 2014 IEEE International Electric Vehicle Conference (IEVC). IEEE, pp. 1-8. It is available online at:

<http://dx.doi.org/10.1109/IEVC.2014.7056199>

The WestminsterResearch online digital archive at the University of Westminster aims to make the research output of the University available to a wider audience. Copyright and Moral Rights remain with the authors and/or copyright owners.

© 2014 IEEE. Personal use of this material is permitted. Permission from IEEE must be obtained for all other uses, in any current or future media, including reprinting/republishing this material for advertising or promotional purposes, creating new collective works, for resale or redistribution to servers or lists, or reuse of any copyrighted component of this work in other works.

Whilst further distribution of specific materials from within this archive is forbidden, you may freely distribute the URL of WestminsterResearch: (<http://westminsterresearch.wmin.ac.uk/>).

In case of abuse or copyright appearing without permission e-mail
repository@westminster.ac.uk

Reliability Enhanced EV Using Pattern Recognition Techniques

M. Samie, S. Perinpanayagam, A. Alghassi
Integrated Vehicle Health Management Centre
Cranfield University
Bedford, England
m.samie@cranfield.ac.uk

A. M. S. Motlagh, E. Kapetanios
Faculty of Science and Technology
University of Westminster
London, England
w1418752@my.westminster.ac.uk

Abstract— The following paper will contribute to the development of novel data transmission techniques from an IVHM perspective so that Electrical Vehicles (EV) will be able to communicate semantically by directly pointing out to the worst failure/threat scenarios. This is achieved by constructing an image-based data communication in which the data that is monitored by a vast number of different sensors are collected as images; and then, the meaningful failure/threat objects are transmitted among a number of EVs. The meanings of these objects that are clarified for each EV by a set of training patterns are semantically linked from one to other EVs through the similarities that the EVs share. This is a similar approach to well-known image compression and retrieval techniques, but the difference is that the training patterns, codebook, and codewords within the different EVs are not the same. Hence, the initial image that is compressed at the transmitter side does not exactly match the image retrieved at the receiver's side; as it concerns both EVs semantically that mainly addresses the worst risky scenarios. As an advantage, connected EVs would require less number of communication channels to talk together while also reducing data bandwidth as it only sends the similarity rates and tags of patterns instead of sending the whole initial image that is constructed from various sensors, including cameras. As a case study, this concept is applied to DC-DC converters which refer to a system that presents one of the major problems for EVs.

Keywords—*Connected Vehicle; Electrical Vehicle; Reliability, Image Processing; Vehicle Health Management.*

I. INTRODUCTION

Next generation of intelligent transportation system (ITS), that promises connected vehicles [1], focus on localized Vehicle-to-Vehicle (V2V), Vehicle-to-Infrastructure (V2I), and Vehicle-to-Device Systems (V2X) to support safety, mobility and environmental applications using well established standards such as vehicle Dedicated Short Range Communications (DSRC), and Wireless Access for Vehicular Environments (WAVE). Using these standards, a number of communication systems have been already established for transmitting/receiving reliability and safety information among huge number of different vehicles, and related systems. Vehicular Ad hoc Network (VANET) [2]; and wireless MAC techniques (LAN & 3G) [3] are those widely addressed by other researchers. Nevertheless, each has its own advantages and disadvantages, yet none of them are constructed from a

vehicle health management perspective, considering that the nature of information arises from threats in a challenging driving environment.

Improving the reliability and safety of electrical vehicles (EV) require considering various issues coming from either EV's components degradation (or failure), challenging environment where threats may come from obstacles, other EVs, pedestrians, and communication failure as lots of different systems would be required to communicate with one another. Additional care should also be directed towards resilient trustworthy cyber-physical systems as EV's electronics may be affected by hackers, hardware/software Trojans [4]. These may be addressed by utilizing an Integrated Vehicle Health Management (IVHM) that intends to employ Condition Base Management (CBM) to preserve and enhance the reliability and safety of systems in critical environment [5]. Success of IVHM relies on development of prognostics, diagnostics models to deal with EV's own failure; and also, event forecasting models to deal with threats coming from other EVs and threats coming environmental hazards.

Remote Vehicle Diagnostics [6], and Connected Vehicle Diagnostics and Prognostics [7] are two concepts that have been proposed for enhancing connected vehicles with IVHM solutions. In the first one, the vehicles sensor data is transmitted to remote computers through wireless communication. Then, vehicle fault diagnostics is performed remotely while the vehicle is being driven. On the other hand, the second one continuously collects engineering data to provide vehicle building history and repair history. Source of data can be from on-road vehicles, vehicle assembly lines, vehicle repair shops, and etc. In any case, wide range of various sensors is employed to monitor current states of EV; such as voltage, current, temperature sensors as well as cameras, infrared, and etc. Additionally, in connected vehicle, it is required that different sensors of different vehicles talk to one another simultaneously, that in turn, requires numbers of communication channels, antennas and wireless devices utilised in a form of multi-input multi-output communication system (MIMO). Hence, development of sufficient communication system that could meet requirements of reliability and safety of connected vehicle has been an active challenge and research since the idea has been proposed [8].

In many image processing applications such as TV transmission, size of data to store, transmit, and process is often one of the most important challenge that need to be taken into account. Data compression and retrieval techniques are employed to reduce the bit rate for transmission and data storage while maintaining an acceptable level of quality and fidelity. Vector Quantization (VQ); for instance, is one of the most powerful techniques comprised from four steps: vector formation, training set selection, codebook generation, and quantization [9][10]. Using this technique, a codebook (or bank of codewords) is created by iterative clustering algorithms, and then the address of the codeword that presents the highest similarity with the data is provided for further processes. Applying this technique to applications in IVHM-enhanced system may open a new avenue for reliability and safety of connected vehicles. In a more intelligent communication system to transmit reliability information, it is not required for the data transmitted to have the highest accuracy as they are measured; instead, EVs can communicate to one another semantically based on the worst scenarios of risks that they may face with in the real operation. For the purpose of IVHM, EVs communicate with each other by just pointing out to the patterns of risk instead of having to transmit the entire sensor data.

This paper intends to present a radically novel system that enables EVs to communicate with one another semantically using enhanced pattern recognition techniques. This is particularly suitable for IVHM applications, seeing how much the current situation of EV is similar to a number of risky situations that EVs have already been trained with. It employs existing similar attributes shared among a number of different systems and events by presenting a similarity-based IVHM-enhanced vehicle system using image processing and pattern recognition techniques to help us measure degradation, and performance amongst different EV systems. So it overall enhances connected vehicles with the capability to learn from events and actions experienced; and therefore make conforming decisions based on measuring the similarities of current event with those previously experienced while also mimicking expert knowledge from professional drivers. An advantage of this approach is to establish and generalise a body language-like communication system out of a number of systems/EVs that in turn may improve the communication cost by reducing the vast details of messages, hence, saving us the trouble of transmitting/receiving the initial pure data sensed by sensors.

The next section shall describe the reliability information from IVHM's perspective regarding prognostics, diagnostics and event forecasting features. The Development of an image-based data along with utilising a similarity-based communication system will be covered in Section 3 and 4. Section 5 covers the case study of DC-DC power converter via developed algorithms as well as the details of the simulations and validation approaches stated in the sub-sections. Lastly, the conclusion is covered in section 6.

II. RELIABILITY INFORMATION FROM IVHM PERSPECTIVE

To properly address IVHM features (regarding to prognostics, diagnostics and forecasting features) [5], it is

necessary to integrate many sensors to the system and monitor the performance of critical components. The vast amount of information monitored by these sensors should be collected and sorted into relevant profiles; and then, processed to create a clear distinction between both health states of the vehicle such as the degradation of the components and systems (i.e., breaks); and performance of pilot/driver while driving in a challenging environment (such as vehicle to vehicle distance) [11]. Anyhow, regardless of the vehicles/components manufacturer; or what the driving conditions are, similar components do present similarities in their degradation profiles. The same way similarity may be identified in patterns of threats that may lead to collision, etc. For instance, Fig. 1 shows IGBT run to failure data for four different IGBTs that can be used as power switches in EV's power converter. This data is too noisy and needs to be filtered, but still there are a number of states and similar failure patterns that can be seen in the data. These states refer to cracks or wires that were lifted up due to degradation mechanisms [12]. The following failure patterns can be modelled with equation 1, Fig. 2:

$$I_0 = \sum_i (P_{i1} + P_{i2} (1 - \exp(-(t - P_{i3}) / P_{i4}))) \quad (1)$$

where I_0 is the current of the load, t is the time index (when the sample has been taken), P_{i1} to P_{i4} are parameters which define patterns used for instance by the particle filter estimation algorithm, and $i = \{1, 2, \dots, 6\}$ is the number of clusters detected in the IGBT's failure data using the K-Means and Silhouette clustering tools of MATLAB.

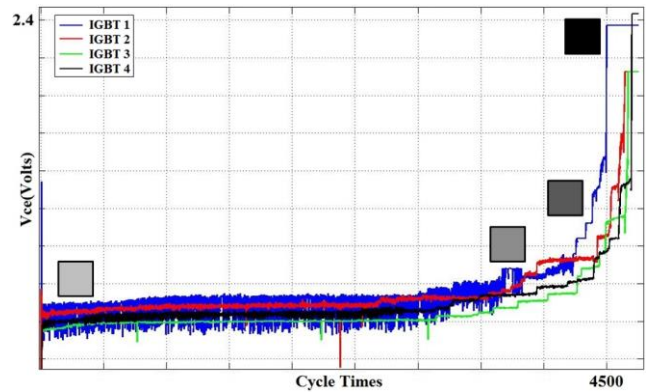

Fig. 1. Run to failure data for four different IGBTs.

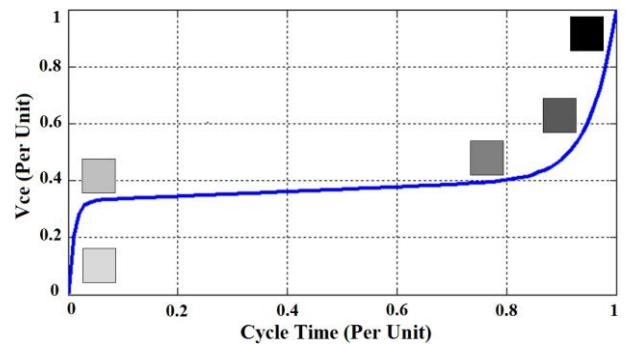

Fig. 2. Normalised degradation model for IGBT.

Similarity measurement can be used to conduct prognostics and forecasting solutions via utilising similarity-based IVHM systems. At the highest system level, a System-Level Reasoning (SLR) can be developed to at least provide the system with essential capabilities to potentially link similar systems by assigning the system prognostics with a System Integrated Prognostic Reasoner (SIPR) [5][11]. A Vehicle Integrated Prognostic Reasoner (VIPR), for instance, is a NASA funded effort for developing the next generation VLRS. A typical functional module within the SLR is a System Reference Model. This System Reference Model divides the system into partitions; and provides the necessary relationships between subsystems for the inference process. This partitioning enables the inference engine to reuse and link the same prognostic models to multiple subsystems and further minimize certification and qualification costs, just from using this similarity concept [5][11]. Efforts previously made towards the creation of reference engine models highlight the value added towards looking into patterns of reliability data, failure mechanisms, and degradation process to develop similarity-based IVHM system. Yet such a process requires the creation of degradation profiles for each component and event, development of prognostics, diagnostics and forecasting models, as well as techniques to deal with uncertainties, and reasoning, followed by conducting similarity measurements.

Numbers of various techniques have been suggested in the literatures for development of prognostics [7][13]; diagnostics [14] and forecasting models [15]. Scientific approaches for both system prognostics and threat forecasting are the same; however, the sources of failure and threats are different. Although, prognostic approaches can also be employed in system diagnostics, but the main challenge occurs in situations where the fault was sudden, which means prognostics will fail to make a viable prediction. Due to IVHM needs, requirements to automotive diagnostic protocols is increased during last few years because future vehicles are highly equipped with low power electronics in almost any equipment (even components) such as electronic fuel injection, automatic gear box, etc [13]. Having more electronic featured components and systems will require additional care toward resilient trustworthy cyber-physical systems as safety, security and privacy issues may affected by, for instance, by hackers, hardware and software Trojans [4][14].

It is impossible to provide same IVHM solutions for different systems. In fact, a key difference between the low power electronic system with high power electrical and mechanical systems is that failures are progressed rapidly and suddenly in low power electronics and VLSI devices, whereas in high power and mechanical systems, failures are developed over the time in a form of degradation to the point of malfunction. Furthermore, as components feature sizes fall, such as in CMOS transistor and micro-electrical-mechanical systems (MEMs), it seems inevitable that failure will be more common due to stochastic variability in fabrication. Random transient failure, for example in a mobile phone of the future, may be recovered by rebooting, however, raised failure rates in many every day electronic systems [16], such as a car engine electrical control unit (ECU), could be life-threatening.

Due to the nature of failure in such systems, conducting prognostics on low power electronics are not recommended; hence, a vehicle should instead be equipped with diagnostics techniques [14] such as designs in testability, self-test and along with self-healing/fault-tolerant solutions [16].

To fully cover all these issues, IVHM requires a highly reliable communication system that could provide sufficient data transmission facilities in the most cost effective way. The next sections take on the challenge of developing an effective communication system by utilising image processing and pattern recognition concepts.

III. DEVELOPMENT OF PICTURE-BASED DATA

Consider a system as a black box given in Fig. 3. It is comprised from number of subsystems and components with variety of different physics, topologies and functions. It is also known which ports belong to which subsystems or specific components. Features, behaviours and functions of such systems can be well understood from utilising a number of state equations and transfer functions that describe how different ports are linked to one another, and how energy is transferred from inputs to outputs. For the purpose of this paper, describing the details inside this black box is not under particular interest. Having just a number of sensors that fulfil the tasks of monitoring the performance of a system (as long as they are truly distributed through subsystems and components) will provide us with enough information to monitor the right set of signals. Let's collect all the sensed values in a 2-dimension matrix while it is divided into a number of different parts, each for a specific subsystem or component, Fig. 4.

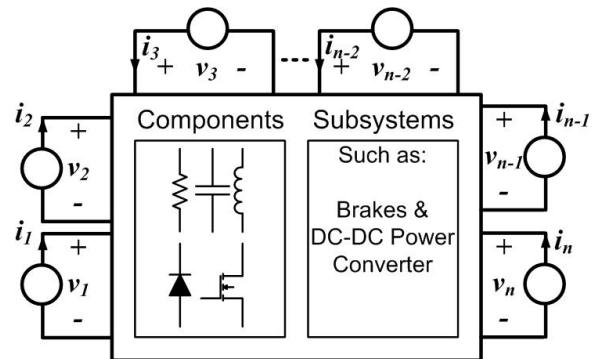

Fig. 3. System as black box with n ports and 2n sensors.

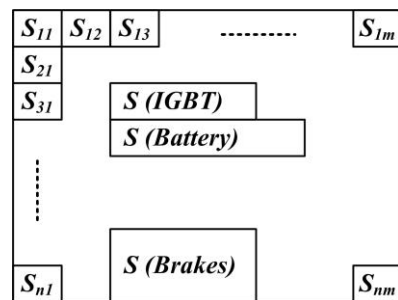

Fig. 4. All sensors of EV are collected in a 2-dimension matrix of size n.m; S represents sensor.

Size and complexity of such a matrix is dependent on the complexity of the system and the number of sensors used for monitoring, but it still continues to remain as a two-dimension matrix in the form of $A(n,m)$ where n and m refers to the size of the matrix with $m.n$ elements. As a component/subsystem of a vehicle is degraded, related values of that particular component/subsystem in matrix A are also changed and produces a 3-dimension time depended matrix as $B(n,m,s)$ where s represents sample taken from system at time t . Thus, the first initial 2-dimension matrix, $A(n,m)$ that refers to a healthy system is equal to $B(n,m,0)$ at $t=0$; and it is considered as a 2-dimension image if the values within a matrix A are seen as pixels. Any other 2-dimension matrix from $B(n,m,s)$ at given s would be a degraded form of $B(n,m,0)$ that can again be considered as an image. Therefore, $B(n,m,s)$ is a collection of 2-dimension matrices that presents a movie if we were to see 2-dimension matrices as images. Failures appear as shape and colours of objects that are changed in the movie-like system's specifications. Fig. 5 shows an example of such a movie-like system specification for circuit in Fig. 6 that is considered as a simplified part of a more complicated system. For this simplified example, voltage across capacitors and current through inductors are used as state variables. To create an image from this 4×4 matrix, we assign colours to values/pixels in the matrix while being healthy. The matrix is then turned into a set of movies which show the values that change over time as the circuit is aging, and so resulting to the colours of the pixels to also change, Fig. 5.

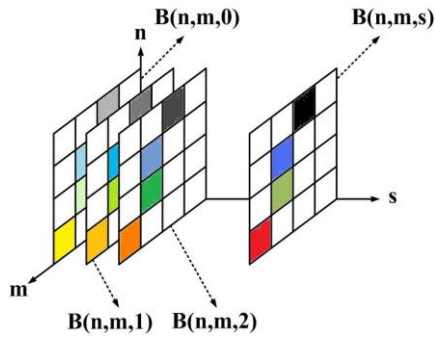

Fig. 5. Example of 3-dimension time dependent matrix for circuit in Fig. 6.

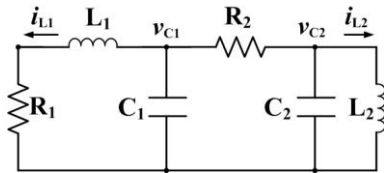

Fig. 6. Example of circuits with 4×4 matrix.

IV. PRINCIPLE OF SIMILARIY-BASED COMMUNICATION SYSTEM

Research on the feasibility of similarities among a wide range of different vehicles (including components and systems that they are comprised from) would further help in building novel data transmission techniques. This is conducted by constructing similarity-based data communication systems in which the data that is monitored by a vast number of different sensors are collected as image; and then, the meaningful,

similar objects (as patterns) from the image itself are transmitted by means of their similarities with a number of training patterns. In fact, EVs pilots are initially trained with a number of patterns within an offline process. Then during the real operation, the constructed image from sensor data is compared against the training patterns within an EV as a transmitter. The result is number of similarity rates and tags that are transmitted to other EVs along with its speed and location of the transmitting EV. At the receiver's end, retrieving data is processed by fusing patterns addressed by tags under their related similarity rates, even though the training patterns of EVs are slightly different from one another. Training pattern of different EVs are not exactly the same since different EV systems have different subsystems and components involved, so their related images constructed from sensor data would be different.

If EVs are supposed to share reliability information and their failure/threat experience, then their similarity in topology, components, functions and failure mechanisms might be well understood and linked to one another based on their shared similarities. This requires the development of unified models for all different types of the same component; for instance, a unified model for all different DC-DC converters as described in [17]; and then, they can be link to one another through their similarities via the created unified model. Hence, the overall sensor data image of EV is constructed from a number of objects related to the unified models, each for a component or subsystem of EV. Although the sensor data images are not the same, but the objects which images are comprised from are still meaningful due to their connections through unified models. This causes that the retrieved data in an EV to not exactly be the same as what has been transmitted from another EV; but still be meaningful enough to distinguish what sorts of risks, an EV as a transmitter is referring to. In comparison to the real world; people from different languages can still communicate using body-language.

Success of such a process requires a number of offline processes to construct system similarity, training pattern and all related data fusing algorithms, Fig. 7; and online data fellow, Fig. 8, that both jointly lead to designing the EV's pilot. The offline process is started from conducting various tests and simulations to collect relevant sensory data from the EV as its being accelerated toward degradation, failure, and threats. Wide range of different components, equipment and subsystems from different manufacturers as well as events that may lead to traffic or accident should be considered under different working conditions. The collected data then should be filtered (to reduce noise) followed by employing feature extraction and classification techniques to identify the best set of patterns that best describes any failure or threat that an EV may be faced with. This is what is used as initial training patterns in the offline process and should be stored in the pattern bank considering that the patterns are addressed by tags (like codebook and codewords). Later in a real time operation, the patterns are adjusted to intelligently reconstruct data images monitored from EV's real scenarios.

The communication concept presented here is similar to the data compression and retrieval techniques; however, the

key difference is that the retrieved data can be different from the initial data (that is compressed) depending on the similarity of the EVs systems. Still the objects in both initial and retrieved data have the same meaning for both systems.

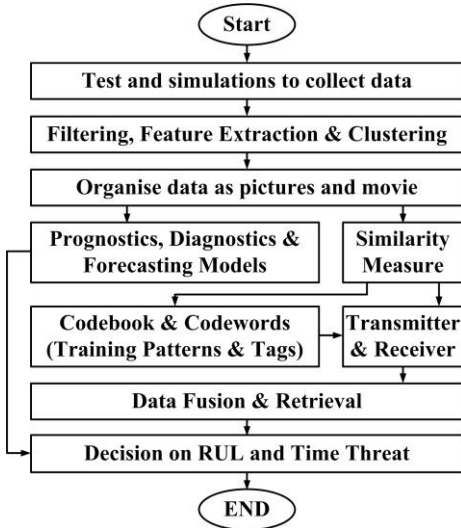

Fig. 7. Simplified flow chart that summarises offline process.

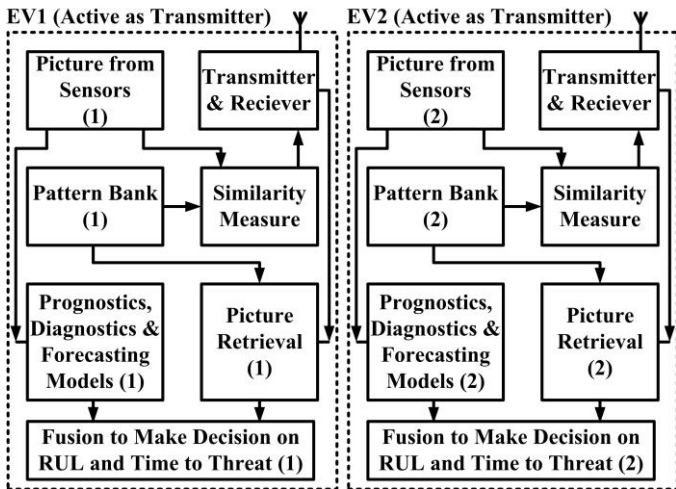

Fig. 8. Simplified data flow that summarises real time process.

Hence, the detected similarities that are used for semantic vehicle communication can also be employed to enhance the EV's reliability and safety by conducting a number of similarity-based procedures in vehicle health management through enabling connected vehicle with Vehicle Integrated Prognostic Reasoner and vehicle inference engines.

The development of such an IVHM-enhanced connected vehicle system requires constructing novelties in CAD design and system middleware to assist designers to build a system on such a platform that 1) increases the level of similarity in a multi-agent system platform; 2) enables communication and management of data in distributed applications so that specifications and features of different systems (as data) could be applied to one another through their similarities. With such a feature, EVs would be able to estimate and predict their own

health states as well as threats that may arise from other surrounding EVs. This paper contributes in feasibility of such a communication system through a case study regarding the meaning of objects of Cuk converter in an EV for its dual circuit in another EV that is presented in next section.

V. CASE STUDY: DC-DC CONVERTER FOR EV

A. DC-DC Converter

EVs use a category of power converters known as DC-DC converter to change the level of voltage under source of direct current (DC) [18]. Energy is temporarily stored; and then, released at a different level of voltage. This technique is employed by any topology of EV power supply to interface the fuel cell, the battery or the super-capacitors module to the DC-link. Fig. 9 shows as an example of electric vehicle drive system where all three DC-DC converters have been used. Of course, at least one DC-DC converter is needed under any power supply configuration [18].

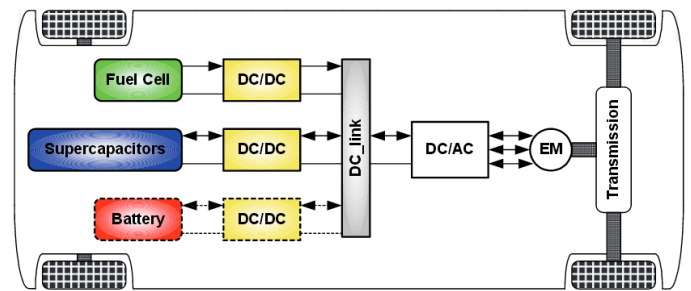

Fig. 9. Electric vehicle drive system [18].

As a result of automotive constraints, the power converter structure has to be reliable, lightweight, small volume, have high efficiency, low electromagnetic interference and low current/voltage ripple. A wide variety of DC-DC converters topologies have been published by other researchers [17][19]. In regards to the converters, it is shown that circuit transformations can be used to unify the basic converters, ultimately showing that other converters are derivable transformation topologies of the basic converter [17]. Hence, a unifying model is what we might be able to benefit from in mapping failure pattern of a converter to the basic unified models; and ultimately, creating similarity-based prognostics models. It is shown that prognostics and failure pattern of a Cuk converter can be applied to its dual circuit [20].

Nowadays, it is well understood that one of the most vulnerable component that current EVs' are suffering from their failures is IGBT that brings limitation on safety and economic issues of EVs [13]. Alghassi et al has discussed different failures mechanisms related to IGBT and they have also presented prognosis model for the dominant failure at a component level in [21][22]. From system level prognostics, changes in the energy transfer in Cuk converter can be used to detect earlier sign of degradation and failure. In fact, as a result of degradation, energy is not sufficiently transferred in the circuit [20].

B. Development of Image-Based Reliability Information for Cuk Converter

This section provides an example of image-based reliability information for the Cuk converter and its dual converter. To do this, we set Cuk converter given in Fig. 10-a, and its dual converter in Fig. 10-b using OrCAD 16.6 while IGBTs are modelled to be failed with the same failure trend as given in Fig. 1. This in turn adds degradation to the simulations. Boxes in this Fig. 1 present that colours of pixels are changed as value of v_{ce} (voltage across collector-emitter of IGBT) is changed due to degradation.

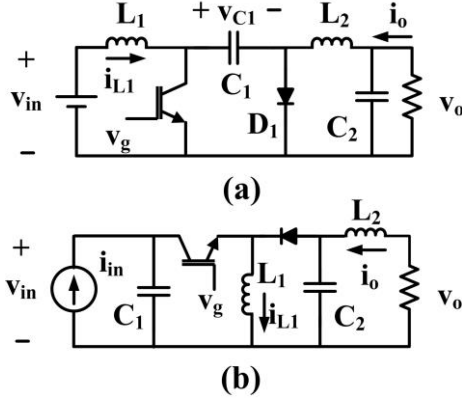

Fig. 10. DC-DC Cuk Converter.

At first, the components of the circuits are set to be in a good condition. Then as soon as the time step for the circuits under simulation is increased, the values of the components are changed by using a series of values provided within the degradation profile for the new time step. Voltages of different nodes, and current through the branches, such as v_1 , v_2 , v_o , i_1 , i_2 , i_o , are measured at each time step phase. We also assign colours to values of these signals to map values to pixels which create image and movie-like system specifications based on the matrix given in Fig. 11.

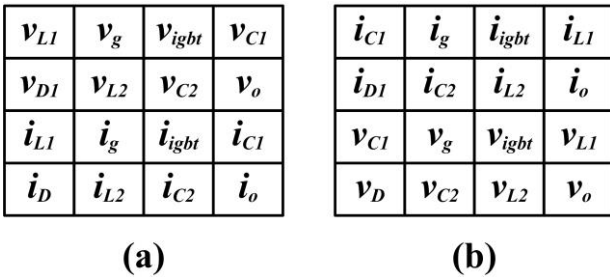

Fig. 11. Signals of Cuk sorted in the picture as pixels. (info together become a picture)

The measured signals are then transferred to MATLAB to collect suitable on-state and off-state values from signals of IGBTs that are v_{igbt} and i_{igbt} in the Fig. 11. v_{igbt} is the voltage across collector-emitter when IGBT is switched on (on-state mode) whereas i_{igbt} is current through collector if IGBT when it is switched off. Hence, voltages and currents have different sampling time, the same for other components. These values are sorted in the matrix, Fig. 11, in such a way that the duality principle in electrical systems is fulfilled. Fig. 11-a is matrix for Cuk converter (Fig. 10-a); and Fig. 11-b is organized with

dual values of Cuk converters which in turn presents matrix of a circuit that is exactly in a duality relationship with Cuk converter (Fig. 10-b). While values in this matrix are changed due to degradation, colours of pixels are also changed and create different images and movies.

C. Development of Pattern Bank

To construct a pattern bank, Vector Quantization (VQ) that is a powerful technique applied for the low bit rate source coding, and data compression is employed. VQ maps a group of pictures into number of representatives in a finite k-D Euclidean space. VQ has been widely used for data compression, lossy data correction, pattern recognition, density, estimation, and clustering. Numbers of different algorithm have been suggested [9]. Here an algorithm named Linde-Buzo-Gray (LBG) is employed [9]. Using this algorithm, initial pictures in the degradation profile of Cuk converter are compressed and representatives are collected in a codebook. Through various simulations using MATLAB, it has been realised that the pictures given in Fig. 12 can be located in the pattern bank indexed by 1 to 3 for Cuk Converter. Hence, pattern bank of EV that includes DC-DC Cuk converter would have only one image for each health state of Cuk converter (healthy, aged and failed). Similarly, the same number of images is created for its dual circuit of Cuk, but with slightly different patterns, that should be included in the pattern bank of EVs that include the dual circuit of Cuk. Then, the indexes of these representatives from EV with Cuk are transmitted along with similarity measures to EVs with dual Cuk. Patterns in Fig. 12 are created using IGBT's failure model, equation 1.

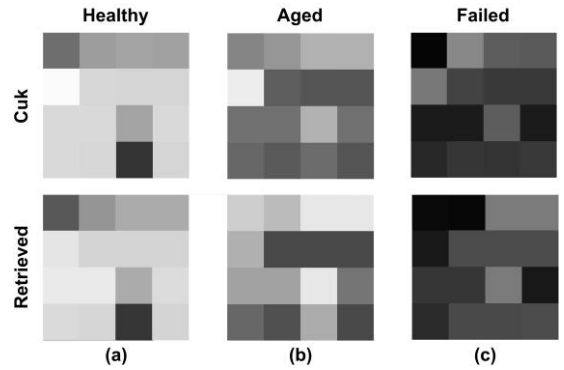

Fig. 12. Initial and retrieved sensor data image of Cuk.

D. Similarity Measure and Data Retrieval

Various techniques for measuring similarities in images have been addressed in [23]. Ref [24] also describes techniques to retrieve images using VQ which is the technique that we used for identifying the pattern bank (the codebook). Considering pattern bank with three patterns addressed with $j=1, 2, \text{ and } 3$; state of the Cuk converter sampled with k known as query picture (Q), and pixels of pictures are indexed by $i=1, 2, 16$. The following equation is used in this paper to measure the similarity:

$$S_{kj} = \sum_i (W_i | (P_{ij} - Q_i) |) \quad (2)$$

where S_{kj} indicates the similarity distance of sample k with pattern j , w is weight of pixel i , P is the pattern j from pattern bank, and finally Q is the query image. Tag of the most similar patterns along with their similarity measures are selected at transmitter side; and then, these are used for retrieving the information (reconstruct the image) at receiver. More complicated methods have been discussed in [24]; however, the equation 2 or even techniques introduced by Idris [25] are accurate enough for the simple case-study chosen here.

E. Validation

To validate the proposed technique, pattern banks have been created using IGBT degradation model given in equation 1 (Fig. 2) that construct training patterns for Cuk converter as in Fig. 12; and the same way another set of patterns for dual circuit of Cuk. Then, the four IGBT degradation profiles shown in Fig. 1 have been used for validation. Our experiments conducted by MATLAB show that the proposed technique presents sufficient level of accuracy while the following steps have been processed during the validation:

- 1- Constructing two pattern banks (codebooks, one for EV with Cuk, and the other for EV with dual circuit of Cuk) using failure model of IGBT, equation 1; and VQ compression technique that generate codebooks.
- 2- The two sets of patterns created in step 1 are sustained in pattern banks of two EVs (one set in each EV); and addressed with related tags.
- 3- Similarity measure is conducted using equation 2 at transmitter side; and the most similar pattern from the pattern bank is selected.
- 4- Tag of the most similar pattern along with the similarity measure value is transmitted.
- 5- At receiver side, the received tag is used to address a pattern in the bank; and then query image is retrieved by encoding the received information using the similarity measure.

Fig. 13, 14, and 15 measures the similarity of initial image with the retrieved one (Fig. 12) using Norm, Mean Absolute Error (MAE), and Mean Squared Error (MSE) performance functions for whole duration life of circuits are shown in Fig. 13. Fig. 13-a shows examples of measuring similarity during when the whole image (matrix) of Cuk's dual circuit at receiver is compared with the image at transmitter whereas other figures are for situations that signals from diodes are excluded (Fig. 13-b), or pattern is just comprised from signals of IGBTs (Fig. 13-c). In these figures, the highest and lowest similarities have values of 0 and 1, respectively. Figures clearly show that similarity is higher when systems are healthy or at early stage of failure so they can successfully share their reliability information.

We just applied simple similarity measures to prove the proposed concept. Clearly, better similarity measurement concepts can be implemented if the patterns and objects in the images are well described and more complicated pattern recognition and object detection techniques were also employed. Patterns that reflect system failure can be known as

failure objects. This means, the matrix of a circuit, and so movie-like system specification of that circuit could be assigned to even other circuits that have different topologies; for instance, boost or buck DC-DC converters. Hence, it could be possible to make a viable decision on the health state of a circuit (Cuk for instance) from other circuits (boost for instance), if patterns and failure objects of them are well understood from using this similarity concept.

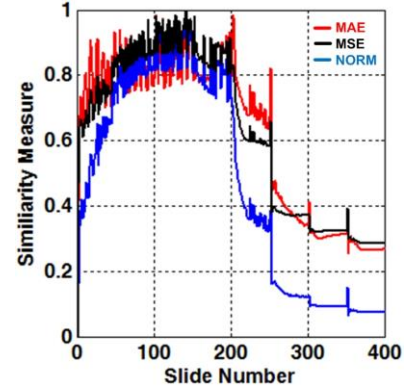

Fig. 13. Similarity measure of whole image.

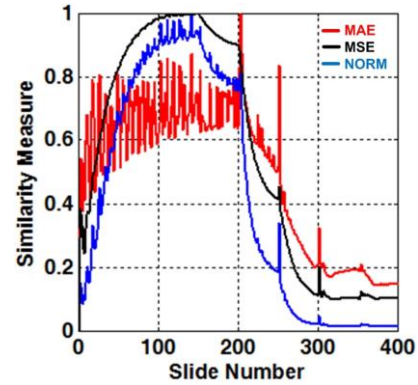

Fig. 14. Similarity measure when some components are excluded.

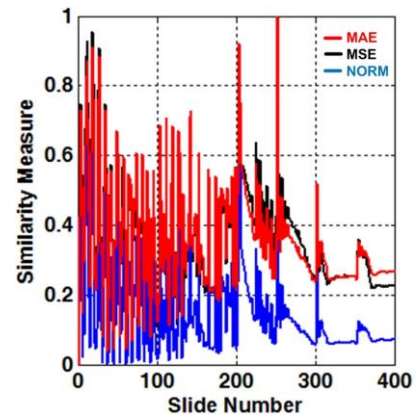

Fig. 15. Similarity measure when only IGBT is considered.

VI. CONCLUSION

In conclusion, this paper illustrates how image processing techniques can be used to establish a semantic communication

system from an IVHM perspective for applications in connected vehicles. Using a DC-DC case study, it is shown that failure objects of a Cuk converter in an EV can be semantically meaningful for other EVs even though their converters are constructed by dual topology of Cuk.

The EVs sensor data are collected as image, and then the EV's failures and threats are turned into objects within the sensor data image. Having EVs with different structures and components results in different sensor data images, but still the failure objects of components and threat objects of driving situations present semantic meaning through the similarities that the components, systems and events share among different EVs. This semantic knowledge is employed for building novel communication system to which EVs can communicate with each other just by pointing out semantically the worst risky situations (failure and threats) instead of transmitting and receiving the initial large sensor data.

The proposed communication system that is specifically designed to meet the IVHM requirements of EV in order to increase the safety and reliability is justified with a simple case study of DC-DC converter. Further research is carrying out to extend the hypothesis and concepts for more complicated systems including various topologies of converters, batteries and brakes as well as driving scenarios concerning accident and traffic management.

ACKNOWLEDGMENT

The authors would like to sincerely thank Professor C Mark Johnson and Dr Paul Evans from the Power Electronics, Machines and Control Group, University of Nottingham for the contribution of failure data of the IGBTs and the power cycling test rig configuration.

REFERENCES

- [1] N. Lu, N. Cheng, N. Zhang, and et al.; "Connected Vehicles: Solutions and Challenges", IEEE Internet of Things Journal, Vol. 1, NO. 4, August 2014, pp. 289-299.
- [2] A. Kumar, M. Sinha; "Overview on vehicular ad hoc network and its security issues," IEEE International Conference on Computing for Sustainable Global Development (INDIACom), 5-7 March 2014, pp. 792-797.
- [3] R. A. Saeed, M. A. Abakar, and et al.; "Design and Evaluation of Lightweight IEEE 802.11p-based TDMA MAC method for Road Side-to-Vehicle Communications," International Conference on Computer and Communication Engineering (ICCCE 2010), 11-13 May 2010, Kuala Lumpur, Malaysia.
- [4] P. J. Jin, C. M. Walton, and et al., "Analyzing the Impact of False-Accident Cyber Attacks on Traffic Flow Stability in Connected Vehicle Environment," International Conference on Connected Vehicles and Expo (ICCVE 2103), pp. 616-621.
- [5] I. K. Jennions, "Integrated Vehicle Health Management Perspectives on an emerging field," SAE International, Warrendale, pennsylvania, USA, pp. 100-110, 2011.
- [6] S. You, M. Krage, and L. Jalics, "Overview of remote diagnosis and maintenance for automotive systems," SAEWorld Congress. Detroit, Michigan, April 11-14, 2005.
- [7] Y. Zhang, G. W. Gantt, and et al.; "Connected Vehicle Diagnostics and Prognostics, Concept, and Initial Practice," IEEE Transactions on Reliability, VOL. 58, NO. 2, June 2009, pp. 286-294.
- [8] K. Pu; "The future of wireless application development for a connected vehicle," IEEE Conference Proceedings Northcon, Seattle, WA, 21 Oct. 1998, pp. 104-106.
- [9] M. Mittal, R. Lamba; "Image Compression Using Vector Quantization Algorithms: A Review," International Journal of Advanced Research in Computer Science and Software Engineering, Volume 3, Issue 6, June 2013, pp. 354-358.
- [10] T. C. Lu, C. Y. Chang; "A Survey of VQ Codebook Generation," Journal of Information Hiding and Multimedia Signal Processing, Volume 1, Number 3, July 2010, pp. 190-203.
- [11] I. K. Jennions, "Integrated Vehicle Health Management The Technology", SAE International, Warrendale, pennsylvania, USA, 2013.
- [12] H. K. Tseng, M. L. Wu; "Electro-Thermal-Mechanical Modeling of Wire Bonding Failures in IGBT," 8th International Microsystems, Packaging, Assembly and Circuits Technology Conference (IMPACT), 2013, pp. 152-158.
- [13] B. Ji, V. Pickert, and et. Al.; "In Situ Diagnostics and Prognostics of Wire Bonding Faults in IGBT Modules for Electric Vehicle Drives," IEEE Transactions on Power Electronics, Vol. 28, No. 12, Dec. 2013, pp. 5568-5577.
- [14] C. Susikumar, R. Agrawal, and et al.; "Built in Self-Test for Fault Tolerant Real Time Invehicle Networks through Automotive Diagnostics," International Conference on Emerging Trends in Networks and Computer Communications (ETNCC), 2011, pp. 379-382.
- [15] M. A. S. Kamal, J. I. Imura, and et.al; "Smart Driving of a Vehicle Using Model Predictive Control for Improving Traffic Flow," IEEE Transactions on Intelligent Transportation Systems, Vol. 15, No. 2, April 2014, pp. 878-888.
- [16] M. Samie, G. Dragffy, and et al.; "Novel Bio-Inspired Approach for Fault-Tolerant VLSI Systems," IEEE Transactions on Very Large Scale Integration (VLSI) Systems, Vol 21, No. 10, Oct. 2013, pp. 1878-1891.
- [17] B. W. Williams; "Generation and Analysis of Canonical Switching Cell DC-to-DC Converters". IEEE Transactions on Industrial Electronics, VOL. 61, NO. 1, January 2014, pp. 329-346.
- [18] Monzer Al Sakka, Joeri Van Mierlo and Hamid Gualous; "DC/DC Converters for Electric Vehicles," Published: September 12, 2011 under CC BY-NC-SA 3.0 license, online: <http://www.intechopen.com/books/>.
- [19] W. Yu, and J. S. Lai; "Ultra High Efficiency Bidirectional DC-DC Converter With Multi-Frequency Pulse Width Modulation," Proceedings of APEC 2008 23rd Annual IEEE Conference and Exposition on Applied Power Electronics, pp. 1079-1084, Feb. 24-28, 2008.
- [20] Samie M., Motlagh A. M. S., Alghassi A., and et. al., "Principle of Duality on Prognostics", International Journal of Advanced Computer Science and Applications, Vol. 5, No. 6, 2014, pp. 43-52.
- [21] A. Alghassi, S. Perinpanayagam, I. K. Jennions; "Prognostic capability evaluation of power electronic modules in transportation electrification and vehicle systems", IEEE, 15th IEEE Conference on Power Electronics and Applications (EPE), 2-6 Sept. 2013, 9 pages.
- [22] A. Alghassi, S. Perinpanayagam, I. K. Jennions; "A simple state-based prognostic model for predicting remaining useful life of IGBT power module", IEEE, 15th European Conference on Power Electronics and Applications (EPE), 2013, 7 pages.
- [23] A. Goshtasbi; "Image Registration: In Principles, Tools and Methods," Springer London, Chapter 2: Similarity and Dissimilarity Measures, 2012.
- [24] P. Karink, N. Shahane; "A survey on Content based Image Retrieval using Vector Quantization," International Journal of Computer Applications, 2013, pp. 18-22.
- [25] F. Idris and S. Panchanathan; "Storage and Retrieval of Compressed Images," IEEE Transactions on Consumer Electronics, pp. 937-941, Aug. 1995.