

**WestminsterResearch**

<http://www.westminster.ac.uk/westminsterresearch>

**Multiplier Free Implementation of 8-tap Daubechies Wavelet  
Filters for Biomedical Applications  
Eminaga, Y., Coskun, A. and Kale, I.**

This is a copy of the author's accepted version of a paper subsequently published in the proceedings of the *IEEE New Generation of Circuits and Systems Conference*, Genova, Italy 7 to 9 Sep 2017.

It is available online at:

<https://dx.doi.org/10.1109/NGCAS.2017.63>

© 2017 IEEE . Personal use of this material is permitted. Permission from IEEE must be obtained for all other uses, in any current or future media, including reprinting/republishing this material for advertising or promotional purposes, creating new collective works, for resale or redistribution to servers or lists, or reuse of any copyrighted component of this work in other works.

---

The WestminsterResearch online digital archive at the University of Westminster aims to make the research output of the University available to a wider audience. Copyright and Moral Rights remain with the authors and/or copyright owners.

---

Whilst further distribution of specific materials from within this archive is forbidden, you may freely distribute the URL of WestminsterResearch: (<http://westminsterresearch.wmin.ac.uk/>).

In case of abuse or copyright appearing without permission e-mail [repository@westminster.ac.uk](mailto:repository@westminster.ac.uk)

# Multiplier Free Implementation of 8-tap Daubechies Wavelet Filters for Biomedical Applications

Yaprak Eminaga, Adem Coskun, and Izzet Kale

Applied DSP and VLSI Research Group

University of Westminster

London, W1W 6UW, United Kingdom

Email: y.eminaga@my.westminster.ac.uk, a.coskun@westminster.ac.uk, kalei@westminster.ac.uk

**Abstract**—Due to an increasing demand for on-sensor biosignal processing in wireless ambulatory applications, it is crucial to reduce the power consumption and hardware cost of the signal processing units. Discrete Wavelet Transform (DWT) is very popular tool in artifact removal, detection and compression for time-frequency analysis of biosignals and can be implemented as two-branch filter bank. This work proposes a new, completely multiplier free filter architecture for implementing Daubechies wavelets which targets Field-Programmable-Gate-Array (FPGA) technologies by replacing multipliers with Reconfigurable Multiplier Blocks (ReMBs). The results have shown that the proposed technique reduces the hardware complexity by 40% in terms of Look-Up Table (LUT) count and can be used in low-cost embedded platforms for ambulatory physiological signal monitoring and analysis.

**Keywords**—Biomedical applications, Discrete Wavelet Transform (DWT), Reconfigurable Multiplier Blocks (ReMB), multiplierless implementation, Daubechies wavelets.

## I. INTRODUCTION

Biomedical signals are known to be non-stationary thus their analysis requires both local and spatial information in order to maintain fidelity of the signal during signal processing such as artefact removal and detection. Discrete Wavelet Transform (DWT) performs signal decomposition via translated and dilated versions of a basis function which effectively localizes signal in both time and frequency domain. DWT can be realized by two-channel quadrature mirror filter banks with lowpass filter ( $h_0$ ) and highpass filter ( $h_1$ ) as shown in Fig. 1 [1]. The multiresolution analysis is achieved by recursive application of the filter bank on the lowpass filtered output. The output from each filter is downsampled by 2 where outputs at lowpass and highpass branches are known as the approximation coefficients ( $cA_m[n]$ ) and detail coefficients ( $cD_m[n]$ ) covering spectrum below and above half sampling frequency, respectively. Fig. 1 demonstrates implementation of a three level analysis filter bank. Among wide range of wavelet families, Daubechies wavelets are popular choices where the Daubechies-4 ( $db4$ ) wavelet, with four vanishing moments and 8-taps, has been used in many different biomedical signal processing applications [2]–[4]. Daubechies wavelets lead to orthogonal filter banks in which the lowpass and highpass filters are non-symmetric with equal filter lengths, real and fixed coefficients. They are known to be maximally flat filters with dyadic coefficients that can be represented with fixed

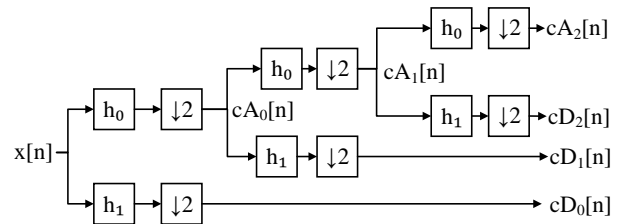

Fig. 1. Three level analysis filter bank

point arithmetic without significant loss of accuracy. Thus, they can be implemented as signed binary numbers that can reduce the hardware complexity and power consumption.

Biosignal processing tools such as filters and discrete transforms employ constant multiplications that can be implemented as shift-add operations to reduce the hardware complexity and cost of the medical systems. For example, in [5], [6], authors presented a decimation filter chain for ElectroCardioGram (ECG) acquisition systems which replaces constant multiplications with shift-add operations. DWT also employs fixed coefficient filters associated with a selected mother wavelet, hence it can benefit from shift-add network topologies. Several studies, mainly in the area of image processing, used these networks to implement wavelet filters including 5/3, 9/7 lifting-based wavelet [7]–[9], and 4- and 6-tap Daubechies filters [10]. However, to the best of author's knowledge, use of the Reconfigurable Multiplier Block (ReMB) [11] for implementing wavelet filters has not been investigated in the biomedical signal processing literature.

This paper presents a hardware efficient ReMB structure and its Field-Programmable-Gate-Array (FPGA) implementation that can be employed in time-multiplexed filter structures for wavelet analysis of biomedical signals, suitable for low-cost portable medical devices. This design is based on efficiently employing dedicated resources of FPGA as presented in [11], [12], however with an extension for taking advantage of the new FPGA technology. Section II introduces the ReMB method followed by the fixed-point  $db4$  coefficients quantization considerations, design details and implemented structure of the proposed ReMB. Section III compares the resource utilization figures of the proposed design and a general purpose multiplier. Finally, Section IV presents the drawn conclusions.

## II. METHOD

For this study, ReMB design methodology introduced in [11] is extended for recent FPGAs which replace 4 input Look-Up Tables (LUTs) with 6 input ones. A 1-bit full adder/subtractor can be implemented using the dedicated carry-chain logic and an LUT for the remaining XOR gate. The concept of reconfigurability in multiplier blocks employs a multiplexer where its output is connected to at least one input of the adder. The multiplexer can be implemented using the unused pins of the LUT that is used for an XOR gate. Demirsoy *et al.* [11] introduced an ReMB algorithm which maximizes the use of FPGA logic elements by adapting the "basic graph structure". A basic structure, as shown in Fig. 2 (a), is simply a two input adder with at least one of its inputs connected to a 2:1 multiplexer that can be implemented with a 4-input LUT. Due to the dedicated resources of FPGA, adders in basic structures are implemented as ripple-carry adders. In this work, the basic structures are modified using new 6-input LUTs which enables replacement of 2:1 multiplexers with 3:1 ones for no additional cost and are demonstrated in Fig. 2 (b). Inputs of these muxes can be connected to the input of the ReMB or to the output of another basic structure or to ground. In order to implement a set of coefficients, a number of these basic structures can be interconnected in chain (i.e. horizontally cascaded) and tree forms (i.e. inputs of a mux connected to the output of another basic structure). Number of generated coefficients at the output is dependent on basic structure topology, number of basic structures and how they are interconnected. For example, if two basic structures given in Fig. 2 (b) are interconnected (both with 3 different outputs) then the output set size is equivalent to 9 ( $3 \times 3$ ). To find a valid ReMB design for an aimed coefficient set, it is critical to realize required depth of the design, and adder depth of each coefficient. Depth of a design represents number of required cascaded stages to obtain required number of coefficients and adder depth represents the number of cascaded adders required on each path between the input and the output nodes to generate each coefficient. Thus, following these requisites, ReMB depth can be generalized using Eqn. 1.

$$ReMB_{depth} = \max(AD_{max}, \min(k)) \quad (1)$$

where  $AD_{max}$  is the maximum adder depth and  $k$  is the number of cascaded basic structures (i.e. layers).

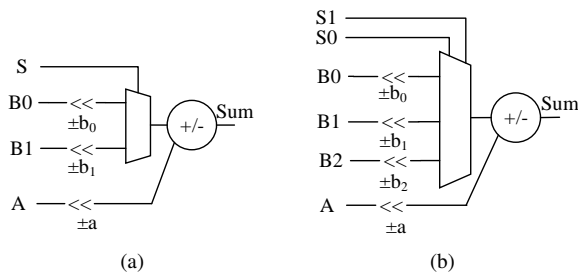

Fig. 2. Basic structure with (a) 2:1 multiplexer [11] and (b) 3:1 multiplexer.

TABLE I

SELECT LINE VALUES FOR MULTIPLEXERS (M0:M3) GIVEN IN FIG. 4.

Fixed-point	Integer	S0	S1	S2	S3
0.0107421875	11	1	0	1	0
0.033203125	34	1	0	1	1
0.03125	32	0	1	0	0
0.1875	192	0	0	2	0
0.0283203125	29	2	0	1	0
0.630859375	646	1	0	2	0
0.71484375	732	2	0	2	2
0.23046875	236	1	1	1	2

### A. Coefficient Quantization

Accuracy of DWT depends on precision of decomposition and reconstruction filter coefficients. Quantization of floating point coefficients results in quantization error which accumulates as it propagates through the filter bank. In order to evaluate finite-word length effects on an input data, filter coefficients associated with the *db4* mother wavelet are quantized with various precision and employed in DWT. ECG and ElectroEncephaloGram (EEG) signals obtained from Physionet [13] are selected as reference signals for evaluation. The error variance between input and reconstructed data, with floating point and fixed point filter coefficients are measured. Fig. 3 demonstrates measured error values using different coefficient word-lengths for both ECG (blue) and EEG (red). Approximately -70 dB error variance can be observed with coefficient word-length of 11 bits (10 fractional bits) which is decided to be negligible for this study as such error is not observable during time domain analysis by clinicians. The aforementioned coefficients are also scaled with  $2^{10}$  in order to have integer values and their absolute values are given in Table I.

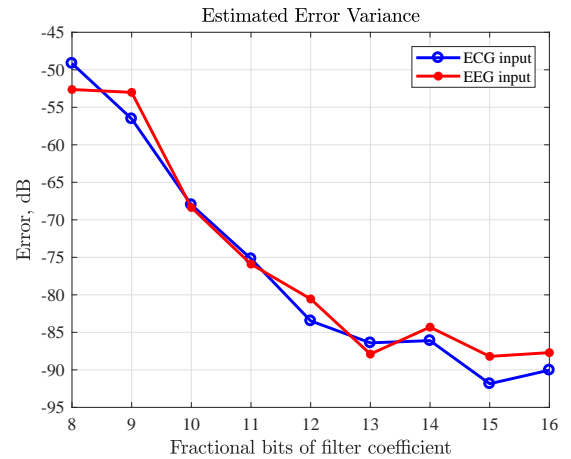

Fig. 3. Estimated error variance between input and reconstructed output with various filter coefficient precision.

## B. ReMb Design Details

The *db4* filters are implemented using ReMB designed by using the basic structures given in Fig 2 (b). There are eight distinct coefficients for both highpass and lowpass filters, which simplifies ReMB design procedure. Before starting the design, it is critical to evaluate adder depth of individual coefficients and the required number of layers needed to generate eight coefficients. One basic structure as in Fig. 2 (b) can generate three distinct values (i.e. its depth is three). Interconnecting two of these structures as a chain can generate maximum of nine distinct integers whereas three interconnected basic structures in a tree form with two layers can generate 27 integers at most. Therefore, the number of layers required for eight coefficients with the proposed basic structures is two. In addition, maximum adder depth of the coefficients is two, however three basic structures are required to realize all coefficients. Therefore, according to Eqn. 1,  $ReMB_{depth}$  is calculated as two with three basic structures interconnected in a tree form. Fig. 4 demonstrates the ReMB designed accordingly which employs three adders, one 2:1 and three 3:1 multiplexers. The main controller addresses the required select values to generate coefficients in correct order. Select values for each mux (M0:M3) in Fig. 4 are denoted as S0:S3, respectively and are presented in Table I where '0' selects top, '1' selects bottom (for 2:1 mux) or middle (for 3:1 mux) and finally '2' selects bottom input of a 3:1 mux. The proposed ReMB is targeted for FPGA platforms which takes the advantage of using the dedicated fast carry logic and implements multiplexers with no additional cost, as described before. However, when non-FPGA technologies are targeted, then ReMB can be redesigned with increased flexibility of using larger muxes. In FPGA platforms, resource cost for an individual mux with more than three inputs is comparable to an adder's. For instance, implementation of both 4-bit 4:1 mux and 4-bit full adder, utilize four LUTs each, whereas for non-FPGA technologies, multiplexer cost is relatively cheaper [14].

## III. EXPERIMENTAL RESULTS AND COMPARISONS

For this study, two time-multiplexed Time-Delay Line (TDL) implementations are realized in order to compare the resource utilization of a conventional reference design with a

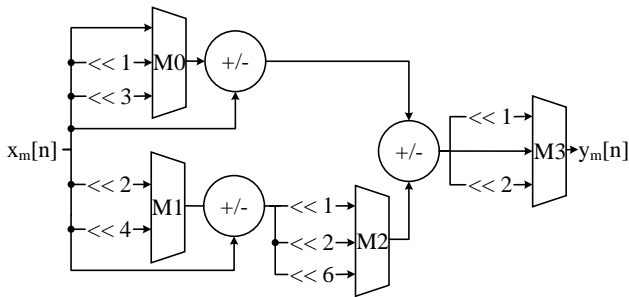

Fig. 4. Constant multiplier block designed for *db4* filter coefficients.

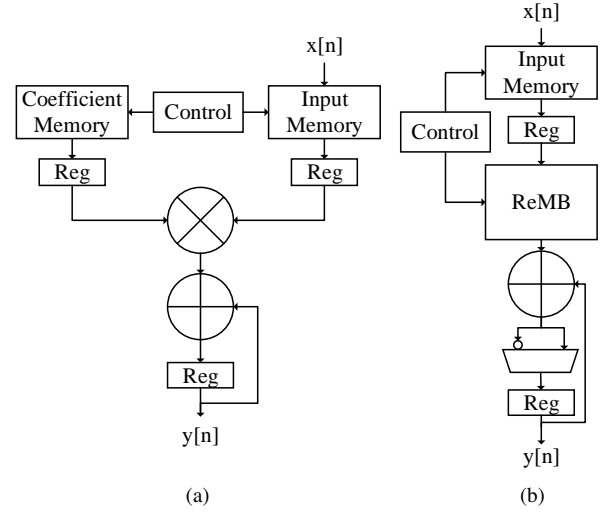

Fig. 5. A time-multiplexed TDL FIR filter implemented using (a) a dedicated multiplier and coefficient memory, and (b) the proposed ReMB block replacing multiplier and coefficient memory.

general purpose multiplier and a design with ReMB which are demonstrated in Fig. 5 (a) and (b), respectively. The reference time-multiplexed FIR filter structure is comprised of an input memory and a coefficient memory, and a single Multiply-ACcumulate (MAC) unit with a general purpose multiplier. Such filter structure operates sequentially. At every cycle, incoming data is multiplied with one coefficient stored in memory and this process is controlled with a simple control unit. Each generated product is accumulated with the previous one by using an accumulator and a register.

On the other hand, the proposed multiplier block generates absolute values of the required filter coefficients and thus, replaces coefficient memory and general purpose multiplier of the reference design. As it can be seen from Fig. 5 (b), a multiplexer is placed after the ReMB which is responsible for selecting between generated coefficient or its complement. Here, the controller is responsible for addressing the correct coefficient for each tap by generating correct control lines for multiplexers and adders/subtractors employed in the ReMB as well as the multiplexer after it (given in Section II).

For all experiments, filter architectures are designed using System Generator for DSP in MATLAB Simulink environment and are implemented on Kintex-7 FPGA with Vivado v16.2. The resource utilization for each aforementioned architecture after implementation is demonstrated in Table II in terms of LUTs, and Flip-Flops (FFs) and compared. In addition, the critical path delay for the multiplier and the ReMB are demonstrated in terms of adder and multiplier operation times, indicated using  $\tau_a$  and  $\tau_m$ , respectively. Looking at Table II, it can be observed that resource utilization for the proposed design is less compared to the reference design. The reference design's cost is estimated as 212 LUTs and 258 FFs where multiplier on its own costs 163 LUTs and 129 FFs. On the other hand, ReMB demonstrates high savings against the

TABLE II

RESOURCE UTILIZATION OF THE PROPOSED AND THE REFERENCE DESIGNS AFTER IMPLEMENTATION ON XILINX KINTEX-7 DEVICE.

	Filter resource utilization after implementation	
	Fig. 5 (a)	Fig. 5 (b)
LUT	212	144
FF	258	151
	Multiplier resource utilization	
	General purpose multiplier	ReMB
LUT	163	93
FF	129	56
Critical path delay	$\tau_m$	$2\tau_a$

reference design. Overall filter cost is reduced by 38% where ReMB utilizes 43% and 57% less LUTs and FFs, respectively. In FPGA implementations multiplexer delays are not included in path delay since they are embedded into LUTs, therefore it is only critical to consider the logic depth of the adders. The proposed design has a low logical depth since the adder depth is two, compared to the general multiplier which will reduce critical path delay for the multiplication operation.

#### IV. CONCLUSION

In this paper hardware efficient implementation for the *db4* wavelet and scaling filters are presented that employs a specifically designed ReMB. It is shown that the addition of multiplexers into shift-add networks provides reconfigurability to well known constant multiplication blocks. By taking the advantage of recent FPGA technologies having 6-input LUTs, 3:1 muxes are employed in the design of ReMBs at no additional hardware cost which updates the techniques proposed in the state of the art. In order to evaluate resource efficiency of the proposed structure, it is implemented on a Kintex-7 FPGA and is compared to reference designs. As the results reported in this paper demonstrate, the proposed ReMB can decrease overall hardware cost of a time multiplexed filter by 40% compared to a general purpose multiplier. The low-cost and hardware efficient structure of the proposed multiplier is suitable for DWT filter banks and can be used in low-cost embedded platforms for ambulatory physiological signal monitoring and analysis.

#### ACKNOWLEDGMENT

The authors wish to thank the University of Westminster Faculty of Science and Technology for the PhD Studentship.

#### REFERENCES

- [1] S. Mallat, *A wavelet tour of signal processing: the sparse way*. Academic Press, 2008.
- [2] S. Lahmiri, "Comparative study of ECG signal denoising by wavelet thresholding in empirical and variational mode decomposition domains," *Healthcare Technology Letters*, vol. 1, no. 3, pp. 104–109, 2014.
- [3] C. Ye, B. V. Kumar, and M. T. Coimbra, "Heartbeat classification using morphological and dynamic features of ECG signals," *IEEE Transactions on Biomedical Engineering*, vol. 59, no. 10, pp. 2930–2941, 2012.
- [4] N. K. Al-Qazzaz, S. Hamid Bin Mohd Ali, S. A. Ahmad, M. S. Islam, and J. Escudero, "Selection of mother wavelet functions for multi-channel EEG signal analysis during a working memory task," *Sensors*, vol. 15, no. 11, pp. 29 015–29 035, 2015.
- [5] Y. Eminaga, A. Coskun, S. A. Moschos, and I. Kale, "Low complexity all-pass based polyphase decimation filters for ecg monitoring," in *Ph. D. Research in Microelectronics and Electronics (PRIME), 2015 11th Conference on*. IEEE, 2015, pp. 322–325.
- [6] Y. Eminaga, A. Coskun, and I. Kale, "Two-path all-pass based half-band infinite impulse response decimation filters and the effects of their non-linear phase response on ecg signal acquisition," *Biomedical Signal Processing and Control*, vol. 31, pp. 529–538, 2017.
- [7] A. Darji, R. Arun, S. N. Merchant, and A. Chandorkar, "Multiplier-less pipeline architecture for lifting-based two-dimensional discrete wavelet transform," *IET Computers & Digital Techniques*, vol. 9, no. 2, pp. 113–123, 2014.
- [8] C.-H. Hsia, J.-H. Yang, and W. Wang, "An efficient VLSI architecture for discrete wavelet transform," in *Signal and Information Processing Association Annual Summit and Conference (APSIPA), 2015 Asia-Pacific*. IEEE, 2015, pp. 684–687.
- [9] J. Wu, A. Ang, K. M. Tsui, H. Wu, Y. S. Hung, Y. Hu, J. Mak, S.-C. Chan, and Z. Zhang, "Efficient implementation and design of a new single-channel electrooculography-based human-machine interface system," *IEEE Transactions on Circuits and Systems II: Express Briefs*, vol. 62, no. 2, pp. 179–183, 2015.
- [10] S. K. Madishetty, A. Madanayake, R. J. Cintra, V. S. Dimitrov, and D. H. Mugler, "VLSI architectures for the 4-tap and 6-tap 2-D Daubechies wavelet filters using algebraic integers," *IEEE Transactions on Circuits and Systems I: Regular Papers*, vol. 60, no. 6, pp. 1455–1468, 2013.
- [11] S. S. Demirsoy, I. Kale, and A. Dempster, "Reconfigurable Multiplier Blocks: Structures, Algorithm and Applications," *Circuits, Systems, and Signal Processing*, vol. 26, no. 6, pp. 793–827, 2007.
- [12] S. S. Demirsoy, I. Kale, and A. G. Dempster, "Synthesis of Reconfigurable Multiplier Blocks: Part I-Fundamentals," in *IEEE International Symposium on Circuits and Systems, ISCAS, 2005*. IEEE, 2005, pp. 536–539.
- [13] A. Goldberger, L. Amaral, L. Glass, J. Hausdorff, P. Ivanov, R. Mark, J. Mietus, G. Moody, C. Peng, and H. Stanley, "PhysioBank, PhysioToolkit, and PhysioNet: Components of a New Research Resource for Complex Physiologic Signals," *Circulation*, vol. 101, no. 23, pp. E215–20, 2000.
- [14] P. Tummeltshammer, J. C. Hoe, and M. Puschel, "Time-multiplexed multiple-constant multiplication," *IEEE Transactions on Computer-Aided Design of Integrated Circuits and Systems*, vol. 26, no. 9, pp. 1551–1563, 2007.