

PDF hosted at the Radboud Repository of the Radboud University Nijmegen

The following full text is a publisher's version.

For additional information about this publication click this link.

<http://hdl.handle.net/2066/20876>

Please be advised that this information was generated on 2017-12-05 and may be subject to change.

Plasmodium falciparum: A Comparison of the Activity of Pfs230-Specific Antibodies in an Assay of Transmission-Blocking Immunity and Specific Competition ELISAs

W. ROEFFEN, P. J. A. BECKERS, K. TELEN, T. LENSEN, R. W. SAUERWEIN, J. H. E. TH. MEUWISSEN, AND W. ELING

University of Nijmegen, Department of Medical Microbiology, P.O. Box 9101, 6500 HB Nijmegen, The Netherlands

ROEFFEN, W., BECKERS, P. J. A., TELEN, K., LENSEN, T., SAUERWEIN, R. W., MEUWISSEN, J. H. E. TH., AND ELING, W. 1995. *Plasmodium falciparum*: A comparison of the activity of Pfs230-specific antibodies in an assay of transmission-blocking immunity and specific competition ELISAs. *Experimental Parasitology* 80, 15–26. The activity of monoclonal antibodies (mAbs) that specifically recognize the *Plasmodium falciparum* sexual stage-specific protein Pfs230 was analyzed. All mAbs reacted with the surface of extracellular sexual forms of the parasite in a suspension immunofluorescence antibody reaction and precipitated the Pfs230 protein from an NP-40 extract of surface radioiodinated macrogametes/zygotes. Only mAb that bound complement blocked transmission, whereas mAb that did not bind complement but competed with the complement-binding mAb for binding to the same epitope did not block transmission. These mAbs were used to develop Pfs230-specific competition ELISAs to analyze epitope diversity and to analyze the binding characteristics of anti-Pfs230 antibodies in human serum. Transmission-blocking (TB) antibodies in test/field sera competed in the competition ELISA for binding with epitope-specific, labeled mAbs against Pfs230. At least five different epitope regions could be defined with the competition ELISAs. All 46 sera from gametocyte carriers immunoprecipitated the Pfs230 molecule, while 19 of these sera blocked transmission in the bioassay. Five of the transmission-blocking and one of the nonblocking sera competed with monoclonal antibodies. A method comparison analysis was used to determine agreement between reactions in a competitive ELISA and the TB activity examined in the bioassay. The index of agreement κ between outcomes of the bioassay and ELISA was fair to poor ($\kappa = 0.25$) but since its range includes values below 0 the relation between the data obtained by the bioassay and the competition ELISA can be explained by chance alone. The serological data did not reveal a correlation between immunoprecipitation of Pfs230 and TB activity. © 1995 Academic Press, Inc.

INDEX DESCRIPTORS AND ABBREVIATIONS: *Plasmodium falciparum*; Malaria; Antibodies; Competition ELISA; Transmission-blocking (TB); *Plasmodium falciparum* surface protein (Pfs); Kilodalton (kDa); Fast Protein Liquid Chromatography (FPLC); Sodium dodecyl sulfate–polyacrylamide gel electrophoresis (SDS–PAGE); Horseradish peroxidase (HRPO); Tissue culture medium-199 (M199) containing 0.1% glucose (M199-G); Room temperature (RT); Immunofluorescence microscopy with dried parasites as the antigen (IFA); Suspension IFA with live parasites as the antigen (SIFA); Fetal calf serum (FCS); Triton X-114 (TX-114); Phenylmethylsulfonyl fluoride (PMSF); Aqueous phase (AP); Detergent phase (DP); Monoclonal antibody (mAb); Immunoglobulin (Ig); Fluorescein isothiocyanate (FITC); HRPO-labeled rabbit α -mouse Ig (RAMPO); Optical density (OD); Immunoprecipitation (IP); Phosphate-buffered saline (PBS); Poly-L-lysine (PLL); Nonidet-P40 (NP-40); Pfs230 competition ELISA (C230-ELISA); Polyvinyl difluoride (PVDF).

INTRODUCTION

Malaria is transmitted from man to mosquito through gametocytes that develop in the blood of infected patients and are taken

up by the female mosquito when taking a bloodmeal. Gametocytes of *Plasmodium falciparum* synthesize molecules of apparent M_r on SDS–PAGE of 230 and 48/45 kDa (Pfs230 and Pfs48/45), which remain ex-

posed on the surface of macrogametes and zygotes (Vermeulen *et al.* 1985a, 1986; Kumar and Carter 1984). These molecules and a surface molecule of apparent M_r of 25 kDa (Pfs25) presented on developing zygotes, retort cells, and ookinetes are the targets of mAbs some of which can block the subsequent differentiation of the sexual stages in the mosquito; this is defined as transmission-blocking (TB) immunity (Rener *et al.* 1983; Vermeulen *et al.* 1985a; Quakyi *et al.* 1987). TB antibodies are found in sera from people exposed to natural malaria and are—at least in part—associated with immunoglobulin reactivity of these sera (Meuwissen *et al.* 1985; Mulder *et al.* 1993).

The conventional bioassay of TB activity is based on development of oocysts in mosquitoes after membrane feeding of gametocytes as described by Vermeulen *et al.* (1985a). It is a costly, labor-intensive assay, thus limiting the number of sera that can be tested. Development of a serological test predicting TB activity would greatly simplify the study of the significance of TB immunity. A number of studies indicate that antibody responses to epitopes of Pfs48/45 and Pfs230 are part of the response observed after several malaria episodes (Graves *et al.* 1988, 1990; Carter *et al.* 1989) and that some epitope regions are conserved in many isolates (Foo *et al.* 1991). Immunoprecipitation with sera from people living in endemic areas precipitated radioiodinated Pfs48/45 and Pfs230. In Papua New Guinea sera there was a good correlation between TB activity and antibody response to ^{125}I -labeled Pfs230, although no such correlation was found for Pfs48/45 antibody reactivity (Graves *et al.* 1988). Among the Sri Lanka sera no correlation was found between TB activity and the presence of antibodies to Pfs230 as detected by immunoprecipitation of radioiodinated gamete proteins (Premawansa *et al.* 1994).

In the present study a Pfs230-enriched

fraction from gametocytes was used for the production of anti-Pfs230 mAbs and development of ELISAs. Competition ELISAs using different HRPO-labeled mAbs, immunoprecipitation, and Western blot analysis were developed to characterize antibody reactivity to various epitopes of Pfs230 in sera collected from gametocyte carriers. Reactivity in the competition ELISA was compared to TB activity in the bioassay to analyze a possible predictive value of the competition ELISA for TB activity.

MATERIALS AND METHODS

Parasites

Mature gametocytes of *P. falciparum* (isolate NF54) were produced in an automated large-scale culture system as described by Ponnudurai *et al.* (1982). Mature gametocytes were isolated at 37°C to prevent gametocyte activation as follows. Parasite culture was diluted 10-fold in M199 containing 0.1% glucose (M199-G). After centrifugation for 15 min at 2000g the pelleted parasites were resuspended in M199-G, loaded on a cushion of 18% Nycodenz, and centrifuged for 30 min at 5000g as described by Vermeulen *et al.* (1985a). The purified gametocytes were used (a) directly, for SIFA, (b) allowed to exflagellate to collect macrogametes and zygotes for use as dried antigen in IFA, or (c) stored at -70°C until used for extraction of Pfs230.

Macrogametes and zygotes were purified and used for surface radioiodination and immunoprecipitation as described by Vermeulen *et al.* (1985a).

The Pfs230-Enriched Aqueous Phase (AP) Extract of Gametocytes

Gametocytes suspended in 140 mM NH_4Cl in 10 mM Tris/HCl (pH 7.4) were incubated on ice for 5 min to lyse the erythrocyte membrane and parasites were pelleted by centrifugation (5 min, 16,000g at RT). Parasites were solubilized in 2% TX-114 in a 10 mM Tris/HCl buffer (pH 7.4) containing 1 mM PMSF at 4°C as described by Bordier (1981) and Kumar (1985). The AP and detergent phase (DP) obtained by this method were collected separately. The AP (Pfs230-enriched antigen) was dialyzed against 0.1 M NH_4HCO_3 and freeze-dried in aliquots equivalent to 2×10^7 gametocytes.

Sera

Field sera. A total of 46 sera was collected from gametocyte carriers (aged between 6 and 36 years)

recruited at a dispensary in Yaounde, Cameroon (Tchuinkam *et al.* 1993).

Positive control. Serum of a Dutch expatriate who worked in an endemic malaria area in Tanzania for more than 30 years (St1). This serum was positive in all tests used.

Negative control. A panel of individual serum samples and a pooled sample of these sera (N56) were obtained from Dutch bloodbank donor volunteers, with no previous history of malaria.

Complement. Freshly obtained AB blood from Dutch bloodbank donors with no previous malaria exposure was allowed to clot at room temperature for 1 h and aliquots of the pooled serum were stored at -70°C until required. Freshly thawed samples were used as a source of complement.

Rabbit α -PLL serum. Rabbit anti-poly-L-lysine serum was a gift from Dr. P. Rotmans, Laboratory of Parasitology, University of Leiden, The Netherlands.

Monoclonal Antibodies

The Pfs230-specific mAb 28F1 has been described by Vermeulen *et al.* (1985a, 1986). MAb 18F25 was produced and characterized as described by Vermeulen *et al.* (1985a). MAbs 11E3, 12F10, 4H2, 12B3, and 14G8, all reacting with Pfs230, were a kind gift of Dr. R. Carter, Division of Biological Sciences, Edinburgh, England.

For the preparation of new mAbs freshly isolated aqueous phase from a TX-114 extraction (AP), equivalent to 2×10^7 parasites in 50 μl PBS, was emulsified in 50 μl Freund's complete adjuvant and injected intraperitoneally in BALB/c mice. The mice were boosted twice with AP in Freund's incomplete adjuvant. Serum samples were tested by ELISA (see below) and on Western blots with gametocyte proteins. Mice were killed 3 days after the last boost, spleen cells were fused with myeloma cells (P3/X63-Ag8.653), and suitable hybridomas were selected as described in more detail by Vermeulen *et al.* (1985a). The supernates were screened by antibody reactivity in (a) an IFA using air-dried sexual stage parasites, (b) SIFA and (c) a one-site ELISA using AP as antigen (see below). Positive wells were cloned twice by limiting dilution and further tested on Western blots and by immunoprecipitation (see below). Selected clones were further expanded and ascitic fluids were produced. TB activity of ascitic fluid or its purified IgG preparations was determined in the bioassay (see below).

Purification of Monoclonal Antibodies

Ascitic fluid was defatted with silicon dioxide (Sigma S-5631) as described by Neoh *et al.* (1986), the immunoglobulin (Ig)-containing supernate was dia-

lyzed against 0.1 M NH_4HCO_3 and freeze-dried in bottles or IgG was further purified using a semi-automated FPLC system (Pharmacia) equipped with a Protein A column (Pharmacia). The IgG preparation was mixed with buffer A (0.1 M Tris/HCl + 1.0 M Na_2SO_4 , pH 8.0) loaded on the column at a flow rate of 1 ml/min and washed with buffer A for 8 min. Subsequently, buffer B (0.1 M glycine/HCl, pH 2.5) was added to obtain a gradient of 5 to 50% B in 15 min followed by elution with 100% B for 5 min. The IgG-containing fractions were pooled, dialyzed against 0.1 M NH_4HCO_3 , and aliquots stored freeze-dried in bottles. All IgG subclasses including IgG1 can be recovered under these conditions.

Surface Immunofluorescence Assay

SIFA was performed with live macrogametes and zygotes. All incubations were done at 50 μl FCS for 15 min (for activation and exflagellation). A 50- μl antibody test sample was added and incubated for 15 min. After washing with PBS, the cells were incubated with 50 μl FITC-conjugated goat anti-mouse IgG (Cappel 55493) diluted in PBS with 0.05% Evans blue for 10 min. After two PBS washings, the cells were examined under a cover glass with vaseline-coated edges on a Leitz Ortholux fluorescence microscope (500 \times magnification).

Transmission-Blocking Assay

A bioassay, using membrane feeders to feed *A. gambiae* mosquitoes, was used to determine TB capacity of serum samples (Vermeulen *et al.* 1985a; Ponudurai *et al.* 1987, 1989). All samples were separately tested in the presence of active or inactivated complement; all measurements were repeated at least once. Field sera were diluted 3-fold and mAbs or IgG preparation of the sera 10-fold with negative human serum. Twenty mosquitoes per feeder were dissected 7 days after feeding, the number of oocysts on the stomach wall was counted and William's mean (adjusted geometric mean (GM)) oocyst number calculated (William, 1937). An experiment was considered successful if at least 90% of the mosquitoes of the controls carried oocysts. The adjusted GM was used to determine the reduction activity (*R*) according to the equation

$$R = \frac{T_c - T_i}{T_c} \times 100\%,$$

where T_i is the geometric mean for the test feeder and T_c is the geometric mean of three controls.

Because of assay variation only values over 85%

were considered to be a positive transmission-blocking result.

Immunoprecipitation

Macrogametes and zygotes were surface radioiodinated by catalyzed iodination (isotope 125 iodine), solubilized by NP-40, and the extract was used for indirect immunoprecipitation as described by Vermeulen *et al.* (1985a).

Labeling of the mAbs with HRPO

Labeling of FPLC-purified mAb with HRPO was performed using the periodate method with an input molar HRPO/IgG ratio of 4 according to Wilson and Nakane (1978). The labels were dialyzed against PBS, supplemented with thimerosal (0.01%) and FCS (1%), and the samples freeze-dried in bottles and stored at 4°C.

Enzyme-Linked Immunosorbent Assays

I. Detection of Pfs230. (a) Microtiter plates were coated with PLL, washed with PBS, and incubated with serial dilutions of AP in PBS. Subsequently, free PLL binding sites were blocked by incubation with 0.2 mg/ml rabbit α -poly-L-lysine Ig in PBS for 30 min. Following three washes with PBS, the wells were incubated with 50 μ l HRPO-labeled anti-Pfs230 mAb (2 μ g/ml) for 2 hr. After a washing step, plates were incubated with 60 μ l TMB (0.25 mM 3,3',5,5'-tetramethylbenzidine, 0.7 mM H₂O₂, 0.1 M sodium acetate, pH 5.5) substrate solution for 20 min. The enzyme reaction was stopped by adding 60 μ l 4 N H₂SO₄ and the optical density (OD) was determined on an ELISA reader at 450 nm (Titertek Multiskan MCC/340).

(b) Two-site ELISAs were carried out as described by Vermeulen *et al.* (1985b), Zavala *et al.* (1983), and Carter *et al.* (1985). Microtiter plates were coated with 50 μ l of anti-Pfs230 mAb (10 μ g/ml) in PBS for 30 min. Plates were washed three times with PBS and saturated with 5% FCS in PBS. After incubation with AP extract the wells were incubated with HRPO-labeled anti-Pfs230 mAbs, substrate and the absorbance read at 450 nm as above.

II. Competition ELISAs. Pfs230 was captured from AP extract in microtiter plates as described above under Ia or Ib. After three washes with PBS, wells were incubated with a mixture of 30 μ l test sample and 30 μ l HRPO-labeled anti-Pfs230 mAb for 2 hr. Competition ELISAs were carried out using serial twofold dilutions of unlabeled anti-Pfs230 mAbs (ranging from 31 to 4000 ng/ml) or human sera (ranging from 1/10 to 1/640) made up in PBS containing 0.1% FCS. The plates were washed, incubated with substrate, and the absorbance was read at 450 nm as above.

All incubations were carried out at room temperature. The competition titer is defined as the dilution of the test serum that results in the same OD reading as the (competition negative) control serum. Sera with titer > 1/20 are considered positive.

Comparison of the TB Assay and Competition ELISA for Sera

The results of competition ELISAs and the bioassay were compared by a statistical test on agreement using kappa as the index of observed agreement (Landis and Koch 1977; Altman 1991). The index kappa (κ) was calculated from the observed and expected (chance distribution) frequencies on the diagonal of the 2 x 2 table of outcomes of the bioassay and ELISA (see Table IV). The approximate standard error of κ is

$$SE(\kappa) = \sqrt{\frac{P_o(1 - P_o)}{n(1 - P_o)^2}}$$

where P_o is observed proportional agreement and P_e the expected proportional agreement by chance. The approximate 95% confidence interval is given by $\kappa \pm 1.96 SE(\kappa)$. The index of agreement κ has a maximum of 1.00 when agreement is perfect, a value of zero indicates no agreement better than chance. Negative values indicate disagreement. The guideline by Altman (1991) was used to determine the strength of agreement.

RESULTS

Detection and preservation of Pfs230 in gametocyte extracts. Pfs230 was found to be exclusively present in the AP of the TX-114 extract which also contained trace amounts of other protein molecules such as 27, 16, 48/45 kDa as detected by specific ELISAs and SDS-PAGE analysis (data not shown).

Immunoreactivity of Pfs230 in the freshly prepared AP with mAbs 18F25 and 28F1 as determined by one- or two-site ELISA or on Western blot decreased rapidly during further processing and storage. After two cycles of freeze-thawing of a freshly prepared AP, only 20% immunoreactivity was left with mAb 18F25 and no immunoreactivity at all with mAb 28F1. Pfs230 detection did not change using protein staining on SDS-PAGE gels (data not shown). In addition, immunoreactivity of Pfs230 was

lost during freeze-drying in PBS (increased salt concentrations generated during freeze-drying). Exposure to 10× concentrated PBS or 1 M NH₄HCO₃ solution led to an instantaneous loss of immunoreactivity in the one-site ELISA. Immune reactivity was preserved when AP was dialyzed against 0.1 M NH₄HCO₃, freeze-dried, and stored at 4°C. Pfs230 immunoreactivity appeared to be stable for 6 to 8 weeks when stored *in vacuo* or under N₂ gas and only 2 weeks when stored under air or in solution.

Immunoreactivity of anti-Pfs230 mAbs and epitope mapping. All mAbs including the newly developed 63F2A2 (IgG2a), 63F3C8, and 63F6D7 (both IgG1) as well as 18F25, 28F1, 4H2, 12B3, and 14G8 (all IgG1) and 11E3 and 12F10 (both IgG2a) reacted specifically with air-dried gametocytes and the surface of freshly prepared live intact macrogametes and zygotes. All above mentioned mAbs precipitated Pfs230 of ¹²⁵I surface radioiodinated gametes (data not shown). On Western blots of NP-40 extracts of nonlabeled gametocytes, mAbs 63F2A2, 63F6D7, 12F10, 18F25, and 11E3 recognized proteins of apparent M_r 230 and 260 kDa under nonreducing conditions. The other mAbs (63F3C8, 14G8, 4H2, 12B3,

and 28F1) showed no reactivity on Western blot (see Table I).

Checkerboard titrations with various concentrations of labeled mAbs and AP were performed to establish optimal conditions for Pfs230 detection. Such concentrations of antigen and HRPO-labeled mAb were chosen so that maximal reduction of the OD was obtained when small amounts of competing antibody were included in the test. Optimal conditions for the competition ELISA were considered to be present with >60% of maximal binding of HRPO-mAb and an OD reading of >1.0. For mAbs 63F2A2 (0.3 µg/ml) and 63F6D7 (0.5 µg/ml) equal concentrations of labeled mAb and the corresponding nonlabeled mAb at the 50% competition value was found. The HRPO-labeling method did not decrease the affinity of most mAbs. Only with mAbs 28F1 (1.0 versus 0.1 µg/ml) and 63F3C8 (2.5 versus 0.25 µg/ml) was considerably less of the nonlabeled, corresponding mAb needed for 50% competition, suggesting that the immunoreactivity of these mAbs was substantially reduced after labeling.

The epitope specificity of each mAb was determined by (a) using different capture and labeled mAbs in two-site ELISAs and

TABLE I
Epitope Recognition of Anti-Pfs230 mAbs in the Two-Site ELISA

	Pfs230 capture antibody	Blot	IgG	HRPO-labeled second mAb						
				18F25	11E3	63F6D7	63F2A2	12F10	63F3C8	28F1
1 ^a	18F25	+	1	-	-	+	+	+	+	+
	11E3	+	2a	-	-	+	+	+	+	+
2	63F6D7	+	1	+	+	-	-	-	+	+
	63F2A2	+	2a	+	+	-	-	-	+	+
	12F10	+	2a	-	-	-	-	-	-	-
3	63F3C8	-	1	+	+	+	+	+	-	+
	4H2	-	1	+	nd	+	+	+	-	+
	12B3	-	1	+	nd	+	+	+	-	+
4	28F1	-		+	+	+	+	-	+	-
5	14G8	-	1	+	+	+	+	+	+	+

Note. (+) Positive reaction; (-) no reaction; nd, not done; blot, immunoreaction on a Western blot; IgG, immunoglobulin subclass.

^a Epitope region.

(b) competition between labeled mAbs and various unlabeled mAbs in one-site competition ELISAs. None of the labeled mAbs bound to Pfs230 when captured by the corresponding nonlabeled mAbs. The results with both systems (Tables I and II) suggest the presence of five distinct epitopes or epitope regions with two exceptions; (a) when 12F10 was used to capture Pfs230 no reaction with any of the labeled mAbs could be found, whereas 12F10 reacted with Pfs230 captured by several other mAbs. This may indicate that coated mAb 12F10 cannot capture Pfs230. (b) Competition between mAbs was independent of the use of the mAb in labeled or unlabeled form, except for 63F2A2. In the one-site ELISA, 63F2A2 competed with labeled 28F1, but labeled 63F2A2 did not compete with unlabeled 28F1. This may indicate that 63F2A2 and 28F1 react with the same epitope but with a considerable difference in affinity. A tentative map of the five epitope regions is given in Fig. 1.

Transmission-blocking activity of mAbs. Ascitic fluid and/or purified IgG from the hybridomas were included in the transmission-blocking feeder assay in the presence of either active or inactivated complement. Figure 1 shows that 5 μ g of mAbs 11E3,

12F10, and 63F2A2 (all IgG2a) blocked transmission more than 99%, but only in the presence of complement. MAbs 18F25, 63F6D7, 63F3C8, 4H2, 12B3, 28F1, and 14G8 (all being IgG1) did not reduce transmission irrespective of the presence of complement. Thus, epitope analysis and transmission-blocking experiments show that both blocking and nonblocking mAbs reacted with the same epitope and also compete for binding to that epitope. Transmission-blocking activity correlates with the presence of the complement fixing IgG2a isotypes which are only available for two epitopes (see Fig. 1).

Transmission-blocking activity in human field sera. Forty-six sera from gametocyte carriers, heat inactivated at 56°C for 30 min, were tested in feeding experiments in the presence of active and inactivated complement. Nineteen (41.3%) of these 46 sera consistently blocked transmission in the presence of complement. Twelve of the 19 sera with a TB activity were retested in the bioassay both in the presence of either active or inactivated complement. None of these 12 field sera showed a complement-dependent transmission-blocking activity (data not shown).

Pfs230-associated TB activity. All 46

TABLE II
Competition of mAbs in the One-Site Pfs230 ELISA

Competition	mAb	HRPO-labeled mAb						
		18F25	11E3	63F6D7	63F2A2	12F10	63F3C8	28F1
1 ^a	18F25	+	+	-	-	-	-	-
	11E3	+	+	-	-	-	-	-
2	63F6D7	-	-	+	+	+	-	-
	63F2A2	-	-	+	+	+	-	+
	12F10	-	-	+	+	+	-	-
3	63F3C8	-	-	-	-	-	+	-
	4H2	-	-	-	-	-	+	-
	12B3	-	-	-	-	-	+	-
4	28F1	-	-	-	-	-	-	+
5	14G8	-	-	-	-	-	-	-

Note. (+) Competition between labeled and nonlabeled mAbs; (-) no competition between labeled and nonlabeled mAbs.

^a Epitope region.

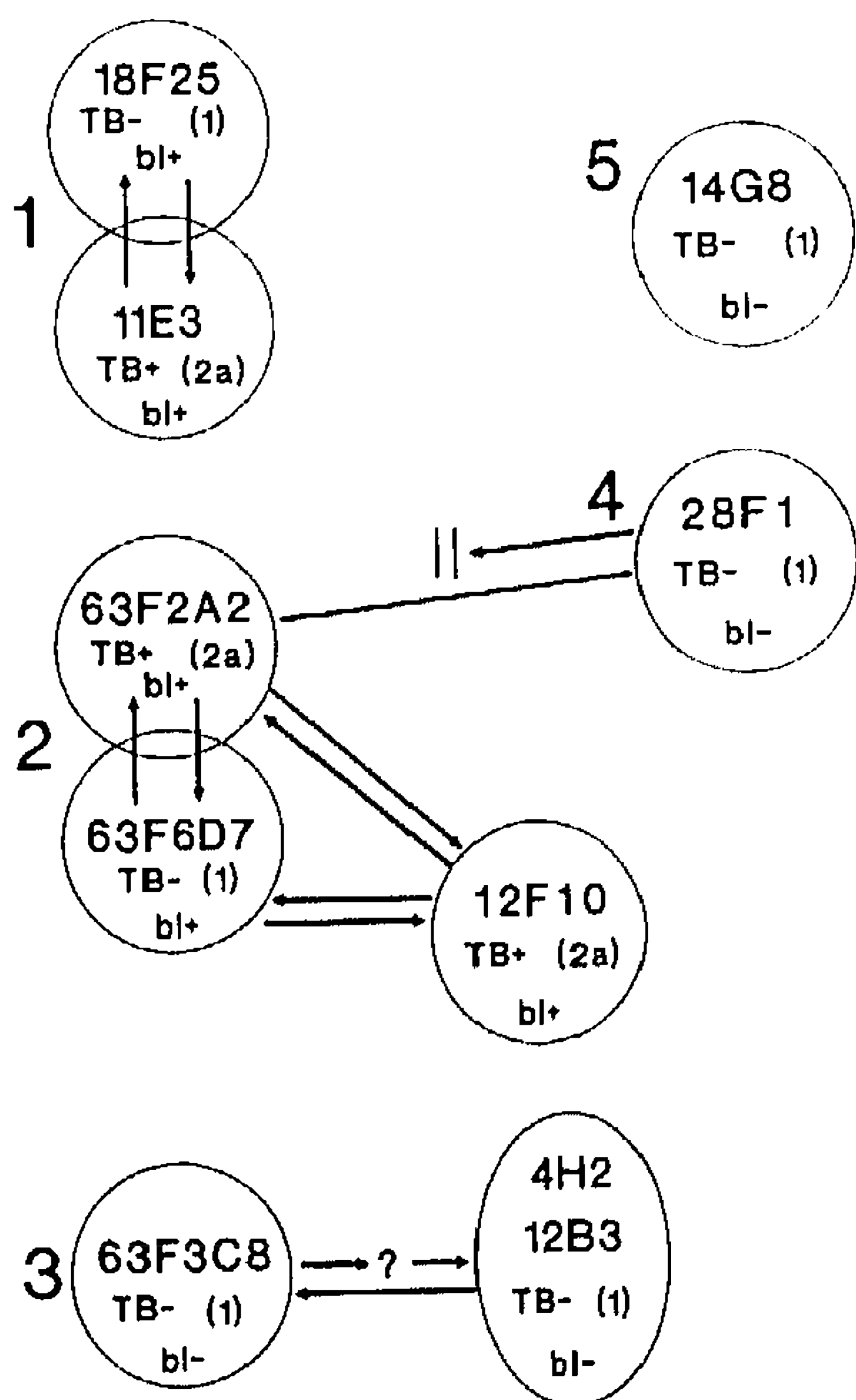

FIG. 1. Epitope regions of Pfs230 identified with a series of monoclonal antibodies tested in a one-site competition ELISA. MABs are either effective at blocking transmission of infection to mosquitoes (TB+) or ineffective (TB-). Competitive interactions in the ELISA are indicated as (→), no competition (→||) or not tested (→?). The isotype of the mAb is given in parenthesis. Reaction with Pfs230 on Western blot is given as positive (bl+) and negative (bl-).

sera of gametocyte carriers precipitated a molecule of apparent M_r on SDS-PAGE of 230 kDa from NP-40 extracts of ^{125}I surface radioiodinated gametes and reacted with molecules of apparent M_r of 230 and 260 kDa on a Western blot of NP-40 extracts of nonlabeled gametocytes under nonreducing conditions (data not shown). These results also showed that the antibodies present in the sera of the gametocyte carriers to ^{125}I -labeled Pfs230 precipitated a variable amount of the Pfs230 band. Due to variation of the ^{125}I labeling of various batches of parasites used for these analysis our technique only permitted a semiquantitative analysis and no correlation was found between antibody reactivity to ^{125}I -labeled Pfs230 and TB activity.

These 46 sera were further analyzed in a two-site competition ELISA with 18F25 as capture mAb and HRPO-63F2A2 as label. Figure 2 shows competition by a serial diluted positive (St1) in comparison to a negative serum (N56). The negative serum did not compete with HRPO-63F2A2 for binding to Pfs230. The overall interassay variable in this test (six times tested in duplicate) has an average deviation of the mean OD at each dilution step of 0.12 (21%). The overall intraassay variation resulted in an average deviation of the mean. Seven different mAbs reactive to the five epitopes/regions of Pfs230 described above, including the complement-dependent TB mAbs 11E3 and 63F2A2, were labeled with HRPO to investigate their competition with antibodies in serum samples of gametocyte carriers in the two-site competition ELISA. Table III shows that competition-positive human field sera (6 of 46) competed with all labeled mAbs, i.e., with all epitopes/regions available, with no exception either in the competition-positive or negative sera. No significant differentiation in antibody responses to the different Pfs230 epitopes was found. Five of these six sera blocked transmission. Serum 41 (see Table III), the only nonblocking serum, reduced transmission in a complement-dependent way.

The correlation between the TB activity (positive $\geq 85\%$, negative $< 85\%$) and the Pfs230 competition ELISA is depicted in Table IV. Five (26%) serum samples were positive in the TB assay and in the competition ELISA, 14 (30%) were negative in the competition ELISA but positive in the TB assay, and 26 (56%) were negative in both tests. The index of agreement between the outcomes of bioassay and the competition ELISA is $\kappa = 0.25$, 95% confidence interval $-0.06, +0.56$. The index indicates (Altman, 1991) that agreement is fair to poor and the negative value in the confidence interval indicates that agreement can be explained by chance. The ELISA outcomes

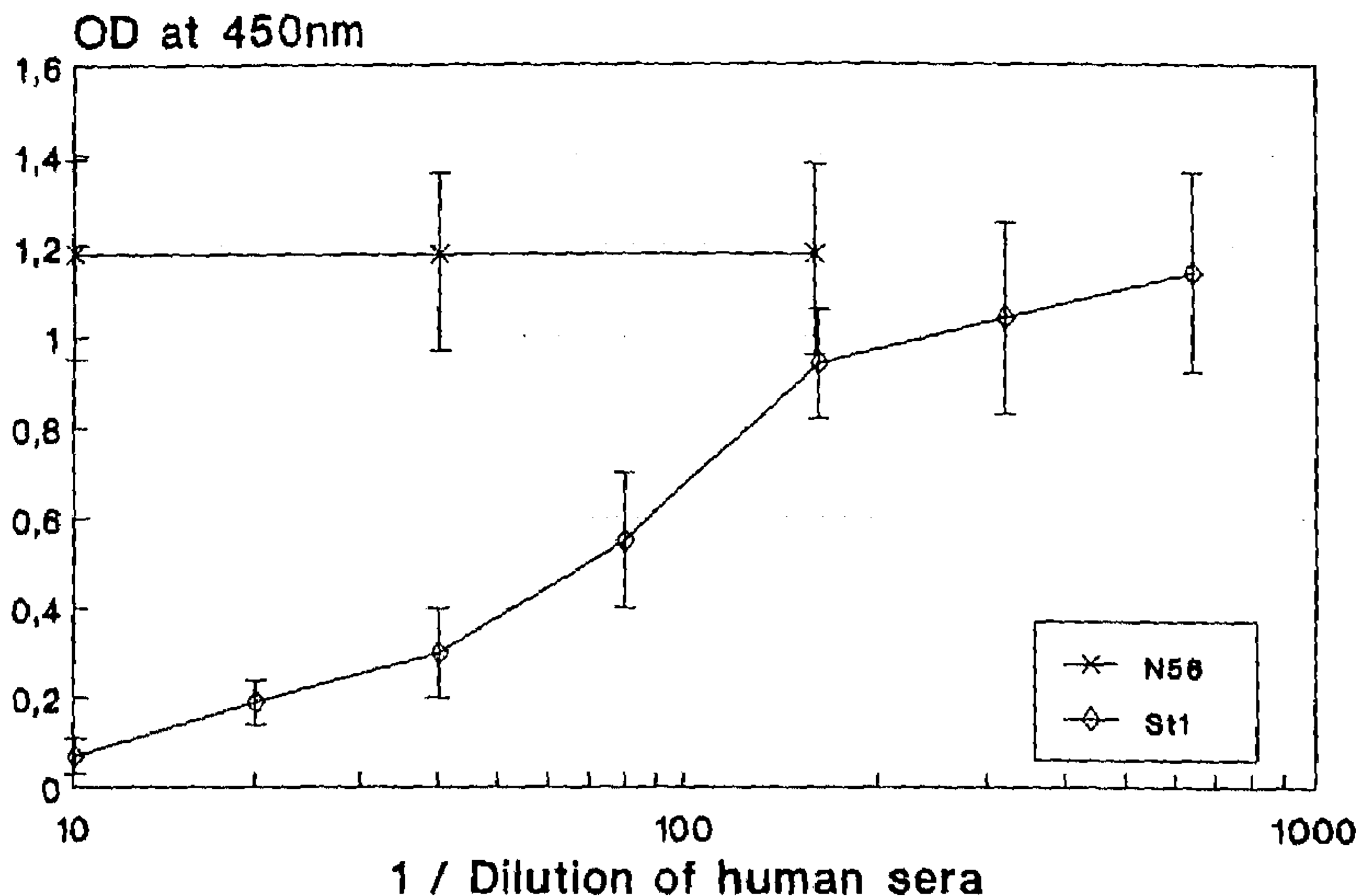

FIG. 2. Optical densities at 450 nm with increasing serum dilutions in a two-site competition ELISA. MA b 18F25 was used to capture the Pfs230 molecule from the aqueous phase and HRPO-63F2A2 for competition with a positive (St1) and negative (N56) human serum.

show a relative specificity of 96% (26 of 27) and a relative sensitivity of 26% (5 of 19).

DISCUSSION

A panel of monoclonal antibodies belonging to different IgG subclasses was analyzed for Pfs230 binding and TB activity. All mAbs reacted in the indirect IFA with

the surface of macrogametes and zygotes of *P. falciparum* and all immunoprecipitated Pfs230 from NP-40 extracts of surface radioiodinated macrogametes and zygotes. On Western blots prepared from gametocyte extracts, only mAbs 18F25, 11E3, 63F2A2, 63F6D7, and 12F10 recognize Pfs230 under nonreducing conditions. In

TABLE III

Percentage Transmission-Reducing Activity (R) in the Presence of Active (AC) or Inactivated (IC) Complement and the Epitope-Specific Competition Titer of Five Pfs230 Epitope Regions in Positive Field Sera from 46 *P. falciparum* Gametocyte Carriers

Serum	R		HRPO-labeled competing mAb						
	AC	IC	18F25	11E3	63F2A2	63F6D7	63F3C8	28F1	14G8
			(1)	(1)	(2)	(2)	(3)	(4)	(5)
4	99	nd ^a	160	320	80	160	80	160	640
19	100	98	80	40	40	80	40	80	320
38	90	nd	80	40	40	160	80	80	nd
39	96	97	80	80	40	160	40	80	320
41	73	18	40	80	40	80	40	40	160
48	89	80	80	80	40	160	40	40	160
N56 ^b	0	0	—	—	—	—	—	—	—
St1 ^c	100	100	320	160	160	640	80	160	nd

(—) Titer < 1/40; () epitope region;

^a nd, not done.

^b N56, A pool from Dutch blood donors with no history of malaria.

^c St1, A positive control serum which blocks transmission.

TABLE IV
Agreement between Transmission-Blocking Activity (TB Assay) and Pfs230 Competition ELISA (C230-ELISA) of 46 Sera from Gametocyte Carriers, Cameroon

TB assay	Number of C230-ELISA serum samples		Total
	Positive	Negative	
≥85%	5	14	19
<85%	1	26	27
Total	6	40	46

Note. Relative specificity = 26 of 27, or 96.3%; relative sensitivity = 5 of 19, or 26.3%; observed proportional agreement $(5 + 26)/46 = 0.67$; chance proportional agreement $(6/46 \times 19/46) + (40/46 \times 27/46) = 0.57$; observed minus chance agreement $(0.67 - 0.57) = 0.11$; maximum possible agreement beyond chance level $(1 - 0.57) = 0.43$; agreement quotient (κ), $0.11/0.43 = 0.25$.

addition, on SDS-PAGE a protein of apparent M_r of 260 kDa is also recognized on blots. This difference between results obtained with immunoprecipitation and Western blot analysis has been described before (Quakyi *et al.* 1987) and is best explained by the intracellular localization of a higher M_r precursor of Pfs230. MAbs can also be subdivided by their ability to block transmission, i.e., all IgG1 mAbs were negative and IgG2a mAbs (11E3, 63F2A2, and 12F10) blocked transmission in a complement-dependent reaction. Complement-dependent lysis of macrogametes and zygotes *in vitro* by Pfs230 mAbs has been described by Quakyi *et al.* (1987) and has also been found in the *P. gallinaceum* system (Kaushal *et al.* 1983).

These mAbs were used for the development of a number of different ELISAs in order to construct an epitope map of Pfs230 (Fig. 1), to determine the presence of anti-Pfs230 antibodies in field sera and to correlate presence of anti-Pfs230 antibodies in field sera with TB activity of these sera as observed in the bioassay.

The Pfs230 antigen used in these ELISAs

was prepared by Triton TX-114 (gametocyte extraction and phase separation as described by Bordier (1981) and Kumar (1985). It appeared that immunoreactivity of Pfs230 in these extracts was lost upon storage in PBS solution, after freeze-thawing, or exposure to high-salt concentration. The use of aqueous solutions containing a volatile buffer for freeze-drying and storage *in vacuo* prevented loss of immunoreactivity for periods of 2 months. Loss of immunoreactivity of Pfs230 after exposure to high-salt concentration has been observed before (Kumar and Wizel, 1992). The loss of immunoreactivity in solution suggests that oxidative changes could be involved in conformational changes of Pfs230. However, storage of AP in the presence of either vitamin E or glutathione did not prevent loss of immunoreactivity (data not shown).

One-site ELISAs could not be developed by direct coating of Pfs230 to the plates, but was realized by coating on a precoat of poly-L-lysine or Pfs230-specific mAb. The positive charge of poly-L-lysine most probably enables binding with the glutamate-rich Pfs230 (Williamson *et al.* 1993).

This panel of mAbs enabled the recognition of five different epitope regions on the Pfs230 molecule, each epitope being present only once. Monoclonal antibodies allocated to two epitope regions (here designated 1 and 2) were able to react on a Western blot. All mAbs of the complement fixing IgG2a subclass blocked transmission, whereas none of the mAbs of the complement nonfixing IgG1 subclass did. Thus, both TB-positive and negative antibodies can bind to the same epitope and compete with one another for binding to that epitope. MAbs to the three other regions (designated 3 to 5) did not block transmission but these were all of the IgG1 subclass.

In a panel of sera from gametocyte carriers from Cameroon all 46 sera immunoprecipitated Pfs230, and 19 sera exhibited TB

activity. Sera were classified with respect to their capacity to immunoprecipitate Pfs230 by a semiquantitative analysis of autoradiograms; compared to the results of the TB bioassay this revealed no correlation (P value = 0.396). None of 12 sera showing TB activity needed the presence of complement for this activity. More sera need to be tested before definite conclusions can be drawn on the role of complement in TB activity of human field sera.

Six sera of these gametocyte carriers from Cameroon were positive in the competition ELISA and this was independent of the epitope region analyzed, indicating that there was no epitope restriction. Five of these competition-positive sera also blocked transmission in the bioassay, but 14 of the 19 blockers were negative in the competition assays.

To compare the outcomes of TB assay and ELISA a statistical test for comparison of proportions or association is not considered appropriate. Besides sensitivity and specificity a measure of agreement is required rather than association. The index of agreement κ measures the amount of agreement beyond chance and can be used for the correlation analysis. In gametocyte carriers the amount of agreement was fair to poor but since the confidence interval contains zero, this implies that the agreement can be explained by chance.

In summary, the Cameroon field sera exhibit (a) absence of complement dependency of TB activity, (b) reactivity with all available epitopes of Pfs230 analyzed so far, and (c) no correlation between either the Pfs230 competition ELISA or immunoprecipitation of Pfs230 from NP-40 gametocyte extracts and TB activity as observed in the bioassay. This raises the question whether under field conditions TB activity is Pfs230 mediated.

Our results are in contrast to results obtained in a series of Papua New Guinea sera, where Graves *et al.* (1988) observed a correlation between immunoprecipitation

of Pfs230 and reduction of infectivity to mosquitoes. In our hands all the Cameroon sera precipitated Pfs230 and a semiquantitative analysis on autoradiograms revealed no correlation with TB activity. One aspect is the difference in study populations. A parallel study analyzing TB activity and antibody reactivity against Pfs230 as determined by immunoprecipitation in a Sri Lanka population failed to show this correlation (Premawansa *et al.* 1994). Our data do not exclude the possibility that Pfs230-mediated TB activity might be present in field sera which are complement independent. Another important question is to find out whether Pfs230-mediated TB activity is always complement dependent.

ACKNOWLEDGMENTS

We are grateful to Truus Derks and Marianne Sieben for production and purification of monoclonal antibodies, to Marga Bolmer, Arianne Huisman, and Geertjan van Gemert for parasite cultures and transmission experiments, and to Bert Mulder for supplying the serum samples. The generous gift of various mAbs by Dr. R. Carter is thankfully acknowledged. This study was supported by the EEC STD 004/2, 633.

REFERENCES

- ALTMAN, D. G. 1991. Practical statistics for Medical Research. Chapman & Hall, London.
- BORDIER, C. 1981. Phase separation of integral membrane proteins in Triton X-114 solution. *Journal of Biological Chemistry* 256, 1604–1607.
- CARTER, R., BUSHELL, G., SAUL, A., GRAVES, P. M., AND KIDSON, C. 1985. Two apparently nonrepeated epitopes on gametes of *Plasmodium falciparum* are targets of transmission blocking antibodies. *Infection and Immunity* 50, 102–106.
- CARTER, R., GRAVES, P. M., QUAKYI, I. A., AND GOOD, W. F. 1989. Restricted or absent immune responses in human populations to *Plasmodium falciparum* gamete antigens that are targets of malaria transmission-blocking antibodies. *Journal of Experimental Medicine* 169, 135–147.
- FOO, A., CARTER, R., LAMBROS, C., GRAVES, P., QUAKYI, I., TARGETT, G., PONNUDURAI, T., AND LEWIS, G. 1991. Conserved and variant epitopes of target antigens of transmission-blocking antibodies among isolates of *Plasmodium falciparum* from Malasia. *American Journal of the Tropical Medicine and Hygiene* 44, 623–631.
- GRAVES, P. M., CARTER, R., BURKOT, T. R.,

- QUAKYI, I. A., AND KUMAR, N. 1988. Antibodies to *Plasmodium falciparum* gamete surface antigens in Papua New Guinea sera. *Parasite Immunology* 10, 209-218.
- GRAVES, P. M., DOUBROVSKY, A., CARTER, N., AND BECKERS, P. 1990. High frequency of antibody response to *Plasmodium falciparum* gametocyte antigen during acute malaria infections in Papua New Guinea highlanders. *American Journal of Tropical Medicine and Hygiene* 44, 515-520.
- KAUSHAL, D. C., CARTER, R., RENER, J., GROTEN-DORST, C., MILLER, L. H., AND HOWARD, J. H. 1983. Monoclonal antibodies against surface determinants on gametes of *Plasmodium gallinaceum* block transmission of malaria parasites to mosquitoes. *Journal of Immunology* 131, 2557-2562.
- KUMAR, N. 1985. Phase separation in Triton X-114 of antigens of transmission blocking immunity in *Plasmodium gallinaceum*. *Molecular and Biochemical Parasitology* 17, 343-358.
- KUMAR, N., AND CARTER, R. 1984. Biosynthesis of the target antigens of antibodies blocking transmission of *Plasmodium falciparum*. *Molecular and Biochemical Parasitology* 13, 333-342.
- KUMAR, N., AND WIZEL, B. 1992. Further characterization of interactions between gamete surface antigens of *Plasmodium falciparum*. *Molecular and Biochemical Parasitology* 53, 113-120.
- LANDIS, J. R., AND KOCH, G. G. 1977. The measurement of observed agreement for categorical data. *Biometrics* 33, 159-174.
- MEUWISSEN, J. H. E. TH., PONNUDURAI, T., VERMEULEN, A. N., AND SMITS, M. 1985. Candidate antigens: Studies on the development of a *P. falciparum* malaria vaccine for the induction of transmission-blocking immunity. In *Proceedings of the Asia and Pacific Conference on Malaria*, (W. A. Siddiqui, Ed.), pp. 133-142. University of Hawaii, Hawaii.
- MULDER, B., TCHUINKAM, T., DECHERING, K., VERHAVE, J. P., CARNEVALE, P., MEUWISSEN, J. H. E. TH., AND ROBERT, V. 1993. Malaria transmission-blocking activity in experimental infections of *Anopheles gambiae* with naturally infected *Plasmodium falciparum* gametocyte carriers. *Transactions of the Royal Society of Tropical Medicine and Hygiene* 88, 121-125.
- NEOH, S. H., GORDON, C., POTTER, A., AND ZOLA, H. 1986. The purification of mouse monoclonal antibodies from ascitic fluid. *Journal of Immunological Methods* 91, 231-235.
- PONNUDURAI, T., LENSEN, A. H. W., LEEUWENBERG, A. D. E. M., AND MEUWISSEN, J. H. E. TH. 1982. Cultivation of fertile *Plasmodium falciparum* gametocytes in semi-automated systems. 1. Static cultures. *Transactions of the Royal Society of Tropical Medicine and Hygiene* 76, 812-818.
- PONNUDURAI, T., VAN GEMERT, G. J. A., BENSINK, T., LENSEN, A. H. W., AND MEUWISSEN, J. H. E. TH. 1987. Transmission blockade of *Plasmodium falciparum*: Its variability with gametocyte numbers and concentration of antibody. *Transactions of the Royal Society of Tropical Medicine and Hygiene* 81, 491-493.
- PONNUDURAI, T., LENSEN, A. H. W., VAN GEMERT, G. J. A., BENSINK, M. P. E., BOLMER, M., AND MEUWISSEN, J. H. E. TH. 1989. Infectivity of cultured *Plasmodium falciparum* gametocytes to mosquitoes. *Parasitology* 98, 165-173.
- PREMAWANSA, S., GAMAGE-MENDIS, A., PERERA, L., BEGARNIE, S., MENDIS, K., AND CARTER, R. 1994. *Plasmodium falciparum* transmission-blocking immunity under conditions of low endemicity as in Sri Lanka. *Parasite Immunology* 16, 35-42.
- QUAKYI, I. A., CARTER, R., RENER, J., KUMAR, N., GOOD, M. F., AND MILLER, L. H. 1987. The 230 kDa gamete surface protein of *Plasmodium falciparum* is also a target for transmission-blocking antibodies. *Journal of Immunology* 139, 4213-4217.
- RENER, J., GRAVES, P. M., CARTER, R., WILLIAMS, J. L., AND BURKOT, T. A. 1983. Target antigens of transmission-blocking immunity on gametes of *Plasmodium falciparum*. *Journal of Experimental Medicine* 158, 976-981.
- TCHUINKAM, T., MULDER, L., DECHERING, K., STOFFELS, H., VERHAVE, J. P., CARNEVALE, P., MEUWISSEN, J. H. E. TH., AND ROBERT, V. 1993. Experimental infections of *Anopheles gambiae* with *Plasmodium falciparum* in Cameroon: Infectivity of gametocytes of naturally infected gametocyte carriers in Cameroon: factors influencing the infectivity of mosquitoes. *Tropical Medicine and Parasitology* 44, 271-276.
- VERMEULEN, A. N., PONNUDURAI, T., BECKERS, P. J. A., VERHAVE, J. P., SMITS, M. A., AND MEUWISSEN, J. H. E. TH. 1985a. Sequential expression of antigens on sexual stages of *Plasmodium falciparum* accessible to transmission blocking antibodies in the mosquito. *Journal of Experimental Medicine* 162, 1460-1476.
- VERMEULEN, A. N., ROEFFEN, W. F. G., HENDERIK, J. B. J., PONNUDURAI, T., BECKERS, P. J. A., AND MEUWISSEN, J. H. E. TH. 1985b. *Plasmodium falciparum* transmission blocking antibodies recognize monovalently expressed epitopes. *Developments in Biological Standardization* 62, 91-97.
- VERMEULEN, A. N., VAN DEURSEN, J., BRAKENHOFF, R. H., LENSEN, T. H. W., PONNUDURAI, T., AND MEUWISSEN, J. H. E. TH. 1986. Characterisation of *Plasmodium falciparum* sexual stage antigens and their biosynthesis in synchronised gametocyte cultures. *Molecular and Biochemical Parasitology* 20, 155-163.
- WILLIAM, C. B. (1937). The use of logarithms in the

- interpretation of certain entomological problems. *Annals of Applied Biology* 24, 404-414.
- WILLIAMSON, K. C., CRISCIO, M. D., AND KASLOW, D. C. 1993. Cloning and expression of the gene for *Plasmodium falciparum* transmission-blocking target antigen, Pfs230. *Molecular and Biochemical Parasitology* 58, 355-358.
- WILSON, M. B., AND NAKANE, P. K. 1978. "Immunofluorescence and Related Staining Techniques." Elsevier, Amsterdam.
- ZAVALA, F., COCHRANE, A. H., NARDIN, E. H., NUSSENZWEIG, R. S., AND NUSSENZWEIG, V. 1983. Circumsporozoite proteins of malaria parasites contain a single immunodominant region with two or more identical epitopes. *Journal of Experimental Medicine* 157, 1947-1957.

Received 20 December 1993; accepted with revision 7 June 1994