

PRODUCTION GEOMETRICAL ANALYSIS OF LOGARITHM SPIRAL  
BACKWARD TURNED CURVE<sup>⊗</sup>LOGARITMIKUS SPIRÁLIS HÁTRAESZTERGÁLÁSI GÖRBE  
GYÁRTÁSGEOMETRIAI VIZSGÁLATABODZÁS, Sándor <sup>1</sup>, Dr. DUDÁS, Illés <sup>2</sup>

<sup>1</sup> PhD student, University of Miskolc, Department of Production Engineering, 3515 Miskolc, Egyetemváros  
<sup>1</sup>sandor.bodzas@uni-miskolc.hu

<sup>2</sup> DSc professor, University of Miskolc, Department of Production Engineering, 3515 Miskolc, Egyetemváros  
<sup>2</sup>illes.dudas@uni-miskolc.hu

**Abstract:** Only such tools could be used for high precision machining of shaping surfaces, the profiles of which do not change at resharpening. The backward turned hobs are appropriate for this purpose. In case of logarithm spiral backward turned curve the profile constancy can be provided in case of the repeated resharpening of hob.

**Keywords:** hob, logarithm spiral, backward turning

**Kivonat:** Alakos felületek nagy pontosságú megmunkálásához csak olyan szerszámok használhatók, amelyeknek a szelvénye újraélezéskor nem változik. Erre a célra a hátraesztergált fogú marók felelnek meg. Logaritmikus spirális hátraesztergálási görbe esetén biztosítható a maró többszöri újraélezése esetén is a profilállandóság.

**Kulcsszavak:** lefejtőmaró, logaritmikus spirális, hátraesztergálás

## 1. INTRODUCTION

The tiller surface of hob is such worm on which sliver slots are prepared. They backward turn and backward grind the hob cogs because of the resharpening assurance. The cog profile of the hob in normal plane is equal to the profile of the basic worm (Figure 1).



Figure 1. Worm gear hobs

<sup>⊗</sup> Reviewed paper. Submitted: 29. 09. 2010., Accepted: 22. 10. 2010.  
Szaklektorált cikk. Leadva: 2010. szeptember 29., Elfogadva: 2010. október 22.  
Reviewed by Dr. Gábor PÁY / Lektorálta: Dr. PÁY Gábor

During production the tooth space of the worm gear is equal to hob cog, so the kinematical track of the tool creates the worm gear cog profile. This is called direct motion mapping [2, 4].

The advantage of the solution: there is no from cog to cog division, so work is without interruption (Figure 2).



Figure 2. Worm gear production

## 2. GEOMETRICAL SHAPING OF THE TOOL

We define the limiter surface of one cog of the tool and the cutting edge on Figure 3. The most important limiter surfaces of the cog (Figure 3):

- H face surface;
- $R_B, R_J$  back surfaces (left and right);
- $F_h$  back surface of head ribbon;
- F head ribbon.

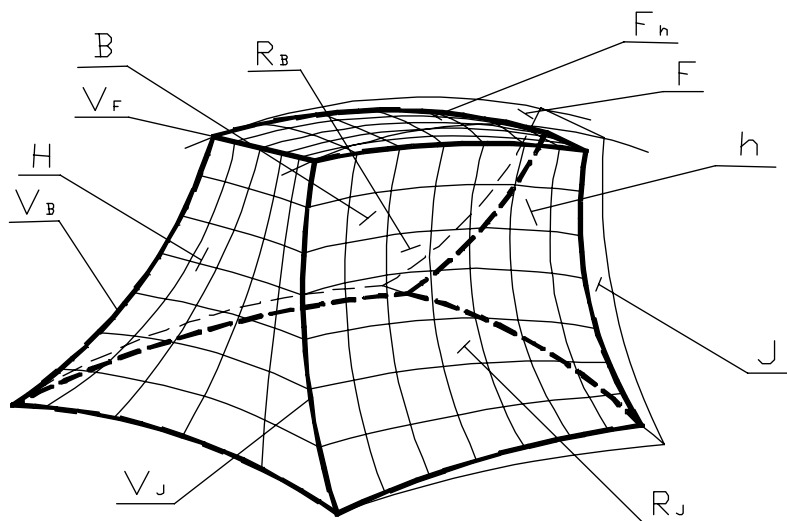

Figure 3. Surface elements and edges of hob

The most important cutting edges (Figure 3):

- $V_B$  left side edge as intersection of B tooth and H face surfaces;
- $V_J$  right side edge as intersection of J tooth and H face surfaces;
- $V_F$  addendum edge as intersection of F head ribbon and H face surfaces.

When forming the  $R_B$  and  $R_J$  back surfaces, besides the effect of the chipping process we have to consider mainly the effect of the resharpening of the tool (the insurance of profile accuracy). Since the hobs have complicated geometry and are expensive tools, it is important to ensure that the tool could be resharpened several times when we elaborate the geometry of the tool [1, 3].

### 3. DEFINING OF BACKWARD TURNING

A backward turned curve is called that curve in which the back surfaces of the cogs of the hob are found. They have to content two conditions in whichever perpendicular section of figure hob axis:

- a) The measured profile height in radial direction can not be changed along the curve from the back surface.
- b) The  $\alpha$  back angle can not be changed in whichever profile point of tool.

The backward turning is radial directional, the perpendicular section for the hob axis of the back surface gives the backward turned curve. This back surface is prepared by the shaping surface (figure knife) such during workpiece turning it does radial direction motion [2]. Such prepared backward motion is repeated in many times as many tool has cog.

The backward turning have to be done such curve, in which tangent to curve closes constant  $\beta$  angle with radial direction in one random point of the curve, which suitably the  $\alpha$  back angle is constant. This is the logarithm spiral (Figure 4).

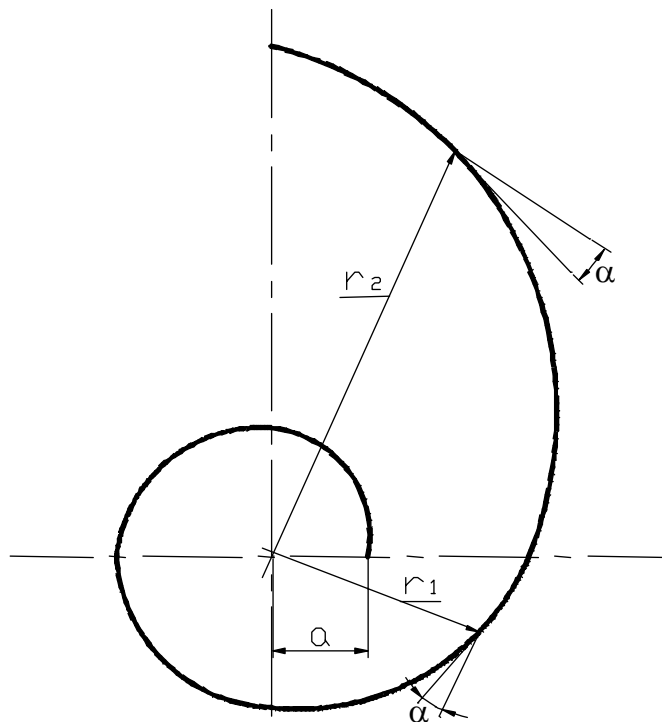

Figure 4. Logarithm spiral

#### 4. MATHEMATICAL ANALYSIS OF LOGARITHM SPIRAL

Given from the structure of the backward turning machine, is created the required shape in polar coordinate system, that is certain angle defection appertains to certain radial directional moving, that is why we create the equation of the curve in polar coordination shape [4].

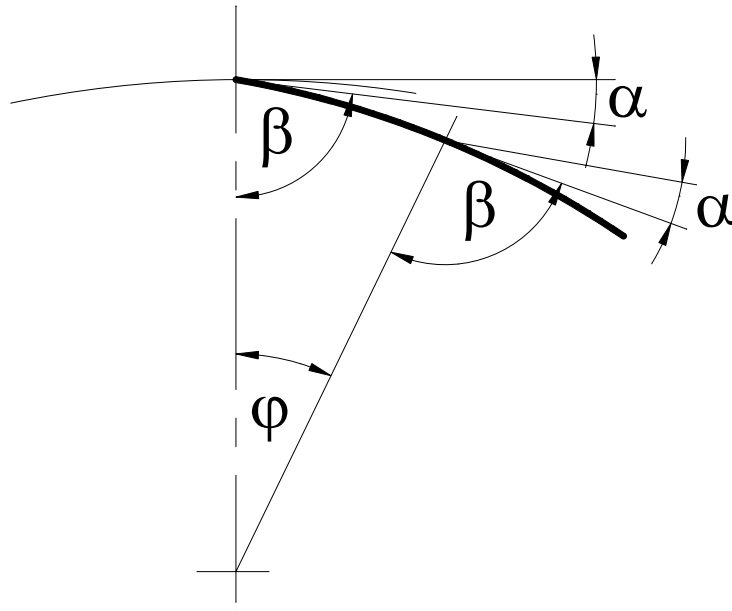

Figure 5. Conceptual figure of logarithm spiral

Based on well known proposition in mathematics the tangent  $\beta$  angle between the tangent and the radius vector can be defined such we compose the quotient of the function and the first differential quotient. If  $f(\varphi) = r$ , then:

$$\operatorname{tg}\beta = \frac{r}{\frac{dr}{d\varphi}} = \frac{1}{\operatorname{tg}\alpha} \quad (1)$$

Namely:

$$\operatorname{tg}\beta = \operatorname{tg}(90^\circ - \alpha) = \frac{1}{\operatorname{tg}\alpha} \quad (2)$$

Regulated the (1) equation is:

$$\operatorname{tg}\alpha = \frac{dr}{r \cdot d\varphi} \quad (3)$$

If we introduce the  $m = \operatorname{tg}\alpha$  nomination and receive  $\alpha$  angle constant, which is our condition, because it gives the constantly back angle, then  $\operatorname{tg}\alpha = m = \text{constant}$ . It is substituted to (3):

$$d\varphi \cdot m = \frac{dr}{r} \quad (4)$$

After that we integrate both sides:

$$m \cdot \int d\varphi = \int \frac{dr}{r} \quad (5)$$

Which is in conclusion:

$$m \cdot \varphi + c = \ln r \quad (6)$$

That is:

$$e^{m \cdot \varphi} \cdot e^c = r \quad (7)$$

or:

$$r = a \cdot e^{m \cdot \varphi} \quad (8)$$

Where the  $e^c = a$  or  $\ln a = c$  (Figure 4). The  $a$  is obviously constant value and if  $\varphi = 0$  then  $a = r$ . Such gained equation is the polar equation of logarithm spiral (Figure 4). Where:

- $r$  – radius vector;
- $a$  – constant (if  $\varphi = 0$ , then  $r=a$ );
- $m$  – constant exponent ( $m = \operatorname{tg} \alpha$ );
- $\alpha$  – the angle which is closed by radius vector on one random point and the polar axis on the curve, - constant angle which is closed by the tangent of curve and the perpendicular line for radius vector (back angle).

The logarithm spiral can be established on the largest distance of the profile form the turning axis. The backward turning curve of the whichever farther point of the profile will be such curve, which its every point is equal distance from the original logarithm spiral, which is called conchoid of this logarithm spiral.

The  $\alpha$  angle value changing is such insignificant, after sharpening the hob profile is in tolerance level that is why the logarithm spiral can be used.

## 5. PRODUCTION OF BACKWARD TURNED HOB

The production of the hobs is fairly complex, punctual and precise task. In Figure 6 the different production stage of the hob can be seen:

- $a$  dressing turning;
- $b$  flute milling;
- $c$  head surface grinding;
- $d$  backward turning.

The backward turning of hob cogs is prepared along logarithm spiral, which is shown by long chain in Figure 6.

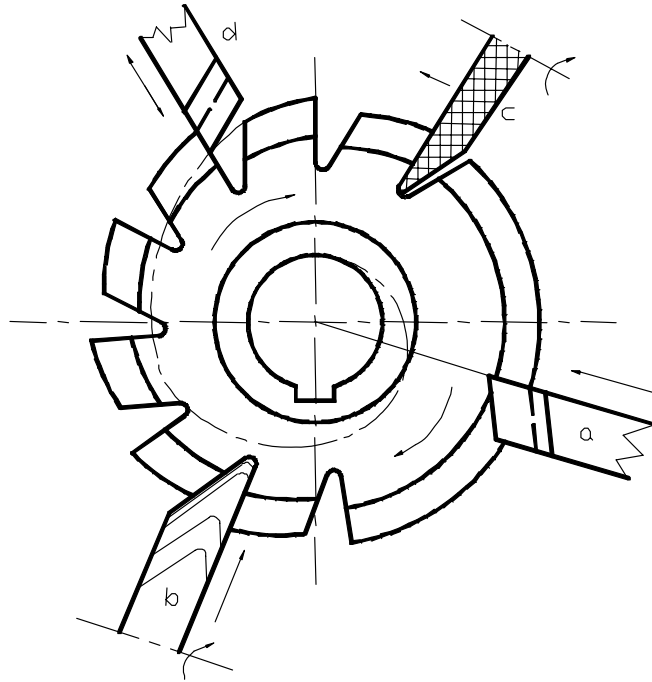

Figure 6. Production of backward turned hob

## 6. DEFINING OF DIMENSION OF BACKWARD TURNING

The most important element in backward turning is defining of the  $h$  dimension of backward turning. This  $h$  dimension characterized the needed radial cam for backward turning [1]. The dimension of backward turning is same in one cog pitch and regarded to such cog pitch it can be defined based on Figure 7 nominations. Length of arch for one cog pitch on the largest perimeter is:

$$i = \frac{D \cdot \pi}{z} \quad (9)$$

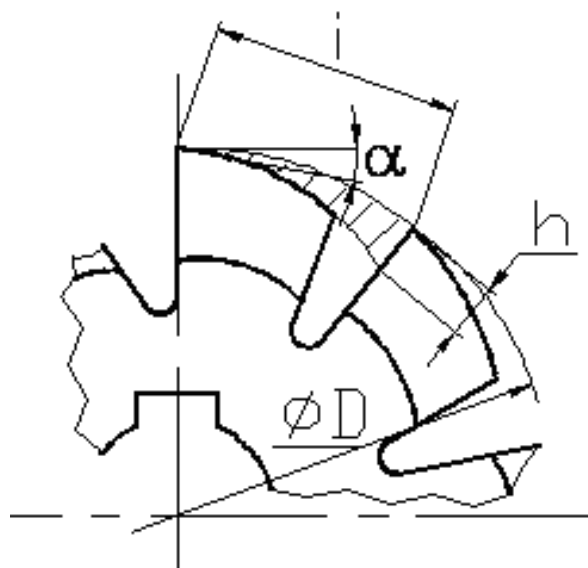

Figure 7. Defining of dimension of the backward turning

Calculation with average  $\alpha$  back angle straightening the shaded curve triangle is:

$$\operatorname{tg} \alpha = \frac{h}{i} = \frac{h \cdot z}{D \cdot \pi} \quad (10)$$

From this is:

$$h = \frac{D \cdot \pi}{z} \cdot \operatorname{tg} \alpha \quad (11)$$

## SUMMARY

Only such tools could be used for high precision machining of shaping surfaces, the profiles of which do not change at resharping or the dimension of profile changes is in the tolerance level. The backward turned hobs are appropriate for this purpose.

It could be ensured with resharping along logarithm spiral, profile without deformation could be given in axial plane and the back angle of the cogs of the hob is to be constant along the backward turned curve. These conditions are indispensable for the high precision, long life working of the tool. The main production parameter in backward turning is the  $h$  dimension of backward turning. This  $h$  dimension characterized the needed radial cam for backward turning. That is why defining of  $h$  dimension is important.

## REFERENCES

- [1] **DR. DUDÁS ILLÉS:** Gépgyártástechnológia III. Miskolci Egyetemi Kiadó, 2005 (ISBN 963 661 572 1)
- [2] **DR. DUDÁS ILLÉS:** The Theory and Practice of Worm Gear Drives. Penton Press, London, 2000. (ISBN 1 8571 8027 5)
- [3] **DR. DUDÁS ILLÉS:** Fogazószerszámok fejlesztésének tendenciái hengeres és kúpos lefejtőmaró gyártásgeometria elmezése, NME, Miskolc
- [4] **SASI NAGY ISTVÁN:** Fogazószerszámok tervezése, Budapest, Műszaki könyvkiadó, 1961.