

# PRICE TRANSMISSION AND ITS ANALYSIS IN THE MILK AND DAIRY SECTOR: A SURVEY

Mészáros, Sándor<sup>1</sup> – Popovics, Péter András<sup>2</sup>

## Abstract

Price transmission is used by agricultural economists to examine market efficiency especially in the food sectors (product lines). The article offers a survey on the accomplishments since Gardner's study (1975) marking a milestone in the science. It concentrates especially to the approach and measure of price transmission, the dairy sector, and competition being the most influential factor. Much of the literature claims that in developed countries market structure in food industry is characterized by oligopoly, and trading sector has a significant market power that is growing in Europe. Therefore, price transmission between farmers and retailers is imperfect, asymmetric and lagged. Certainly, besides market power, price transmission is influenced by several factors. A deciding factor is whether the current situation in the market is controlled by supply-push or demand-pull. Furthermore, even statistical tests for price transmission have problems, too. For this reason, authors make suggestions for the followings: the purposes of price transmission analyses, comparisons of its measures, verification of its tests on the same objects and ways of using it in economic policy.

**Keywords:** price transmission, elasticity, asymmetry, competition, market power, dairy sector.

## The concept of price transmission

The concept of price transmission means a complex price impact, during which the prices of several products or sectors (markets) have an effect on one another, the determining (starting) prices pass through to either direction, making economic interactions between the products or sectors concerned. Dhar and Cotteril (2002) refer to cost pass through rate as an alternative term for price transmission. Economists studying price transmission claim that these complex price impacts integrate different markets both vertically and horizontally (Meyer and Cramon-Taubadel 2003, Tóth 2003). If this fact applied, price transmission analyses would be widely used in studying the effectiveness of market functions. Nevertheless, extensive studies on the national economy are difficult to find (Peltzman 2000) in the paper surveying 38 works on price transmission tests conducted between 1980 and 2002, apart from food sector, only in the oil product and money transfer (interest rate) sectors can these types of studies be found (Meyer and Cramon-Taubadel 2003).

Presumably it is not by chance that price transmission studies are most widely happening to be conducted by agricultural economists. The theory first emerged in literature in the USA in the 50's (Hildreth and Jarett 1955). Nevertheless, in the book 'Agricultural Product Prices' by Tomek and Robinson (1972) the term 'price transmission' cannot be found yet, but George and King (1971) also use the term 'price transmission elasticity', and Gardner (1975) worked out an often-quoted theoretical model to look into interactions between farm prices and retail

---

<sup>1</sup> Research and Information Institute for Agricultural Economics, H-1355 Budapest 55. POB 5.  
e-mail: [emes@akii.hu](mailto:emes@akii.hu)

<sup>2</sup> University of Debrecen, Center for Agricultural Sciences, Faculty of Agricultural Business and Rural Development, Department of Agricultural Business and Economics, H-4032 Debrecen, Böszörményi str. 138.  
e-mail: [popovicspeti@freemail.hu](mailto:popovicspeti@freemail.hu)

prices. In the title of his article he employed the term 'price spread', referring to the widening of price margin (caused by price transmission); though in the discussion part he deduces price transmission elasticity. Wohlgenant (2001) considers farm-to-retail price spread as a synonym of marketing margin.

In agricultural economic literature studies concentrating on horizontal price transmission can also be found (eg. Bailey and Brorsen 1989, Mohanty et al. 1995, Abdulai 2000), however, studies on vertical price transmission are more typical. The reason is that farmers and consumers think that in processing and trading sectors linking them competition is imperfect and members of these sectors take advantage of their market power. They often give voice to their opinions, inducing congress representatives to order the General Accounting Office to examine price changes in the dairy sector (Nicholson and Novakovic 2001).

Certainly, studying price transmission is not the only way to determine whether joint markets are competitive or to analyse their operation. Nicholson and Novakovic (2001) suggest studying profit and margin as well for additional information. Still in literature the use of price transmission as an indicator for functioning of vertical markets is widespread. The reason might be the good availability of price data (in contrast to profit data); furthermore, working out the theory and the econometric methods of price transmission is a big challenge for economists.

Much of the literature examine whether price transmission is symmetric or asymmetric. Price transmission is symmetric if price increase or decrease in one market (for e.g. in the raw milk market) is followed by similar changes in the other market (for e.g. the bottled milk market). This similar reaction applies for the direction, the extent and the speed of price reactions. In other cases, price transmission is asymmetric. Some presumptions concerning price transmission are the following:

- Symmetric price transmission characterise competitive markets, while non-symmetric price transmission denotes that the market is non-competitive or imperfect.
- Perfect (complete) price transmission prevails rather in the long run, while asymmetric or incomplete price transmission is more frequent in the short run.
- Another important presumption deals with the direction of price transmission. If price is determined by suppliers (for e.g. dairy farmers), cost- push impulses are dominant in the process of price transmission. However, if price is determined by demand (for e.g. milk consumers), price transmission is determined by the demand-pull forces (Kinnucan and Forker, 1987).

Non-symmetric price transmission has several types:

- In the first type, the change in input and output price occurs simultaneously, asymmetry is caused by the difference in the extent of changes, as it is shown in Diagram 1.

If the input price decreases by a certain amount, the output price might decrease as well, but on a smaller scale. At the same time, increase in input price causes an increase in output price, in most cases on a higher scale.

**Diagram 1:** Asymmetry in the extent of price change

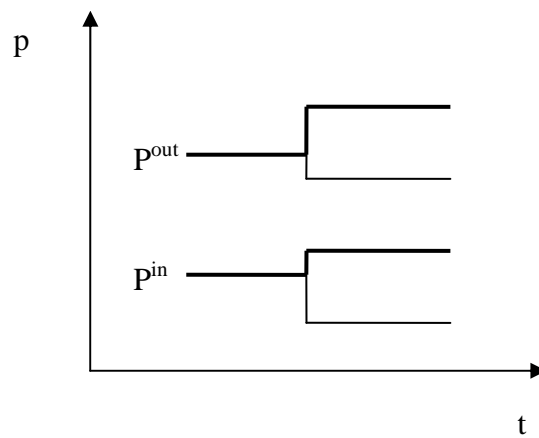

*Source: Meyer and Cramon-Taubadel 2003*

- In the second type, changes in input and output prices occur in different time, as shown in Diagram 2. The diagram shows price increasing and decreasing cases at same time. An increase in input price is immediately followed by the same extent increase in output price. However, if input price decreases, the speed of decrease in output price is lower. This delay enables a given segment of the sector possible to realize extra profit.

**Diagram 2:** Asymmetry in speed of price change

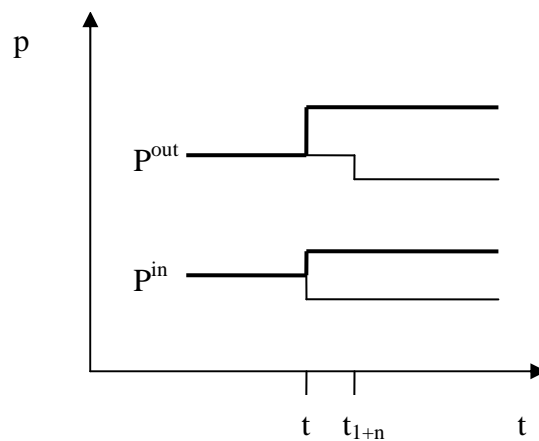

*Source: Meyer and Cramon-Taubadel 2003*

Usually the combination of these two types is common in practice, as shown in Diagram 3.

**Diagram 3:** Combination of asymmetry in extent and speed of price change

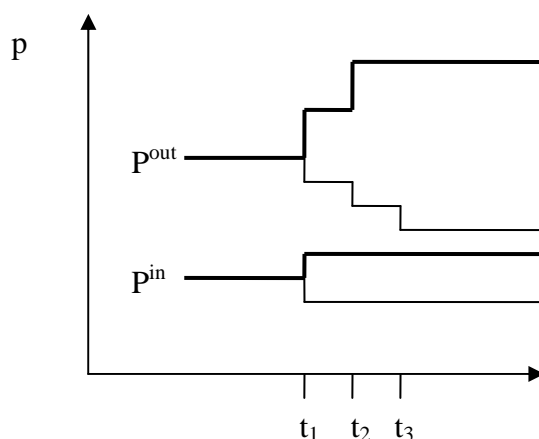

*Source: Meyer and Cramon-Taubadel 2003*

- In such a case, increase in input price causes an immediate increase in output price, which change is higher in degree but is extended in time and takes place in steps. Similarly, the decrease in input price takes place in output price, this change is higher in degree and is extended in the time and takes place in steps too.

This asymmetry can be positive or negative. **Positive asymmetry** means that output price follows input price at the same speed and at the same extent, but decrease at a lower extent. **Negative asymmetry** means that output prices follow the increase in input prices at the same speed and at a smaller extent, but follow the decrease at the same extent. (Kinnuchan and Forker 1987, Nicholson and Novakovich 2001)

To understand the problems of price transmission, some more concepts and interrelationships have to be discussed. The most important are the following:

Price transmission between agriculture and food consumption is highly influenced by the pricing mechanism of commerce. Here, periodic markup pricing is typical, which was first examined in details and tested for 22 food products by Heien (1980). Certainly, markup pricing have menu costs or repricing costs, so the commercial sector ceteris paribus has no interest in frequent price changes. This causes rigidity and inflexibility in food product prices. The concept of price rigidity is older than that of price transmission (Means 1935), though it is still in use. For e.g. Azzam (1999) studies price rigidity of commercial prices at firms in spatial competition. Certainly, price transmission can be examined regarding not only agricultural raw materials, but also the marketing costs of food products usually meaning the total of processing and trading costs (Romain et al. 2002).

Another reason for price transmission being non-symmetric or imperfect is the market power of the processing or retailing sector in the food business. New marketing theories and practices claim that within food supply chains price leadership of farmers (processors) has been taken over by retailers. Kuiper and Meulenberg (2002) studied Dutch food supply chains, in terms of vertical pricing. Furthermore, inflation rate can highly influence commercial behaviour. This fact has been pointed out by the price transmission analysis in Brazil (Aguilar and Santana, 2002). Given the high inflation rate, people could tolerate high

rises in prices, irrespectively of the economic power of the industries. Therefore in case of transition countries, this factor has to be taken into account. Apart from inflation, there are other factors influencing both the extent of price transmission and the impact of economic power: this is called returns to scale. McCorrison et al. (2000) point out that if returns to scale are not constant, it may offset the effect of economic power. From this point of view Millan (1999) examined the food market in Spain. He found that the returns to scale increased at each of the 16 industries being examined, except from bread and flour industry.

### **Measuring price transmission**

Price transmission analyses include qualifying its main characteristics including speed, extent and symmetry. (Palaskas 1995).

Price transmission elasticity index is of high priority in demonstrating the price transmission rate. As it is expressed %/%, it is easy to use in international comparisons. As regards food supply chain, usually the farm to retail price transmission is examined, where price transmission elasticity – putting it to common language – shows that if farm price increases (decreases) by 1 %, how much the consumer price of processed products would increase (decrease). This type of measure is usually supported by the implicit assumption of price transmission being one way and onward, moving from the farmer to the consumer.

In the food industry, Gardner (1975) was the first to theoretically examine (by means of mathematical deduction) the determining factors of price transmission elasticity, at competitive relations. In his model he assumed that in food marketing industry there is one output product (x) and two inputs: agricultural product purchased (a) and other marketing input (b), the latter including both processing and commercial costs. The model included 6 equations with 6 endogen variables (x, a, b quantitative variables and  $P_x$ ,  $P_a$ ,  $P_b$  price variables). The excellence of the article also comes from the fact that before measuring price transmission elasticity, it also examines the basic price indices in the supply chain. The article examined:

- the difference between consumer price and farm price ( $P_x - P_a$ ), called price gap by Tóth (2003)
- the ratio of these two prices  $P_x/P_a$
- the rate of farmer's share of the food dollar  $P_x/xP_a$
- the percentage marketing margin  $(P_x - P_a)/P_a$ .

Relative to the price transmission elasticity rate, Gardner found that it has to be determined on the bases of two situations (and formulas): if price changes derive from the agricultural supply,  $E_{P_x/P_a}$  is smaller than 1. However, if the price change is caused by a change in food demand, the elasticity of price transmission amounts approximately 1. Moreover, it can be even higher (if supply price elasticity of agricultural products exceeds that of other marketing inputs).

These estimations of Gardner have been confirmed by Kinnucan and Forker (1987). Using the same formulas, they found that in case of supply cost push price transmission elasticity ranged between 0.40-0.50 while if demand shifted price transmission elasticity ranged between 0.75-

1.50. Moreover, these authors published empirical data as well for different milk products. Their achievement is to differentiate between cases of price increases and decreases as well as short- and long term price transmission elasticities. In each case the price transmission elasticity was below 1. Coleman (1985) introduced the notion of 'perfect transmission' for price transmission elasticity being 1.

Palaskas (1985) used 3-step tests to study whether this perfect price transmission applies in the long run and also in the short run. In the first test he surveyed if time series of prices are non-stationary respectively. In the second test he examined whether time series are co-integrated, namely these are the two conditions necessary for long-term interaction between time series of prices. Therefore, he used the Dickey-Fuller (DF) or the augmented Dickey-Fuller (ADF) test (Dickey and Fuller, 1979, 1981). The third test was conducted to determine if price transmission elasticity,  $b=1$ , namely perfect price transmission applies. To find out, he calculated co-integrated regression, where statistical verification of the b-coefficients rates is performed by a maximum likelihood t-test. To summarize the analysis made for 7 EU member countries and 5 product lines they found that, contrary to the long run, usually perfect price transmission does not prevail in the short run. On the other hand, price transmission elasticity rates usually exceeded 1 (ranged between 0.85 and 2.08).

To determine another important feature of price transmission, i. e. whether it is symmetric or asymmetric, also different statistical tests are used. 4 group of methods have been worked out, today the first two are called pre-cointegration approaches (Meyer and v. Cramon-Taubadel 2003), the third is called error correction models (ECM), while the fourth is called threshold methods.

The function of price transmission can simply be put down as a one-variable, linear regression equation, supposing onward price imparts and as regards processors, symmetric and linear pricing behaviour. In this case the dependent variable is the price of the end-product (e.g. milk) the sole independent variable is the price of agricultural raw material (e.g. raw milk), while the regression coefficient embodies symmetric price transmission. To do the simplest price-symmetry test, this regression coefficient has to be split into two, introducing two dummy variables, which differentiate between cases of the increases and decreases in the price of the agricultural raw material. The significance in the divergence between the two regression coefficients is then checked by standard F-test. In agriculture, Tweeten and Quance (1969) introduced the differentiation between the regression coefficients according to the increase or decrease of price, by means of dummy variables (regarding supply functions).

Compared to this simplest test of price symmetry, improvements have already been made before the co-integration period. Instead of using original price data, Wolfram (1971) introduced the use of their first differences, when the recursive sums of the positive and negative price changes are the explanatory variables in the regression equation. Gollnick (1972) modified the regression equation by eliminating the summing procedure of the first differences. Houck (1977) and later Ward (1982) improved the specification of the price transmission equation. Ward introduced lags in the explanatory variables. Boyd and Brorsen (1988) differentiated these lags so that the magnitude and speed of price transmission could be distinguished.

Later v. Cramon-Taubadel (1998) pointed out that building the price symmetry test on this traditional specification of the regression equation above is not consistent with the fact that time series are co-integrated. The specification of the regression equation based on the first

differences leads to a misspecification of long term interaction of prices. To eliminate this problem, introduction of an error correction model (ECM) was suggested, first used in econometrics by Granger and Lee (1989).

The fourth group of methods include threshold models. Scientists set out from the approach that at later stages of a product line (in the processing industry, in commerce) price reactions are not linear, namely only occur if price impulses from the farmer exceed a critical threshold. Tong (1983) introduced threshold models in the studies of time series. Since then, the various threshold models have become more and more popular, for e.g. the Threshold Autoregressive model (TAR), (Ben-Kabia et al. 2002).

After comparing the 4 methods as regards the ratio of tests leading to non-symmetric price transmission, an interesting result has been given (Meyer and v. Cramon-Taubadel 2003). 38 different papers have been compared published between 1980 and 2002, including 197 individual tests. The number of tests and the rejection ratio for symmetric price transmission can be seen in the table below:

	<b>Number of cases</b>	<b>Price symmetry rejected (%)</b>
<b>All cases</b>	<b>197</b>	<b>48</b>
Out of which:		
1. Models using first differences	93	68
2. Models using the sums of first differences	47	23
3. Error correction models (ECM)	31	45
4. Threshold models	10	80

Thus, around half of the incidents examined resulted in non-symmetric price transmission. However, this general ratio fluctuates according to the test method used: it ranged between 23 and 80 %. The problem stems from the fact that there is no exact tendency between the rates of rejections at methods before (methods 1 and 2) and after (methods 3 and 4) co-integration. The rejection rates did not differ significantly in case of methods 2 and 3, and methods 1 and 4. This shows that the robustness of the test methods has not been proved yet. It would be necessary that different test methods being proved and compared for the same incidents. However, out of the 38 publications, only 3 studies complied with these requirements. Therefore, there is a good cause to continue methodological research in this direction.

### **Price transmission in the milk and dairy sector**

The most comprehensive study on the EU's dairy sector examining 2 decades and 7 countries between 1971 and 1990 has been done by Palaskas (1995). The study focused on price transmission between farm prices and consumer prices and besides the dairy sector, it also examined other product lines. The results are the following:

- The hypothesis of long term perfect price transmission ( $b=1$ ) could not be rejected in 17 out of the 35 cases (7 countries x 5 product lines). A similar 50-50 percentage ratio has been found in the dairy sector as well: in 7 out of the 14 cases (7 countries x 2 product lines) long term perfect price transmission prevailed. It also means that in the other half of the cases, price transmission was imperfect even in the long run.
- Within the dairy sector, the difference between the two product lines is significant: as regards milk and butter time series, long run perfect price transmission prevailed in 6 countries (except from the UK). However, as regards the milk-cheese product line, it prevailed only in one country (Belgium).
- Contrary to long run perfect price transmission, consumer prices change at a higher rate than farm prices: price transmission elasticity ranged between 0.89-1.68 in the milk-butter product line and 1.04-1.54 in the milk-cheese product line<sup>3</sup>.
- The hypothesis of short run perfect price transmission (that is lags being zero) has been rejected by statistical analysis, showing that consumer price reactions on changes in raw material prices are not instantaneous, but are distributed and lagged for months<sup>4</sup>.

In the USA this problem was examined earlier by using national data. Kinnucan and Forker (1987) studied the occurrences of rises and falls of raw material prices for 4 milk products between 1971 and 1981. The t-test disapproved the hypothesis of symmetric price transmission for each of the 4 products. Apart from that, the price transmission elasticity rates also confirmed the presence of non-symmetric price reactions in the retail sector: taking increasing prices for raw materials, they were systematically higher than in case of decreasing milk farm prices (for e.g. 0.46 instead of 0.33 for fluid milk, 0.71 instead of 0.42 for butter in the short run). Subsequent examinations of the national data also showed non-symmetric price transmission. (Nicholson and Novakovic 2001)

There are some more detailed new analyses including only one state instead of the whole of the USA. These studies can already consider the structure of markets or marketing channels. One of these studies is by Dhar and Cotteril (2002), who examined the Boston fluid milk market between March 1996 and July 1998; the period includes the increase and stabilization in raw milk farm price. The study is based on data gathered from 4 leading supermarket chains (Stop and Shop, Shaw's, Star Market, De Moulas) and has 3 points of interest:

1. It calculates price transmission between phases of the sectors differentiating between the processor-wholesaler and wholesaler-retailer phases.
2. It distinguishes between industry-wide and firm specific price (cost) impulse (shock) and transmission.
3. The study works with 3 models of behaviour of supermarket chains, results of them was published for the Stackelberg game. Farm price impulses (raw milk) pass through the processing and commercial phases almost perfectly, price transmission elasticity ranging from 0.878 to 0.999, not diverging significantly from 1.

---

<sup>3</sup> It is noticed that Dhar and Cotterill (2002) explain retail price grows exceeding price transmission by the application of the market power.

<sup>4</sup> According to Lamm and Westcott (1981) in the USA maximum six months is necessary for milk consumer prices to follow producer prices.



However, own price transmission elasticity ranges between 0.55-0.65 between processor and wholesaler phases, and between 0.54 and 0.62 for wholesaler and retailer phases. Cross price transmission elasticity measured on firms ranges between 0.14-0.23 in farm to wholesaler phases and between 0.16-0.26 for wholesaler to retailer phases. One of the final conclusions of the study is that around 1/3-2/3 of the increase in milk consumer price resulted by price stabilization of raw milk has widened the price margins of processors and traders. Another important finding is that a 100 % price (cost) transmission is a necessary, but not sufficient condition for an effective competition at industrial level. This statement is dealt with in more details in the next point.

Romain et al. (2002) examined the fluid milk market of New York State between 1980 and 1997. They divided the state into two regions, the New York City Region including 11 counties, and the Upstate New York Region including the remainder counties. Curiosities of the study include that besides price transmission for raw milk, it also studied price transmission for other marketing costs, moreover, it examined the problem with and without governmental regulation. During the studied period, regulations have been changed twice.

1. In 1987, market deregulation of NYC has opened the market to the leading milk dealer in New Jersey, while earlier it was protected by a system of licences.
2. Another change was the price gauging law introduced in 1991 stating that the retail price of fluid milk cannot be higher than double the price of raw milk.

While the first change in regulations concerned the NYC market only the second affected both. Before 1991, raw milk price transmission was asymmetric in the long run in both regions: if price increased, price transmission elasticity was 0.70 (NYC) and 0.62 (UNY), but if price decreased, it was only 0.30 (NYC) and 0.49 (UNY). After introducing the price gauging law, long-term asymmetry stayed significant only in the NYC market (0.52 when prices rose and 0.43 when prices fell), price transmission elasticity became symmetric in the UNY market (0.52 and 0.51). The other intervention, deregulation of the NYC market significantly decreased the marketing margin.

Price transmission lags also deserve some attention. Earlier studies demonstrated shorter lags: for fluid milk, 3 months by Kinnucan and Forker (1987) and 2 months by Emerick (1994). However, according to Romain et al. (2002), this period was 4-5 months. We point out that lags are influenced by the level of processing, as Kinnucan and Forker claim that only for milk and butter was the lagging period 3 months, for cheese and ice cream it was 6 and 5 month, respectively. The maximum period of consumer prices to adapt to raw milk price changes was 6 months according to Lam and Westcott (1981).

The restructuring and competitiveness of the Hungarian dairy sector has been studied by a number of persons (Szabó 1992, Gorton and Guba, 2001), moreover, Tóth (1999) even studied the price margin and its influential factors. Szabó and Tóth (1998) and Popovics (2003,a,b) studied also price transmission. Graph 4 shows trends of milk prices in Hungary between 1995 and 2003.

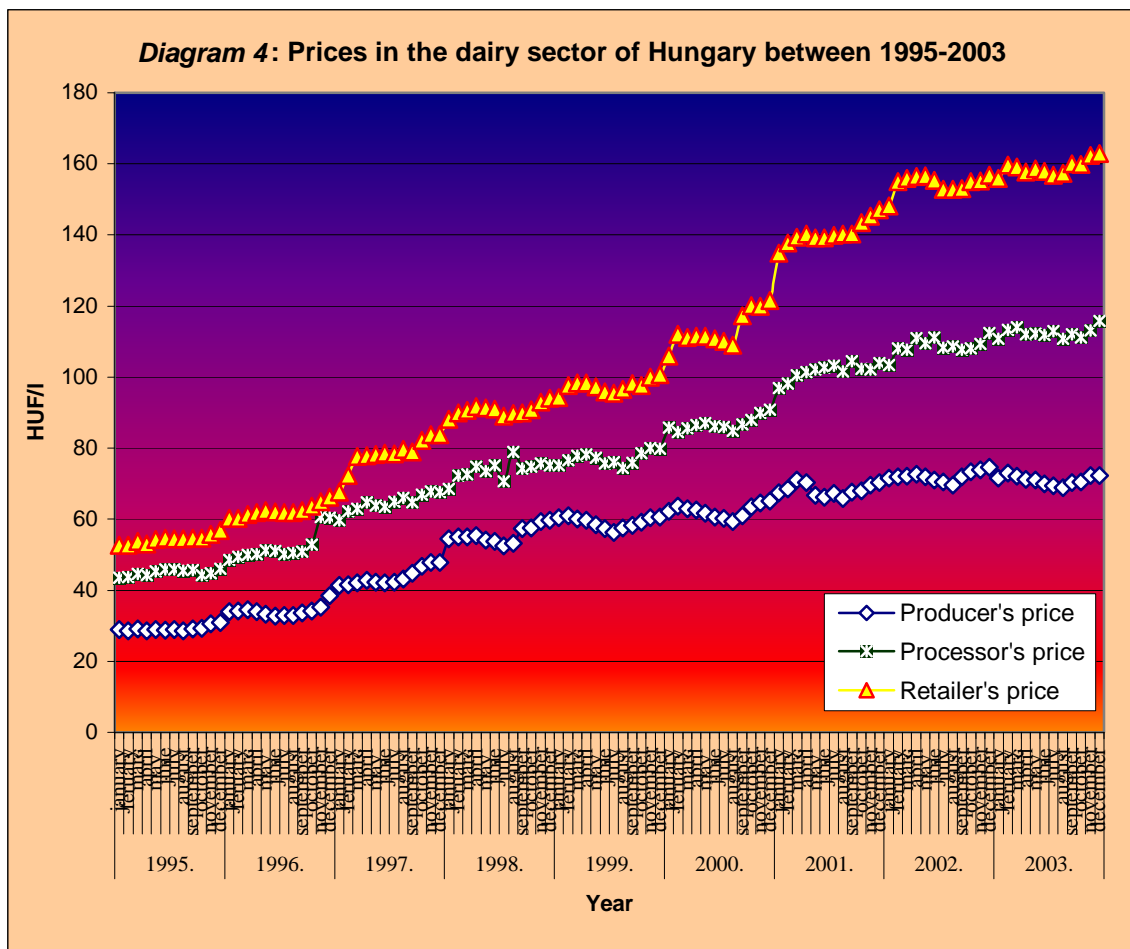

Source: Central Statistical Office of Hungary

### **Price transmission and competition**

As regards relationships between price transmission and competition, or with markets being competitive versus non-competitive only qualitative statements and assumptions have been found in literature. E.g. Gardner (1975) studied price transmission assuming perfect competition and price spread in the food product line. Kinnucan and Forker (1987), using Heien's (1980) approach found the assumption of competitive markets least defensible, explaining by marketing channels in the milk product lines being concentrated.

Holloway (1991) made an oligopolic generalization of Gardner's model. In his formula, he worked out 3 conditions for perfect competition in the consumer's food markets and used this generalized model to conduct empirical research into 8 food product lines in the USA. The results indicated that between 1955 and 1983 departures from perfect competition had been insignificant, including the milk sector as well. As for empirical studies on competition, most of the studies have been conducted in the USA, but agreement still has not been made whether food product lines are competitive or non-competitive.

Today, Clark and Reed (2002) are the strongest representatives of the opinion of competitive operation of food product lines in the USA. They claim that neither growing marketing margins, nor higher concentration level are evidence for market power. Therefore, they worked out a method to test market power directly. Even Meyer and Cramon-Taubadel (2003)

claim that concentration measures being used to prove market power are not perfectly correlated with the letter. They used the model for the relationship between farm prices and retail prices of Wohlgenant (1999). This model starts from the fact that price transmission elasticity equals with the farmer's share of the food dollar, but this statement applies only if the food industry is competitive and has constant returns as regards the agricultural raw materials being used. Wohlgenant's model helps to test whether price transmission elasticity equals with the mentioned farmer's share of the food dollar at changing production ratios. They tested 7 food sectors at an aggregated level of the USA. The results, including the milk sector did not disapprove that industries are competitive in the long run (except from the fresh fruit and vegetable sector). However, authors emphasize that further research is necessary to make a general statement concerning the presence of market power.

Many authors disagree with the previous statement, especially those studying only one product line in one state, contrary to taking the whole USA as a federal state. Azzam (1999) is one of the members of this "opposing party". In his theoretical work, he analyzed relationships among competition, pricing, price rigidity and price transmission in the retail sector. As regards imperfect competition in the milk sector, the work of Cotteril et al. deserves attention.

Cotterill (2000) pointed out that the degree of vertical competition influences cost pass through rate or price transmission rate. Moreover, he showed that in the USA (and also in Europe) food sector can be described by the successive monopoly model, where 'gross margin expansion via increased exercise of market power is the only fundamental strategy available to increase stock prices' in the retail sector.

In one of his new surveys presented to the Connecticut state legislation, Cotteril (2003a) proved that as milk marketing channels are non-competitive, milk prices are non-competitive as well and processors and retailers set prices on behalf of their own interest in New England. This is demonstrated by data regarding the southern region of the state: consumer price is approx. 3 dollar/gallon out of which only 1 dollar goes to the farmer. Costs of processing and trading (including a competitive profit) also amounts 1 dollar. The remainder 1 dollar extra profit goes to the processors and traders. Cotteril (2003b) emphasises that this New-England-type pricing practice does not apply to the whole of the USA, but is common in many states, including Seattle and Chicago. We have to add that the current situation has aroused only a few years ago, and a drastic drop in the farm price of milk has also contributed to the problem.

In Europe, most of the studies regarding relationships between price transmission and competition have been conducted by McCorrison et al. from the UK. Back in 1998, they reported that market power decreases price transmission rate. (McCorrison et al. 1998). Later they found that there is a growing literature proving that food industry in developed countries is oligopolic. (McCorrison et al. 2001). At the same time, growing returns to scale increases price transmission rate. (Therefore, the shape of the industry-wide cost function is of high importance). They emphasized that in case of decreasing farm prices, price transmission rate is determined by demand side. In their calculation, the price transmission elasticity rating 0.51 at perfect competition dropped to 0.32 at imperfect competition (assuming constant returns to scale and linear demand function). In another new article, McCorrison (2002) drew attention to growing market power in the food industry in Europe. Furthermore, he referred to some factors influencing price transmission elasticity, including some new ones that have not been studied yet (e.g. the effect of vertical contracts). In their newest article (Lloyd et al. 2003) a

calculation presents that price transmission elasticity changed from 1, which is characteristic of a competitive situation to 1.4 in oligopolic or oligopsonic circumstances, in case the demand function shifts. This makes Palaskas's (1995) results for price transmission rates of EU member countries easier to understand.

In Europe, empirical studies have been conducted to solve problems of presence of market power. In Spain, Millan (1999) analysed the cost structure and market power of 18 food industries using Lerner's index between 1878 and 1992. He rejected the long-term equilibrium hypothesis regarding almost every industry. In France, Gohin and Guyomard (2000) analysed the pricing behaviour and oligopoly-oligopsony power in the retail sector for 3 groups of products, including milk. They rejected the idea of French food trading companies being competitive and showed that 20 % of retail to wholesale price margin in milk products derive from the oligopol and oligopson price distortions. In Germany, Herrmann and Möser (2003) studied price rigidity and price variability regarding 6 retailers using scanner data of the 144 weeks between 1996 and 1999. The study included 20 breakfast products, out of which they studied 4 in details. On the grounds of the law of one price, similar price rigidity is expected for similar brands regarding the 6 firms. Contrary to this, price rigidity varied significantly and pricing was not uniform, which, according to the authors, is an indicative of market power and this fact has to be considered in future price transmission researches. Finally, we point out that a detailed article reviewing the competition policy in the EU's agribusiness sector exists (Buccirossi et al. 2002), and the authors claim that the European Commission has been taking up competition problems only since 2000. One interesting point of the article is that it estimates the position of all the 4 parties (input-suppliers, farmers, producers, traders), on the other hand, it refers to the literature differentiating already 4 competition problems (selling market power, buying power, countervailing power, double marginalization).

### **Some conclusions**

For future research, authors give the following conclusions:

1. When examining price transmission, setting clear objectives is important. If the aim of the study is only to measure price transmission in a joint market, concentrating on exact quantification and diagnosis is sufficient, giving up examining the influencing factors. However, if detecting market power is one of the objectives, some alternative measures and the analysis the most important influencing factors cannot be dispensed with.
2. Research should try to compare price transmission elasticity rates published in literature. Clarification of the normative measures of price transmission elasticity ( $b=1$  versus the farmer's share of the food dollar) should be considered for the situation of perfect price transmission and perfect competition.
3. Statistical robustness of the different tests should be clarified on some objects, and more econometric methods should be compared on the same object, as it is usual in other disciplines. (Butler et al. 2004)
4. To promote utilization of price transmission results in economic policy, further studies are necessary to diagnose the role of price transmission studies in market efficiency, furthermore, to examine its relationships with the effects of government interventions.

## REFERENCES

- Abdulai, A (2000):** Spatial price transmission and asymmetry in the Ghanaian maize market. *Journal of Development Economics* 63: 327-349
- Aguiar, D. R. D. and Santana, J. A. (2002):** Asymmetry in farm to retail price transmission: evidence from Brazil. *Agribusiness* 18: 37-48
- Azzam, A. M. (1999):** Asymmetry and rigidity in farm-retail price transmission. *American Journal of Agricultural Economics* 81: 525-533
- Bailey, D. and Brorsen, B. W. (1989):** Price asymmetry in spatial fed cattle markets: *Western Journal of Agricultural Economics* 14 (2): 246-252
- Ben-Kaabia, M., Gil, J. M. and Boshnjaku, L. (2002):** Price transmission asymmetries in the Spanish lamb sector. Paper for the 10<sup>th</sup> congress of EAAE, Zaragoza (Spain).
- Boyd, M. S. and Brorsen, B. W. (1988):** Price asymmetry in the U.S. pork marketing channel. *North Central Journal of Agricultural Economics*, 10: 103-109
- Buccirossi, P., Marette, S. and Schiarina, A. (2002):** Competition policy and the agribusiness sector in the European Union. *European Review of Agricultural Economics* 29: 373-397
- Butler, K. , Field, C., Herbinger, C.M. and Smith, B.R. (2004):** Accuracy efficiency and robustness of four algorithms allowing full sibship reconstruction from DNA marker data. *Molecular Ecology* 13: 1589-1600
- Clark, J. S. and Reed, A. J. (2000):** Structural change and tests of market power in the US food industry. Paper at “The American Consumer and Changing Structure of the US Food Industry.” conference, Washington DC, May 2000
- Colman, D. (1985):** Imperfect transmission of policy prices. *European Review of Agricultural Economics* 12: 171-186
- Cotterill, R. W. (1999):** Dynamic explanations of industry structure and performance. Paper at USDA conference “The American Consumer and the Changing Structure of the Food System.” Washington DC, May 3-5, 2000
- Cotterill, R. W. (2003a):** Dairy policy for New England: options at the state and regional level. Testimony before the Committee on the Environment Connecticut Legislature.
- Cotterill, R. W. (2003b):** Fluid milk market channel pricing: monopolistic pricing by retailers hurts processors, farmers, consumers and federal market order pricing. *Food Marketing Policy Issue Paper No. 40*, University of Connecticut.
- V. Cramon - Taubadel, S. (1998):** Estimating asymmetry price transmission with the error correction representation: an application to the German pork market. *European Review of Agricultural Economics* 25: 1-18

- Dhar, T. P. and Cotterill, R. W. (2002):** Price transmission in differentiated product market channels: a study of the Boston Fluid milk market and the North East Dairy Compact. Food Marketing Policy Center Research Report No. 67. University of Connecticut
- Dickey, D. A. and Fuller, W. A. (1979):** Distribution on the estimators for autoregressive time series with a unit root. *Journal of American Statistical Association* 74: 427-431
- Dickey, D. A. and Fuller, W. A. (1981):** Likelihood ratio statistics for autoregressive time series with a unit root. *Econometrica* 49: 1057-1072
- Emerick, P. A. (1994):** An econometric analysis of dairy market price transmission processes. MS thesis, Cornell University
- Gollnick, H. (1972):** Zur statistischen Schätzung und Prüfung irreversibler Nachfragefunktionen. *Agrarwirtschaft* 21: 227-231
- Gardner, B. L. (1975):** The farm-retail price spread in a competitive food industry. *American Journal of Agricultural Economics* 57: 399-409
- George, P. S. and King, G. A. (1971):** Consumer demand for food commodities in the United States with projections for 1980. *Giannini Foundation Monograph* 26 (Mar. 1971)
- Gohin, A. and Guyomard, H. (2000):** Measuring market power for food retail activities: French evidence. *Journal of Agricultural Economics* 51: 181-195
- Gorton, M. and Guba, F. (2001):** Foreign Direct Investment (FDI) and the restructuring of the Hungarian dairy processing sector. *Journal of East-West Business* 7: 5-28
- Granger, C. W. J. and Lee, T. H. (1989):** Investigation of production sales and inventory relationships using multicointegration and non-symmetric error correction models. *Journal of Applied Econometrics* 4: 135-159
- Heien, D. M. (1980):** Markup pricing in a dynamic model of the food industry. *American Journal of Agricultural Economics* 62: 10-18
- Herrmann, R. and Möser, A. (2003):** Price variability or rigidity in the food-retailing sector? Theoretical analysis and evidence from German scanner data. Paper at the 25<sup>th</sup> conference of IAAE, Durban, 16-22 August 2003
- Hildreth, C. and Jarett, F.G. (1955):** A statistical study of livestock production and marketing. *Cowles Commission Monograph* No. 15. John Wiley and Sons, Inc., New York.
- Holloway, G. J. (1991):** The farm-retail price spread in an imperfectly competitive food industry. *American Journal of Agricultural Economics*, 73: 979-989
- Houck, J. P. (1977):** An approach to specifying and estimating nonreversible functions. *American Journal of Agricultural Economics*, 59: 570-572
- Kinnuchan, H.W., Forker, O.D. (1987):** Asymmetry in farm-retail price transmission for major dairy product, *American Journal of Agricultural Economics*, 69: 285-292

**Kuiper, W. E. and Meulenber, M. T. G. (2002):** Vertical price leadership: a cointegration analysis. *Agribusiness* 18: 317-331

**Lamm, R. M. and Westcott, P. C. (1981):** The effects of changing input costs on food prices. *American Journal of Agricultural Economics*, 63: 187-196

**Lloyd, T., McCorrison, S., Morgan, C.W. and Rayner A. J. (2003):** The impact of food scares on price transmission in inter-related markets. Paper at the 25<sup>th</sup> conference of IAAE, Durhan, 16-22 August 2003

**McCorrison, S., Morgan, C. W. and Rayner, A. J. (1998):** Processing technology, market power and price transmission. *Journal of Agricultural Economics* 49: 185-201

**McCorrison, S., Morgan, C. W. and Rayner, A. J. (2000):** Price transmission and the interaction between market power and returns to scale. *European Review of Agricultural Economics* 28: 143-160

**McCorrison, S. (2002):** Why should imperfect competition matter to agricultural economists? *European Review of Agricultural Economics* 29: 349-371

**Means, G. (1935):** Industrial prices and their relative inflexibility Senate Discussion Paper 13, 74<sup>th</sup> U.S. Congress, 1<sup>st</sup> session.

**Meyer, J. and Cramon-Taubadel, S. von (2003):** Asymmetric price transmission: A survey. Paper presented at the 10<sup>th</sup> EAAE conference in Zaragoza. [www.jochenmeyer.de/pdf/meyer-cramon.pdf](http://www.jochenmeyer.de/pdf/meyer-cramon.pdf)

**Millan, J. A. (1999):** Short-run equilibrium and market power in the Spanish food, drink and tobacco industries. *European Review of Agricultural Economics* 26: 229-243

**Mohanty, S., Peterson, E. W. and Kruse, N. C. (1995):** Price asymmetry in the international wheat market. *Canadian Journal of Agricultural Economics* 43: 355-366

**Nicholson, C. F. – Novakovic, A. M. (2001):** Farm to retail price relationships for fluid milk and dairy products. The Dairy Web let Series, Cornell Program on Dairy Markets and Policy <http://www.cpdmp.cornell.edu>

**Palaskas, T. B. (1995):** Statistical analysis of price transmission in the European Union. *Journal of Agricultural Economics* 46: 61-69

**Peltzman, S (2000):** Prices rise faster than they fall. *Journal of Political Economy* 108 (3): 466-502

**Popovics, P. A. (2003a):** Ártranszmisszió vizsgálat a tejvertikumban. Agrárgazdaság, vidékfejlesztés és agrárinformatika az évezred küszöbén c. nemzetközi konferencia, Debrecen, 2003

**Popovics, P. A. (2003b):** Price transmission analysis in the Hungarian dairy sector in the 1990s. Erdei Ferenc II. tudományos konferencia, Kecskemét, 2003

**Romain, R., Doyon, M. and Frigon, M. (2002):** Effects of state regulations on marketing margins and price transmission asymmetry: evidence from the New York City and Upstate New York fluid milk markets. *Agribusiness* 18: 301-315

**Szabó, M. (1992):** Vertikális koordináció a magyar tejgazdaságban (Vertical co-ordination in the dairy sector in Hungary). *Közgazdasági Szemle* 39: 279-288.

**Szabó, M. – Tóth, J (1998):** Agricultural Market Development and Government Policy in Hungary: The Case of the Milk/Dairy Sector Study for the World Bank, Maw script, 59p.

**Tomek, W. G. and Robinson, K. L. (1972):** Agricultural Product Prices. Ithaca and London: Cornell University Press.

**Tong, H. (1983):** Threshold Models in Non-Linear Time Series Analysis. New York, Springer Verlag.

**Tóth, J. (1999):** Market development in the Hungarian dairy sector. In: Food Processing and Distribution in Transition Countries: Problems and Perspectives (eds. Hartmann, M. and Wandel, J.) Wissenschaftsverlag Vauk Kiel KG, 1999, 63-77.

**Tóth J. (2003):** Aszimmetrikus árhatások az osztrák húsiparban – hazai tanulságokkal. *Közgazdasági Szemle*, L. évf. (4): 370-380.

**Tweeten, L. G. and Quance, C. L. (1969):** Positivistic measures of aggregate supply elasticities: some new approaches. *American Journal of Agricultural Economics* 51: 341-352.

**Ward, R. W. (1982):** Asymmetry in retail, wholesale and shipping point pricing for fresh vegetables. *American Journal of Agricultural Economics*, 62: 205-212

**Wohlgenant, M. K. (1999):** Product heterogeneity and the relationship between retail and farm prices. *European Review of Agricultural Economics*, 26: 219-227

**Wohlgenant, M. K. (2001):** Marketing margins: empirical analysis. Pp. 933-970 In: *Handbook of Agricultural Economics* (eds. Gardner, B.L. and Rauser, G.C.) Elsevier, Amsterdam – London – New York – Oxford – Paris – Shannon – Tokyo.

**Wolfram, R. (1971):** Positivistic measures of aggregate supply elasticities: some new approaches – some critical notes. *American Journal of Agricultural Economics*, 53: 356-359