

Large non-Gaussianities in the Effective Field Theory Approach to Single-Field Inflation: the Bispectrum

Nicola Bartolo^{1,2}, Matteo Fasiello³, Sabino Matarrese^{1,2} and Antonio Riotto^{2,4}

¹ Dipartimento di Fisica “G. Galilei”, Università degli Studi di Padova, via Marzolo 8, I-35131 Padova, Italy

² INFN, Sezione di Padova, via Marzolo 8, I-35131 Padova, Italy

³ Dipartimento di Fisica “G. Occhialini”, Università degli Studi di Milano Bicocca and INFN, Sezione di Milano Bicocca, Piazza della Scienza 3, I-20126 Milano, Italy

⁴ CERN, Theory Division, CH-1211 Geneva 23, Switzerland

DFPD-2010-A-05 CERN-PH-TH/2010-076

E-mail: nicola.bartolo@pd.infn.it, matteo.fasiello@mib.infn.it, sabino.matarrese@pd.infn.it and riotto@mail.cern.ch

Abstract. The methods of effective field theory are used to study generic theories of inflation with a single inflaton field and to perform a general analysis of the associated non-Gaussianities. We investigate the amplitudes and shapes of the various generic three-point correlators, the bispectra, which may be generated by different classes of single-field inflationary models. Besides the well-known results for the DBI-like models and the ghost inflationary theories, we point out that curvature-related interactions may give rise to large non-Gaussianities in the form of bispectra characterized by a flat shape which, quite interestingly, is independently produced by several interaction terms. In a subsequent work, we will perform a similar general analysis for the non-Gaussianities generated by the generic four-point correlator, the trispectrum.

Contents

1	Introduction	2
2	The inflationary action up to third order in the effective theory approach	4
3	Solution to the equation of motion for the scalar degree of freedom	8
4	Amplitude of the primordial non-Gaussianity	11
4.1	Amplitudes from DBI-like interactions and first two curvature-generated terms	13
4.2	Amplitudes from curvature-generated novel interaction terms	14
4.3	Some general considerations on the amplitudes of non-Gaussianities . . .	16
5	The shapes of non-Gaussianities	17
5.1	Shapes from DBI-like interactions and first two curvature-generated terms.	19
5.2	Shapes from curvature-generated novel interaction terms.	22
5.3	Some general considerations on the shapes of non-Gaussianities	27
6	Conclusions	29

1. Introduction

The inflationary paradigm is central in modern cosmology as it naturally provides an explanation for long standing issues as the flatness and horizon problems. The simplest standard, single-field slow-roll models of inflation already nicely account for the scale invariant primordial power spectrum of the Cosmic Microwave Background (CMB) anisotropies [1, 2, 3, 4, 5, 6]. On the other hand, in order to get a deeper understanding of the inflaton dynamics, one needs to consider observables sensitive to deviations from Gaussianity, which might be studied in the form of the three-point correlator of cosmological perturbations, the so-called bispectrum [7, 8, 10, 11], the connected four-point correlator, the so-called trispectrum [12], loop corrections to the power spectrum [13] and so on. In recent years, a lot of progress has been done in this direction resulting in the characterization of a wide variety of inflationary models through their higher order correlation functions [14].

Complementing this theoretical effort, new experiments provide a better sensitivity to deviations from Gaussian statistics (see, e.g. [17, 18]). The very recent launch of the Planck satellite [15, 16] (and the continued analysis of WMAP data [6]) presents us with the exciting opportunity to actually test this zoo of possibilities and makes more urgent the classification and refinement of the different predictions at the level of bispectrum and trispectrum of curvature perturbations (see, e.g., [19, 20, 21] for comprehensive and updated reviews).

In this context, the effective theory approach proposed in [22, 23] and further analyzed in [24] represents a powerful tool. Indeed, the effective Lagrangian approach provides an efficient way to generically study large classes of inflationary models. Furthermore, this formalism provides a clear-cut dictionary between deviations from the standard scenario (almost Gaussian perturbations) and higher-order invariant operators in the action; it sheds new light on effects due to symmetries in the action (notably, a reduced speed of sound often automatically results in an enhanced non-Gaussianity); it allows some general and immediate calculational advantages, by exploiting the so called decoupling regime; finally, one can classify almost any specific inflationary model switching on some particular operators in the Lagrangian, thus allowing a more unifying approach. The effective field theory formalism naturally comprises Lagrangians with higher order terms. These terms call for an UV completion of the underlying theory. In this perspective one looks with particular interest at string theory inspired models, such as DBI inflation [27], and possible explanations in this context for k-inflation models [25, 26].

They are retrievable in the effective theory approach as the effective field theory that lives in a particular region of the parameters space.

In the spirit of effective theory, one should also include all possible curvature-generated terms ($\delta R_{\mu}^2, \dots$) in writing the most generic effective theory Lagrangian of inflation up to the desired order in perturbation theory. In this paper we perform a thorough analysis of the amplitude and shapes of the three-point correlators which arise from the various classes of inflationary models driven by a single scalar field described within the generic effective theory approach. Besides reproducing the known results existing in the literature, that is to say that large non-Gaussianities may be generated if the sound speed is smaller than unity, we also show that single-field models of inflation may produce large non-Gaussianities in the form of three-point correlators whose amplitude is peaked in the so-called flat configuration, and precisely corresponding to a shape of the bispectrum where two of the momenta are roughly one half of the third one $k_1 = 2k_2 = 2k_3$. Such bispectra emerge from curvature-generated interactions that have not been discussed so far in the literature. Let us recall that a shape of this type, peaked on flat triangles, was first found in [38] where it was obtained as the result of a linear combination of two operators with proper weights ‡. We stress here that our results further expand the space of operators that generates this kind of shape and allow one to easily obtain it from different, independent operators. Before the results of [38], the only scenario compatible with such a flat shape (also called folded or squashed) for the primordial bispectrum was that of models of inflation which relax the assumption of a regular Bunch-Davies vacuum, as studied in [11, 28, 29]. In fact, up to [38], it was standard procedure to associate the primordial bispectrum evaluated in the Bunch-Davies vacuum to the so-called equilateral or local shapes [10].§ Here we

‡ It is important to note that these weights are not fixed, indeed there is an order one interval in [38] that produces shapes compatible with the flat template.

§ We refer to [30, 31] for a detailed analysis of possible shapes of the primordial bispectra and to the

highlight that such a flat configuration for the primordial non-Gaussianities might be generated in single-field models of inflation in a more general context than previously thought. It is worth pointing out another aspect in which our results differ from previous ones. We are able to provide a solution for the equations of motion of the primordial perturbations that can interpolate between known cases, like DBI or Ghost inflation. We are able to study in full generality these intermediate situations also when interaction terms are included. In a follow-up paper [32], we will perform a similar analysis for the trispectrum.

The paper is organized as follows. In section 2 we give a brief account on how to write the Lagrangian we employ in the following sections, following Ref. [23]. The reader who is familiar with this approach might wish to skip this part and jump directly to the third-order Eq. (13). We also comment on the inflationary models one can span within this approach and on the claim of its generality. The calculational algorithm used in this section can be extended to higher orders as well. In section 3 we derive the equation of motion for the scalar field which in the effective theory approach is used to describe the cosmological perturbations [33] and we provide an analytical solution to this general equation. In section 4 we present the calculation of the amplitude of the bispectrum for each interaction term in six different configurations capturing the simplest single field slow roll model, DBI inflation, ghost inflation and intermediate cases. We focus on regions in the parameter space where non-Gaussianity is large. In section 5 we study the shape of the bispectra arising from the individual interaction terms identifying, among other things, interesting shapes from the curvature-related contributions. We then summarize our findings and comment on further work in section 6.

2. The inflationary action up to third order in the effective theory approach

Our initial goal is to write down the complete theory of single-field models of inflation up to third order in perturbations. We will follow the effective theory approach first introduced in Ref. [23]. Let us give a brief summary of the procedure. The scalar field ϕ responsible for inflation is splitted as usual as an unperturbed part plus a fluctuating one:

$$\phi(\vec{x}, t) = \phi_0(t) + \delta\phi(\vec{x}, t). \tag{1}$$

One then chooses to work in the the comoving (or unitary) gauge for which $\delta\phi = 0$ [22]. The Lagrangian will no more be invariant under full spacetime diffeomorphisms (diffs) but only under the spatial reparametrizations. This is the starting point to write the most general space diffs invariant Lagrangian at the desired order in perturbation theory in an effective theory approach. In [23] the authors prove that, once an approximate shift-symmetry is operated, their second and third order action is the most general one (see also [24] for an interesting perspective on the most general effective Lagrangian for inflation). One can then use the Stueckelberg procedure to discussion in Ref. [38] for an approach that includes the flat shape. (see also Ref. [11]).

restore full spacetime invariance. As a by-product of this procedure, the degree of freedom hidden in the metric shows up again as a scalar field.

The most general space diffe-invariant action in unitary gauge is schematically written as [23]:

$$S = \int d^4x \sqrt{-g} F(R_{\mu\nu\rho\sigma}, g^{00}, K_{\mu\nu}, \nabla_\mu, t), \quad (2)$$

where $K_{\mu\nu}$ is the extrinsic curvature on which we will elaborate more later and the indices on g^{00} are free indices. Considering fluctuations around a FRW background amounts to studying the following action

$$S = \int d^4x \sqrt{-g} \left[\frac{1}{2} M_{\text{Pl}}^2 R + M_{\text{Pl}}^2 \dot{H} g^{00} - M_{\text{Pl}}^2 (3H^2 + \dot{H}) + \sum_{n \geq 2} F^{(n)}(g^{00} + 1, \delta K_{\mu\nu}, \delta R_{\mu\nu\rho\sigma}; \nabla_\mu; t) \right], \quad (3)$$

where the $F^{(n)}$ functions contain fluctuations which are at least quadratic. The next step is to restore full spacetime reparametrization invariance. To see how it works, we borrow a simple example from [23] and consider the following sample action terms

$$\int d^4x \sqrt{-g} [A(t) + B(t)g^{00}(x)] . \quad (4)$$

We are interested in time reparametrization $t \rightarrow t + \xi_0(\vec{x}, t)$; $\vec{x} \rightarrow \vec{x}$, under which the above action (after a simple variable redefinition) reads

$$\int d^4x \sqrt{-g(x)} \left[A(t - \xi_0(x)) + B(t - \xi_0(x)) \frac{\partial(t - \xi_0(x))}{\partial x^\mu} \frac{\partial(t - \xi_0(x))}{\partial x^\nu} g^{\mu\nu}(x) \right] . \quad (5)$$

Upon promoting ξ_0 to a field, $\xi_0(x) = -\pi(x)$ and requiring the following gauge transformation rule $\pi(x) \rightarrow \pi(x) - \xi_0(x)$ on π , the above action is invariant under full spacetime diffeomorphisms. The scalar degree of freedom π makes its appearance in the time dependence of the A, B coefficients and in the transformed metric. Furthermore, under time reparametrization the metric $g^{\mu\nu}$ transforms as follows:

$$\tilde{g}^{\alpha\beta} = \frac{\partial \tilde{g}^\alpha}{\partial x^\mu} \frac{\partial \tilde{g}^\beta}{\partial x^\nu} g^{\mu\nu} , \quad (6)$$

which implies

$$\begin{aligned} g^{ij} &\rightarrow g^{ij}; & g^{0i} &\rightarrow (1 + \dot{\pi})g^{0i} + g^{ij}\partial_j\pi; \\ g^{00} &\rightarrow (1 + \dot{\pi})^2 g^{00} + 2(1 + \dot{\pi})g^{0i}\partial_i\pi + g^{ij}\partial_i\pi\partial_j\pi. \end{aligned} \quad (7)$$

This procedure has been borrowed, conceptually unchanged, from standard gauge theory: a Goldstone boson which transforms non linearly under the gauge transformation provides the longitudinal component of a massive gauge boson. At sufficiently high energy such Goldstone boson becomes the only relevant degree of freedom. This is the so-called equivalence theorem. The same is true for our case: for sufficiently high energy the mixing with gravity becomes irrelevant and the scalar π becomes the only relevant mode in the dynamics. This is the so-called decoupling

regime. Let us clarify this concept with a simple example. Consider the following contribution, taken from Eq. (3)

$$M_{\text{Pl}}^2 \dot{H} g^{00} \rightarrow M_{\text{Pl}}^2 \dot{H} ((1 + \dot{\pi})^2 g^{00} + 2(1 + \dot{\pi}) g^{0i} \partial_i \pi + g^{ij} \partial_i \pi \partial_j \pi). \quad (8)$$

We focus on the quadratic part of the first term in the above equation. Upon canonical normalization, $\pi_c = M_{\text{Pl}} \dot{H}^{1/2} \pi$ and $g_c^{00} = M_{\text{Pl}} g^{00}$, one gets

$$M_{\text{Pl}}^2 \dot{H} (g^{00} + 2\dot{\pi} g^{00} + \dot{\pi}^2 g^{00}) = \dot{\pi}_c^2 + 2\dot{H}^{1/2} \dot{\pi}_c g_c^{00} + \dot{H} g_c^{00}. \quad (9)$$

Consider the second term of Eq. (9) which mixes gravity with the scalar. Since $\dot{\pi}_c \sim E \pi_c$, at energies higher than $\sim \dot{H}^{1/2}$ the term $\dot{\pi}_c^2$ dominates the dynamics. This turns out to be true in general: the number of derivatives (which in Fourier mode would basically give an energy-dependent coefficient in front of π) is higher in terms containing only π 's than in the mixed terms and therefore there exists an energy threshold above which the scalar decouples from gravity. Since in explicitating the $F^{(2)}$ term in Eq. (3) there can be, in principle, other quadratic terms that go like $\dot{\pi}^2$, one has to consider which one is the leading kinetic term and determine the canonically normalized field π_c and the energy threshold accordingly. To take the safe route, one might well take the energy threshold, E_{mix} , to be the highest one of this set. Since one is concerned with correlators just after horizon crossing, one concludes that the decoupling procedure works as long as the decoupling energy is smaller than the Hubble rate H . More precisely, we can anticipate that the kinetic terms in $F^{(2)}$ which are going to matter in our discussion come with coefficients M_2^4 and $M_{\text{Pl}}^2 \epsilon H^2$. The condition $E_{\text{mix}} < H$ is then satisfied if $M_{\text{Pl}}^2 \epsilon H^2 > M_2^4$, where $\epsilon = -\dot{H}/H^2$ is a slow-roll parameter; if this is not the case we need to assume $M_2^4 < M_{\text{Pl}}^2 H^2$.

From now on we will work in the decoupling regime. In considering the terms of Eq. (3), we will therefore use only the unperturbed entries of the metric tensor. To write the effective Lagrangian up to third order, we start from Eq. (3) and follow the algorithm given in [23]. Fluctuations are encoded in the $F^{(n)}$ terms. In order to be as general as possible, we also include all possible contributions up to third order coming from extrinsic curvature $K_{\mu\nu}$ terms. In fact, it is instructive at this stage to step back and consider the action in Eq. (2). Given a theory which is space diffeomorphism-invariant, one can always identify a slicing of spacetime, described by a timelike function $\tilde{t}(x)$, which realizes time diffeomorphism: on surfaces of constant \tilde{t} the time symmetry breaking scalar is also constant. Before selecting a gauge, there is still the freedom to make a choice on $\tilde{t}(x)$ and working in the unitary gauge amounts to requiring $\tilde{t} = t$. In order to describe the geometry of this preferred slicing, one employs the extrinsic curvature tensor. In writing down such a tensor, one needs two ingredients: the unit normal vector n_μ , perpendicular to the constant \tilde{t} surfaces and the induced metric $h_{\mu\nu}$. These are defined as

$$n_\mu = \frac{\partial_\mu \tilde{t}}{\sqrt{-g^{\mu\nu} \partial_\mu \tilde{t} \partial_\nu \tilde{t}}} \rightarrow \frac{\delta_\mu^0}{\sqrt{-g^{00}}}; \quad h_{\mu\nu} = g_{\mu\nu} + n_\mu n_\nu, \quad (10)$$

which allows us to write

$$K_{\mu\nu} \equiv h_\mu^\sigma \nabla_\sigma n_\nu = \frac{\delta_\nu^0 \partial_\mu g^{00}}{2(-g^{00})^{3/2}} + \frac{\delta_\nu^0 \delta_\mu^0 g^{0\sigma} \partial_\sigma g^{00}}{2(-g^{00})^{5/2}} - \frac{g^{0\epsilon} (\partial_\mu g_{\epsilon\nu} + \partial_\nu g_{\epsilon\mu} - \partial_\epsilon g_{\mu\nu})}{2(-g^{00})^{1/2}}. \quad (11)$$

The above expressions can be used to write explicitly the most generic third order action for the fluctuations around the FRW background within the effective theory approach of Ref. [23]:

$$\begin{aligned} S_3 = & \int d^4x \sqrt{-g} \left[\frac{1}{2} M_{\text{Pl}}^2 R + M_{\text{Pl}}^2 \dot{H} g^{00} - M_{\text{Pl}}^2 (3H^2 + \dot{H}) + \frac{1}{2!} M_2(t)^4 (g^{00} + 1)^2 \right. \\ & + \frac{1}{3!} M_3(t)^4 (g^{00} + 1)^3 - \frac{\bar{M}_1(t)^3}{2} (g^{00} + 1) \delta K^\mu{}_\mu - \frac{\bar{M}_2(t)^2}{2} \delta K^\mu{}_\mu{}^2 \\ & - \frac{\bar{M}_3(t)^2}{2} \delta K^\mu{}_\nu \delta K^\nu{}_\mu - \frac{\bar{M}_4(t)^3}{3!} (g^{00} + 1)^2 \delta K^\mu{}_\mu - \frac{\bar{M}_5(t)^2}{3!} (g^{00} + 1) \delta K^\mu{}_\mu{}^2 \\ & - \frac{\bar{M}_6(t)^2}{3!} (g^{00} + 1) \delta K^\mu{}_\nu \delta K^\nu{}_\mu - \frac{\bar{M}_7(t)}{3!} \delta K^\mu{}_\mu{}^3 - \frac{\bar{M}_8(t)}{3!} \delta K^\mu{}_\mu \delta K^\nu{}_\rho \delta K^\rho{}_\nu \\ & \left. - \frac{\bar{M}_9(t)}{3!} \delta K^\mu{}_\nu \delta K^\nu{}_\rho \delta K^\rho{}_\mu \right]. \quad (12) \end{aligned}$$

The coefficients M_2, M_3 and $\bar{M}_1, \dots, \bar{M}_9$ are to be considered generic. The \bar{M} coefficients multiply curvature-generated interactions. A given particular set of them will specify a given inflationary theory. The action (12) is not yet invariant under full diffeomorphisms though. One needs to follow exactly the steps illustrated in Eqs (4), (5) and (8) and promote ξ_0 to a field π with the proper gauge transformation.

In the decoupling limit we find:

$$\begin{aligned} S_3 = & \int d^4x \sqrt{-g} \left[M_{\text{Pl}}^2 \dot{H} (\partial_\mu \pi)^2 + M_2(t)^4 \left(2\dot{\pi}^2 - 2\dot{\pi} \frac{(\partial_i \pi)^2}{a^2} \right) - \frac{4}{3} M_3(t)^4 \dot{\pi}^3 \right. \\ & - \frac{\bar{M}_1(t)^3}{2} \left(\frac{-2H(\partial_i \pi)^2}{a^2} + \frac{(\partial_i \pi)^2 \partial_j^2 \pi}{a^4} \right) - \frac{\bar{M}_2(t)^2}{2} \left(\frac{(\partial_i^2 \pi)(\partial_j^2 \pi) + H(\partial_i^2 \pi)(\partial_j \pi)^2 + 2\dot{\pi} \partial_i^2 \partial_j \pi \partial_j \pi}{a^4} \right) \\ & - \frac{\bar{M}_3(t)^2}{2} \left(\frac{(\partial_i^2 \pi)(\partial_j^2 \pi) + 2H(\partial_i \pi)^2 \partial_i^2 \pi + 2\dot{\pi} \partial_{ij}^2 \pi \partial_j \pi}{a^4} \right) - \frac{2}{3} \bar{M}_4(t)^3 \frac{1}{a^2} \dot{\pi}^2 \partial_i^2 \pi + \frac{\bar{M}_5(t)^2}{3} \frac{\dot{\pi}}{a^4} (\partial_i^2 \pi)^2 \\ & \left. + \frac{\bar{M}_6(t)^2}{3} \frac{\dot{\pi}}{a^4} (\partial_{ij} \pi)^2 - \frac{\bar{M}_7(t)}{3!} \frac{(\partial_i^2 \pi)^3}{a^6} - \frac{\bar{M}_8(t)}{3!} \frac{\partial_i^2 \pi}{a^6} (\partial_{jk} \pi)^2 - \frac{\bar{M}_9(t)}{3!} \frac{1}{a^6} \partial_{ij} \pi \partial_{jk} \pi \partial_{ki} \pi \right]. \quad (13) \end{aligned}$$

A few clarifying comments are in order:

- If we consider terms only up to second-order, for $M_2 = \bar{M}_{1,2,3} = 0$ one recovers the usual quadratic Lagrangian for the fluctuations, with sound speed $c_s^2 = 1$ and the standard solution to the equations of motion. Switching on M_2 amounts to allowing models with sound speed smaller than unity, $1/c_s^2 = 1 - 2M_2^4/(M_{\text{Pl}}^2 \dot{H})$, which are often linked to a high level of primordial non-Gaussianity [11, 23]. Furthermore, turning on $\bar{M}_{2,3}$ in the de Sitter limit, one recovers Ghost inflation [35]. On the same lines, keeping all the \bar{M} 's vanishing, but going to third and higher order with the M 's, one can retrieve the interactions that describe DBI inflation [27, 11, 37]. The list of correspondences continues with K-inflation theories and others, thus showing

how the effective action approach provides a unifying perspective on inflationary models [23].

- The action in Eq. (13) has already been written with large non-Gaussianities in mind. This means that, at every order in fluctuations and for each M and \bar{M} coefficients, we have selected those leading terms which will eventually generate large three-point correlators. To clarify this point, we provide a simple example. Let us consider the terms up to second order in Eq. (13) and set conveniently $\bar{M}_{1,2,3} = 0$. The properly normalized solution to the equation of motion will be the usual $\pi_k(\tau) \propto iH e^{-ikc_s\tau}(1 + ikc_s\tau)$. It is straightforward to verify that, at the horizon crossing, $\dot{\pi} \sim H\pi$ and $\nabla\pi \sim H/c_s \pi$. Therefore, among the π terms with the same number of derivatives, the ones with the highest number of space derivatives dominate in the $c_s \ll 1$ limit. Generalizing these estimates for the classical solution (which we will describe below) obtained from the equation of motion of our complete action, one selects the terms in Eq. (13).
- there is also the comparison between same perturbative order but different M terms to be made. In the literature, all non zero coefficients in front of the various operators are generically assumed to be of the same order (see for example the discussion concerning the orthogonal configuration in Ref. [38] for an interesting perspective). We shall not restrict ourselves to this situation. Note that, were the coefficients to be all of the same order, one could already identify the dominant operators. For example, consider the third order contributions $\bar{M}_1^3(\partial_i\pi)^2\partial_j^2\pi/a^4 \sim M^3(H^4/c_s^4)\pi^3$; for $c_s \ll 1$ this will be a leading contribution with respect to, say, $\bar{M}_2(t)^2 H(\partial_i^2\pi)(\partial_j\pi)^2 \sim M^2 H(H^4/c_s^4)\pi^3$. This is due to the fact that in the effective Lagrangian every additional derivative comes with a $H/M \ll 1$ factor attached: one is basically doing an H/M expansion where M is roughly the energy range of the underlying theory. In the last example we have intentionally picked terms with the same power of c_s at the denominator. Let us now look at the $\bar{M}_7(t)(\partial_i^2\pi)^3 \sim M(H^6/c_s^6)\pi^3$ term though; comparing this contribution with the \bar{M}_1 term amounts to comparing M^3 with MH^2/c_s^2 . We see that for a very small speed of sound the \bar{M}_7 contribution may still be relevant. These examples justify our strategy of including all the terms in Eq. (13) compatible with $c_s \ll 1$ (we will make more comments on this point in Sec. 4).

Having written the action, we now proceed to elaborate about the solution to the equation of motion for the scalar degree of freedom π .

3. Solution to the equation of motion for the scalar degree of freedom

To solve for the equation of motion for the scalar degree of freedom π , we write the Lagrangian to second order in the perturbations. Note that in the equation below, as opposed to what was done in writing the third order action in Eq. (13), we include all possible terms, even the ones which are subleading and are therefore not expected to

give large non-Gaussianities.

$$\mathcal{L}_2 = a^3 \left[M_{\text{Pl}}^2 \dot{H} (\partial_\mu \pi)^2 + 2M_2^4 \dot{\pi}^2 - \bar{M}_1^3 H \left(3\dot{\pi}^2 - \frac{(\partial_i \pi)^2}{2a^2} \right) - \frac{\bar{M}_2^2}{2} (9H^2 \dot{\pi}^2 - 3H^2 \frac{(\partial_i \pi)^2}{a^2} + \frac{1}{a^4} (\partial_i^2 \pi)^2) - \frac{\bar{M}_3^2}{2} \left(3H^2 \dot{\pi}^2 - H^2 \frac{(\partial_i \pi)^2}{a^2} + \frac{1}{a^4} (\partial_j^2 \pi)^2 \right) \right]. \quad (14)$$

Following a common procedure, we have suppressed the time dependence in the M coefficients since we choose to work at leading order in the generalized slow roll approximation. After the usual change of variable, $\pi(\vec{k}, t(\tau)) = u(\vec{k}, \tau)/a(\tau)$, the equation of motion reads

$$u'' - \frac{2}{\tau^2} u + \alpha_0 k^2 u + \beta_0 k^4 \tau^2 u = 0, \quad (15)$$

where α_0, β_0 are time independent (again, at leading order in slow roll) dimensionless coefficients:

$$\alpha_0 = \frac{-M_{\text{Pl}}^2 \dot{H} - \bar{M}_1^3 H/2 - 3/2 \bar{M}_2^2 H^2 - \bar{M}_3^2 H^2/2}{-M_{\text{Pl}}^2 \dot{H} + 2M_2^4 - 3\bar{M}_1^3 H - 9/2 \bar{M}_2^2 H^2 - 3/2 \bar{M}_3^2 H^2},$$

$$\beta_0 = \frac{(\bar{M}_2^2 + \bar{M}_3^2) H^2}{2(-M_{\text{Pl}}^2 \dot{H} + 2M_2^4 - 3\bar{M}_1^3 H - 9/2 \bar{M}_2^2 H^2 - 3/2 \bar{M}_3^2 H^2)}. \quad (16)$$

Now, for the sake of simplification and in order to make sharper and more clear the correspondence between switching on the coefficients and recovering any specific inflationary models, we make the following choice: we take $\bar{M}_3^2 = -3\bar{M}_2^2$ and introduce $\bar{M}_0^2 = 2/3 \bar{M}_3^2$. As a consequence, the second order Lagrangian now reads:

$$\mathcal{L}_2 = a^3 \left(M_{\text{Pl}}^2 \dot{H} (\partial_\mu \pi)^2 + 2M_2^4 \dot{\pi}^2 - \bar{M}_1^3 H \left(3\dot{\pi}^2 - \frac{(\partial_i \pi)^2}{2a^2} \right) - \frac{\bar{M}_0^2}{2} \left(\frac{1}{a^4} (\partial_i^2 \pi)^2 \right) \right). \quad (17)$$

Since in the Lagrangian we lost one coefficient in going from $\bar{M}_{2,3}$ to \bar{M}_0 one might well count one less degree of freedom at our disposal in the calculations that follow. On the other hand, as one can easily check, the operators with the \bar{M}_2, \bar{M}_3 coefficients give rise to almost the same amplitude and shape for non-Gaussianities. Thus, the price to pay is not that high. The α_0 and β_0 parameters generalize the sound speed c_s^2 and the H^2/M^2 term (first introduced in Ref. [35]), respectively. Indeed, considering from now on Eq. (17) as our starting point, the complete expression for these parameters reads:

$$\alpha_0 = \frac{-M_{\text{Pl}}^2 \dot{H} - \bar{M}_1^3 H/2}{-M_{\text{Pl}}^2 \dot{H} + 2M_2^4 - 3\bar{M}_1^3 H}, \quad \beta_0 = \frac{\bar{M}_0^2 H^2}{2(-M_{\text{Pl}}^2 \dot{H} + 2M_2^4 - 3\bar{M}_1^3 H)}, \quad (18)$$

so that, for instance, one recovers the sound speed $1/c_s^2 = 1 - 2M_2^4/(M_{\text{Pl}}^2 \dot{H})$ for $\bar{M}_1 = 0$. The solution for standard inflation is recovered if $\beta_0 = \bar{M}_1 = 0$; the one for ghost inflation is obtained in the de Sitter limit if $\alpha_0 = 0 = \bar{M}_1$. Notice that, as evident from Eq. (18), there is the possibility of a negative value for α_0 , the generalized speed of sound. By looking at Eq. (15) one sees this would immediately result in a dispersion relation which, for $\alpha_0 k^2$ dominating over $\beta_0 k^4 \tau^2$, gives an exponential solution for the modes. As explained in [38], this fact does not necessarily exclude models with negative α_0 . In fact, as far as the $\beta_0 k^4 \tau^2$ term dominates soon enough in the UV before the

cutoff scale of the theory is reached, these models are still in principle acceptable as they eventually freeze at the Hubble scale. On the other hand, having an exponential growth, even for a limited energy window, can generate large non-Gaussianities which are ruled out by observations [38]. We plan to perform a detailed analysis of the issues associated with the α_0 -negative region of the parameters space in [39].

We can readily make some educated guesses on the behaviour of the wavefunction before solving the equation of motion. First of all, the typical oscillatory behaviour deep inside the horizon is to be expected: in this regime both $\alpha_0 k^2$ and $\beta_0 k^4 \tau^2$ cause wave-like behaviour on the wavefunction while the $(-2/\tau^2)$ contribution is negligible. This tells us the main contribution to correlation functions will be coming, as usual, from the horizon crossing region and the outside. Note here that, if $\beta_0 \neq 0$, the ‘ghost inflation’ term will eventually lead the oscillation if one goes deep enough inside the horizon. On the other hand, in the $\tau \rightarrow 0$ limit, the τ^{-2} term leads the dynamics and we recover the usual frozen modes. As done for the DBI case, it is convenient to introduce the notion of an effective horizon crossing, placing it where the oscillatory behaviour stops being dominant

$$\alpha_0 k^2 + \beta_0 k^4 \tau_*^2 \sim \frac{2}{\tau_*^2} \quad \Rightarrow \quad \tau_* = -\frac{2}{k\sqrt{\alpha_0 + \sqrt{\alpha_0^2 + 8\beta_0}}}. \quad (19)$$

For $\beta_0 = 0$ and $\alpha_0 \sim 1$ one recovers the usual $k^2 \tau_*^2 \sim 1$ horizon crossing.

Let us now be more quantitative. The solution to Eq. (15), being of second order, will come with two momentum-dependent integration constants. We have determined their values by requiring to obtain the known standard and ghost solutions in the corresponding limits. The general wavefunction reads

$$u(k, \tau) = \frac{1}{2^{1/4} \tau} i e^{\frac{1}{2} i \sqrt{\beta_0} k^2 \tau^2} \left[\text{HyperG} \left(-\frac{1}{4} - \frac{i\alpha_0}{4\sqrt{\beta_0}}, -\frac{1}{2}, -i\sqrt{\beta_0} k^2 \tau^2 \right) C_1(k) \right. \\ \left. + \text{LagL} \left(\frac{1}{4} + \frac{i\alpha_0}{4\sqrt{\beta_0}}, -\frac{3}{2}, -i\sqrt{\beta_0} k^2 \tau^2 \right) C_2(k) \right], \quad (20)$$

where HyperG is the confluent hypergeometric function and LagL stands for the generalized Laguerre polynomial. Upon fixing

$$C_1(k, \alpha_0, \beta_0) = \frac{(\alpha_0 + \sqrt{\beta_0})^{-3/4} \Gamma \left[\frac{5}{4} - \frac{i\alpha_0}{4\sqrt{\beta_0}} \right] k^{-3/2}}{2^{1/4} \sqrt{M_{\text{Pl}}^2 \epsilon H^2 + 2M_2^4 - 3\bar{M}_1^3 H} \Gamma \left[3/2 - \frac{\sqrt{\beta_0}}{4(i\alpha_0 + \sqrt{\beta_0})} \right]}, \quad C_2(k) = 0,$$

one can recover the normalized wavefunctions of standard inflation [36] and ghost inflation [35]. We can rewrite the solution as

$$\pi(k, \tau) = -\frac{H i e^{\frac{1}{2} i \sqrt{\beta_0} k^2 \tau^2} \Gamma \left[\frac{5}{4} - \frac{i\alpha_0}{4\sqrt{\beta_0}} \right] \text{HyperG} \left(-\frac{1}{4} - \frac{i\alpha_0}{4\sqrt{\beta_0}}, -\frac{1}{2}, -i\sqrt{\beta_0} k^2 \tau^2 \right)}{\sqrt{2(M_{\text{Pl}}^2 \epsilon H^2 + 2M_2^4 - 3\bar{M}_1^3 H)} (\alpha_0 + \sqrt{\beta_0})^{3/4} k^{3/2} \Gamma \left[\frac{5}{4} + \frac{\alpha_0}{4\alpha_0 - 4i\sqrt{\beta_0}} \right]}, \quad (21)$$

whose asymptotic expression for $\tau \rightarrow 0$ reads

$$\pi(k, \tau \simeq 0) \simeq \frac{iH\sqrt{\pi/8}}{\sqrt{M_{\text{Pl}}^2\epsilon H^2 + 2M_2^4 - 3\bar{M}_1^3 H} (\alpha_0 + \sqrt{\beta_0})^{3/4} k^{3/2} \Gamma\left[\frac{3}{2} - \frac{\sqrt{\beta_0}}{4(i\alpha_0 + \sqrt{\beta_0})}\right]}. \quad (22)$$

Note here the normalization factor in the denominator of Eq. (22):

$$\sqrt{M_{\text{Pl}}^2\epsilon H^2 + 2M_2^4 - 3\bar{M}_1^3 H} \equiv \mathcal{N}.$$

By looking at Eq. (13) one understands that this factor originates from canonically normalizing the kinetic term, which leads to $\pi_c = \mathcal{N}\pi$. Let us also mention that the expected behaviour of the wavefunction at horizon crossing we commented above, $\dot{\pi} \sim H\pi$ and $\nabla\pi \sim H/c_s \pi$, are now generalized to

$$\dot{\pi} \sim H\pi, \quad \nabla\pi \sim \frac{\sqrt{2}H}{\sqrt{\alpha_0 + \sqrt{\alpha_0^2 + 8\beta_0}}} \pi \quad (23)$$

It is then clear how one can in principle obtain high level of non-Gaussianity by means of terms in the Lagrangian with space derivatives (requiring $\alpha_0, \beta_0 \ll 1$ in the process) rather than time-like ones. A more detailed analysis of the general solution to the equation of motion and of the resulting power spectrum is to be found in [39].

4. Amplitude of the primordial non-Gaussianity

In this section we wish to perform a general analysis of the amplitude of the bispectra stemming from the general third-order interaction terms. The shape analysis will be done in the following section. In the calculations that follow we employ the so-called in-in formalism [40, 41, 42, 43]. To compute the amplitude of the non-Gaussianity, indicated by f_{NL} , we proceed as traditionally done in the literature and evaluate the three-point correlator in the so-called equilateral configuration where all momenta are taken to be equal: $k_1 = k_2 = k_3$. In other words one can write the bispectra of the gauge-invariant curvature perturbation ζ generated by each interaction term (I) as

$$\langle \zeta(\mathbf{k}_1)\zeta(\mathbf{k}_2)\zeta(\mathbf{k}_3) \rangle_I = (2\pi)^3 \delta^3(\mathbf{k}_1 + \mathbf{k}_2 + \mathbf{k}_3) B_I(k_1, k_2, k_3), \quad (24)$$

with an amplitude f_{NL}^I defined so that with all three-momenta equal $f_{\text{NL}}^I = (6/5)B_I(k, k, k)/P_\zeta(k)^2$, where $P_\zeta(k)$ is the power spectrum of the curvature perturbation. For large non-Gaussianities the linear relation $\zeta = -H\pi$ suffices for the bispectrum calculations since quadratic corrections give a negligible contributions. Notice also that the values of the integrals appearing in the in-in computations have been specified at horizon crossing and the contribution of the integral function at $\tau = -\infty$ has been put to zero mimicking the effect of the slight rotation of the τ -axis into the imaginary plane.

Given the broad number of possibilities, we choose to compute numerically the amplitude of the various bispectra identifying six benchmark points in the (α_0, β_0) plane

and numerically integrating the exact wavefunctions. Since one is interested in probing models with large non-Gaussianity, the values of (α_0, β_0) are taken much smaller than unity as described in the following Table:

Benchmarks	1	2	3	4	5	6
α_0	10^{-2}	0	$0.5 \cdot 10^{-2}$	$2 \cdot 10^{-7}$	10^{-4}	10^{-6}
β_0	0	$0.5 \cdot 10^{-4}$	$0.25 \cdot 10^{-4}$	$5 \cdot 10^{-5}$	0	0

Upon using Eq. (18) one can check that the first four benchmark points correspond to the same choice of the effective horizon. This choice has been made to suitably perform a comparison between the various cases and in particular against the values of f_{NL} of purely DBI and Ghost models which correspond to benchmarks 1 and 2. The last two configurations (which are pure DBI) probe the space of extremely small α_0 and, in interactions with at least two space derivatives, are expected to give a larger amplitude than the first four points, at least if the interaction terms are regulated by unconstrained masses. To get the feeling for the figures involved, if we restrict ourselves to the case of theories for which α_0 reduces to the usual sound speed c_s^2 , typical values of c_s are between 10^{-3} and 10^{-2} . Note also that the definition of c_s varies according to which operators are switched on in the action (one can well be in the de Sitter limit where the only spatial quadratic term has four derivatives; this leads to a different c_s , see also [38]). Therefore we choose to specify all the amplitudes as a function of the various M and \bar{M} masses.

It is convenient at this stage to clearly point out which M coefficients in Eq. (13) are free and underline the relations among the constrained ones. From Eq. (18) one can see that, despite fixing α_0 , as we did in the Table, there is still the freedom to pick any reasonable value for either M_2^4 or \bar{M}_1^3 . Similarly, fixing β_0 does not completely specify \bar{M}_0 . In other words, both \bar{M}_1^3 and \bar{M}_0^2 are constrained by our choice of the (α_0, β_0) parameters; all the other coefficients are unconstrained. As the M 's are expected to set the energy scale of the various underlying theories, they should be larger than the Hubble rate H , and can go up to M_{Pl} . As elucidated in Ref. [24] though, for the action (13) to be as general as possible, one might want to require the M 's to be smaller than the Planck mass. That said, some useful inequalities that the mass coefficients must respect can now be reminded. Due to the fact we are working in the decoupling regime, we must require $M_2^4 < M_{\text{Pl}}^2 H^2$. Also, the fact that we are probing the $(\alpha_0, \beta_0) \ll 1$ space, imposes bounds on some masses. Consider the parameter α_0 in Eq. (18). There are two ways this coefficient can be much smaller than unity. The first and perhaps most natural way, is to ask $M_2^4 \gg \text{Max}(-M_{\text{Pl}}^2 \dot{H}, -\bar{M}_1^3 H)$ which, due to decoupling inequalities on M_2 puts a bound on \bar{M}_1 , $\bar{M}_1^3 \ll M_{\text{Pl}}^2 H$. The other possibility requires a partial cancellation in the numerator of α_0 , $-M_{\text{Pl}}^2 \dot{H} \sim \bar{M}_1^3 H/2$ which is certainly possible but it implies we are neither in the DBI, nor in the ghost regime, both of which have $\bar{M}_1 = 0$. Looking at β_0 we see it is enough to require $M_0^2 H^2 \ll M_2^4$ or $M_0^2 H^2 \ll -\bar{M}_1^3 H$ and again, the first condition seems more natural. Let us stress here that, upon requiring the masses

to be all of the same order, M , and using that $H/M \ll 1$ in the effective theory, one can easily obtain small α_0, β_0 coefficient. However, when employing a single mass scale M in the whole Lagrangian, working with tiny values for α_0 and β_0 would put a bound on M and necessarily influence the magnitude of all the interaction terms. In our analysis we let the M, \bar{M} 's coefficients be not all of the same order (with some important caveats upon which we expand at the end of this section).

Below we present the results for each interaction term. All the amplitudes can be written as a dimensionless coefficient, γ_n , times an (α_0, β_0) -dependent numerical coefficient. The terms described in the first subsection are interactions that have already been discussed in the literature. The novelty here is represented by the fact we are able to study also interpolating configurations through the third and fourth benchmark points. In the second subsection we report on the amplitudes of the contributions from some curvature-generated terms that have never been discussed in the literature.

4.1. Amplitudes from DBI-like interactions and first two curvature-generated terms

The amplitudes from DBI-like interactions and first two curvature-generated terms are the following:

- $\mathcal{O}_1 = -2M_2^4 \dot{\pi}(\partial_i \pi)^2 / a^2$

benchmarks	1	2	3	4	5	6
$f_{\text{NL}}^{M_2}$	$10^2 \gamma_1$	$8 \cdot 10^1 \gamma_1$	$6 \cdot 10^1 \gamma_1$	$4 \cdot 10^1 \gamma_1$	$10^4 \gamma_1$	$10^6 \gamma_1$

where

$$\gamma_1 = \frac{M_2^4}{2M_2^4 + M_{\text{Pl}}^2 \epsilon H^2 - 3\bar{M}_1^3 H}. \quad (25)$$

We see the parameter γ_1 can in principle be of order unity. Indeed, if one assumes M_2^4 is the largest term in the denominator (in DBI this would correspond to a very small speed of sound), γ_1 is roughly $1/2$.

- $\mathcal{O}_2 = -4/3 M_3^4 \dot{\pi}^3$

benchmarks	1	2	3	4	5	6
$f_{\text{NL}}^{M_3}$	$1/2 \gamma_2$	$10^{-2} \gamma_2$	$5 \cdot 10^{-2} \gamma_2$	$10^{-2} \gamma_2$	$1/2 \gamma_2$	$1/2 \gamma_2$

where

$$\gamma_2 = \frac{M_3^4}{2M_2^4 + M_{\text{Pl}}^2 \epsilon H^2 - 3\bar{M}_1^3 H}. \quad (26)$$

The parameter γ_2 can be even larger than unity if, for instance, M_3 is larger than M_2 . We can see, already at this stage, the effect of small values of α_0 and β_0 at work: the numerical factor of a spatial derivative-free interaction is much smaller than that of a third order term like the M_2 one calculated above which has two spatial derivatives.

- $\mathcal{O}_3 = -1/2 \bar{M}_1^3 (\partial_i \pi)^2 \partial_j^2 \pi / a^4$

benchmarks	1	2	3	4	5	6
$f_{\text{NL}}^{M_1}$	$10^5 \gamma_3$	$10^3 \gamma_3$	$4 \cdot 10^4 \gamma_3$	$1.5 \cdot 10^3 \gamma_3$	$10^9 \gamma_3$	$10^{13} \gamma_3$

Due to the fact that \bar{M}_1^3 is a constrained parameter we find that the amplitude equals an (α_0, β_0) -dependent number times the parameter

$$\gamma_3 = \frac{-M_{\text{Pl}}^2 \epsilon H^2 (1 - \alpha_0) + 2\alpha_0 M_2^4}{M_{\text{Pl}}^2 \epsilon H^2 + 2M_2^4 - 3\bar{M}_1^3 H}. \quad (27)$$

One should substitute the various values of α_0 in the Table in the γ_3 expression given above. Barring cancellation between different mass terms, γ_3 is generally smaller than one and can be as small as α_0 itself.

- $\mathcal{O}_4 = -1/2 \bar{M}_0^2 / 4 (5H(\partial_i^2 \pi)(\partial_j \pi)^2 + 4\dot{\pi} \partial_i^2 \partial_j \pi \partial_j \pi) / a^4$

benchmarks	1	2	3	4	5	6
$f_{\text{NL}}^{M_0}$	$3 \cdot 10^5 \gamma_4$	$10^5 \gamma_4$	$1.3 \cdot 10^4 \gamma_4$	$10^5 \gamma_4$	$3 \cdot 10^9 \gamma_4$	$3 \cdot 10^{13} \gamma_4$

with

$$\gamma_4 = (\bar{M}_0^2 H^2) / (M_{\text{Pl}}^2 \epsilon H^2 + 2M_2^4 - 3\bar{M}_1^3 H). \quad (28)$$

We see that large numerical coefficients appear in such a case, nevertheless $\gamma_4 = \beta_0 \ll 1$.

4.2. Amplitudes from curvature-generated novel interaction terms

We come to the curvature-generated interaction terms that generate novel bispectra. Their amplitudes are given by

- $\mathcal{O}_5 = -2/3 \bar{M}_4^3 \dot{\pi}^2 \partial_i^2 \pi / a^2$

benchmarks	1	2	3	4	5	6
$f_{\text{NL}}^{M_4}$	$7 \cdot 10^2 \gamma_5$	$10^2 \gamma_5$	$2 \cdot 10^2 \gamma_5$	$10^2 \gamma_5$	$7 \cdot 10^4 \gamma_5$	$7 \cdot 10^6 \gamma_5$

where

$$\gamma_5 = (\bar{M}_4^3 H) / (M_{\text{Pl}}^2 \epsilon H^2 + 2M_2^4 - 3\bar{M}_1^3 H). \quad (29)$$

The coefficient γ_5 can be larger than unity. Barring cancellations in the denominator, a $\gamma_5 \gg 1$ larger than unity imposes $\bar{M}_4 \gg M_2, \bar{M}_1$.

- $\mathcal{O}_6 = 1/3 \bar{M}_5^2 \dot{\pi} (\partial_i^2 \pi)^2 / a^4$

benchmarks	1	2	3	4	5	6
$f_{\text{NL}}^{M_5}$	$5 \cdot 10^4 \gamma_6$	$1.6 \cdot 10^4 \gamma_6$	$2 \cdot 10^4 \gamma_6$	$1.6 \cdot 10^4 \gamma_6$	$4 \cdot 10^8 \gamma_6$	$4 \cdot 10^{12} \gamma_6$

where

$$\gamma_6 = (\bar{M}_5^2 H^2) / (M_{\text{Pl}}^2 \epsilon H^2 + 2M_2^4 - 3\bar{M}_1^3 H). \quad (30)$$

To get $\gamma_6 \gg 1$, one needs to impose a less natural condition $\bar{M}_5^2 H^2 \gg M_2^4, \bar{M}_1^3 H$.

- $\mathcal{O}_7 = 1/3 \bar{M}_6^2 \dot{\pi} (\partial_{ij} \pi)^2 / a^4$

benchmarks	1	2	3	4	5	6
$f_{\text{NL}}^{M_6}$	$10^4 \gamma_7$	$4 \cdot 10^3 \gamma_7$	$5 \cdot 10^3 \gamma_7$	$4 \cdot 10^3 \gamma_7$	$10^8 \gamma_7$	$10^{12} \gamma_7$

where

$$\gamma_7 = (\bar{M}_6^2 H^2) / (M_{\text{Pl}}^2 \epsilon H^2 + 2M_2^4 - 3\bar{M}_1^3 H). \quad (31)$$

The same consideration as for the case of \bar{M}_5 apply here. Note again that the numerical values, especially in the fifth and sixth benchmark points tend to be much larger for the M coefficients with the most spatial derivatives, thus confirming our expectations.

- $\mathcal{O}_8 = -1/6 \bar{M}_7 (\partial_i^2 \pi)^3 / a^6$

benchmarks	1	2	3	4	5	6
$f_{\text{NL}}^{M_7}$	$8 \cdot 10^6 \gamma_8$	$2.6 \cdot 10^6 \gamma_8$	$3.5 \cdot 10^6 \gamma_8$	$2.6 \cdot 10^6 \gamma_8$	$8 \cdot 10^{12} \gamma_8$	$8 \cdot 10^{18} \gamma_8$

with

$$\gamma_8 = (\bar{M}_7 H^3) / (M_{\text{Pl}}^2 \epsilon H^2 + 2M_2^4 - 3\bar{M}_1^3 H). \quad (32)$$

Notice that in this case, and in the following ones, the γ coefficients are naturally expected to be smaller than unity. For this interaction, as well as the two following ones, the numerical factor coming from the integration can be quite large, especially in the fifth and sixth benchmark points. This is clearly due to the six space derivatives that characterize these interactions.

- $\mathcal{O}_9 = -1/6 \bar{M}_8 \partial_i^2 \pi (\partial_{jk} \pi)^2 / a^6$

benchmarks	1	2	3	4	5	6
$f_{\text{NL}}^{M_8}$	$2 \cdot 10^6 \gamma_9$	$6 \cdot 10^5 \gamma_9$	$8 \cdot 10^5 \gamma_9$	$6 \cdot 10^5 \gamma_9$	$2 \cdot 10^{12} \gamma_9$	$2 \cdot 10^{18} \gamma_9$

with

$$\gamma_9 = (\bar{M}_8 H^3) / (M_{\text{Pl}}^2 \epsilon H^2 + 2M_2^4 - 3\bar{M}_1^3 H). \quad (33)$$

Let us stress that one could guess the amplitude of $\bar{M}_{8,9}$ terms by simply looking at the results obtained for the interaction term tuned by \bar{M}_7 because, although these terms might produce a different shape for non-Gaussianities, they have essentially the same structure as far as the integration is concerned.

- $\mathcal{O}_{10} = -1/6 \bar{M}_9 \partial_{ij} \pi \partial_{jk} \pi \partial_{ki} \pi / a^6$

benchmarks	1	2	3	4	5	6
$f_{\text{NL}}^{M_9}$	$10^6 \gamma_{10}$	$3 \cdot 10^5 \gamma_{10}$	$4 \cdot 10^5 \gamma_{10}$	$3 \cdot 10^5 \gamma_{10}$	$10^{12} \gamma_{10}$	$10^{18} \gamma_{10}$

where

$$\gamma_{10} = (\bar{M}_9 H^3) / (M_{\text{Pl}}^2 \epsilon H^2 + 2M_2^4 - 3\bar{M}_1^3 H). \quad (34)$$

One could again just read off the maximum value from $f_{\text{NL}}^{\bar{M}_7}$, they differ by just a factor 1/8.

4.3. Some general considerations on the amplitudes of non-Gaussianities

It might be worth now to pause and comment on our findings in relation to earlier results in the literature. As we have stressed, the non-Gaussianity generated from operators proportional to the \bar{M} 's masses arises from curvature terms that are often neglected. From general considerations, one expects that the curvature terms, especially the ones coming from δK^3 -type of contributions, can often be neglected. This is not generically true though. The general structure of the amplitudes we have found for the bispectra can be schematically written as

$$\mathcal{A}_n \sim \frac{1}{\left(\sqrt{\alpha_0 + \sqrt{\alpha_0^2 + 8\beta_0}}\right)^q} \frac{\tilde{M}_n^{4-q} H^q}{2M_2^4 + M_{\text{Pl}}^2 \epsilon H^2 - 3\bar{M}_1^3 H}, \quad (35)$$

where \tilde{M}_n stands for a generic mass coefficient of the type M, \bar{M} .

If $\tilde{M}_n \gg H / (\alpha_0 + (\alpha_0^2 + 8\beta_0)^{1/2})^{1/2}$, and the masses are all of the same order, then it is natural to expect the \tilde{M}_n with the largest exponent to dominate. In this case the dominant terms are those associated with M_2 and M_3 , corresponding to DBI inflation. Furthermore, we may also recall that large masses appear also in the definition of α_0, β_0 and, at least in DBI, a large M_2 is needed to have a small speed of sound.

On the other hand, one can employ the freedom for all the M 's not to be of the same order in magnitude. The \widetilde{M}_n 's have a natural upper bound that must be smaller than the Planck mass and in the general theory with both DBI and ghost (and more in general curvature terms) operators switched on, one can allow for a very small speed of sound without assuming much on the unconstrained masses. In such cases, the generalized sound speed can be so small that $H/(\alpha_0 + (\alpha_0^2 + 8\beta_0)^{1/2})^{1/2}$ is actually larger than \widetilde{M} . Consequently, the amplitudes of the masses with a smaller exponent, typically the barred \bar{M} 's, are not negligible any longer. We conclude that large non-Gaussianities may be induced by theories parametrized by suitable values of the \bar{M} masses.

It is important at this stage to offer some additional comments on the general structure of the Lagrangian and of the resulting amplitudes. As clear from Eq. (23), each space derivative acting on the scalar π can be schematically written in Fourier space as a term $H\pi$ divided by a number which is much smaller than unity in the cases of interest. Now, it is clear from dimensional analysis that other terms in the action, specifically the ones with less derivatives, will have their own $H/(\alpha_0 + (\alpha_0^2 + 8\beta_0)^{1/2})^{1/2}$ factors coming from derivatives but, most importantly, will also need some generic M factor to make the action properly dimensionless. This is exactly what happens in our theory (see Eq. (13)) as well: the exponent of \bar{M}_1 is bigger than the one of \bar{M}_2 and so on. We have employed in the analysis of the amplitudes some freedom on these \bar{M}_n parameters to show that even terms with higher spatial derivatives can give non negligible contributions to the amplitude. Of course, if one wants to have a reliable effective theory the \bar{M}_n coefficients must eventually prevail over $H/(\alpha_0 + (\alpha_0^2 + 8\beta_0)^{1/2})^{1/2}$ (in a Lorentz invariant theory it would suffice to ask for $\bar{M}_n \gg H$, here we need more) so that it makes sense to consider higher derivatives up to some given finite order, but not further.

5. The shapes of non-Gaussianities

In this section we wish to analyze the shapes of the bispectra generated by the various operators analyzed above. In calculating the amplitudes on the bispectra in the previous section we have chosen to perform, albeit numerically, calculations with the exact wavefunctions. We decided to counterbalance the loss of information in not having α_0, β_0 explicit in the result by running the same procedure for six different benchmark values of the parameters. In analysing the shapes we do not enjoy the possibility to use the exact wavefunction any longer as we must approximate the wavefunctions inside the conformal time τ integral(s) calculated as prescribed by the in-in formalism. Of course, exact results are always available when the classical solution reduces to the usual, Hankel function $H_{(3/2)}(\tau)$. In computing terms like

$$\int_{-\infty}^{\tau} d\tilde{\tau} \frac{1}{H^4 \tilde{\tau}^4} [\dot{\pi}_{k1}(t(\tilde{\tau})) \dot{\pi}_{k2}(t(\tilde{\tau})) \dot{\pi}_{k3}(t(\tilde{\tau}))], \quad (36)$$

we have chosen to expand in series each k -mode inside the integrand within a region that starts from slightly inside its effective horizon (setting to zero the function in the rest of the interval). This enables us to keep both, parameters and external momenta, arbitrary. This approximation is justified by the fact that, due to the oscillatory behaviour of the wavefunctions^{||}, the main contribution to the integral comes only from the region where all the wavefunctions are not oscillating anymore (to be safe, we actually choose to include the region where the k -mode with the latest effective horizon is still within its horizon). Furthermore, it is reasonable to assume that, even if some non-negligible contribution is being left over because of this approximation procedure, it might have a systematic effect on all k -modes and would therefore not change the shapes of the bispectrum of perturbations. This procedure has been calibrated with the calculations of Ref. [11] which were performed exactly: we are able to reproduce the very same shapes for the bispectrum.

Following the scheme used for the amplitudes, we now report below the shape of non-Gaussianity for each interaction term. Within a single interaction term, we consider four configurations in the (α_0, β_0) -plane. We preliminary found that the shape are not particularly sensible to their absolute values. This is expected as these coefficients, being the same for each k -mode, enter mainly in the amplitudes, not in the shapes. Therefore, we limited our attention to the α_0/β_0 ratios. We probed the following cases: $\alpha_0 \neq 0, \beta_0 \simeq 0$ (DBI); $\alpha_0 \simeq 0, \beta_0 \neq 0$ (ghost); $\alpha_0 \neq 0 \neq \beta_0$ (with the solution interpolating between DBI and ghost inflation and α_0 playing the dominating role in determining where is the effective horizon, we call this configuration *A*) and $\alpha_0 \neq 0 \neq \beta_0$ (with the effect of β_0 leading in the expression for the horizon, we call this configuration *B*).

Let us briefly add some general preliminary comments. We need to point out that when we use the name DBI might generate some confusion. Indeed, we use it also to describe shapes due to interaction terms coming from curvature perturbations, such as $\bar{M}_{1,2,3,\dots}$. What we mean here is that we can employ in the integrations the usual wavefunction $\pi_k \propto e^{-i\sqrt{\alpha_0}k\tau}(1 + i\sqrt{\alpha_0}k\tau)$ without resorting to any approximation. This wavefunction can be used as far as it is the solution to the equation of motion. This is a condition concerning only second order perturbations: we need only require $\beta_0 = 0 \Leftrightarrow 0 = M_0$ to employ it. We can, at the same time, have extrinsic curvature-driven interaction terms, the \bar{M} 's, and yet find exact results. The shapes corresponding to what we denominate DBI configuration have been thoroughly investigated in a number of papers [8], but what has been generally left out is the contribution coming from the extrinsic curvature terms: it is indeed possible to have the usual Hankel, $H_{3/2}(\tau)$, wavefunction as a solution to the classical equations and, at the same time,

^{||} Of course, an oscillatory behaviour is not, by itself, enough to provide a cancellation all over the -inside the horizon- region. Indeed in some cases for $\tau \rightarrow -\infty$ the amplitude of the wavefunctions increases and one certainly does not expect this to give zero contribution. On the other hand, much like in the simplest single field slow-roll calculations, one is expected to slightly rotate τ to the imaginary plane to match the vacuum thus basically putting to zero the contribution at $-\infty$.

switch on curvature operators like $\bar{M}_{4,5,6,7,8,9}$. All the shapes obtained in the DBI configuration are generated through exact analytical methods. We will call them as “exact-DBI configurations”. Should we find, as we will, a shape which is not equilateral in the first configuration, that shape suffers none of any possible limitations the approximated method might introduce. The ghost configuration has been analyzed in depth in many articles, among which [33, 38], and again, not all the terms coming from extrinsic curvature have been taken into account. It is important to note though that in [23, 33, 38] the M coefficients multiplying curvature terms have all been chosen of the same order thus resulting in only a couple of leading curvature (they correspond to the \bar{M}_1, \bar{M}_0 contributions). Finally, the shapes in configuration A, B have never been analyzed before.

The shapes reported below have been obtained by employing the shape function $B(1, x_2, x_3)$, where $x_i = k_i/k_1$, which possesses the same $k_{1,2,3}$ -dependence as the three point function. What is plotted exactly is $x_2^2 x_3^2 B(1, x_2, x_3)/B(1, 1, 1)$ in the region satisfying $x_2 \geq x_3 \geq 1 - x_2$ [10]. Let us remind the reader that a shape is called local when it peaks for a small value of, say, x_2 , with $x_1 = x_3 = 1$; equilateral when it peaks in the equilateral configuration $x_1 = 1, x_2 = 1 = x_3$ and is called flat for squashed triangles with $1 = x_2 + x_3$. In particular, we find, as detailed below, that some novel curvature-generated terms produce a flat bispectrum which specifically peaks for $x_2 = x_3 = 1/2$. In presenting the shapes we follow the same order and organization we employed for the amplitudes:

5.1. Shapes from DBI-like interactions and first two curvature-generated terms.

- $\mathcal{O}_1 = -2M_2^4 \dot{\pi}(\partial_i \pi)^2/a^2$

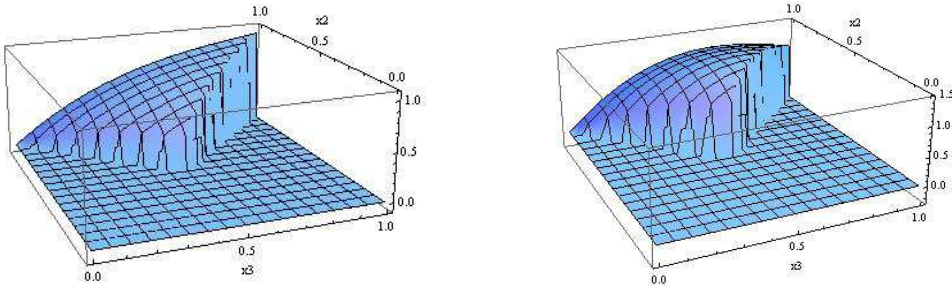

Figure 1. DBI configuration on the left, obtained using exact methods; the approximated ghost shape on the right.

Note that, although more or less sharply, all the four plots are peaked in the equilateral configuration.

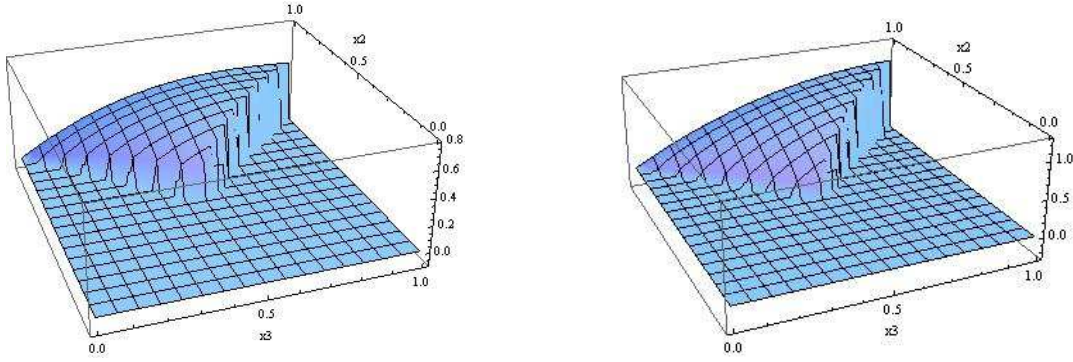

Figure 2. *A* configuration on the left, *B* configuration on the right.

- $\mathcal{O}_2 = 4/3 M_3^4 \dot{\pi}^3$

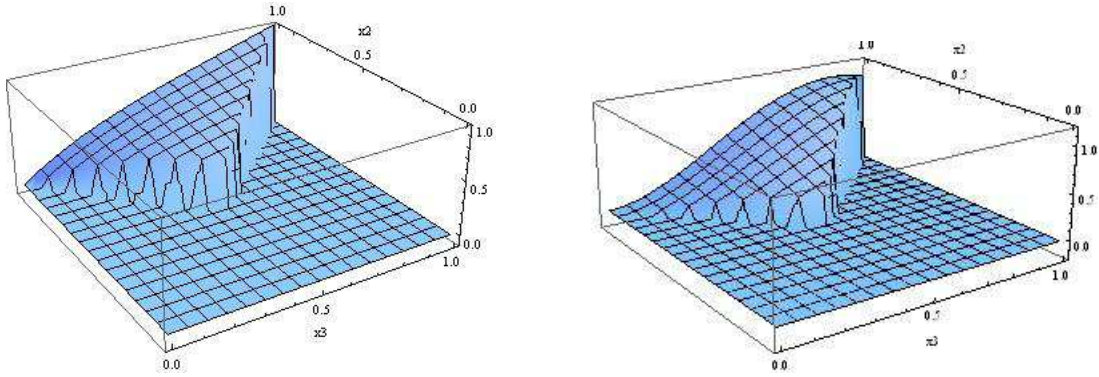

Figure 3. exact DBI configuration on the left; approximated ghost shape on the right.

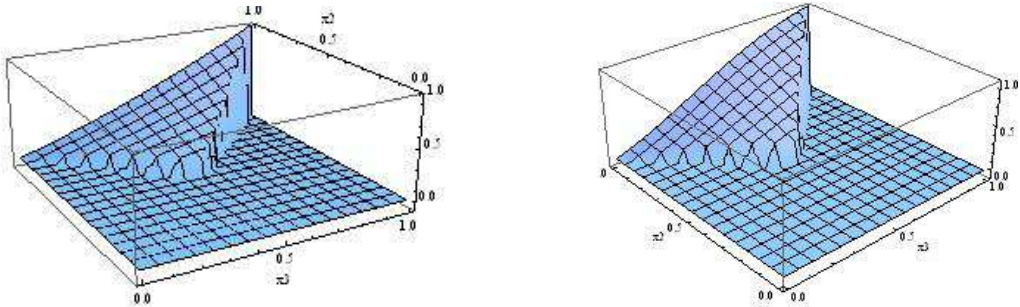

Figure 4. *A* on the left, *B* configuration on the right for the M_3 -driven interaction term.

We obtain equilateral shapes in all four cases. It is somewhat expected that the general, interpolating solution employed in configurations *A* and *B*, will give qualitatively the same plot, we have verified it in these first two rounds of shapes.

- $\mathcal{O}_3 = -1/2 \bar{M}_1^3 (\partial_i \pi)^2 \partial_j^2 \pi / a^4$

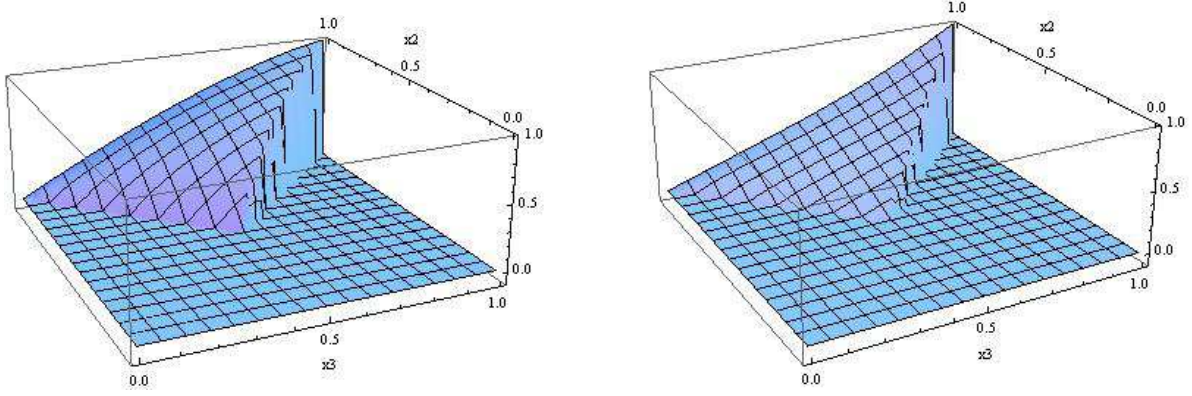

Figure 5. exact DBI configuration on the left; approximated ghost shape on the right.

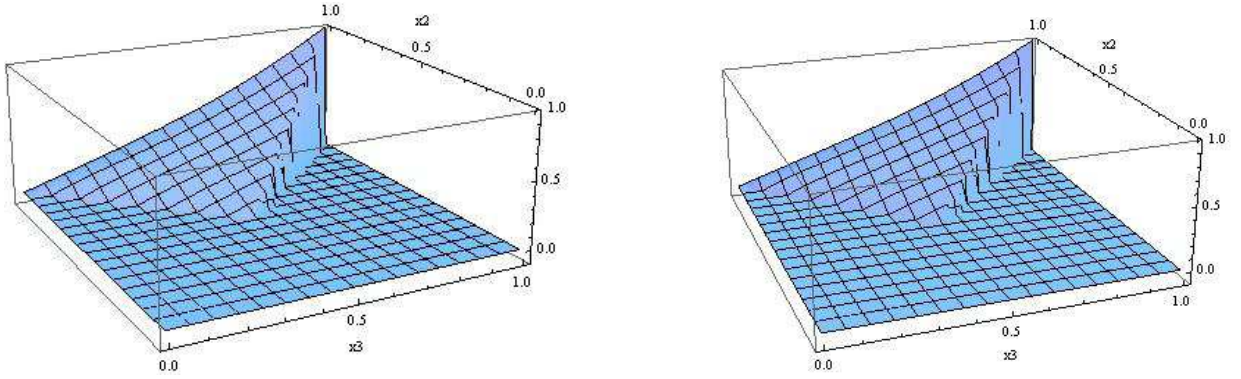

Figure 6. *A* on the left, *B* configuration on the right for the \bar{M}_1 -driven interaction term.

Also the bispectrum generated by this interaction term has an equilateral shape; the last two plots show, employing the general wavefunction, that also the interpolating models produce an equilateral shape.

- $\mathcal{O}_4 = -1/2 \bar{M}_0^2 / 4 (5H(\partial_i^2 \pi)(\partial_j \pi)^2 + 4\dot{\pi} \partial_i^2 \partial_j \pi \partial_j \pi) / a^4$

The various bispectra peak in the equilateral configuration.

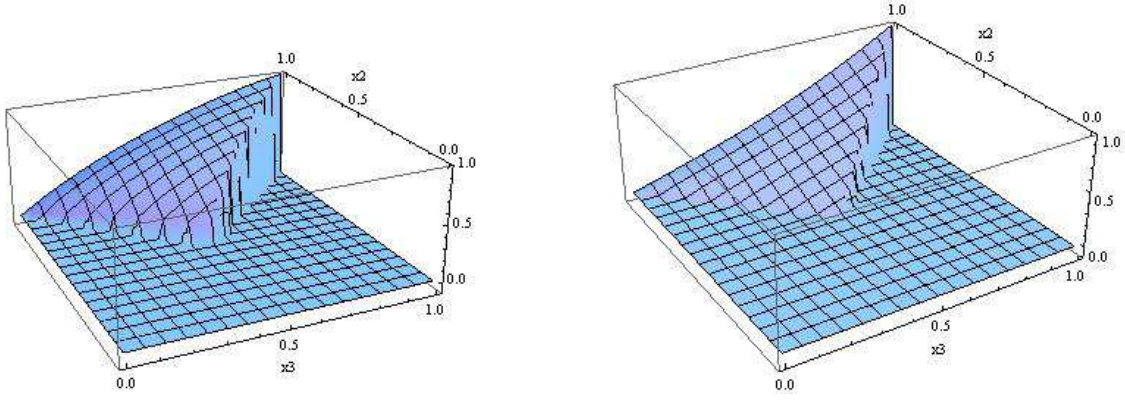

Figure 7. exact DBI configuration on the left; approx. ghost shape on the right.

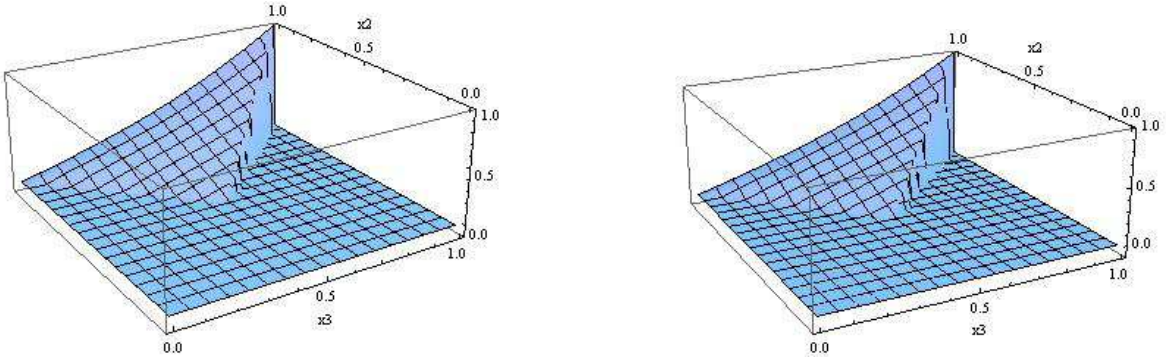

Figure 8. A on the left, B configuration on the right for the \bar{M}_0 interaction term.

5.2. Shapes from curvature-generated novel interaction terms.

- $\mathcal{O}_5 = -2/3 \bar{M}_4^3 \dot{\pi}^2 \partial_i^2 \pi / a^2$

With the term tuned by \bar{M}_4 we start including in our description the contributions that have so far been neglected in the literature.

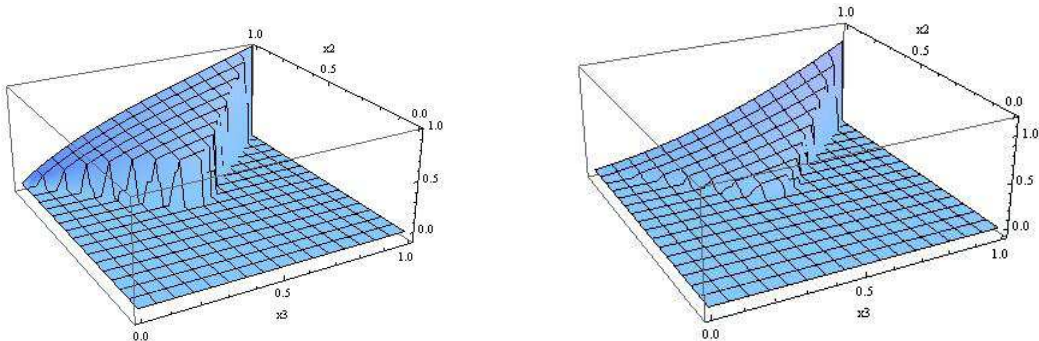

Figure 9. exact DBI configuration on the left; approximated ghost shape on the right.

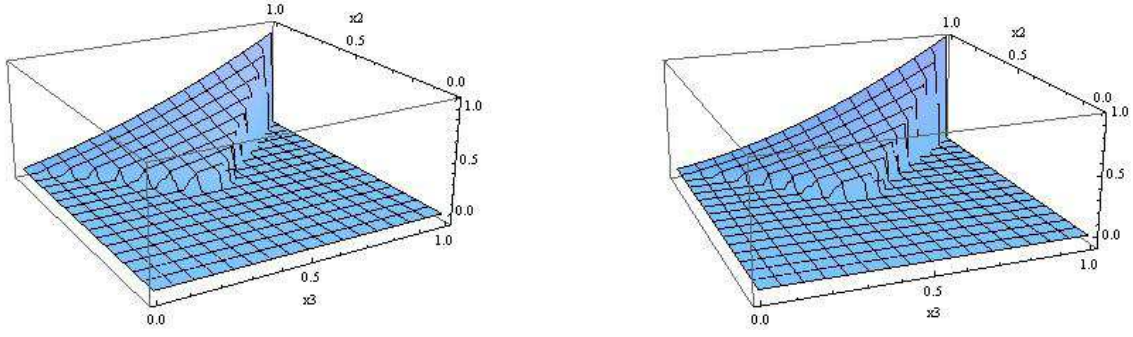

Figure 10. *A* on the left, *B* configuration on the right for the \bar{M}_4 -driven interaction term.

Equilateral shapes for all configurations are obtained.

- $\mathcal{O}_6 = 1/3 \bar{M}_5^2 \dot{\pi} (\partial_i^2 \pi)^2 / a^4$

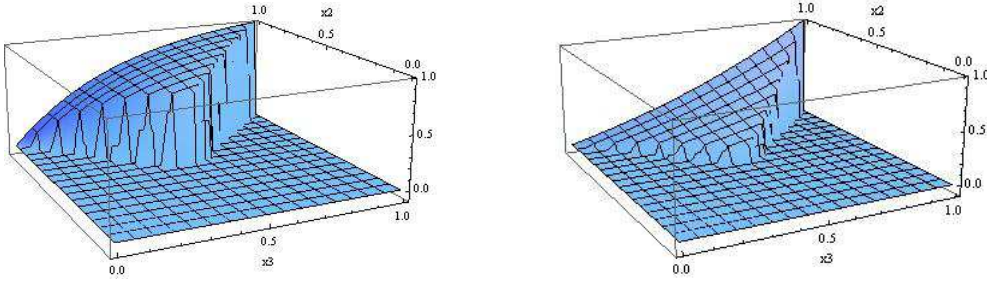

Figure 11. exact DBI configuration on the left; approximated ghost shape on the right.

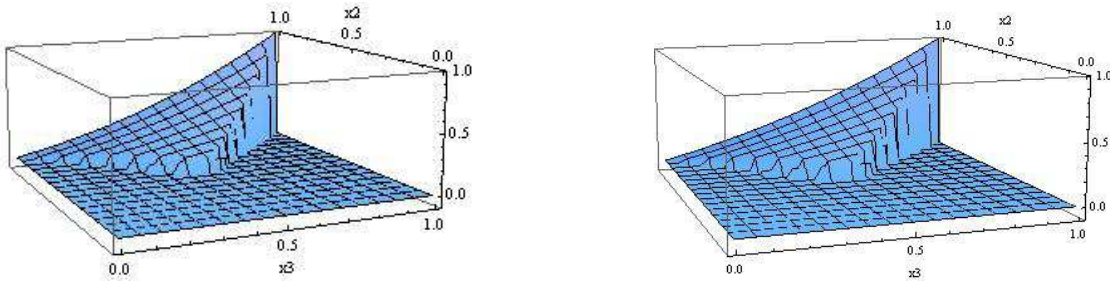

Figure 12. *A* on the left, *B* configuration on the right for the \bar{M}_5 -driven interaction term.

Again, all the four bispectra peak in the equilateral configuration.

- $\mathcal{O}_7 = 1/3 \bar{M}_6^2 \dot{\pi} (\partial_{ij} \pi)^2 / a^4$

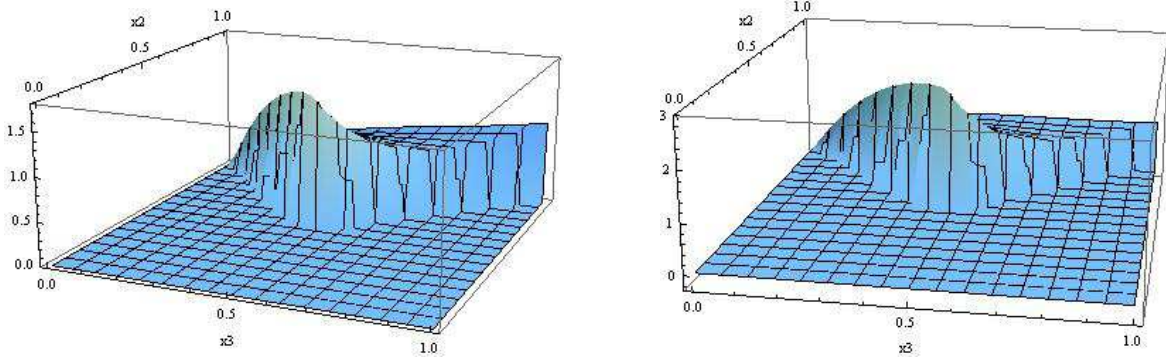

Figure 13. exact DBI configuration on the left; approximated ghost shape on the right.

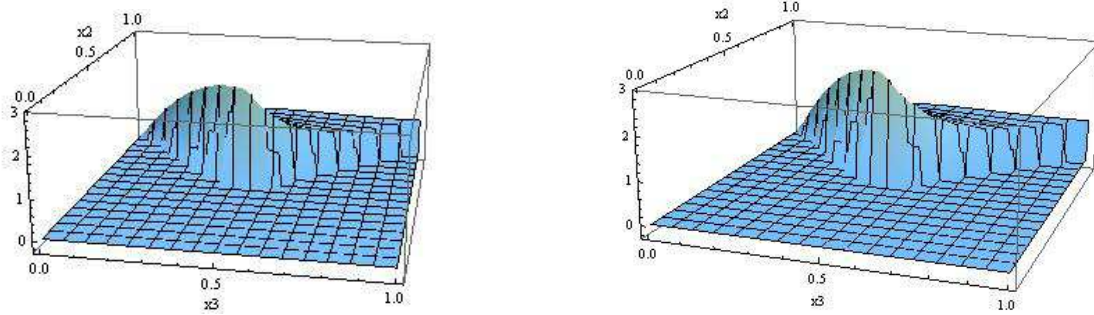

Figure 14. *A* on the left, *B* configuration on the right for the \bar{M}_6 -driven interaction term.

This is one of the interesting novel curvature-generated terms that give rise to a flat shape (precisely the plot peaks at $k_1 = 1, k_2 \sim 1/2 \sim k_3$). Note that for a very similar interaction, namely the one generated by \mathcal{O}_6 , we saw an equilateral plot. Here, derivatives combine to provide a different k -dependent factor outside the integral. Writing in Fourier space the interaction term \mathcal{O}_6 we obtain something proportional to $k_2^2 k_3^2$, while here we obtain something like $(\vec{k}_2 \cdot \vec{k}_3)^2$.

- $\mathcal{O}_8 = -1/6 \bar{M}_7 (\partial_i^2 \pi)^3 / a^6$

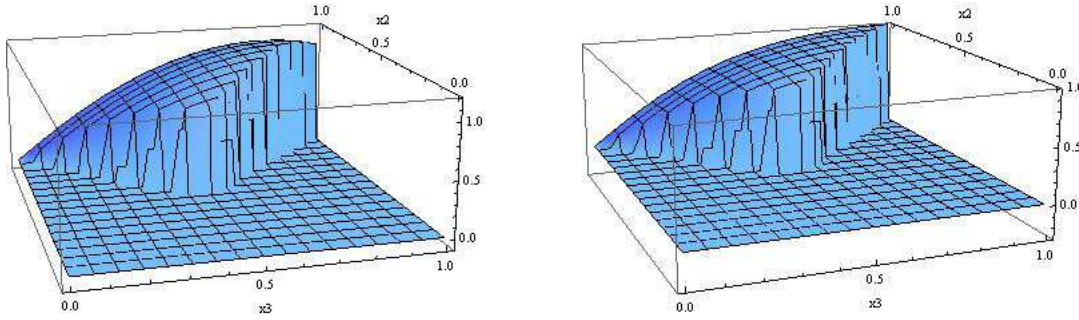

Figure 15. exact DBI configuration on the left; approximated ghost shape on the right.

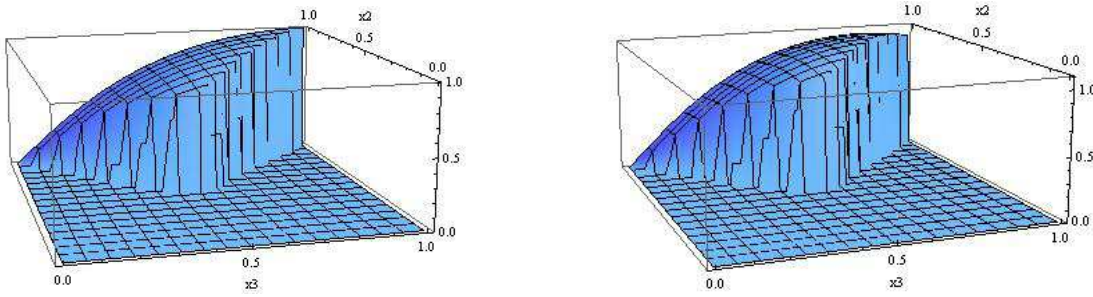

Figure 16. *A* on the left, *B* configuration on the right for the \bar{M}_7 -driven interaction term.

All shapes peak in the equilateral configuration.

- $\mathcal{O}_9 = -1/6 \bar{M}_8 \partial_i^2 \pi (\partial_{jk} \pi)^2 / a^6$

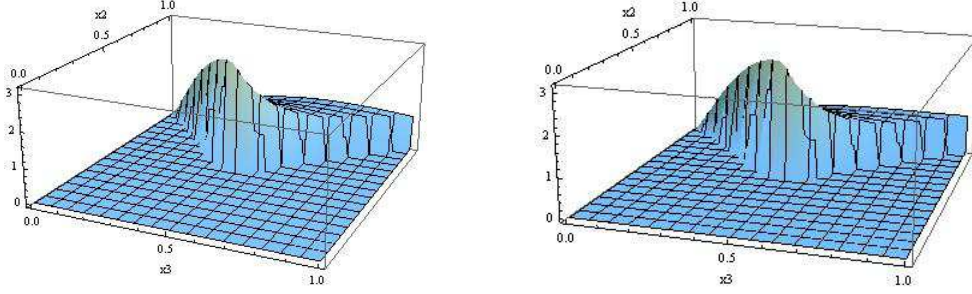

Figure 17. exact DBI configuration on the left; approximated ghost shape on the right.

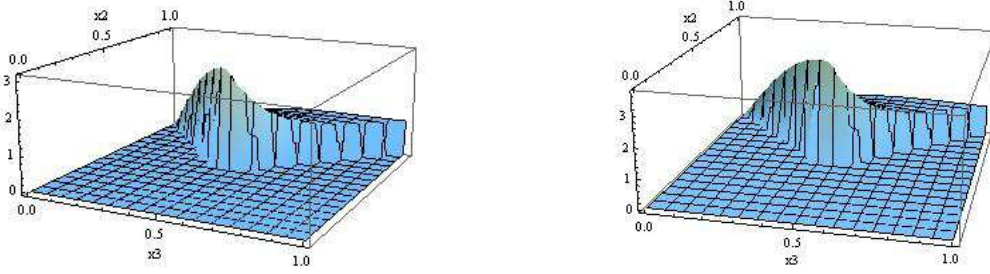

Figure 18. *A* on the left, *B* configuration on the right for the \bar{M}_8 -driven interaction term

This is a second interaction term that produces, just as for \mathcal{O}_7 , a flat shape for the bispectra. Comparing it in Fourier space with our findings for \mathcal{O}_8 , one can see that it is due to the way the spatial derivatives are combined. As shown in Figs. 19 and 20, also \mathcal{O}_{10} gives rise to flat-shape bispectrum. We can see that the interactions \mathcal{O}_8 , \mathcal{O}_9 and \mathcal{O}_{10} have the same structure as far as the integral is concerned; on the other hand their k -dependence goes like $k_1^2 k_2^2 k_3^2$, $k_1^2 (\vec{k}_2 \cdot \vec{k}_3)^2 + \text{perm}$ and $(\vec{k}_1 \cdot \vec{k}_2)(\vec{k}_2 \cdot \vec{k}_3)(\vec{k}_3 \cdot \vec{k}_1)$, respectively. The last two produce a flat shape.

- $\mathcal{O}_{10} = -1/6 \bar{M}_9 \partial_{ij} \pi \partial_{jk} \pi \partial_{ki} \pi / a^6$

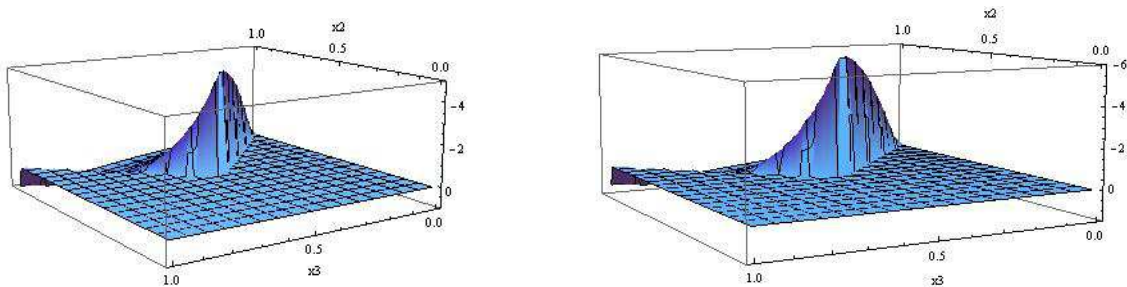

Figure 19. exact DBI configuration on the left; approximated ghost shape on the right.

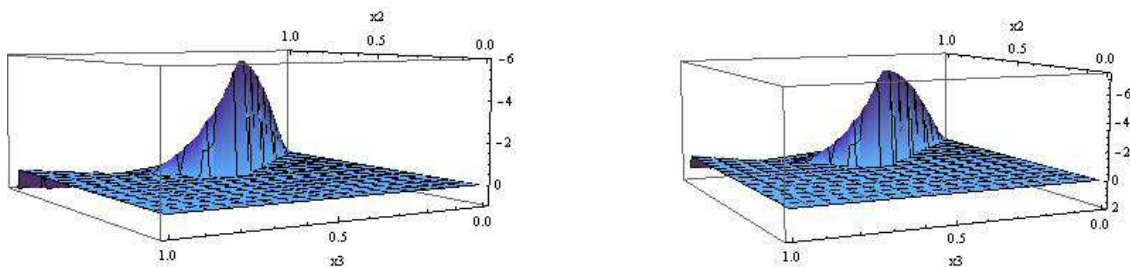

Figure 20. *A* on the left, *B* configuration on the right for the \bar{M}_9 -driven interaction term.

The shapes are peaked in the flat configuration.

Obviously, having presented all the shapes due to each individual interaction, one might proceed with the study of the shape of linear combinations of them, much in the spirit of the orhtogonal shape recently introduced [38]. On the other hand, we are using approximated methods for three of the four configurations under scrutiny and it is therefore not a cautious step to infer new shapes from linear combinations of approximated ones, especially when delicate substractions are involved.

5.3. Some general considerations on the shapes of non-Gaussianities

From the above discussion we can read off some general qualitative features characterizing the shapes of the bispectrum of a generic single-field model of inflation:

- Two qualitatively very different kinds of shapes appear: equilateral and flat. As pointed out before, the next natural step would be to consider the shapes resulting from linear combination of the various interaction terms in the spirit of Ref. [38].
- In single field-models of inflation usually large non-Gaussianities are associated to equilateral shapes. In order to obtain a flat shape one needs to consider linear combinations of interaction operators such as what is done in [38] or models with an initial vacuum different from Bunch-Davies. Interestingly, in our case a flat shape emerges simply from individual operators generated by curvature-related terms.

When the flat shape appears, it does so in all four configurations considered. We stress this point because it implies that this result does not depend on the type of wavefunction one employs in the calculation, be it the DBI inflation solution, the ghost inflationary one and in the intermediate cases. The results of the DBI configuration are exact and easily reproducible with analytical methods. In fact, the DBI wavefunction is the usual solution of the standard single-field slow-roll inflation. Adopting such a wavefunction we may provide analytic results for the flat bispectra

$$\begin{aligned}
\langle \zeta_{k_1} \zeta_{k_2} \zeta_{k_3} \rangle_{\bar{M}_6} &= \frac{(60a^6b^2 + 11a^3b^5 + b^8 + (48a^6 - 4a^3b^3 - 3b^6)c^2 - 4b^4c^4) H^4 \bar{M}_6^2}{4a^9 \alpha_0^2 b^5 \epsilon^3 M_{\text{Pl}}^6}, \\
\langle \zeta_{k_1} \zeta_{k_2} \zeta_{k_3} \rangle_{\bar{M}_8} &= \frac{(15a^3 + b^3 + 3bc^2)(12a^6 + b^6 - 6b^4c^2 + 8b^2c^4 + 8a^3(b^3 - 2bc^2)) H^5 \bar{M}_8}{a^9 \alpha_0^3 b^6 \epsilon^3 M_{\text{Pl}}^6}, \\
\langle \zeta_{k_1} \zeta_{k_2} \zeta_{k_3} \rangle_{\bar{M}_9} &= \frac{3(15a^3 + b^3 + 3bc^2)(8a^6 + b^6 - 6b^4c^2 + 8b^2c^4 + 8a^3(b^3 - 2bc^2)) H^5 \bar{M}_9}{2a^9 \alpha_0^3 b^6 \epsilon^3 M_{\text{Pl}}^6},
\end{aligned} \tag{37}$$

where the overall momentum conservation delta has been omitted,

$$a = (k_1 k_2 k_3)^{1/3}; \quad b = k_1 + k_2 + k_3; \quad c = (k_1 k_2 + k_1 k_3 + k_2 k_3)^{1/2},$$

and α_0 is now the usual speed of sound:

$$\alpha_0 = -M_{\text{Pl}}^2 \dot{H} / (-M_{\text{Pl}}^2 \dot{H} + 2M_2^4) = c_s^2.$$

Note that all the three expression given above have a maximum precisely in the flat configuration ($k_1 = 1, k_2 = 1/2 = k_3$). What immediately stands out in Eq. (37) is the presence in the numerator of factors consisting of subtractions between generally positive k -symmetrized terms: it is this characteristic that selects a flat, rather than an equilateral shape, as one can readily verify by checking the bispectrum of the ‘‘equilateral’’ interaction terms.

The expression in Eq. (37) is exact in the DBI case and can be employed to get a shape qualitatively similar in the other three configurations. For practical purposes, we give below a very simple expression that very closely mimics the behaviour of the typical bispectrum contribution that generates flat shape

$$\langle \zeta_{k_1} \zeta_{k_2} \zeta_{k_3} \rangle_{\bar{M}} \sim \frac{(-k_1^2 + k_2^2 - k_3^2)(k_1^2 + k_2^2 - k_3^2)(-k_1^2 + k_2^2 + k_3^2)}{k_1^3 k_2^3 k_3^3 (k_1 + k_2 + k_3)^6} \tag{38}$$

- As a general rule, the terms which are going to generate a flat shape can be read off already at the Lagrangian level: indeed the flatness originates from the way the external momenta combine with each other and are summed over. Whenever mixed space derivatives act on a single π term and the mixing is repeated on at least another π field, the shape turns out to be flat (note that this criterium puts $\bar{M}_{6,8,9}$ contributions in the same, ‘‘flat’’ class, but correctly excludes apparently very similar ones such as $\bar{M}_{2,3,7}$).

6. Conclusions

The purpose of this paper was to employ a powerful tool such as effective field theory to obtain as general as possible a knowledge of primordial non-Gaussianities generated in a very general set-up of single field models of inflation. We have performed a study of the corresponding bispectra, in terms of both amplitudes and shapes. We extended the results existing in the literature in different ways. First, we have improved the treatment of the wavefunction describing the behaviour of the cosmological perturbations at second order in perturbation theory. Secondly, we computed the amplitude and the shape of bispectra for theories which interpolate between the most studied ones, *i.e.*, the DBI and the ghost models. Third, we have pointed out the importance of the curvature-induced operators. Their study has revealed that large non-Gaussianities may be generated with a flat shape which is quite uncommon for single-field models of inflation so far analyzed. It would be interesting to identify in which (class of) theories of inflation such operators arise. A natural way to extend our findings is to study with the same philosophy the four-point correlator, the trispectrum, and to identify, for instance, those classes of inflationary models where the bispectra are suppressed, but large trispectra are generated. These issues are currently under investigation [32].

Acknowledgments

It is a pleasure to thank X. Chen, P. Creminelli and M. Pietroni for illuminating discussions. This research has been partially supported by the ASI Contract No. I/016/07/0 COFIS, the ASI/INAF Agreement I/072/09/0 for the Planck LFI Activity of Phase E2. MF would like to thank Claudio Destri for insightful discussions and for kind encouragement during the completion of this work. MF is happy to thank the Physics Department of the University of Padua for warm hospitality.

References

- [1] G. F. Smoot *et al.*, *Astrophys. J.* **396**, L1 (1992)
- [2] C. L. Bennett *et al.*, *Astrophys. J.* **464**, L1 (1996).
- [3] K. M. Gorski, A. J. Banday, C. L. Bennett, G. Hinshaw, A. Kogut, G. F. Smoot and E. L. Wright, *Astrophys. J.* **464** (1996) L11.
- [4] D. N. Spergel *et al.* [WMAP Collaboration], *Astrophys. J. Suppl.* **170**, 377 (2007) [arXiv:astro-ph/0603449].
- [5] E. Komatsu *et al.* [WMAP Collaboration], arXiv:0803.0547 [astro-ph].
- [6] E. Komatsu *et al.*, arXiv:1001.4538 [astro-ph.CO].
- [7] V. Acquaviva, N. Bartolo, S. Matarrese and A. Riotto, *Nucl. Phys. B* **667**, 119 (2003) [arXiv:astro-ph/0209156].
J. M. Maldacena, *JHEP* **0305** (2003) 013 [arXiv:astro-ph/0210603].
- [8] N. Bartolo, S. Matarrese and A. Riotto, *Phys. Rev. D* **65**, 103505 (2002) [arXiv:hep-ph/0112261].
F. Bernardeau and J.-P. Uzan, *Phys. Rev.* **D66**, 103506 (2002), hep-ph/0207295.
F. Bernardeau and J.-P. Uzan, *Phys. Rev.* **D67**, 121301 (2003), astro-ph/0209330.
P. Creminelli, *JCAP* **0310**, 003 (2003), astro-ph/0306122.
N. Bartolo, S. Matarrese and A. Riotto, *JCAP* **0401**, 003 (2004) [arXiv:astro-ph/0309692].
N. Bartolo, S. Matarrese and A. Riotto, *Phys. Rev. D* **69**, 043503 (2004) [arXiv:hep-ph/0309033].
S. Matarrese and A. Riotto, *JCAP* **0308**, 007 (2003) [arXiv:astro-ph/0306416].
D. Seery and J. E. Lidsey, *JCAP* **0506** (2005) 003 [arXiv:astro-ph/0503692].
D. Seery and J. E. Lidsey, *JCAP* **0509** (2005) 011 [arXiv:astro-ph/0506056].
G. I. Rigopoulos, E. P. S. Shellard and B. J. W. van Tent, *Phys. Rev. D* **73**, 083522 (2006) [arXiv:astro-ph/0506704].
- [9] X. Chen, R. Easther and E. A. Lim, *JCAP* **0804**, 010 (2008) [arXiv:0801.3295 [astro-ph]].
D. Langlois, S. Renaux-Petel, D. A. Steer and T. Tanaka, *Phys. Rev. D* **78**, 063523 (2008) [arXiv:0806.0336 [hep-th]].
F. Arroja, S. Mizuno and K. Koyama, *JCAP* **0808**, 015 (2008) [arXiv:0806.0619 [astro-ph]].
- [10] D. Babich, P. Creminelli and M. Zaldarriaga, *JCAP* **0408**, 009 (2004) [arXiv:astro-ph/0405356].
- [11] X. Chen, M. x. Huang, S. Kachru and G. Shiu, *JCAP* **0701**, 002 (2007) [arXiv:hep-th/0605045].
- [12] D. Seery, J. E. Lidsey and M. S. Sloth, *JCAP* **0701**, 027 (2007) [arXiv:astro-ph/0610210].
X. Chen, M. x. Huang and G. Shiu, *Phys. Rev. D* **74** (2006) 121301 [arXiv:hep-th/0610235].
D. Seery and J. E. Lidsey, *JCAP* **0701**, 008 (2007), astro-ph/0611034.
X. Chen, R. Easther, and E. A. Lim, *JCAP* **0706**, 023 (2007), astro-ph/0611645.
F. Arroja and K. Koyama, *Phys. Rev. D* **77**, 083517 (2008) [arXiv:0802.1167 [hep-th]].
D. Seery, M. S. Sloth and F. Vernizzi, *JCAP* **0903**, 018 (2009) [arXiv:0811.3934 [astro-ph]].
- [13] D. Boyanovsky, H. J. de Vega and N. G. Sanchez, *Nucl. Phys. B* **747**, 25 (2006) [arXiv:astro-ph/0503669].
S. Weinberg, *Phys. Rev. D* **72**, 043514 (2005) [arXiv:hep-th/0506236].
D. Boyanovsky, H. J. de Vega and N. G. Sanchez, *Phys. Rev. D* **72**, 103006 (2005) [arXiv:astro-ph/0507596].
M. S. Sloth, *Nucl. Phys. B* **748**, 149 (2006) [arXiv:astro-ph/0604488].
S. Weinberg, *Phys. Rev. D* **74**, 023508 (2006) [arXiv:hep-th/0605244].
M. S. Sloth, *Nucl. Phys. B* **775**, 78 (2007) [arXiv:hep-th/0612138].
D. Seery, *JCAP* **0711**, 025 (2007) [arXiv:0707.3377 [astro-ph]].
D. Seery, *JCAP* **0802**, 006 (2008) [arXiv:0707.3378 [astro-ph]].
A. Riotto and M. S. Sloth, *JCAP* **0804**, 030 (2008) [arXiv:0801.1845 [hep-ph]].
L. Leblond and S. Shandera, *JCAP* **0808**, 007 (2008) [arXiv:0802.2290 [hep-th]].
E. Dimastrogiovanni and N. Bartolo, *JCAP* **0811**, 016 (2008) [arXiv:0807.2790 [astro-ph]].
P. Adshead, R. Easther and E. A. Lim, *Phys. Rev. D* **79**, 063504 (2009) [arXiv:0809.4008 [hep-

- th]].
- D. Boyanovsky, C. Destri, H. J. de Vega and N. G. Sanchez, *Int. J. Mod. Phys. A* **24**, 3669 (2009) [arXiv:0901.0549 [astro-ph.CO]].
- L. Senatore and M. Zaldarriaga, arXiv:0912.2734 [hep-th].
- [14] For a review on non-Gaussianity, see, N. Bartolo, E. Komatsu, S. Matarrese and A. Riotto, *Phys. Rept.* **402**, 103 (2004) [arXiv:astro-ph/0406398].
- [15] see <http://planck.esa.int/>.
- [16] N. Mandolesi *et al.*, arXiv:1001.2657 [astro-ph.CO].
- [17] M. Liguori, E. Sefusatti, J. R. Fergusson and E. P. S. Shellard, arXiv:1001.4707 [astro-ph.CO].
- [18] L. Verde and S. Matarrese, *Astrophys. J.* **706**, L91 (2009) [arXiv:0909.3224 [astro-ph.CO]].
- [19] K. Koyama, arXiv:1002.0600 [hep-th].
- [20] N. Bartolo, S. Matarrese and A. Riotto, arXiv:1001.3957 [astro-ph.CO].
- [21] X. Chen, arXiv:1002.1416 [astro-ph.CO].
- [22] P. Creminelli, M. A. Luty, A. Nicolis and L. Senatore, *JHEP* **0612**, 080 (2006) [arXiv:hep-th/0606090].
- [23] C. Cheung, P. Creminelli, A. L. Fitzpatrick, J. Kaplan and L. Senatore, *JHEP* **0803**, 014 (2008) [arXiv:0709.0293 [hep-th]].
- [24] S. Weinberg, *Phys. Rev. D* **77**, 123541 (2008) [arXiv:0804.4291 [hep-th]].
- [25] C. Armendariz-Picon, T. Damour and V. F. Mukhanov, *Phys. Lett. B* **458**, 209 (1999) [arXiv:hep-th/9904075].
- [26] J. Garriga and V. F. Mukhanov, *Phys. Lett. B* **458**, 219 (1999) [arXiv:hep-th/9904176].
- [27] M. Alishahiha, E. Silverstein and D. Tong, *Phys. Rev. D* **70**, 123505 (2004) [arXiv:hep-th/0404084].
- [28] R. Holman and A. J. Tolley, *JCAP* **0805**, 001 (2008) [arXiv:0710.1302 [hep-th]].
- [29] P. D. Meerburg, J. P. van der Schaar and P. S. Corasaniti, *JCAP* **0905**, 018 (2009) [arXiv:0901.4044 [hep-th]].
- [30] J. R. Fergusson and E. P. S. Shellard, *Phys. Rev. D* **80**, 043510 (2009) [arXiv:0812.3413 [astro-ph]].
- [31] M. Liguori, E. Sefusatti, J. R. Fergusson and E. P. S. Shellard, arXiv:1001.4707 [astro-ph.CO].
- [32] N. Bartolo, M. Fasiello, S. Matarrese and A. Riotto, “Large non-Gaussianities in the the Effective Field Theory Approach to Single-Field Inflation: the Trispectrum”, to appear.
- [33] L. Senatore, *Phys. Rev. D* **71**, 043512 (2005) [arXiv:astro-ph/0406187].
- [34] C. Cheung, A. L. Fitzpatrick, J. Kaplan and L. Senatore, *JCAP* **0802**, 021 (2008) [arXiv:0709.0295 [hep-th]].
- [35] N. Arkani-Hamed, P. Creminelli, S. Mukohyama and M. Zaldarriaga, *JCAP* **0404**, 001 (2004) [arXiv:hep-th/0312100].
- [36] N. D. Birrell and P. C. W. Davies, “Quantum Fields In Curved Space,” *Cambridge, Uk: Univ. Pr. (1982)*
- [37] X. Chen, B. Hu, M. x. Huang, G. Shiu and Y. Wang, *JCAP* **0908**, 008 (2009) [arXiv:0905.3494 [astro-ph.CO]].
- [38] L. Senatore, K. M. Smith and M. Zaldarriaga, *JCAP* **1001**, 028 (2010) [arXiv:0905.3746 [astro-ph.CO]].
- [39] N. Bartolo, M. Fasiello, S. Matarrese and A. Riotto, to appear.
- [40] J. S. Schwinger, *J. Math. Phys.* **2**, 407 (1961).
- [41] R. D. Jordan, *Phys. Rev. D* **33**, 444 (1986).
- [42] E. Calzetta and B. L. Hu, *Phys. Rev. D* **35**, 495 (1987).
- [43] S. Weinberg, *Phys. Rev. D* **72**, 043514 (2005) [arXiv:hep-th/0506236].