

PACIFIC LINGUISTICS

Series B - No. 96

A GRAMMATICAL ANALYSIS OF MONO-ALU  
(BOUGAINVILLE STRAITS, SOLOMON ISLANDS)

by

Joel L. Fagan



Department of Linguistics

Research School of Pacific Studies

THE AUSTRALIAN NATIONAL UNIVERSITY

PACIFIC LINGUISTICS is issued through the Linguistic  
Circle of Canberra and consists of four series:

SERIES A - Occasional Papers  
SERIES B - Monographs  
SERIES C - Books  
SERIES D - Special Publications

EDITOR: S.A. Wurm

ASSOCIATE EDITORS: D.C. Laycock, C.L. Voorhoeve, D.T. Tryon, T.E. Dutton

EDITORIAL ADVISERS:

B.W. Bender

University of Hawaii

David Bradley

La Trobe University

A. Capell

University of Sydney

Michael G. Clyne

Monash University

S.H. Elbert

University of Hawaii

K.J. Franklin

Summer Institute of Linguistics

W.W. Glover

Summer Institute of Linguistics

G.W. Grace

University of Hawaii

M.A.K. Halliday

University of Sydney

E. Haugen

Harvard University

A. Healey

Summer Institute of Linguistics

L.A. Hercus

Australian National University

Nguyễn Đăng Liêm

University of Hawaii

John Lynch

University of Papua New Guinea

K.A. McElhanon

Summer Institute of Linguistics

H.P. McKaughan

University of Hawaii

P. Mühlhäusler

Linacre College, Oxford

G.N. O'Grady

University of Victoria, B.C.

A.K. Pawley

University of Auckland

K.L. Pike

Summer Institute of Linguistics

E.C. Polomé

University of Texas

Malcolm Ross

Australian National University

Gillian Sankoff

University of Pennsylvania

W.A.L. Stokhof

University of Leiden

B.K. T'sou

City Polytechnic of Hong Kong

E.M. Uhlenbeck

University of Leiden

J.W.M. Verhaar

Divine Word Institute,

Madang

All correspondence concerning PACIFIC LINGUISTICS, including  
orders and subscriptions, should be addressed to:

The Secretary  
PACIFIC LINGUISTICS  
Department of Linguistics  
Research School of Pacific Studies  
The Australian National University  
G.P.O. Box 4, Canberra, A.C.T. 2601  
Australia

Copyright © The Author

First Published 1986

Typeset by Anne Rees

Printed by A.N.U. Printing Service

Maps drawn by Theo Baumann

Bound by Adriatic Bookbinders Pty Ltd

The editors are indebted to the Australian National University for assistance in the  
production of this series

This publication was made possible by an initial grant from the Hunter Douglas Fund

ISSN 0078-754X  
ISBN 0 85883 339 5

## TABLE OF CONTENTS

	page
PREFACE	vii
CHAPTER 1: INTRODUCTION	
1. Mono-Alu: the area and previous research	1
1.1 Objectives	1
1.2 The nature of the data	4
1.2.1 Preparing the data for this analysis	5
1.2.2 Wheeler's grammatical notes	5
1.2.2.1 Phonology	5
1.2.2.2 Morphology	6
1.3 Theoretical orientation	8
1.3.1 Case grammar	8
1.3.2 Lexicase	9
1.3.2.1 Components of a lexicase grammar	10
1.3.2.2 Syntax	12
1.3.2.3 The sister-head hypothesis	13
1.3.2.4 Lexicase case relations and case forms	13
CHAPTER 2: POSSESSIVE CONSTRUCTIONS	
2. Introduction	15
2.1 Possession in Oceanic languages	16
2.1.0 Introduction	16
2.1.1 Inalienable possession in Oceanic	17
2.1.2 Alienable possession in Oceanic	17
2.1.2.1 Dominant possession	17
2.1.2.2 Subordinate possession	18
2.1.2.3 The syntax of alienable possession in Oceanic	18
2.2 Possessive constructions in Mono-Alu	19
2.2.0 Introduction	19
2.2.0.1 Terminology	20
2.2.0.2 The sample	20
2.2.1 Inalienable possession in Mono-Alu	21
2.2.1.1 Construction types	21
2.2.1.2 Constituent structure	24
2.2.1.3 Inventory of suffix-possessed nouns	26
2.2.2 Alienable possession in Mono-Alu	27
2.2.2.0 Introduction	27
2.2.2.1 The semantics of Mono-Alu alienable possession	28
2.2.2.2 Construction types	30
2.2.2.3 Constituent structure	32
2.2.2.3.1 Grammatical status of sa and e	32
2.2.2.3.2 Structures	33
2.2.2.4 Inventory of alienably possessed nouns	35
2.2.2.4.1 sa-possessed nouns	36
2.2.2.4.2 e-possessed nouns	36

2.2.2.5	Other types of alienable possessive constructions	37
2.2.2.5.1	Alienable constructions with locative ang	37
2.2.2.5.2	ena as an instrumental preposition	38
2.2.2.5.3	Other variant constructions	39
CHAPTER 3: MODIFIERS: ATTRIBUTES OF NOUNS		
3.	Introduction	41
3.1	Distribution of modifiers	42
3.1.1	Determiners	42
3.1.2	Modifiers	45
3.1.2.1	Modifiers with word-final na	45
3.1.2.2	Other modifiers	48
3.1.2.3	Nominal modifiers	50
3.2	The grammatical status of modifiers	51
3.2.0	Objectives	51
3.2.1	Morphological properties	51
3.2.2	Syntactic properties	52
3.2.2.1	Forms occurring as head nouns	53
3.2.2.2	Forms occurring in nominal positions in possessive constructions	54
3.2.2.3	Forms occurring in nominal positions in locative constructions	55
3.2.2.4	Forms occurring with modifiers of nouns	55
3.2.2.5	Forms occurring with determiners	56
3.2.2.6	Forms occurring as inflected verbs	57
3.2.2.7	Summary	58
3.3	Appositive constructions	58
3.4	Relative clauses	59
CHAPTER 4: EQUATIONAL SENTENCES AND NON-VERBAL STATIVE SENTENCES		
4.	Introduction	65
4.1	Equational sentences	66
4.1.0	Introduction	66
4.1.1	Equational sentences: noun phrases in juxtaposition	66
4.1.1.1	Construction types	66
4.1.1.2	Propositional structure	68
4.1.1.3	Alienable possessives as equational sentences	69
4.1.2	Equational sentences with ga	71
4.1.2.1	Construction types	71
4.2	Non-verbal stative sentences	74
4.2.0	Introduction	74
4.2.1	Construction types	75
4.2.1.1	Noun phrase and stative nominal in juxtaposition	75
4.2.1.2	Non-verbal stative sentences with ga	76
CHAPTER 5: VERBAL CONSTRUCTIONS		
5.	Introduction	79
5.1	Lexicase analysis of case marking systems	80
5.1.1	Case relations	80
5.1.2	Case forms and case markers	81
5.1.3	Subjects, objects, and transitivity	82
5.1.4	Assumptions	83
5.1.5	Ellipsis	83

5.2	Verbal constructions in Oceanic	84
5.2.0	Introduction	84
5.2.1	Word order in Oceanic	84
5.2.2	Verbal constructions in Oceanic	85
5.2.2.1	The proto-Oceanic 'verb-phrase'	85
5.2.2.2	Intransitive constructions in Oceanic	85
5.2.2.3	Transitive constructions	86
5.2.2.4	Incorporated object constructions	86
5.3	Verbal constructions in Mono-Alu	86
5.3.1	Inflectional affixes	86
5.3.1.1	Prefixes	87
5.3.1.2	Suffixes	87
5.3.2	Intransitive constructions	88
5.3.2.1	Sentence types and their constituents	88
5.3.2.2	Case marking	90
5.3.2.3	Summary	96
5.3.3	Transitive constructions	96
5.3.3.0	Introduction	96
5.3.3.1	Transitive suffixes	97
5.3.3.2	Transitive constructions	99
5.3.3.2.0	Introduction	99
5.3.3.2.0.1	Terminology	99
5.3.3.2.1	Case marking and word order in transitive sentences	100
5.3.3.2.2	Summary	108
5.3.4	'Semitransitive' constructions	109
5.4	Verbal derivation	112
5.4.1	The transitive suffix i	112
5.4.2	The transitive suffix ng	113
5.4.3	The causative prefix fa	114
5.4.4	The stative prefix ta	115
5.4.5	The reciprocal prefix fang	115
5.4.6	The prefix fero	116
5.4.7	The repetitive suffix male	116
CHAPTER 6: LEXICASE FORMALISATION		
6.	Introduction	117
6.1	Noun subcategorisation and redundancy rules	118
6.2	Verb subcategorisation and redundancy rules	126
6.3	Subcategorisation and redundancy rules for prepositions and postpositions	142
6.4	The omega rule	144
6.5	Case relation/case form summary with sample sentences	146
CHAPTER 7: CONCLUDING REMARKS		
7.	Introduction	149
7.1	Future research on Mono-Alu	149
7.2	An alternative analysis of case marking	152
ABBREVIATIONS		155
NOTES		155
BIBLIOGRAPHY		156
MAP		vi

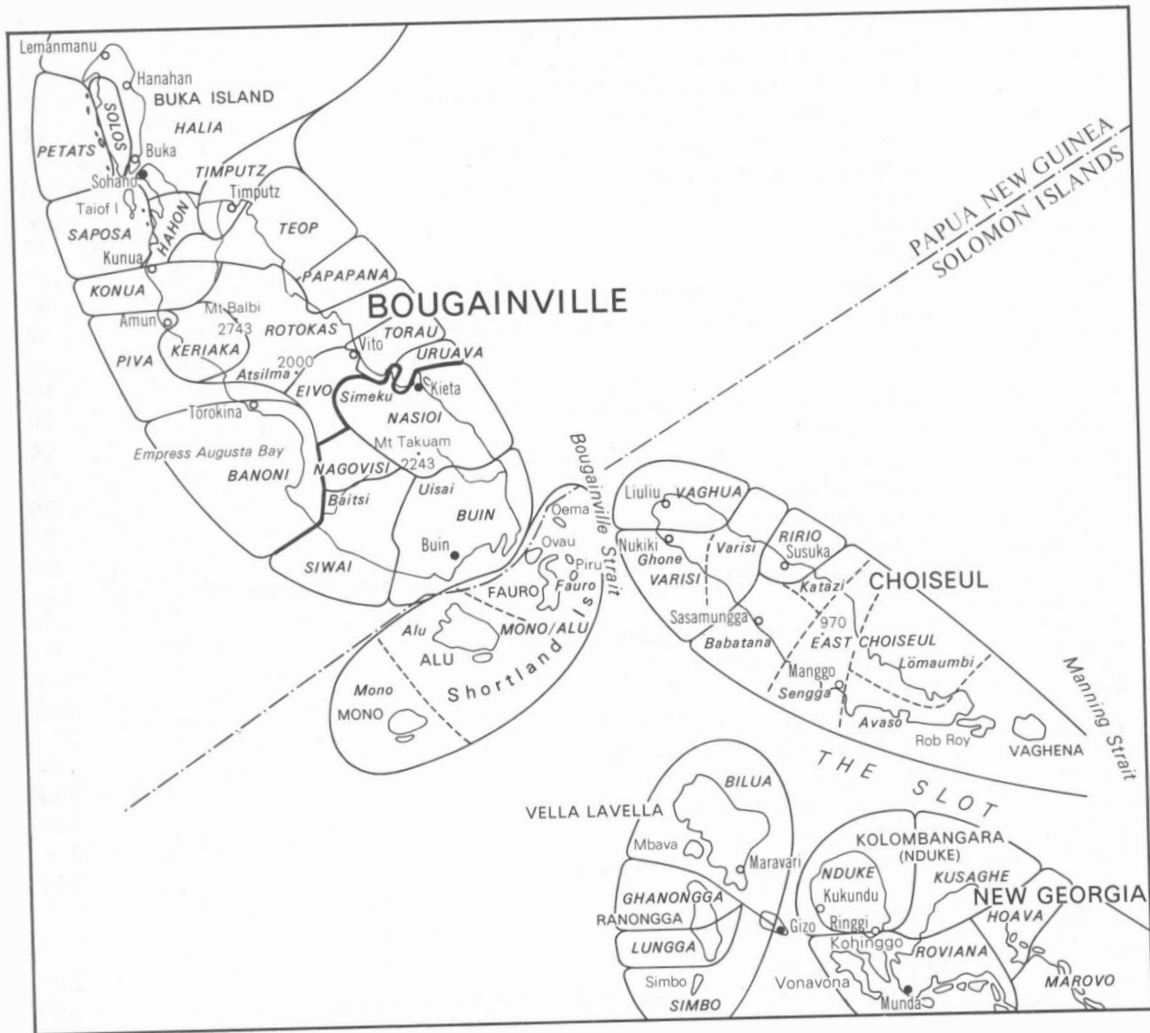

Mono-Alu and other languages of the Bougainville Straits area.

## PREFACE

This work was originally prepared as a thesis for the degree of Master of Arts in Linguistics at the University of Hawaii. The degree was conferred in 1979. George W. Grace chaired my thesis committee, and Roderick A. Jacobs, Andrew K. Pawley, Lawrence A. Reid, Albert J. Schütz, and Stanley Starosta were members. I am happy to have this opportunity to thank all of them. Stanley Starosta deserves special thanks, however, for the careful attention he gave to all aspects of the analysis.

I have also benefited from the help of other individuals. Pete Lincoln played an instrumental role in getting the project started by identifying Wheeler's texts as a valuable source of linguistic data. Frank Lichtenberk read and commented on early versions of several sections. Bob Hsu's *Showcase* program made it possible to test the rules presented in Chapter 6. He was also a valuable source of advice in writing the computer programs that were used to organise the data.





## CHAPTER 1

### INTRODUCTION

#### 1. MONO-ALU: THE AREA AND PREVIOUS RESEARCH

In 1908 and 1909 Gerald Camden Wheeler spent ten months on the islands of Mono and Alu in the Bougainville Straits for the purpose of carrying out ethnological research. His activities there included collecting a number of folktales in the local language. He later published 70 of these in his monograph *Mono-Alu folklore*.<sup>1</sup> The texts he collected provide the data on which this work is based.

Mono and Alu (also called Treasury and Shortland), together with Fauro, are the three major islands in the Bougainville Strait, which separates Bougainville Island from Choiseul and the New Georgia group to the south-east. According to Wheeler (p.vii) and Lincoln (1976a:200), the populations of these islands all speak the same language, which is commonly referred to as Mono-Alu. Neither Wheeler's discussion nor the tales themselves contain any information indicating how the speakers refer to their own language. For this reason, I have continued to use the name Mono-Alu.

According to Lincoln's summary of linguistic research on Austronesian languages in the Bougainville area (Lincoln 1976a:206-207), accounts of Mono-Alu were limited to a few wordlists and comparative comments before Wheeler began his studies. Published accounts of Mono-Alu grammar are limited to a short summary by Ray (1926) based on Wheeler's data, and the comments included in Wheeler's glossary and his notes to the texts. An undated typescript by Boch (n.d.) gives a summary of morphology. His account of grammar is about equal in coverage to Wheeler's, however, if all of Wheeler's notes and glossary entries are taken into consideration. Boch also compiled a dictionary to which I have unfortunately not had access.

#### 1.1 Objectives

Of the more than 50 Austronesian languages spoken in the Solomon Islands, few have been described in detail. Likewise for most of these, little language data has been collected. Mono-Alu is an exception due to the work of Wheeler. The folktales he recorded form one of the largest collections of unanalysed language data from the area.

A major objective of this study has been to make this data easily accessible for use in grammatical analysis and comparative work. Another objective has been to use the data as the basis for a preliminary analysis of the structure of the language. The analysis is necessarily a preliminary one because the nature of the data imposes some severe restrictions on the extent and accuracy of the analysis. Since the textual data cannot be augmented and clarified by consulting with a native speaker, certain questions about the syntactic structure of the language will necessarily be left unanswered and some aspects of the analysis will inevitably be incomplete.

Given such limitations, it would be unreasonable to attempt a definitive description of the grammar of Mono-Alu based on this data alone. Instead, I have set a more realistic goal, which is simply to find out as much about the structure of the language as possible from the data provided by the texts. This information, though admittedly incomplete, may be useful for comparative work, and will certainly be useful in planning a field study of the language.

An exhaustive inventory and preliminary analysis of the constructions in the texts should indicate clearly where further analysis is needed, and should suggest how further research should proceed in order to be maximally productive.

A large part of this study consists simply of an inventory, classification, and description of the different constructions found in the texts. In addition, these descriptions are accompanied by a discussion of the grammatical status of the constituents involved, and an analysis of the hierarchical relationships of the constituents. These analyses of constituent structure are based on the approach to grammatical description provided by the lexicase theory of case grammar (see section 1.3).

One of the most prominent characteristics of this model of grammatical description is its attention to systematic analysis and formalised representation of grammatical structures. Another of its prominent characteristics is that its theoretical claims about the possible form of a grammar and the nature of grammatical relations place strong restrictions on the range of structural descriptions that can be assigned to a sentence.

Both of these characteristics are positive attributes of a grammatical theory.<sup>2</sup> A highly formalised account of a grammar, however, requires that a large amount of detailed information be available to the analyst. Thus a highly formalised approach to grammatical description is most appropriate to a well described language, or one for which a large amount of data is available.

It could be said, then, that a highly formalised approach like lexicase is to some extent inappropriate to an exploratory study such as this one. From one point of view this is true, because a consistent formal analysis has no place for a considerable number of loose ends which cannot be tied in without access to further data. From another point of view, however, the theoretical claims proposed by lexicase are beneficial to a preliminary study such as this. The claims are beneficial because they provide a principled method for choosing an appropriate analysis from among the various possible alternative analyses of a grammatical construction. In addition, the process of attempting to formalise an analysis will draw clearly into focus those parts of the analysis that are incomplete, and the areas which need further investigation.

It has not been possible to fit all of the various grammatical constructions found in the texts into a formal lexicase analysis. In many cases, an attempt to formalise the description of a particular construction would be an attempt to make an explicit and detailed statement without having explicit and detailed information on which to base it. Such statements would be unwarranted and very likely misleading.

Rather than attempt to make formal statements about segments of the grammar which cannot yet be adequately analysed, I have restricted my formalised statements to those aspects of Mono-Alu grammar which are well represented by the texts, and which therefore have been analysed fully enough to warrant a formal treatment.

The role of lexicase theory in this study has been to guide the investigation of syntactic structure, but only to the extent that it is appropriate to the quality of the data at hand. No attempt has been made to restrict the discussion to aspects of the grammar that fit easily into the lexicase framework. Rather, my objective has been to provide a descriptive account of all the data, complemented by as much syntactic analysis and generalisation as the data allows. The extent and accuracy of such analysis varies considerably in the study, however, depending on how well represented the different constructions are. In some cases a fairly complete formal account is possible. In others, the data allows little more than a prose description of the elements of a construction, presented together with the few available examples of the construction.

In the remainder of this chapter I will describe the nature of the data and how it was presented and analysed by Wheeler. Then I will explain how it was prepared for use in this analysis. A statement on the theoretical orientation of this study concludes Chapter 1. Chapters 2 through 5 describe the major grammatical structures of Mono-Alu as they are represented in Wheeler's texts.

Chapter 2 is concerned with possessive constructions, and compares Mono-Alu's possessives with the constructions Pawley (1973) has reconstructed for proto-Oceanic and those discussed by Lynch (1973).

Chapter 3 describes nominal modifiers: simple forms which occur as attributes of nouns, appositive constructions, and relative clauses.

Chapter 4 treats equational sentences and non-verbal stative sentences.

Verbal constructions are analysed in Chapter 5 and are compared with those reconstructed by Pawley (1973, 1978) for proto-Oceanic. Intransitive sentences are discussed first, followed by transitive and 'semitransitive' constructions. A brief discussion of verbal derivation ends Chapter 5.

Chapter 6 is a formal statement of certain aspects of the analysis presented in Chapters 2-5. As noted earlier, the necessarily inconclusive nature of much of the analysis is not well suited to formal treatment, so not all of the claims made in the earlier chapters have been restated formally in the lexicase analysis.

The formalised lexicase analysis defines the classes of lexical items hypothesised to exist in Mono-Alu, defines the inflected forms of nouns and verbs, the structure of noun phrases, and the case frames of verbs. Verbal derivation as discussed in Chapter 5 does not receive formal treatment.

Chapter 7 is a statement of some brief concluding remarks.

## 1.2 The nature of the data

Following each tale in Wheeler's collection, he notes whom he obtained it from. The majority were told or retold to Wheeler by a single informant, a blind man names Bitiai. Several of the texts were first collected from storytellers other than Bitiai, but were later retold to Wheeler by Bitiai. Thus it appears from Wheeler's account that the majority of the texts, as they stand in his monograph, form a relatively homogenous sample of speech from a single speaker. The fact that there is some consistency in the data is, of course, beneficial to an analysis based on it.

Wheeler was not interested in the texts for purposes of linguistic analysis. Instead, he was interested in the ethnology of the area and in collecting folktales for use in comparative studies of folklore. This being the case, his organisation of the tales was not designed with ease of linguistic analysis in mind. In fact, his presentation makes the data next to inaccessible for systematic linguistic analysis.

After the introduction, the book is broken into three major parts:

(1) summaries in English of the tales, (2) a section consisting of the Mono-Alu texts, followed in a separate section by English translations of the texts, and followed by a third separate section of notes to the texts. The third major division consists of a Mono-English glossary followed by several short indexes.

Wheeler's translations do not include morpheme-by-morpheme glosses. Only free translations into English are given. Thus morpheme glosses had to be supplied by referring to the glossary in conjunction with the free translations and Wheeler's comments on grammatical structure, which are given in the notes to the texts. These notes contain comments to the tales which are largely irrelevant to linguistic analysis, as well as some discussion of grammar.

Also in the notes and glossary, Wheeler sometimes comments on the possible source of unusual forms which appear in the texts. These are usually thought to be from Buin, a nearby area on the southern Bougainville coast, or words from 'Old-Alu'. Wheeler's impression is that Old-Alu was spoken on the island of Alu before the islands in the strait were conquered by the people of Mono (p.vii). That there are words which differ from the usual Mono forms cannot be argued, but the idea that they are relics of an Old-Alu language is based on little supporting evidence.

The 70 texts vary in length from two to over 200 printed lines. The texts are numbered sequentially and broken into paragraphs labelled with letters. The sentence examples cited in this study are referenced according to text and paragraph number. Thus a sentence labelled 66b indicates that the sentence comes from paragraph b in text number 66. The 6858 sentences contained in these texts fill 65 pages in Wheeler's book, exclusive of the English translations, which occupy another 94 pages.

Wheeler's treatment of Mono-Alu grammar is restricted to a one page preface to the glossary, comments scattered through the notes to the texts, and a limited account of morphology in the form of glossary entries. A summary of his grammatical notes is given in section 1.2.2.

### 1.2.1 Preparing the data for this analysis

The format of Wheeler's book would make it difficult to do a systematic analysis of the data it contains without extensive rearrangement. The first step of this study was to rearrange the data into an easily usable and readily accessible format. This was done by first putting the data into machine readable form (punched cards, initially), which made it possible to have the computer produce a version of all the texts in interlinear format. In addition, this made it possible to make concordances of the data, and to search and sort it automatically. Using the computer for searching, sorting, and displaying the data has made a much more thorough analysis possible.

The process of reformatting Wheeler's data consisted of the following steps:

- (1) Mono-Alu and English texts were entered on data cards, and referenced according to text and paragraph number. Sentence breaks for both Mono-Alu and English were entered as given by Wheeler. At this stage, the Mono-Alu texts and English translations were separate bodies of data.
- (2) The next step consisted of matching Mono-Alu sentences with English sentences so that an interlinear text could be produced. Very rarely did the number of Mono-Alu sentences in a text correspond exactly to the number of English sentences in its translation. Thus sentence breaks had to be rearranged in order to create a one-to-one matching between the texts and translations. For this procedure, the Mono-Alu sentence breaks were taken as standard. Sentence breaks in the translations were reworked to match the texts. This alteration of sentence breaks accounts for some of the awkward English glosses.
- (3) After the sentences were matched one-to-one, the two sets of data were combined so that each Mono-Alu sentence was associated uniquely with an English sentence. Each of these combined records was assigned an identification number consisting of a one or two digit number indicating the text from which it was taken, one or two letters indicating the paragraph within the text, and a unique four digit number (1-6858) assigned sequentially from the first sentence of text one to the last sentence of text 70 (excluding texts 30, 38, 40, 42, and 55 which are glossed in Latin). Every sentence can be quickly and easily traced to its original location in Wheeler's monograph.
- (4) With the data in this form it can be easily manipulated and formatted for a variety of purposes. Methods of searching and sorting will be described in the discussion of different construction types which follow.

### 1.2.2 Wheeler's grammatical notes

#### 1.2.2.1 Phonology

Virtually no discussion of Mono-Alu's phonological system is given by Wheeler, so his representation of the forms must necessarily be accepted as presented. His inventory of phonemes is as given in Figure 1.

Wheeler's comments with regard to this inventory consist of the following:

- (1) 'b and v are interchangeable'
- (2) 'd, r, and dr are interchangeable'
- (3) 'f and h are interchangeable'

(4) 'n is equivalent to n with a dull vowel in front, stressed n.' (The actual phonetic value of this symbol is unclear; it may be a syllabic nasal. Wheeler alphabetises it with ng, so it may somehow resemble a velar nasal. It occurs only preceding a, k, and t.)

His transcription also includes a few diacritics on vowels:

- (1)  $\bar{v}$ ; presumably to indicate length.
- (2)  $\check{v}$ ; presumably indicating a distinction between long and short vowels.
- (3)  $\acute{v}$ ; presumably to indicate stress.

CONSONANTS	p	t	k
	b,v	d,r,dr	g
	m	n	ng,'n
	f,h		
		l	
VOWELS	i	u	
	e	o	
	a		

Figure 1: Wheeler's inventory of phonemes

The meaning of these diacritics is not discussed by Wheeler, and they do not appear consistently in the texts. They do not appear to indicate phonemic distinctions.

In the permanent records of these texts, all diacritics and alternate spellings have been preserved. However, for sorting and searching purposes, b and v have been regularised to b, f and h to f, and d, r, and dr to r. In addition, all diacritics have been ignored for these purposes. This has made it possible to bring all the alternative forms of words together, while still preserving Wheeler's transcription as it stands in the original.

#### 1.2.2.2 Morphology

Wheeler's grammatical analysis is limited to a summary of (1) pronouns, (2) verb affixes indicating person, number, and tense, (3) possessive forms, and (4) an inventory of grammatical morphemes which is included as part of the glossary. The grammatical categories assigned to the items in Figure 2 are those used by Wheeler (p.370).

Several things should be noticed about the items in Figure 2:

- (1) Wheeler treats the 'nominative personal pronouns' as a series of independent pronouns, but the 'objective personal pronouns' as verb suffixes.

(2) The sa- and e- series of possessives seem to be considered by Wheeler to be a set of possessive pronouns. Elsewhere he refers to them as 'possessive adjectives' (p.347-348, note 67cc3).

(3) Wheeler indicates some variation in the form of third person singular objective suffixes, third person plural verb prefixes and suffixes, and first person plural exclusive possessives. No explanation for this variation is given.

PERSON	PERSONAL PRONOUN POSSESSIVES				VERB PREFIXES		
	NOM	OBJ	SUF	OTHER	PAST	FUTURE	
1s	mafa	-afa	-gu	sagu	egu	fai-	fana-
2s	maito	-o	-ng	sang	eng	oi-	ona-
3s	---	-i,-ng	-na	sana	ena	i-	ena-
1pI	maita	-ita	-ra	sara	era	tai-	tara-
1pE	mani	-ami	-mang -ma	samang sama	emang ema	ami-	ama-
2p	maang	-ang	-mia	samia	emia	ang-	emia-
3p	---	-ri -iri	-ria	saria	eria	iri- re-	eria- rea-

Figure 2: Summary of Wheeler's verb affixes, pronouns, and possessives

Following is a summary of the grammatical morphemes recognised by Wheeler and listed in his glossary. The categories are those used by Wheeler. His 'infixes' are actually derivational prefixes or suffixes which occur together with other derivational or inflectional affixes.

#### VERB AFFIXES

Prefixes:	ang	relative prefix, alternate forms an, ai, a'nta
	fa	causative prefix, fa becomes f before a, alternate form ha
	ta	infix or prefix showing action or state
Infixes:	fa	infix denoting completion
	fang	<i>one another</i> (reciprocal infix), alternate form fan
	fero	<i>elsewhere, to somewhere else</i>
	isa	<i>together, at the same time</i> , alternate form sa
	male	<i>again</i> (also occurs independently)
	mea	makes a plural
	meka	<i>till tired, for a very long time</i> , alternate form meko

Suffixes:	ai	<i>there, away</i>
	ma	<i>hither, thither</i> , alternate form ama

## NOUN SUFFIXES

a	<i>place where or whither</i> , alternate form ang occurs after a
ng	added to the first of two names gives the meaning <i>and</i> , alternate form m
ua	denotes <i>addition, and, with</i>

## OTHER FORMS

-a	<i>of</i> , especially before -ang, alternate forms an, ang, aan
afa-	<i>what?</i>
-ata	often found after verbs and other words, alternate forms eta, ita, ota, uta
ga	particle, most often after the first word in a sentence, untranslatable; <i>so, therefore</i> at the beginning of a sentence, also used with pronoun forms to emphasise them: gafa, gami, gai, gaina, gang etc.
-nana	equivalent to copula, alternate form nina
-titi	strengthens the idea of repetition or duration

The distribution and function of these and other forms will be discussed in relevant sections of the analysis which follows. The forms listed above, together with other words in the glossary, provided the basis for assigning morpheme-by-morpheme glosses to the sentences used in this study.

### 1.3 Theoretical orientation

#### 1.3.1 Case grammar

Case grammar is an approach to grammatical description which assumes that there is a small number of universal syntactic-semantic relationships which define and describe the nature of the relationships which hold among verbal and nominal constituents in a sentence (Fillmore 1968:5, 21, 24). The method of defining and representing syntactic relationships in a grammar is the primary characteristic that distinguishes case grammar from other theories of grammar.

Chomsky's discussion of grammatical functions and grammatical relations (Chomsky 1965:68-74) is an attempt to formally define traditional notions such as subject, direct object, predicate and main verb. His definitions are purely syntactic, configurational ones stated in terms of dominance relationships among constituents in tree structures. Because of their configurational definitions, these grammatical relationships have little semantic content. That is, the semantic relationships among constituents in a particular grammatical relation may not be consistent from one sentence to another. Jackendoff recognises this point in his statement that '... the 'natural' grammatical relations such as subject and object do not correspond



in any simple fashion to the understood semantic relations' (Jackendoff 1972:25). This is essentially an observation that there is not a one-to-one correspondence between grammatical relations and the 'semantic functions' the nominal constituents of a sentence have with respect to the verb or other nominal constituents. The knowledge that a noun phrase stands in a particular grammatical relation in a sentence is not fully predictive of its semantic function in the sentence. It appears that Chomsky's grammatical relations do not make a clear distinction between semantic relations or 'roles' and the syntactic devices that indicate them.

In order to compensate for the lack of this distinction, Fillmore (1968) explicitly recognises a distinction between semantic relations among sentence constituents and the devices that signal them. Fillmore's cases, or case relationships, identify the syntactic-semantic relationships which hold between a verb and its associated nominal constituents. These appear to be situationally or perceptually defined relationships which can presumably be recognised by observing the roles played by the entities in a situation which is described by a sentence. Fillmore's case relationships are primarily semantic relationships, and are assumed to be applicable to all languages (Fillmore 1968:21, 24).

Fillmore distinguishes case relationships clearly from case forms. Case forms are syntactic devices, peculiar to individual languages, which signal the presence of a case relationship (Fillmore 1968:21).

In considering the differences between Chomsky's treatment of grammatical relations, and Fillmore's discussion of cases (case relationships) and case forms, the important contrasts to note are as follows. Chomsky's grammatical relations are defined only in configurational terms. If they have any semantic content, it is implied only by the traditional names applied to the relations he defines. Fillmore takes the opposite extreme by recognising two distinct entities: (1) semantically defined case relationships, whose definitions depend little if at all on syntactic criteria, and (2) case forms which are syntactic indicators of case relationships. The meaning-bearing relationships (cases, case relationships) are kept distinct from their syntactic manifestations (case forms). This makes it possible to formally recognise the fact that there is not a one-to-one correspondence between grammatical relations like subject and object and the more basic, universal, case relationships (Fillmore 1968:25).

Fillmore's theory of case grammar differs significantly from the lexicase theory of case grammar which provides the theoretical orientation of this study. The following section will discuss the general form of a lexicase grammar and its major theoretical claims, and will briefly discuss the more significant differences between lexicase and Fillmorean case grammar.

### 1.3.2 Lexicase

A flow diagram of the components of a lexicase grammar (Figure 3), together with a few basic definitions, provide a reference point around which an outline of lexicase theory can be organised.

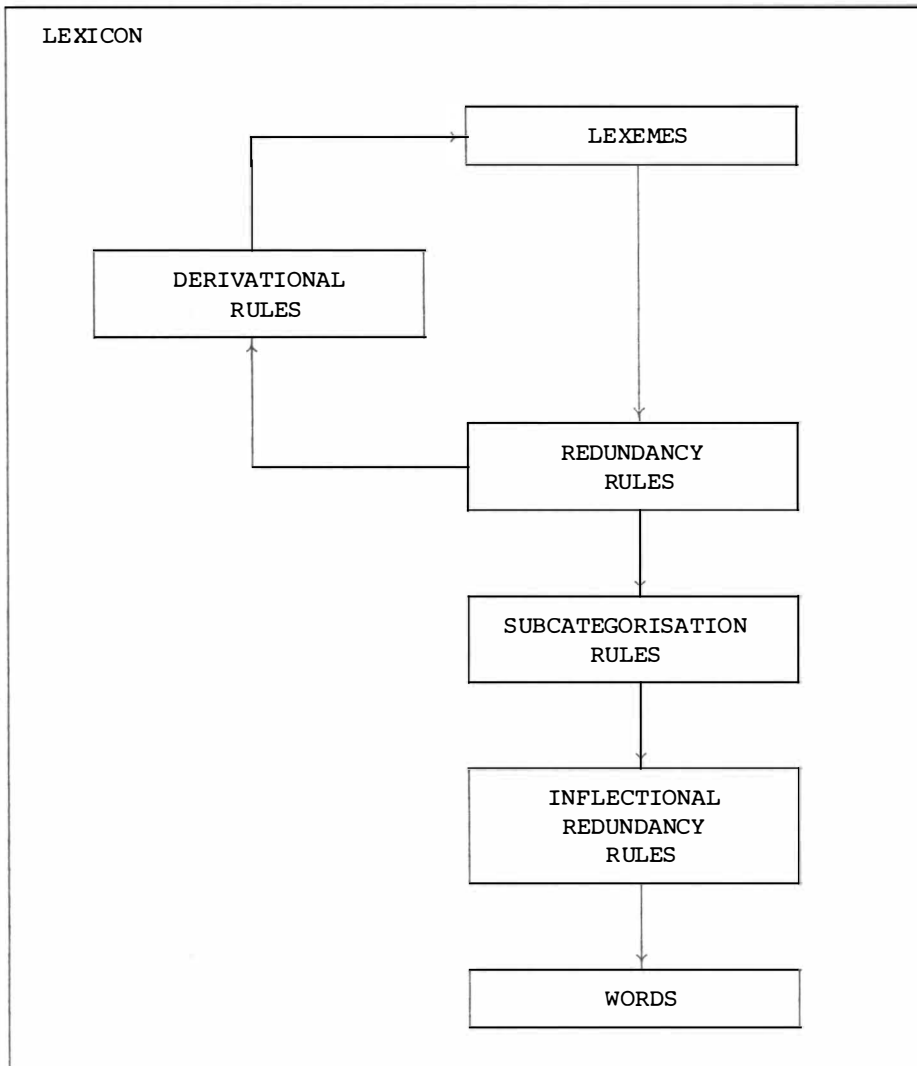

Figure 3: Components of a lexibase grammar

### 1.3.2.1 Components of a lexibase grammar<sup>3</sup>

Though the components displayed in Figure 3 may not appear to conform to more traditional conceptions of what a grammar should include, lexibase's approach to the essentials of grammatical description differs little from traditional approaches. Lexibase views *grammar* as '... the set of all general statements that can be made about the internal structure and external distribution of words in sentences' (Starosta 1978:3). That is, grammar is a statement about *morphology*, '... the internal structure of words ...' (ibid.), and *syntax*, '... an account of the distributions of words in sentences ...' (ibid.). The similarity of this view to traditional approaches to grammatical description becomes evident when these terms are compared with analogous ones discussed by Hockett (1954).<sup>4</sup>

Though lexemes and redundancy rules are the first two components listed in Figure 3, it is convenient to begin a discussion of the form of a lexicase grammar by explaining the function of subcategorisation rules. The reason for beginning here is that the form of the first two components depends, at least in the process of writing a lexicase grammar, on the form of the entities defined by the subcategorisation rules.

An essential step in making generalisations about the distribution of words in sentences is recognising that lexical items can be grouped together on the basis of shared syntactic properties. The shared syntactic properties of a set of lexical items define a syntactic class to which they all belong. The importance of recognising such classes should be obvious; if this were not done, the syntactic distribution of each lexical item would have to be stated individually.

Lexicase formally defines syntactic categories by a system of subcategorisation rules. These rules define all the linguistically relevant categories of lexical items and state the membership of each one. The rules are stated in terms of formal syntactic and/or semantic features shared by members of each class.

The hierarchical nature of the classes defined by subcategorisation rules makes it possible to state generalisations about the syntactic properties of members of each class. This is done by determining which features are redundant, that is, by determining which features can be predicted by the presence of other features. Generalisations of this kind are expressed by redundancy rules.

Redundancy rules are formalised statements which simply provide that if a feature X is present in the lexical representation of an item, then another feature Y can be predicted from it and will therefore be added to the feature inventory of that lexical item. Specifying redundant features is of course the major function of these rules. But, together with the subcategorisation rules, they also clearly indicate which features are not predictable and therefore must be stated explicitly in the lexicon. Thus another important function of redundancy rules is that they help to specify the form of a lexeme as it must appear in the lexicon.

A lexeme is an abstract form whose representation contains no redundant information with regard to its syntactic or semantic properties. A lexeme, in this sense, is equivalent to Matthews' 'word in sense two', which he calls an abstract unit usually characterised in terms of syntactic classification or of meaning (Matthews 1974:21). A lexeme is sharply distinguished from its phonological representation and inflected forms. John Lyons (1968:197-198) uses the term lexeme in essentially the same sense.

In addition to information about its phonological form and semantic properties, each lexeme carries all features defined by the subcategorisation rules which are common to its syntactic category, except those that are redundant and therefore can be predicted. Subcategorisation rules, then, do not perform any real operations on lexemes in the way that redundancy rules do. Redundancy rules actually add features to lexical representations. Subcategorisation rules merely define classes of lexical items which have certain syntactic properties.

The subcategorisation rules discussed up to this point have been lexical subcategorisation rules. These can be distinguished in function (but not form) from inflectional subcategorisation rules. Inflectional subcategorisation

rules define the inflected forms of lexemes. Thus, a lexeme can be viewed as an abbreviation for all of its inflected forms. As will be discussed below in the section on verb subcategorisation, each lexical representation of a Mono-Alu verb which requires its Patient to be realised by the accusative case form is an abbreviation for 98 inflected forms. That is, each verb of this category can theoretically take any of 14 verb prefixes in combination with any of seven suffixes, which makes a total of 98 possible inflected forms. Though all these forms are theoretically possible, it is likely that there are semantic restrictions which would reduce the number of combinations that actually occur.

Like lexical redundancy rules, inflectional redundancy rules add predictable information to the inflected form of a lexical item. It is often the case that inflectional features of a lexical item are realised morphologically. A special kind of inflectional redundancy rule, called a morphophonemic rule, adds this morphological information to the abstract lexical representation.

Fully inflected forms of a lexeme have the status of words, equivalent to Matthews' 'word in sense three' (1974:24-26), and Lyons' 'grammatical word' (1968:196-197). Syntax, in a lexicase grammar, is concerned with specifying the allowable distribution of words in this sense.

### 1.3.2.2 Syntax

In a lexicase grammar, the distribution of words in sentences is specified entirely with reference to contextual and non-contextual features of words in conjunction with one governing principle, the sister-head hypothesis (see section 1.3.2.3). An inflected lexical item, after undergoing all lexical and inflectional redundancy rules, is fully specified with regard to the contexts in which it can occur. Complete specification of contexts is insured by a universal redundancy rule, called the 'omega rule', which also makes phrase structure rules unnecessary (see section 6.4 and Starosta 1978:4-5).

A lexicase lexicon is composed of lexemes and a system of lexical rules. This lexicon, together with the sister-head hypothesis, fulfil one requirement imposed on a generative grammar. That is, a lexicase grammar is 'a system of rules that in some explicit and well-defined way assigns structural descriptions to sentences' (Chomsky 1965:8). A further requirement, however, is that a structural description should supply all information necessary to assign a semantic interpretation to the sentence it describes (*ibid.*:16).

A structural description, then, should show what elements of a sentence are related, and describe the nature of the relationships. This implies that the grammar should define all possible kinds of relationships that hold among sentence constituents, and should provide a way of indicating explicitly which relationships hold among which constituents. A lexicase grammar meets this further requirement through its use of case relations.

Since the sister-head hypothesis plays such an important role in the lexicase theory of case grammar, and will be referred to throughout the following discussion, it will be described next.

### 1.3.2.3 The sister-head hypothesis

The sister-head hypothesis constitutes a strong universal claim concerning the nature of grammatical relations. The hypothesis proposes that:

- (1) 'grammatical relations obtain only between the syntactic head of a construction and the heads of its sister constituents', and
- (2) 'all syntactic subcategorisation of words is indicated in the lexicon by means of contextual features on those lexical items which occur as heads of their constructions', and
- (3) 'contextual features refer only to inherent features (that is, non-contextual features) of 'sister-heads', lexical heads of sister constituents' (Starosta n.d.a.:74-75).

Several terms which appear in this hypothesis require definition, namely 'grammatical relation', 'sister constituent', and 'head of a construction'. The last two terms are defined formally by Starosta (n.d.a.:77), so only a brief discussion will be given here. The first term, however, deserves more thorough discussion.

In essence, any two (or more) constituents which are directly dominated by the same node are sister constituents. In informal terms, the head of an endocentric construction is the single obligatory element of the construction. Exocentric constructions have more than one head; that is, more than one obligatory constituent.

With credits to Chomsky, Starosta (n.d.a.:74) notes that a selectional restriction between two sentence elements indicates the presence of a grammatical relation between those elements. Presumably this refers to Chomsky's discussion (Chomsky 1965:68-74) of grammatical relations in which he concludes that of the great variety of grammatical relations that can be defined in his configurational terms (dominance hierarchies), the only linguistically significant ones are those which also involve selectional restrictions.

This type of selectional restriction can be thought of in the following fashion. A selectional restriction exists between elements in positions A and B in a construction if the syntactic properties of the element in position A place restrictions on the occurrence or form of an element in position B. If this notion of selectional restriction is accepted, the term 'grammatical relation', as it is used in the above statement of the sister-head hypothesis, can be taken to mean more strictly that a selectional restriction can exist only between a construction head and the head of a sister constituent.

### 1.3.2.4 Lexicase case relations and case forms

Lexicase case relations differ significantly from Fillmorean case relations as discussed above (see section 1.3.1). Whereas Fillmore's case relations can be identified by observing the relationships among entities in an objective situation, both the objective situation and the syntactic properties of the lexical items used to describe the situation must be considered when identifying lexicase case relations.

This approach proposes that two different grammatical constructions which represent the same objective situation may require that different relationships be recognised among sentence elements. This view accounts for the fact that a single event can be described from different perspectives.

The inventory of case relations used in this study is drawn from a set proposed by Starosta (1977). These case relations and their definitions are given below in the discussion of Mono-Alu verbal constructions (chapter 5).

Case forms in a lexicase grammar are not language specific syntactic devices, as they are in Fillmorean case grammars (Fillmore 1968:21). Instead they are taken to be universally recognisable syntactic devices which are expressed in different languages by different case markers.

Given that case forms are universal, it is possible to compare the correspondence between case forms and case relations among different languages. This assumption has led Starosta to the conclusion that there appear to be some significant universal patterns in the correspondence between case relations and case forms (Starosta 1973:3).

It appears that this proposal would require the assumption that there is some formal method of recognising which case markers of a particular language correspond to which members of the universal set of case forms. Devising such a method would not be a trivial matter. Some of the difficulties met in this study have been concerned with determining the relationship between case markers and case forms.

Lexicase case markers correspond closely to Fillmore's case forms in that they are language specific syntactic devices which signal the presence of case relations.

## CHAPTER 2

### POSSESSIVE CONSTRUCTIONS

#### 2. INTRODUCTION

Possession is expressed in Mono-Alu by three different grammatical constructions: one 'inalienable' and two 'alienable' constructions. These are similar to constructions found in many other Oceanic languages. In order to place this description of Mono-Alu's possessive system within a wider context, I will first summarise some general characteristics of Oceanic possession as analysed by Pawley (1973) and Lynch (1973). The discussion of Mono-Alu's system will then be cast within this framework, and points of variance and similarity will be discussed.

With regard to the inalienable (or suffix-possessed) possessive constructions, the following discussion will propose that the suffix-possessed noun must be the head of the construction. Syntactic support for this conclusion is based on the observations that (a) the possessed noun is the only obligatory element of the construction, (b) the nominal possessor and the possessive suffix of the possessed noun must agree in person and number, and (c) there is agreement in person and number between the inflectional affixes of verbs and suffix-possessed nouns. In order to specify these types of agreement (b and c) lexicase theory requires that the suffix-possessed noun be the head of the possessive construction.

The relationship of possession between the possessed noun and possessor is represented formally by assigning the case relation feature [+COR] (Correspondent) to the nominal possessor. This feature indicates that the nominal possessor stands in a relationship of association to its construction head (the suffix-possessed noun). That is, the possessor 'corresponds', in a certain sense, to the suffix-possessed noun.

The discussion of alienable possessive constructions first addresses the problem of determining the grammatical status of the 'possessive markers' *sa* and *e*.

Because both *sa* and *e* occur with the same set of possessive suffixes as do the suffix-possessed nouns in inalienable constructions, because they occur in analogous positions in syntactic structures, and because they function as heads of noun phrases, it is concluded that *sa* and *e* can most accurately be classified as suffix-possessed nouns. Further syntactic evidence that *sa* and *e* are nouns is drawn from the observation that they, like other nouns, must carry features indicating plurality and person in order to account for agreement with verb affixes.

Like the suffix-possessed nouns in inalienable constructions, it is proposed that *sa* and *e* (with possessive suffixes) must be construction heads since they appear to be the only obligatory element in alienable possessive constructions. The nominal possessor and possessed noun, then, must be analysed as attributes of the suffix-possessed head, *sa* or *e*. The possessive relationship between the possessor and head is again represented by the case relation feature [+COR], as in inalienable constructions. The relationship between the head and its possessed noun attribute is assumed to be an appositive, or 'equational' relationship, where the equivalence is presupposed rather than asserted. The possessed noun attribute carries the case relation feature [+PAT] (Patient), indicating that it stands in a relationship of apposition to the suffix-possessed head.

Further details of and support for these proposals will be given in sections 2.2.1 and 2.2.2.

## 2.1 Possession in Oceanic languages

### 2.1.0 Introduction

Andrew Pawley (1973) has reconstructed three major possessive constructions for POC (proto-Oceanic); he refers to these as inalienable, dominant, and subordinate possession. The latter two are often grouped together into a larger category called alienable possession.

There has been considerable discussion among Oceanic linguists regarding the circumstances under which these different constructions are used. As pointed out by Pawley (1973:167), traditional analyses have described the use of different constructions in terms of grammatical gender, or classes of nouns. Nouns of a particular class were described as occurring in only one particular possessive construction. This approach assumes that there is no overlap in class membership, and therefore that a single noun would never occur in more than one construction type.

John Lynch (1973) has shown that the assumption of grammatical gender is an inadequate explanation for the use of the different possessive constructions. With a number of examples from four Melanesian languages, he has shown that many nouns often occur in more than one construction type with definite and non-random differences in meaning. Pawley (1973:181, note 36) also notes that a survey of Samoan by C. McDonald has shown that most nouns can occur in more than one type of possessive construction in that language. Lynch's conclusion, with which Pawley (1973:167) would appear to agree, is that the lexical features of a noun do not determine the type of possessive construction it can appear in. Rather, the use of different constructions expresses a difference in '... the nature of the relationship between it (the possessed noun) and the possessor and the kind of attitudes the possessor has towards it' (Lynch 1973:84-85). For the purposes of this study Lynch's conclusion will be accepted, since the available data for Mono-Alu, while it is adequate to indicate that Mono-Alu's system fits into the general pattern of Oceanic possession, is not accompanied by the details of meaning which would be required to argue persuasively either for or against this position.

Pawley reconstructs three possessive constructions for POC. These are distinguished by the 'possessive particle' or 'possessive marker' (Pawley 1973:154) which occurs in each construction. For inalienable constructions,



there is no overt morpheme; Pawley calls this \*zero-marking. The reconstructed marker for dominant possession is \*na, and for subordinate possession, \*ka.

As noted above, the semantic limits of all these constructions are not precise, and vary to some extent from language to language. Nonetheless, it is possible to recognise a general range of relationships which can be expressed using each one.

### 2.1.1 Inalienable possession in Oceanic

The inalienable construction occurs most often when the possessed noun is a natural part of a whole, a kinship relationship, or indicates a relative position with respect to the possessor. This construction consists minimally of the possessed noun with a suffix indicating the person and number of the possessor. The possessed noun is assumed to be the head of the construction (Pawley 1973:154-155).

Both Pawley and Lynch refer to this suffix as a pronoun, in order to distinguish this type of construction from those which include an independent nominal possessor. The suffixes are not pronouns in the usual sense, however, since they never function syntactically as independent nouns or noun phrases (see Hockett 1958:257). For purposes of the present study, these suffixes will be called possessive suffixes rather than pronouns.

For POC, Pawley reconstructs only the portion of the inalienable construction which contains the possessed nominal plus possessive suffix. Apparently the data is not adequate to reconstruct the form of a complete construction containing a nominal or independent pronominal possessor. Lynch (1973:71-72), however, gives examples of this type of construction which have the following form:

- (1)           (N[pssr])   N[pssd]-sfx

where N[pssr] is the nominal possessor, and N[pssd] is the possessed noun. The nominal possessor is optional, and in Aroma, one of the four languages in his sample, can also be a proper noun or independent pronoun. He also cites another construction which appears to allow only non-pronominal possessors:

- (2)           N[pssd]-sfx   N[pssr]

This occurs in Fijian. Lenakel has a similar one, except that the suffix is absent. Mono-Alu has constructions identical in form to both (1) and (2).

### 2.1.2 Alienable possession in Oceanic

#### 2.1.2.1 Dominant possession

Again with a proviso for exceptions, Pawley explains that \*na-marked dominant possession generally involves a relationship in which the possessor (a) owns or is in physical control of the head noun (possessed noun), (b) has a choice in the matter or possession, or (c) is the agent, deliberate actor, or voluntary experiencer of the action denoted by the head noun (Pawley 1973:158). Notice that as in the inalienable constructions, the possessed noun is assumed to be the head of the construction.

Pawley also notes that several languages do not have a reflex of \*na, but instead have a semantically parallel marker reconstructed as \*a. Reflexes of this form are present in Central and Milne Bay Districts of Papua (Pawley 1973:160).

In Mono-Alu, the possessive marker which fills many of the semantic functions of \*na as described above, takes the form sa. According to Peter Lincoln's compilation of tentative sound correspondences for languages of the northern Solomons, POC \*n is reflected in Mono-Alu by n and l (Lincoln 1976b:429, and insert). Thus while sa has a semantic function similar to \*na, it does not appear to be a reflex of the same morpheme. It is possible, however, that further comparative work could lead to a different conclusion.

### 2.1.2.2 Subordinate possession

Proto-Oceanic \*ka marked a possessive relationship described by Pawley as 'edible and subordinate possession'. He suggests that it is difficult to postulate a common meaning for \*ka possession which unites all of its uses, though the uses do fall into two general types: (1) edible, and (2) subordinate or uncontrolled. Things edible fit into the first category, as do things closely associated with food, such as gardens, reefs, and trees. In the subordinate sense, situations indicated by the head (possessed) noun which are not controlled by the possessor occur in \*ka marked constructions. This includes circumstances such as a possessor's sickness, death, or tiredness, over which he normally has little control (Pawley 1973:161-163). This type of relationship is also noted by Lynch, where he explains that in subordinate constructions the possessor often stands in a 'patient' relationship to the possessed nominal rather than in an 'actor' relationship as is the more usual case for dominant possession (Lynch 1973:93).

The Mono-Alu marker which corresponds semantically to POC \*ka is e. According to Lincoln's tentative correspondences, POC \*k is reflected in Mono-Alu as zero, k, and g (Lincoln 1976b:429, and insert). These correspondences suggest the possibility that Mono's e consists of \*k reflected as zero and \*a reflected as e. This should be regarded as a very tentative suggestion, however, since little is known about the vowel correspondences, and the above suggestion does not consider the different environments of \*k reflexes in Mono-Alu.

### 2.1.2.3 The syntax of alienable possession in Oceanic

For the syntax of \*na and \*ka possessives, Pawley reconstructs a construction of the form:

$$(3) \quad N[\text{pssd}] \quad \left\{ \begin{array}{l} *ka \\ *na \end{array} \right\} -\text{sfx}$$

with a preposing rule to produce the widely attested sequence:

$$(4) \quad \left\{ \begin{array}{l} *ka \\ *na \end{array} \right\} -\text{sfx} \quad N[\text{pssd}]$$

Notice that this structure does not include an independent nominal possessor. Pawley suggests that the full alienable possessive construction which can, in all likelihood, be reconstructed for POC is retained for the most part in

Bauan Fijian. The complete construction consists of an independent nominal possessor (personal or common) in addition to the suffixed possessive marker and possessed noun. Bauan constructions which have a suffixed possessive marker are of the form:

$$(5) \quad \left\{ \begin{array}{l} *ka \\ *na \end{array} \right\} -sfx \quad N[pssd] \quad N[pssr]$$

As will be discussed below, a few of Mono-Alu's alienable constructions are of this form. The more common ones, however, are of the same form as a construction found in two languages analysed by Lynch (1973:72-75). In these, the nominal possessor is the first element of the construction.

$$(6) \quad N[pssr] \quad \left\{ \begin{array}{l} *ka \\ *na \end{array} \right\} -sfx \quad N[pssd]$$

In all the languages in his sample, the nominal possessor (N[pssr]) can be a common noun. In one, Aroma, an independent personal pronoun can occur in this position. Pronouns also occur commonly in this position in Mono-Alu.

It is appropriate to mention one final point before moving on to an account of Mono-Alu possessives. There appears to have been little effort among Oceanic linguists to determine the syntactic status of the alienable possessive markers, though they occur widely in Oceanic languages. Lynch (1973:72) calls them 'special possessive morphemes', while Pawley (1973:72) refers to them as possessive 'markers' or 'particles'. Pawley also suggests that the marker, together with the suffix, forms an 'independent possessive pronoun' (1973:166). I will suggest below that they are not pronouns, or special particles or morphemes. Rather, they appear to behave syntactically much like suffix-possessed nouns, and therefore should be placed in the same grammatical category as suffix-possessed nouns.

## 2.2 Possessive constructions in Mono-Alu

### 2.2.0 Introduction

Wheeler's texts show that Mono-Alu has constructions which correspond to the three major possessive construction types reconstructed for proto-Oceanic. Their general forms will be outlined here. Variations on this general form, and characteristics which differ from the POC reconstructions, will be discussed in the sections which follow.

INALIENABLE POSSESSION: (N<sup>1</sup>) N<sup>2</sup>-pssr,  
where N<sup>1</sup> is an optional possessor, and N<sup>2</sup> is the possessed noun. pssr is a suffix indicating the person and number of the possessor.

DOMINANT POSSESSION: (N<sup>1</sup>) sa-pssr (N<sup>2</sup>),  
where pssr is a suffix which indicates the person and number of the possessor. This set of suffixes is identical to the set that occurs in inalienable constructions. N<sup>1</sup> is the nominal possessor, and N<sup>2</sup> is the possessed noun, both of which occur optionally.

SUBORDINATE POSSESSION: (N<sup>1</sup>) e-pssr (N<sup>2</sup>),  
where pssr, N<sup>1</sup>, and N<sup>2</sup> function as mentioned above for dominant possession.

The suffixes which indicate the person and number of the possessor are listed in Figure 4 (based on Wheeler p.370) along with their corresponding personal pronouns.

PERSON	POSSESSIVE SUFFIX	PERSONAL PRONOUN
1s	gu	mafa
2s	ng, (m)	maito
3s	na	(none)
1pI	ra	maita
1pE	mang, (ma)	mani
2p	mia	maang
3p	ria	(none)

Figure 4: Possessive suffixes and personal pronouns

Notice in Figure 4 that there is some variation in the suffixes for second person singular, and first person plural exclusive. A few sentences occur with the parenthesised suffixes. An explanation for these variant forms has not yet been found. Variation in the form of final nasals is common however in many other forms.

### 2.2.0.1 Terminology

In accordance with the foregoing summary of possessive constructions in Oceanic languages, the terms 'inalienable', 'dominant', and 'subordinate' possession will be used to indicate three different formally (and for the most part semantically) distinct possessive constructions. They are not intended to suggest that the use of possessive constructions in Mono-Alu is governed by a gender system. 'Alienable' possession refers to both dominant and subordinate possession. The term 'suffix-possessed' will sometimes be used as an alternative name for inalienable possession.

In contrast to the use of the term 'pronoun' in discussions by both Pawley and Lynch, in this study, the term will refer only to forms which occur in the same range of syntactic environments as nouns and noun phrases. This usage is in accordance with traditional definitions of the term (see Hockett 1958:257, Pearson 1977:26). The possessive suffixes, then, will not be treated as pronouns.

The following discussion will frequently make use of the term 'nominal possessor'. This term is intended to refer to the most general class of nouns, which includes proper nouns and pronouns as well as common nouns. When the distribution of pronouns or proper nouns differs from that of common nouns, the difference will be discussed explicitly.

### 2.2.0.2 The sample

Sentences containing possessive constructions were retrieved from the corpus by using a computer searching procedure. The searching procedure was designed by taking into consideration the fact that all possessive constructions contain at least one of the following:

- (1) a word beginning with sa and ending in a possessive suffix (see Figure 4),  
or  
(2) a word beginning with e and ending in a possessive suffix, or  
(3) a word ending in a possessive suffix, but not beginning with sa or e.

Constructions containing forms of type (1) and (2) are Mono-Alu's alienable possessive constructions, and were retrieved from the corpus by making a concordance of all and only forms consisting of an initial sa or e followed immediately by a sequence of characters identical in form to one of the possessive suffixes.

Constructions containing forms of type (3) are Mono-Alu's inalienable constructions. Sentences containing these forms were retrieved by making a concordance of all forms which end in a sequence of characters identical in form to a possessive suffix. Forms beginning with sa or e were excluded from this search, since they were obtained by the first procedure. Unfortunately, this procedure also concurs a large number of forms that are not possessives, but nevertheless end in the same sequence of characters as the possessive suffixes. Irrelevant forms were excluded from the analysis.

The decision as to which forms should be included and which should be excluded presented few problems. Most word-final sequences of characters which are not possessive suffixes but which happen to be identical in form to possessive suffixes can easily be recognised as being part of another morpheme or word which could not easily be interpreted as a possessed noun in the context in which the form occurs. For example, the concordance retrieved all forms with the locative suffix ang since it ends in ng, identical with the second person singular possessive suffix. Few if any of these forms, however, could accurately be treated as second person singular possessives. The only problematic cases are the modifiers which will be analysed in chapter 3. Many of these end in na (identical with third person singular possessive), and a few in other possessive suffixes such as gu (first singular), and ria (third plural). The possibility that these forms are possessives is considered in chapter 3.

These two searching procedures assure that all relevant examples from Wheeler's texts have been included in this analysis of Mono-Alu's possessive system.

## 2.2.1 Inalienable possession in Mono-Alu

### 2.2.1.1 Construction types

Three types of suffix-possessive constructions occur in Wheeler's texts.

- (a) N[pssd]-sfx

This construction consists simply of a noun marked by a possessive suffix. The nominal possessor to which the suffix refers is not expressed. Of the three types of suffix-possessive constructions, this is by far the most common.

Examples:

1827	maito	kai-gu	oi-golu
15e	2s	brother-1s:pssv	2s:nfut-eat
	<i>you swallowed my brother</i>		

6826	leako-ng	apea		
67cc	<i>magic-2s:pssv</i>	<i>lacking</i>		
	<i>thou hast no magic of thine</i>			
	<i>(you have no magic, your magic is lacking)</i>			
60	ena-tele	toto-na		
1e	<i>3s:fut-give</i>	<i>legs-3s:pssv</i>		
	<i>she gave her her legs</i>			
4402	kai-ra	ivai	ena-golu	
44d	<i>brother-1pI:pssv</i>	<i>now</i>	<i>3s:fut-eat</i>	
	<i>he will eat our brother now</i>			
136	natu-mang	fina		
1n	<i>child-1pE:pssv</i>	<i>where?</i>		
	<i>where is our child?</i>			
1140	too-mia	olatu		
9f	<i>head-2p:pssv</i>	<i>taboo</i>		
	<i>your heads are taboo</i>			
2834	i-iolo	ga	natu-ria	
22k	<i>3s:nfut-grow</i>	<i>abs</i>	<i>child-3p:pssv</i>	
	<i>their child grew up</i>			

Constructions of type (a) are identical in form to the portion of the inalienable construction which Pawley has reconstructed for POC.

(b) N[ pssr ] N[ pssd ]-sfx

Here, the suffix-possessed noun is of the same form as those in type (a) constructions. This construction differs from type (a) only in that the nominal possessor is present and occurs to the left of the possessed noun. The possessor and the possessive suffix must agree in person and number. The nominal possessor in this construction can be a common or proper noun, or an independent pronominal form. Pronouns that occur in this position are those listed in Figure 4.

Examples:

1831	mafa kai-gu	i-lapu	sa-ma	toloo
15e	<i>1s</i>	<i>brother-1s:pssv</i>	<i>3s:nfut-kill</i>	<i>thing-1pE:pssv</i>
	<i>our eel has slain my brother</i>			
2461	mafa natu-gu	i-mera-i-afa	ma	
20e	<i>1s</i>	<i>child-1s:pssv</i>	<i>3s:nfut-bring-tr-1s</i>	<i>hither</i>
	<i>my child brought me</i>			
2270	i-gagana	ma	ga	batafa ifa-na
18a	<i>3s:nfut-go</i>	<i>hither</i>	<i>abs</i>	<i>woman</i>
	<i>sister-in-law-3s:pssv</i>			
	<i>the woman's sister-in-law came</i>			
6353	mani tua-mang	rarami	i-fa-pori	
66u	<i>1pE</i>	<i>grandfather-1pE:pssv</i>	<i>food</i>	<i>3s:nfut-caus-exist</i>
	<i>our own grandfather brought food into being</i>			

(c) N[ pssd ]-sfx N[ pssr ]

This construction differs from (b) in that the nominal possessor follows rather than precedes the possessed noun. Unlike types (a) and (b), type (c) occurs only with third person possessors. Since there appear to be no third person pronouns in this language, this construction is restricted to common and

proper noun possessors. The reversed word order and the fact that the range of allowable nominal possessors is restricted in this construction type suggests that it may differ in some way from the more common types (a) and (b). That is, the possessor may stand in a different syntactic relationship to the possessed noun in this type of construction. There may also be a difference in meaning, though the translations of the available texts suggest very little about the nature of this possible difference.

Three of the 28 sentences which contain this construction type suggest that the two nouns may stand in a relationship of apposition rather than possession.

For example:

351	i-peala	leva-na	alapa
3h	3s:nfut- <i>dung</i>	shoot-3s:pssv	yam
	<i>he dinged yam planting shoots</i>		
352	i-peala	leva-na	toitoi
3h	3s:nfut- <i>dung</i>	shoot-3s:pssv	banana
	<i>he dinged banana planting shoots</i>		

Instead of interpreting this as a possessive relationship with a gloss such as *shoots of the yam/banana plant*, it could be interpreted as an appositive relationship with a gloss such as *shoots which are yam/banana plants*.

This is a reasonable explanation for the difference in word order for these examples, especially in light of the fact that Mono-Alu has appositive constructions of this form which do not contain suffix-possessed nouns. Appositive constructions will be discussed in section 3.3.

Not all constructions of this form can be interpreted as appositives, however. This is demonstrated clearly by sentence 4591.

4591	i-afo-ri	nka-na	Manuka Banggara
46g	3s:nfut- <i>smell</i> -3p	mother-3s:pssv	Manuka Banggara
	<i>Manuka Banggara's mother smelled them</i>		

In this sentence, Manuka Banggara, a male, could not be interpreted as standing in a relationship of apposition to nkana *his mother*. In fact, this type (c) construction appears to be identical in meaning to the type (b) construction in sentence 4607.

4607	i-gagana	Manuka Banggara	nka-na
46h	3s:nfut- <i>go</i>	Manuka Banggara	mother-3s:pssv
	<i>Manuka Banggara's mother came</i>		

In addition to the three sentences (350, 351, and 352) which can reasonably be interpreted as appositives, there are several others which could be marginally interpreted as appositives. The majority of type (c) constructions, however, clearly indicate possessive relationships like the one in sentence 4591 above.

Another possible explanation of the fact that non-third person possessors do not occur in type (c) constructions is suggested by the syntactic properties of Mono-Alu pronouns (personal pronouns listed in Figure 4). Pronouns most commonly occur in sentence initial position. Where this does not hold true, they at least occur as the first constituent of a noun phrase.

In Wheeler's texts, 104 sentences contain type (b) possessive constructions, while only 29 contain type (c) constructions.

## Examples:

2066	fabiu-na	nife	biluau	tua-na	
16n	<i>grandchild-3s:pssv</i>	<i>snake</i>	<i>like</i>	<i>grandfather-3s:pssv</i>	
	<i>the snake's grandchild</i>	<i>was</i>	<i>like</i>	<i>his grandfather</i>	
2072	i-ua	ga	fabiu-na	nife	
16o	<i>3s:nfut-say</i>	<i>abs</i>	<i>grandchild-3s:pssv</i>	<i>snake</i>	
	<i>said</i>	<i>the snake's</i>	<i>grandchild</i>		
6275	Funiki	i-lafa-i	ga	fala-na	Tanutanu
66k	<i>Funiki</i>	<i>3s:nfut-hit-tr</i>	<i>abs</i>	<i>shoulder-3s:pssv</i>	<i>Tanutanu</i>
	<i>Funiki</i>	<i>hit</i>	<i>Tanutanu's</i>	<i>shoulder</i>	
793	i-tele-ri	ga	siopa-na	boo	
7k	<i>3s:nfut-give-3p</i>	<i>abs</i>	<i>liver-3s:pssv</i>	<i>pig</i>	
	<i>he gave them</i>	<i>the pig's</i>	<i>liver</i>		
4946	eang	natu-ria	nitu	tiga	suele i-mamata
49f	<i>the</i>	<i>child-3p:pssv</i>	<i>ghost</i>	<i>from</i>	<i>sleep 3s:nfut-wake up</i>
	<i>the child of the</i>	<i>nitu</i>	<i>[ghost]</i>	<i>woke up</i>	<i>from its sleep</i>

Since an inalienable construction which contains a nominal possessor in addition to the suffix-possessed noun has not been reconstructed for POC, the proto-form cannot be used as a point of comparison for Mono-Alu. Mono-Alu's constructions are similar in form, however, to the constructions described by Lynch and discussed above in section 2.1.1.

Mono-Alu type (b) is similar to construction (1) in section 2.1.1 with regard to word order and the fact that the nominal possessor can either be a common noun or independent pronoun. Likewise type (c) has the same word order as construction (2) in 2.1.1, and has a similar restriction on the class of the nominal possessor: neither allow independent pronouns, as far as can be discerned from the data given by Lynch.

Pawley (1973:154) notes that in some Oceanic languages the form of a possessive construction can vary depending on whether the nominal possessor is (1) a personal name, (2) a pronoun, (3) an animate common noun, or (4) an inanimate common noun. For Mono-Alu, however, the data from Wheeler's texts indicates that only the second of these four is relevant in formation of possessives. Both types (b) and (c) occur with personal name, human and non-human animate, and inanimate possessors. The only restriction indicated by the data is that type (c) does not allow independent pronominal possessors.

### 2.2.1.2 Constituent structure

Two characteristics of these constructions provide syntactic evidence for the form of their constituent structures. First, the possessed noun is the only obligatory constituent. Second, if the nominal possessor is present, the suffix of the possessed noun and the nominal possessor must agree in person and number.

The fact that the possessed noun is the obligatory constituent suggests that it is the head of the construction. This conclusion is supported, and in fact required, by the mechanisms which are available to specify agreement in a lexicase grammar. In lexicase, agreement is specified by assigning contextual features to head nouns. According to the sister-head hypothesis, these inflectional features can refer only to heads of sister constituents. The



contextual features of the lexical head of a construction require that the syntactic features of its attributes not violate certain conditions. It is important to remember that these co-occurrence restrictions work only in one direction, namely head-to-attribute, and not vice versa. The head of a construction places restrictions on the syntactic characteristics of its attributes. An attribute has no control over the syntactic characteristics of the head of its construction.

In order for the possessed noun and possessor to agree, then, the inflected possessed noun must be the head of the construction. Type (b) and (c) possessive constructions thus must have the constituent structures shown in structures (T1) and (T2).

Type (b) 6353  
(T1)

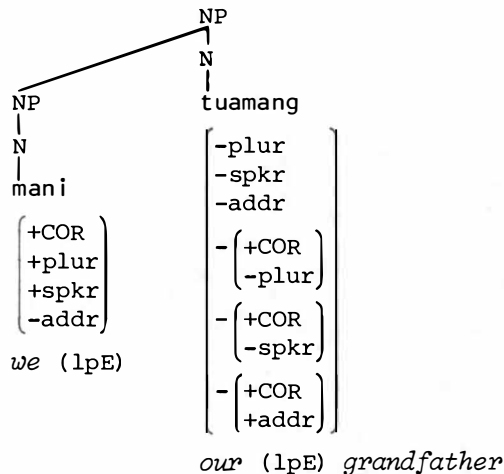

The word order of (c) requires a slightly different structure, T2.

Type (c) 2066  
(T2)

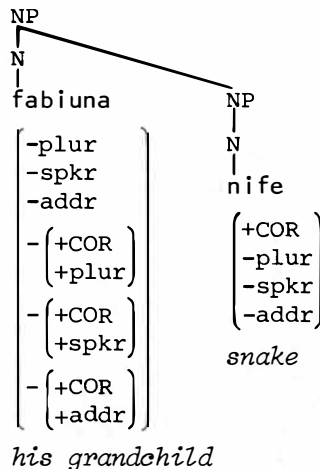

Notice that the fact that both word orders occur requires that the contextual features of the possessed noun not be directional. They must be able to refer to sister constituents in both directions. The possessed noun (head) will carry the case relation and case form features appropriate to its relationship

to the verb in the sentence in which it occurs. The nominal possessor carries the case relation feature [+COR] indicating that it is in a relationship of association with its head noun.

Further evidence that the possessor is an attribute of the possessed noun rather than the head of the construction is provided by the noun phrase mafa lafabigu *my grandchildren* as it occurs in sentence 1172, a type (b) construction (T3).

In order for ue to be inflected for third person plural subject agreement, it must have the feature specifications shown in structure (T3). These features state that ue, the head of the construction, can have no nominative sister constituents that are incompatible with its contextual features. The features are incompatible with any nominative sister constituent that carries person and number features other than third person plural. Thus, a nominative mafa could not be the head of the construction because all of its person and number features would conflict with the contextual features of the verb.

(T3)

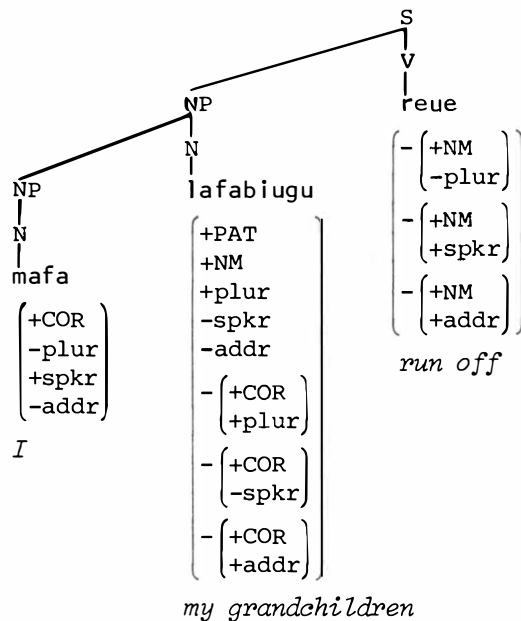

1172	mafa	la-fabiu-gu	re-ue	eta
9h	ls	pl-grandchild-ls:pssv	3p:nfut-run	?
	<i>my grandchildren have</i>		<i>run off</i>	

### 2.2.1.3 Inventory of suffix-possessed nouns

This is an inventory of all forms which occur in inalienable constructions in Wheeler's texts. Since there has been no opportunity to check or expand the list, it should not be viewed as an exhaustive list of suffix-possessed nouns in Mono-Alu. The possibility is also open that some of these forms can occur in other possessive constructions. This possibility cannot be conclusively tested, however, without consulting with a native speaker.

## (a) KINSHIP TERMS

apa	<i>father</i>	manai	<i>mother's brother</i>
fabiu	<i>grandchild</i>		<i>sister's child</i>
	<i>daughter-in-law</i>	natu	<i>child</i>
fafine	<i>sibling</i>	nka	<i>mother, mother's sister</i>
ifa	<i>sibling-in-law</i>	tau	<i>friend</i>
iloa	<i>co-wife</i>	tete	<i>grandmother</i>
kai	<i>brother</i>	tua	<i>grandfather</i>
loa	<i>father-in-law</i>		<i>father-in-law</i>
	<i>mother-in-law</i>		
	<i>son-in-law</i>		

## (b) BODY PARTS

aro	<i>back</i>	siopa	<i>liver</i>
ate	<i>chest, breast</i>	suma	<i>bones</i>
boto	<i>female genitals</i>	tia	<i>belly, womb</i>
ime	<i>arm</i>	too	<i>head</i>
lai	<i>forehead</i>	toto	<i>legs</i>
lua	<i>neck</i>	uli	<i>body</i>
masini	<i>blood</i>	ulili	<i>skin, tree bark</i>
mata	<i>eye, door</i>	uti	<i>penis</i>

## (c) LOCATION

gereti	<i>side</i>	papala	<i>side</i>
oloba	<i>midst, inside</i>	pola	<i>underneath</i>

## (d) OTHER

avesolo	<i>creeper</i>	ola	<i>smell of something</i>
keo	<i>sore on buttocks or anus</i>	pae	<i>fork in a road</i>
kofiso	<i>very small hole in something</i>	pinai	<i>footsteps</i>
lea	<i>name, namesake</i>	pipisia	<i>fastening material</i>
leako	<i>magical preparation</i>	poro	<i>existence</i>
leba	<i>a shoot or cutting of a plant</i>	sali	<i>talk, speech</i>
loe	<i>leaf</i>	sia	<i>urine</i>
manua	<i>sore</i>	tae, tai	<i>excrement</i>
moi	<i>firewood</i>	taro	<i>behalf, account, concern</i>
nitu	<i>ghost, spirit</i>	tibo	<i>self, alone</i>
nuna	<i>reflection of something</i>	tugafa	<i>ashes</i>
		utu	<i>head louse</i>

## 2.2.2 Alienable possession in Mono-Alu

## 2.2.2.0 Introduction

This section begins with a discussion of the semantic differences signalled by the use of dominant (sa-marked) versus subordinate (e-marked) constructions in Mono-Alu. Then four major construction types are described and compared with those reconstructed by Pawley for POC and those discussed by Lynch (1973).

Though there is a difference in meaning between sa and e marked constructions, the two forms occur in the same types of syntactic structures. For this reason, the discussion of construction types and analysis of constituent structure applies equally to both sa and e marked constructions.

### 2.2.2.1 The semantics of Mono-Alu alienable possession

With regard to the semantic difference between *sa* and *e* possessives in Mono-Alu, Wheeler notes repeatedly that *e*-marked possessives are generally used for things which are to be eaten or drunk (notes 8h3, 26a1, 45c2, 50d1, and 56a1). Of the 72 sentences in the texts which contain *e*-marked constructions, all but nine of them have possessed nouns which are food items, or items which the context of the folktale indicates are clearly intended to be eaten. These constructions thus correspond to the 'edible' portion of the semantic range covered by the subordinate possessive construction Pawley reconstructed for POC.

In addition to these, there are a few sentences which show that *e* possession is not restricted to use with edible items. The possessed noun in these examples is *onsala* *a kind of tree*, shown below as it occurs in sentence 2933.

2933      mafa e-gu                      onsala eang  
 26a        ls    *thing*-ls:pssv *tree*      *that*  
             *that is my* *onsala tree*

Wheeler's notes to this text (26a1, p.282; 26b4, p.283) as well as the context of the tale, indicate that *onsala* here was not intended to be eaten, but to be used for 'personal adornment'. That is, some part of the tree (perhaps leaves or bark) was to be worn as a decoration.

This usage is still within the range of subordinate possession as discussed by Pawley. He notes that POC may have extended the use of subordinate possession to 'intimate property', such as clothing (belts, skirts, loincloths), and hand carried weapons, etc. (Pawley 1973:163). The use of *onsala* as a body decoration fits this range of meaning.

As noted above in section 2.1.0, the data for Mono-Alu is not complete enough to provide strong support either for the idea that the choice of possessive constructions is governed by noun classes (a gender system), or for the idea that the different constructions signal a semantic distinction, with lexical or semantic classes of nouns being largely irrelevant. Nonetheless, Wheeler's texts contain at least one example of a noun (*toloo eel*) which occurs in both dominant and subordinate possessive constructions. The context of the folktales indicates that the two constructions carry an unmistakable semantic distinction:

5656      e-ra                      toloo fai-roro-i      ita  
 58a        *thing*-lpI:pssv *eel*    ls:nfut-*see*-tr ?  
             *I have seen an eel for us to catch*  
             (*I have seen our eel*)

In this tale two men go hunting eels to use as food, thus *toloo* occurs in an *e*-marked construction (see also Wheeler's note 58a4). In contrast with this is sentence 1763:

1763      sa-ra                      toloo i-iolo              ota  
 15b        *thing*-lpI:pssv *eel*    3s:nfut-*grow* ?  
             *our eel has grown*

The tale in which this sentence occurs is about two young boys who catch an eel and keep it as a pet. In this situation, it is their eel as property rather than as food, and therefore occurs in a *sa*-marked construction.

Sentence 6608 clearly indicates that edible items are not restricted to occurring in subordinate possessive (e-marked) constructions:

6608 gagalo-ai eng'nta ga sa-gu rarami  
 671 carry-dir ? abs thing-1s:pssv food  
 (you) carry my food always

The verbal constituent of this sentence is unusual and not fully understood, but the sentence shows that rarami *food* can be dominantly possessed. The context of this sentence is a situation where a woman is stealing food and gets caught by the owner. In such circumstances food, even though edible, can reasonably be viewed as property.

These sentences show that there is some overlap in the sets of nouns which occur in subordinate and dominant possessive constructions in Mono-Alu. As far as can be determined from the data in Wheeler's texts, however, it appears that there is no overlap between inalienable constructions and alienable constructions. The texts contain no examples of nouns that occur in inalienable constructions which also occur in alienable constructions without a possessive suffix. Sentence 1322 suggests that in order for a noun which normally occurs in an inalienable construction to occur in an alienable construction, it must first be suffix-possessed.

1322 i-sooto sa-na mata-na ang sisiako  
 10b 3s:nfut-shoot thing-3s:pssv eye/door-3s:pssv loc crab  
 it hit against the door of the crab

This sentence refers to an object which was thrown against the door of the place where a crab lived. The door is an inalienably possessed part of the crab's house. This possessive relationship is marked by mata's na suffix. In addition, the door is also the crab's property. This is an alienable possessive relationship marked by sana. An accurate but awkward literal gloss for this sentence would be *it hit against the crab's its door*, where *its* refers to the crab's house. This is directly analogous to a Lenakel construction cited by Lynch (1973:91).

Though there are no examples of overlap between alienable and inalienable constructions in the texts, one of Wheeler's notes (67cc3 p.347-348) says that the noun *leako magic*, *magical preparation* can be inalienably or alienably possessed, with a corresponding distinction in meaning. A construction such as *sang leako* would mean *your magic which you own*, or *your magical preparation*, while *leakong* would mean *your magic which comes from, is found in, or is associated with you*. He notes that the inalienable construction shows a more intimate relationship between the possessed noun and the possessor. This usage corresponds to the common usage of the inalienable construction to indicate a part to whole relationship. Here, the *magic* may be viewed as an integral part of its owner. These examples of overlap suggest that a thorough understanding of the use of Mono-Alu possessives will have to await a considerable amount of further research. Of particular interest would be a detailed investigation of the semantic distinctions signalled by the different constructions, with special attention to the nature of the relationship between the possessor and possessed noun.

## 2.2.2.2 Construction types

sa and e occur in four major types of construction:

(d) N[pssr]  $\left\{ \begin{array}{l} \text{sa} \\ \text{e} \end{array} \right\}$  -sfx N[pssd]

This construction consists of a nominal possessor followed first by sa or e with a possessive suffix, and then by the possessed noun.

Examples:

- 5496 mafa e-gu iana maranatu  
56b 1s *thing-1s:pssv fish kind:of:fish*  
*my fish is the maranatu*
- 1208 mani maito sa-ng famata ang ami-gagana ma  
9m lpE 2s *thing-2s:pssv village loc lpE:nfut-go hither*  
*we have come to your place*
- 2055 iri-soku nife sa-na kalofa a  
16n 3p:nfut-arrive snake thing-3s:pssv house loc  
*they came to the snake's meeting house*
- 4990 maita sa-ra poa emia-toka  
50a lpI *thing-lpI:pssv path 2p:fut-follow*  
*you take our path*
- 6148 mani sa-ma ka-kanega rekorekona  
65v lpE *thing-lpE:pssv pl-husband good*  
*our husbands are goodly men*
- 6144 maang sa-mia ka-kanega baoi i-fa-gaful-i-ri  
65v 2p *thing-2p:pssv pl-husband shark 3s:nfut-caus-finish-tr-3p*  
*a shark (the sharks) has (have) made an end of your husbands*

(e) N[pssr]  $\left\{ \begin{array}{l} \text{sa} \\ \text{e} \end{array} \right\}$  -sfx

This construction differs from type (d) only in that the possessed noun does not occur. This type is much less common than type (d), but is still represented adequately in the data.

Examples:

- 6397 mafa sa-gu rale soipa  
66aa 1s *thing-1s:pssv white:stone black:stone*  
*mine shall be hard white and hard black stones*
- 6401 Koriomu sa-na maluna  
66aa Koriomu *thing-3s:pssv soft*  
*Koriomu's was soft*
- 4729 nka-na sa-na ga  
48d *mother-3s:pssv thing-3s:pssv*  
*it is her mother's*
- 6060 mani sa-mang i-paite  
65m lpE *thing-lpE:pssv 3s:nfut-bad*  
*ours have (has) gone wrong*
- 6072 mani sa-mang i-popoati  
65m lpE *thing-lpE:pssv 3s:nfut-break*  
*ours have (has) broken*

(f)  $\left\{ \begin{array}{c} \text{sa} \\ \text{e} \end{array} \right\}$  -sfx N[pssd]

Here the nominal possessor is absent, but the possessed noun is present. This is the most common of the four major variants of the sa/e possessive construction.

Examples:

- 1339 e-gu niunu oi-aang  
10b *thing-1s:pssv coconut 2s:nfut-eat*  
*you ate my coconut*
- 2056 iri-fulau ga sa-na tala  
16n *3p:nfut-fear abs thing-3s:pssv men*  
*his men were afraid*
- 1763 sa-ra toloo i-iolo ota  
15b *thing-1pI:pssv eel 3s:nfut-grow ?*  
*our eel has grown*
- 2544 e-ma sanaka ona-fa-mako  
21d *thing-1pE:pssv food 2s:fut-caus-cook*  
*(you) cook our food*
- 4486 sa-mia tala iri-galo ama  
45d *thing-2p:pssv men 3s:nfut-carry hither*  
*your men brought it*
- 5247 re-neneo ga sa-ria beampeu  
52e *3p:nfut-tell abs thing-3p:pssv thing/property*  
*they told their property*

(g)  $\left\{ \begin{array}{c} \text{sa} \\ \text{e} \end{array} \right\}$  -sfx

Neither the possessed noun nor the nominal possessor occurs in this form of the construction. This is the least common of the four constructions discussed here, represented by only one fairly certain example, though there are other examples which may be of this type.

Example:

- 2905 sa-na boi tapoina  
23b *thing-3s:pssv day many*  
*thus he did always*

For proto-Oceanic, Pawley reconstructs an alienable construction which consists of a suffixed possessive marker followed by a possessed noun (see (4) in 2.1.2.3). His reconstruction does not include a nominal possessor. He suggests, however, that Bauan Fijian has probably retained the full construction, which includes an independent nominal possessor ((5) in 2.1.2.3).

The most common of Mono-Alu's alienable possessives, type (f), is of the same form as Pawley's reconstruction. However, Mono-Alu's type (d), the complete construction containing both the possessor and possessed nominal, differs from the Bauan construction which Pawley says is representative of a comparable POC construction (Pawley 1973:169). The constructions differ in the position of the nominal possessor. Mono-Alu's immediately precedes the possessive marker, while the Bauan possessor follows both the possessive marker and the possessed noun.

Mono-Alu's type (d) construction corresponds better to the Suau and Aroma examples given by Lynch (1973:72-73), which have the same word order as (d). His examples show that the independent nominal possessor in Aroma, like Mono-Alu, can be either a pronoun or a common noun.

### 2.2.2.3 Constituent structure

#### 2.2.2.3.1 Grammatical status of sa and e

As noted above in 2.1.2.3, the question of what grammatical category markers such as sa and e belong to has not been adequately discussed. Lynch (1973:72) suggests 'special possessive morpheme', while Pawley suggests 'possessive particle', 'possessive marker', and 'independent possessive pronoun' (Pawley 1973:154, 166). In order to make any progress toward understanding how these possessive constructions fit into the grammatical system as a whole, it is necessary to determine how their syntactic behaviour differs from and is similar to other lexical items. That is, an attempt should be made to determine what grammatical category sa and e (and corresponding forms in other Oceanic languages) belong to. A tentative conclusion as to their grammatical status can be reached by taking note of their distribution and association with other elements:

- (1) They always occur in association with possessive suffixes. These suffixes are identical in form to those which occur with suffix-possessed nouns.
- (2) The four constructions presented above show that the only obligatory constituent of a sa/e possessive construction is sa or e with its possessive suffix.

It is worth noting that the sa/e-plus-suffix element does not behave syntactically like any of the forms which are often called 'possessive pronouns'. For example, the English forms 'my' and 'your', which are most accurately classified as determiners (Quirk and Greenbaum 1975:101, 102, 105), always occur as attributes to a head noun. Thus these forms are not pronouns, strictly speaking. They are modifiers, or attributes, of the associated noun. On the other hand, the English forms 'mine' and 'yours' can accurately be called pronouns, since they function syntactically as independent noun phrases, and never occur with an attribute.

The syntactic behaviour of the sa/e element does not completely parallel either possessive determiners or possessive pronouns. This element is unlike a possessive pronoun because it can occur with an attribute, and is unlike a possessive determiner because it does not occur as an attribute to a noun, as evidenced by the four construction types listed above. These observations point toward the conclusion that the sa/e element cannot be categorised as a pronoun of any type.

Since sa and e occur with the same set of possessive suffixes as possessed nouns, occur in analogous positions in syntactic structures, and function as heads of noun phrases, it is reasonable to suggest that they are syntactically equivalent to possessed nouns and are therefore members of the same grammatical category as suffix-possessed nouns. The next section proposes a constituent structure analysis of alienable possessive constructions which treats them as complex noun phrases consisting of a head noun with one or more nominal attributes.



### 2.2.2.3.2 Structures

In construction types (d) and (e), the possessive suffix and nominal possessor must agree in person and number. As with the suffix-possessed nouns in the constructions discussed in section 2.2.1, this agreement must be specified in a lexibase grammar by assigning contextual inflectional features to sa and e which require that the associated nominal possessor not violate certain features of person and number.

The elements of sentence 5496, type (d) above, must have at least the following feature specifications:

5496	mafa	egu	iana	maranatu
56b	$\left( \begin{array}{l} -\text{plur} \\ +\text{spkr} \\ -\text{addr} \end{array} \right)$	$\left[ \begin{array}{l} -\text{plur} \\ -\text{spkr} \\ -\text{addr} \\ -[+\text{plur}] \\ -[-\text{spkr}] \\ -[+\text{addr}] \end{array} \right]$	$\left( \begin{array}{l} -\text{plur} \\ -\text{spkr} \\ -\text{addr} \end{array} \right)$	$\left( \begin{array}{l} -\text{plur} \\ -\text{spkr} \\ -\text{addr} \end{array} \right)$
	<i>I</i>		<i>fish</i>	<i>kind of fish</i>
		<i>my thing</i>		

*my fish is the maranatu*

(This is an equational sentence of the form NP<sup>1</sup> equals NP<sup>2</sup>, that is, NP<sup>1</sup> (*my fish*) is NP<sup>2</sup> (*maranatu*)).

The features of these lexical items, as stated here, together with the sister-head hypothesis, would require that possessive constructions of this type have the constituent structure shown in structure (T4).

The contextual features of *egu* prevent all nouns that do not carry features indicating first person singular from occurring as its sister constituent. Notice that structure (T5), where *egu* is the head of the construction, is excluded by the contextual features of *egu* as the features are stated above.

This structure is ruled out because *iana*'s feature [-spkr] conflicts with *egu*'s contextual feature [-[-spkr]]. Notice that this conflict cannot be remedied by making the contextual features of the sa/e element directional, since as shown in section 2.2.1.2, the inflectional features of suffix-possessed nouns must be able to refer to attributes in both directions.

The proposal that *egu* cannot be the head of the construction runs counter to the above stated observation that the sa/e element is the only obligatory element of the construction type. It is usually the case that the obligatory element in a construction is the head. In this case, however, lexibase's claims about the nature of grammatical relations (the sister-head hypothesis) and the mechanisms used to specify agreement, require that the sa/e element not be the construction head.

There is a way to reconcile this conflict by making use of two case marking devices which are also required in other construction types. First, the hypothesis that sa and e are suffix-possessed nouns must be accepted. Accepting this hypothesis and the observation that the sa/e element should be the head of alienable possessive constructions, it can be seen that the nominal possessor (*mafa*) and the possessed noun (*iana*) stand in different relationships to the head of the construction (*e*).

(T4)

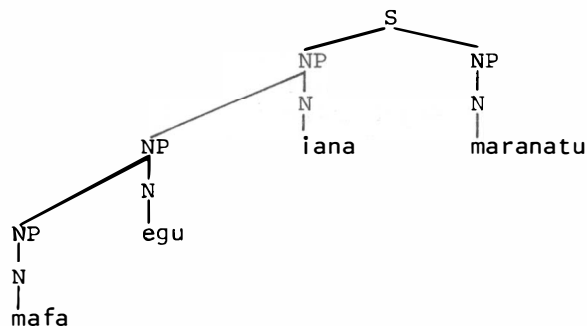

(T5)

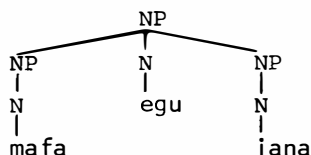

In the suffix-possessive (inalienable) constructions, the possessor stands in a relationship of association to the construction head, the suffix-possessed noun, and therefore carries the case relation feature [+COR] (Correspondent). Likewise in the alienable constructions, the possessor (here, *mafa*) stands in a relationship of association to its construction head, *e*. Here too, the nominal possessor carries the case relation feature [+COR]. Given this case relation feature, agreement between the nominal possessor and the suffix-possessed noun (in this case *e*) can be stated as agreement with an attribute in the Correspondent case relation.

The possessed noun in an alienable construction (here, *iana*) can be analysed as standing in an appositive or equational relationship to the head noun, *e*. This equational relationship is indicated by assigning the case relation feature [+PAT] (Patient) to the possessed noun.

If the relationship between *egū* and *iana* is analysed as an appositive relationship, an appropriate gloss would be *my thing, a fish, or my thing (which is) a fish*. This approach is analogous to the observation made above in section 2.2.1.1 which suggested that some inalienable possessive constructions of type (c) can be appropriately analysed as appositives. In both of these constructions, and other clear cases of appositives (see section 3.3), the nominal attribute is to the right of the head noun. The appositives in section 3.3 also carry the case relation feature [+PAT].

With this analysis of alienable possessive constructions, the features assigned to the constituents of the possessive construction in sentence 5496 can be revised as shown in structure (T6).

Structure (T6) involves no conflicts in feature specifications, and allows the *sa/e* element to be the head of the construction.

Sentence 6072 (structure T7), in which the possessed noun is not present, also provides evidence that *e* and *sa* must be marked for features of plurality and person, like all other nouns.

(T6)

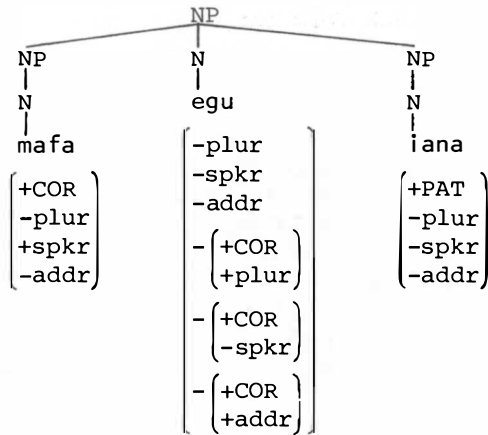

(T7) 6072

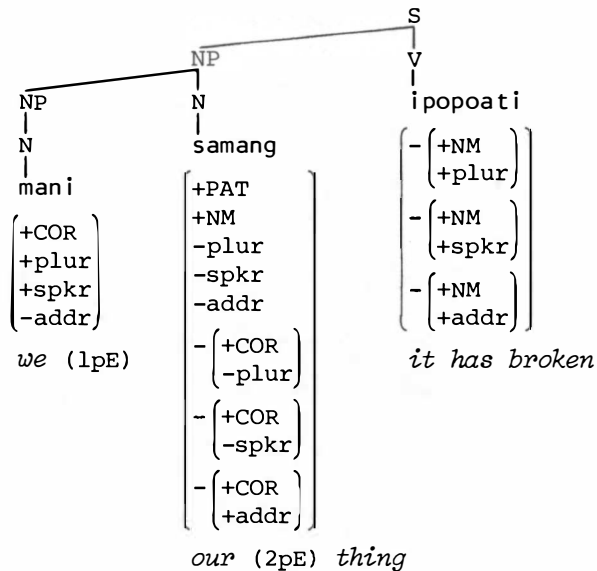

The inflectional features of popoati require that its nominative sister constituent be third person and non-plural. If sa were not marked [-plur, -spkr, -addr], then it would be possible for popoati to have non-third person singular inflectional features, and therefore a non-third person singular prefix. These points argue in favour of placing sa and e in the grammatical category of nouns.

#### 2.2.2.4 Inventory of alienably possessed nouns

This inventory is not intended to suggest that the nouns in each list occur exclusively in one type of possessive construction. In fact, a few words appear in both lists. There is a tendency, however, for nouns of certain general categories to occur in one list as opposed to the other. The inventory

has been made in order to make the forms more readily accessible for use in a study of the different constructions each form can occur in, and the associated differences in meaning.

#### 2.2.2.4.1 sa-possessed nouns

aanana	<i>slave, child</i>	malei	<i>opossum</i>
areai	<i>words, speech</i>	matana	<i>door (cf. eye)</i>
atele	<i>water, river, pool</i>	mauto	<i>kind of basket</i>
au	<i>tree</i>	mea	<i>hole</i>
auau	<i>dog</i>	nitu	<i>ghost</i>
aulu	<i>bamboo</i>	numa	<i>house</i>
baba	<i>hole</i>	ogi	<i>carving, cutting, place where cutting was made</i>
batafa	<i>wife</i>	oko	<i>drum</i>
beampeu	<i>thing, good(s)</i>	pakusi	<i>axe</i>
boala	<i>bow (and arrow)</i>	poa	<i>pit</i>
boi	<i>day, 24 hour interval</i>	rarami	<i>food</i>
boo	<i>pig</i>	saiga	<i>garden</i>
efu	<i>pipes, panpipes</i>	sali	<i>word</i>
ela	<i>music</i>	sansasau-ang	<i>place for washing things</i>
famata	<i>village</i>	sape	<i>bed</i>
fanua	<i>fellow clansman</i>	siburi	<i>conch shell</i>
fatei	<i>interval, period of time</i>	sorau	<i>fishing net</i>
feli	<i>fire</i>	suele	<i>sleep</i>
iana	<i>fish</i>	tala	<i>men, people as subjects of a chief</i>
kalofu	<i>village meeting house</i>	talaiba	<i>wives (plural of batafa)</i>
kanega	<i>husband</i>	tataru	<i>custom, work, business</i>
karo	<i>parrot</i>	toloo	<i>eel</i>
kiniu	<i>canoe</i>	toniga	<i>slave</i>
kufi	<i>cave</i>	totogolo	<i>walking stick</i>
kuisa	<i>basket</i>		
lalaafa	<i>chief</i>		
leao	<i>bark of kalola tree</i>		
magota	<i>wife, old woman</i>		

#### 2.2.2.4.2 e-possessed nouns

atele	<i>river, water, pool</i>	niga	<i>betel-nut, betel-palm</i>
boo	<i>pig</i>	niunu	<i>coconut</i>
buoto	<i>a kind of fish</i>	onsala	<i>a kind of tree</i>
famata	<i>village</i>	rarami	<i>food</i>
gurikai	<i>tree rat</i>	sanaka	<i>flesh or fish food</i>
iana	<i>fish</i>	tamari	<i>food for journey</i>
kai	<i>canary nut</i>	toloo	<i>fresh water eel</i>
kokong	<i>taro</i>	tungkesia	<i>a kind of taro</i>
malei	<i>opossum</i>		

### 2.2.2.5 Other types of alienable possessive constructions

The great majority of *sa/e* possessive constructions fit into the N[pssr] *sa/e-sfx* (N[pssd]) pattern described above (types d-g). There are some other less extensively represented types, however, which do not fit into this general pattern. These will be described in this section.

#### 2.2.2.5.1 Alienable constructions with locative *ang*

The most conspicuous and best represented of these variant constructions is one which makes use of the locative postposition *ang* in association with the possessed noun.

For example:

383	re-rerega	sa-na	famata	ang	Tupariti
4a	3p:nfut- <i>ready</i>	thing-3s:pssv	village	loc	Tupariti
	<i>they got ready to go to Tupariti's village</i>				
475	re-soku	sa-na	famata	ang	Arentesi
5a	3p:nfut- <i>arrive</i>	thing-3s:pssv	village	loc	Arentesi
	<i>they came to Arentesi's place</i>				

Rather than the expected N[pssr] *sa-sfx* N[pssd], in these sentences we find *sa-sfx* N[pssd] *ang* N[pssr].

This type of construction, which is fairly well represented in the texts (21 sentences), presents a rather serious problem for the lexicase analysis proposed above. Since *ang* is a postposition, sentences 383 and 475 have constituent structures as shown in structure (T8).

(T8)

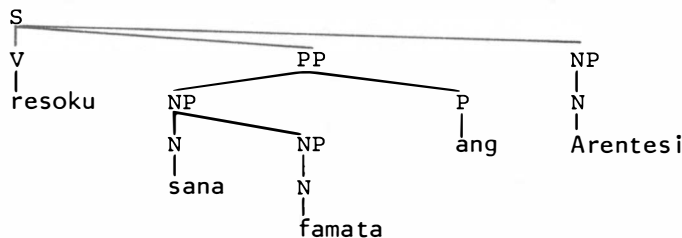

This structure does not place the nominal possessor, *Arentesi*, as an attribute of the possessed noun, as it would be in the constructions described in 1.2.2.2, and as it must be if it is syntactically related to the possessed noun.

A sentence with the same meaning as 475 does occur, however, with the expected word order:

527	re-soku	Arentesi	sa-na	famata	ang
5d	3p:nfut- <i>arrive</i>	Arentesi	thing-3s:pssv	village	loc
	<i>they reached Arentesi's place</i>				

This sentence has a more appropriate constituent structure, as shown in structure (T9).

(T9)

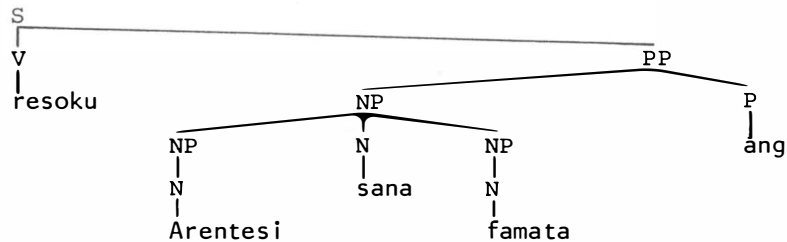

The word order illustrated by sentences 383 and 475 is also found in five sentences in which the locative *ang* does not occur in association with the possessed noun:

4651	sa-na	batafa	Drimoai	i-meka-sofa
47b	<i>thing-3s:pssv</i>	<i>woman</i>	<i>Drimoai</i>	<i>3s:nfut-until:tired-wait</i>
	<i>Drimoai's wife waited for him till she was tired</i>			

Though the gloss does not suggest it, this sentence could also have the meaning *his wife waited for Drimoai*, which would account for the variant word order.

There appears to be no satisfactory way to fit sentences with this variant word order into the analysis presented above. Rather than view these constructions as a contradiction to the analysis, however, it may be possible to explain the postposed possessor as an 'after-thought' on the part of the speaker. *sana batafa* in 4651 could be analysed as a type (f) construction with *Drimoai* added as an after-thought to clarify the referent of the possessive. This possible explanation can only be regarded as speculation at this stage of the investigation, however.

Though this construction is less common in Mono-Alu than the related type (d), it is identical to the construction Pawley has tentatively reconstructed for POC (see section 2.1.2.3).

#### 2.2.2.5.2 *ena* as an instrumental preposition

A word identical in form to the third person singular possessive *ena* occurs in 14 sentences with the meaning *with* (instrumental).

Examples:

5314	iri-lafa-i	ena	mua
52m	<i>3p:nfut-hit-tr</i>	<i>with</i>	<i>club</i>
	<i>they beat him with clubs</i>		
5758	ena	too-mang	ami-bage
60d	<i>with</i>	<i>head-lpE:pssv</i>	<i>lpE:shuck</i>
	<i>we took out the fish from the shell with our heads</i>		

It seems most reasonable to treat this form as a preposition distinct from the possessive *ena*.

## 2.2.2.5.3 Other variant constructions

(a) Sentence 5323 exhibits an unusual, but perhaps explainable, word order:

5323    ela            efu            talaiva    sa-ria  
53a     *song/music panpipes women thing-3p:pssv*  
          *women's music was the panpipes*

This sentence can be analysed as an equational sentence, in which case the word order is as expected. Analysed as an equational sentence, 5323 would have the constituent structure shown in (T10).

(T10)

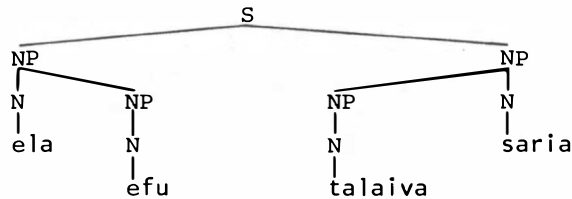

The first noun phrase consists of the head noun *ela* with a nominal attribute *efu*, *panpipe music*. The second is a type (e) construction, *the women's thing*. A more accurate literal translation would be *panpipe music was the women's thing*.

(b) The possessed noun in sentence 5705 is in an unusual position, completely separated from the possessive.

5705    ukala            ami-lapu        e-ra  
60b     *kind:of:fish lpE:nfut-kill thing-lpI:pssv*  
          *we have caught ukala (fish) for us*

*ukala* may occur initially as a topic for emphasis. Notice that the verb prefix is exclusive, while the possessive is inclusive. Thus the translation should probably be *we (excluding you) caught fish for all of us (you included)*.

(c) Three sentences contain possessive constructions in which it is not clear whether the nominal elements are part of a possessive construction, or some other sentence constituent. For example:

1199    re-fa-popoa            ga oko, sa-na            oko kanega  
9m     3p:nfut-caus-sound   abs drum, thing-3s:pssv drum old:man  
  
          sa-na            kalofa            a  
          *thing-3s:pssv meeting:house loc*  
          *they beat the drum, the old man's drum in his meeting house*

*kanega* could be associated either with *sana oko* or *sana kalofa*. In the first case the construction would be the less common type discussed in section 2.2.2.5.1. In the second case, the word order is as expected for the usual type (d) construction.

1241    kanega    sa-na            famata    ang    talaiva    elua  
9q     *old:man thing-3s:pssv village loc women two*  
  
          ma-mamaifa            i-fun-i-ri  
          *pl-chiefly:women 3s:nfut-hide-tr-3p*  
          *the old man has hidden two women, women of chiefly rank,*  
          *in his place*

kanega could either be the subject of the sentence, as suggested by the gloss, or the possessor with respect to famata. In either case the word order is as would be expected.

(d) The translations of a few sentences containing possessive constructions are very obscure, mainly due to the fact that Wheeler is not sure of the meanings of several of the words involved. The word order of most of these sentences differs from the expected word order.



## CHAPTER 3

### MODIFIERS: ATTRIBUTES OF NOUNS

#### 3. INTRODUCTION

This section is concerned with words and more complex constituents which function as attributes of nouns. These attributes include (a) determiners, (b) appositive constructions, (c) relative clauses (sentential attributes), and (d) another set of modifiers which will provisionally be categorised as nouns.

The analysis of determiners is at best extremely tentative, and should be viewed as little more than an inventory of forms which frequently precede nouns, and a discussion of their distribution with respect to other sentence elements. The decision to categorise these forms as determiners is based on their association with nouns, and glosses provided by Wheeler. It appears that some of these forms also function as demonstrative pronouns. Certain difficulties which have contributed to the tentative nature of this segment of the analysis will be mentioned in section 3.1.1.

The analysis of modifiers in section 3.1.2 begins by recognising two classes of modifiers which can be distinguished on the basis of their morphological properties. All members of one class end in *na*, and there is strong evidence that a morpheme boundary separates *na* from the rest of the form.

By examining their morphological and syntactic properties, section 3.2 attempts to determine the grammatical status of these modifiers. Both of these properties point to the conclusion that these forms are nouns rather than adjectives. Syntactic evidence which argues in favour of this conclusion is that these forms occur in a variety of environments where nouns would be expected: (1) as head nouns, (2) in the position of nouns in possessive constructions, (3) in the position of nouns in locative constructions, (4) in the position of head nouns with attributes which are frequently found as attributes of nouns, and (5) preceded by determiners. The fact that some of these forms occur with possessive suffixes is also evidence in favour of the proposal that they are nouns.

The appositive constructions discussed in section 3.3 consist simply of a noun or noun phrase which functions as an attribute of a head noun. The relationship between the head noun and attribute is assumed to be an equational relationship. In appositive constructions, however, the equivalence is presupposed rather than asserted, as would be the case in an equational sentence.

The discussion of relative clauses in section 3.4 considers three alternative analyses of the relative clause marker *ang*. On the basis of its distribution with respect to other sentence constituents it is concluded that *ang* functions syntactically as a nominal element and therefore that it would be most accurate to analyse it as a relative pronoun rather than a conjunction or prepositional ligature.

### 3.1 Distribution of modifiers

#### 3.1.1 Determiners

Five Mono-Alu forms (and their variants) appear to function as determiners and demonstrative or indefinite third person pronouns. It is difficult to determine the semantic function of these forms on the basis of Wheeler's texts alone, since it is often the case that a noun marked by a determiner and one that is not marked by a determiner have identical translations. Thus it will not be possible to ascertain the precise syntactic and semantic characteristics of these forms without additional data. It has been possible, however, to determine the distribution of the forms, and some general characteristics of their function. Because they are associated with nouns and are glossed by English determiners, these forms have been provisionally analysed as determiners.

*ea* (alternate forms: *eaang*, *eam*, *eang*). According to Wheeler's glosses, these forms appear to function as determiners (often as indefinite articles) and also as demonstrative pronouns. As determiners, they occur immediately preceding a head noun. It appears from the translations to the texts that they do not indicate a distinction with respect to either proximity or plurality, as the following examples indicate.

*ea* as a definite article:

singular

1673    *ea*    *tióng*    *i-lefe*                    *ma*            *famata*    *ang*  
 14f     det   *man*    3s:nfut-return    *hither*    *village*    loc  
           *the man came back to the village*

plural

287     *ea*     *aanana*    *au*            *sa-ria*                    *famata*    *ang*  
 3e     det   *children*   *stay/be*   *thing-3p:pssv*   *village*    loc  
           *the children stayed in the village*  
           (*the children's staying in the village*)

*ea* as a demonstrative determiner:

singular

1461    *ea*    *boo*    *mafa*    *nka-gu*  
 12b     det   *pig*    *ls*        *mother-ls:pssv*  
           *this pig is my mother*

singular

4576    *ea*    *kopi*                    *au*            *e-na*                    *atele*    *a*  
 46f     det   *kind:of:bird*   *stay/be*   *thing-3s:pssv*   *river*    loc  
           *that kopi (bird) was by a river*

plural

490 ea talaiva, sa-na talaiva,  
 5b det *women* *thing-3s:pssv* *women*  
 re-sali-male-m ga tete-ria  
 3p:nfut-speak-again-tr abs *grandmother-3p:pssv*  
*those women, his wives, again spoke to their grandmother*

ea as a demonstrative pronoun:

singular

2109 mafa sa-gu numa ea  
 16r ls *thing-ls:pssv* *house* dem:pron  
*this is my house*  
 723 ea ga rekona  
 7d dem:pron *good*  
*that is good*

(No examples of ea, or its variants, as a plural demonstrative pronoun can be found in Wheeler's texts.)

The forms also occur with proper nouns:

ea:

2177 ea Busoi re-i-ng  
 17f det *Busoi* 3p:nfut-say-tr  
*said they to Busoi*

eam:

6785 eam Bunosi i-ue  
 67z det *Bunosi* 3s:nfut-run:away/disappear  
*Bunosi vanished*

eaang:

5133 eaang Kikoau i-ue  
 51b det *Kikoau* 3s:nfut-run:away/disappear  
*Kikoau had gone off*

Sentences 610 and 6747 suggest that ea and its variants may also function as general third person pronouns.

610 ea nitu ga  
 6c 3s *ghost*  
*it is a ghost*  
 6747 eang paitena tiom  
 67x 3s *bad/evil man*  
*he is an evil man*

Two forms which occur very rarely in the texts are rea and reang. Wheeler says these are the plural forms of ea and eaang. They do occur only with plural nouns, but as the above examples show, ea and its variants are not restricted to occurrence with singular nouns. If the initial r of rea and reang carries the meaning 'plural' it is possible that it is related to the r of re and iri, third person plural verb prefixes, in contrast to the third person singular prefix i.

ena (alternate forms enaam, enaang). The distribution and meaning of these forms appear to be similar to those of ea and its variants, with the exception that in this sample enaa does not occur with plural nouns. enaa and its variants are not as well represented in the texts as ea and its variants.

ena as a demonstrative determiner:

- 4776      enaam    peu      pipilua    paitena  
 48g      det      *thing corpse bad*  
           *this thing, a dead body, is not good*
- 937      enaa    atele    ona-roro-i ...  
 8h      det      *river 2s:fut-see-tr*  
           *if you see that (the) river ...*

ena as a demonstrative pronoun:

- 6375      enaa      ga    tanutanu  
 66x      dem:pron      *maker*  
           *is that one a maker?*

ena with proper nouns:

- 6380      enaang    Bego    abu    tanutanu  
 66x      det      *Bego neg maker*  
           *that Bego is not a maker*

oang occurs only three times in the texts, always translated as a demonstrative pronoun:

- 2941      e-gu                      onsala                      oang  
 26b      *thing-1s:pssv kind:of:tree dem:pron*  
           *that is my onsala tree*

Wheeler's glossary also has an entry for oa, though it does not occur in the texts.

With access only to the data in Wheeler's texts, it has not been possible to ascertain the syntactic or semantic importance of the alternation between presence and absence of the final nasals in these forms. The alternation between final ng and m can in some cases, however, be explained by assimilation to the initial consonant of the following word.

elea (variant forms eleam, eleaang). The Mono-Alu word meaning *one*, elea, appears to have three different functions. As a modifier meaning *one* it generally occurs to the right of its head noun. This function of elea will be discussed more fully in section 3.1.2.2. As indicated by Wheeler's glosses, the form also functions as an indefinite article. In its function as an article it usually occurs to the left of its head noun, as do the other determiners discussed above (ea, enaa). The third function of elea is as a third person pronoun, usually translated as *one*. This independent nominal function of elea is discussed in section 3.2.

elea as an indefinite article:

- 2095      iri-bilu-i                      ga    elea    famata  
 16p      3p:nfut-go:on-tr    abs    det      *village*  
           *they left a village behind them*
- 2691      i-ki                                      ga    elea    box  
 21p      3s:nfut-open:with:key    abs    det      *box*  
           *he opened a box*

elea as a third person pronoun:

692	elea	i-lapu		
7c	3s	3s:nfut-kill		
		<i>he killed one</i>		
5182	iri-roro-i-male	ga	elea	
52b	3p:nfut-see-tr-again	abs	3s	
		<i>they saw another one</i>		
		<i>(they again saw one)</i>		

Unlike the variant forms of ea and enaa, the distribution of elea's word final nasal variants suggests an explanation for the alternation. All the examples of eleaang and eleam are associated with locations. This suggests that the final sequence ang or am may be the locative postposition which frequently takes both of these forms. For example:

1188	re-soku	elea	ang	famata
91	3p:nfut-arrive	det	loc	<i>village</i>
		<i>they came to a village</i>		

While this should not be viewed as a conclusive explanation without further testing, it is consistent with the available data. It should also be noted that elea can occur without ang, but with a locative noun. In this case, however, the locative noun itself occurs with the locative postposition, as shown in sentence 4713.

4713	i-soku	elea	famata	ang
48c	3s:nfut-arrive	det	<i>village</i>	loc
		<i>he came to a village</i>		

This explanation is not applicable to the final nasal variants of ea and enaa since they occur with a variety of forms which could not be interpreted as locations.

### 3.1.2 Modifiers

The majority of constructions which contain a noun and a modifying attribute (other than a determiner) consist of the head noun followed by its modifier (N MOD). In a few sentences, however, the order is reversed; the modifier precedes the noun (MOD N).

Based on morphological characteristics, two categories of modifiers can be recognised: (1) those which end in na, and (2) those that do not.

#### 3.1.2.1 Modifiers with word-final na

This group of modifiers can be distinguished from others by the fact that they all end in na, and that there is evidence that there is a morpheme boundary between na and the rest of the form.

The existence of a morpheme boundary is substantiated by the following:

kanega	husband
kanega-na	big
osompeu-na	all of it
osompeu-ria	all (of it)
paite-na	bad
i-paite	he got angry, sick
reko-na	good
fai-reko-i	I did well to him, I treated him well
sale-na	alive
i-sale	he lives, he came to life
tapoi-na	many, much
i-tapoi	it became plentiful, abundant
tibo-na	alone, by himself
tibo-gu	alone, by myself
reapa	long
reapa-na-ang	distant place
taginai	near
taginai-na-ang	place near
ta-posa	broken
i-posa	he broke it
fatutu	fat
fatutu-na	fat

Other modifiers to be discussed in the next section also end in na. However, there is no evidence which indicates that na may be a separate morpheme in those forms.

A few forms in this class can be found in the less common construction type, where the modifier precedes the head noun. In the examples which follow, a sentence for each member of this class is given, showing the more common word order. An additional example is provided for those which occur in constructions with the less common word order.

Examples:

kanegana *big*

2593	tara-aro	ga	au	kanegana
21g	lpI:fut-fell:tree	abs	tree	big
	<i>let us cut down the great tree</i>			
5762	i-roro-i	kanegana	posa	
60d	3s:nfut-see-tr	big	clam	
	<i>he saw a very great clam</i>			

osompeuna *all*

5189	oge kai	isa-ng	ga-ina	iana	osompeuna
52b	oh! brother	throw-tr		fish	all
	<i>oh!, brother, throw away all those fish</i>				
	(gaina: combination of ga and ena)				

paitena *angry, sick, no good, bad, evil*

1138	mafa	magota	paitena
9f	1s	old:woman	bad
	<i>I am a useless old woman</i>		

1141 mafa paitena magota  
 9f 1s *bad old:woman*  
*I am a useless old woman*

rekona *good*

2377 batafa rekona ena-roro-i nitu lau ena-tiong  
 19a woman good 3s:fut-see-tr ghost then 3s:fut-man  
*if the ghost sees a comely woman, then it becomes a man*

salena *alive, living*

2289 ea batafa salena i-fuane  
 18b det woman alive 3s:nfut-put:in:basket  
 kokobui a ga iana  
*kind:of:basket loc abs fish*  
*the living woman put the fish in a kokobui basket*

tapoina *many, much*

5890 eang Dudueri rarami tapoina i-fa-mako  
 64b det Dudueri food much 3s:nfut-caus-cook  
*Dudueri had a lot of food cooked*

3781 batafa i-tele ga nife tapoina rarami  
 37d woman 3s:nfut-give abs snake much food  
*the woman gave the snake plenty of food*

tibona *alone, self*

1263 i-safili ga lalaafa tibona  
 9s 3s:nfut-come:out abs chief alone  
*the chief went forward by himself*

Two other forms (reapa *long*, taginai *near*) occur in this type of construction without final na. In some locative constructions, however, they occur with final na. These will be discussed below in section 3.2.2.3.

reapa *long (distance or dimension)*

2603 ropu reapa ing-fa-ulul-i ama tiga abu  
 21h rope long 3p:nfut-caus-hang-tr hither from sky  
*they lowered a long rope from the sky*

taginai *near*

1271 peu ga famata taginai  
 9s ? village near  
*they are near the village*  
 (in this context, peu has something to do with being in existence in a location)

Three other forms, fatutuna *fat*, taposana *broken*, and totona *straight, true* may also belong to this morphologically defined class of modifier. Though these forms do not occur as modifiers of nouns in Wheeler's texts, they do occur in other construction types in which members of this class also occur. The fact that they share morphological characteristics and their distributions partially coincide suggests that they are likely to be members of the same syntactic class as the forms listed above.

## 3.1.2.2 Other modifiers

All of the following forms, except those which contain *aiina* and *eetana* always occur in the more common construction type, where the modifier follows the head noun.

*aabau some*

- 6298 i-fauka-i-male-ri ga aanana aabau Roai  
 66m 3s:nfut-meet-tr-again-3p abs children some Roai  
*he met some more children at Roai*

*aiina small amount of something*

- 3794 i-tele-ri boo aiina  
 37e 3s:nfut-give-3p pig small:amount  
*she gave them a little pig's flesh*
- 1094 ena-tele-afa aiina rarami  
 9d 3s:fut-give-1s small:amount food  
*let her give me a little food*

*ai-aiina small in size*

- 3086 maang fanua emia-sumee au aiaina  
 29b 2p men 2p:fut-lift tree small  
*you men lift up small trees*

*atu-aiina small in size*

- 1718 iri-roro-i ga toloo atuaiina  
 15a 3p:nfut-see-tr abs eel small  
*they saw a small eel*

*eetana raw*

- 155 i-aang ga kokong eetana saiga ang  
 2a 3s:nfut-eat abs taro raw garden loc  
*she ate raw taro in the garden*
- 1111 i-galo ga eetana kokong, kokong lea-na tungkesia  
 9e 3s:nfut-carry abs raw taro taro name-3s:pssv tungkesia  
*she took away raw taro, the taro called tungkesia*

*fama first, eldest*

- 1154 i-ulo fama  
 9g 3s:nfut-redden:hair:with:red:earth first  
 ga fabiu-na fama  
 abs grandchild-3s:pssv eldest  
*she first reddened her eldest granddaughter's head*

*famuri youngest*

- 1156 i-ulo-male ga fabiu-na famuri  
 9g 3s:nfut-redden-again abs grandchild-3s:pssv youngest  
*she then reddened the younger granddaughter's*

*kairikina small*

- 3139 Pakomani kairikina i-kokope  
 29f Pakomani small 3s:nfut-hide  
*little Pakomani had hidden*



loai *wild, not domesticated*

- 3360 i-lapu ga boo loai  
 34b 3s:nfut-kill abs pig wild  
*he killed a wild pig*

lugita *thin, skinny*

- 1982 boo paitena lugita  
 16g pig bad thin  
*the pigs are bad ones and thin*

manuale *male, man*

- 3055 i-poro ga natu-na. natu-na manuale  
 29a 3s:nfut-be:born abs child-3s:pssv child-3s:pssv male  
*her child was born. A man child*

masimasini *red (masini blood)*

- 4728 i-roro-i ga atele masimasini  
 48d 3s:nfut-see-tr abs water red  
*he saw a piece of red water*

opu *only*

- 1083 mamaifa e-na kokong  
 9c chiefly:woman thing-3s:pssv taro  
 tungkesia opu i-bana  
*kind:of:taro only 3s:nfut-put:away*  
*the mamaifa put away her taro, tungkesia, only*

solo *only*

- 3795 iafaua ga boo aiina solo  
 37e why abs pig little only  
*why is there only a little pig's flesh?*

Notice that solo modifies aiina *small amount* which itself modifies the head noun boo. It may be the case that solo is not a member of this class of modifiers since it occurs only as a modifier of aiina and lualua *small amount*, both of which are themselves modifiers. solo may be a member of a class of modifiers which have syntactic properties different from the other forms listed here.

The distribution of quantifiers is the same as that of these modifiers. The quantifiers, however, occur frequently in the less common construction type.

elea *one*

- 5173 iri-soot-i ga iana elea  
 52a 3p:nfut-shoot-tr abs fish one  
*they shot a fish*  
 4701 i-soku elea famata ang  
 48b 3s:nfut-arrive one village loc  
*he came to one village*

When it occurs to the left of the noun, this form may function as a determiner, as discussed in section 3.1.1.

elua *two*

4986 i-i-n-ri ga na-natu-na elua  
 50a 3s:nfut-say-tr-3p abs pl-child-3s:pssv two  
*she said to her two children*

episa *three*

373 boi episa emia-lau ma sa-gu famata ang  
 4a day three 2p:fut-come hither thing-1s:pssv village loc  
*in three days come to my place*

5565 episa boi iri-porau  
 57b three day 3p:nfut-name/fix  
*they fixed an interval of three days*

efati *four*

4225 re-noboto tala efati latu  
 41t 3p:nfut-distribute men four hundred  
*the men distributed four hundred among themselves*

lafulu *ten*

1949 maang boo lafulu emia-gagana emia-galo-ri ma  
 16e 2s pig ten 2p:fut-go 2p:fut-carry-3p hither  
*do ye go and bring back ten pigs*

1946 i-lapu ga lafulu boo  
 16e 3s:nfut-kill abs ten pig  
*he killed ten pigs*

The meanings of several other forms suggest that they probably also function as modifiers, although they do not occur as modifiers of nouns in Wheeler's texts. They do, however, occur in constructions in which the modifiers discussed here also occur. These forms are: *anaa white (of pig)* (from *anaa white cockatoo*), *lima five*, *lualua little, small amount*, *olatu forbidden, taboo*, *osom/osong all*.

## 3.1.2.3 Nominal modifiers

Nouns sometimes occur as modifiers of other nouns. In these constructions, the modifier can be analysed as a nominal attribute of the head noun. The noun phrases *natuna batafa*, and *ela efu* in the sentences below can be analysed in this way.

5323 ela efu talaiva sa-ria  
 53a music panpipe women thing-3p:pssv  
*women's music was the panpipe  
 (panpipe music was the women's thing)*

5545 i-fa-por-i ga batafa natuna batafa  
 57a 3s:nfut-caus-bring:forth-tr abs woman child woman  
*she brought forth a girl, a girl child*

These noun phrases have the structure shown in (T11) below.

(T11)

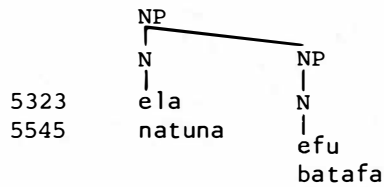

These phrases can be glossed: *panpipe music* and *woman (female) child*.

### 3.2 The grammatical status of modifiers

#### 3.2.0 Objectives

The objective of this section is to look at certain morphological and syntactic characteristics of the modifiers presented in sections 3.1.2.1 and 3.1.2.2 in order to determine what grammatical category they belong to. My conclusion will be (1) that these forms function syntactically as nouns and (2) that since they function syntactically as nouns their constituent structures should be of the same form as those discussed in section 3.1.2.3, where the modifying attributes are clearly nouns.

#### 3.2.1 Morphological properties

In the footnotes to some of his texts, Wheeler says that the final *na* of the modifiers discussed in section 3.1.2.1 is the third person singular possessive suffix (for example see 16d2, p.272; 65r2, p.328). This possibility is supported by the fact that two of those forms (*osompeu* and *tibo*) also occur with suffixes other than third person singular:

*tibo alone, self*

4755	mafa	tibo-gu	fana-sisile	
48e	1s	<i>self</i> -1s:pssv	1s:fut-bathe	
		<i>I will wash alone</i>		
214	maito	tibo-ng	oi-aang	ga kokong
2f	2s	<i>self</i> -2s:pssv	2s:nfut-eat	abs taro
		<i>thou thyself didst eat the taro</i>		
3431	tibo-mia	am-mera	ga lalaafa	sa-na batafa
34g	<i>self</i> -2p:pssv	2p:nfut-take	abs chief	<i>thing</i> -3s:pssv woman
		<i>it was you that took the chief's wife with you</i>		

*osompeu all*

6110	aisa	tapoina	osompeu-ra	tara-gafulu
65r	<i>come:on</i>	<i>many</i>	<i>all</i> -lpI:pssv	lpI:fut-finish
	<i>come on! if we all of us go</i>			
	<i>(come on! let's all be finished (going))</i>			
6111	re-usu	osompeu-ria		
65r	3p:nfut-swim	<i>all</i> -3p:pssv		
	<i>they all swam off</i>			

These suffixes suggest that at least these two forms are suffix-possessed nouns. If this is the case, then these forms will have all of the inflectional features of the suffix-possessed nouns discussed in section 2.2.1 and will behave syntactically like all other suffix-possessed nouns. This means that *tibo* and *osompeu* (and perhaps the other final *na* modifiers as well) would have to be construction heads, rather than attributes of head nouns as has been assumed up to this point.

This is consistent with the section 2.2.1 analysis of suffix-possessed nouns, since the most common order of constituents in a suffix-possessive construction (N[pssr] N[pssd]) is the same as the most common order of constituents in the constructions containing modifiers (N MOD). If these modifiers can be correctly analysed as suffix-possessed nouns, then MOD would be the possessed noun (N[pssd]), and head of the construction, and N would be the nominal possessor (N[pssr]), and an attribute of the head noun.

Analysing these forms as possessed nouns, and therefore head nouns, requires that the constructions be seen from a significantly different point of view. Consider, for example, a noun phrase such as:

- (a)        *toloo kanegana*  
           *eel     big*  
           *big eel*

If *kanegana* is viewed as a modifier of *toloo*, then *toloo* is the head of the construction, with the attribute *kanegana*. Such a noun phrase could be glossed *big eel* as above.

If, however, *kanegana* is analysed as a suffix-possessed noun, it will be the head of the construction (as explained in section 2.2.1). *toloo*, then, would be an attribute of *kanegana*, rather than vice versa. A more appropriate gloss for noun phrase (a), taking this approach, would be *bigness of the eel*, or *the eel's bigness*. This approach may not be readily acceptable intuitively, but is syntactically defensible, and is similar in certain respects to George Milner's analysis of the relationship between modified and modifying elements in Basque and Polynesian (Milner 1976:99-101).

The proposal that these forms are possessed nouns must be viewed as a very tentative hypothesis since it is based on limited data. Further study of the syntactic distribution of the forms and an investigation of the extent to which they can take other than third person possessive suffixes will lead to a more reliable conclusion.

It may turn out that the hypothesis that all *na* final modifiers are suffix-possessed nouns is too strong. Even if it is not possible to correctly analyse these forms as suffix-possessed nouns, several characteristics of their syntactic distribution suggest that they are nouns nonetheless.

### 3.2.2 Syntactic properties

The following discussion applies to both classes of modifiers described above (both with and without word final *na*), and argues in favour of the possibility that they are nouns. Though I am suggesting that the modifiers are nouns that occur as syntactic attributes of their head nouns,<sup>5</sup> their syntactic behaviour could be accounted for equally well by assuming that there is a class of nouns that correspond to these forms, and a set of morphologically unmarked adjectives which are derived from the nouns.

However, since other Mono-Alu constructions (notably possessives, chapter 2, and nominal modifiers, section 3.1.2.3) are composed of head nouns modified by nominal attributes, it is not unreasonable to analyse these constructions in a similar fashion. The next six subsections describe several aspects of the syntactic distribution of these forms which support the hypothesis that they are nouns.

### 3.2.2.1 Forms occurring as head nouns

In addition to their function as modifiers, many of the forms listed in sections 3.1.2.1 and 3.1.2.2 (at least 21 out of 37) also occur in isolation from other nouns. That is, they occur as heads of nominal constructions. For example:

*aiaiina small ones, small things*

1888      *aiaiina      tatai      sa-ria*  
 16a      *small:ones weep      thing-3p:pssv*  
          *the puppies (small ones) were whimpering*  
          *(the whimpering of the small ones)*

*eetana raw things, rawness*

2291      *i-golu      eetana*  
 18b      *3s:nfut-eat      raw:things*  
          *he ate them raw*  
          *(he ate raw things, he ate what was raw)*

*paitena bad, evil thing*

749      *ga      ami-golu      uta      ga      paitena*  
 7f      *?      lpE:nfut-eat      ?      abs      bad:thing*  
          *we have eaten what is bad*

*tapoina much, a lot, many*

5460      *tapoina      ga      emia-anee-male*  
 54g      *many      abs      2p:fut-climb-again*  
          *a lot of you go up now*

*aabau some*

5461      *iri-anee-male      ga      aabau*  
 54g      *3p:nfut-climb-again      abs      some*  
          *once more some climbed up*

*episa three*

695      *i-lapu-lapu-ri      ga      episa*  
 7c      *3s:nfut-kill-kill-3p      abs      three*  
          *he killed three*

*kanegana big thing*

2695      *i-ki      ga      kanegana*  
 21q      *3s:nfut-open/unlock      abs      big:thing*  
          *he opened a big one*

lima *five*

6100 aisa lima usu  
 65p come! five swim  
 come! let five swim off

loai *wild thing*

2041 boi tapoina sa-gu tala fana-lapu loai  
 16m day many thing-1s:pssv men 1s:fut-kill wild:thing  
 whenever I kill wild (pigs) for my men  
 (many days I will kill wild ones for my men)

lualua *small amount*

3762 iri-aang ga lualua natu-na ua  
 37c 3p:nfut-eat abs small:amount child-3s:pssv with  
 he and his son had only a little to eat  
 (they ate a little, with his son;  
 they ate a little, he with his son)

taginai *nearby place*

3518 i-soku taginai  
 35e 3s:nfut-arrive nearby:place  
 she came near  
 (she came to a nearby place)

These sentences clearly show that many of the same forms that function as modifiers also function as independent nouns, since they occur in the same syntactic environments as nouns.

## 3.2.2.2 Forms occurring in nominal positions in possessive constructions

Three forms occur in the position usually filled by a nominal possessor in alienable possessive constructions, and one form occurs as the possessed noun in that construction type.

As nominal possessor:

fama *first, eldest*

2724 fama sa-na i-muri-muri-male  
 22b eldest thing-3s:pssv 3s:nfut-behind-behind-again  
 the elder brother's was left behind in turn

famuri *youngest*

2722 i-gagana ga famuri sa-na  
 22b 3s:nfut-go abs youngest thing-3s:pssv  
 the younger's won  
 (the younger's went (ahead))

salena *living one, live one*

5806 maita abu salena e-na rarami tai-an-'nta  
 61b lpI neg living:one thing-3s:pssv food lpI:nfut-eat-?  
 it is not the food of a living man that we have eaten  
 (an'nta from aang-ita)

As possessed noun:

*aiina small amount*

3792      tlong    natu-na              ua      e-ria  
 37e      man      child-3s:pssv    with    thing-2p:pssv  
  
           aiina              ga      i-faio  
           small:amount    abs    3s:nfut-put/set  
           for the man and his son she set only a little  
           (she gave the man and his son their small amount)

The fact that these forms occur in nominal positions in these constructions shows that their syntactic distribution is not distinct from that of nouns.

### 3.2.2.3 Forms occurring in nominal positions in locative constructions

A few of the modifiers occur in locative constructions in positions normally filled by nouns. Both the locative postposition *ang at*, and the preposition *tiga from* occur in sentences of this type.

*kanegana big thing*

2697      au            sa-ria              kanegana    ang    boxa  
 21q      stay/be    thing-3p:pssv    big:thing    loc    box  
           they were in the big box  
           (they were in a big thing which was a box)

*taginaina a nearby place*

4751      i-sooto            taginaina            ang    mamaifa  
 48e      3s:nfut-aim    nearby:place    loc    chiefly:woman  
           he aimed near the chiefly woman  
           (he aimed at a place near the chief's woman)

*reapana a distant place*

6848      Mono    i-soku              reapana              ang  
 70a      Mono    3s:nfut-arrive    distant:place    loc  
           Mono has got a long way off  
           (Mono arrived at a place distant from here)  
  
 1013      i-fa-areai            tiga    reapana  
 8o      3s:nfut-caus-speak    from    distant:place  
           she spoke to her from afar  
           (she spoke to her from a distant place)

Notice that both *taginai* and *reapa* occur as modifiers without final *na*, but as head nouns with final *na*.

### 3.2.2.4 Forms occurring with modifiers of nouns

At least one of the items which functions as a modifier in the constructions described in 3.1.2.1 and 3.1.2.2 is itself modified by a form which also functions as a modifier of a noun. Three other forms may also fit this pattern, but other elements of their constructions make their status uncertain.

salena *living one*

- 5120      iri-galo      salena      aabau  
 51a      3p:nfut-carry *living:one*      some  
*some they brought alive*  
*(they brought some living ones; they brought some that*  
*were alive)*

The status of *aaina* and *lualua* in 3795 and 4716 below is uncertain because these two sentences constitute the only occurrences of the modifier *solo* in the texts. Thus it is not certain that *solo* occurs as a modifier of other nouns. Also in 3795 both *aaina* and *solo* could be modifiers of *boo* rather than *solo* being a modifier of *aaina*.

- 3795      iafaua ga      boo aaina      solo  
 37e      why      abs pig *small:amount*      only  
*why is there only a little pig's flesh?*
- 4716      roro-i-ami lualua      solo  
 48c      see-tr-lpE *small:amount*      only  
*see we are only a few*  
*(see us who are only a few)*

In 1982 below, the grammatical status of *paitena* is uncertain since both *paitena* and *lugita* could be modifiers of *boo*. However, as will be pointed out in Chapter 4 in the discussion of non-verbal stative sentences, this sentence could be analysed as *the pigs are bad thin things*, or *the pigs are bad things which are thin*.

- 1982      boo paitena      lugita  
 16g      pig *bad:thing* *thin:thing*  
*the pigs are bad ones and thin*

## 3.2.2.5 Forms occurring with determiners

Four of these forms occur in the same position with respect to the determiner *ea* as do nouns.

*elua two*

- 6091      ea      elua      usu  
 65p      det *two*      swim  
*let two go swimming*

*lafulu ten*

- 5455      ea      lafulu      emia-anee-male  
 54f      det *ten*      2p:fut-climb-again  
*go up ten more*

*lima five*

- 5449      iri-anee      ga      fanua      ea      lima  
 54f      3p:nfut-climb      abs      men      det      five  
*five men went up*



paitena *bad, evil thing*

- 791     ea   paitena   ga   uli-na  
 7k     det *bad:thing* abs *body-3s:pssv*  
        *this is the body, which is no good*  
        *(this bad thing is a body; this body is a bad thing)*

### 3.2.2.6 Forms occurring as inflected verbs

One final characteristic of the distribution of these forms is that some of them occur as inflected verb stems. Notice that in all but one of the following examples forms that occur as modifiers with word final na occur as verbs without the na.

elua *two*

- 5573     i-elua         boi  
 57c     3s:nfut-two *day*  
        *two days went*  
        *(days became two)*

paite *bad, evil*

- 5023     i-paite-ri         aanana  
 50d     3s:nfut-bad-3p *children*  
        *she got angry with the children*

reko *good*

- 3112     fai-reko-i  
 29d     1s:nfut-good-tr  
        *I have done right to him*

sale *alive, living*

- 6816     i-sale             ga   natu-na  
 67bb     3s:nfut-live abs *child-3s:pssv*  
        *her child came to life*

tapoi *many*

- 3001     i-tapoi             ga   nife  
 28a     3s:nfut-many/plentiful abs *snake*  
        *the snakes were many*  
        *(snakes became plentiful)*
- 5551     rarami i-tapoina  
 57a     *food* 3s:nfut-many/plentiful  
        *there was lots of food*

That these forms function as verb stems is further evidence that their distribution is the same as that of nouns, since many Mono-Alu nouns can function as verb stems. For example:

iana *fish*

- 4373     aabau i-iana  
 43d     *some* 3s:nfut-fish  
        *some of them became fish*

kalola *a kind of tree*

3530 i-kalola  
 35f 3s:nfut-kind:of:tree  
*she became a kalola tree*

lalaafa *chief*

3715 i-lalaafa ga tiong  
 36g 3s:nfut-chief abs man  
*the man became a chief*

toloo *eel*

4348 aabau i-toloo  
 43d some 3s:nfut-eel  
*some became eels*

### 3.2.2.7 Summary

The objective of the foregoing sections has been to describe the distribution of forms which function as modifiers of nouns, and to draw some tentative conclusions concerning their grammatical status. It was pointed out that the syntactic distribution of the modifiers is similar in several ways to the syntactic distribution of nouns. Most importantly, these forms occur in one or more of the following syntactic environments: (1) as heads of noun phrases, (2) in the position of nouns in possessive constructions, (3) in the position of nouns in locative constructions, (4) in the position of head nouns with attributes which are frequently found as attributes of nouns, and (5) with determiners. The fact that some occur with possessive suffixes is also an argument in favour of the proposal that the modifiers are nouns.

Treating these forms as nouns fits in well with the analysis of Mono-Alu nominal constructions as a whole, since there are other constructions (possessives, chapter 2; appositives, section 3.3) which are also composed of head nouns modified by other nouns. Treating these modifiers as nouns also simplifies the analysis of non-verbal stative sentences (see section 4.2), since they can be viewed as equivalent in form to one type of equational sentence (see section 4.1).

In the lexicase formalisation of this analysis to be presented in chapter 6, all modifiers of nouns except determiners and relative clauses are treated as nominal attributes of head nouns.

### 3.3 Appositive constructions

Appositive constructions are abundant in Wheeler's texts. They consist simply of a noun or noun phrase followed by one or more noun phrases. The noun phrase modifiers are interpreted as co-referential to the head noun.

In 2819, the noun *iloana* stands in an appositive relationship to *famuri*:

- 2819 i-polee-male ga famuri  
 22h 3s:nfut-become:pregnant-again abs younger:sister  
 iloa-na  
 co-wife-3s:pssv  
 the younger sister, the fellow wife, got with child too

The appositive can be more complex, consisting of a possessive construction as in 2407 and 5247, or more than one appositive as in 1712.

- 2407 i-ua ga batafa manualai nka-na  
 20b 3s:nfut-say abs woman sea:bird mother-3s:pssv  
 quoth the woman, the sea bird's mother

Here the possessive noun phrase manualai nkana is in apposition to the simple noun batafa.

- 5247 re-neneo ga sa-ria beampeu sa-ria iana  
 52e 3p:nfut-tell abs thing-3p:pssv thing thing-3p:pssv fish  
 they told their property, their fish

In 5247, the possessive construction saria iana is in apposition to another possessive construction saria beampeu.

- 1712 iri-gagana fanua aanana kai-na ua atele a  
 15a 3p:nfut-go people children sibling-3s:pssv with river loc  
 the people, children, two siblings, went to the river  
 (kainaua with his brother refers to two boys who are brothers  
 to one another.)

### 3.4 Relative clauses

The sample of Mono-Alu sentences containing relative clauses is very small; fewer than 20 sentences. Nevertheless, these sentences indicate clearly that there is such a construction in the language, and that it is marked by the morpheme ang (with variant forms an and anta).

It is generally assumed that a relative clause consists of a sentence embedded in a noun phrase and that the embedded sentence acts as a modifier of the head noun of the noun phrase. Mono-Alu's Type I relative clause fits this characterisation.

#### TYPE I:

- 459 i-taofe ga au ang i-aro Tupariti  
 4d 3s:nfut-fall abs tree rel 3s:nfut-cut Tupariti  
 the tree which Tupariti had cut fell
- 1104 i-roro-i ga tungkesia ang  
 9d 3s:nfut-see-tr abs kind:of:taro rel  
 i-bana natu-na  
 3s:nfut-put:away child-3s:pssv  
 she saw the taro which her daughter had put by

2851	i-nkoti	ga	leako	ang	i-tele	
221	3s:nfut-grasp	abs	magic	rel	3s:nfut-give	
	ama	loa-na				
	<i>hither</i>	<i>father-in-law-3s:pssv</i>				
	<i>he took hold of the magic which his father-in-law had given him</i>					
4658	i-ua	ga	nitu	ang	i-mera	Drimoai
47c	3s:nfut-say	abs	ghost	rel	3s:nfut-take	Drimoai
	<i>quoth the ghost who had taken Drimoai with him</i>					

In each of these sentences, *ang* introduces a sentence which carries additional information attributed to the noun immediately preceding *ang*.

Based on this small amount of data it is difficult to accurately determine the syntactic status of the relative marker *ang*. Some possibilities to consider include hypothesising that it is (1) a relative pronoun, as is done in the usual analysis of English relative clauses, (2) a preposition which acts as a 'linker' or 'ligature' between a head noun and a sentence modifier, as proposed in an analysis of proto-Austronesian relative clauses (Pawley, Reid, and Starosta 1978:21-26, also Foley 1976), or (3) a conjunction which simply joins the head noun to its sentential attribute, as suggested by Sohn (1973:358-359) in his analysis of Micronesian relative clauses.

The first alternative involves the assumption that *ang* is a pronoun in the embedded sentence, and is co-referential to the head noun in the higher sentence. Taking this approach, the Type I sentences would have the constituent structure shown in (T12).

This analysis could be supported by showing that *ang* has a pattern of syntactic distribution similar to other pronouns in the language. The Type III constructions which will be discussed below do, in fact, suggest that the syntactic behaviour of *ang* is similar in certain respects to that of a nominal element.

The second and third possible analyses suggest that the relative marker indicates a certain kind of attributive relationship between the head noun and its sentence attribute. No co-reference between the head noun and an element of the embedded sentence is hypothesised explicitly. These analyses would involve hypothesising a structure such as (T13).

(T12)

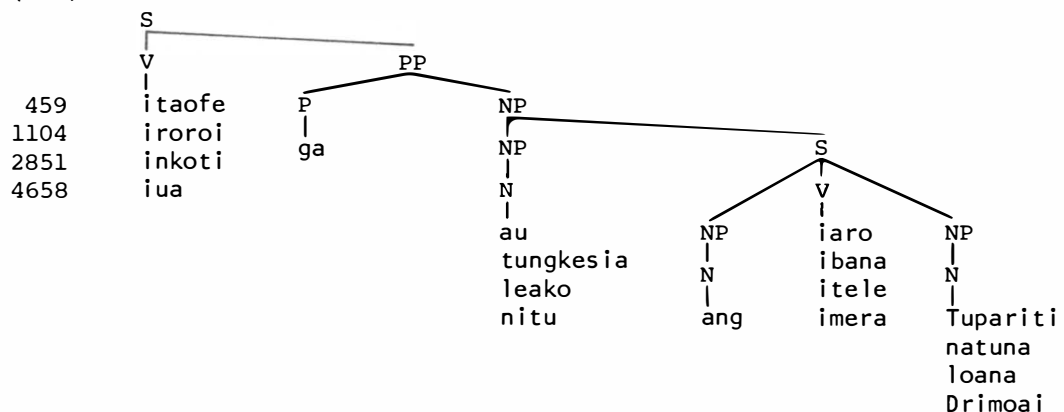

(T13)

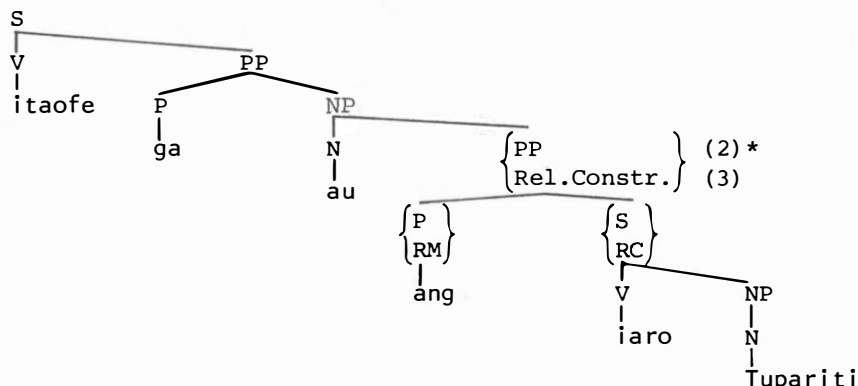

\*These alternatives represent the different analyses proposed by Pawley, Reid, and Starosta (2), and Sohn (3).

A structure similar in certain respects to Type I, is Mono-Alu's Type II relative clause. This type differs from Type I in that the modifier of the head noun introduced by *ang* (or variant *an*) is what appears to be a possessive construction, rather than a verbal sentence. For example:

TYPE II:

2261 i-safili ga batafa an sa-na numa  
17h 3s:nfut-exit abs woman rel thing-3s:pssv house  
*the head wife came out*

5488 i-lolofo ma ga mamaifa  
56a 3s:nfut-enter hither abs chiefly:woman

ang e-na rarami  
rel thing-3s:pssv food  
*the chiefly woman came into the house, for whom the food was*

5270 eang aanana an sa-ria iana  
52g those children rel thing-3p:pssv fish

iri-galo ama rarami  
3p:nfut-carry hither food  
*those children whose fish it was brought food*

Going on the assumption that a relative clause always consists of a sentence which is an attribute of a noun, the attribute introduced by *ang* in Type II constructions can be analysed as an equational sentence. Taking this approach, Type II sentences have the constituent structure shown in (T14).

Glosses for these sentences which reflect the nature of this analysis more accurately are:

2261 *the woman whose house it was come out*  
*the woman, her thing is a house, came out*

5488 *the chiefly woman for whom the food was came in*  
*the chiefly woman, her thing is food, came in*

5270 *those children whose fish it was brought food*  
*those children, their thing is a fish, brought food*

This analysis is warranted, and in fact suggested, by the fact that equational sentences of the same form as that hypothesised for the embedded sentences frequently occur independently of the relative construction.

(T14)

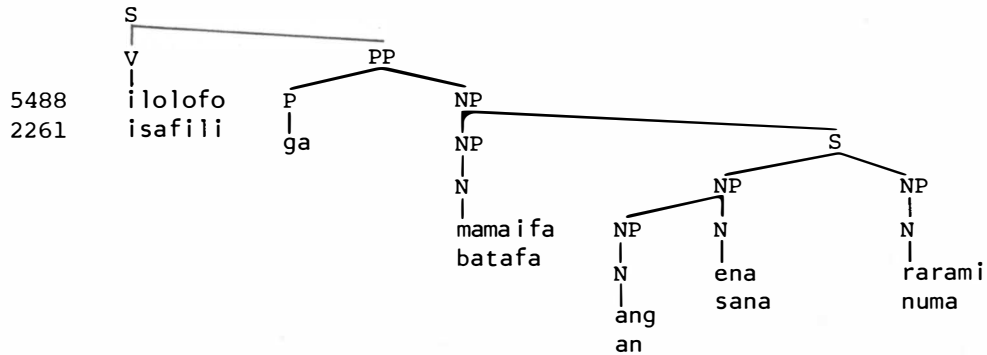

(Sentence 5270 has a similar structure, except for the fact that the head noun of the relative constituent is not part of a prepositional phrase in the higher sentence.)

The similarity between possessive constructions and one common type of equational sentence can be seen by comparing the following:

Possessive construction:

nife sa-na boo  
*snake thing-3s:pssv pig*  
*the snake's pigs*

Equational sentence:

mafa sa-gu Sameai  
*ls thing-ls:pssv Sameai*  
*Sameai (place name) is mine*  
*(my thing is Sameai)*

As a side note, this analysis of relative clauses also suggests an alternative analysis of alienable possessive constructions; namely that all alienable possessive constructions which consist minimally of sa/e-suffix plus a possessed noun may be equational sentences. As will be explained in section 4.1.1.3, however, it appears that this analysis is not compatible with lexicase's approach to handling case relations and the sister-head hypothesis.

As does the structure (T12) analysis of embedded verbal relative clauses, this analysis of equational relative clauses assumes that ang is a pronoun co-referential with the head of the construction. Type III constructions provide further evidence that ang (like its variant anta) is a nominal constituent.

TYPE III:

5311 ala iri-nasi ama ga ang i-lapu iana  
 52m *then 3p:nfut-pull hither abs rel 3s:nfut-kill fish*  
*then they pulled out the one who had killed the fish*

5371 anta iri-fa-mate-o ala fana-lapu-ri  
 54b rel 3p:nfut-caus-die-2s then 1s:fut-kill-3p  
*them who killed thee I will kill by and by*

(The relationship between ang and anta is not clear. Wheeler (46c3, p.303; 54b1, p.315) says that it is a combination of ang, the relative marker, and ita, a suffix that 'frequently occurs with verbs and other words' and whose function is currently indeterminate.)

Unlike Type I sentences, where ang introduces a sentential modifier of a head noun, Type III constructions contain no head noun. Thus it appears that ang functions as the head of a noun phrase, a pronoun which is modified by the embedded sentence. Further evidence that ang is a noun is provided by the fact that it is preceded by ga in 5311. In other constructions ga is always a case marker of nominal constituents.

Structure (T15) is proposed as the constituent structure for Type III relative clauses.

The fact that ga is a marker of nominal constituents, and that ang is marked by ga in Type III constructions argues in favour of the hypothesis that ang is a relative pronoun (alternative (1) above) rather than a preposition or conjunction (alternatives (2) and (3) above).

Treating ang as a preposition, for example, would necessitate hypothesising a rather unusual structure such as (T16) for Type III constructions.

In structure (T16), the higher prepositional phrase consists of a preposition and another prepositional phrase, rather than a preposition and a noun phrase.

(T15)

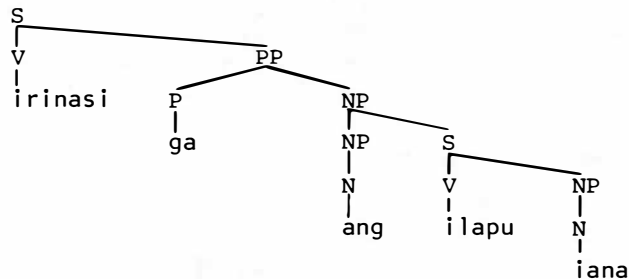

(The structure for 5371 is similar except that the relative clause is not introduced by the case marking preposition ga.)

(T16)

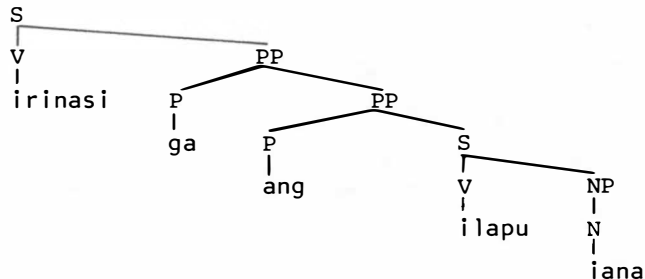

(T17)

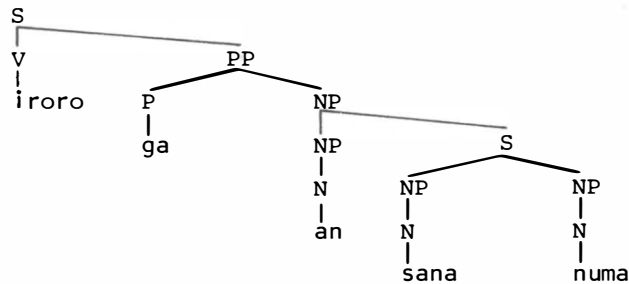

Just as Type II constructions can be analysed as equational counterparts to Type I constructions, Type IV constructions can be analysed as equational analogues to Type III constructions.

TYPE IV:

3408	i-roro	ga	an	sa-na	numa
34e	3s:nfut-see	abs	rel	thing-3s:pssv	house
	<i>the head wife</i>	<i>saw</i>	<i>her</i>		

The constituent structure for Type IV is as shown in structure (T17).

A more accurate gloss for structure (T17) would be:

3408	<i>the one whose house it is saw (her)</i>
	<i>the one, her thing is a house, saw (her)</i>
	(The bracketed <i>(her)</i> is not expressed in the Mono-Alu sentence.)

Though the analysis presented here is not based on sufficient evidence to draw any final conclusions, the distribution of *ang* in relation to other sentence constituents suggests that it is a nominal element and therefore that it may be possible to treat it as a relative pronoun rather than a prepositional ligature or a conjunction. A final conclusion, however, will have to be based on a considerable amount of further research.

Several other sentences show that the relative clause can be separated from the noun it modifies. For example:

2683	mafa aanana	ga	fana-galo-ri	ang	iri-anee	ma
21p	1s	children	abs	1s:fut-carry-3p	rel	3p:nfut-climb
	<i>I am going to carry off the children who climbed here</i>					
5789	tiong	i-soku	ma	ang	i-mate	
61a	man	3s:nfut-arrive	hither	rel	3s:nfut-die	
	<i>a man came here who had died</i>					

Like Type III constructions, these sentences show that *ang* can occur as an independent nominal element, and thus support the hypothesis that *ang* is a relative pronoun.



## CHAPTER 4

### EQUATIONAL SENTENCES AND NON-VERBAL STATIVE SENTENCES

#### 4. INTRODUCTION

This chapter proposes an analysis of two types of non-verbal sentences: equational and non-verbal stative. Both constructions are considered non-verbal because they do not contain inflected verbs.

Section 4.1 defines an equational sentence as any non-verbal sentence which 'equates' one noun phrase with another. This sense of 'equational' should not be understood to refer only to the strictest relationship of equivalence in which the two equated noun phrases are truly identical. Rather, included in these constructions are ones which indicate a looser equational relationship which might more accurately be called a taxonomic relationship. In such sentences, a subject noun phrase is asserted to be a member of a class named by a predicate noun phrase. The subject noun phrase is not strictly identical to the entity named by the predicate noun phrase.

Two syntactically distinct equational constructions are recognised. One consists simply of two noun phrases in juxtaposition. It is proposed that in this construction the first noun phrase is the subject (conveying old information) and the second noun phrase is the predicate (conveying new or asserted information).

The other equational construction consists of one or more noun phrases in combination with the morpheme *ga*. Considering certain syntactic properties of these constructions and the minimal semantic information provided by Wheeler's glosses, it is proposed that *ga* marks the noun phrase which follows it as the subject. The tentative conclusion drawn from this is that *ga* indicates a reversal of word order from NP[subj]-NP[pred] to NP[pred]-NP[subj]. This conclusion is supported by the fact that *ga* also marks the subject (Patient) in intransitive verbal sentences, but only when the subject follows the predicate (see chapter 5).

The non-verbal stative sentences discussed in section 4.2 consist of a noun phrase plus one of the forms discussed in section 3.1.2 (there called 'modifiers') which have been categorised as nouns. If the proposal that these forms are nouns is accepted, then the syntactic structure of non-verbal stative sentences is identical to that of equational sentences. Thus the two construction types cannot be distinguished on syntactic grounds, but only on semantic grounds. This semantic distinction will be discussed in section 4.2.0.

## 4.1 Equational sentences

### 4.1.0 Introduction

For the purposes of this study, an equational sentence will be defined as any non-verbal sentence which equates one noun phrase with another. Two syntactically distinct equational sentence types can be found in Wheeler's collection of texts. These two constructions consist of:

(1) two noun phrases in juxtaposition; these will be discussed in section 4.1.1, or

(2) one or more noun phrases in combination with the morpheme *ga*. Some of these constructions make use of a series of pronominal forms composed of *ga* plus a suffixed marker of person and number. These constructions will be discussed in section 4.1.2.

### 4.1.1 Equational sentences: noun phrases in juxtaposition

#### 4.1.1.1 Construction types

The general form of this construction is simply one noun phrase followed immediately by another. The complexity of both noun phrases can vary considerably.

(a) The simplest case consists of two unmodified nouns:

2062	mafa	poapoau
16n	ls	<i>ogress/man:killer</i>
		<i>I am a man killer</i>
2071	lea-gu	Kirifora
16o	name-ls:pssv	<i>Kirifora</i>
		<i>my name is Kirifora</i>
4747	nka-gu	atiati
48e	mother-ls:pssv	<i>ogress</i>
		<i>my mother is an ogress</i>

The constituent structure of these sentences is shown in structure (T18).

(T18)

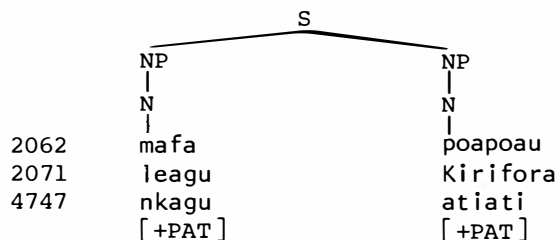

The equational relationship expressed by these sentences is indicated by the case relations of the two nouns involved. Both are in the Patient [+PAT] case relation.

(b) In a slightly more complex construction, one of the noun phrases is an inalienable possessive with the nominal possessor overtly expressed.



(T22)

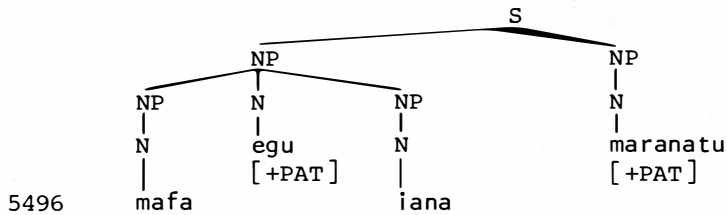

(d) The noun phrases often consist of a noun modified by one of the forms (tentatively categorised as nouns) discussed in section 3.1.2.

1138 mafa magota paitena  
 9f ls old:woman bad/evil  
*I am a useless old woman*

2475 mafa e-gu rarami iana eetana  
 20f ls thing-ls:pssv food fish raw  
*my own food is raw fish*

The structures posited for these sentences are given below in (T23) and (T24).

(T23)

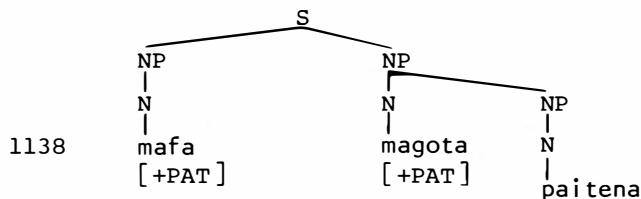

(T24)

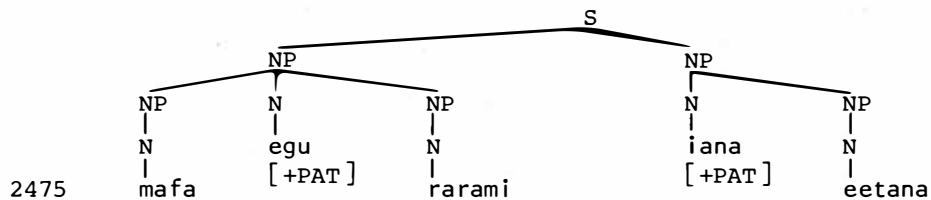

#### 4.1.1.2 Propositional structure

Without access to more detailed information about the context in which sentences such as these occur, it is difficult to draw any strong conclusions about the structure of the information they convey. The glosses provided by Wheeler, however, indicate that there is a strong tendency for the predicate noun phrase to be the second noun phrase in the sentence.

The hypothesis, then, is that the second noun phrase is the predicate of the sentence (containing new information) and the first noun phrase is its argument (containing old information):<sup>6</sup> NP[subj] NP[pred].

In light of the tendency for the subject noun phrase to precede the predicate noun phrase without any syntactic marker of their relationship, it is reasonable to postulate initially that this is the unmarked ordering of

constituents in Mono-Alu equational sentences. In section 4.1.2 I will propose that the morpheme *ga* may function as a marker which indicates a reversal of the unmarked ordering of constituents in equational sentences.

#### 4.1.1.3 Alienable possessives as equational sentences

Several of the type (c) sentences discussed above in 4.1.1.1 exhibit an interesting property which suggests an alternative analysis of the alienable possessive constructions discussed in chapter 1. Consider the possessive noun phrase *nife sana famata* *the snake's village* in sentence 2040 in comparison with the equational sentence 6411.

2040	mafa	nife	sa-na	famata	fana-roro	ma
161	1s	snake	thing-3s:pssv	village	1s:fut-see	hither
	<i>I am going to see the snake's abode</i>					
6411	Koriomu	sa-na	rariko			
66bb	<i>Koriomu</i>	<i>thing-3s:pssv</i>	<i>small:sticks</i>			
	<i>Koriomu had small firewood</i>					
	<i>(Koriomu's thing was small firewood)</i>					

Formally, the alienable possessive construction in 2040 is indistinguishable from the equational sentence 6411. This suggests at least two possibilities: (1) either sentence 6411 is a single noun phrase, structurally equivalent to an alienable possessive construction, or (2) alienable possessive constructions like *nife sana famata* (and related types) are equational sentences embedded in higher sentences.

Analysed as an equational sentence, 6411 has the constituent structure in (T25), and as a possessive noun phrase, the structure shown in (T26).

(T25)

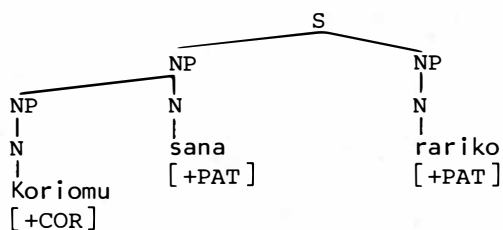

(T26)

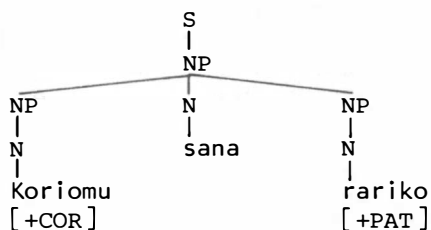
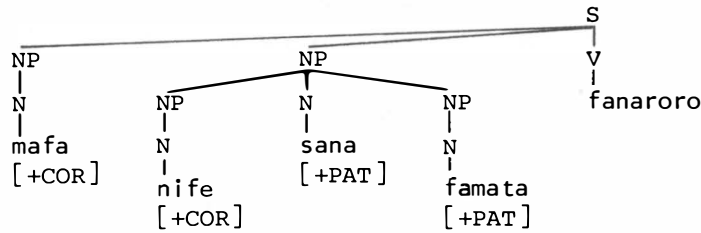
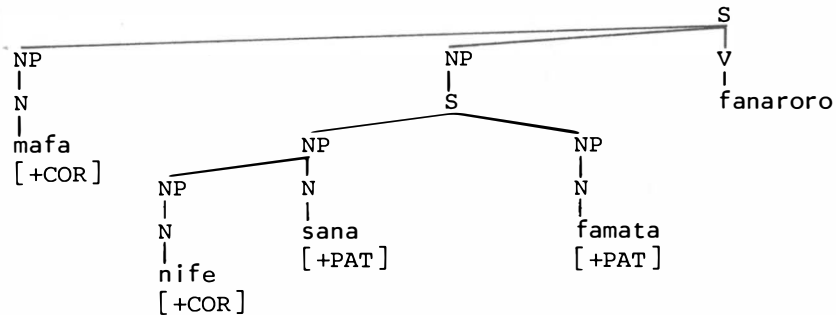

Diagram (T27) shows sentence 2040 with the structure proposed in section 2.2.2.3.2 assigned to the possessive construction. Structure (T28) analyses the possessive as an equational sentence.

(T27)



(T28)



The equational sentence analysis of possessive constructions works in all situations except one. Consider a sentence with a verb such as *roro see* which requires actants in the Correspondent and Patient case relations.

5563 natu-gu tiong i-roro-i  
 57b child-1s:pssv man 3s:nfut-see-tr  
 [+PAT] [+COR]  
 a man has seen my daughter

(T29)

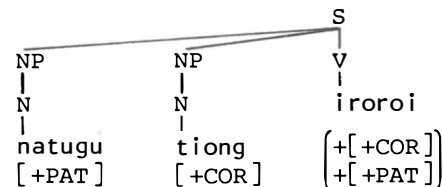

In sentence 5563 (T29), the seer, *tiong*, must be in the Correspondent case relation. If, however, the Correspondent in this sentence were replaced with a possessive construction such as *maita sara lalaafa our chief*, and if this possessive construction were analysed as an equational sentence with both head nouns in the Patient case relation, a conflict would result. This conflict is illustrated in structure (T30).

(T30)

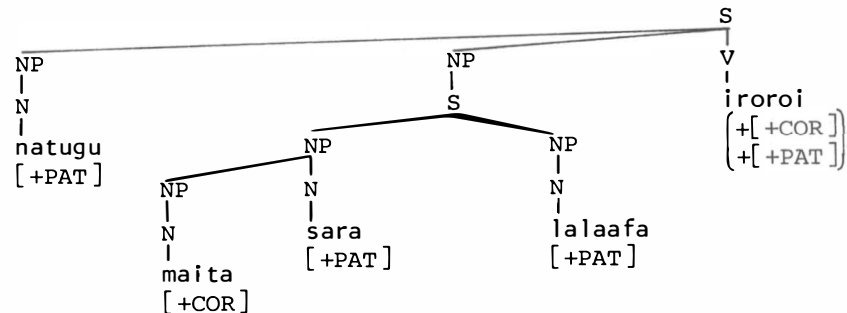

In (T30) both heads of the embedded sentence (an exocentric construction) are in the Patient case relation. Thus in the higher sentence, the verb has no sister constituent whose head noun carries the case relation feature [+COR]. Thus the verb's case frame requirements are not fulfilled and therefore the sentence is not well formed.

From this it can be concluded that the analysis of possessive constructions as proposed in chapter 2 is more appropriate than this one. The fact that alienable possessive constructions in general cannot be analysed as equational sentences does not, however, mean that the analysis of equational sentences like 6411 is incorrect.

#### 4.1.2 Equational sentences with ga

The major difference between the constructions to be presented in this section and those described in 4.1.1 is the presence of the morpheme ga in the sentences, and the use of a series of forms composed of ga plus a suffix indicating person and number.

The objectives of this section are (1) to describe the various forms of the construction, (2) to discuss the differences in propositional structure between these sentences and those described in 4.1.1, (3) to determine the function of ga in these sentences, and (4) to suggest a possible source of the ga-sfx forms.

Though the following discussion makes use of the term 'reversal' with regard to the order of subject and predicate noun phrases, the term is not intended to suggest that one order is in any sense more basic, or primary, than another, nor that one order precedes another historically.

##### 4.1.2.1 Construction types

All of the constructions in this category can be described as variations on two basic patterns, (e) and (f) in Figure 5.

As with the sentences discussed in section 4.1.1, it is difficult to draw any strong conclusions about the propositional structure of these sentences with access only to the information supplied by the texts. Based on Wheeler's glosses, however, there is a completely consistent pattern in type (e) sentences which indicates that the noun phrase immediately preceding ga is the predicate (new information) and that the sentence initial noun phrase (if present) and the suffix attached to ga (if present) refer to the subject (old information).

A majority of the glosses of type (f) sentences also indicate that the noun phrase immediately preceding ga is the predicate noun phrase, and that the noun phrase following ga is the subject noun phrase.

(e)	(NP) topic	NP pred	ga-(sfx)	Gloss
e.1				
6595	mafa ls	nife <i>snake</i>	ga-fa -1s	<i>I am a snake</i>
1463	maito 2s	batafa rekona <i>woman good</i>	ga-u -2s	<i>you are a comely woman</i>
6738	elea dem	lea-gu <i>name-my</i>	ga-ina -3s	<i>this one is my namesake</i>
5430	oang dem	maraka <i>bird</i>	ga-i -3s	<i>those are birds</i>
e.2				
2771	ea dem	tiong <i>man</i>	ga-∅	<i>this is a man</i>
6357	kefaia <i>wild yam</i>	rarami <i>food</i>	ga-∅	<i>wild yam is food</i>
e.3				
3737	∅	natu-ng <i>child-your</i>	ga-fa -1s	<i>I am your child</i>
6367	∅	saiga <i>garden</i>	ga-u -2s	<i>you are a garden</i>
5466	∅	tu-na <i>knee-his</i>	ga-i -3s	<i>it is his knee</i>
e.4				
389	∅	soi <i>commoner</i>	ga-∅	<i>it is a commoner</i>
2960	∅	sa-gu batafa <i>thing-my woman</i>	ga-∅	<i>it is my wife</i>
(f)	Gloss	NP pred	ga	NP subj
2344	<i>that is my sister- in-law</i>	ifa-gu <i>sister-in-law-my</i>	ga	ea dem
1467	<i>I am not a woman's daughter</i>	abu batafa natu-na <i>neg woman child-her</i>	ga	mafa ls
405	<i>this is your village</i>	sa-mia famata <i>thing-your village</i>	ga	emi dem
743	<i>this is its dung</i>	tai-na <i>dung-his</i>	ga	ena dem

Figure 5: Equational sentences with ga<sup>6a</sup>

If our attention is directed first to the type (f) sentences, the pattern appears to be that the predicate noun phrase precedes ga and that the subject noun phrase follows ga. The analysis proposed here is that the preposition ga marks the noun phrase which follows it as the subject, and that ga occurs in this position only when the subject follows the predicate. This analysis of



the function of *ga* in equational sentences is consistent with the analysis of verbal constructions in chapter 5. There it is proposed that *ga* precedes the subject (Patient) in intransitive sentences whenever the subject follows the verb. That is, *ga* marks the subject whenever the subject follows the predicate.

The analysis proposed for type (f) sentences is also adequate to account for types (e.1) and (e.3) provided that the *ga*-sfx forms are analysed as the result of the fusion of the preposition *ga* and a following pronominal form.

This possibility is suggested by the similarity between certain type (e) and (f) forms. The type (f) forms:

1467      *ga mafa*  
2344      *ga ea*  
405       *ga emi*  
743       *ga ena*

suggest that the type (e) forms

6595      *gafa*  
6439      *gaia*  
4543      *gaimi/gaemi*  
6738      *gaina*

may have resulted from a fusion of *ga* with a following pronoun. This may have been a diachronic phenomenon which included some phonological changes which would account for the differences in form between the fused forms and the separate forms. Figure 6 lists all the *ga*-sfx forms which occur in Wheeler's texts and illustrates their similarity to the *ma*-sfx series of pronouns and verb suffixes.

Person	<i>ga</i> -sfx	<i>ma</i> -sfx	Verb Suffixes	Possible source of <i>ga</i> -sfx forms
1s	<i>gafa</i>	<i>mafa</i>	<i>afa</i>	<i>ga-afa</i>
2s	<i>gau</i>	<i>maito</i>	<i>o</i>	<i>ga-o</i>
3s	<i>gai</i>	∅	∅	<i>ga-i</i>
1pI	?	<i>maita</i>	<i>ita</i>	?
1pE	<i>gami</i>	<i>mani</i>	<i>ami</i>	<i>ga-ami</i>
2p	<i>gang</i>	<i>maang</i>	<i>ang</i>	<i>ga-ang</i>
3p	(same as 3s)	∅	<i>ri</i>	(same as 3s)
Other	<i>gaia</i> <i>gaina</i> <i>gaimi</i>		<i>ga-ea*</i> <i>ga-ena</i> <i>ga-emi</i>	

Figure 6: Possible source of *ga*-sfx forms  
\**ea*, *ena*, and *emi* are all demonstrative pronouns

This analysis accounts for the function of *ga* in sentence types (e.3) and (f) and suggests a plausible source of the *ga*-sfx forms. It does not, however, explain the presence of the sentence initial pronouns in type (e.1) sentences in Figure 5. It may be that these forms occur in this position as topics. Thus type (e.1) sentences can be viewed as equivalent in form to type (e.3) sentences with the addition of a topicalised pronoun in sentence initial position.

Type (e.2) and (e.4) sentences differ from the other sentences in Figure 5 in that *ga* carries no suffixes and does not precede a noun phrase. These observations are difficult to accommodate within the present analysis, especially in view of the fact that in virtually all other constructions *ga* occurs preceding a noun phrase.

Because of this inconsistency with regard to the distribution of *ga*, a final conclusion as to its syntactic function in equational sentences will have to await further investigation. However, since the syntactic function of *ga* as proposed for sentence types (e.1), (e.3), and (f) is consistent with the syntactic function of *ga* in verbal constructions, this discussion will proceed on the hypothesis that the equational sentences which contain *ga* exhibit a reversal of the order of constituents found in the equational sentences discussed in section 4.1.1. That is, rather than the order NP[subj] NP[pred], these sentences have the order NP[pred] NP[subj], where the subject is marked by the preposition *ga*, and in some cases is represented as a reduced pronominal form suffixed to *ga*.

## 4.2 Non-verbal stative sentences

### 4.2.0 Introduction

Section 3.1.2 described the distribution of several forms which function as modifiers of nouns in Mono-Alu. Though these forms usually translate into English as adjectives, it was proposed in that section that their syntactic distribution is not distinct from the distribution of nouns, and that they should therefore be assigned to the same syntactic category as nouns.

This section is concerned with several of the same forms that were discussed in section 3.1.2. But here, these forms occur in sentences which, on semantic grounds, can be called stative sentences. The sentences can be understood to assert that a particular state of being (rather than activity) obtains with respect to a nominal constituent of the sentence. The sentences are considered non-verbal because they do not contain inflected verbs.

The distribution of these forms as described in section 3.1.2 led to the conclusion that they are nouns. As will be seen below, the form of the stative sentences provides additional support for the proposal that the distribution of these forms is not distinct from the distribution of nouns. For convenience, in this section I will use the term 'stative nominal' to refer to these forms whose distribution is like that of Mono-Alu nouns, but which translate into English as adjectives. To emphasise their nominal character, they will also be glossed as nouns; for example *reko good one* or *good thing* rather than just *good*.

The stative sentences are identical in form to the equational sentences described in section 4.1. In all but one stative construction (type (e.2), Figure 7) the stative nominal occurs in the predicate noun phrase position of the equational constructions of section 4.1.

#### 4.2.1 Construction types

Like equational sentences, Mono-Alu non-verbal stative sentences are of two basic types:

- (1) those that consist of a subject noun phrase followed immediately by a stative nominal, and
- (2) those that consist of a subject noun phrase, a stative nominal and the morpheme *ga*, with or without a suffix indicating the person and number of the subject.

The examples provided below indicate that these constructions are identical in all essential respects to the equational sentences. Thus, non-verbal stative sentences in Mono-Alu can be considered a semantically distinguishable sub-type of equational sentence.

##### 4.2.1.1 Noun phrase and stative nominal in juxtaposition

The most abundant of the non-verbal statives found in Wheeler's texts are those which consist of a subject noun phrase together with a stative nominal. In all cases, the stative nominal follows the subject. As with the noun phrases in equational sentences, the complexity of the subject noun phrase can vary considerably.

(a) The simplest construction is a single unmodified noun followed by a stative nominal. These resemble equational sentence type (a) most closely.

- |      |                                   |                   |  |
|------|-----------------------------------|-------------------|--|
| 304  | rarami                            | rekona            |  |
| 3e   | <i>food</i>                       | <i>good:thing</i> |  |
|      | <i>the food is good</i>           |                   |  |
|      | <i>(the food is a good thing)</i> |                   |  |
|      |                                   |                   |  |
| 1600 | tatai                             | paitena           |  |
| 14b  | <i>dung</i>                       | <i>bad:thing</i>  |  |
|      | <i>dung is a bad thing</i>        |                   |  |

(b) Like the type (b) equational sentences, a slightly more complex construction involves a subject noun phrase which is an inalienable possessive with overtly expressed nominal possessor.

- |     |   |                       |                |
|-----|---|-----------------------|----------------|
| 915 | Merafa  | nka-na                | paitena        |
| 8f  | <i>Merafa</i>   | <i>mother-3s:pssv</i> | <i>bad:one</i> |
|     | <i>Merafa's mother is a bad woman</i>                         |                       |                |
|     | <i>(Merafa's mother is a bad one)</i>                         |                       |                |
|     | <i>(Sentence 5510 is identical in form, but has the gloss</i> |                       |                |
|     | <i>my mother is unkind.)</i>                                  |                       |                |

5514 mafa nka-gu rekona  
 56d ls mother-1s:pssv good:one  
*my mother is kind*  
*(my mother is a kind one)*

(c) Alienable possessive constructions also occur in the subject noun phrase position. This construction is most like equational sentence type (c).

1939 nife sa-na boo rekona  
 16d snake thing-3s:pssv pig good:thing  
*the snake's pigs are good*  
*(the snake's pigs are good ones)*

2823 maang sa-mia tataru paitena  
 22h 2p thing-2p:pssv custom bad:thing  
*your custom is a bad one*

The fact that the stative nominals occur in the same position as predicate noun phrases in equational sentences is additional evidence which supports the hypothesis that these forms are nouns. In section 4.1 it was pointed out that there is a strong tendency for the predicate noun phrase to follow the subject noun phrase. The position of the stative nominal in these sentences is consistent with this pattern.

#### 4.2.1.2 Non-verbal stative sentences with ga

Wheeler's texts contain examples of stative sentences which are identical in form to all of the type (e) and (f) equational sentences. The sample of these sentences is not as large as the sample of equational sentences, but all the construction types are represented. The distribution of ga is the same as it is in the equational sentences, and many of the same ga-sfx forms are represented in these constructions.

Figure 7 contains all of the non-verbal stative sentences with ga or ga-sfx forms which occur in Wheeler's collection. This chart has been organised in accordance with the above proposal that (1) the order of constituents in equational sentences with ga is (NP[topic]) NP[pred] ga-(sfx) or NP[pred] ga (NP[subj]), (2) stative nominals have a syntactic distribution identical to other nouns, and (3) non-verbal stative sentences are a sub-type of equational sentence.

In contrast with the other sentence types in Figure 7, in type (e.2) sentences, the stative nominal occurs in subject noun phrase position rather than in predicate noun phrase position. Because of the glosses assigned to these examples by Wheeler, these sentences might mistakenly be viewed as exhibiting a reversal of the NP[pred]-NP[subj] word order hypothesised for these constructions. However, there would be no apparent explanation for such a reversal of constituent order. It would be more consistent with the analysis to propose, as is done here, that both constituents are nouns and that type (e.2) sentences are structurally identical to type (e.1) sentences. They differ only in that the stative nominal is the predicate noun phrase in (e.1) but is the subject noun phrase in (e.2).

(d)	NP topic	N (stative pred nominal)	ga-(sfx)	Gloss	
d.1					
1016	maito 2s	paitena <i>bad</i>	ga-u -2s	<i>you are an evil one</i>	
2442	mafa 1s	mamaa <i>heavy</i>	ga-fa -1s	<i>I am heavy</i>	
3285	mafa 1s	salena <i>alive</i>	ga-fa -1s	<i>I am a living man</i>	
5404	eaang Tunupa det <i>Tunupa</i>	tibona <i>alone</i>	ga-i -3s	<i>this Tunupa is alone</i>	
6777	maito Biriaini 2s <i>Biriaini</i>	olatu <i>taboo</i>	ga-u -2s	<i>you, Biriaini, are taboo</i>	
6822	maito 2s	olatu <i>taboo</i>	ga-u -2s	<i>thou art indeed taboo</i>	
d.2					
722	eaang det	paitena <i>bad</i>	ga-∅	<i>this is no good</i>	
1247	reang talaiba det <i>women</i>	rekona <i>good</i>	ga-∅	<i>those women are comely</i>	
2043	boo <i>pig</i>	paitena <i>bad</i>	ga-∅	<i>the pigs are no good</i>	
6263	kiniu <i>canoe</i>	taposana <i>broken</i>	ga-∅	<i>the canoe is broken</i>	
d.3					
5389	∅	tibona <i>alone</i>	ga-i -3s	<i>he is alone</i>	
6549	∅	olatu <i>taboo</i>	ga-u -2s	<i>you are taboo</i>	
d.4					
2977	∅	salena	ga-∅	<i>they are alive</i>	
(e)	NP pred	(stative nominal)	ga-∅	NP subj	Gloss
e.1					
742	paitena <i>bad</i>	ga	ena dem:pron		<i>this is no good</i>
746	rekona <i>good</i>	ga	ena dem:pron		<i>this is good</i>
3812	lualua <i>small:amount</i>	ga	rarami <i>food</i>		<i>we have only a little food</i>
6028	rekona <i>good</i>	ga	abesolo <i>creeper</i>		<i>creeper is a good thing</i>

Figure 7 continued ...

... continued

(e)	NP pred	(stative nominal)	ga-∅	NP subj	Gloss
e.2					
227	rarami <i>food</i>	kokong <i>taro</i>	ga	rekona <i>good</i>	<i>the food taro is good</i>
723	ea dem:pron		ga	rekona <i>good</i>	<i>that is good</i>
2444	maito 2s		ga	kanegana <i>big</i>	<i>are you fat?</i>
2719	mafa 1s		ga	kairikina <i>small</i>	<i>I am little</i>
2792	rarami <i>food</i>	ea det	ga	rekona <i>good</i>	<i>this food is good</i>
3200	nka-gu <i>mother-my</i>		ga	paitena <i>bad</i>	<i>my mother is an evil woman</i>

Figure 7: Non-verbal stative sentences with ga<sup>6b</sup>

(In 6777 Biriaini is in apposition to maito. Notice that sentence 1247 can be analysed equally well with reang as a demonstrative pronoun subject and talaiba rekona as a predicate noun phrase. With this analysis, the sentence would be a type (e.2) equational sentence (see section 4.1).)

If this analysis is correct, it would be more accurate to gloss type (e.2) sentences as follows. For example:

- 227     *the good one is the food taro*, rather than Wheeler's  
          *the food taro is good*
- 723     *the good one is this one*, rather than Wheeler's  
          *this is good*

The fact that stative nominals occur both in the position of predicate noun phrases (d.1-e.1) and subject noun phrases (e.2) is further evidence that their syntactic distribution is identical with that of other nouns.

## CHAPTER 5

### VERBAL CONSTRUCTIONS

#### 5. INTRODUCTION

Chapter 5 consists of three major sections. Section 5.1 introduces the lexicase approach to analysing verbal constructions. Certain assumptions provided by the lexicase theory of case grammar are discussed, and definitions of some terms and concepts are given. Section 5.2 briefly summarises some generally accepted views concerning characteristics of verbal constructions typical of Oceanic languages. This is essentially an overview of Andrew Pawley's work on the grammar of proto-Oceanic verbal constructions (Pawley 1973, 1978). Section 5.3 describes the major verbal constructions found in Mono-Alu as the language is represented by Wheeler's texts. Discussions of inflectional morphology, intransitive, transitive, and semitransitive constructions and verbal derivation are included.

One of the major, and most problematic, issues addressed in section 5.3 concerns the syntactic function of the preposition *ga* and the inflectional prefixes and suffixes of verbs. It is assumed that all three are case markers, that is, language specific markers of case forms. Based on the association of these case markers with actants in certain case relations, it is concluded that *ga* is Mono-Alu's marker of the absolutive case form which realises only the Patient case relation in both transitive and intransitive sentences. Verb agreement suffixes, on the other hand, occur only in transitive sentences and always agree with the actant in the Patient case relation. Verb suffix agreement is therefore held to be a marker of the accusative case form which realises the Patient case relation.

Unlike verb suffixes, verb agreement prefixes occur in both transitive and intransitive sentences. In intransitive sentences the verb prefix agrees with the actant in the Patient case relation. In transitive sentences, however, the verb prefix agrees with either the Agent or Correspondent, depending on the syntactic class of the verb involved. This distribution of prefix agreement with respect to case relations leads to the conclusion that verb prefix agreement is Mono-Alu's marker of the nominative case form.

From this brief outline of the correspondence between case markers and case relations, it can be seen that the preposition *ga* (marker of the absolutive case form) and verb prefix agreement (marker of the nominative case form) coincide in intransitive sentences where they are both associated with the actant in the Patient case relation. In contrast to this, in transitive sentences verb suffix agreement (marker of the accusative case form) and *ga* coincide, both being associated with the actant in the Patient case relation.

Based on this distribution of case markers with respect to case relations it appears that Mono-Alu's case marking system exhibits characteristics of both accusative and ergative case marking systems: the distributions of prefix agreement (nominative) and suffix agreement (accusative) are characteristic of an accusative case marking system, and the distribution of *ga* (absolutive) is characteristic of an ergative case marking system.

More detailed discussion of these case marking patterns and samples of the data which led to these conclusions will be given below in section 5.3.

## 5.1 Lexicase analysis of case marking systems

In lexicase theory, the case marking system of a language can be described by specifying the relationships among three entities: (a) case relations, (b) case forms, and (c) case markers. General definitions of these terms have been given above in the outline of lexicase theory (section 1.3.2.4). In the following sections I will propose a set of case relations for Mono-Alu and explain how they correspond to case forms and case markers. My conclusion will be that eight case relations are needed to account for the sentence types found in Wheeler's texts. These case relations are: (1) Agent, (2) Patient, (3) Instrument, (4) Locus, (5) Place, (6) Correspondent, (7) Reference, and (8) Concomitant.

### 5.1.1 Case relations

Except for Concomitant, this inventory of case relations is drawn from the set defined by Stanley Starosta in "The one/sent solution" (Starosta 1977). This section will simply list the case relations recognised for Mono-Alu, define each one, and explain the general criteria used in deciding what case relation holds between a nominal constituent and a verb, or between two nominal constituents.

**PATIENT [+PAT].** The Patient case relation is defined as the fundamental case relation. A more precise definition of this case relation must take into consideration the class of verb involved. For example, with an affect verb the Patient is the entity which is viewed as affected by the action of the verb. With motion or location verbs the Patient is the entity viewed as moving or being located in abstract or concrete space. With stative verbs the Patient is the entity viewed as existing in a state, or changing in state. And with psychological verbs, the Patient is the entity that triggers or constitutes the content of a psychological experience (Starosta 1977:9-11).

**AGENT [+AGT].** The Agent is the non-immediate perceived causer of the action of the verb. In establishing the presence of an actant in the Agent case relation, several points should be kept in mind. The Agent must always co-occur with a Patient. The Agent must act on something disassociated from itself. It may be the case that the Patient is not physically separate from the Agent, but it must at least be conceptually and syntactically separate. An Agent always implies an Instrument, but it may be difficult or grammatically impossible to express it (ibid.:7, 12-15).



INSTRUMENT [+INS]. The Instrument is the entity perceived as the immediate effective cause of the action or event referred to by the verb. The Instrument is controlled by the Agent if present, by the Correspondent if an Agent is not present, or by the Patient if neither Agent nor Correspondent is present. An Instrument may be animate or inanimate, and may be concrete or abstract (ibid.:13-16).

LOCUS [+LOC]. Locus is an inner case relation in the sense that it specifies the location of only the actant in the Patient case relation. The Locus does not always specify a concrete spatial location. Depending on the class of verb, it may specify a spatial, conceptual, proximal or legally defined location. As an inner case relation, the Locus usually does not specify the location of the Agent. Locus generally occurs with a restricted range of verbs, and therefore can be used to subcategorise verbs (ibid.:20).

PLACE [+PLC]. Place is distinguished from Locus by the criterion that it is an outer, rather than inner, case relation. Instead of specifying the location of the Patient alone, it sets the scene for the action or state as a whole. In this capacity, the Place case relation can co-occur with any verb and therefore cannot be used to define verb classes (ibid.:20).

CORRESPONDENT [+COR]. This case relation was called 'Experiencer' in "The one/sent solution", but has since been renamed Correspondent presumably to suggest a less restricted range of relationships. The name has changed, but the definition has not. The Correspondent is the case relation of the entity that is placed in correspondence with the Patient, and is often (but not always) an animate entity that undergoes a psychological experience, the content of which is represented as the Patient. The Correspondent is often an indirect experiencer of the state of the Patient.

Since the Correspondent enters into a relationship exclusively with the Patient, it is an inner case relation and therefore can be used to define verb classes (ibid.:22-23).

REFERENCE [+REF]. 'Benefit' was the name of this case relation in "The one/sent solution" but as with Correspondent, Reference suggests a broader range of relationships. The Reference case relation can be distinguished from the Correspondent by the fact that it is an outer case relation. Rather than defining a relationship only with the Patient, the actant in the Reference case relation identifies the 'target or evaluative reference point of the action or state as a whole'. Since it is an outer case relation, it cannot be used as a criterion for verb subcategorisation (ibid.:23).

CONCOMITANT [+CON]. As defined by Harvey Taylor, an actant in the Comitative case relation is '... associated in a parallel way with ... another actant in the verbal activity or state described (in Starosta 1976a:1081)'. In keeping with Harmon's (1977) convention of reserving terms ending in *-ive* for case forms, Taylor's comitative case relation will go by the name Concomitant in this study.

### 5.1.2 Case forms and case markers

In the process of considering the correspondence among case forms, case markers, and case relations in Mono-Alu, it is important to keep clearly in mind the status of each of these three concepts. Case relations are universal concepts which define the nature of the relationship that holds between a

nominal constituent and the head of its construction. Case forms are formal syntactic features which mark nominal constituents and indicate the presence of a case relation. Case forms are universally recognisable syntactic devices. Case markers are language specific syntactic devices which directly or indirectly indicate the presence of a case form on a nominal constituent.

A direct case marker is an overt morphological marker on the noun itself, as is found in languages in which nouns are inflected for case. This type of case marker corresponds to the traditional notion of case inflection.

In recent treatments of case grammar, however, the concept of case marker 'has been extended to cover any syntactic or morphological configuration that seems to have the same function as the case inflections do in Latin, in particular, any configuration that marks a nominal constituent as having a certain relation to the main verb of a sentence' (Starosta 1976b:1-2).

As noted elsewhere by Starosta (1976a:1071), such grammatical devices as subject and object agreement, word order, and prepositions are also considered to be markers of case relations. I will refer to these sorts of devices as indirect case markers since they do not occur directly as markers of nouns themselves. Nevertheless they do signal the presence of a case form feature which realises the case relation of the head noun of the associated nominal constituent.

### 5.1.3 Subjects, objects, and transitivity

While the traditional terms 'grammatical subject' and 'grammatical object' have some intuitive meaning to most literate individuals, their status as technical terms seems at times to be disputed and perhaps inconsistent (see Lyons 1968 sections 8.1 and 8.2). It is often unclear whether these terms are intended to indicate the kinds of relationships defined here by case relations, or whether they are viewed as syntactic devices like case forms, or some combination of both. In addition, the notion of transitivity is not always clearly defined.

In order to avoid any possible confusion due to the use of these terms, in this analysis of verbal constructions I will try to avoid the use of 'subject' and 'object' as much as possible, and will provide a formal definition of the term 'transitivity'.<sup>7</sup>

Instead of talking about nominal constituents standing in a subject or object relationship to a verb, the following discussion will make use of the relationships defined by case relations as much as possible. In order to do this it will be convenient to make use of another term, *protagonist*, which was suggested to me by Stanley Starosta. The term protagonist refers to the highest ranking member of a hierarchy of case relations. In a sentence with a verb that allows an actant in the Agent case relation, the Agent is the protagonist. If the verb does not allow an Agent, but does allow a Correspondent, then the Correspondent is the protagonist. If neither an Agent nor a Correspondent is allowed in the case frame of the verb, then the Patient is the protagonist.

This hierarchy will, of course, be recognised as the subject choice hierarchy common to languages with an accusative pattern of case marking. It is the case in Mono-Alu that the protagonist is always realised by the nominative case form.

The difference between transitive and intransitive verbs has been defined formally by Pranee Kullavanijaya as follows. Transitive verbs are verbs which 'take anything other than a Patient as their unmarked subject choice'; that is, something other than the Patient is realised by the nominative case form. Intransitive verbs are verbs which 'take Patient subject'; that is, the Patient is realised by the nominative case form (Kullavanijaya 1974:106).

In the present discussion, transitive verbs have Agent or Correspondent protagonists, and intransitive verbs have Patient protagonists. Notice that this conception of transitivity and intransitivity is not concerned with the number of, or semantic relationships among, nominal constituents in a sentence. The definition is stated only in terms of the correspondence between case relations and case forms.

#### 5.1.4 Assumptions

This analysis of Mono-Alu's case marking system rests on some theoretical assumptions provided by the lexicase theory of case grammar as described in Starosta (1977).

(1) Every verb, with the exception of meteorological verbs in some languages, has an actant in the Patient case relation in its case frame (Starosta 1977:9, 10, 34). From this assumption and the definition of transitivity given above, it follows that a verb which allows only one actant in its case frame, or which allows neither an Agent or a Correspondent, is an intransitive verb.

(2) Only one instance of an actant in a particular case relation can occur in a simple sentence unless the multiple occurrences mark actants that are co-referential, inclusive, or successive segments of a path (ibid.:2, 8).

(3) I will also provisionally accept the hypothesis that '... all overt case markers which are phonologically identical are also syntactically identical ...' (Starosta 1973:3). As is pointed out elsewhere in the same paper, this hypothesis may be too strong. Even so, it provides a heuristic principle which is useful in guiding a preliminary investigation such as this one.

#### 5.1.5 Ellipsis

Probably the most frequently occurring sentence type in Wheeler's texts consists simply of an inflected verb with no nominal constituents of any kind. In such sentences, nominal arguments of the verb are represented only by the verb's inflectional affixes. These sentences appear to conflict with assumption number one above.

This conflict can be avoided, however, by assuming that nominal constituents are absent from such sentences due to ellipsis rather than due to syntactic properties of the verbs involved. If this assumption were not accepted, it would be necessary to propose that for virtually every Mono-Alu verb there is a derivationally related verb which allows no nominal constituents. The assumption that the absence of these noun phrases is due to ellipsis is in accord with Gunther's proposal that absence of a noun phrase can be assumed to be due to ellipsis if 'the deleted player is reconstructable and identifiable by the present or presupposed context of the sentence, and not just on the

basis of the selectional restrictions of the verb' (Gunther 1975:68-69 in Starosta 1977:10).

In the following discussion of verbal constructions, whenever an obligatory actant is mentioned, it should be understood that the syntactic properties of the verb require the presence of a nominal constituent with certain syntactic characteristics, but that in some contexts this syntactically obligatory constituent may be redundant, and thus may be elliptically omitted.

## 5.2 Verbal constructions in Oceanic

### 5.2.0 Introduction

This summary is included here in order to place the following analysis of Mono-Alu verbal constructions in a wider context. By reviewing some generally accepted views on what is typical of verbal constructions in Oceanic it will be possible to see how Mono-Alu's system fits into the general picture of Oceanic grammar as it is developing. Points of similarity and difference between Mono-Alu and proto-Oceanic as described by Pawley (1973, 1978) will be noted.

#### 5.2.1 Word order in Oceanic

For intransitive sentences, Pawley reconstructs the preferred word order as SV, but notes that in many contemporary languages this order alternates with VS (Pawley 1978:4.21). In Wheeler's Mono-Alu texts, both orders are found with about equal frequency. However, SV order is unmarked, while in VS sentences, the subject noun phrase (in this analysis, the actant realised by the nominative case form) is introduced by the preposition *ga*.

For transitive sentences, SVO is reconstructed by Pawley as the unmarked order. He adds, however, that this is only the preferred order, and that this preference is often violated. Thus he warns that word order cannot be used as a diagnostic criterion for identifying subjects and objects. Several contemporary languages are exceptions to the reconstructed order; for example Fijian prefers VOS and many New Guinea languages prefer SOV order (Pawley 1978:1.27, 4.16-4.19).

All possible permutations of the constituents S, V, and O can be found in the transitive sentences in Wheeler's texts, but two orders tend to occur more frequently than others. Constructions with SOV and SVO orders seem to be most common, with SVO perhaps slightly more frequent than SOV. However, it should be noted that when the object precedes the verb it is unmarked, while when following the verb it is introduced by the preposition *ga*. The constituent referred to informally as the 'object' in this discussion will be referred to formally as the Patient in later sections.

## 5.2.2 Verbal constructions in Oceanic

### 5.2.2.1 The proto-Oceanic 'verb-phrase'

Pawley (1978:4.2-4.3) uses the term 'verb phrase' to refer to a constituent which consists minimally of a verb with its marker of tense, aspect, or mood, and optional markers of direction or manner. This is the basic verb phrase. The basic verb phrase together with a preposed subject person marker, postposed object person marker and optional modifying bases is called the expanded verb phrase.

Pawley seems to view the subject and object person markers as elements which are to some extent independent of the verb base. In contrast to his approach, in this analysis of Mono-Alu, subject and object person markers will be viewed as inflectional affixes of the verb. This approach is a reasonable one since the markers never occur in non-verbal constructions, and are separated from the verb base only by derivational affixes.

### 5.2.2.2 Intransitive constructions in Oceanic

Two intransitive constructions, stative and active, are recognised by Pawley (1978:4.3, 4.14, 6.1), and are distinguished both by semantic and syntactic properties.

A stative construction contains a stative basic verb phrase and a single noun phrase or person marker which refers to the experiencer of the state described by the verb. Syntactic characteristics of stative verbs include: (1) an actor or goal noun phrase cannot be added without changing the syntactic class of the verb. (2) Transitive verbs can be derived from most statives either by (a) prefixing \*paka and suffixing (in most cases) a transitive suffix \*i or \*aki(ni), or (b) simply adding a transitive suffix. Presumably a given verb base will use only one of these transitivising strategies. (3) Nouns which occur as subjects of the derived transitive verbs are not drawn from the same class as nouns which occur as subjects of the related intransitive forms.

An active intransitive verb lacks a transitive suffix and a direct object person marker. An intransitive active sentence contains, minimally, a single unmarked noun phrase, the subject, which refers to the actor or experiencer of the activity described by the verb. Most of these verbs also occur transitively, but unlike transitives derived from statives, nouns which occur as subjects of intransitive active verbs are drawn from the same class as are nouns which serve as subjects of the derivationally related transitive verbs.

Mono-Alu intransitive constructions differ from the proposed POC reconstruction in two fundamental respects. First, the subject noun phrase is not always unmarked. As will be seen in section 5.3.2, with very few exceptions, the subject is marked by the preposition *ga* when following the verb. Second, the strategy of deriving transitives from intransitives by prefixing a reflex of \*paka and adding a transitive suffix is not restricted to semantically stative verbs in Mono-Alu. There are several active intransitives which derive transitives in this way. For example: *anee go up, climb*, *fa-ane-i bring up, cause to rise*, *lolofo come or go into*, *fa-lolof-i bring into*, *sae go up, go inland*, *fa-sae take up*. Verbal derivation will be discussed more fully in section 5.4.

### 5.2.2.3 Transitive constructions

A proto-Oceanic verb is transitive if it carries either (a) a transitive suffix \*i or \*aki(ni), or (b) a suffixed or postposed person marker. Many transitive verbs have both characteristics (a) and (b), but (b) is diagnostic of transitive verbs (Pawley 1978:1.28-1.29).

Pawley recognises two subclasses of transitives: optional and obligatory. Optional transitives are those which occur both in transitive and intransitive constructions, the transitive form being derived by suffixing \*i or \*aki(ni), or a person marker to the intransitive base. This subclass is identical to the active intransitives mentioned above (Pawley 1978:6.7).

Obligatory transitives occur only in transitive constructions, and meet requirements (a) or (b) or both (Pawley 1978:6.10).

Both optional and obligatory transitives are found in Mono-Alu.

### 5.2.2.4 Incorporated object constructions

A construction with properties of both transitive and intransitive sentences is reconstructed for POC by Pawley. These constructions have the canonical properties of transitive sentences. That is, in such constructions a noun phrase occurs which appears, semantically, to be an object noun phrase. The verbs, however, lack transitive suffixes and object person markers. Pawley calls these 'incorporated object' constructions and states that the evidence favours treating them as intransitive constructions (Pawley 1978:4.7, 4.11-4.12).

For reasons that will be explained in section 5.3.4, Mono-Alu constructions which resemble these will be treated as syntactically intransitive.

## 5.3 Verbal constructions in Mono-Alu

### 5.3.1 Inflectional affixes

The inflectional affixes for Mono-Alu verbs recognised by Wheeler are given in the chart in Figure 8.

PERSON	PREFIXES		SUFFIXES
	NON-FUTURE	FUTURE	
1s	fai	fana	afa
2s	oi	ona	o
3s	i	ena	i, ng
1pI	tai	tara	ita
1pE	ami	ama	ami
2p	ang	emia	ang
3p	iri	eria	iri
	re	rea	ri

Figure 8: Wheeler's inflectional affixes for verbs

### 5.3.1.1 Prefixes

Verb prefixes indicate tense/mode and mark the person and number of actants realised by the nominative case form. (Justification for proposing that prefix agreement marks the nominative case form will be given in section 5.3.2.)

Especially in the singular forms, it is fairly obvious that the prefixes can be analysed into two morphemes: (a) *fa*, *o*, zero/*e* indicating person and number, and (b) *i/na* indicating the distinction Wheeler labels as non-future/future. However, since the morpheme break cannot consistently be made in all the forms, each will be treated as a single inflectional prefix indicating tense/mode and marking the person and number of the actant realised by the nominative case form.

Though Wheeler says that the two sets of prefixes indicate a distinction between future and non-future, the notes to several of his texts indicate that the distinction may not be quite so simple. In several notes he comments that the 'future' prefixes denote repeated, habitual, or extended action in the past, or seem to indicate a meaning akin to subjunctive (see for example notes 28b1, 65r3, 67x6). Thus it may be more accurate to describe the distinction as one of *realis/irrealis* rather than non-future/future. John Lynch's discussion of the *realis/irrealis* distinction in Oceanic appears to favour this analysis (Lynch 1975:94-95).

How to treat this distinction is a decision which should be based on further research. For the time being I will continue to use Wheeler's non-future/future terminology.

It will also be noted that there is some variation in the third person plural forms. As far as can be determined from Wheeler's comments and the translations to the texts, the alternative forms do not indicate a distinction in meaning.

In addition to the forms listed in the chart, there are two other variant forms of *iri*: *in* and *ing*. These forms occur in a few sentences throughout the texts. There appears to be no pattern on which to base a phonological explanation for these two variants. An explanation of these forms will also have to await further research.

### 5.3.1.2 Suffixes

As will be explained in section 5.3.3, inflectional verb suffixes agree in person and number with the actant realised by the accusative case form.

The present analysis of the function of verb suffixes agrees with Wheeler's in all respects except one. He analyses the suffixes *i* and *ng* as markers of third person singular objects. While it is true that these markers frequently occur with third person singular objects, it will be proposed below in section 5.3.3 that both *i* and *ng* are derivational suffixes which derive transitive verbs from intransitive verbs. Consequently, the third person singular suffix must be zero.

Analysing *i* as a derivational suffix also accounts for the variation in the form of the third person plural suffix.

It is quite clear that *i* corresponds to the transitive suffix \**i* reconstructed for proto-Oceanic. The status of *ng*, however, is not so certain. Not enough is known about sound correspondences between Mono-Alu and POC to confidently propose that *ng* is a reflex of the other POC transitive suffix \**aki(ni)*.

### 5.3.2 Intransitive constructions

#### 5.3.2.1 Sentence types and their constituents

Mono-Alu intransitive verbs are of two types: (a) those which indicate motion or location, and (b) those which indicate that something is in a particular state or is participating in some activity. While there may be a meaningful distinction between being in a state and participating in an activity, in many cases it is difficult to decide which point of view would be the most appropriate analysis for a particular verb or sentence. Given the minimal amount of semantic information available for this analysis and acknowledging the fact that stative and activity verbs appear to behave similarly with regard to syntax, they will be treated as a unit in this study.

Nor are there significant differences in the syntactic behaviour of motion/location verbs in comparison with stative/activity verbs. The word order of the two types, as well as their privileges of co-occurrence with other sentence constituents, appear to be very similar. For this reason, all of the intransitive verbs can be treated as members of a single syntactic class.

Subject to ellipsis considerations (see 5.1.5) intransitive sentences consist minimally of an inflected verb and actant in the Patient case relation, and maximally (disregarding time and direction adverbials) of an inflected verb together with actants in the Patient, Locus, and Concomitant case relations.

With motion/location verbs, the Patient actant refers to the entity that moves or is located in space. With stative/activity verbs, the Patient actant refers to the entity which is in the state described by the verb, or which participates in the activity described by the verb.

The Locus actant specifies the location of the Patient.

The Concomitant actant in intransitive sentences identifies the entity which accompanies the Patient in the event or state described by the verb.

Except for one, all possible combinations of a verb and these three nominal constituents are represented in Wheeler's collection of folktales. It is assumed that the Patient is elliptically omitted from sentences where one does not occur.

#### (a) VERB ALONE

4155      *iri-lolofo*  
410        *3p:nfut-enter*  
            *they went in*

#### (b) VERB WITH ONE NOMINAL CONSTITUENT

##### (b.1) VERB AND PATIENT

6046      *sorau      i-gafulu*  
651        *fish:net 3s:nfut-ready/finished*  
            *the fish net was ready*



## (b.2) VERB AND LOCUS

3115      iri-gagana    kalofo            a  
 29e      3p:nfut-go    meeting:house    loc  
           they went to the meeting house

## (b.3) VERB AND CONCOMITANT

3379      re-eo                    Kitolo    ua  
 34c      3p:nfut-lay/lie    Kitolo    with  
           he and Kitolo lay together  
           (they lay together, with Kitolo)

## (c) VERB WITH TWO NOMINAL CONSTITUENTS

## (c.1) VERB WITH PATIENT AND LOCUS

5921      Soi    tiga    numa    ena-safili  
 65a      Soi    from    house    3s:fut-come:out  
           Soi would come out of the house

## (c.2) VERB WITH PATIENT AND CONCOMITANT

3259      batafa    sa-na                    kanega    ua    iri-mate  
 32c      woman    thing-3s:pssv    husband    with    3p:nfut-die  
           the woman and her husband died

## (c.3) VERB WITH LOCUS AND CONCOMITANT

This is the only combination of actants not represented in the texts. Since constituents of both types occur independently of each other and of the Patient, it seems likely that this gap is merely due to sampling error rather than to a restriction against this combination of actants occurring without a Patient. The validity of this assumption could easily be tested in a field situation.

## (d) VERB WITH THREE NOMINAL CONSTITUENTS

4869      mani    koloaka    ang    ama-gagana    sa-gu                    aanana            ua  
 49a      lpE    shellfish    loc    lpE:fut-go    thing-ls:pssv    slave/child with  
           we others, I and my slave girls, are going to get shellfish  
           (we are going to the place of the shellfish, with my slaves)

In contrast with sentence 3259 (c.2), this sentence demonstrates that the Concomitant actant is syntactically separate from the Patient. In 3259, *batafa sana kanega* could be analysed alternatively as an alienable possessive construction, and therefore as a single constituent, rather than as two separate actants.

Wheeler's texts do not contain examples of each intransitive verb occurring with all possible combinations of the three case relations under discussion. This fact does not constitute sufficient grounds, however, for claiming that certain verbs cannot occur with actants in certain case relations. Such a claim could be supported only after considerable testing of combinations of constituents with a native speaker.

As a working hypothesis it will be assumed that all intransitive verbs can occur with any combination of actants in the three case relations mentioned above. Refinements of this admittedly crude hypothesis can be made in consultation with a native speaker.

## 5.3.2.2 Case marking

## (a) LOCUS, [+LOC]

Actants in the Locus case relation carry the case relation feature [+LOC] and the locative case form feature [+L]. Markers of the locative case form are the postpositions *ang* and *a at, in, to*, the preposition *tiga from*, and the nouns *fina where* and *nai here*. All of these forms carry the case form feature [+L].

(a.1) *ang, a at, in, to*

Both *a* and *ang* denote location *at, in, or to* the noun which follows, depending on the meaning of the associated noun and verb. With verbs of motion, *ang* and *a* indicate movement *toward* or *nearby* the entity named by the associated noun. With stative or activity verbs, they denote location *at, or in* the entity named by the associated noun.

Since these postpositions convey both the meanings *toward* and *at*, they carry the semantic feature [-src] (non-source) which indicates that the associated Locus noun is not the source of the action or event described by the verb. *ang* occurs with nouns which end in *a*. *a* occurs in all other situations.

*a at*

3850        *i-suele        sape a*  
39a        *3s:nfut-sleep bed loc*  
             *he slept on a bed*

*a to, toward*

2924        *i-gagana        keno a*  
25a        *3s:nfut-go sea loc*  
             *he went to the sea*

*ang to, toward*

3268        *i-gagana        saiga ang*  
33a        *3s:nfut-go garden loc*  
             *he went to the garden*

(a.2) *tiga from*

Since the preposition *tiga* indicates motion *from* the entity named by the noun it precedes, it carries the semantic feature [+src] (source). This indicates that the action or event described by the verb originates at the place specified by the noun following *tiga*.

166        *magota        i-gagana        ma tiga aba*  
2b        *old:woman 3s:nfut-go dir from bush*  
             *the old woman went there (to the gardens) from the bush*  
             (Wheeler's parenthetical note is not expressed in the  
             Mono-Alu sentence.)

(a.3) *fina where?*

The interrogative pronoun *fina* indicates an undetermined location, and is most often translated with the English interrogative pronoun *where*. The form does not indicate a distinction between source and non-source locations.

1179        *fina        emia-gagana*  
9k        *where 2p:fut-go*  
             *whither are you going*

6356      tiga fina i-ua                      ma  
 66u      from where 3s:nfut-go/come dir  
           whence has he come

Nor is this form restricted to occurrence with verbs of motion or location.

4509      batafa tiga fina i-areai  
 46a      woman from where 3s:nfut-speak  
           where did the woman speak from

(a.4) nai here, there

The noun nai indicates a location, probably a specific one, known to the speaker.

2308      mafa nai fana-kato  
 18c      ls here ls:fut-cast:fish net  
           I am going to put it (the fish net) here

3045      maito nai ona-gagana  
 28c      2s there 2s:fut-go  
           do thou go thither

(b) CONCOMITANT [+CON]

Actants in the Concomitant case relation carry the case relation feature [+CON] and the comitative case form feature [+CM]. The postposition ua is the marker of the comitative case form.

6228      magota fabiu-na                      ua iri-gagana  
 66e      old:woman grandchild-3s:pssv with 3p:nfut-go  
           the old woman and her grandchild went there

(c) PATIENT [+PAT]

As defined above in section 5.1.3, an intransitive verb is any verb which requires that its actant in the Patient case relation be realised by the nominative case form. The initial assumption in this analysis will be that any syntactic markers peculiar to the Patient in intransitive sentences can be taken to be markers of the nominative case form. Refinements to this assumption will be necessary when more complex sentence types are considered, but this hypothesis provides a convenient point of departure into the analysis of case marking in Mono-Alu.

Three syntactic devices figure in the marking of the Patient case relation in Mono-Alu intransitive sentences. These markers include: (1) agreement in person and number with verb prefixes, (2) possibly word order, and (3) marking by the preposition ga.

In intransitive sentences the Patient agrees in person and number with the verb prefix, regardless of word order or other syntactic marking.

This statement is accurate in all situations except one. When a Concomitant actant is present, the verb prefix is plural, indicating that the Patient and the Concomitant actant are participating together in the situation described by the verb. This fact suggests that the Patient and Concomitant actant may form a larger single constituent, perhaps in the Patient case relation, with which the verb prefix must agree. This possibility would be supported by sentences such as 3259 and 6228, above, where the two constituents occur together.



(c.1.4)

2022 mani sa-gu tala ua nife sa-na  
 lpE thing-1s:pssv men with snake thing-3s:pssv  
 famata ang ami-gagana  
 village loc lpE:nfut-go  
 I and my men are going to the snake's abode

(c.1.5)

4869 mani koloaka ang ama-gagana sa-gu  
 49a lpE shellfish loc lpE:fut-go thing-1s:pssv  
 aanana ua  
 child/slave with  
 we others, I and my slave girls, are going to get shellfish

(c.1.6)

2180 ea lalaafa sa-na talaiva ua  
 17b det chief thing-3s:pssv women with  
 iri-fotu ma tiga saiga  
 ep:nfut-go:down dir from garden  
 the chief and his wives came home from the garden

These sentences and the substantial number of others of the same form represent a significant and reasonably consistent pattern in the syntactic structure of Mono-Alu intransitive sentences. When the Patient precedes the verb is occurs sentence initially, and agrees in person and number with the verb prefix. From this pattern it can be concluded that both verb prefix agreement and occurrence in sentence initial position are likely to be markers of the nominative, [+NM], case form. As will be seen below in the discussion of type (c.2) sentences, alteration of this word order requires the use of an additional syntactic marker.

These sentence types also show that the position of the Locus and Concomitant actants with respect to each other and with respect to the verb and Patient is quite flexible, provided that the Patient remains in sentence initial position.

(c.2) V ga PAT

In this construction and its variants, the Patient agrees in person and number with the verb prefix as is the case in type (c.1) constructions. Type (c.2) constructions differ from (c.1) in that the Patient follows the verb and is preceded by the morpheme ga. Variations on this pattern, as represented by the examples in Wheeler's texts, involve variations in the position and presence of actants in the Locus and Concomitant case relations.

(c.2.1) V ga PAT CON

(c.2.2) V ga PAT LOC

(c.2.3) V LOC ga PAT

Or in summary,

V (LOC) ga PAT (CON) (LOC)

again, allowing only one actant in each case relation to occur in a single sentence. Following are examples of each sentence type.

(c.2)

5367 i-tafo ga Tunupa  
 54a 3s:nfut-mourn abs Tunupa  
 Tunupa mourned

- (c.2.1)  
 3466 iri-sae-male ga lalaafa sa-na talaiva ua  
 35a 3p:nfut-go:up-again abs chief thing-3s:pssv woman with  
*the chief and his wives again went up (to the gardens)*  
*(to the gardens is not expressed in the Mono-Alu sentence)*
- (c.2.2)  
 1058 i-safili ga lalaafa kalofa a  
 9b 3s:nfut-come:out abs chief meeting.house loc  
*the chief came out to the meeting house*
- (c.2.3)  
 1740 iri-lefe ma famata ang ga aanana  
 15b 3p:nfut-return dir village loc abs children  
*the children went back to the village*

These examples provide a basis for some conclusions about the syntactic structure of this sentence type:

- (1) ga and the Patient form a single syntactic unit, separate from the verb as well as other nominal constituents. This is demonstrated by the fact that (a) ga PAT occurs independently of both the Locus and Concomitant actants, (b) ga is never separated from the Patient by another constituent, and (c) ga need not immediately follow the verb, but can be separated from the verb by another constituent.
- (2) Though certain exceptions will be mentioned below, in the majority of cases where the Patient follows the verb, it is marked by ga. When the Patient precedes the verb it is marked only by verb prefix agreement.
- (3) The fact that ga is always associated with a noun phrase, and that it precedes that noun phrase, suggests that it should be treated as a preposition.
- (4) Since ga is associated with the Patient in intransitive sentences, it can be considered to be a marker of the nominative case form which is used together with verb prefix agreement when PAT V word order (c.1) is altered. When more complex sentence types are added to the analysis, the function of ga will be expanded somewhat, but its status as a marker of the Patient case relation as proposed here will not be contradicted.

As with type (c.1) sentences, the position of the Locus and Concomitant actants is quite flexible. The (c.2) sentences appear to suggest that the verb is always sentence initial since Locus and Concomitant actants never precede it. This apparent pattern may be due in part to accidental gaps in the sample, because there is a substantial number of Patient-less intransitive sentences in which a Locus actant precedes the verb. For example:

1179 fina emia-gagana  
 9k where 2p:fut-go  
*whither are you going*

This pattern is much less common than the opposite order, where the Locus follows the verb in Patient-less intransitive sentences. Of the 261 sentences which contain only a Locus and a verb, 246 are of the form V LOC, while only 15 are of the form LOC V.

As already mentioned, the dominant pattern represented by type (c.1) and (c.2) sentences is not perfectly consistent.

Of the 519 intransitive sentences containing at least a verb and Patient, and at most a verb, Patient, Locus, and Concomitant actant, four of them are of the form shown in type (c.3)

(c.3) PAT ga V

- 1099 fafine-ng ga i-belu  
 9d brother-2s:pssv abs 3s:nfut-hungry  
*your brother is hungry*
- 1220 pirite ga i-gagana  
 9n pirate:bird abs 3s:nfut-go  
*the pirate bird went off*
- 3653 tiong ga kalofa a ena-safili  
 36c man abs meeting:house loc 3s:fut-exit  
*a man will leave the meeting house*
- 5135 eang ga ena-anee  
 51b this abs 3s:fut-climb  
*let this one go up*

While these sentences are consistent with the above stated views that (a) the Patient is sentence initial when it precedes an intransitive verb, and (b) that ga is always associated with the Patient constituent, they are not compatible with the proposal that ga is a preposition.

Unfortunately, no explanation for this variation in word order appears to be at hand. However, since this pattern is represented by a very small number of cases, this analysis will proceed on the initially proposed hypothesis in hopes that an explanation for these sentences can be found at a later time.

A possible explanation for the word order in sentence 3653 might be that the verb is not intransitive, and that kalofa rather than tiong is the Patient. This would explain the position of ga with respect to the noun phrase, but not with respect to the verb. A problem with this analysis, though, is that kalofa would then be associated with two case markers, the preposition ga, and the locative postposition a.

Another construction type which does not fit in with the dominant pattern represented by types (c.1) and (c.2) is type (c.4).

(c.4) V PAT

Here, the Patient follows the verb and is not marked by ga as is normally the case in type (c.2).

(c.4)

- 5897 i-gumo kiniu  
 64b 3s:nfut-capsize canoe  
*the canoe capsized*

(c.4.1)

- 5901 iri-soku fanua famata ang  
 64c 3p:nfut-arrive men village loc  
*the men got home*

(c.4.2)

- 3454 iri-gagana saiga ang lalaafa sa-na talaiva ua  
 35a 3p:nfut-go garden loc chief thing-3s:pssv women with  
*the chief and his wives went to the garden*

Forty (less than eight per cent) of the 519 intransitive sentences are of this form. Some of these can be explained by the fact that the boundaries between sentences are in many cases uncertain. Sentence boundaries involving these forms could be justifiably altered in several cases, thereby yielding the expected word order.

Other explanations are also possible. For example, in 3454, *lalaafa*, which I have analysed as the Patient, could be analysed equally well as the nominal possessor in an alienable possessive construction, and thus would be part of the Concomitant actant. A more appropriate gloss for such an analysis would be *they went to the garden with the chief's wives*.

### 5.3.2.3 Summary

The above sections have proposed an analysis of intransitive sentences in Mono-Alu. The discussion has been concerned primarily with the case relations of nominal constituents in intransitive sentences, and the relationships among case relations, case forms, and case markers. The major hypotheses proposed above are summarised in the following list.

- (1) Subject to omission of the Patient due to ellipsis, intransitive sentences consist minimally of an inflected verb and Patient, and maximally of an inflected verb with Patient, Locus, and Concomitant actants.
- (2) The Locus case relation [+LOC] is realised by the locative case form [+L] which is marked by the postpositions *a* and *ang*, the preposition *tiga*, and the nouns *fina* and *nai*.
- (3) The Concomitant case relation [+CON] is realised by the comitative case form [+CM] and is marked by the postposition *ua*.
- (4) The Patient case relation [+PAT] is realised by the nominative case form [+NM] which is always marked by (a) verb prefix agreement, in addition to (b) occurrence in sentence initial position if preceding the verb, and (c) marking by the preposition *ga* when following the verb.
- (5) The fact that two sentence types contradict the case marking pattern noted in (4) for the Patient case relation has been acknowledged. However, since the contradictory examples are in a considerable minority the decision has been made to maintain the initial hypothesis summarised in (4) in hopes that a satisfactory explanation can later be found for the aberrant constructions.
- (6) Variation from PAT V order requires that the Patient be marked by the preposition *ga*.

## 5.3.3 Transitive constructions

### 5.3.3.0 Introduction

The fundamental elements of an intransitive sentence are the verb and its obligatory nominal argument. By definition in a lexicase grammar, all verbs (except meteorological ones in some languages) require a Patient actant in their case frames. Thus the obligatory nominal argument of an intransitive verb is defined as the Patient.



It is assumed that actants in the Patient case relation in intransitive sentences are realised by the nominative case form. Thus it is likely that some or all of the syntactic markers associated with the actant in the Patient case relation in intransitive sentences are markers of the nominative case form.

In section 5.3.2 it was shown that the Patient in intransitive sentences agrees with the verb prefix, and that it is consistently associated with the preposition *ga* when following the verb. Taking a relatively unbiased point of view, and without considering other construction types, the patterns observed with regard to prefix agreement, *ga* marking, and the Patient case relation could be accurately interpreted in any of the following ways:

(a) Both prefix agreement and *ga* are markers of the nominative case form. This is the point of view proposed in the summary of section 5.2, and follows from the assumption that intransitive Patients are nominative, and the observation that prefix agreement and *ga* are associated with the Patient in intransitive sentences. This pattern does not, however, rule out the possibility that the nominative case form may also realise other case relations in other sentence types. That is, these sentences do not demonstrate that *ga* and prefix agreement are always associated with the actant in the Patient case relation.

(b) Both prefix agreement and *ga* are consistently associated with the actant in the Patient case relation. This would mean that the Patient is always realised by the same case form, and that these two case markers mark only one case form which realises only one case relation, the Patient.

(c) Prefix agreement and *ga* are markers of different case forms which, in intransitive sentences, coincide and realise the Patient case relation. This alternative allows a single case relation to be realised simultaneously by two case forms.

Intransitive sentences alone do not provide enough information to determine which of these alternatives is correct. An investigation of the distribution of prefix agreement and *ga* marking in transitive sentences will make a decision possible. The primary objectives of section 5.3.3 are: (1) to establish that the verb suffixes *i* and *ng*, which Wheeler analyses as third person singular object markers, are actually transitive suffixes, and therefore that the third person singular agreement suffix is zero, (2) to determine the case marking function of verb prefix agreement, verb suffix agreement, and marking by the preposition *ga* in transitive sentences, (3) to show that the distribution of *ga* and prefix agreement are in fact distinct, and that they are markers of different case forms which coincide in intransitive sentences when they both realise the same case relation (alternative (c) above), and (4) to determine what case markers are associated with constituents in the Agent, Correspondent, and Patient case relations.

### 5.3.3.1 Transitive suffixes

There are two types of transitive verbs represented in Wheeler's texts: (1) those which consist of (a) a person-marking verb prefix, (b) the verb stem, (c) a transitive suffix (either *i* or *ng*), and (d) a person-marking suffix, and (2) those verbs which consist of all the elements of (1) except the transitive suffix. These two types are summarised in the following formulas, and exemplified in Figure 9.

- I:        pfx-V-  $\left\{ \begin{array}{l} i \\ ng \end{array} \right\}$  -sfx  
 II:        pfx-V-  $\emptyset$  -sfx

The suffixes *i* and *ng* were analysed by Wheeler as third person singular object suffixes. His analysis, however, makes it difficult if not impossible to account for at least two characteristics of transitive constructions: (1) *i* and *ng* (in its phonologically altered form *n*) occur not only with third person singular Patients (objects), but also with Patient objects of all other persons and numbers (see Figure 9), and (2) some transitive verbs with third person singular Patient objects carry a third person singular object suffix, as analysed by Wheeler, (Type I, Figure 9), but others do not (Type II, Figure 9).

Both of these characteristics can be accounted for by hypothesising that *i* and *ng* are transitive suffixes and that the third person singular agreement suffix is zero ( $\emptyset$ ). This hypothesis will be assumed to be correct in the following analysis of transitive constructions.

PERSON PREFIX	VERB	TRANS. SUFFIX	PERSON SUFFIX	GLOSS
Type I: (a)				
ona	eba	<i>i</i>	afa	<i>you will marry me</i>
fana	eba	<i>i</i>	o	<i>I will marry you</i>
<i>i</i>	eba	<i>i</i>	$\emptyset$	<i>3s married 3s</i>
<i>i</i>	ora	<i>i</i>	ita	<i>3s has tricked us</i>
ena	eba	<i>i</i>	ami	<i>3s will marry us(excl)</i>
fana	eba	<i>i</i>	ang	<i>I will marry you(pl)</i>
<i>i</i>	eba	<i>i</i>	ri	<i>3s will marry them</i>
(b)				
<i>i</i>	sali	<i>n</i>	afa	<i>3s spoke to me</i>
fai	sali	<i>n</i>	o	<i>I told you</i>
emia	ela	<i>ng</i>	$\emptyset$	<i>you will sing to 3s</i>
iri	sali	<i>ng</i>	$\emptyset$	<i>they spoke to 3s</i>
iri	sali-male	<i>ng</i>	$\emptyset$	<i>they spoke again to 3s</i>
fana	sali	<i>n</i>	ri	<i>I will tell them</i>
Note also the intransitive:				
<i>i</i>	salisali	$\emptyset$	$\emptyset$	<i>it spoke forth</i>
Type II:				
ona	selo	$\emptyset$	afa	<i>you will boil me</i>
fana	lapu	$\emptyset$	o	<i>I will kill you</i>
fana	lapu	$\emptyset$	$\emptyset$	<i>I will kill 3s</i>
ena	lapu	$\emptyset$	ita	<i>3s will kill us(incl)</i>
ena	lapu	$\emptyset$	ami	<i>3s will kill us(excl)</i>
ama	lapu	$\emptyset$	ang	<i>we(incl) will kill you(pl)</i>
<i>i</i>	tupa	$\emptyset$	ri	<i>3s fed them</i>

Figure 9: Transitive verbs, with and without transitive suffixes<sup>7a</sup>

### 5.3.3.2 Transitive constructions

#### 5.3.3.2.0 Introduction

This section will be concerned with verbs which require two nominal constituents in their case frames. One must be either an Agent or Correspondent, and the other must be a Patient.

With regard to case marking it will be concluded that (1) verb prefix agreement marks the nominative case form which realises the Agent and Correspondent case relations, (2) *ga* marks the absolutive case form which realises the Patient case relation, and (3) verb suffix agreement marks the accusative case form which realises the Patient case relation. Before discussing the constructions which provide evidence for these conclusions it will be useful to define some terms in order to avoid any confusion over terminology.

##### 5.3.3.2.0.1 Terminology

The distinction between transitive verbs and intransitive verbs used in this section will follow Kullavanijaya's definition as given in section 5.1.

It will be necessary to briefly consider the distinction between an accusative case marking system and an ergative case marking system.

As traditionally defined, an accusative case marking system has the following characteristics: (1) subjects of transitive and intransitive verbs are marked identically by a nominative case marker, and (2) objects of transitive verbs are marked distinctly by an accusative marker.

An ergative case marking system, on the other hand, has been defined as a system in which (1) subjects of intransitive verbs and objects of transitive verbs are marked identically by an absolutive (also called nominative (Hockett 1958:235)) case marker, and (2) subjects of transitive verbs are marked uniquely by an ergative case marker.

In order to avoid possible confusion by defining these two case marking systems in terms of the traditional notions of subject, object, and transitivity, for the purposes of this study they will be redefined, equivalently, in terms of case relations and case forms.

In an accusative case marking system, the protagonist (definition section 5.1), regardless of its case relation (Agent, Correspondent, or Patient) is realised by the nominative case form. In an ergative case marking system, the Patient is always realised by a single case form, the absolutive. In a purely ergative system, where there is no possibility of confusion, the absolutive case form is sometimes referred to as nominative. When this situation applies, the two systems can be distinguished by the ordering of case relations in the subject choice hierarchy. That is, they are distinguished by which case relation has priority in being realised by the nominative case form.

In this discussion, the terms nominative and absolutive will be kept distinct, nominative being a case marker whose distribution is characteristic of an accusative case marking system, and absolutive being a case marker whose distribution is characteristic of an ergative case marking system.

### 5.3.3.2.1 Case marking and word order in transitive sentences

This section is concerned with three interrelated issues: (1) the order of constituents in transitive sentences, (2) the case marking function of *ga* in transitive sentences, and (3) the case marking function of affix agreement in transitive sentences. Under ideal circumstances, working with all the crucial pieces of data, it would be possible to discuss all of these issues simultaneously. This would make it possible to clearly see the relationships among all three of these components of Mono-Alu grammar.

The available data for Mono-Alu is unfortunately fragmentary, however, so these issues must necessarily be discussed in isolation from each other to some extent. There will be enough overlap in the discussions, however, to see how the fragments fit into a larger picture of the complete case marking system.

Two consistent patterns with regard to word order were observed in intransitive sentences: (1) when the Patient actant follows the verb it is marked by *ga*, and when it precedes the verb it is not; (2) when preceding the verb, the Patient most often occurs in sentence initial position. It was also observed that the position of other nominal constituents is quite free as long as these two patterns are not violated.

The distribution of *ga* with respect to the Patient as observed in intransitive sentences also carries over into transitive constructions. The Patient does not, however, always occur sentence initially when preceding the verb in transitive sentences. Transitive sentences which contain either an Agent or Correspondent are of the following types.

- (a)       $\left\{ \begin{array}{l} \text{AGT} \\ \text{COR} \end{array} \right\}$                   v                  ga      PAT
- (b)                                  v       $\left\{ \begin{array}{l} \text{AGT} \\ \text{COR} \end{array} \right\}$       ga      PAT
- (c)                                  v                  ga      PAT       $\left\{ \begin{array}{l} \text{AGT} \\ \text{COR} \end{array} \right\}$

When the Patient occurs to the left of the verb, it is not marked by *ga*:

- (d)       $\left\{ \begin{array}{l} \text{AGT} \\ \text{COR} \end{array} \right\}$       PAT      v
- (e)                                  PAT      v       $\left\{ \begin{array}{l} \text{AGT} \\ \text{COR} \end{array} \right\}$
- (f)                  PAT       $\left\{ \begin{array}{l} \text{AGT} \\ \text{COR} \end{array} \right\}$       v

As in intransitive sentences, one or both of the syntactically obligatory constituents can be elliptically omitted. Such elliptical sentences are very common in the texts.

- (g) [abc.1]                          v                  ga      PAT
- (h) [def.1]                          PAT      v
- (i) [adf.2]                           $\left\{ \begin{array}{l} \text{AGT} \\ \text{COR} \end{array} \right\}$       v
- (j) [bce.2]                          v       $\left\{ \begin{array}{l} \text{AGT} \\ \text{COR} \end{array} \right\}$
- (k) [abcdef.3]                          v

Following are examples of sentence types (a), (b), and (c). In these sentences, the distribution of verb prefix agreement and marking by the preposition *ga* are especially important.

Type (a):

- 928 mafa fana-roro-i-∅ ama ga mamaifa  
 8g 1s 1s:fut-see-tr-3s dir abs *chiefly:woman*  
 COR PAT  
*I will look at the chiefly woman*
- 214 maito tibo-ng oi-aang-∅-∅ ga kokong  
 2f 2s self-2s:pssv 2s:nfut-eat-tr-3s abs *taro*  
 AGT PAT  
*thou thyself didst eat the taro*
- 4704 mafa boi tapoina fana-too-i-ri ga aabaisa  
 48b 1s day many 1s:fut-follow-tr-3p abs *girls*  
 AGT PAT  
*every day when I go to where the girls are*  
*(every day I will follow the girls)*
- 698 mafa fai-lapu-lapu-∅-ri ita ga episa  
 7c 1s 1s:nfut-kill-kill-tr-3p ? abs *three*  
 AGT  
*I have killed three*
- 1286 ea magota bau ena-lapu-∅-ri ga  
 9t det *old:woman* neg 3s:fut-kill-tr-3p abs  
 AGT  
 sa-gu talaiva  
*thing-1s:pssv women*  
 PAT  
*the old woman shall not kill my wives*

Type (b):

- 5046 i-nkot-i-∅ Matairua ga tauii  
 50e 3s:nfut-grasp-tr-3s Matairua abs *child*  
 AGT PAT  
*Matairua took hold of the child*
- 174 i-aang-∅-∅ boo ga kokong  
 2c 3s:nfut-eat-tr-3s pig abs *taro*  
 AGT PAT  
*a pig has eaten the taro*

Type (c):

- 1455 iri-bubutu-i-∅ ga boo auau  
 12b 3p:nfut-attack-tr-3s abs pig dog  
 PAT AGT  
*the dogs attacked the pig*
- 3300 iri-iole-∅-∅ ga boo nka-na apa-na batafa  
 33c 3p:nfut-call-tr-3s abs pig mother-3s:pssv father-3s:pssv woman  
 PAT AGT AGT  
*the woman's mother and father called to the pig*

6792	i-toka- $\emptyset$ - $\emptyset$	ga	atele	Ongoo
67aa	3s:nfut-follow/meet-tr-3s	abs	river	Ongoo
		PAT	AGT	

*Ongoo went to a river*

Two characteristics of construction types (a), (b), and (c) are of immediate concern with regard to case marking: (1) verb prefix agreement, and (2) marking by the preposition ga.

These sentences show that regardless of word order, the verb prefix agrees in person and number with the Agent or Correspondent, and that when the Patient follows the verb it is marked by ga. These circumstances differ significantly from the intransitive sentences in section 5.3.2. There, ga and prefix agreement were both associated with the same nominal constituent. Here, they are associated with different nominal constituents. One marks the Agent or Correspondent; the other marks the Patient.

The intransitive sentences together with these show that the distribution of verb prefix agreement follows the pattern of a marker of the nominative case form in an accusative case marking system. That is, Agents and Correspondents in transitive sentences and Patients in intransitive sentences are realised by the same case form, most commonly called nominative. Thus verb prefix agreement is Mono-Alu's marker of the nominative case form.

The preposition ga, on the other hand, is associated with the Patient in both intransitive sentences and transitive sentences. Regardless of whether the verb is transitive or intransitive, the Patient is associated with ga. The distribution of ga in transitive and intransitive sentences thus shows that the distribution of ga follows the pattern of a marker of the absolutive case form in an ergative case marking system. That is, the Patient is always realised by the same case form, most commonly called absolutive. Thus ga is Mono-Alu's marker of the absolutive case form, and is lexically marked with the feature [+AB].

In sentence types (d), (e), and (f) ga does not appear because the Patient precedes the verb. Notice, however, the distribution of verb prefix and suffix agreement.

Type (d):

2374	nitu	tióng	rekona	ena-roro-i- $\emptyset$	
19a	ghost	man	good:one	3s:fut-see-tr-3s	
	COR	PAT			
	<i>if the ghost sees a goodly man</i>				
	<i>(the ghost will see a goodly man)</i>				
1827	maito	kai-gu		oi-golu- $\emptyset$ - $\emptyset$	
15e	2s	brother-1s:pssv	2s:nfut-eat-tr-3s		
	AGT	PAT			
	<i>you swallowed my brother</i>				
3663	maito	sa-n	tala	rarami	iri-faio- $\emptyset$ - $\emptyset$
36d	2s	thing-2s:pssv	people	food	3p:nfut-put-tr-3s
		AGT		PAT	
	kalofó	a			
	meeting:house	loc			
	LOC				
	<i>your people have put food in the meeting house</i>				

1949 maang boo lafulu emia-gagana emia-galo-Ø-ri ma  
 16e 2p pig ten 2p:nfut-go 2p:fut-carry-tr-3p dir  
 AGT PAT  
*do ye go and bring back ten pigs*

## Type (e):

1285 eang talaiva elua ma-mamaifa  
 9t det women two pl-chiefly:woman  
 PAT

i-eba-i-ri lalaafa  
 3s:nfut-marry-tr-3p chief  
 AGT

*the chief married the two women, chiefly women*

2377 batafa rekona ena-roro-i-Ø nitu  
 19a woman good:one 3s:fut-see-tr-3s ghost  
 PAT COR

*if the ghost sees a comely woman  
 (the ghost will see a comely woman)*

171 kokong i-aang-Ø-Ø boo  
 2c taro 3s:nfut-eat-tr-3s pig  
 PAT AGT

*a pig has eaten the taro*

1523 e-ng kokong i-aang-Ø-Ø fafine-ng  
 13b thing-2s:pssv taro 3s:nfut-eat-tr-3s brother-2s:pssv  
 PAT AGT

*your brother has eaten your taro*

1831 mafa kai-gu i-lapu-Ø-Ø sa-ma tolool  
 15e ls brother-ls:pssv 3s:nfut-kill-tr-3s thing-lpE:pssv eel  
 PAT AGT

*our eel has slain my brother*

## Type (f):

5563 natu-gu tiong i-roro-i-Ø  
 57b daughter-ls:pssv man 3s:nfut-see-tr-3s  
 PAT COR

*a man has seen my daughter*

4756 mani nka-ng bau ena-lapu-Ø-ami  
 48f lpE mother-2s:pssv neg 3s:fut-kill/hit-tr-lpE  
 PAT AGT

*we hope your mother will not beat us*

3523 maita iva lauma ena-lapu-lapu-Ø-ita lalaafa  
 35e lpI now then 3s:fut-kill-kill-tr-lpI chief  
 PAT AGT

*now (then,) the chief will kill us*

5282 sa-ra beampeu tiong i-lapu-Ø-Ø  
 52k thing-lpI:pssv thing man 3s:nfut-kill-tr-3s  
 PAT AGT

*some man has killed our possession*

4560	mani	suma	i-gasu-∅-ami	ma
46e	lpE	bone	3s:nfut-drive:away-tr-lpE	dir
	PAT	AGT		
	<i>the bones have driven us away</i>			
2461	mafa	natu-gu	i-mera-i-afa	ma
20e	ls	child-ls:pssv	3s:nfut-bring-tr-ls	dir
	PAT	AGT		
	<i>my child brought me</i>			

These sentences provide additional evidence which shows that verb prefixes agree with actants in the Agent and Correspondent case relations, and thus that verb prefix agreement is a marker of the nominative case form. Sentences of types (a)-(f) which have suffixes other than third person singular also show that the suffixes agree in person and number with actants in the Patient case relation. Since suffixes agree with Patients in transitive sentences, they function as markers of the accusative case form.

Sentences of type (g) provide additional evidence which supports the hypothesis that verb suffixes agree with Patients in transitive sentences and that verb suffix agreement is therefore a marker of the accusative case form. These sentences also show how verb suffix agreement is related to ga marking.

Type (g):

1273	i-roro-i-ri	ga	la-iloa-na	
9t	3s:nfut-see-tr-3p	abs	pl-co-wife-3s:pssv	
			PAT	
	<i>she saw her fellow wives</i>			
3533	i-kafuru-n-ri	ga	la-iloa-na	
35f	3s:nfut-angry-tr-3p	abs	pl-co-wife-3s:pssv	
			PAT	
	<i>she got wrath with (her) fellow wives</i>			
2594	fana-lapu-∅-ri	ga	aanana	
21h	ls:fut-kill-tr-3p	abs	children	
			PAT	
	<i>I am going to kill the children</i>			
1810	i-lapu-∅-∅	ga	tiong	
15d	3s:nfut-kill-tr-3s	abs	man	
			PAT	
	<i>he killed the man</i>			
958	i-gasu-gasu-∅-ri	ga	sa-na	to-toniga
8k	3s:nfut-drive:away-drive:away-tr-3p	abs	thing	pl-slave
			PAT	
	<i>she sent off her slave girls</i>			
1903	i-toka-∅-ri	ga	sa-na	tala
16b	3s:nfut-follow-tr-3p	abs	thing-3s:pssv	men
			PAT	
	<i>he followed his men</i>			
2677	ona-galo-∅-ri	ma	ga	aanana
21o	2s:fut-carry-tr-3p	dir	abs	children
			PAT	
	<i>(you) bring me back children</i>			



5446	iri-galo-∅-∅	ma	ga	fili
54f	3p:nfut-carry-tr-3s	dir	abs	rope
				PAT
	<i>they brought a rope</i>			
728	i-ora-i-ri	ga	sibubuum	apaapa
7e	3s:nfut-lie-tr-3p	abs	wasp	frog
			PAT	PAT
	<i>he tricked the wasp and frog</i>			
1845	i-ora-i-∅	ga	toloo	
15f	3s:nfut-lie-tr-3s	abs	eel	
			PAT	
	<i>he was tricking the eel</i>			
6351	re-soku-i-ri	ga	la-nka-ria	
66t	3p:nfut-arrive-tr-3p	abs	pl-mother-3p:pssv	
			PAT	
	<i>they reached their mothers</i>			
6671	i-soku-i-∅	ga	fafine-na	
67r	3s:nfut-arrive-tr-3s	abs	brother-3s:pssv	
			PAT	
	<i>she reached her brother</i>			
1280	i-sali-n-ri	ga	la-loa-na	
9t	3s:nfut-speak-tr-3p	abs	pl-father-in-law-3s:pssv	
			PAT	
	<i>he spoke to his fathers-in-law</i>			
6379	iri-sali-ng-∅	ga	Bego	
66x	3p:nfut-speak-tr-3s	abs	Bego	
			PAT	
	<i>they said to Bego</i>			

These sentences (especially those with plural Patients) exhibit an important case marking function of both verb suffix agreement and marking by the preposition *ga*. Both verb suffix agreement and *ga* are associated with actants in the Patient case relation. The pattern is also exhibited by type (a) sentences.

Though suffix agreement and *ga* marking are both associated with the Patient in transitive sentences, the overall distributions of the two case markers differ significantly. The preposition *ga* is associated with the Patient in both transitive and intransitive constructions. Thus its distribution is characteristic of a marker of the absolutive case form as defined in 5.3.3.2.0.1. In contrast to this distribution, verb agreement suffixes occur only in transitive constructions, where they are also associated with the actant in the Patient case relation. This distribution is characteristic of a marker of the accusative case form as defined in the same section.

In sentence type (h) the Patient occurs to the left of the verb, so these sentences indicate little about the distribution or function of *ga* marking. They do, however, show that verb suffixes agree with Patients in transitive sentences, and therefore that verb suffix agreement is Mono-Alu's marker of the accusative case form.

## Type (h) :

- 917 maito ena-roro-i-o  
8f 2s 3s:fut-see-tr-2s  
PAT  
*if she sees you*  
*(she will see you)*
- 5426 fanua ea latu i-lapu-Ø-ri  
54e men det hundred 3s:nfut-kill-tr-3p  
PAT  
*he killed one hundred men*
- 5850 iana ena-lapu-Ø-Ø  
63a fish 3s:fut-kill-tr-3s  
PAT  
*he would catch fish*
- 2322 mafa ona-faio-Ø-afa tatai a  
18d ls 2s:fut-put-tr-ls dung loc  
PAT  
*put me down on the dung (said by a louse)*
- 1397 mafa oi-ora-i-afa elea boi  
11c ls 2s:lie-tr-ls one day  
PAT  
*once you tricked me*
- 2561 maita i-ora-i-ita  
21f lpI 3s:nfut-lie-tr-lpI  
PAT  
*he has tricked us*

Sentence types (i) and (j) contain only Agents and Correspondents, since the Patient actants have been elliptically omitted.

## Type (i) :

- 3116 natu-ria i-non-i-ri ma  
29e son-3p:pssv 3s:nfut-hear-tr-3p dir  
COR  
  
tiga peta olova-na ang  
*from ground inside-3s:pssv loc*  
LOC  
*their son heard them from below the ground*
- 2345 maito oi-ora-i-afa  
18e 2s 2s:nfut-lie-tr-ls  
AGT  
*you have tricked me*
- 1209 fabiu-m ena-eba-i-ami  
9n grandson-2s:pssv 3s:fut-marry-i-tr-lpE  
AGT  
*your grandson is to marry us*
- 6116 baoi iri-lau-i-Ø  
65r shark 3p:nfut-go-tr-3s  
AGT  
*the sharks came up to him*

Type (j):

2273	i-non-i-ri	nitu	
18a	3s:nfut- <i>hear</i> -tr-3p	<i>ghost</i>	COR
		<i>the ghost heard them</i>	
5329	i-non-i-∅	tiong	
53a	3s:nfut- <i>hear</i> -tr-3s	<i>man</i>	COR
		<i>a man heard her</i>	
745	i-ora-i-ami	Sakusaku	
7f	3s:nfut- <i>lie</i> -tr-lpE	<i>Sakusaku</i>	AGT
		<i>Sakusaku has tricked us</i>	
4797	i-maula-i-afa	lai-gu	
48h	3s:nfut- <i>hurt</i> -tr-ls	<i>forehead</i> -ls:pssv	AGT
		<i>my forehead is hurting me</i>	
1118	i-sali-ng-∅	nka-na	
9e	3s:nfut- <i>speak</i> -tr-3s	<i>mother</i> -3s:pssv	AGT
		<i>her mother spoke to her</i>	
5823	i-mera-∅-ri	tiong lalaafa	
61c	3s:nfut- <i>bring</i> -tr-3p	<i>man chief</i>	AGT
		<i>the man who was a chief took them with him</i>	

One other type of transitive construction occurs in Wheeler's texts. This is a construction which requires three nominal constituents. Only the verb *tele* occurs in this construction type. *tele* is a Type II transitive verb which does not carry a transitive suffix, but does carry person marking suffixes. Examples follow:

3781	batafa	i-tele-∅-∅	ga	nife	tapoina	rarami
37d	<i>woman</i>	3s:nfut- <i>give</i> -tr-3s	abs	<i>snake</i>	<i>much</i>	<i>food</i>
				<i>the woman gave the snake plenty of food</i>		
3358		i-tele-∅-ri	leako	ga	sa-na	auau
34b		3s:nfut- <i>give</i> -tr-3p	<i>magic</i>	abs	<i>thing</i> -3s:pssv	<i>dog(s)</i>
				<i>he gave his dogs a magic</i>		
1799		tara-tele-∅-∅	rarami	ga	toloo	
15d		lpI:fut- <i>give</i> -tr-3s	<i>food</i>	abs	<i>eel</i>	
				<i>we will give food to the eel</i>		
516		iri-tele-∅-∅	ga	tete-ria		ukala
5c		3p:nfut- <i>give</i> -tr-3s	abs	<i>mother-in-law</i> -3p:pssv		<i>crayfish</i>
				<i>they gave crayfish to their mother-in-law</i>		

Assuming that the verb suffixes and *ga* have the same case marking function in these sentences as they do in other transitive constructions, the verb prefix agrees in person and number with the giver, the receiver is marked by *ga* and verb suffix agreement, and the gift is unmarked. Thus the giver can be analysed as the Agent, and the receiver as the Patient.

The syntactic marking of actants with *tele* is not analogous to the marking of actants with the English verb *give*. The marking is similar, however, to the English verb *present*. For example:

the speaker	presented	the winner	with an award
AGT		PAT	INS

On analogy with this sentence, *tele* will be analysed as a transitive verb which requires an Agent giver, a Patient receiver, and an Instrument gift.

### 5.3.3.2.2 Summary

The analysis of Mono-Alu's case marking system as proposed in section 5.3.2 on intransitive constructions and this section on transitive constructions can be summarised as follows:

(1) Intransitive constructions consist minimally of an inflected verb and actant in the Patient case relation. Transitive constructions consist minimally of an inflected verb, an actant in the Agent or Correspondent case relation, and an actant in the Patient case relation.

(2) Case marking of obligatory constituents in transitive and intransitive sentences is accomplished by (a) verb prefix agreement, (b) verb suffix agreement, and (c) marking by the preposition *ga*.

(3) Verb prefixes agree with the protagonist, that is, with the actant in the Patient case relation in intransitive sentences, and the Agent or Correspondent in transitive sentences. This pattern of distribution is characteristic of a marker of the nominative case form in an accusative case marking system. Therefore, verb prefix agreement is Mono-Alu's marker of the nominative case form which realises the Agent, Correspondent, and Patient case relations.

(4) Verb suffixes occur only in transitive sentences and agree with the actant in the Patient case relation. This pattern of distribution is characteristic of a marker of the accusative case form in an accusative case marking system. Therefore, verb suffix agreement is Mono-Alu's marker of the accusative case form which realises the Patient case relation.

(5) The preposition *ga* occurs in both transitive and intransitive sentences, and is associated with the actant in the Patient case relation in both sentence types. This pattern of distribution is characteristic of a marker of the absolutive case form in an ergative case marking system. Therefore, the preposition *ga* is Mono-Alu's marker of the absolutive case form which realises the Patient case relation.

(6) Points (3), (4), and (5) constitute a hypothesis that Mono-Alu's case marking system exhibits characteristics of both an ergative and an accusative case marking system. Thus it is hypothesised that Mono-Alu's is a mixed accusative-ergative case marking system.

(7) Word order is highly variable, and for this reason will not be considered a case marking device. Some general tendencies in word order can be observed however. In intransitive constructions the orders (a) PAT V (SV), and (b) V PAT (VS) occur with approximately equal frequency. In PAT V order, the Patient is not marked by *ga*. In V PAT order the Patient is marked by *ga*. In transitive sentences, a variety of orders can be observed, though the most frequent are:

- (c)  $\left\{ \begin{array}{l} \text{AGT} \\ \text{COR} \end{array} \right\}$  V PAT (equivalent to SVO)
- (d)  $\left\{ \begin{array}{l} \text{AGT} \\ \text{COR} \end{array} \right\}$  PAT V (equivalent to SOV)

When the Patient follows the verb it is marked by the preposition *ga*. When the Patient precedes the verb it is not.

### 5.3.4 'Semitransitive' constructions

In his work on proto-Oceanic grammar, Pawley discusses a type of construction which exhibits properties of both transitive and intransitive sentences. He calls these 'incorporated object' constructions, and notes that their canonical structure is like that of transitive sentences, but that the verbs carry neither transitive suffixes nor person marking suffixes (Pawley 1978:4.7). Similar constructions occur in Mono-Alu. However, the term 'semitransitive' (Sugita 1973) is more appropriate to Mono-Alu's constructions, because the 'object' nominal is not as closely bound to the verb as are incorporated objects.

The difference between transitive and 'semitransitive' constructions in Mono-Alu is most obvious in sentences with verb bases such as *roro see* which occurs both transitively and intransitively. As a Type I transitive verb, *roro* carries the transitive suffix *i* and a suffix which agrees in person and number with the Patient:

- (a)
- |      |                                     |                          |            |                   |
|------|-------------------------------------|--------------------------|------------|-------------------|
| 5346 | <i>batafa</i>                       | <i>i-roro-i-∅</i>        | <i>ga</i>  | <i>makomako</i>   |
| 53b  | <i>woman</i>                        | <i>3s:nfut-see-tr-3s</i> | <i>abs</i> | <i>mouth:harp</i> |
|      |                                     |                          |            | <i>PAT</i>        |
|      | <i>the woman saw the mouth harp</i> |                          |            |                   |

As an intransitive verb, *roro* is unsuffixed:

- (b)
- |      |                    |            |              |
|------|--------------------|------------|--------------|
| 1472 | <i>i-roro</i>      | <i>ga</i>  | <i>tiong</i> |
| 12c  | <i>3s:nfut-see</i> | <i>abs</i> | <i>man</i>   |
|      |                    |            | <i>PAT</i>   |
|      | <i>the man saw</i> |            |              |

Case marking in (a) and (b) follows the patterns noted in earlier sections for transitive and intransitive sentences. In contrast to these, *roro* also occurs in sentences such as:

- (c)
- |      |                                     |            |                |               |               |
|------|-------------------------------------|------------|----------------|---------------|---------------|
| 3494 | <i>i-roro</i>                       | <i>ga</i>  | <i>lalaafa</i> | <i>batafa</i> | <i>rekona</i> |
| 35c  | <i>3s:nfut-see</i>                  | <i>abs</i> | <i>chief</i>   | <i>woman</i>  | <i>good</i>   |
|      |                                     |            | <i>?COR</i>    | <i>?PAT</i>   |               |
|      | <i>the chief saw a comely woman</i> |            |                |               |               |

Sentence (c) has two nominal constituents which appear to function semantically like those in (a). The distribution of case markers, however, is significantly different in (c). In (a), the verb prefix agrees with the seer (*batafa*, COR). Also, the seer is not marked by *ga*. In (c), prefix agreement is indeterminate

between the seer and the thing seen (the apparent PAT), but the seer (lalaafa, the apparent COR) is marked by *ga* in direct contradiction to the pattern in (a). Likewise the thing seen (makomako, PAT) in (a) is marked by *ga*, while the thing seen (the apparent PAT) in (c) is not.

These three sentences involve an apparent conflict with regard to case marking which can be summarised as follows:

(a)	<u>COR</u>	<u>V</u>	<u>ga</u>	PAT
(b)		<u>V</u>	<u>ga</u>	PAT
(c')		<u>V</u>	<u>ga</u>	COR PAT
(c'')		<u>V</u>	<u>ga</u>	COR PAT

In this diagram the brackets indicate agreement between the verb prefix and a nominal constituent. (c') and (c'') represent two alternatives for type (c) sentences where agreement in the available sample sentences is ambiguous. The correspondence between case relations and case markers can be summarised alternatively as:

TYPE	COR	PAT	
(a)	<i>px</i>	<i>ga</i>	(well attested; section 5.3.3)
(b)	none	<i>px/ga</i>	(well attested; section 5.3.2)
(c')	<i>px/ga</i>	∅	(apparent conflict)
(c'')	<i>ga</i>	<i>px</i>	(opposite of (a))

The distribution of case markers in (a) and (b) is well attested in a large number of sentences, and therefore will be accepted as a standard point of reference.

The distribution in (c'') involves a complete reversal of the association between case markers and case relations of (a), and therefore can be ruled out as very unlikely.

In (c'), the association between the Correspondent and prefix agreement is not problematic since Correspondents in the well attested pattern (a) agree with verb prefixes. The apparent conflict arises in (c') from the assumption that the actant marked by the verb prefix agreement and *ga* is the Correspondent, and that the sentence is transitive. This assumption is suggested by two things: (1) the fact that the sentence contains two nominal constituents, and (2) the fact that the English translation is transitive.

If one is able to abandon his English speaker's intuition, thereby freeing himself to pay closer attention to patterning of syntactic markers, it becomes clear that the syntactic marking of the supposed Correspondent in type (c) sentences is indistinguishable from the marking of the Patient in intransitive sentences like the well attested type (b). Thus the apparent conflict observed in (c) can be avoided by accepting the alternative, and syntactically well justified, hypothesis that type (c) sentences are intransitive, and that the *ga* marked actant is the Patient.

One difficulty remains. If the *ga* marked actant in (c), *lalaafa*, is the Patient, what is the case relation of the other nominal constituent, *batafa rekona* in this type of intransitive sentence? It is not uncommon in Oceanic

languages to have syntactically intransitive verbs which occur with noun phrases which appear to be objects. Hiroshi Sugita (1973) cites numerous examples of such sentences in an analysis entitled "Semitransitive verbs and object incorporation in Micronesian languages".

That analysis relies heavily on subtle differences in meaning between syntactically transitive verbs and syntactically intransitive verbs which take noun phrases which appear to be objects. Such semantic detail is not available for these Mono-Alu sentences, but the patterning of case markers suggests that these type (c) sentences may correspond closely to the 'semitransitive' sentences discussed by Sugita.

This contrast between transitive and semitransitive constructions is also found with other Mono-Alu verb bases such as *golu eat (non-vegetable food)* and *lapu kill, strike, catch*. Both of these verbs are Type II transitives (that is, they do not carry transitive suffixes):

## (a) TRANSITIVE

6464	fanua	iri-golu-Ø-Ø	ga	Koriomu	
66ff	<i>people</i>	3p:nfut-eat-tr-3s	abs	<i>Koriomu</i>	
	AGT			PAT	
	<i>the people ate Koriomu</i>				
698	mafa	fai-lapu-lapu-Ø-ri	ita	ga	episa
7c	ls	ls:nfut-kill-kill-tr-3p	?	abs	<i>three</i>
	AGT				PAT
	<i>I have killed three</i>				

## (c) SEMITRANSITIVE

988	i-golu	pipilua	ga	mamaifa
8m	3s:nfut-eat	<i>human:bodies</i>	abs	<i>chiefly:woman</i>
		REF		PAT
	<i>the chief's woman ate the human bodies</i>			
571	i-lapu	ga	tiong	iana
6a	3s:nfut-kill	abs	<i>man</i>	<i>fish</i>
			PAT	REF
	<i>the man caught a fish</i>			

Sugita suggests, in agreement with Goodenough, that in constructions such as these the focus of the sentence is on the activity expressed by the verb rather than the effect of the verbal activity on an object (Sugita 1973:405). From this point of view type (c) sentence 571 might be more accurately interpreted as meaning *the man engaged in the activity of catching, with reference to fish*, that is, *the man went fishing*. Similarly 988 could be interpreted to mean *the mamaifa engaged in the act of eating with reference to human bodies*, that is, *the mamaifa ate (some) bodies, or the mamaifa ate of the bodies*.

These interpretations emphasise the activity expressed by the verb and the actor's relationship to the activity. In contrast to this, the transitive type (a) constructions can be interpreted as bringing into sharper focus the relationship between the verbal activity and the entity affected by the verbal activity.

Sugita (ibid.) suggests that the non-Patient nominal constituent in intransitive type (c) sentences might be assigned a case category distinct from the Patient actant in transitive sentences, but that so far an appropriated case category has not been available. With its definition as

identifying 'the target or evaluative reference point of the action or state as a whole' (Starosta 1977:23), the Reference case relation meets this need adequately.

For the purposes of this analysis, the non-Patient nominal in intransitive sentences such as (c) will be assigned the Reference case relation. Intransitive verbs thus can occur with an optional actant in the Reference case relation.

#### 5.4 Verbal derivation

In section 5.3 it was noted that transitive verbs can be derived from intransitive ones by adding the suffixes *i* or *ng*. In addition to these suffixes there are several other verbal derivational affixes in Mono-Alu. This section will briefly describe the use of these affixes.

##### 5.4.1 The transitive suffix *i*

Transitive verbs can be derived from certain intransitive verbs by suffixing *i*. This derivational process is exemplified by the following sentence pairs: (a) intransitive, (b) transitive.

*anee climb, anee-i climb something*

(a)

5449	<i>iri-anee</i>	<i>ga</i>	<i>fanua</i>	<i>ea</i>	<i>lima</i>
54f	3p:nfut- <i>climb</i>	abs	<i>men</i>	det	<i>five</i>
	<i>five men went up</i>				

(b)

2912	<i>i-ane-i-∅</i>	<i>ga</i>	<i>natu</i>
24a	3s:nfut- <i>climb-tr-3s</i>	abs	<i>tree</i>
	<i>he climbed up a natu tree</i>		

*lufu dive, lufu-i dive for something*

(a)

5660	<i>i-lufu</i>	<i>ga</i>	<i>Borua</i>
58a	3s:nfut- <i>dive</i>	abs	<i>Borua</i>
	<i>Borua dived</i>		

(b)

4643	<i>fana-lufu-i-∅</i>
47b	1s:fut- <i>dive-tr-3s</i>
	<i>I will dive for it</i>

*bilu go, get away, bilu-i leave something behind*

(a)

2718	<i>i-bilu</i>	<i>ga</i>	<i>fama</i>	<i>sa-na</i>
22a	3s:nfut- <i>go/get:away</i>	abs	<i>elder</i>	<i>thing-3s:pssv</i>
	<i>that belonging to the elder brother won (got away)</i>			

(b)

2095	<i>iri-bilu-i-∅</i>	<i>ga</i>	<i>elea</i>	<i>famata</i>
16p	3p:nfut- <i>get:away-tr-3s</i>	abs	det	<i>village</i>
	<i>they left a village behind them</i>			



mole *do wrong*, mole-i *do wrong to something*

(a)

1837	i-mole-mole	ga	toloo
15f	3s:nfut- <i>do:wrong-do:wrong</i>	abs	<i>eel</i>
	<i>the eel has done wrong</i>		

(b)

1836	i-mole-i-∅	ga	kai-gu
15f	3s:nfut- <i>do:wrong-tr-3s</i>	abs	<i>brother-1s:pssv</i>
	<i>it has done a wrong to my brother</i>		

Notice that in these pairs of sentences the nominative Patient of the intransitive sentences corresponds to the nominative Agent of the transitive sentences, and a new Patient is introduced into the case frame. For example, with *anee*, the climber is the nominative Patient. With *anee-i*, the climber is still nominative, but is now the Agent. This appears to be the same pattern recognised by Pawley for transitives derived from active intransitives by suffixing \*i. He expresses this notion by saying that the transitive derivation does not change the subject choice of the verb (Pawley 1978:4.14).

#### 5.4.2 The transitive suffix ng

Like the suffix *i*, *ng* derives transitives from intransitives. There appears, however, to be a difference in the relationship between the Agent and the Patient with verbs of the two types. This contrast, though not well represented in the texts, is suggested most strongly by the verb *galo* *carry* which occurs only transitively, but in two different transitive forms:

(1) V-∅-sfx, and (2) V-ng-sfx.

(1) *carry something*

2704	fai-galo-∅-ri	ma	ga	aanana
21q	1s:nfut- <i>carry-tr-3p</i>	dir	abs	<i>children</i>
	<i>I have brought back those children</i>			

(2) *carry to someone*

6645	i-galo-ng-∅	ga	fafine-na
67p	3s:nfut- <i>carry-tr-3s</i>	abs	<i>brother-3s:pssv</i>
	<i>she brought it to her brother</i>		

In (1), the Patient is the thing carried or brought, while in (2) it appears that the Patient is the person to whom something is carried. Unfortunately this contrast cannot be more fully investigated since 6645 is the only occurrence of *galo* in this form in the texts.

The Patient in *ng* transitive sentences appears to stand in an indirect object relationship to the verb. This is also suggested by other forms.

(a)

2535	iri-ela-male
21d	3p:nfut- <i>sing-again</i>
	<i>they sang again</i>

(b)

5084	emia-ela-ng-∅	Matairua
50h	2p:fut- <i>sing-tr-3s</i>	<i>Matairua</i>
	<i>(you) sing to Matairua</i>	

- (a)
- |      |                            |     |              |
|------|----------------------------|-----|--------------|
| 3546 | i-kafuru                   | ga  | lalaafa      |
| 35g  | 3s:nfut- <i>get:angry</i>  | abs | <i>chief</i> |
|      | <i>the chief got angry</i> |     |              |
- (b)
- |      |  |     |                            |
|------|--|-----|----------------------------|
| 3533 | i-kafuru-n-ri                          | ga  | la-iloa-na                 |
| 35f  | 3s:nfut- <i>get:angry-tr-3p</i>        | abs | pl- <i>co-wife-3s:pssv</i> |
|      | <i>she got wrath with fellow wives</i> |     |                            |

#### 5.4.3 The causative prefix fa

This prefix functions much like the prefix \*paka reconstructed by Pawley for POC. One difference, however, is that in Mono-Alu, transitives can be derived from both stative and active intransitives by prefixing fa. Pawley says that \*paka only transitivised statives (Pawley 1978:6.1).

- (a)
- |     |                            |     |             |
|-----|----------------------------|-----|-------------|
| 131 | i-mako                     | ga  | rarami      |
| lm  | 3s:nfut- <i>cook</i>       | abs | <i>food</i> |
|     | <i>the food was cooked</i> |     |             |
- (b)
- |      |                        |             |                          |
|------|------------------------|-------------|--------------------------|
| 3388 | maang                  | rarami      | emia-fa-mako             |
| 34c  | 2p                     | <i>food</i> | 2p:fut-caus- <i>cook</i> |
|      | <i>do ye cook food</i> |             |                          |
- (a)
- |      |                                    |     |            |
|------|------------------------------------|-----|------------|
| 6611 | i-popoa                            | ga  | abu        |
| 671  | 3s:nfut- <i>sound</i>              | abs | <i>sky</i> |
|      | <i>the sky sounded (thundered)</i> |     |            |
- (b)
- |      |                            |     |             |
|------|----------------------------|-----|-------------|
| 1199 | re-fa-popoa                | ga  | oko         |
| 9m   | 3p:nfut-caus- <i>sound</i> | abs | <i>drum</i> |
|      | <i>they beat the drum</i>  |     |             |
- (a)
- |     |                                  |  |  |
|-----|----------------------------------|--|--|
| 406 | iri-tulu                         |  |  |
| 4b  | 3p:nfut- <i>land</i>             |  |  |
|     | <i>they landed (went ashore)</i> |  |  |
- (b)
- |      |                                    |                           |              |
|------|------------------------------------|---------------------------|--------------|
| 6138 | Soi                                | iri-fa-tulu               | baoi         |
| 65t  | <i>Soi</i>                         | 3p:nfut-caus- <i>land</i> | <i>shark</i> |
|      | <i>the sharks set Soi on shore</i> |                           |              |

In contrast with i transitives, notice that the Patient in the intransitive sentences corresponds to the Patient in the fa transitive constructions. That is, with popoa, the Patient is the entity which sounds. Likewise with fa-popoa, the Patient is still the entity which sounds, though it is caused to do so by an external Agent.

The contrast in meaning between fa and i transitives is best illustrated by anee *climb, go up*, and reko *good* which occur in both forms.

fa-anee-i *take something up, anee-i climb something*

4373 i-fa-ane-i-∅ sa-na numa ang  
 44b 3s:nfut-caus-go:up-tr-3s thing-3s:pssv house loc  
*he carried him up into his house*

2912 i-ane-i-∅ ga natu  
 24a 3s:nfut-climb-tr-3s abs tree  
*he climbed up a natu tree*

fa-reko *fix, make good, reko-i do right to, treat well, reko be good*

178 lau iri-fa-reko borotoko ga fanua  
 2c then 3p:nfut-caus-good fence abs men  
*then the men mended the fence*

3112 fai-reko-i-∅  
 29d 1s:nfut-good-tr-3s  
*I have done right to him*

2148 i-reko ga nife  
 16t 3s:nfut-good abs snake  
*it is all right about the snake now*

#### 5.4.4 The stative prefix ta

Bases can be made stative by prefixing ta. This form occurs only with the verb *posa break* in Wheeler's texts.

891 i-posa-i-∅ ga niunu  
 8e 3s:nfut-break-tr-3s abs coconut  
*she broke coconuts*

1325 fana-posa-i-∅  
 10b 1p:fut-break-tr-3s  
*I will break it*

1303 abu i-ta-posa  
 10a neg 3s:nfut-stat-break  
*it was not broken*

#### 5.4.5 The reciprocal prefix fang

The prefix fang adds a reciprocal meaning to the action indicated by the verb. In Wheeler's texts, this prefix occurs only with the verb *lapu hit, kill*.

6310 iri-fan-lapu-lapu ena kaiela  
 66n 3p:nfut- recip-kill-kill with staff  
*they fought (hit one another) with their staves*

695 i-lapu-lapu-∅-ri ga episa  
 7c 3s:nfut-kill-kill-tr-3p abs three  
*he killed three*

## 5.4.6 The prefix fero

The prefix fero added to a verb indicates that the action or event described by the verb takes place or is directed toward a location other than the current context of the utterance. The form can generally be glossed *elsewhere*, *somewhere else*.

1963	maang	ate	emia-fero-gagana		
16f	2p	neg	2p:fut-elsewhere-go		
			<i>do not go away</i>		
3676	i-gagana	ga	karo		
36e	3s:nfut-go	abs	parrot		
			<i>the parrot went</i>		
4779	pipilua		ona-fero-selo		
48g	human:bodies	2s:fut-elsewhere-boil			
			<i>cook human bodies in another (pot)</i>		
			<i>(cook human bodies somewhere else)</i>		
6246	i-selo	ga	pausape		
66g	3s:nfut-boil	abs	stone		
			<i>he boiled stones</i>		
6619	ona fero-soku		uta		
67m	2s:fut-elsewhere-arrive		?		
			<i>you will go away to another place</i>		
888	i-soku	ga	magota		
8e	3s:nfut-arrive	abs	old:woman		
			<i>the old woman came back</i>		

## 5.4.7 The repetitive suffix male

The suffix male indicates that the action described by the verb is repeated. Wheeler usually represents this form as a word separate from the verb. However, its distribution with respect to other verb suffixes suggests that it is in fact a suffix.

6298	i-fauka-i-male-ri	ga	aanana	aabau	Roai
66m	3s:nfut-meet-tr-again-3p	abs	children	some	Roai
			<i>he met some more children at Roai</i>		
6292	i-fauka-i-ri	ga	aanana	Kureke	
66l	3s:nfut-meet-tr-3p	abs	children	Kureke	
			<i>he met some children at Kureke</i>		
1884	re-gagana-male	saiga	ang		
16a	3p:nfut-go-again	garden	loc		
			<i>they went again to the garden</i>		





mafa '1s'	maito '2s'	maita '1pI'	mani '1pE'	maang '2p'
$\begin{pmatrix} -\text{plur} \\ +\text{spkr} \end{pmatrix}$	$\begin{pmatrix} -\text{plur} \\ -\text{spkr} \\ +\text{addr} \end{pmatrix}$	$\begin{pmatrix} +\text{plur} \\ +\text{spkr} \\ +\text{addr} \end{pmatrix}$	$\begin{pmatrix} +\text{plur} \\ +\text{spkr} \\ -\text{addr} \end{pmatrix}$	$\begin{pmatrix} +\text{plur} \\ -\text{spkr} \\ +\text{addr} \end{pmatrix}$

The combinations of features defined by SR-4 through RR-3 are given in Figure 10 together with their corresponding lexical items and glosses.

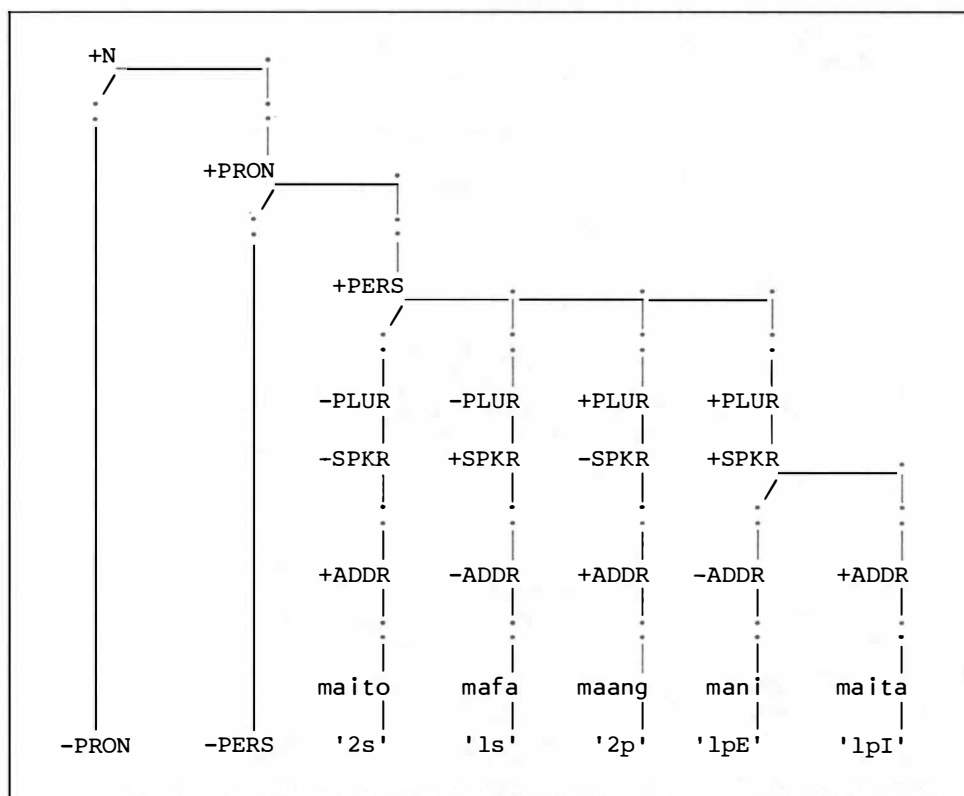

Figure 10: Feature combinations of personal pronouns defined by rules SR-4 through RR-3

SR-8	$[-\text{pers}]$	$\rightarrow$	$[\pm\text{dem}]$
RR-7	$[-\text{dem}]$	$\rightarrow$	$[\text{+intr}]$
RR-8	$[-\text{pers}]$	$\rightarrow$	$\begin{pmatrix} -\text{spkr} \\ -\text{addr} \end{pmatrix}$

Non-personal pronouns are either demonstrative pronouns or not (SR-8). Non-demonstratives are interrogative (RR-7). All non-personal pronouns are third person (RR-8).

SR-9	$[-\text{dem}]$	$\rightarrow$	$[\pm\text{LOC}]$
------	-----------------	---------------	-------------------

Non-demonstratives (interrogatives) either indicate a location or not.

RR-9	$[\pm\text{dem}]$	$\rightarrow$	$[-\text{pers}]$
------	-------------------	---------------	------------------

RR-9 together with RR-5 and RR-6 specify certain redundancies which make it possible to reduce the lexical specifications of non-personal pronouns to the following features.

ea		
enaa		
oa (etc.)	ale <i>who</i>	fina <i>where</i>
[+dem]	$\begin{pmatrix} -\text{dem} \\ -\text{LOC} \end{pmatrix}$	$\begin{pmatrix} -\text{dem} \\ +\text{LOC} \end{pmatrix}$

The combinations of features defined by rules SR-8 through SR-9 are given in Figure 11, together with sample lexical items.

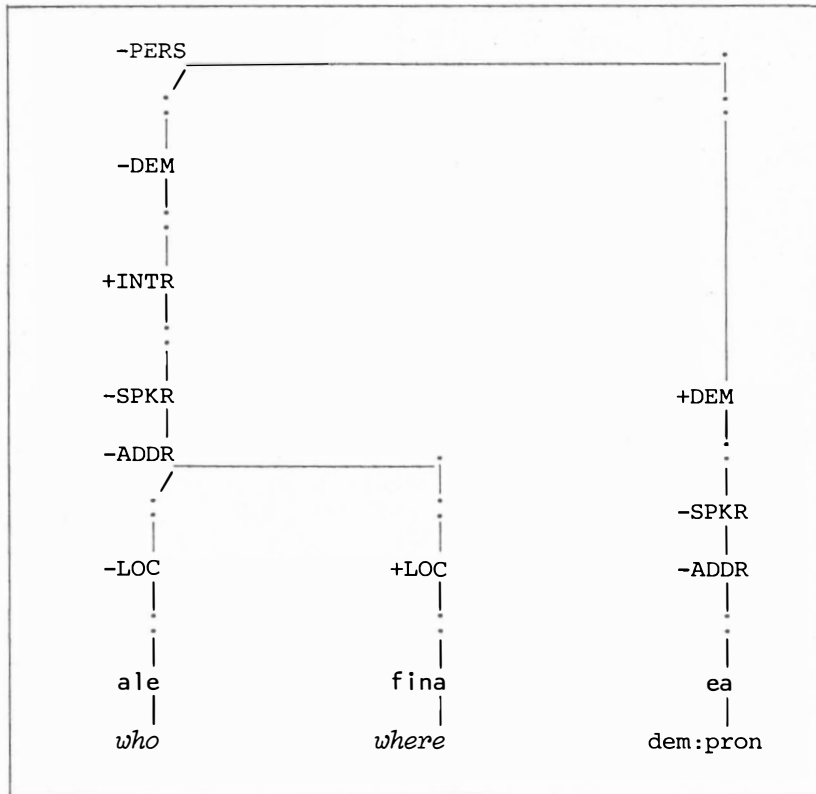

Figure 11: Feature combinations of demonstrative and interrogative pronouns as defined by SR-8 through SR-9

RR-10 [-pron] →  $\begin{pmatrix} -\text{spkr} \\ -\text{addr} \\ + \_ ([+PAT]) \\ +([+det]) \\ + \_ ([+S]) \end{pmatrix}$  (a)  
 (b)  
 (c)  
 (d)  
 (e)

This rule states that all non-pronouns are third person (a-b). Further, non-pronouns can be followed optionally by a nominal attribute in the Patient case relation (c), be preceded optionally by a determiner (d), or have an optional sentential attribute (e).



Part (c) provides for the nominal attributes discussed in section 3.2, the appositive modifiers of section 3.3, and the Patient attributes discussed in section 2.2.2.3. Part (e) provides for relative clauses as discussed in section 3.4.

With regard to inflection for plurality, there are several types of nouns in Mono-Alu. A few nouns are inherently singular such as *tiong man*, and *batafa woman*. These correspond to a set which are inherently plural, *fanua men*, *talaiva women*. Such nouns must be lexically marked for singularity [-plur] or plurality [+plur]. Disregarding nouns such as those, three classes of Mono-Alu nouns must be recognised on the basis of how they are pluralised. A small set of nouns are pluralised by adding the prefix *la*. Many of these forms are kin terms such as *kai brother*, and *tua grandfather*. Boch (n.d.:2) suggests, however, that this method of pluralisation may not be restricted to kin terms. Since nouns which pluralise in this way cannot be identified by any other formal syntactic features, these nouns are lexically marked with the feature [+lapl].

Another set of nouns pluralise by reduplication of their initial syllables: *kanega husband*, *kakanega husbands*, and *abaisa girl*, *aabaisa girls*. Nouns which pluralise in this way carry the lexical feature [+rdpl].

For most nouns it appears that plurality is not morphologically marked. That such nouns can be inflected for plurality is indicated indirectly by the form of verb agreement affixes. This is demonstrated by *sana auau his dogs* in sentence 3358, where the verb suffix indicates a plural Patient.

3358	i-tele-ri	leako ga	sa-na	auau
34b	3s:nfut-give-3p	magic	abs	thing-3s:pssv
	<i>he gave his dogs a magic</i>			

Subcategorisation rules 10 and 11 formally define these three classes of nouns.

SR-10	[-pron]	→	[±lapl]
SR-11	[-lapl]	→	[±rdpl]

Redundancy rules 11 and 12 simplify the lexical representation of all common nouns.

RR-11	[±rdpl]	→	[-lapl]
RR-12	[±lapl]	→	[-pron]

Inflection for plurality and possession is specified by subcategorisation rule SR-12.

SR-12	[-pron]	→	$\begin{pmatrix} \pm\text{plur} \\ \pm\text{pssd} \end{pmatrix}$
-------	---------	---	--

Combinations of features defined by RR-10 and SR-10 through SR-12 are illustrated in Figure 12.

Presence of the feature [+lapl] in combination with the inflectional feature [+plur] conditions the application of the morphophonemic inflectional redundancy rule IRR-1 which prefixes *la* to the form.

IRR-1	[	→	[la	/	$\begin{pmatrix} \pm\text{lapl} \\ \pm\text{plur} \end{pmatrix}$
-------	---	---	-----	---	--

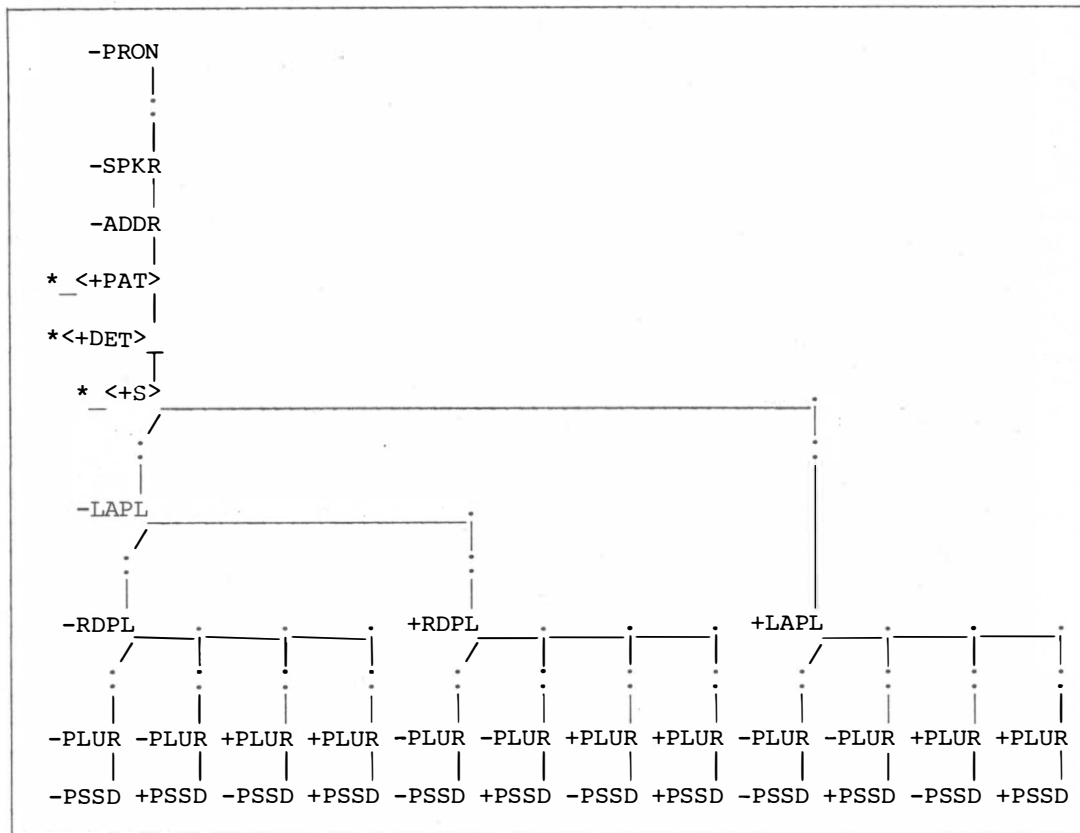

Figure 12: Feature combinations of common nouns defined by RR-10 through SR-12<sup>8</sup>

Similarly a noun carrying the feature [+rdpl] which is inflected for plurality will have its initial syllable reduplicated, as specified by IRR-2.<sup>9</sup>

$$\text{IRR-2} \quad [(C^1)V^1] \quad \rightarrow \quad [C^1V^1C^1V^1 / \left( \begin{array}{l} +rdpl \\ +plur \end{array} \right)]$$

As explained in chapter 2, suffix-possessed nouns [pssd] occur with an optional attribute in the Correspondent case relation. This nominal attribute is the possessor of the suffix-possessed noun. The suffix of the possessed noun must agree in person and number with this nominal possessor.

The following inflectional subcategorisation rules provide for an optional Correspondent attribute and specify agreement by assigning contextual features to [+pssd] nouns.

$$\text{SR-13} \quad [+pssd] \quad \rightarrow \quad \left( \begin{array}{l} +([+COR]) \\ - \left( \begin{array}{l} +COR \\ \pm plur \end{array} \right) \\ - \left( \begin{array}{l} +COR \\ \pm spkr \end{array} \right) \end{array} \right)$$

SR-14	$\left( \begin{array}{c} - \left( \begin{array}{c} +\text{COR} \\ +\text{spkr} \end{array} \right) \\ - \left( \begin{array}{c} +\text{COR} \\ -\text{plur} \end{array} \right) \\ - \left( \begin{array}{c} +\text{COR} \\ -\text{spkr} \end{array} \right) \end{array} \right)$	→	$\left( \begin{array}{c} - \left( \begin{array}{c} +\text{COR} \\ \pm\text{addr} \end{array} \right) \end{array} \right)$
IRR-1	$\left( \begin{array}{c} - \left( \begin{array}{c} +\text{COR} \\ +\text{plur} \end{array} \right) \\ - \left( \begin{array}{c} +\text{COR} \\ -\text{spkr} \end{array} \right) \end{array} \right)$	→	$\left( \begin{array}{c} - \left( \begin{array}{c} +\text{COR} \\ +\text{addr} \end{array} \right) \end{array} \right)$
IRR-2	$\left( \begin{array}{c} - \left( \begin{array}{c} +\text{COR} \\ \pm\text{plur} \end{array} \right) \end{array} \right)$	→	[+pssd]
IRR-3	$\left( \begin{array}{c} - \left( \begin{array}{c} +\text{COR} \\ +\text{plur} \end{array} \right) \\ - \left( \begin{array}{c} +\text{COR} \\ -\text{addr} \end{array} \right) \end{array} \right)$	→	$\left( \begin{array}{c} - \left( \begin{array}{c} +\text{COR} \\ +\text{spkr} \end{array} \right) \end{array} \right)$

In addition to specifying agreement between the nominal possessor and suffix-possessed noun, these contextual features also condition the application of morphophonemic rules which attach possessive suffixes to possessed nouns. Inflectional redundancy rules IRR-4 through IRR-10 define the correspondence between inflectional features and possessive suffixes.

IRR-4	]	→	ra] lpI:pssv	/	$\left( \begin{array}{c} - \left( \begin{array}{c} +\text{COR} \\ -\text{plur} \end{array} \right) \\ - \left( \begin{array}{c} +\text{COR} \\ -\text{spkr} \end{array} \right) \\ - \left( \begin{array}{c} +\text{COR} \\ -\text{addr} \end{array} \right) \end{array} \right)$
IRR-5	]	→	mang] lpE:pssv	/	$\left( \begin{array}{c} - \left( \begin{array}{c} +\text{COR} \\ -\text{plur} \end{array} \right) \\ - \left( \begin{array}{c} +\text{COR} \\ -\text{spkr} \end{array} \right) \\ - \left( \begin{array}{c} +\text{COR} \\ +\text{addr} \end{array} \right) \end{array} \right)$
IRR-6	]	→	mia] 2p:pssv	/	$\left( \begin{array}{c} - \left( \begin{array}{c} +\text{COR} \\ -\text{plur} \end{array} \right) \\ - \left( \begin{array}{c} +\text{COR} \\ +\text{spkr} \end{array} \right) \\ - \left( \begin{array}{c} +\text{COR} \\ -\text{addr} \end{array} \right) \end{array} \right)$
IRR-7	]	→	ria] 3p:pssv	/	$\left( \begin{array}{c} - \left( \begin{array}{c} +\text{COR} \\ -\text{plur} \end{array} \right) \\ - \left( \begin{array}{c} +\text{COR} \\ +\text{spkr} \end{array} \right) \\ - \left( \begin{array}{c} +\text{COR} \\ +\text{addr} \end{array} \right) \end{array} \right)$

IRR-8	]	→	gu] 1s:pssv	/	$\begin{pmatrix} -(+COR) \\ (+plur) \\ -(+COR) \\ (-spkr) \end{pmatrix}$
IRR-9	]	→	ng] 2s:pssv	/	$\begin{pmatrix} -(+COR) \\ (+plur) \\ -(+COR) \\ (-addr) \end{pmatrix}$
IRR-10	]	→	na] 3s:pssv	/	$\begin{pmatrix} -(+COR) \\ (+plur) \\ -(+COR) \\ (+spkr) \\ -(+COR) \\ (+addr) \end{pmatrix}$

Rules SR-13 through IRR-1 define the inflectional feature combinations illustrated in Figure 13. The suffixes below each terminal node are the ones assigned to each combination of features by IRR-4 through IRR-10.

A lexicase grammar requires that all nouns carry a case relation feature and a case form feature. These features are assigned by inflectional subcategorisation and redundancy rules which also formally specify the relationship between case relations and case forms.

SR-15	[+N]	→	[±NM]
SR-16	[+NM]	→	[±PAT]
SR-17	[-PAT]	→	[±AGT]
IRR-11	[-AGT]	→	[+COR]
SR-18	[-NM]	→	[±AC]
IRR-12	[+AC]	→	[+PAT]
SR-19	[-AC]	→	[±LOC]
SR-20	[-LOC]	→	[±PLC]
SR-21	[-PLC]	→	[±INS]
SR-22	[-INS]	→	[±CON]
IRR-13	[-CON]	→	[+REF]

The feature combinations defined by these rules are illustrated in Figure 14. From that diagram it can be seen that Correspondents and Agents are always nominative [+NM], that Patients are either nominative or accusative [+AC], and that all other case relations are non-accusative [-AC]. A case relation can be realised by a case form other than those defined by these rules only by occurring in a prepositional or postpositional phrase.

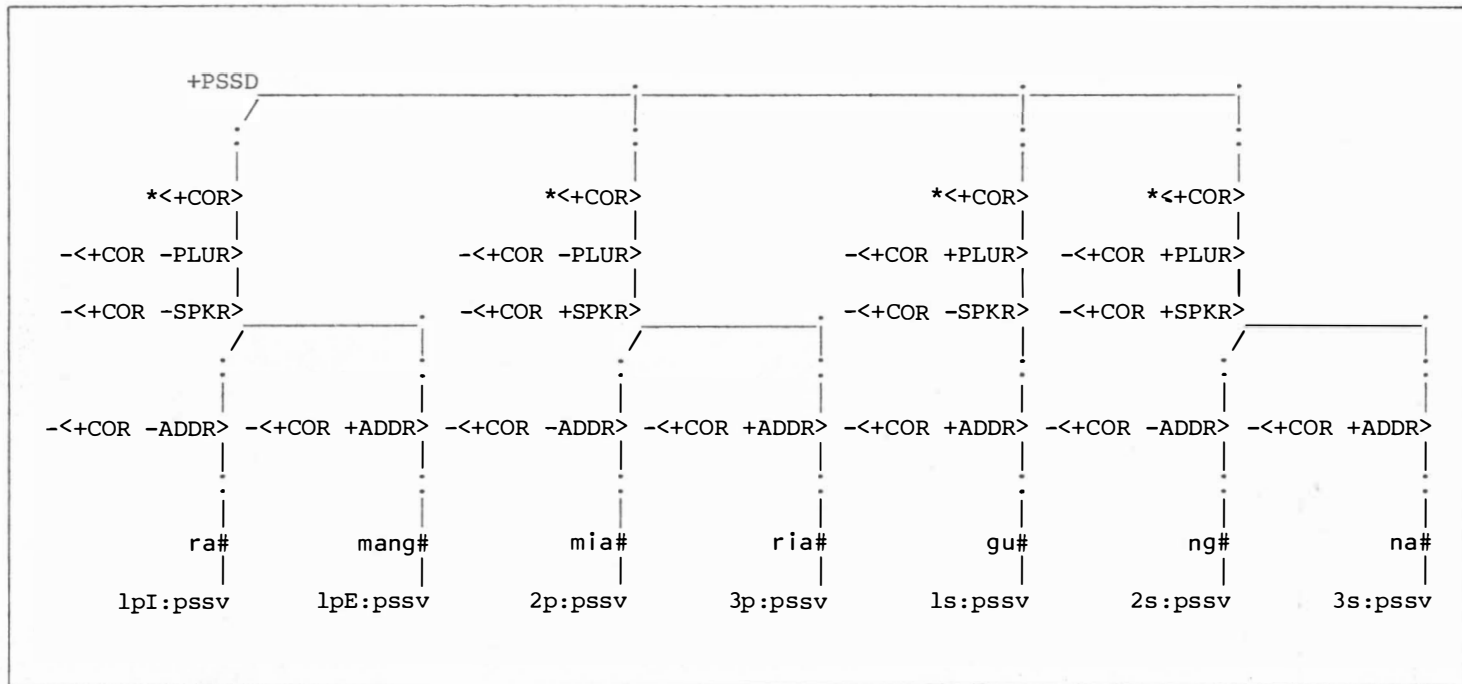

Figure 13: Inflectional features of suffix-possessed nouns as defined by rules SR-13 through IRR-1. Possessive suffixes assigned by rules IRR-4 through IRR-10.



Figure 14: Combinations of case relation and case form features defined by rules SR-15 through IRR-12

## 6.2 Verb subcategorisation and redundancy rules

In a lexibase grammar, the form of a verbal construction is defined in terms of the case relations each verb allows or requires its nominal constituents to be in, and with regard to the case forms which realise those case relations. The next five subcategorisation rules define the ten syntactic categories of verbs hypothesised for Mono-Alu.

SR-23	[+V]	→	[±[+PAT]]
SR-24	[+[+PAT]]	→	$\left( \begin{array}{l} \pm[+AGT] \\ \pm([+LOC]) \end{array} \right)$
SR-25	[+[+AGT]]	→	[±([+INS])]
SR-26	$\left( \begin{array}{l} -[+LOC] \\ +[+INS] \end{array} \right)$	→	$\left( \begin{array}{l} \pm[+INS] \\ +I \end{array} \right)$
SR-27	[-[+AGT]]	→	[±[+COR]]

Before discussing these categories further, it is necessary to briefly consider the form of two of these rules, SR-24 and SR-25. Rule SR-25, for example, defines the feature specifications:

$$\left( \begin{array}{l} +[+AGT] \\ +([+INS]) \end{array} \right), \text{ and } \left( \begin{array}{l} +[+AGT] \\ -([+INS]) \end{array} \right)$$

The first of these is the desired combination of features, but the second is at best inaccurate if not meaningless. What would it mean to optionally disallow the presence of a case relation?

The intent of this rule is to define two classes of agentive verbs; one which allows but does not require an Instrument  $[+([+INS])]$ , and one which disallows an Instrument  $-([+INS])$ . The nature of subcategorisation rules, however, makes it impossible to make such a statement. The closest approximation is a rule like SR-24 or SR-25.

The only way to avoid a rule of this form would be to refrain from formally defining the categories at all, and thus be forced to specify the features lexically for every verb belonging to those categories. This approach, however, fails to formally recognise two syntactic classes of verbs and thus fails to state a significant generalisation about the structure of the language. In order to avoid losing this general statement, it will be assumed that a feature of the form  $-([+F])$  is equivalent to  $-[+F]$ .

According to SR-23, verbs either allow a Patient actant or not. Those that do not are meteorological verbs such as *lale become day*.

Verbs which allow Patients can be further subcategorised according to whether or not they allow Agent and Locus actants. Agentive verbs are further divided into those which disallow or optionally allow actants in the Instrument case relation. The agentive verb *lapu hit, kill* for example allows both a Locus and an Instrument, while *nkoti grasp* allows only a Locus in addition to the Agent and Patient.

Agentive verbs which allow an Agent and Instrument, but not a Locus, are further divided into those whose Instrument must be realised by the instrumental case form  $[+I]$  and those which allow an Instrument, but not realised by the  $[+I]$  case form. *lafa hit*, for example, allows a  $[+I]$  Instrument. Only *tele give* requires a non-instrumental Instrument. *tele's* lexical representation further specifies that its Instrument actant must be realised by the  $[-AC]$  case form.

The last class of agentive verbs contains verbs which allow neither a Locus nor an Instrument; *seguli step on* is an example.

The agentive verb classes defined by these rules are illustrated in Figure 15. Sample sentences appear in Figure 16.

Subcategorisation with regard to Locus and Instrument actants must be regarded only as a tentative hypothesis about the case frames of these verbs. Where there is definite evidence provided by the texts that a Locus or Instrument actant can occur with a particular verb, that verb has been categorised as  $[+ [+LOC]]$  and/or  $[+ [+INS]]$ . Verbs which do not occur in these texts with actants in these case relations have been categorised as  $[- [+LOC]]$  and/or  $[- [+INS]]$ , even though it might be found upon testing that some of these verbs do allow actants in one or both of these case relations. This, however, is a matter for investigation with a native speaker.

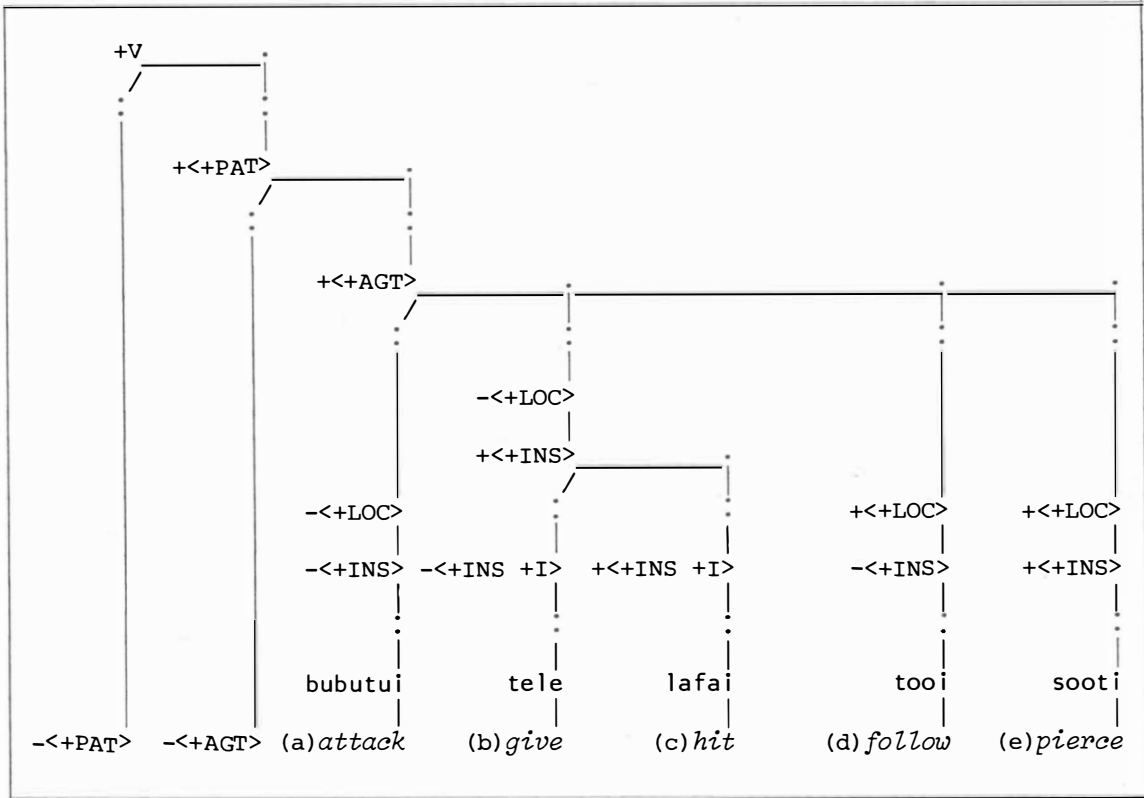

Figure 15: Agentic verb classes  
 Letters in brackets refer to sample sentences in Figure 16

(a)					
1455	iri-bubutu-i	ga	boo	auau	
12b	3p:nfut-attack-tr	abs	pig	dog	
		[+AB]	[+PAT]	[+AGT]	
	<i>the dogs attacked the pig</i>				
5727	i-koro-i	ga	tia-na		
60c	3s:nfut-peck-tr	abs	belly-3s:pssv		
		[+AB]	[+PAT]		
	<i>it pecked at his belly</i>				
(b)					
3781	batafa i-tele	ga	nife	tapoina	rarami
37d	woman 3s:nfut-give	abs	snake	much	food
	[+AGT]	[+AB]	[+PAT]	(+INS) (-AC)	
	<i>the woman gave the snake plenty of food</i>				
	<i>(the woman presented the snake with plenty of food)</i>				

Figure 16 continued ...



continued ...

(b)					
252	mani	rarami	tiong	i-tele-ami	ibai
3c	1pE	food	man	3s:nfut-give-1pE	now
	[+PAT]	[+INS]	[+AGT]		
		[-AC]			
	<i>a man gave us food today</i>				
(c)					
5314	iri-lafa-i	ena	mua		
52m	3p:nfut-hit-tr	with	club		
		[+I]	[+INS]		
	<i>they beat him with clubs</i>				
5758	ena	too-mang		ami-bage	
60d	with	head-1pE:pssv		1pE:nfut-shuck	
	[+I]	[+INS]			
	<i>we took out the fish from the shell with our heads</i>				
(d)					
1386	i-nkot-i		tiga	atele	
11c	3s:nfut-grasp/take-tr		from	water	
			[+L]	[+LOC]	
	<i>he took it out of the water</i>				
1390	i-too-i	ga	kuau	atele	a
11c	3s:nfut-follow-tr	abs	frog	water	loc
		[+AB]	[+PAT]	[+LOC]	[+L]
	<i>he came upon the frog by the river</i>				
(e)					
1855	iri-soot-i	too-na		ang	
15f	3p:nfut-pierce-tr	head-3s:pssv		loc	
		[+LOC]		[+L]	
	<i>they pierced it in the head</i>				
1692	i-soot-i	ena	potulu		
14g	3s:nfut-pierce-tr	with	spear		
		[+I]	[+INS]		
	<i>he pierced him with a spear</i>				

Figure 16: Sentences with agentive [+AGT] verbs  
Letters in parentheses refer to verb classes illustrated in Figure 15

Rule SR-27 divides non-agentive verbs into two classes; one which allows an actant in the Correspondent case relation, and one which does not. Like [+AGT] verbs, [+COR] verbs are transitive. Intransitive verbs carry the features [-COR], [-AGT]. In addition to a Correspondent, *roroi see* also optionally allows a Locus which indicates the location of the Patient (the thing seen). Other [+COR] verbs such as *onogui recognise* and *paitei be angry at* do not allow a Locus.



continued ...

(g)						
2148	i-reko	ga	nife			
16t	3s:nfut-good	abs	snake			
		[+AB]	[+PAT]			
	<i>it is all right about the snake now</i>					
	<i>(the snake is all right now)</i>					
(h)						
239	iri-tolaf-i	ga	kokong			
3b	3p:nfut-taste-tr	abs	taro			
		[+AB]	[+PAT]			
	<i>they tasted the taro</i>					
241	iri-tolaf-i	ga	toitoi			
3b	3p:nfut-taste-tr	abs	banana			
		[+AB]	[+PAT]			
	<i>they tasted the bananas</i>					
(i)						
4788	fana-anee	numa	ang			
48h	1s:fut-go:up	house	loc			
		[+LOC]	[+L]			
	<i>I will go up to your house</i>					
1406	ea kuau	i-lufu-male	atele	a		
11d	det frog	3s:nfut-dive-again	water	loc		
	[+PAT]		[+LOC]	[+L]		
	<i>the frog dived again into the river</i>					
(j)						
6330	emia-roro-i	ga	rarami	tia-na	ang	aroaro
66r	2p:fut-see-tr	abs	food	belly-3s:pssv	loc	basket
		[+AB]	[+PAT]	[+LOC]	[+L]	
	<i>(you will) look at the food inside the baskets</i>					
1886	re-non-i	ga	auau	kufi	a	
16a	3p:nfut-hear-tr	abs	dog	cave	loc	
		[+AB]	[+PAT]	[+LOC]	[+L]	
	<i>they heard a dog in a cave</i>					
3116	natu-ria	i-non-i-ri	ma tiga	peta		
29e	child-3p:pssv	3s:nfut-hear-tr-3p	dir from	ground		
	[+COR]		[+L]	[+LOC]		
	olova-na	ang				
	inside-3s:pssv	loc				
	[+LOC]	[+L]				
	<i>their son heard them from below the ground</i>					

Figure 18: Sentences containing non-agentive [-[+PAT]] and [-[+AGT]] verbs  
Letters in parentheses refer to verb classes in Figure 17

Certain redundancies inherent in the verb subcategorisation scheme defined by rules SR-23 through SR-27 can be stated in the form of redundancy rules. These rules make it possible to significantly reduce the complexity of the lexical entries of verbs. From the non-redundant features of each lexical item in Figures 15 and 17, rules RR-13 through RR-19 can predict all other syntactic features.

RR-13	$\left( \begin{array}{c} \pm [+INS] \\ +I \end{array} \right)$	→	$[+([+INS])]$
RR-14	$[\pm [+AGT]]$	→	$[+[+AGT]]$
RR-15	$[\pm [+COR]]$	→	$[-[+AGT]]$
RR-16	$[\pm [+AGT]]$	→	$[+[+PAT]]$
RR-17	$[\pm [+PAT]]$	→	$[+V]$
RR-18	$[+[+PAT]]$	→	$\left( \begin{array}{l} - \left( \begin{array}{c} +PAT \\ +AB \end{array} \right) \text{---} \\ +([+REF]) \\ +([+PLC]) \\ +([+CON]) \\ - \left( \begin{array}{c} +LOC \\ \pm NM \end{array} \right) \\ - \left( \begin{array}{c} +PLC \\ \pm NM \end{array} \right) \\ - \left( \begin{array}{c} +CON \\ \pm NM \end{array} \right) \\ - \left( \begin{array}{c} +INS \\ \pm NM \end{array} \right) \\ +([+N]) \\ +([+P]) \end{array} \right)$
RR-19	$\left\{ \begin{array}{l} [+ [+AGT]] \\ [+ [+COR]] \end{array} \right\}$	→	$\left( \begin{array}{l} - \left( \begin{array}{c} +PAT \\ +NM \end{array} \right) \\ - \left( \begin{array}{c} +PAT \\ +AC \end{array} \right) \end{array} \right)$

Part (a) of RR-18 specifies that Patients realised by the absolutive case form [+AB] cannot precede the verb. This feature formally specifies that Patients cannot be marked by ga when preceding the verb, as explained above in sections 5.2 and 5.3.

Parts (b-d) state that all [+PAT] verbs can optionally co-occur with actants in one or more of the outer case relations, Reference [+REF], Place [+PLC], or Concomitant [+CON].

Parts (e-h) specify that actants in the Locus, Place, Concomitant, and Instrument case relations cannot be realised by the nominative [+NM], accusative [+AC], or non-accusative [-AC] case forms. These features, together with certain features of prepositions and postpositions, assure that actants in these case relations occur only within a pre- or postpositional phrase. Thus these case relations are realised only by the locative [+L], comitative [+CM], and instrumental [+I] case forms. Verbs which are exceptions to these, such as *tele give* are marked lexically.

Parts (i) and (j) are necessary only in order to assure that the 'omega rule' (Starosta 1978:4 and below, section 6.4) does not add features which state that nouns and prepositions cannot occur as sisters to verbs.

Part (k) of RR-19 states that transitive verbs cannot occur with nominative Patients. This rule assures, then, that transitive verbs will occur only with accusative [+AC] or absolutive [+AB] Patients, since those are the only other case forms that realise the Patient case relation.

Part (l) states that an accusative Patient cannot follow the verb. Together with part (a) of RR-18, this assures that only accusative Patients will precede transitive verbs and only absolutive Patients will follow transitive verbs.

$$\text{RR-20} \quad [-[+COR]] \quad \rightarrow \quad \left[ \begin{array}{l} - \left( \begin{array}{l} +PAT \\ +AC \end{array} \right) \quad (m) \\ - \quad \left( \begin{array}{l} +PAT \\ +NM \end{array} \right) \quad (n) \end{array} \right]$$

Part (m) of RR-20 states that intransitive verbs cannot co-occur with accusative Patients, thus assuring that intransitive verbs will have either nominative or absolutive Patients.

Part (n) states that a nominative Patient cannot follow an intransitive verb. In conjunction with part (a) of rule RR-18, this specifies that only nominative Patients precede intransitive verbs and only absolutive Patients follow intransitive verbs.

The features introduced by rules RR-18 (a), RR-19 (l), and RR-20 (n) account for the distribution of *ga* with respect to the verb, as explained in sections 5.2 and 5.3. That is, when a Patient follows the verb it must be marked by *ga*, but when it precedes the verb it cannot be marked by *ga*.

Consider, for example, the verb *gagana go*, with non-redundant features  $[-[+COR], +([+LOC])]$ . Rules RR-15, 16, 18, and 20 provide for the addition of several other features. Those relevant to the current discussion are shown in (1).

(1) *gagana go*

$$\left[ \begin{array}{l} +[+PAT] \\ - \left( \begin{array}{l} +PAT \\ +AB \end{array} \right) \quad (a) \\ - \quad \left( \begin{array}{l} +PAT \\ +NM \end{array} \right) \quad (b) \\ - \left( \begin{array}{l} +PAT \\ +AC \end{array} \right) \quad (c) \end{array} \right]$$

These features allow structures (T31) and (T32), but disallow structures (T33), (T34), (T35), and (T36).

(T31)

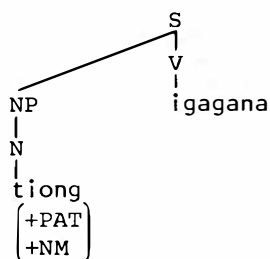

(T32)

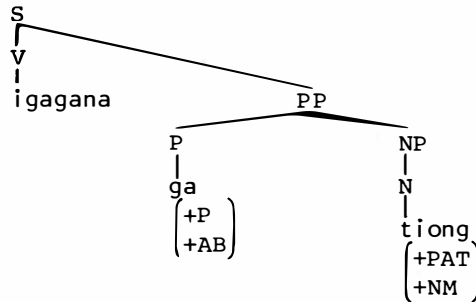

As specified by rules SR-16 and IRR-12, all Patients carry either the [+NM] or [+AC] case form feature. However, in structure (T32), tiong occurs in a prepositional phrase whose lexical head, ga, carries the case form feature [+AB]. Due to the hierarchical structure of the prepositional phrase, the Patient, tiong, is realised by the [+AB] case form since the case form of the lexical head of a construction takes precedence over the case form of a secondary head (see De Guzman 1976:73-74). Thus feature (b) of gagana is not violated by the [+NM] case form feature of tiong. The fact that the case form of a lexical head takes precedence over the case form of a secondary head will again become important in the discussion of specifying agreement between verb affixes and actants in the Patient case relation.

Feature (c) of gagana rules out both structures (T33) and (T34) by disallowing accusative [+AC] Patients anywhere in the environment of the verb.

(T33)

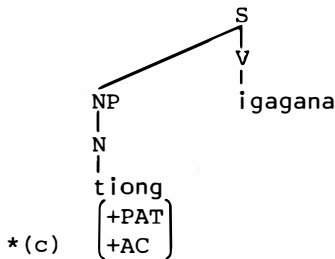

(T34)

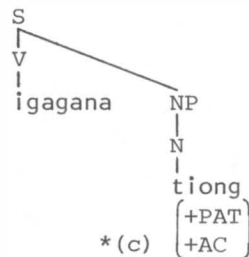

Feature (b) of gagana rules out structure (T35) by requiring that nominative actants not follow the verb.

(T35)

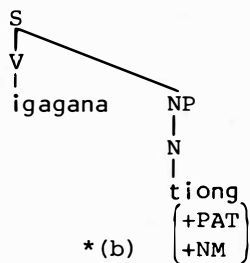

Structure (T36) violates feature (a) since *ga*, with its case form feature [+AB], precedes the verb.

(T36)

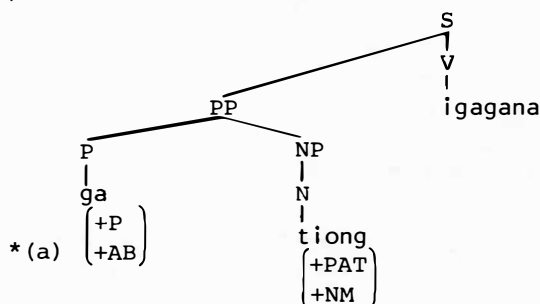

As discussed in chapter 5, Mono-Alu's marker of the nominative case form is verb prefix agreement. That is, the nominative actant (Patient, Correspondent, or Agent) and the verb prefix must agree in person and number. Verb affix agreement is specified in the same way as is possessive suffix agreement (see rules SR-13 through IRR-1). That is, contextual features are assigned to the construction head, in this case the verb, by inflectional subcategorisation and redundancy rules. These contextual features also condition the application of morphophonemic inflectional redundancy rules which attach agreement affixes to the verb stem.

$$\text{SR-28} \quad [-[+PAT]] \quad \rightarrow \quad \left[ \begin{array}{l} \pm\text{fut} \\ - \left( \begin{array}{l} +\text{NM} \\ +\text{plur} \end{array} \right) \\ - \left( \begin{array}{l} +\text{NM} \\ +\text{spkr} \end{array} \right) \\ - \left( \begin{array}{l} +\text{NM} \\ +\text{addr} \end{array} \right) \end{array} \right]$$

This rule states that all verbs that do not allow Patient actants (meteorological verbs) can have either future or non-future prefixes, but that the prefixes must always be third person singular. Examples are *i-boi it became night* and *ena-boi it will become night*.

$$\text{SR-29} \quad [+ [+PAT]] \quad \rightarrow \quad \left[ \begin{array}{l} \pm\text{fut} \\ - \left( \begin{array}{l} +\text{NM} \\ \pm\text{plur} \end{array} \right) \\ - \left( \begin{array}{l} +\text{NM} \\ \pm\text{spkr} \end{array} \right) \end{array} \right]$$

IRR-14	$\left( \begin{array}{c} - \left( \begin{array}{c} +NM \\ +plur \end{array} \right) \\ - \left( \begin{array}{c} +NM \\ -spkr \end{array} \right) \end{array} \right)$	→	$\left( \begin{array}{c} - \left( \begin{array}{c} +NM \\ +addr \end{array} \right) \end{array} \right)$
SR-30	$\left\{ \begin{array}{l} \left( \begin{array}{c} - \left( \begin{array}{c} +NM \\ +spkr \end{array} \right) \end{array} \right) \\ \left( \begin{array}{c} - \left( \begin{array}{c} +NM \\ -plur \end{array} \right) \end{array} \right) \\ \left( \begin{array}{c} - \left( \begin{array}{c} +NM \\ -spkr \end{array} \right) \end{array} \right) \end{array} \right\}$	→	$\left( \begin{array}{c} - \left( \begin{array}{c} +NM \\ \pm addr \end{array} \right) \end{array} \right)$
IRR-15	$\left( \begin{array}{c} - \left( \begin{array}{c} +NM \\ +plur \end{array} \right) \\ - \left( \begin{array}{c} +NM \\ -addr \end{array} \right) \end{array} \right)$	→	$\left( \begin{array}{c} - \left( \begin{array}{c} +NM \\ +spkr \end{array} \right) \end{array} \right)$

In effect, these rules state that the lexical representation (lexeme) of every Mono-Alu verb is actually an abbreviation for 14 inflected forms (words). Every lexeme marked [+PAT] can take any of 14 (7[person] x 2[tense]) alternative forms.

These inflectional features are represented morphologically by verb prefixes. Rules IRR-16 through IRR-29 associate the correct agreement prefix with a verb stem by referring to the contextual features assigned by rules SR-28 through SR-30.

IRR-16	[	→	[ fai 1s:nfut	/	$\left( \begin{array}{c} -fut \\ - \left( \begin{array}{c} +NM \\ +plur \end{array} \right) \\ - \left( \begin{array}{c} +NM \\ -spkr \end{array} \right) \end{array} \right)$
IRR-17	[	→	[ fana 1s:fut	/	$\left( \begin{array}{c} +fut \\ - \left( \begin{array}{c} +NM \\ +plur \end{array} \right) \\ - \left( \begin{array}{c} +NM \\ -spkr \end{array} \right) \end{array} \right)$
IRR-18	[	→	[ oi 2s:nfut	/	$\left( \begin{array}{c} -fut \\ - \left( \begin{array}{c} +NM \\ +plur \end{array} \right) \\ - \left( \begin{array}{c} +NM \\ -addr \end{array} \right) \end{array} \right)$
IRR-19	[	→	[ ona 2s:fut	/	$\left( \begin{array}{c} +fut \\ - \left( \begin{array}{c} +NM \\ +plur \end{array} \right) \\ - \left( \begin{array}{c} +NM \\ -addr \end{array} \right) \end{array} \right)$



IRR-20	[	→	[ i 3s:nfut	/	[-fut -(+NM +plur) -(+NM +spkr) -(+NM +addr)]
IRR-21	[	→	[ ena 3s:fut	/	[+fut -(+NM +plur) -(+NM +spkr) -(+NM +addr)]
IRR-22	[	→	[ tai lpI:nfut	/	[-fut -(+NM -plur) -(+NM -spkr) -(+NM -addr)]
IRR-23	[	→	[ tara lpI:fut	/	[+fut -(+NM -plur) -(+NM -spkr) -(+NM -addr)]
IRR-24	[	→	[ ami lpE:nfut	/	[-fut -(+NM -plur) -(+NM -spkr) -(+NM +addr)]
IRR-25	[	→	[ ama lpE:fut	/	[+fut -(+NM -plur) -(+NM -spkr) -(+NM +addr)]

IRR-26	[	→	[ ang 2p:nfut	/	$\left( \begin{array}{l} -\text{fut} \\ -\left( \begin{array}{l} +\text{NM} \\ -\text{plur} \end{array} \right) \\ -\left( \begin{array}{l} +\text{NM} \\ +\text{spkr} \end{array} \right) \\ -\left( \begin{array}{l} +\text{NM} \\ -\text{addr} \end{array} \right) \end{array} \right)$
IRR-27	[	→	[ emia 2p:fut	/	$\left( \begin{array}{l} +\text{fut} \\ -\left( \begin{array}{l} +\text{NM} \\ -\text{plur} \end{array} \right) \\ -\left( \begin{array}{l} +\text{NM} \\ +\text{spkr} \end{array} \right) \\ -\left( \begin{array}{l} +\text{NM} \\ -\text{addr} \end{array} \right) \end{array} \right)$
IRR-28	[	→	$\left\{ \begin{array}{l} \text{iri} \\ \text{re} \end{array} \right.$ 3p:nfut	/	$\left( \begin{array}{l} -\text{fut} \\ -\left( \begin{array}{l} +\text{NM} \\ -\text{plur} \end{array} \right) \\ -\left( \begin{array}{l} +\text{NM} \\ +\text{spkr} \end{array} \right) \\ -\left( \begin{array}{l} +\text{NM} \\ +\text{addr} \end{array} \right) \end{array} \right)$
IRR-29	[	→	$\left\{ \begin{array}{l} \text{eria} \\ \text{rea} \end{array} \right.$ 3p:fut	/	$\left( \begin{array}{l} +\text{fut} \\ -\left( \begin{array}{l} +\text{NM} \\ -\text{plur} \end{array} \right) \\ -\left( \begin{array}{l} +\text{NM} \\ +\text{spkr} \end{array} \right) \\ -\left( \begin{array}{l} +\text{NM} \\ +\text{addr} \end{array} \right) \end{array} \right)$

Notice that there are two prefixes for both third person plural non-future (3p:nfut) and third person plural future (3p:fut). As explained in section 5.3.1.1, there is not sufficient evidence in the texts to explain the occurrence of these variant forms.

As specified by the features assigned by these rules, a sentence such as (T37) is well formed, but (T38) is not.

(T37)

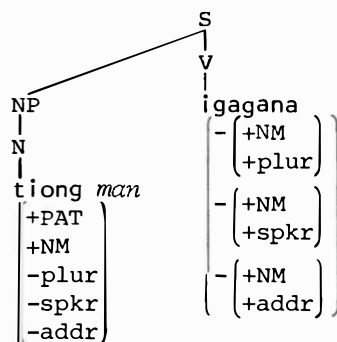

(T38)

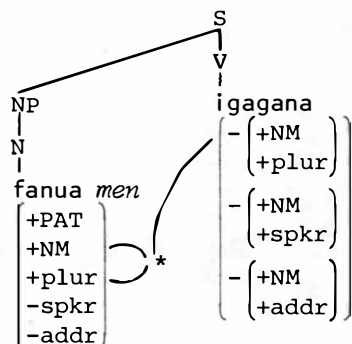

Structure (T38) is not well formed because the indicated features of *gagana* and *fanua* are incompatible.

Consider, however, structure (T39) in which the contextual features of the verb and the person and number features of the Patient are identical to (T38).

(T39)

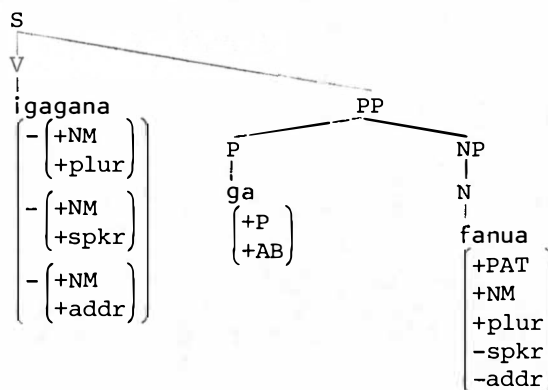

As explained above, the case form of the noun in an exocentric construction (like the prepositional phrase in T39) is determined by the case form of the lexical head of the construction (the preposition *ga* in T39). The Patient case relation in (T39) is therefore realised by the absolutive [+AB] case form, not the nominative [+NM] case form. The contextual features of the verb thus have no control over the person and number of the Patient since the contextual features can refer only to nominative actants.

As the features are stated in (T39), the sentence is technically well formed even though the verb prefix is singular and the Patient is plural. This situation can be remedied by assigning contextual features to the verb which refer to an absolutive actant with person and number features identical to those which refer to a nominative actant.

Rule IRR-30 assigns such features to intransitive verbs.

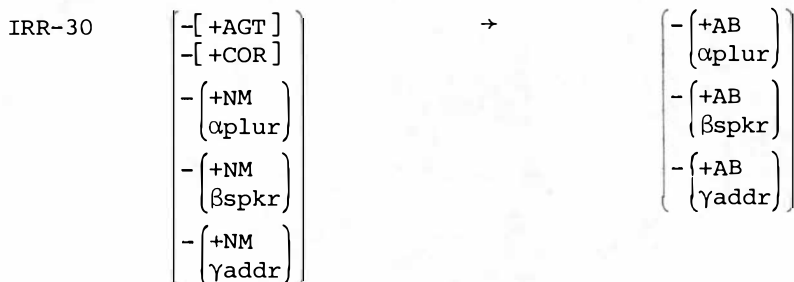

After application of this rule, structure (T39) must be revised as shown in structure (T40).

(T40)

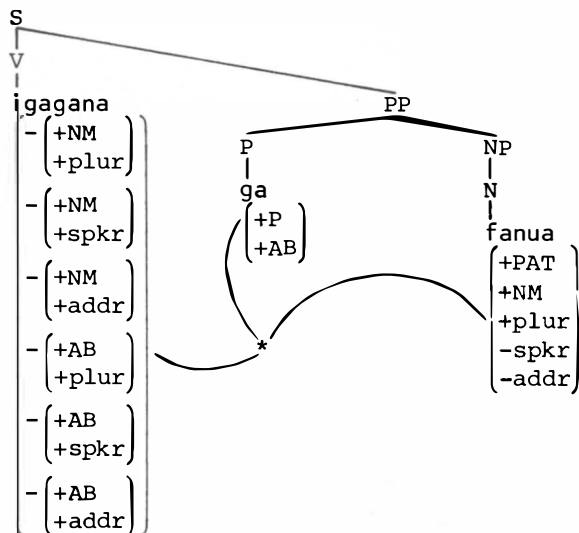

The features introduced by IRR-30 produce the effect of making (T40) ill formed since *fanua*'s [+plur] together with *ga*'s [+AB], violate the indicated contextual features of the verb.

The contextual features which refer to nominative actants still trigger the application of morphophonemic rules which attach the verb prefixes. The absolutive contextual features assure that an absolutive actant has person and number features that do not conflict with the nominative ones.

(T41)

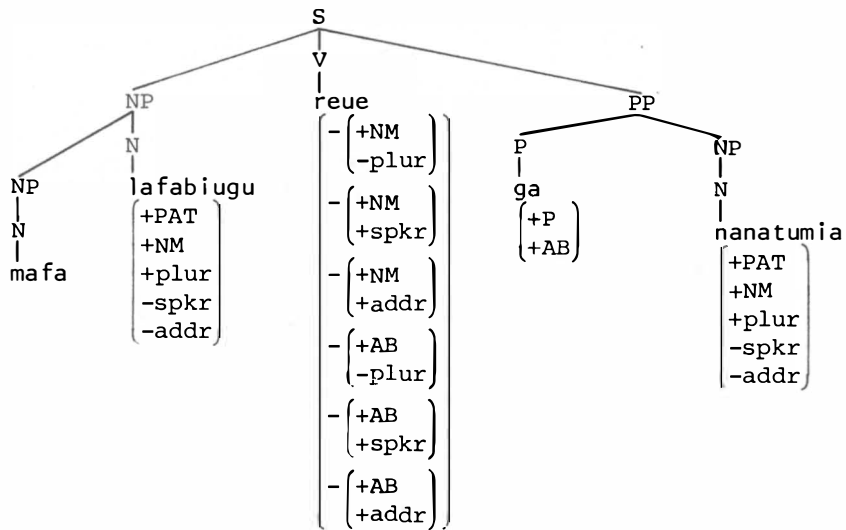

1172      mafa   la-fabiu-gu      re-ue      eta  
 9h      ls   pl-grandchild-ls:pssv   3p:nfut-run  
 ga   na-natu-mia  
 abs pl-daughter-2p:pssv  
 my grandchildren, your daughters, have run off

Notice also that this system of specifying agreement leaves open the possibility that a single sentence could contain two co-referential actants in the Patient case relation, one realised by the nominative case form, and one by the absolutive case form. Such sentences do, in fact, occur in Mono-Alu, as evidenced by sentence 1172, shown in structure (T41).

A rule analogous to IRR-30 is also necessary for transitive verbs. That rule, however, states a relationship between accusative and absolutive actants rather than nominative and absolutive actants.

As discussed in section 5.3, Mono-Alu's marker of the accusative case form [+AC] is verb suffix agreement. The same formal procedure is used to specify suffix agreement as was used above for prefix agreement. Verb suffixes occur only with transitive verbs, however, so the rules which assign contextual features for suffix agreement apply only to transitive verbs. Rules SR-31 through IRR-32 assign contextual features to transitive verbs, and IRR-33 through IRR-38 specify the relationship between contextual features and verb suffixes.

SR-31	$\left( \begin{array}{c} - (+PAT) \\ (+NM) \end{array} \right)$	→		$\left( \begin{array}{c} - (+AC \\ \pm plur) \\ - (+AC \\ \pm spkr) \end{array} \right)$
IRR-31	$\left( \begin{array}{c} - (+AC \\ + plur) \\ - (+AC \\ - spkr) \end{array} \right)$	→		$\left( \begin{array}{c} - (+AC \\ + addr) \end{array} \right)$
SR-32	$\left\{ \begin{array}{c} \left( \begin{array}{c} - (+AC \\ + spkr) \end{array} \right) \\ \left( \begin{array}{c} - (+AC \\ - plur) \end{array} \right) \\ \left( \begin{array}{c} - (+AC \\ - spkr) \end{array} \right) \end{array} \right\}$	→		$\left( \begin{array}{c} - (+AC \\ \pm addr) \end{array} \right)$
IRR-32	$\left( \begin{array}{c} - (+AC \\ + plur) \\ - (+AC \\ - addr) \end{array} \right)$	→		$\left( \begin{array}{c} - (+AC \\ + spkr) \end{array} \right)$
IRR-33	]	→	afa] 1s	/ $\left( \begin{array}{c} - (+AC \\ + plur) \\ - (+AC \\ - spkr) \end{array} \right)$
IRR-34	]	→	o] 2s	/ $\left( \begin{array}{c} - (+AC \\ + plur) \\ - (+AC \\ - addr) \end{array} \right)$

IRR-35	]	→	ita] lpI	/	$\begin{pmatrix} - (+AC) \\ - (-plur) \\ - (+AC) \\ - (-spkr) \\ - (+AC) \\ - (-addr) \end{pmatrix}$
IRR-36	]	→	ami] lpE	/	$\begin{pmatrix} - (+AC) \\ - (-plur) \\ - (+AC) \\ - (-spkr) \\ - (+AC) \\ - (+addr) \end{pmatrix}$
IRR-37	]	→	ang] 2p	/	$\begin{pmatrix} - (+AC) \\ - (-plur) \\ - (+AC) \\ - (+spkr) \\ - (+AC) \\ - (-addr) \end{pmatrix}$
IRR-38	]	→	ri] 3p	/	$\begin{pmatrix} - (+AC) \\ - (-plur) \\ - (+AC) \\ - (+spkr) \\ - (+AC) \\ - (+addr) \end{pmatrix}$

Rule IRR-39 does for transitive verbs what IRR-30 does for intransitive verbs. That is, it assures that absolutive Patients in transitive sentences agree in person and number with verb suffixes.

IRR-39	$\begin{pmatrix} - (+AC) \\ (\alpha plur) \\ - (+AC) \\ (\beta spkr) \\ - (+AC) \\ (\gamma addr) \end{pmatrix}$	→	$\begin{pmatrix} - (+AB) \\ (\alpha plur) \\ - (+AB) \\ (\beta spkr) \\ - (+AB) \\ (\gamma addr) \end{pmatrix}$
--------	---	---	---

### 6.3 Subcategorisation and redundancy rules for prepositions and postpositions

In this analysis, prepositions and postpositions are considered to be members of a single syntactic class [+P]. The two first order members of this class are distinguished by the fact that prepositions precede nouns and postpositions follow nouns.

SR-33	[+P]	→	$\begin{pmatrix} \pm [+N] \\ \pm L \end{pmatrix}$
-------	------	---	---

Members of the lexical class [+P] can either occur after nouns or not. That is, they are either postpositions [+ [+N]\_\_\_] or prepositions [- [+N]\_\_\_]. In addition, they either mark the locative case form [+L], or not [-L].

$$\text{SR-34} \quad \left( \begin{array}{c} +[+N] \text{___} \\ +L \end{array} \right) \rightarrow [+a\# \text{___}]$$

Rule SR-34 states that there are two functionally identical locative postpositions, the distributions of which are phonologically conditioned. The locative postposition *at*, *in* cannot follow a noun which ends in *a*, and thus carries the feature [-a#\_\_\_]. The locative postposition *ang*, with the same meaning, always occurs after a noun which ends in *a*, and thus carries the feature [+a#\_\_\_].

Both of these postpositions carry the semantic feature [-src] (non-source) since they do not indicate that the location named by the associated noun is the source of the activity described by the verb (see section 5.3.2.2). Rule RR-21 adds this feature to these lexical items.

$$\text{RR-21} \quad \left( \begin{array}{c} +[+N] \text{___} \\ +L \end{array} \right) \rightarrow [-\text{src}]$$

The non-locative postposition *ua with* is Mono-Alu's marker of the comitative case form [+CM], and is thus assigned that case form feature by rule RR-22.

$$\text{RR-22} \quad \left( \begin{array}{c} +[+N] \text{___} \\ -L \end{array} \right) \rightarrow [+CM]$$

The locative preposition *tiga from* indicates that the location named by the associated noun is the source of the activity or event described by the verb. This function is represented formally by the semantic feature [+src] (source) which is assigned by rule RR-23.

$$\text{RR-23} \quad \left( \begin{array}{c} -[+N] \text{___} \\ +L \end{array} \right) \rightarrow [+src]$$

Rule SR-35 divides non-locative prepositions into two classes: one which marks the instrumental case relation [+I], and one that does not. The preposition *ena with* carries the case form feature [+I].

$$\text{SR-35} \quad \left( \begin{array}{c} -[+N] \text{___} \\ -L \end{array} \right) \rightarrow [+I]$$

As specified by rule RR-24, the non-instrumental preposition *ga* carries the case form feature [+AB]. *ga* is Mono-Alu's marker of the absolutive case form.

$$\text{RR-24} \quad [-I] \rightarrow [+AB]$$

Some redundancies can be extracted from this subcategorisation which provide for simpler lexical entries for pre- and postpositions.

$$\text{RR-25} \quad [+I] \rightarrow \left( \begin{array}{c} -[+N] \text{___} \\ -L \end{array} \right)$$

$$\text{RR-26} \quad [+L] \rightarrow [+P]$$

In order to fully specify the allowable syntactic distribution of members of the lexical category [+P] it is necessary that they each carry certain other contextual features. These features are assigned by rules RR-27 through RR-31, and are complemented by other features assigned by the 'omega rule' (see section 6.4).

$$\text{RR-27} \quad [-[+N] \text{___}] \rightarrow [+ \text{___} [+N]]$$

This rule states that all prepositions must occur before a noun, and prevents the omega rule (section 6.4) from assigning these items the feature [-\_\_[+N]]. If the omega rule were allowed to add this feature, prepositions would not be allowed to have any nominal sister constituents.

Notice that the omega rule will add the feature [-\_\_[+N]] to all postpositions, and will thereby correctly prevent them from having nominal sisters to the right. In addition, the omega rule will add the features [-\_\_[+P], -[+P]\_\_] to all pre- and postpositions, correctly preventing a single noun phrase from occurring in association with both a preposition and a postposition.

It is necessary to assure that locative pre- and postpositions occur only in association with actants in the Locus and Place case relations. Rules SR-36 and RR-28 formally specify this distribution.

SR-36	[+L]	→	[±[+LOC]]
RR-28	$\left\{ \begin{array}{l} +L \\ -[+LOC] \end{array} \right\}$	→	[+[+PLC]]

Given these features, the omega rule will add further features which provide that these lexical items cannot occur with actants in the Patient, Agent, Correspondent, Reference, Instrument, or Concomitant case relations.

Rule RR-29, again in conjunction with the omega rule, states that the comitative postposition *ua with* can occur only with an actant in the Concomitant case relation.

RR-29	[+CM]	→	[+[+CON]]
-------	-------	---	-----------

Rules RR-30 and RR-31 perform a similar function for the instrumental preposition *ena with* and the absolutive preposition *ga*.

RR-30	[+I]	→	[+[+INS]]
RR-31	[+AB]	→	[+[+PAT]]

Figure 19 illustrates the feature combinations of the lexical categories defined by rules SR-33 through RR-24.

#### 6.4 The omega rule

As explained by Starosta (1978:4-5), phrase structure rules are not needed in a lexibase grammar provided that the grammar contains a special (perhaps universal) inflectional redundancy rule called the *omega rule*.

Such a rule, which is adequate to account for the aspects of Mono-Alu grammar discussed in this study, is given below as IRR-40. This rule must necessarily be the last redundancy rule to apply to any lexical item.

IRR-40	[ ]	→	$\left\{ \begin{array}{l} -[+N] \\ -[+V] \\ -[+P] \\ -[+det] \\ -[+PAT] \\ -[+AGT] \\ -[+COR] \\ -[+REF] \\ -[+LOC] \\ -[+PLC] \\ -[+INS] \\ -[+CON] \end{array} \right\}$
--------	-----	---	--



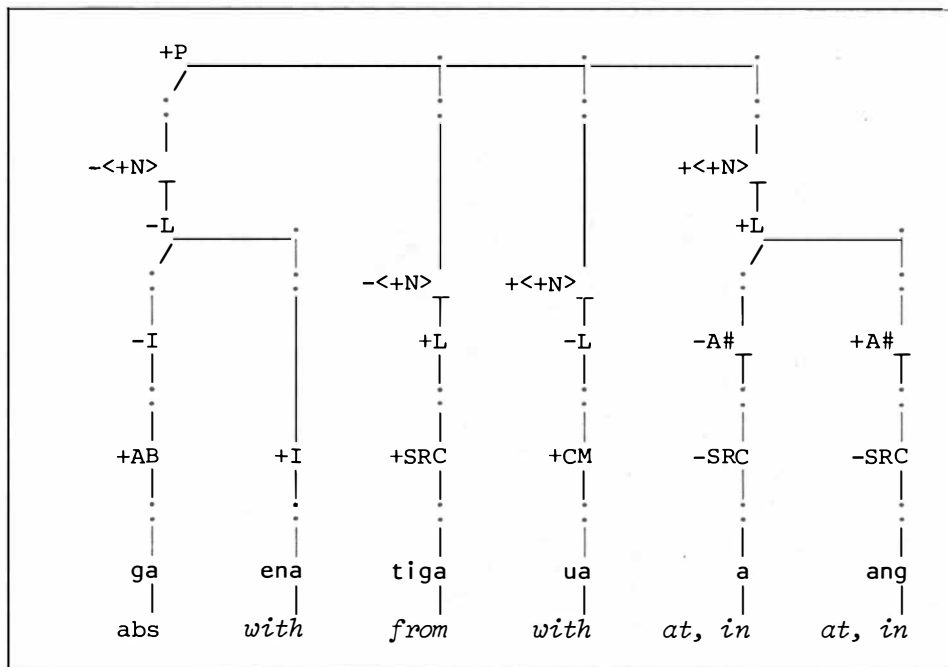

Figure 19: Feature combinations for prepositions and postpositions

Unless otherwise restricted, this rule would have the effect of stating that all lexical items can have no sister constituents of any kind either to the left or to the right. That is, all well formed constructions would consist of a single lexical item. The positively specified features carried by a particular lexical item have the effect of marking that lexical item as an exception to part of the omega rule. For example, if an item is lexically specified [+PAT], this positive specification for the Patient case relation makes it impossible for the omega rule (or for that matter any redundancy rule) to add a contradictory feature.

It is important to note that a feature of the form [-[+N]] is an abbreviation for the two features [-[+N]\_\_\_] and [-\_\_\_[+N]]. Thus if a lexical item (such as a postposition, Figure 19) carries the feature [+ [+N]\_\_\_] the omega rule will assign it the feature [-\_\_\_[+N]], but not the contradictory feature [-[+N]\_\_\_].

The function of the omega rule can be illustrated by considering how it applies to the Mono-Alu preposition *ga*, in conjunction with other redundancy rules which apply before it. In its lexical form, *ga* carries the single syntactic feature [-I]. This is its only non-redundant feature. All other features relevant to its syntactic distribution can be predicted from this feature by the redundancy rules discussed in section 6.3 together with the omega rule (IRR-40).

The fully specified form of *ga*, after the application of all relevant redundancy rules is given below in (2). The rule that assigns each redundant feature is listed to the right of the feature matrix.



CASE FORM	CASE MARKER				CASE RELATION							
	Verb Agrmt	Prep	Postp	None	PAT	AGT	COR	REF	LOC	PLC	INS	CON
+AB		ga			A							
+NM	px				B	C	D					
+AC	sfx				E							
-AC				X				F			G	
+L		tiga	a ang						H	I		
+CM			ua									J
+I		ena									K	

Figure 20: Case relations, case forms, and case markers  
Capital letters (except X) refer to sentence examples given in this section

B.

4289 fanua iri-gagana famata ang  
41x men 3p:nfut-go village loc  
(+PAT) [+LOC] [+L]  
(+NM)  
*the men went to their village*

C.

698 mafa fai-lapu-lapu-ri ita ga episa  
7c ls 1s:nfut-kill-kill-3p ? abs three  
(+AGT) [+AB] [+PAT]  
(+NM)  
*I have killed three*

D.

928 mafa fana-roro-i ama ga mamaifa  
8g ls 1s:fut-see-tr dir abs chiefly:woman  
(+COR) [+AB] [+PAT]  
(+NM)  
*I will look at the chief's woman*

E.

4560 mani suma i-gasu-ami ma  
46e lpE bone 3s:nfut-drive:away-lpE dir  
(+PAT) (+AGT)  
(+AC) (+NM)  
*the bones have driven us away*

## F.

- 988 i-golu pipilua ga mamaifa  
 8m 3s:nfut-eat human bodies abs chiefly:woman  
 (+REF) [+AB] [+PAT]  
 (-AC)  
*the chiefly woman ate the human bodies*

## G.

- 3781 batafa i-tele ga nife tapoina rarami  
 37d woman 3s:nfut-give abs snake much food  
 (+AGT) [+AB] [+PAT] (+INS)  
 (+NM) (-AC)  
*the woman gave the snake plenty of food*

## H.

- 6330 emia-roro-i ga rarami tia-na ang aroaro  
 66r 2p:fut-see-tr abs food belly-3s:pssv loc basket  
 [+AB] [+PAT] [+LOC] [+L]  
*(you will) look at the food inside the baskets*

## I.

- 2423 ona-roro-i ga sa-ma numa tiga kai  
 20c 2s:fut-see-tr abs thing-lpE:pssv house from tree  
 [+AB] [+PAT] [+L] [+PLC]  
*you will see our house from the kai tree*

## J.

- 2022 mani sa-gu tala ua nife sa-na  
 16k lpE thing-1s:pssv men with snake thing-3s:pssv  
 (+PAT) [+CON] [+CM] [+LOC]  
 (+NM)  
 famata ang ami-gagana  
 village loc lpE:nfut-go  
 [+L]  
*I and my men are going to the snake's abode*

## K.

- 5314 iri-lafa-i ena mua  
 52m 3p:nfut-hit-tr with club  
 [+I] [+INS]  
*they beat him with clubs*

## CHAPTER 7

### CONCLUDING REMARKS

#### 7. INTRODUCTION

This chapter has been included in order to provide a place for a few brief, and rather informal, statements with regard to two issues: (1) further research on Mono-Alu, and (2) the extent to which the lexicase formalisation presented in chapter 6 accurately reflects the unformalised segment of the analysis presented in chapters 2-5. In relation to this, an alternative analysis of case marking in Mono-Alu is outlined briefly.

##### 7.1 Future research on Mono-Alu

Because of the preliminary nature of this study and the limited data available, a significant amount of research is still needed before a reasonably complete analysis of Mono-Alu grammar can be made. Certain aspects of syntax could be investigated further using the data which is currently available. However, the ideal situation – one which would certainly result in a more complete and accurate description – would be to base further analysis on data collected in the field. As explained in the introductory chapter, one of the objectives of the present study has been to provide a preliminary analysis of Mono-Alu syntax which could be used as a basis for planning a field study of the language.

Some of the aspects of Mono-Alu grammar listed in the following paragraphs have not been touched on in the present study. Others have been discussed, but only superficially. All of them, including the topics analysed in greater detail in the preceding chapters, could benefit greatly from further study – especially if based on additional data.

**PHONETICS AND PHONOLOGY.** Almost nothing is known about the phonetics and phonology of Mono-Alu. Though Wheeler's transcription uses standard symbols for the most part, the precise phonetic value of some of them is unknown (for example his symbol 'n). Also, the factors (if any) which condition the occurrence of certain variant forms cannot be determined from the texts alone. This appears to be true for the sets b:v, d:r:dr, and f:h. Variation in the form of final nasals (which doesn't appear to be a case of simple assimilation to a following consonant) also deserves further study. The meaning of Wheeler's diacritics on vowels is also unknown, and it is unclear whether they indicate a phonemic distinction.

A better understanding of phonetics and phonology may also help answer questions about variation in the form of a number of lexical items and grammatical morphemes encountered in the texts.

**VERB MORPHOLOGY.** Several verb affixes will require considerable further investigation in order to determine their functions more accurately.

**INFLECTIONAL PREFIXES.** To begin with, the accuracy of Wheeler's future versus non-future distinction indicated by the two series of inflectional prefixes should be checked. As mentioned in section 5.3.1.1 irrealis versus realis may be more appropriate than future versus non-future. Also, Wheeler's glosses suggest nothing about possible distinctions in meaning indicated by alternate forms of the third person plural prefixes *iri/re* (non-future) and *eria/rea* (future).

In a few isolated sentences, the verb carries the portion of the prefix which indicates person and number without the portion which indicates future versus non-future; for example *fa-gagana* or *o-gagana* rather than the usual *fana-gagana* *I will go* or *ona-gagana* *you will go*. Again the contrast in meaning between these forms is not clear.

**DERIVATIONAL AFFIXES.** All of the derivational prefixes mentioned in the introductory chapter (section 1.2.2.2), as well as reduplication of verb bases, are in need of further study. Most of these are not well represented in the texts, and in some cases the glosses indicate a certain amount of variation in meaning.

The transitive suffix *i* is well represented in the texts, but the extent to which it can productively derive transitive verbs from bases is uncertain. And, as is often the case with derivational processes, the semantic relationship between the derived and underived forms does not appear to be consistent.

In contrast to *i*, the transitive suffix *ng* is not well represented in the texts, and its semantic value is even more indeterminate than that of *i*. One verb (*galo carry*) suggests that a single base can be transitivised with either suffix, resulting in a corresponding distinction in meaning (see section 5.4.2). A better understanding of the semantics of these derivations could be obtained by undertaking a controlled study of the contrast in meaning between an underived base, its *i*-transitive, and its *ng*-transitive counterparts.

**OTHER VERB-RELATED MORPHEMES.** The three forms *ma*, *ai*, and *ata* often follow an inflected verb, but are never separated from the verb by any other sentence constituents.

Wheeler's glosses for *ma* and his commentary in notes to the texts indicate clearly that *ma* carries a component of meaning related to direction and/or motion.

It is difficult, however, to assign a more precise meaning, since the form seems to indicate both source and non-source directional movement and occurs with verbs of motion as well as non-motion verbs. Wheeler says that *ama* is an alternate form of *ma*, but there is no obvious phonological explanation for the variation in form. It may be the case that *ama* is a different morpheme with a distinct (though perhaps still directional) meaning.

The form *ata*, (with variant forms *eta*, *ita*, *ota*, *uta*, depending on the form of the preceding vowel) also occurs following inflected verbs. Its meaning is not so much as hinted at by Wheeler's glosses, and its infrequent appearance

in the texts makes it difficult to draw any conclusions about its function from its distribution. Notes to the texts (42h3, 64c6, 67c6) suggest, however, that its meaning may be related to tense or mode.

**DETERMINERS.** As is evident from the discussion of determiners in section 3.1.1 the grammatical status and meaning of all the forms discussed there is very much in question. A study of their occurrence in different speech contexts and discourse situations may lead to a better understanding of their grammatical functions and meanings.

**ATTRIBUTES OF NOUNS.** Considerable further study of the constituent structure of complex noun phrases and the grammatical status of forms which function as attributes of nouns is definitely needed. The analysis of such constructions presented in chapter 3 is of a very preliminary nature and would benefit greatly from further investigation.

**GRAMMATICAL STATUS OF ga.** Chapters 4 and 5 described some reasonably consistent patterns with regard to the distribution and function of *ga*. Most of the evidence suggests that it consistently precedes an actant in the Patient case relation when the Patient occurs to the right of the predicate. This is true of both verbal and non-verbal predicates.

*ga*'s consistent association with nouns, and its position with respect to nouns argues in favour of the conclusion that it is a preposition. There is evidence, however, which indicates that *ga* may be a noun. Starosta (personal communication) has pointed out that the fact that *ga* sometimes carries suffixes which indicate the person and number of the subject in equational sentences (section 4.1.2) suggests that it is a noun.

Though the conclusions drawn with regard to the case marking function of *ga* appear to be quite reliable, a more thorough investigation (based on additional data) of its distribution and meaning will lead to a more accurate understanding of its syntactic function and grammatical status.

**POSSESSIVES WITH UNINFLECTED VERB STEMS.** Forms which occur as inflected verbs also occur in other sentence types without inflectional affixes, and followed by *sa* or *e* possessives. The uninflected forms are often reduplicated, and have the meaning that the action or state occurs repeatedly, or over an extended period of time. Some examples of both of these are:

Inflected	Uninflected
1. (a) <i>rea-gagana saiga ang</i> 3p:fut-go garden loc <i>they went to the garden</i>	(b) <i>gagana sa-ria</i> <i>go thing-3p:pssv</i> <i>on they went</i> <i>(their going)</i>
2. (a) <i>mani ami-golu ga boo</i> lpE lpE:nfut-eat abs pig <i>we ate the pig's flesh</i>	(b) <i>mafa abu gogolu sa-gu</i> ls neg eat thing-my <i>I do not eat</i> <i>(my not eating)</i>

Since the forms in (b) sentences are uninflected and occur with possessives, it seems likely that they are nouns rather than verbs, as in the type (a) sentences. The relationship between the two forms is derivational, but the direction of derivation (N to V or V to N) is not clear, though the reduplicated form is more likely to be the derived one. If these forms are treated as nouns, the type (b) sentences are similar in form to some of the *sa* and *e* possessive constructions discussed in chapter 2.

Though this study does not discuss these constructions, a more complete description of the language should include an analysis of them.

WORD ORDER. As can be seen from the discussion of possessive constructions in chapter 2 and verbal constructions in section 5.3, word order of nominal constituents with respect to each other and with respect to the verb is highly variable. It has been possible to recognise a few general tendencies, however.

A controlled study of word order designed with the objective of determining the possible case marking function of word order would be beneficial.

LEXICON. Many of the lexical items in Wheeler's tests are poorly represented, and thus many of their meanings are uncertain. The glosses of these and all other lexical items in the texts should be checked for accuracy.

QUESTIONS. The form of questions in Mono-Alu has not been analysed in this study, except to the extent that the use of the interrogative pronouns *fina where* and *ale who* was mentioned. Two related forms, *afaua* and *afa* are also associated with questions. Though constructions which make use of these forms have not been thoroughly analysed, it appears that *afaua* is a verb, since it occurs with inflectional prefixes.

NEGATIVES. The present study has not investigated the syntax of negation, but it has been observed that several forms occur in association with a negative meaning. These include *abu*, *aia*, *ape*, *apea*, *apeai*, *ate*, *ati*, and *bau*. Future research on negation should be concerned with determining the grammatical status of these forms and their distribution with respect to other sentence constituents.

COMPARATIVE WORK. A comparative study of the grammatical structures of Mono-Alu and those of geographically adjacent Austronesian languages may contribute to a better understanding of the syntax of the language. Comparative study of both phonology and syntax will, of course, be helpful in determining the relationships among Mono-Alu and neighbouring languages, and may provide information which will contribute to the continuing efforts to reconstruct proto-Oceanic or lower-order proto-languages of the Oceanic group.

## 7.2 An alternative analysis of case marking

The analysis of case marking presented in section 5.3 accepts several things as given. These include:

- (1) the eight case relations defined in section 5.1.1,
- (2) the proposal that there is a finite number of adequately defined case forms which realise those case relations, and
- (3) the assumption that an analyst can consistently determine (a) what case relation each actant in a sentence is in, (b) what case form realises each case relation under different syntactic circumstances, and (c) what language specific syntactic device (case marker) signals the presence of each case form.

The case relations relevant to the current discussion are Agent [+AGT], Correspondent [+COR], and Patient [+PAT]; relevant case forms are absolutive [+AB], nominative [+NM], and accusative [+AC].



In conjunction with traditional definitions of two well-known case marking systems, accusative and ergative, and the traditional definitions of the three case forms given in the preceding paragraph, the data provided by Wheeler's texts led to the conclusion that Mono-Alu's case marking system exhibits characteristics of both an ergative and an accusative case marking system. That is, it is possible to recognise three syntactic devices in Mono-Alu verbal constructions, the distributions of which are characteristic of case markers of the three case forms absolutive, nominative, and accusative. The distribution of *ga* is characteristic of a marker of the absolutive case form. The pattern of verb prefix agreement is characteristic of a marker of the nominative case form, and the pattern of verb suffix agreement is characteristic of a marker of the accusative case form. The data thus suggest that an adequate analysis of the case marking system should recognise that the distribution of these markers is characteristic of three common case forms. For this reason, these markers have been analysed as case markers of the case forms absolutive, nominative, and accusative.

It was observed further in section 5.3 that in two construction types the markers of two case forms coincide when they are associated with the actant in the Patient case relation. Thus it was concluded that in certain intransitive sentences the Patient is realised by both the nominative and absolutive case forms and that in certain transitive sentences the Patient is realised by both the absolutive and accusative case forms.

Though this distribution of case markers may be somewhat unusual, the patterns recognised are consistent with the data, and are certainly significant patterns that deserve explicit recognition in an analysis of the case marking system.

Recognising these patterns of case marking in unformalised prose statements, such as section 5.3, is fairly straightforward. The mechanisms and conventions used in a lexicase formalisation of the correspondence between case forms and case relations, however, make it impossible to construct a formal syntactic representation of a sentence in which a single actant is realised by more than one case form. Thus the patterns of case marking exhibited by the data and explained in the unformalised segment of the analysis cannot be duplicated accurately in the formal segment of the analysis.

This situation is a result of the fact that both nouns and prepositions carry case form features, and the convention (see section 6.2 and De Guzman 1976:73-74) that in an exocentric construction the case form of a lexical head takes precedence over the case form of a non-lexical head. Due to this convention, an actant which is a prepositional phrase is realised by the case form of its lexical head (for example *ga* [+P,+AB]) rather than its non-lexical head, a noun carrying, for example, the features [+PAT,+NM].

This convention has both positive and negative effects on the formal statement of Mono-Alu case marking. The positive effect is that without this convention it would be impossible to assign contextual features to verbs which require that Patients are never marked by *ga* when preceding the verb but are always marked by *ga* when following the verb.

The negative effects of the convention are (1) that it makes it impossible to accurately reflect the well-supported unformalised analysis in a formal representation, and (2) it makes it necessary to introduce two additional (and somewhat ad hoc) redundancy rules (IRR-30, IRR-39) to assure that actants realised by the absolutive case form agree (in certain syntactic situations, see section 6.2) with verb affixes.

An alternative to this analysis has been suggested which avoids positing a mixed accusative-ergative case marking system, and avoids the conflict engendered by the proposal that more than one case form is associated with a single actant.

Starosta (personal communication) has suggested that Mono-Alu's case marking system is a purely ergative system. Like the analysis used in this study, his analysis would analyse *ga* as a marker of the absolutive case form (or nominative, equivalently and without conflict in a purely ergative system), which would realise the Patient case relation.

Verb prefix and suffix agreement, however, which were analysed as markers of *case forms* in this study would be analysed as markers of *case relations* in the alternative analysis. The alternative analysis does avoid the formal difficulties associated with the proposal that two case forms are associated with a single actant. There is, however, a legitimate objection to this alternative which is concerned with the syntactic status of case forms, and methods used to recognise markers of case forms during the process of analysing actual data.

As stated in the first paragraph of section 7.2, the analysis of Mono-Alu's case marking system as proposed in section 5.3 was based partly on the assumption that the inventory of case forms which realise case relations is finite and that each is defined in such a way that each can be recognised by an analyst of linguistic data.

In section 5.3 it was observed that the distribution of *ga*, verb prefix agreement, and verb suffix agreement were characteristic of markers of the absolutive, nominative and accusative case forms, respectively. Thus it was concluded that Mono-Alu's case marking system makes use of all three of these case forms. The alternative analysis, on the other hand, recognises the same patterns, but analyses *ga* as a marker of a case form, and prefix and suffix agreement as markers of case relations. There appears to be no justification for the proposal that the syntactic function of *ga* marking should be analysed as being distinct from the syntactic function of verb affix agreement. That is, there is no justification for the proposal that *ga* functions as a marker of a case form, while verb affix agreement functions as a marker of a case relation. Further, the alternative analysis fails to explicitly recognise the fact that the pattern of prefix and suffix agreement are characteristic of the distribution of the markers of two case forms which are well represented in a number of languages.

Certainly, both of these alternatives should be investigated more thoroughly before a final choice is made. No attempt will be made in the present work, however, to make this final choice. It seems likely, though, that a thorough investigation of the problem will have to consider and make explicit the formal status of case forms in lexicase theory, and will have to devise an appropriate methodology for determining whether a given syntactic device (such as prepositions or verb affix agreement) should be analysed as a marker of a case form, or as having some other syntactic function.

## ABBREVIATIONS

abs	absolutive	px	prefix
caus	causative	pron	pronoun
dem	demonstrative	pssd	possessed
det	determiner	pssr	possessor
dir	directional	pssv	possessive
fut	future	rel	relative clause marker
loc	location	sfx	suffix
neg	negative	stat	stative
nfut	non-future	tr	transitive
AB	absolutive case form	PAT	Patient case relation
AC	accusative case form	PLC	Place case relation
AGT	Agent case relation	REF	Reference case relation
CM	comitative case form	lpE	first person plural exclusive
CON	Concomitant case relation	lpI	first person plural inclusive
COR	Correspondent case relation	ls	first person singular
INS	Instrument case relation	2p	second person plural
L	locative case form	2s	second person singular
LOC	Locus case relation	3p	third person plural
NM	nominative case form	3s	third person singular

## NOTES

<sup>1</sup>Unless otherwise stated, all citations of Wheeler's work refer to Wheeler 1926.

<sup>2</sup>Care should be taken, however, to assure that such restrictions do not exclude alternative analyses which are simpler or more insightful, in some adequately defined sense, but which happen to violate the formal restrictions of the model.

<sup>3</sup>The form of a lexicase grammar has been described in detail in Starosta (n.d.a.) and summarised in Starosta (1978, esp. p.2-5). This discussion is based largely on these two sources.

<sup>4</sup>Hockett's terms 'grammatical pattern', 'tactical pattern', and 'morphophonemic pattern' and their definitions are analogous to the terms 'grammar', 'syntax', and 'morphology', as defined above. A significant difference between lexicase and Hockett's discussion of item and arrangement lies in the fact that item and arrangement deals with the distribution of morphemes (as well as words and more complex constituents), while lexicase is concerned with the distribution of words. A word, in a lexicase grammar, is anything that is not a derivational or inflectional affix.

<sup>5</sup>Section 3.2.1 proposed that the na final forms, if they are suffix-possessed nouns, would have to be construction heads rather than attributes. This approach is not, of course, applicable to the second set of modifiers. The current section is intended to be a more general discussion applicable to both classes of modifiers, given the possibility that further investigation might show that the na final forms cannot be confidently analysed as suffix-possessed nouns.

<sup>6</sup>There are a few exceptions to this general pattern. Of the 62 equational sentences of this type, seven of them have glosses which suggest that the order of subject and predicate is the reverse of the order proposed here.

- <sup>6a</sup>The sources of equational sentences containing ga are: 389 4b, 405 4b, 743 7f, 1463 12c, 1467 12c, 2344 18e, 2771 22d, 2960 27a, 3737 37b, 4543 46d, 5430 54e, 5466 54g, 6357 66u, 6367 66v, 6439 66dd, 6595 67h, 6738 67w.
- <sup>6b</sup>The sources of sentences in Figure 7 are: 227 3a, 722 7d, 723 7d, 742 7f, 746 7f, 1016 8o, 1247 9r, 2043 16m, 2442 20d, 2444 20d, 2719 22a, 2792 22f, 2977 27b, 3200 31d, 3285 33b, 3812 37g, 5389 54c, 5404 54c, 6028 65k, 6263 66h, 6549 67e, 6777 67z, 6822 67cc.
- <sup>7</sup> Though I will try to avoid the use of the terms 'subject' and 'object' in my own analysis of verbal constructions, it will still be necessary to use these terms when discussing the work of other scholars. Both terms will appear frequently in the summary of verbal constructions in Oceanic, section 5.2.
- <sup>7a</sup>The sources of examples in Figure 9 are:
- I(a): 1209 9n, 1285 9t, 2561 21f, 3276 33a, 3278 33a, 5558 57b, 6145 65v.  
 I(b): 1123 9f, 1225 9p, 1744 15b, 1926 16c, 4363 44a, 5084 50h, 5566 57b.  
 II: 105 1k, 753 7f, 1895 16b, 3877 39c, 4129 41n, 4756 48f, 4961 49f.
- <sup>8</sup> In the computer-generated illustrations of feature combinations, the asterisk indicates optionality. Thus \*<+PAT> is equivalent to +[[+PAT]].
- <sup>9</sup> The features [lapl] and [rdpl] are rule features. Because they are rule features the inflected forms which make use of them are merely notational variants for separate lexical items. These features have been used in this analysis because it has not been possible to isolate syntactic or semantic features which would make it possible to define the membership of the two classes. Further investigation may make it possible to define the membership of the classes without resorting to rule features.

## BIBLIOGRAPHY

BOCH, A.

- n.d. *A short Alu grammar*. South Pacific Commission. Preservation of manuscripts service. Deposit notice No.3. 20pp.

CHOMSKY, Noam

- 1965 *Aspects of the theory of syntax*. Tenth printing, May 1975. Cambridge, Massachusetts: The MIT Press.

DE GUZMAN, Videia P.

- 1976 The syntactic derivation of Tagalog verbs. Ph.D. dissertation, University of Hawaii.

FILLMORE, Charles J.

- 1968 The case for case. In Emmon Bach and Robert T. Harms, eds *Universals in linguistic theory*, 1-88. New York: Holt, Rinehart and Winston.

FOLEY, William Auguste

- 1976 Comparative syntax in Austronesian. Ph.D. dissertation, University of California at Berkeley.

GUNTHER, Hartmut

- 1975 Valency, case forms, and case relations. *University of Edinburgh Work in Progress* 8:64-83.

HARMON, Carol

- 1977 Kagayanen and the Manobo subgroup of the Philippine languages. Ph.D. dissertation, University of Hawaii.

HOCKETT, Charles F.

- 1958 *A course in modern linguistics*. Nineteenth printing. New York: Macmillan.

JACKENDOFF, Ray S.

- 1972 *Semantic interpretation in generative grammar*. Cambridge, Massachusetts: The MIT Press.

KULLAVANIJAYA, Pranee

- 1974 Transitive verbs in Thai. Ph.D. dissertation, University of Hawaii.

LINCOLN, Peter C.

- 1976a History of research in Austronesian languages: Bougainville Province. In Stephen A. Wurm, ed. *New Guinea area languages and language study*, vol.2: *Austronesian languages*. PL, C-39:197-222.

- 1976b Austronesian languages: Bougainville Province. In Stephen A. Wurm, ed. *New Guinea area languages and language study*, vol.2: *Austronesian languages*. PL, C-39:419-439.

LYNCH, John

- 1973 Verbal aspects of possession in Melanesian languages. *Oceanic Linguistics* 12:69-102.

- 1975 Oral nasal alternation and the realis/irrealis distinction in Oceanic languages. *Oceanic Linguistics* 14:87-99.

LYONS, John

- 1968 *Introduction to theoretical linguistics*. Cambridge: Cambridge University Press.

MATTHEWS, P.H.

- 1974 *Morphology: an introduction to the theory of word-structure*. Cambridge: Cambridge University Press.

MILNER, George B.

- 1976 Ergative and passive in Basque and Polynesian. *Oceanic Linguistics* 15:93-106.

PAWLEY, Andrew

- 1973 Some problems in Oceanic grammar. *Oceanic Linguistics* 12:103-188.

- 1978 Manuscript of Proto-Oceanic grammar distributed in University of Hawaii Department of Linguistics Seminar 760P: Problems in comparison and Prehistory: Oceanic. Spring semester 1978. Xeroxed.

PAWLEY, Andrew K., Lawrence A. REID, and Stanley STAROSTA

- 1978 The evolution of Philippine focus: out of the *\*fry-an* PAN and into the *\*i-fry*. 1978 Summer Meeting, Linguistic Society of America, University of Illinois, Urbana-Champaign, 28-30 July 1978. (Revised version, November 1978.)

PEARSON, Bruce L.

1977 *Introduction to linguistic concepts*. New York: Knopf.

QUIRK, Randolph, and Sidney GREENBAUM

1975 *A concise grammar of contemporary English*. New York: Harcourt Brace Jovanovich.

RAY, Sidney Herbert

1926 *A comparative study of the Melanesian island languages*. Cambridge: Cambridge University Press.

SOHN, Ho-Min

1973 Relative clause formation in Micronesian languages. *Oceanic Linguistics* 12:353-392.

STAROSTA, Stanley

1973 The faces of case. *Language Sciences* 25:1-14.

1976a Case forms and case relations in Sora. In P.N. Jenner, L.C. Thompson, and S. Starosta, eds *Austroasiatic studies*. *Oceanic Linguistics Special Publications* 13, Part II:1069-1108.

1976b A place for case. *Language Learning* 26:1-36.

1977 The one/sent solution. Workshop on Case Grammar and Valence Theory: 12th International Congress of Linguists, Vienna, August 29-September 2, 1977. Mimeographed. Slightly revised for circulation by Linguistic Agency University of Trier.

1978 Sora nouns: possession, compounding, and the lexical status of combining forms. Second International Congress on Austroasiatic Linguistics, Central Institute of Indian Languages. Mysore, December 19-21, 1978. Mimeographed.

n.d.a. Lexicase II: lexicon. Xeroxed, Department of Linguistics, University of Hawaii.

n.d.b. Generative syntax: a case approach. Xeroxed, Department of Linguistics, University of Hawaii.

SUGITA, Hiroshi

1973 Semitransitive verbs and object incorporation in Micronesian languages. *Oceanic Linguistics* 12:393-406.

WHEELER, Gerald Camden

1926 *Mono-Alu folklore (Bougainville Strait, Western Solomon Islands)*. London: George Routledge.