

**TEACHING ELECTRIC CIRCUITS IN GRADE 10  
PHYSICAL SCIENCE USING A CONCEPTUAL  
CHANGE APPROACH**

**Nomfundo Cynthea Fuzani**

**3081260**



Submitted in fulfillment of the requirements for the degree of

**UNIVERSITY of the  
Masters in Science Education**

in the Science Learning Centre for Africa of the Faculty of Education  
at the University of the Western Cape

**Supervisor:**

**Prof M.S. Hartley**

# Declaration

I, Nomfundo Cynthea Fuzani, declares that the work **TEACHING ELECTRIC CIRCUITS IN GRADE 10 PHYSICAL SCIENCE USING A CONCEPTUAL CHANGE APPROACH** is my own original work and has not been submitted to any other university for a degree. All sources have been fully acknowledged in the text and a list of references has been provided.

---

Nomfundo Cynthea Fuzani

---

Date



## ACKNOWLEDGEMENTS

*"I know the price of success: dedication, hard work and an unremitting devotion to the things you want to see happen."* - Frank Lloyd Wright.

- I therefore wish to express my sincere gratitude and appreciation to:-
- The Lord and my Saviour for granting me the knowledge, perseverance, courage and wisdom to pursue this study.
- Professor S. Hartley for his prompt, meticulous supervision and his tolerance and understanding.
- My Pastor July and his wife Nomanyano, for supporting me and encouraging to be strong and not giving up hope to succeed.
- My family, my wonderful sons Thabiso, Thabang and Thabo, for support, motivation and courage.
- My aunt, my brothers and friends for support throughout the study.
- A special thanks goes to my dear friend, who has been my source of strength and a shoulder to cry on. Without whose encouragement and support I doubt if I would have finished by now.
- A special thanks to my cousin brother and his wife for taking care of my baby while attending contact sessions and working towards completion of my thesis.

## TABLE OF CONTENT

DECLARATION	2
ACKNOWLEDGEMENTS	3
TABLE OF CONTENTS	4
ABSTRACT	7
Chapter 1: Rationale of the study	8
1.1 Introduction	8
1.2 Background to the study	8
1.2.1 Context of the study	12
1.3 State of Education in South Africa	14
1.4 Intervention in Science Education in the Eastern Cape	17
1.5 Research Problem	20
1.6 Research questions	21
1.7 Significance of the study	22
1.8 Limitations of the study	22
1.9 Structure of the thesis	22
1.10 Conclusion	23
Chapter 2: Literature Review	24
2.1 Introduction	24
2.2 Definitions of terms	24
2.3 Research question	24
2.4 Theoretical Framework	25
2.4.1 Constructivism	25
2.4.2 A Comparison of Traditional and Constructivist Approaches	30
2.4.3 Types of Constructivism	31
2.4.4 Social Constructivism	32
2.5 Conceptual Change Theory	36
2.6 Misconception	41
2.7 Studies based on Conceptual Change Approach	43
2.8 Related studies based on electric circuit	44



2.9 Conclusion	48
Chapter 3: Methodology	49
3.1 Introduction	49
3.2. Research Design	49
3.2.1 Case Study	50
3.2.2 The Research Sample	52
3.3 Data Collection Plan	52
3.4 Instruments	54
3.4.1 Pre – Test	54
3.4.2 Interview Schedule	55
3.4.3 Practical Investigation	56
3.4.4 Intervention Program	57
3.4.5 Pilot Study	59
3.4.6 Post Test	60
3.4.7 Focus Group Interview	60
3.5 Data analysis	63
3.6 Validation and Reliability	64
3.6.1. Validity	64
3.6.2 Reliability	64
3.7 Ethical considerations	65
3.8 Concluding remarks	65
Chapter 4: Findings	67
4.1 Introduction	67
4.2 What was the learner’s initial understanding of electric circuits?	67
4.3 Application of a Conceptual Change Approach	71
4.3.1 How was the conceptual change approach used to teach electric circuits?	71
4.4 What was learner’s understanding of electric circuits after the conceptual change lessons?	84
4.5 What were learners’ perceptions of the conceptual change approach to teaching?	86



4.5.1 Sadness and Fear	87
4.5.2 Doubt	87
4.5.3 Learners expecting more	88
4.5.4 Better understanding of concepts	88
4.5.5 Different expression of the concept	89
4.5.6 The impact of real life examples on concepts	89
4.6 Conclusion	90
Chapter 5: Discussion	91
5.1 Introduction	91
5.2 Comparison between pre-test and post-test	91
5.3 Perception (Intervention) of the study	97
5.4 Interview results	99
5.5 Additional aspects of the study	101
5.6 Discussion of the Results	102
5.7 Conclusion	103
Chapter 6: Summary and Conclusion	106
6.1 Introduction	106
6.2 Overview of the study	106
6.3 Major findings	110
6.4 Implications of this study	111
6.5 Limitations	112
6.6 Recommendations for future research	112
6.7 Conclusion	113
References	114
Appendices	128



## ABSTRACT

The purpose of this paper is to investigate whether the teaching of electric circuits in Grade 10 Physical Sciences using a conceptual change approach would enhance learners' understanding of the concept. The conceptual change approach is a process whereby concepts and relationships between concepts change over the course of an individual's lifetime. The process whereby conceptual change occurs is of central interest in helping to understand the process of learning, and is also important when considering the design of instruction. The study was conducted at a secondary school in a small town in the Karoo. Purposive sampling was used to select the sample of a Physical Science Grade 10 class. A mixed method approach was used to observe the effectiveness of the conceptual change approach - four conditions must exist before a conceptual change is likely to occur: (1) assess learners' dissatisfaction with their existing concepts; (2) the new concept must become intelligible; (3) the new concept must appear plausible; and (4) the new concept must be fruitful. All learners' total scores for the pre-test and post-test were calculated and recorded and total scores were statistically analyzed. This study could provide means to improve science teaching and learning. The learners were assisted to discover what was not clear to them, they were encouraged towards deeper understanding and to use their own knowledge to make sense of new concepts. The conceptual change approach could be used effectively by the teachers as it will assist to remove misconceptions learners have prior to the learning of new science concepts.

### KEY WORDS:

Conceptual change approach; Physical Sciences; Electricity; Electric circuits

# CHAPTER 1

---

## RATIONALE OF THE STUDY

---

### 1.1 Introduction

This section introduces a preliminary background to the context of the study. Other areas touched on are the value and relevance of the study, its aims and objectives, the problem statement and the research questions. A brief overview of the chapters of the thesis completes this section.

### 1.2 Background to the study

Physical Sciences prepare learners for future learning, specialist learning, occupation, citizenship, holistic development, socio-economic development and environmental management. Learners choosing Physical Sciences as a subject in Grades 10-12 (FET Band), including those with learning barriers, can have improved access to enrol for academic courses in Higher Education; professional career paths related to applied science courses and vocational career paths (DBE, 2011). Physical Sciences play an important role in the lives of all South Africans owing to their influence on scientific and technological development. It also plays a vital role in the country's economic growth and the social well-being of its people.

For the past five years, the matric results nationally proved to be disappointing. It is difficult for learners to understand scientific concepts across all ages and levels (Zacharia, 2007). The Physical Sciences results in the National Senior Certificate (NSC) examinations indicated that the subject is in serious trouble due to the drastic drop in the results of learners in questions relating to electric circuits. The National Senior Certificate Examination National Diagnostic Report (DBE, 2013) highlighted that learner achievement in this learning area proved to be poor, particularly in the Eastern Cape Province and especially when it comes to questions based on practical work. This report

also further indicated that one of the contributing factors when it comes to poor performance is electric circuits (Ohm's law). The above report is supported by the NCS Chief Markers Report (DBE, 2014) which highlighted the fact that the question that involves the application of Ohm's law (Question 8) was the question that was poorly answered in the Eastern Cape Province. Table 1 below reflects the results over the past five years.

**Table 1: RESULTS ANALYSIS OF PHYSICAL SCIENCE**

Matric Results Trend	2010	2011	2012	2013	2014
NATIONAL	47.8%	53,4%	61,3%	67,4%	61,5%
PROVINCIAL	43%	46%	53%	64,9%	51,5%
DISTRICT	49,5%	52,4%	60%	68%	77%
SCHOOL	27%	31%	32%	69,5%	33,3%

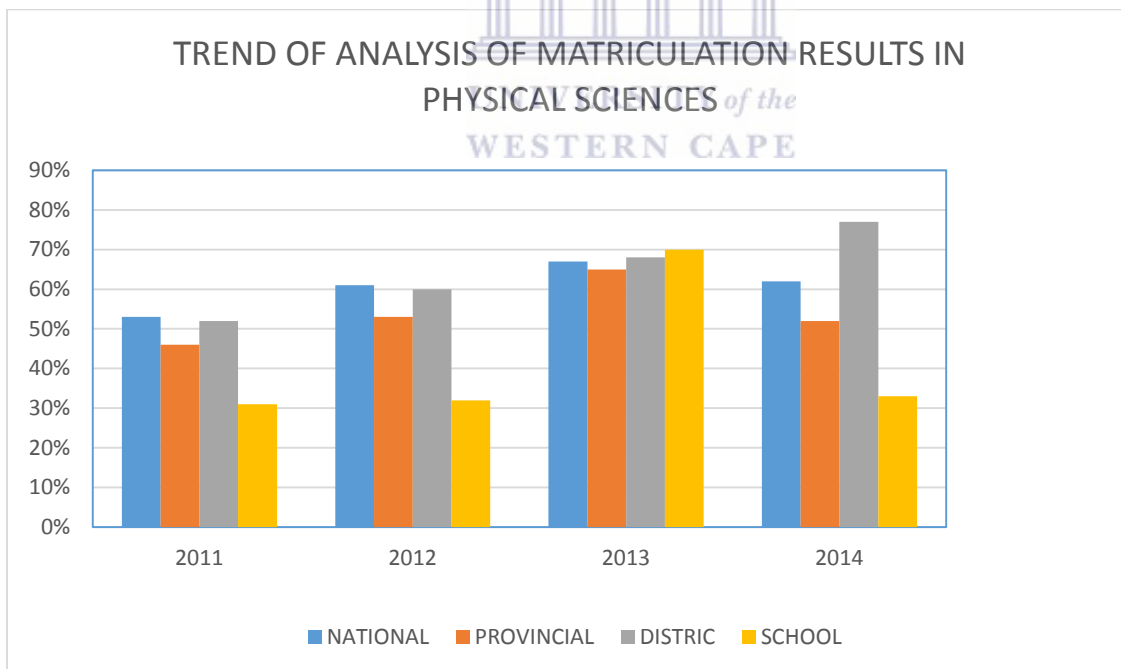

**Figure 1: Trend analysis of matriculation results in Physical Science.**

According to the Eastern Cape MEC for Education, Physical Sciences is one of the national gateway subjects that has improved by 4% in 2012 (DBE, 2012). There was also an increase in 2013 to 64%. Although the Eastern Cape Province's Physical Sciences results are at the bottom of the nine provinces, the various districts are working very hard to remedy the situation. One of the districts that is doing well is Cradock district. The district's Physical Sciences results are tabulated in Table 2 and Figure 2 below. The graph, showing the gradual improvement from 2008 up to 2014, is attached to the Appendices.

**Table 2: The Physical Sciences results of Cradock district**

<b>PHYSICAL SCIENCES: PASS PERCENTAGE HISTORY.</b>	
<b>YEAR</b>	<b>PERCENTAGES</b>
2008	54,3%
2009	43,0%
2010	49,5%
2011	52,4%
2012	60,0%
2013	68,0%
2014	77,7%

The percentages in Table 2 above clearly show the break and the beginning of the new curriculum in 2012 and the transition from one curriculum to the other. There was not much depreciation from the change of NCS to CAPS as it was stipulated below. Instead the graph showed a substantial improvement. This can be caused by different measures applied in this district which could not be displayed in the others. One factor that could have affected the results positively is the commitment of the District Subject Advisor and the involvement of dedicated educators. This commitment was illustrated by the results obtained by the learners in Physical Sciences at the end of 2014. The entire breakdown

of district results is shown in figure 3 where a detailed analysis of results was done. Figure 3 is included with the attachments in the Appendix A.

Certain topics that form part of the syllabus in Physical Sciences in grade 10 to 12 carry a greater weight than others. If these sections are not fully understood and the strategies and tools used are limiting, the situation can greatly contribute to a decline in performance. Therefore, the manner in which these topics are taught needs to be revised for improvement in learner understanding and performance. However, for learners to grasp the core of the content a well-designed curriculum is not the entire answer. The solution lies in fulfilling the need for working strategies to unpack such a curriculum whereby the work becomes easier to understand by breaking the contents up into smaller parts that can be examined separately.

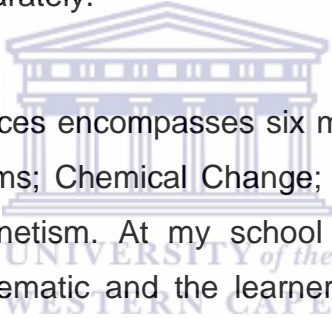

The syllabus for Physical Sciences encompasses six main areas of knowledge: Matter and Materials; Chemical Systems; Chemical Change; Mechanics; Waves, Sound and Light and Electricity and Magnetism. At my school the section on Electricity and Magnetism is particularly problematic and the learners find it difficult to understand. Ultimately grade 12 learners need to have a proper foundation from the lower grades up that might help with the improvement of their results.

In this study, the researcher will examine how effectively a conceptual change in approach can enhance Grade 10 learners' understanding of electric circuits. Should the project yield positive results, such results will be used as an indicator that this strategy could be used in a wider spectrum of the education sector.

As a Physical Sciences educator I have the experience of teaching the subject to grades 10-12 during the time of National Curriculum Statement (NCS) as well as the current Curriculum and Assessment Policy Statement (CAPS). The weighting of electricity and magnetism has changed from 12,5% in NCS to 8,75% in CAPS in grade 10. In my subject improvement plan for 2014 I have conducted a question-by-question analysis of the 2013

final examinations results. The analysis showed that the learners have difficulties in answering questions pertaining to electricity and magnetism. This study is an attempt to find teaching strategies that will address the challenges faced in electricity and magnetism to improve learner achievement in this knowledge area.

### **1.2.1 Context of the study**

This research took place in a community where people live below the poverty line in SA. In an overview of poverty and inequality in South Africa a poverty line is described by the division of the population into two groups on the basis of some measure that below the line a household/individual is considered to be poor, and above the line it is considered better-off. There are several reasons such as illiteracy; unemployment and lack of skills that makes most of the parents of learners at the research school live below the poverty line and therefore unable to assist their children with school work, particularly when it involves Physical Sciences. The study took place in a rural area where majority of people are unemployed and many depend on social grants. Some families are child-headed families where parents have passed on and there is no immediate family to assist the children.

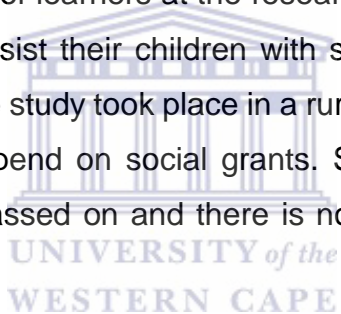

The researcher is an educator in Physical Sciences at a secondary school in the town of Cradock, Cradock District in the Eastern Cape Province. The school is situated at the centre of two townships housing the majority of the black and coloured communities. The school has an enrolment of 1 000 learners with 28 educators. We have two grade 10, one grade 11 and one grade 12 classes. There are only two qualified Physical Sciences educators and one unqualified educator in that field. The most educators at black high schools were at the time not qualified to teach science, with less than 20% having appropriate university diplomas. These educators generally lack science pedagogy and do not understand the nature of science and the scientific view of the world. Such educators would struggle with curriculum reforms which could lead to under-performance.



At my school we had less resources when compared to other neighbouring schools. While some of our equipment was either old or damaged or broken there was also no laboratory for us to conduct experiments. Classrooms were used to teach and for experiments we used the same classes in the afternoon. Our one advantage was that the District Office (for 27 schools) is located in the same town, making it easier and faster for us to get assistance from them when compared with the other schools.

The researcher focused on grade 10 learners for this research, the reason being that it is the entry grade in the Further Education and Training (FET) phase. Being equipped with a solid base in learning Physical Sciences at this level would influence their understanding as they proceed to higher classes. The electricity content remains relatively the same throughout the FET phase; the additional content is built on the base knowledge covered in grade 10.

The researcher has been teaching Physical Sciences for ten years. She started as an assistant teacher in the subject due to the shortage of qualified teachers for Physical Sciences. She was then sent for further training by the District Office and obtained a Bachelor Degree in Science. She was enrolled for ACE in Physical Sciences and then continued to a B. Ed (Hons). Currently, the researcher is pursuing a Master Degree in Physical Sciences (Science Education). The researcher is also a grade 12 marker of both paper 1 and 2 and involved in the District Matric Incubation classes and trainee workshops.

Chisholm and Chilisa (2012) point out that South African students score poorly in mathematics and science. South Africa is a country of extreme income inequality and poverty, and the impact thereof on mathematics and science education has not yet been examined. However, they point out that there are many poor countries, including our direct neighbors, achieving better performances in mathematics and science. That would be because none of them have such high levels of inequality, or a history in which the education of the majority of the people was so deliberate and violently hindered.

### 1.3 State of Education in South Africa

When it comes to international standard tests, South African learners perform dismally, although South Africa spends 20% of its budget on education, or 6,4% of the Growth Development Plan (GDP). This is considerably more than many other emerging market economies, yet we perform poorly when compared internationally. The statistics of the World Economic Forum's (WEFs) Competitiveness Index for 2012–2013 ranks South Africa's overall education system at 140 out of 144 countries, and its Mathematics and Physical Sciences education at 143 out of 144 (Education in South Africa, 2013).

The Minister of Basic Education denies the fact that there is a crisis in the education department. Statistics done in 2001 shows that there were 1,2 million children who enrolled in grade 1 but only 44% stayed in the system to take their National Senior Certificate (NSC) in 2012 (Education in South Africa, 2013). Only 12% of that grade 1 cohort ended up passing their NSC well enough to study for a university degree; only 11% passed Mathematics and Physical Sciences with a mark of 40% or above (Education in South Africa, 2013).

Why, then, is South Africa not reaping what it spends? Three critical factors influencing educational outcomes can be highlighted: educators, management of educators and outside disruptions to schooling (such as learners falling pregnant) (Education in South Africa, 2013). However, there were different cases that were picked up such as in-classroom factors pertaining to teaching and resources; in-school factors such as leadership and management and out-of-school factors such as parental involvement and socio-economic circumstances (Education in South Africa, 2013).

Educators bear the criticism for South Africa's declining education standards, and content knowledge of educators is a serious challenge. An opinion often aired is that education is only as good as your educators, and that universities are failing to produce quality

educators, particularly in Mathematics and Science. Educators might show patchy content knowledge; in some cases, it was found that they only teach those parts of the curriculum that they are comfortable with. A professional attitude needs to be introduced to young people entering the teaching profession. For many persons it is a case of protected employment, as they fail to meet deadlines and deliver quality lessons – in many cases they are not being supervised to make sure they are doing a good job.

One solution that was introduced to schools was education inspectors. This raised anger in some education unions who opposed the change. This reaction draws attention back to a time when inspectors from the old government were viewed with suspicion in black schools. The education inspectors were viewed as just there to find fault and to police educators without playing any developmental role. However, the education system can not only fail only due to the presence or absence of education inspectors; the school management also plays a vital part in the setup. There are two factors crucial in education: educators and management. A well-run school will almost invariably have a good principal. School management, which largely depends on principals, is one of the in-school factors.

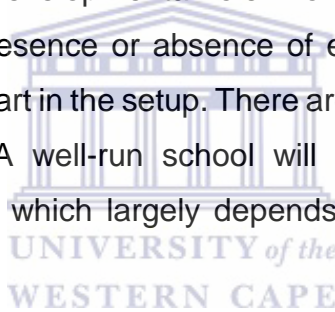

Education district offices, which fall under provincial education departments, are supposed to support and monitor schools, both in administration and subject areas. However, the districts offices are often understaffed and their personnel may not have the right skills. The districts cannot visit and support schools often or effectively enough to ensure good quality education. Without well-functioning district support and monitoring, a school's success often comes down to its principal. School governing bodies (SGBs) hire principals subject to the approval of the provincial heads of department (Education in South Africa, 2013). A well-run school is therefore likely to have a well-functioning SGB. SGBs include teachers and pupils, but a majority of their members must be parents.

However, about two-thirds of South African children do not live in the same household as their biological parents (DBE, 2013). In our communities we often miss the parents.

Furthermore, poverty and adult illiteracy often prevent parents who are indeed present from getting more involved in their children's education. Parents play a cardinal role, but they often don't have the knowledge of how to help their children.

There are other out-of-school factors of constraint such as poverty and the attitude of parents and society towards education. Socio-economic factors come down through generations and steadily affect educational outcomes for children. Some children cannot afford higher education because they do not have enough money for fees. Family commitments, having to work at homes, and pregnancy account for another of those not receiving instruction. Noteworthy is the fact that only few children are not in education because they consider it useless. Many bright young people are missing out on the chance of getting a higher education because they cannot afford it. There are not enough bursaries for the number of students now coming out of the school system, even if pupils unqualified to study for higher education are excluded.

Access to education has improved dramatically over the last few decades. The number of black candidates who take the exam every year is increasing gradually but steadily. Yet this improved access has brought with it the challenge of educating a fast-expanding school population using educators who were often themselves the product of the apartheid-era Bantu (Black) education (Education in South Africa, 2013). In criticizing education policy in South Africa, people often forget the challenges that were faced after 1994. The transition period involved a difficult process of merging all the old education departments, equalizing expenditure and distributing educators. On the whole different policies were introduced to handle that process. The post-apartheid policies have been part of the problem, in particular the frequent changing of the curriculum.

The most serious compromises were made in this transition period, particularly in giving the provinces more power over education. The desire after the apartheid era was to disperse power over government functions, such as education, but this can make it very difficult for a national department to ensure that its policies are implemented effectively.

The failures in South Africa's education system reveal the problems that have affected governance in the country more generally since 1994. A lack of skills, monitoring and accountability has led to poor policy implementation, inferior training of educators and bureaucrats and a system many people have lost hope in. Those who can afford to are increasingly sending their children to private schools (Education in South Africa, 2013).

## **1.4 Interventions in Science Education in the Eastern Cape Province**

### **Provincial**

The Eastern Cape Education Department is struggling to fill vacant teaching posts in some of the province's most understaffed schools. Most educators are temporary employed. Some of these educators are gradually issued with letters of employment and there are over 500 temporary educators in 10 of the province's districts. These educators are qualified and registered with the South African Council of Educators. This is a provisional measure to ensure that all schools have teachers while the process of finalizing permanent post-provisioning continues. The post-provisioning process would involve moving teachers from overstaffed schools to schools where their services are urgently required. This process of re-deployment will affect all educators at schools with a low learner enrolment, with the Department issuing a valid recruitment bulletin that would result in permanent employment into vacancies. This intervention will assist the Education Department to ensure that the majority of teaching posts are permanent and that all teachers' services are optimally utilized. This is essential for finally ensuring lasting steadiness in education in the Eastern Cape.

The frequency of teachers moving from rural to urban or the so called "best resourced schools" will soon be a thing of the past. The Accelerated School Infrastructure Development Initiative (ASIDI), which seeks to eliminate schools built using inappropriate materials throughout the country is as a result of new state-of-the-art teaching institutions being delivered. A total sum of R18, 2 million was spent to build the new schools. To date 116 completed ASIDI schools were delivered to various communities across the country:

87 in the Eastern Cape, 15 in the Western Cape, 6 in the Free State, 4 in Mpumalanga, 2 in Limpopo and 1 in the Northern Cape.

An important mandate of the programme is the delivery of basic services to schools that previously had none. Over and above the 116 schools completed, the ASIDI project has also provided 499 schools with water, 425 with sanitation and 289 with electricity. The new school offers facilities such as a computer lab, 7 classrooms, a staff room, principal's offices, a multimedia centre, a physical science laboratory, a kitchen, Grade R-centre and decent sanitation. ASIDI is helping to restore dignity to rural education and a sense of pride to communities. The new school offers teaching in an environment that is conducive to learning. Educators are excited about this intervention and report that learner enrolment has increased rapidly, especially in the case of those who chose to study Mathematics and Physical Sciences. The new schools have the following material: furniture, desks, chairs, interactive boards and tables; attendance is 100% as learners are motivated to come to school every day. The issue of Information Communication Technology (ICT) has been taken into consideration and the provision of 50 tablets to the school made learning and teaching even more exciting - this was reported by an educator from the school that was rebuilt. They added to this by stating that leaving the ASIDI schools for urban schools would no longer be a consideration. The new schools have high quality resources that are also in line with the demand of the world of technology.

### **District and School**

Grade 11 learners who failed the phase more than twice were taken to the next grade. This put pressure on the district officials, principals and educators because that would have a negative impact on the results of schools and the district as a whole. The District Office would have to come up with a plan on how to assist these learners to catch up with the work in the next grade. The district intervention to maintain and assist the learners' results was as follows: -

There will be incubation classes during Saturdays where learners would do revision and revise previous examination papers. The learners are doing both Mathematics and Physical Sciences and four hours for both subjects were allocated. Winter and Spring Schools were organized during the holidays to do catch up with grade 11 work and do revision of recent and previous question papers. Learners attended for two weeks in June and a week during each of the March and September holidays. Focus was on the critical subjects, and afternoon classes were also arranged. Telematics was arranged to assist and enable the learners to interact with a facilitator. These classes were organized to take place twice a week. Telematics takes an hour and the critical subjects are treated in different times. Each subject has an hour and two hours are allocated per day. The entire intervention was an initiative of the District Office and they carried all costs involved. The district is made up of 10 schools and there are 114 learners who are doing Mathematics and Physical Science.

### **Interventions in Eastern Cape.**

The Department of Education, Eastern Cape Province in conjunction with the University of the Western Cape initiated a project whereby teachers from the various districts were selected and trained in Advanced Certificate in Education, specializing in Physical Sciences. In this project, teachers were exposed to various methodologies as to how to teach Physical Sciences in order to improve learner performance, and also to motivate and encourage learners to take Physical Sciences as a specialization subject in secondary school as well as at tertiary institutions. The project continued and trained these teachers up to a Masters level. The teachers are utilized by the Eastern Cape Education Department to train other teachers in fields like Natural Sciences in the General Education and Training (GET) phase.

The Eastern Cape department of Education has programmes planned to assist the power performing school and progressed learners. Learner Attainment Improvement Strategy (LAIS) programs that are in place as a form of alleviating challenges in physical sciences include:



1. Incubation classes which take a few learners from a large pool of learners and only cater for bright sparks whereas most learners are those who are struggling with physical sciences.
2. Winter and spring schools which are marked by overcrowded classes and do not cater for individual attention for learners.
3. Mini quizzes and Astro quizzes competitions that take place in March and take only two learners per school.
4. Science Festival (Scifest Africa) which is held in Grahamstown but not all learners are able to attend the festival as it is far from many schools in the province.
5. NMMU program for FET physical science educators which aims at developing educators in physical sciences.
6. Science Olympiads, SAASTA science school's debates and Science Week target only a few learners and other schools do not bother participating.
7. 1 + 4 program which is aimed at developing foundation phase educators in numeracy which is a base for physical sciences.
8. Maths, Science and Technology grant which is aimed at supporting schools that are struggling with physical sciences.

## **1.5 Research Problem**

According to Hewson, students learn things they didn't know by making connections between what they already know; this is not a problem when their present views can be reconciled with what they learn. Another way to think about this is to regard existing knowledge as "capturing" new knowledge (Hewson, 1981). Conceptual change involves the alternation of conceptions that are in some way central and organizing in thought and learning. Most cases of altered belief do not fall into this category. The process whereby conceptual change occurs is of central interest in helping us to understand the process of learning, and is also of considerable importance when considering the design of instruction. As learners are introduced to the theory of Ohms Law and other related topics, they have to collect all the information and make sense of what they have learnt. They



have to make sense at their own level of understanding so that they could presume what electric circuit is all about. To achieve my goal, my study will be based on how effective the conceptual change teaching approach is in enhancing learners' understanding of electric circuits.

## **1.6 Research questions**

In the light of the above problem statement, the research questions for this study are formulated as follows:

**How effective was the conceptual change approach in improving learners' understanding of electric circuits?**

- (i) What was the learners' initial understanding of electrical circuits?**
- (ii) How was the conceptual change approach used to teach electric circuits?**
- (iii) What was learners' understanding of electric circuits after the conceptual change lessons?**
- (iv) What were learners' perceptions of the conceptual change approach to teaching?**

The aim of this study is to improve learners understanding of electric concepts and to develop the ability to link what they will learn in class with the outside world. The study will highlight a number of issues that lead to poor academic achievements in Physical Sciences. This study will also provide the learning strategy in Physical Sciences for learners to improve their learning process of simple electric circuits.

## **1.7 Significance of the study**

The value of this study will be to provide learners with a better understanding and more knowledge on electricity and electric circuits. They will be assisted in discovering that which was not clear to them and they will be enabled to come up with their own

understanding. It will also promote meaningful learning as they will use their own knowledge and make sense out of it. Conceptual change as a teaching strategy can serve to improve the teaching of science concepts and in this study, possibly improve learners' understanding of Ohm's law. It could provide teachers with a vehicle on how to use conceptual change approach to teach learners that which they previously found difficult to comprehend.

## **1.8 Limitations of the study**

Limitations of the study were that the class that have been purposefully selected for this study does not represent the whole population of Grade 10 Physical Sciences classes in Cradock district, nor the province or country. Therefore, the findings cannot be directly generalized to the larger population.

## **1.9 Structure of the thesis**

This study is outlined in the following way: -

Chapter 1: Introduction – the motivation of the study to be undertaken, problem statement outlined, aim of the study, research objectives, research question were outlined in this chapter.

Chapter 2: Literature Review – reviews the research literature on the learning and teaching of electric circuits. Some studies which have shown learners confusion in this area and other signifying methods of teaching to improve understanding are also revised.

Chapter 3: Methodology – an outlines research strategy and a detailed explanation of methods and instruments used to implement the studies undertaken in this study.

Chapter 4: Findings – denotes the results of this research study.

Chapter 5: Discussion – present discussion of the findings when these are analysed collectively.

Chapter 6: Conclusion – provides summary of the study, conclusion and recommendations that emanated from this research study

## 1.10 Conclusion

The orientated introduction given above attempted to provide a transitory introduction to this study. It outlined the statement of the problem and motivation for conducting the research study. The literature is reviewed for the purpose of finding more information about the topic under investigation. The information obtained from the literature review enables the researcher to achieve the aims and objectives of the research study. The theoretical framework informing the research study was discussed. The research question serves as a guiding path for the entire investigative journey. The research methodology chosen combined methods on which the research was based. The ethical aspects are embedded in the participants' consent forms which are attached on the appendix. The final chapter division in this study evidently validates the study layout.

The next chapter focuses on the literature review regarding the Conceptual Change teaching approach.

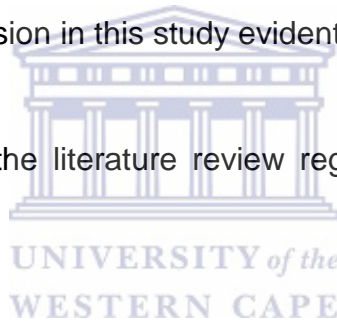

## CHAPTER 2

---

### LITERATURE REVIEW

---

#### 2.1. INTRODUCTION

In the previous chapter the problem statement, context, rationale of the study and the research questions that directed the study were outlined. This chapter outlines the theoretical framework and literature review on teaching electric circuits using a conceptual change approach. It offers the theoretical layout for understanding of the research problem and research aim stated in chapter one.

#### 2.2 Definitions of terms



A.S.	Assessment Standard
CAPS .	Curriculum and Assessment Policy Statement
CCA	Conceptual Change Approach
DBE	Department Of Basic Education
DoE	Department Of Education
ECDoE	Eastern Cape Department of Education
FET	Further Education and Training
GET	General Education and Training
L.O.	Learning outcome
NCS	National Curriculum Statement
OBE	Outcome-based education
SMT	School Management Team

#### 2.3 Research question

**How effective was the conceptual change approach in improving learners' understanding of electric circuits?**

- (i) **What was the learners' initial understanding of electrical circuits?**
- (ii) **How was the conceptual change approach used to teach electric circuits?**
- (iii) **What was learners' understanding of electric circuits after the conceptual change lessons?**
- (iv) **What were learners' perceptions of the conceptual change approach to teaching?**

The study aimed to contribute to improving the learner's understanding of electric concepts and to develop the ability of connecting theory and class work with the outside/real world, thereby providing a learning strategy in Physical Sciences for learners to develop a different learning process of simple electric circuits (Duit, 2009).

## **2.4 Theoretical framework for the study**

This study is underpinned by the theories of Constructivism and Conceptual Change Approach.



The word "concept" can be defined as "referring to the common characteristics of similar or sometimes even different objects and events with one word, or one term." On the other hand, in a broad sense, "concept" is information structure that represents the changeable common characteristics of different objects and phenomena, it is a given meaning in our minds, and it can be expressed with one word, and is shaped as a result of people's views.

### **2.4.1 Constructivism**

According to Constructivist Theory, the learning process indicates the way in which individuals construct new ideas or concepts based on prior knowledge or experiences (İpek and Çalik, 2007). They alluded that it is imperative that learners will always bring

prior personally constructed knowledge and beliefs with them - knowledge that could either be relevant or not to the scientific concepts.

Therefore, constructivism did not divorce itself from *social* constructivism theory which strongly suggests the importance for learning of the social context and interaction with others. On the other hand, the cognitive learning theory attests that learners should take the leading role in their learning, find knowledge for themselves and test the formulated hypotheses (Schunk, 2000). These theoretical views on learning seemed to be in accordance with the kind of learner envisaged by the National Curriculum Statement (DoE, 2003), which place emphasis on self-discovery, collaborative learning and interdependence between learners and teachers in the learning process. The interpretation of student responses as driven by alternative conceptions suggests that learning may involve changing a person's conceptions in addition to adding new knowledge to what is already there. Constructivist research on conceptual change in Science Education, has been of an applied research type from the very start in the early 1980s.

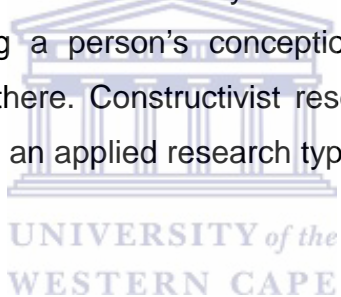

It is important to use as it will help identify the learner's existing concepts. Constructivism is a theory of learning in which every learner constructs his or her ideas (Önder, 2006). It stresses that each individual must construct meaning for himself or herself (Rasmussen, 1998). Thus, constructivism is a theory of learning in which every learner constructs his or her own ideas.

Bodner (1986) states that knowledge is constructed in the mind of the learner, therefore, the fundamental assumption of constructivism is that the student must recognize his or her own conceptions, analyse them and decide if they need reconstruction. If the learner decides his or her conceptions require reconstruction, then she/he will restructure these conceptions so that the new conceptions will be suitable to scientific explanations. Therefore, it is necessary to connect new information with already existing knowledge, experiences.

In constructivism, learning is defined as the active construction of meaning and it involves a change in the learner's conceptions (Kingir, 2011). Kingir further argues that learners are not viewed as passive recipients of knowledge; rather they are seen as responsible for their own learning. Joseph, (2011) concurred that constructivists have firm convictions regarding the process of learning and context in which the learning takes place. Önder, (2006) believes that there is a real world that learners experience, but that meaning is imposed by the learners rather than existing in the world independently of them. They also believe that there are many ways to structure the world and there are many meanings or perspectives for any event or concept (Duffy & Jonassen, 1991). For conceptual understanding to take place a subject such as chemistry, learners need to experience different forms of representation of a concept (Joseph, 2011).

When learners want to understand new material, they must use the new knowledge and combine it with their existing knowledge (Bergquist & Heikkinen, 1990). The main function of constructivism is to organise knowledge by using previous experiences or understandings. Past experiences formed from observing certain processes in the world are important for learners, because they supply the learner with the ability to make estimates and to supply reasons for these predictions. When a prediction is made and the learner's past experiences provide an incorrect prediction, the learner must be placed in a cognitive conflict, in a situation where he or she is able to compare the cognitive universe with the natural universe. In other words, the learner must be placed in a "cognitive conflict".

Cognitive conflict plays an important role in conceptual change, when providing an assimilation and accommodation framework (Treagust & Duit, 2008). Therefore, cognitive conflict plays an important role in learning science. Treagust and Duit (2008) concluded that conceptual change is positively influenced when cognitive conflict strategies are used. These strategies involve creating situations where learners' existing conceptions about particular topics are made explicit and then directly challenged in order to create a state of disequilibrium. Cognitive conflict strategies are aligned with Posner's theory of

conceptual change. That is, learners must become dissatisfied with their current conceptions and this is the first step for the conceptual change model. By recognizing the inadequacy of their conceptions, learners become more open to changing them.

Selley (1999) also stresses that construction is an internal, personal and often unconscious process. It consists largely of reinterpreting pieces of knowledge that have been obtained from the student experiences and interaction with other people and to build a satisfactory and comprehensible picture of the world. Moreover, constructivism is a “meaning making theory” where individuals create their own new understandings based on the interaction of what they already know (Richardson, 1997; von Glasersfeld, 1995).

Therefore, every individual constructs his or her own realities based on existing knowledge and thus it is not meaningful to talk of the objective truth. For example, when educators believe they have been understood by their learners they should not put themselves into believing that they share the same opinions as their peers. No one can ever be sure of this, because understanding is also a personal construction of things: you may understand in one way but you may be understood quite differently by someone else (Rasmussen, 1998).

Constructivist approach is learner-centred. Learners should be active participants in the learning process since every learner will construct his or her individual meaning. Therefore, the instructional activities must be attractive to the learner and inspire active participation. Active participation in a constructivist manner means that the learners are actively testing the new concepts in order to comprehend whether the new concepts can be explained by existing or prior knowledge. Then they can evaluate how well the new concept is explained by the existing diagram and they can choose whether to modify or change current schema. Therefore, constructivism is a theory of learning that rejects the idea that it is possible to transfer the content of teaching to pupils (Rasmussen, 1998); it states that knowledge is present in the individual and that knowledge cannot be transferred completely without any change from the educators’ head to that of learners.



Constructivist teaching requires the educator to act as a facilitator and create constructivist learning understandings. That is, the educator no longer educates by obligation, but by negotiation. It involves more learner-centred, active learning experiences, more learner-learner and learner-educator interaction, and more work with concrete materials in solving realistic problems (Shuell, 1996).

The Constructivist classroom supports inquiry and learners can direct their ideas and feelings freely. Constructivist approach on the other hand, “places emphasis on the meaning and significance of what the students learns, and his/ her active participation in constructing this meaning” (Selley, 1999). Moreover, constructivist learning environments are designed to satisfy seven pedagogical goals (Honebein, 1996). These are:-

1. Provide experience with the knowledge construction process: learners take primary responsibility in selecting topics and methods of how to learn.
2. Provide experience in and appreciation for multiple perspectives: learners must engage in activities which enable them to think about several ways to find solutions since the real life problems rarely have one correct solution.
3. Embed learning in realistic and relevant context: learning activities are designed so that they reflect all the complexity that surrounds them outside the classroom.
4. Encourage ownership and voice in the learning process: illustrates the learner centeredness of constructivist learning.
5. Embed learning in social experience: learning should reflect collaboration between learner and teacher and learner and learner.
6. Encourage the use of multiple modes of representation: a variety of activities and instructional strategies coupled with variety of different media provides richer experiences.
7. Encourage self-awareness of the knowledge construction process: it is important for learners to know how they know.

If teaching methods are based on constructivism, it is a helpful way to help learners' learning; it also helps teachers applying constructivism in their science classrooms to promote meaningful learning (Wing-Mui, 2002).

As noted by Wing-Miu (2002), though we need to limit the cognitive perspective when teaching from a constructivist's view, we should still keep in mind the following points when teaching concept:

- acknowledge the learner's existing knowledge;
- teach fewer concepts at a time;
- improve abilities within key areas of progression inside concept development, since learners are exposed to scientific concepts at a very young age; and
- acknowledge the diversity of learners.

#### **2.4.2 A Comparison of Traditional and Constructivist Approaches**

Constructivist teaching focuses on learners learning as opposed to a focus on completing the curriculum (Mintzes, Wandersee, & Novak, 1998). The traditional view regards learning as a process of transmitting the knowledge (Önder, 2006). However, in constructivism learning is considered to be a process where the learner is actively engaged in constructing knowledge whilst interacting with the environment and society (Richardson, 1997). In a traditional view the mind is considered as if it is a blank slate, waiting to be written on or filled. On the contrary, constructivism takes into account the prior ideas (Rumelhart, 1980; Mintzes, Wandersee, & Novak, 1998).

The traditional teacher is responsible for effectiveness in extending knowledge and learning (Önder, 2006). Moreover, information should be presented to the pupil in a clear, systematic and stimulating way (Selley, 1999). However, constructivist teachers must find ways to understand their students' viewpoints and their alternative conceptions and develop classroom tasks which help knowledge construction while performing all that tasks expected of the teacher playing the role of facilitator (Selley, 1999).

In traditional perspective successful teaching leads to growth of learners' stock of knowledge and understanding which leads improvement in academic performance (Önder, 2006). On the other hand, from constructivist perspective successful teaching leads to growth of understanding, breadth of vision and maturation (Selley, 1999). The

traditional view assumes that there exists a knowable reality outside of human perceptions. However, constructivist view acknowledges that there exists an external reality and realizes that cognizing beings can never know what that reality is actually like (Tobin & Tippins, 1993).

It is important to realize that, although the teacher supports all the items mentioned above and provides a rich learning environment, one should not forget that each learner in the class will perceive the environment in a different way. Therefore, in order to understand learning in a constructivist classroom context, it is important to consider each learner's interactions with the environment and how those interactions affect the learning process.

#### **2.4.3 Types of Constructivism**

The literature identifies different types of constructivism, but for this study the focus is on Social Constructivism. Steffe and Gale (1995) focus on two different types of constructivism, namely radical constructivism and social constructivism; while Ishii (2003) states that the term constructivism describes about fifteen different types of constructivism. This includes adding the following adjectives to the word constructivism – contextual, dialectical, empirical, humanistic, information-processing, methodological, moderate, Piagetian, post-epistemological, pragmatic, radical, realist, social and socio-historical.

Raskin (2002) and Julie *et al.* (1993) describe information-processing constructivism as knowledge which is not passively received but actively built up by the cognizing subject and the rejection of an epistemologically skeptical principle. Information-processing constructivism acknowledges that the learner is busy with active processes, both individual and personal, and that everything is based on the learner's previous knowledge. From the results of many thousands of studies reported in Duit (2009), research has shown that individuals are not simply passive learners but make sense of new information in terms of their previous ideas and experiences.

Julie *et al.* (1993) describes radical constructivism as constructivism that is based on both the principles mentioned in information-processing constructivism and they elaborate: “The function of cognition is adaption and serves the organization of the experimental world, not the discovery of ontological reality.” Ishii (2003) further explains radical constructivism as the individual’s knowledge being in a continuous state of re-evaluation. From this perspective we can say that the individual’s knowledge is continuously being adapted and evolved. This constructivism can be seen as the ability to use cognitive structure to adapt to the situation and ultimately to survive.

#### **2.4.4 Social Constructivism**

Social Constructivism, as one of the types of constructivism, is more suited to this study because of its focus on learning as a social process. Learning and development in learners are shaped through social interaction, cultural tools and activities (Woolfolk, 2010). This is accomplished when learners interact with one another around an activity. Many scientists are of the view that higher mental processes develop through negotiation and interaction (Woolfolk, 2010). Kundi and Nawaz (2010), noted that social constructivism is a collective learning process that receives information from the community, peers and parents.

Caine and Caine (1994) mention that learners’ brains are shaped by their environments. When a child is born it grows up in a family, shaping its brain through experiences and modelling of family members. As the child grows up its social circle expands to more than the immediate family and this leads to more experience and modelling (Rogers & Horrocks, 2010). The child’s initial learning experience forms the basis of future learning. Educators need to be aware of social influences on the learners and manage the classroom environment so as to ensure maximum safety and participation.

Vygotsky (1978) was the pioneer of social constructivism. His theory focused on the relationship between the individual and society as well as the influence of social interaction, language and culture in learning. He developed two theories namely, Zone of Proximal Development (ZPD) and the More Knowledgeable Other (MKO). According to

him, learning is a continuous movement from the present intellectual level to the higher potential level. Every function in the child's learning appears first, on the social level and later on the individual level. This applies the same as voluntary attention, logical memory and the creation of concepts.

Zone of Proximal Development is the distance between actual developmental level as determined through problem solving under adult guidance or in collaboration with more capable peers (Vygotsky, 1978). His view is that once a learner is within the ZPD for a particular task and provided with assistance, will assist the learner to do a task and once the learner masters the task, assistance can be removed and the learner will be able to complete the task without assistance. The MKO is the person who is more knowledgeable than the learner on the relevant subject matter. Within the context of this study, the Physical Science teacher is considered the MKO who will facilitate learning at the three levels of electricity and electric circuits.

Kim (2001), Robottom (2004) and Treagust and Duit (2008) state that the focus of social constructivism is mainly on culture and context within society and that knowledge is constructed using the understanding gained through society. The underlying metaphor here is perceived as conversation, where the individual uses language to form meaningful structures. Social constructivism is based on certain assumptions reality cannot be discovered: Knowledge is also constructed within the social context where individuals create a sense of meaning by interacting with one another. Learning is viewed as a social process and meaningful learning occurs when individuals are busy with social activities.

In constructivism, every learning process includes a search for similarities between what is already known and the new and unfamiliar one (Önder, 2006). New concepts are tried to be explained by concepts that students already have and it is done by establishing relationships between them. Therefore, the learning process often requires major restructuring of students' already existing conceptions. In social constructivism there are two aspects that affect learning (Kim, 2001). One of the aspects comprises the symbol (language and logic) and mathematical systems that the learner obtains throughout his

life; the second aspect is the nature of interaction in society. Not everyone knows everything; therefore, we need to interact socially with other knowledgeable people. From them we acquire the knowledge to use efficiently in order to promote meaningful learning.

Learners arrive at the science class with their own ideas, beliefs and understanding of how things work. Therefore, learning does not take place when the teacher fills the learner's heads with information and data, but when their existing ideas and beliefs are worked on and changed. Learning is seen by Robottom (2004) as conceptual change, constructing and reconstructing concepts and this includes existing concepts. Constructivism is therefore a major theory when working with conceptual change; and constructivism, whether radical and/or social influences the way in which conceptual change research is conducted (Treagust & Duit, 2008).

According to Julie *et al.* (1993) the following are the most important aspects of a constructivist approach:

- assists learners when working with new methods in the learning process;
- helps learners to expand their knowledge of the subject or topic; and
- helps learners to develop instructional methods to promote meaningful learning and scientifically acceptable concepts – to create a sense of enthusiasm to learn and to be active within their own learning.

These aspects can also be applied to the role of the teacher. When we use constructivism in mathematical or scientific situations, we say that there are only true facts, principles, theorems and laws, as described by Ishii (2003). This is how knowledge is perceived in science. To clarify this statement, we can use Newton's gravitational law as an example – "Every point mass in the universe attracts every other point mass with a force that is directly proportional to the product of their masses and inversely proportional to the square of the distance between them" – there is only one way this law is defined and that is the correct way.

Wing-Mui (2002) states that when emphasis is placed on a constructivist instruction process, it increases the realm of certain areas in a science classroom. These areas include the learner's conceptual knowledge, active engagement with scientific content and application of the knowledge gained to real-world situations (Wing-Mui, 2002).

Based on the scrutiny of the constructivist theories, the researcher agrees with Kesamang (2002) and Mpofu (2006) that the curriculum developer, the science teacher as well as the author of science textbooks should be aware of the fact that the learners' socio-cultural background may obstruct the easiness with which they learn school science. Therefore, efforts should be made to discover those elements of the learners' culture that are inconsistent with the scientific culture and which could impact negatively on their achievement in school science.

## **2.5 Conceptual change theory**

In physics concepts mean a great deal, with misconceptions obstructing the formulation of the acquired knowledge. To avoid that and for meaningful learning, we need to revise the old information and replace the wrong one with the right one, like in the "Conceptual Change Process." (Smith, Blakeslee & Anderson, 1993).

In general, it can be said that pre-instructional knowledge formulation has its origin in the following resources: (1) experiences and perceptions that extend as far back as early infancy, (2) a wide variety of cultural values and ideas, and (3) language factors (Ruhf, 2003). Conceptual change approach is the process whereby concepts and relationship between them change over the course of an individual person's lifetime. They possess a knowledge pool that at any given moment result in direct experience with his/her life-world. These could be the empirical, physical world as well as his interaction with his parents, teachers, other adults, the mass media, and siblings during formal, informal and non-formal situations (Jordaan, 1992).



Conceptual change texts present new theories to disprove the old ones. When the researches on teaching physics have been observed, we have found many studies on the effectiveness of conceptual change texts (She, 2003; Başer, 2006; Başer and Geban, 2007; Karakuyu and Tuysuz, 2011). In some of the researches the effectiveness of conceptual change texts has been researched with a different method (Hırca, 2011).

Chi, Slotta, & De Leeuw (1994) defined conceptual change as learning to see when certain existing concepts change. Learners have an active role in a learning process - they construct their own knowledge through their existing ideas, understanding or experiences. In this process they create their own personal meanings by using their ideas. Hence, it is possible for them to misinterpret the new concepts and to construct misconceptions by using their existing knowledge and experiences. In order to minimize (if not to eliminate) these misconceptions, educators need to consider conceptual change approach activities. Ausubel (1968) stresses the importance of existing knowledge in the process of acknowledging new concepts.

Conceptual change theory assists the learner in changing his/her existing concepts. When the old knowledge does not match scientific concepts; i.e. when they develop misconceptions, they cannot learn well. Conceptual change is defined as a process of learning science in a meaningful way that requires the learner to rearrange or replace existing misconceptions in order to accommodate new ideas (Smith et al., 1993). In other words, the term “conceptual change” is used to describe the kind of learning required when the new information to be learned comes into clash with the learners’ prior knowledge acquired on the basis of everyday experiences. This situation requires prior knowledge to be reorganized.

The “Conceptual Change Approach” that was initiated by Posner et al (1982) is fundamentally based on four conditions. First of all, the learner must be aware that the old concept she/he knows is inadequate (dissatisfaction). Learners must become dissatisfied with their existing conceptions. When the discrepant event is presented, there



must be dissatisfaction with the existing conception. Secondly, the new concept must be understandable (intelligibility). Learners must achieve a minimal initial understanding of the scientific conceptions; they are not going to adopt a new conception unless they can first represent it to themselves – therefore they must find it intelligible. In the third place the new concept must make sense to the learner (plausibility). It must be connected to the current cognitive framework of the concept and related ideas and it must be believable. Finally, the new concept must be beneficial to learners (fruitfulness) meaning that they should in future be able to solve similar problems relating to the new concept. Learners must see that the scientific conception is useful in order to understand other examples of phenomena. A new concept should suggest the possibility of the fruitfulness of the research program. Figure 2 below shows the different cognitive processes involved in conceptual change theory.

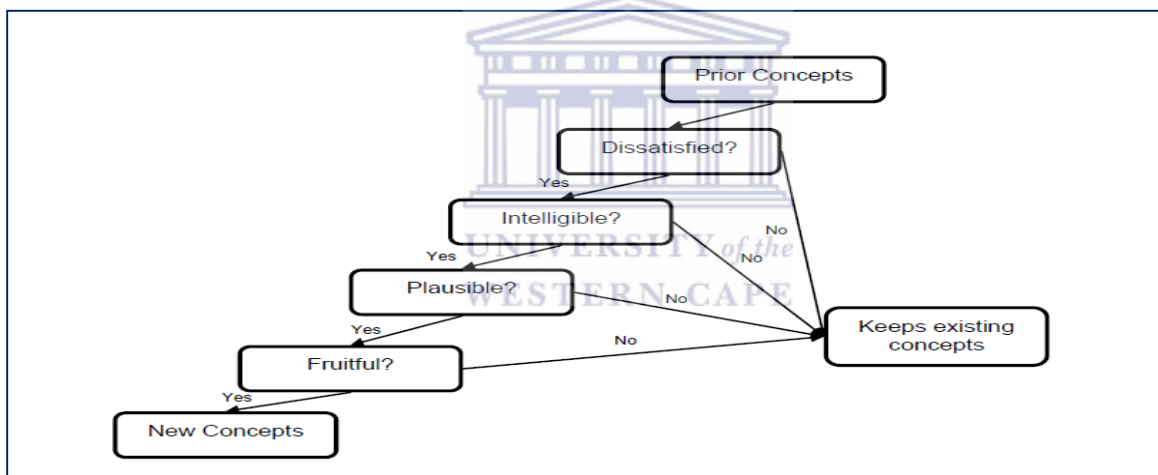

Figure 2. Cognitive process available within conceptual change (Adapted from Read, George, King, & Masters, 2006)

Treagust and Duit (2008) gave the following advice: an intelligible concept is one that is understood by the learner and it is non-contradictory. A plausible concept is one that the learner believes in addition to the existing knowledge. A concept is seen as fruitful when it is used to solve a number of problems and not just one. It is also seen as fruitful when new research directions can be created. This is the way conceptual change is perceived and the order in which a concept needs to travel.

Conceptual change (Treagust & Duit, 2008) can be placed into different sub-categories – epistemological, ontological and affective orientation. In the epistemological view the focus of the study is placed on the learning of science concepts. Epistemological perspective is the classic way in which conceptual change was seen for many years. Appropriate analogies help students make connections between familiar knowledge and new science concepts (Treagust & Duit, 2008). Consequently, analogical-based instruction can produce interest as well as cognitive gains as measured by a conceptual change approach. Research has shown that analogical teaching approaches can enhance student learning although analogies for teaching and learning can be friend or foe - depending on the approach taken by the teacher (Harrison & Treagust, 2006).

Other studies on conceptual change emphasize the importance of the role of the learner, suggesting that the learner can play an active and intentional role in the process of the restructuring of knowledge (Sinatra & Pintrich, 2003). An important aspect of conceptual change is a learner's conceptual status (Treagust & Duit, 2008). They further argued that, when dissatisfaction between competing conceptions reveals their incompatibility, the new conception may be assimilated alongside the old. Two things might happen: if the new conception achieves higher status than the prior conception, conceptual exchange may occur. If the old conception retains a higher status, the method of conceptual exchange will not proceed for the time being. It should be remembered that a replaced conception is not forgotten and the learner may wholly or partly reinstate it at a later stage because the learner, not the teacher, makes the decision about the status of the new concept and any other conceptual changes.

Learning for conceptual change is not merely a matter of accumulating new facts or learning a new skill. In conceptual change, an existing conception is fundamentally changed or even replaced, and becomes the conceptual framework used by students to solve problems, explain phenomena and function within their world (Taylor, 2001).

Treagust and Duit (2008) state that the teacher makes learners aware of their unacceptable alternative framework by creating dissatisfaction. The teacher then intrudes

a new acceptable framework, but introducing the new framework can limit the learners' use of the newly obtained concepts to only a small part of the context. The best learners can come up with a synthetic concept, where they combine only a small part of the new one with the existing one.

Treagust and Duit (2008) concur that if the learner was dissatisfied with the existing concept, there could be an opportunity for conceptual change. However, the learner has to be supplied with an acceptable replacement concept, and then needs to find the replacement concept intelligible, plausible and fruitfulness for accommodation to occur. Another very important step in the learning process (implementing conceptual change) is for the learners to talk about or discuss their existing or newly formed concepts (Wing-Mui, 2002), thereby becoming active members of learning in the conceptual change model (Mistades, 2009)

Learning involves changing learners' conception and adding new knowledge to what is already there. This view was developed into a theory of learning as conceptual change or constructivism by Posner, Strike, Hewson and Gertzog (1982) and explained by Hewson (1982). The conceptual change theory described the conditions under which a learner will change one explanation for another. Posner et al, (1982) and Hewson (1981) indicated that learning involves an interaction between new and existing conceptions with the outcome being dependent on the nature of the interaction. If these conceptions cannot be reconciled, learning requires that existing conceptions be restructured or even exchanged for the new.

Conceptual change involves some techniques such as accommodation, reconstructing and replacing a concept (Taylor, 2001). Different models have been developed for conceptual change. Scott, Asoko and Driver (1991) have identified two main groupings of strategies to promote conceptual change. The first grouping consisted of strategies which are based upon cognitive conflict and the resolution of conflicting perspectives. The second grouping was of strategies which build on learners' existing ideas and extend them, by way of metaphor or analogy, to a new domain.

Underlying these two groupings were different emphases on where the balance of responsibility for promoting conceptual change in learners may lie. Strategies which emphasize conceptual conflict and the resolution of what conflict by the learner may be seen to derive from the Piagetian view of learning in which the learners active part in reorganizing their knowledge was central. The strategies which build on learners' existing knowledge schemes, extending them to new domains, may be seen to place less emphasis on the role of accommodation by the learner and instead focus on the design of appropriate interventions by the teachers to provide scaffolding for new ways of thinking.

Educator can provide these criteria using the conceptual change model. Conceptual change cannot be obtained through regular instruction. In order to elicit it, the educator should use some instructional strategies. In the conceptual change model the educator asks learners to predict what would happen in a given situation related to science concepts, before being presented with information that demonstrates the inconsistency between common misconceptions and scientific conceptions (Chamber & Andre, 1997).

WESTERN CAPE

The educator cannot change the learner's cognitive structure; only the learner can change it. Wing-Mui (2002) supplies the following teaching strategies to help learners with their conceptual reconstruction:

- Firstly, identify the learner's ideas (or views).
- Create certain opportunities for learners to explore their own perceptions. This is done to test the learner's ideas on events or situations.
- Provide enough stimuli for learners to further develop or modify their ideas; or change the wrong idea into the correct one.
- Provide enough scaffolding for learners to reconstruct their ideas.

## **2.6 MISCONCEPTIONS**

Students do not change their minds easily, so they often resist change. As a result, it takes them a long time to learn the right scientific terms (Schmidt, 1997). In this process a misconception is not a wrong answer caused by faulty or missing information, but information that is completely different from the scientific definition of a concept. If learners' try to defend their wrong answers with some reasons, and they are positive about that, then we should speak of misconceptions.

Poor and incorrect knowledge presentation in textbooks, teachers' incorrect or lack of knowledge about the topics and students' incorrect knowledge learned before their school life can cause misconceptions. A large number of research studies in physics education have focused on students' understanding of electrical concepts. Every day, we come across physics in various fields, and in different ways. This gives us a general idea about some of the concepts in physics. However, sometimes these concepts, which have developed in line with our past lives, do not match scientific facts. Those lives that do not overlap with scientific facts lead to misconceptions. That brings out learners' old knowledge, corrects the misconceptions if there are any, makes up for missing information, and finally enables them to participate in class actively. In addition, it gives examples to learners from daily life so that they can associate their old knowledge with the new. It also encourages the learners to adopt new scientific methods.

The various studies illustrate that one of the most critical issues in teaching science is the occurrence of misconceptions. Overcoming those and ensuing deficiencies has a major role in making learning effective and permanent (Osborne and Freyberk, 1996). In the studies that aim to convert learners' misconceptions into scientific understanding so as to develop personal conceptual image schemas, researchers generally use conceptual change texts, concept mapping, analogies and extra materials (Stavy, 1991).

Conceptual change texts specify students' misconceptions, clarify their reasons and, with solid examples, explain why they are not good enough (Guzzetti et al, 1997). These texts

always start with a question to activate that particular misconception in the students' minds. In the next step, the most commonly misconceptions regarding the topic are presented and, being presented with various evidences, students are convinced why they are wrong. Here, the purpose is to enable learners to question those concepts, and recognize the inadequacy of what they know. When they are able to do so, they are provided with a new set of information and examples to replace the misconception in their minds with the correct one.

However, misconceptions are deeply held beliefs that fail to provide a complete and accurate description of the scientific world (Keig, 1990). Hence, conceptual change process must be considered with utmost care and knowledge must be counterbalanced. To achieve this, learners must be actively engaged in wrestling with the phenomena, problems or questions and willingly commit themselves to the cognitive struggle of restructuring. They must be motivated to actively confront the inconsistencies or contradictions relating to their misconceptions and the phenomena. If learners perceive an inconsistency and accept the intellectual challenge of resolving it, the teacher may be able to provoke the cognitive restructuring to a more sophisticated conceptual understanding (Hyde et al., 1989).

## **2.7 Studies based on Conceptual Change Approach**

The basic idea of science instruction for conceptual change model is simple. It is based on the constructivist notion that all learning is a process of personal construction and that students, given an opportunity, will construct a scientifically orthodox conception of physical phenomena if they see that the scientific conception is superior to their pre-instruction conception (Posner et al, 1982). Teo and Gay (2006) define a concept as a perceived regularity in a record of individual events or individual objects; or a combination of events and objects, which is usually being labelled. Specific concepts of the topic are found in the field electricity and magnetism.

Pitchimal et al., (2014) and Rankhumise et al, (2014) both conducted an investigation regarding the effect of the use of the teaching strategies that can promote conceptual change in the teaching of the principle of conservation of mechanical energy. Pitchimal et al. used the predict-observe-explain (POE) teaching strategy whereas Rankhumise et al. (2014) used the inquiry-based teaching strategy. Both authors used the pre- and the post-tests as the research instrument for collecting data although one is in the form of a questionnaire whereas the other is in the form of multiple- choice questions. The data of both studies were statistically analyzed. The results signified that teaching strategies used in the instructional intervention were effective in reducing learners' alternative concept in electricity.

Further research could contribute to fill a gap in both studies. Both of them look at conceptual change from the epistemological and ontological points of view because in the individual intervention programs the concepts being investigated are described and their nature taken to consideration. The affective view was not considered nor implemented. It is said that a good teacher teaches but a great teacher inspires; therefore, creating an environment that supports learning motivates learners to learn. Furthermore, by integrating technology into teaching and learning, the 21<sup>st</sup> century skill in the form of computer simulations has not been used so far as a learning tool to support conceptual change in the teaching of the abstract concept of electricity and electric circuits.

Computer simulations arouse interest in learners and have been shown to be effective in fostering conceptual change in several studies (e.g., Zietsman & Hewson, 1986; White & Horwitz, 1988; McDermott, 1990; Gorsky & Finegold, 1992). Making use of simulation-based activities on electric circuits in the learning process will promote cognitive learning and allow the learners to works at their own pace, giving them the opportunity to repeat a learning event over and over again whilst trying to understand the concept in the learning process. Learning becomes meaningful because it is a gradual process that is not forced at that instant. It is used as trial and error without causing harm to learners.



## 2.8 Related studies based on electric circuit

Jaakkola and Nurmi (2008) and Lemmer and Edwards (2007) found that some study materials or textbooks on electricity do not alter learners' misconceptions. These textbooks fail to apply the constructivist principle of taking learners' alternative conceptions into account before a new concept is introduced. This situation is aggravated by lack of skills in choosing the appropriate textbook for learners (Lemmer et al., 2008). Consequently, this study intends to develop the electrical circuit learning programme that would be user friendly to grade 10 learners.

To foster the understanding of concepts related to simple electric circuits Ates (2005), Engelhardt, Gray and Rebeilo (2004) and Slaiter et al., (2000) have used the Evans' study (as cited in Baser, 2006) for a teaching strategy of batteries and bulbs. However, the strategy could not eliminate all misconceptions that learners have. It was concluded that the strategy of bulb and batteries could become more effective if educators and mediators of the learning process while learners take the foremost role. Ronen and Eliahu (2000) warn that some deep misconceptions may not be altered by direct experience with simple electric circuits. Therefore, good learning strategies in electrical circuit is still an argument.

In Physical Science literature, there are many teaching strategies to address the misconceptions in teaching electric circuits (Baser, 2006). Some of the many researches are mentioned by Hüseyin Küçüközer and Neşet Demirci (2008). They mention that a lot has been done to determine learners' misconceptions about simple electric circuits in primary, secondary as well as tertiary level (Kärrqvist 1985; Lee and Law 2001; McDermott and Shaffer 1992; Shipstone et.al. 1988; Osborne 1983; Tiberghien 1983; Küçüközer 2003). They gave the following summary of students' misconceptions about simple electric circuits:

- Current is consumed by its closed circuits components (like bulb, resistance, etc.). Therefore, the current is diminished when it returns to battery.



- Current as collisions. The current comes both polar of the battery, and when they collide on the bulb, the bulb gives the light.
- One polar current model. The only need is one connection between battery and bulb. Second connection to the other polar of the battery is not necessary for giving the light.
- Battery is seen as stationary source of current.
- The more battery in the circuits, the more brightness of the bulb.
- Using the concept of current, energy and potential difference for one another.
- The thought of brightness of the bulb to is seen as “sequential reasoning” model. When it considers the path of the current is one way in the series circuits according to this current path, some changes before or in front of the bulb affect the brightness of the bulb, but some changes after or backward of bulb does not affect the brightness of the bulb.
- When bulbs are connected each other with parallel, the current splits as equally to bulbs no matter bulb’s value of the resistance is low or high.

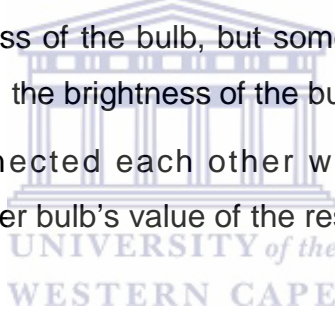

This study has discovered that learners make little effort to change their own pre-conceptions during the learning process. An investigation of learners’ performance in electric circuits with the use of CCM was used as the basic model of teaching electric circuits to learners who have barriers regarding science concepts, supported by the Constructivist Theory (Çalik et al., 2007; Duit & Treagust, 2008), Social Constructivist Theory (Pollard, 1997) and Cognitive Learning Theory (Schunk, 2000).

Wesi (2003) in his study on electricity with science teachers revealed that they have alternative conceptions. In support to this finding Küçüközer and Demirci (2008) and Pardham and Bano (2001) observed that the existence of misconceptions in learners’ minds during teaching sometimes depends on the extent to which teachers identify these misconceptions. These findings initiate a necessary search for a simple and better electric

circuits' learning tool which may enable learners to ingest circuits concepts better. This study was conducted against this background. The purpose was to examine the impact of CCM on learners' performance in simple electric circuit. The research question this study tries to answer is: **How effective was the conceptual change approach in improving learners' understanding of electric circuits?**

Most of the ideas, concepts and theories of the learners come created from their social context and this was taken into account. It is a statement also confirmed by Robottom (2004) and Ausubel (1998). In another source practical work is seen as a practise which first focused on the proof of the existing laws (Roychoudhury, 1996). For Ohms Law, the experiment was done in class in order to reinforce what was learned during the intervention lesson.

According to McDonald's (1998) learning was demonstrated in various schools where there was a shortage of science equipment. In some instances, the equipment was borrowed from other schools and it was noted that at times the equipment was strange to the learners and even to the educators. Sometimes educators have difficulties in using apparatus and the equipment as stipulated (Muwanga Zake, 1998). Laboratories are important in the teaching and learning of Physical Science because it is where the practical works are done in preparing the learners for life-long learning, society and work. Performing Ohm's practically was a way of preparing the learners to the world of electricians (electrical engineering). It has been established that learners' higher order thinking skills are improved when they do practical work (Makgato & Mji, 2006).

Relating to the South African context Dega (2012) investigates the effect of conceptual change through cognitive perturbation using physics interactive simulations in electricity and magnetism. The categorization of learners' conceptions was based on the epistemological and ontological descriptions of these concepts. In qualitative results, six categories of alternative conceptions were identified. They are naïve physics, lateral alternative conceptions, ontological alternative conceptions, mixed conceptions and loose

ideas. It was concluded that there is a statistically significant difference between cognitive perturbation using physics interactive simulations (CPS) and cognitive conflict using physics interactive simulations (CCS) in changing learners' alternative conceptions. It was suggested that in conceptual areas of electricity and magnetism, cognitive perturbation through interactive simulations is more effective than cognitive conflict through interactive simulations in facilitating conceptual change and thus should guide classroom instruction in the area.

Rankhumise (2014) reports on the findings of the study that investigated the effect of a bicycle analogy in alleviating alternative conceptions and other conceptual difficulties about electric circuits. The research methodology is not clearly stated. Only one research instrument was used for the pre- and post-tests which was in the form of a test and such instrument is unreliable because it was not triangulated. The learning strategy perspective supporting the analogy used for conceptual change was not stated. Even the learning events that triggered conceptual change were not explained under the intervention stage. However, data analysis showed a normalized gain score of 0,4 between the pre and post-tests. The results signified that the instructional intervention, involving the use of the bicycle analogy, had been effective in significantly alleviating the alternative conceptions and other conceptual difficulties about electric circuits held by the learners.

Kapartzianis (2014) investigates the vocational students' conceptual understanding of electricity by proposing a multi-dimensional and pragmatic approach to conceptual change. Unlike the previous researcher, the mixed methods employed are clearly stated. The three research instruments for collecting data are the test, the interview schedule and the field notes to triangulate data collected. Test scores indicated that there was a statistically significant difference between the students' pre- and post-test scores. The majority of students during post-test interviews justified their answers incorrectly, but more than 80% answered correctly in the post-test. Qualitatively, the interviews and field notes were analyzed.

## 2.6. Conclusion

This chapter considered the theoretical frameworks and the relevant literature that impacts on this study. The next chapter outlines the research methodology.



## CHAPTER 3

---

### METHODOLOGY

---

#### 3.1. INTRODUCTION

The chapter firstly describes the research methodology in terms of its approach, design, context, learners and methods that were used to collect, analyze and verify the data predicted to assist the researcher in answering the research question above. The purpose of this chapter is to give a detailed explanation of the research design, methodology to be employed, to collection/ gathering of research data and the justification for the choice of research method employed. The study is focused on addressing the following main research question: **How effective was the conceptual change approach in improving learners' understanding of electric circuits?**

Finally, the chapter concludes with the ethical considerations that the researcher endeavors to support while conducting this study.

#### 3.2. RESEARCH DESIGN

Research design is a fundamental ingredient of any research project which can significantly influence the reliability and validity attributed to it (Gilbert, 2001). This study employed a mixed method design. Mixed method means research that involves the application of quantitative and qualitative methods. Quantitative research means that data has been collected and is analyzed using mathematical based methods (Muijs, 2011). Quantitative methods focus on testing explanations, capturing of standardized data and statistical analysis (Johnson and Onwuegbuzie, 2004). The strength of quantitative research lies in its reliability (repeatability) – the same measurements should yield the same results time after time (Babbie and Mouton, 2001). The researcher built complex, holistic picture, analyses words, reports detailed views of learners and conducts the study in natural setting. It allows the researcher to “appreciate the uniqueness and complexity of the case, its embeddedness and interaction with its contexts” (Stake, 1995). Qualitative

research is defined by (Creswell, 2009) as “an inquiry process of understanding based on distinct methodological traditions of inquiry that explore a social of human problem.” Mkhonto (2010) further revealed that qualitative research methodology involves gaining an understanding of a particular phenomenon. It enables the researcher to explore the phenomenon in depth, putting emphasis on the process rather than on results, and allowing insights into change processes (Babbie & Mouton, 2001; Denzin & Lincoln, 2005; Silverman, 2006).

Further features of qualitative research as stated by Hancock (1998) are:

- Qualitative research is concerned with the opinions and feelings of individuals producing subjective results.
- Qualitative research describes social phenomena as they occur naturally.
- Understanding of a social situation is gained through a holistic perspective.
- The intensive and time-consuming nature of data collection necessitates the use of small samples.
- Data collection is time consuming.
- Data are used to develop concepts and theories that help us to understand the social world.
- Qualitative research is deductive in that it tests theories which have already been proposed.

Mixed methods are used in triangulation, since every approach has its strengths and weaknesses. Therefore, a combination of both qualitative and quantitative approaches increases validity (Babbie & Mouton, 2001). For the quantitative part of the study, pre-test and post-test design (Creswell, 2009) was used to determine the effectiveness of the intervention teaching strategy. Qualitative data collected by means of video recordings during the was used to clarify the quantitative findings. The use of both methods strengthens the validation of the data collected.

### **3.2.1. Case study**

This study was conducted as a case study as the research was done in one school and one Grade 10 Physical Science class. A case study is defined as “an exploration of a bounded system or a case over time through detailed and in-depth data collection involving multiple sources of information and in-depth data collection involving multiple sources of information rich in context” (Creswell, 1998). The aim of using a single case study was to find an in-depth information as far as the concept of electricity and electric circuits is concerned. In a similar vein Yin (1989) defines a case study as “an empirical inquiry that investigates a contemporary phenomenon within its real life context; when the boundaries between phenomenon and context are not clearly evident; and in which multiple sources of evidence are used. A case study does not rely on any particular method of data collection, therefore, any method of data collection can be employed” (Merriam, 1988; Yin, 2007).

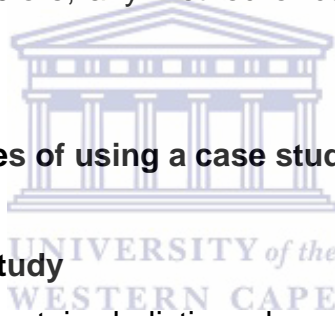

#### **Advantages and disadvantages of using a case study**

##### **Advantages of using a case study**

- It allows for investigation, retains holistic and meaningful characteristics of real life events.
- It is an organisational and managerial process concerning itself with neighbourhood change.

##### **Disadvantages of using a case study**

- Case studies have been viewed as a less desirable form of inquiry and its greatest concern is the lack of rigour.
- Bias and equivocal evidence presents itself and influences the direction of the findings and its conclusions.
- It provides a little bias for scientific generalisation (Yin, 1989).

### 3.2.2. The Research sample

Frankfort-Nachmias & Leon-Guerrero (1997) simply put a sample as the collection of people who were selected for a given research study. Sampling refers to a process of selecting a portion of the population to represent the entire population. A sample is a subgroup of people, animals or objects selected to present the much larger population. Forty learners who were doing Physical Science in Grade 10 and which were of mixed gender. This class was the only class that was taught by the researcher. The sample is summarised in table 4 below:

**Table 3: Sampling of participants**

Activity	SAMPLE SIZE	SELECTION TECHNIQUES	CRITERIA
Pre- and post tests	40 learners	Purposive	Grade 10 Physical Sciences learners taught by the researcher.
Intervention lessons	40 learners divided into 5 groups of 8	Randomly selected	Random selection
Focus group interview	5 learners	One learner from each group	Random selection from each group

### 3.3 DATA COLLECTION PLAN

A data collection plan is a detailed document which describes the exact steps as well as the sequence that needs to be followed in gathering the data for the study. The data collection plan in table 4 below followed the three steps mentioned in the methodological framework. The first step was a pre-test which is attached on the Appendix B (in the form of a multiple-choice questions). The concept plan to establish learners' alternative conceptions is based on conceptual content of the electric circuits. It is a multiple-choice test with a combination of conceptual knowledge as a correct answer and alternative conceptions as distracters, because so far no test has been developed to test alternative



conceptions alone. Learners also constructed conceptual plans that were used to develop lessons for the intervention program. The pre-test had 10 multiple-choice questions with three options each and can be seen in Appendix B.

**Table 4: Methodological framework.**

Research Question	Method	Instrument	Respondents	Analysis
<b>How effective was the conceptual change approach in improving learners' understanding of electric circuits?</b>				
<b>Step 1: What were the learners initial understanding of electricity and electrical circuits?</b>	Pre-test	Baseline test that determined learners content knowledge	Learners	Memorandum
<b>Step 2: How was the conceptual change approach used to teach electricity and electric circuits?</b>	Intervention: - <ul style="list-style-type: none"> <li>•Lesson presentation –(videotape)</li> <li>•Practical investigation (worksheet)</li> <li>•Lesson presentation – Phet simulation</li> <li>•Practical activity (Class exercise)</li> </ul>	Lesson plans are used to enhance understanding and promote conceptual change of concepts through the four stages of conceptual change which are: dissatisfaction, plausibility, intelligibility and fruitfulness  An observation schedule used to look at all the perspectives of conceptual change approach.	Learners	Evaluate concepts for dissatisfaction, plausibility, intelligibility and fruitfulness.  Observation schedule  Thick description
<b>Step 3: What were learners' understanding of electricity and electric circuits after the conceptual change lessons?</b>	Post test	Post-test	Learners	Memorandum
<b>Step 4: What were learners' perceptions of the conceptual change approach to teaching?</b>	Semi-structured - focus group interviews	An interview schedule	Five learners	Transcribe, translate, categorise into themes, coding

Learners constructed concept plans after instruction to inform the interview items to be included in the interview schedule. Semi-structured interviews were conducted in the researcher's school after the post-test. The interviewees were the five grade10 learners who participated in the conceptual change intervention. These five learners were grouped into a focus group. A focus group is defined as a research technique that collects qualitative data through group interaction on a topic determined by the researcher (Morgan, 1996). An interview schedule (Appendix D) was drawn up and face-to-face interviews were conducted after school. Interviewee were allowed to respond in the language that were comfortable at and all responses were video-recorded. This study supports the data obtained with both quantitative and qualitative methods. This means, the results of the focus groups interview will help to understand the quantitative results of data collected with diagnostic pre- and concept planning. The methodological framework that was followed are represented in Table 4.

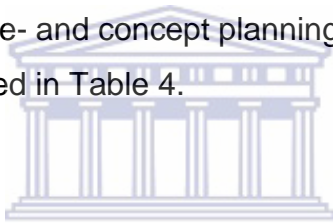

### **3.4. INSTRUMENTS**

Research instruments are a way of collecting data concerning the research. Gathering data using different research instruments is in fact creating different ways to study the social event being researched as indicated by Johannes (2005). The researcher must ensure that instruments are valid and reliable in order to acquire the expected results. The instruments used were tests, interviews and practical investigation. According to Cohen, Manion and Morrison (2008) there is no single prescription concerning instruments to be used for data collection; the criteria for choice should be “fitness for purpose”. In order to collect data for this study, the following instruments were used and the data was collected according to the research questions.

#### **3.4.1. PRE – TEST**

The first step was a pre-test (see Appendix B) in the form of a written test and was used to gain learners' prior knowledge on electricity concepts. Test are means by which the presence, quality or genuineness of something is determined. A pre-test is a preliminary exercise administered to determine a student's baseline knowledge or preparedness for

an educational experience or course of study. It is also used as a guide in the preparation of intervention lessons. The short test was used as a baseline assessment to check the participant's understanding of electricity and was thereupon marked and the results were captured.

### **3.4.2. INTERVIEW SCHEDULE**

The interview schedule was used as an instrument for the study. Scott and Usher (2011) examines interviews as essential tools in educational research with pre-conceptions, perceptions and beliefs of social actors in educational setting which form important part of the backdrop of social interaction. Frey and Oishi (1995) define interviews as a purposive conversation in which one person asks prepared questions (interviewer) and another answers them (interviewee). According to Morse (1998) interviews can use the language that is best known to the respondent in order for him/ her to understand what is being asked. Since interviews are conducted for a specific purpose and are not an ordinary daily exercise (Dyer, 1995), the researcher arranged a convenient day and time and the participants were informed well in advance. This was to make sure that there would be adequate time for in-depth answers. Beforehand, the researcher made sure that the participants understood the nature and purpose of the study and also obtained the participants permission to record the interviews, assuring them of confidentiality.

Semi-structured interviews were conducted on a focus group of five learners and they all gave their consent before proceeding. The learners participating in the research were interviewed after school when everyone else had left and took place in a secure and relaxed atmosphere. Consequently, the participants were able to talk freely and without interruption. This motivated them, thereby enabling the researcher to collect accurate and trustworthy data. This is referred to as 'potential means of pure information transfer' (Cohen, Manion, and Morrison, 2011). The researcher interviewed the participants in a conversational way, structured and controlled by the interviewer to elicit implicit and explicit information that is related to the aims of the study. The study questions were planned but flexible in order to allow the learners' response to form the basis of the next question. This is because the interview helps in not seeing participants as mere data to

be manipulated, but as subjects that can reason and generate knowledge which can be retrieved through interviews (Kvale, 1996).

The interview of the participants is most essential at this juncture because it allowed the researcher to gain an in-depth understanding of events and practices that were observed in the classroom. An interview schedule (Appendix D) was designed and it was used to determine the conceptual change and learning gains accomplished due to intervention. Six open-ended conceptual questions from the concepts of electric circuits were prepared for the interview, following Creswell's suggestion that "a few questions place emphasis on learning information from participants, rather than learning what the researcher seeks to know" (Creswell, 2008). Every member of the group was expected to participate actively in the interview. According to the progress made during the interviews, additional questions were asked in some instances. Learners' were interviewed for between 30 to 40 minutes.

### **3.4.3. Practical Investigation**

After the lesson intervention, the learners were divided into five groups of eight. Each group had to conduct a practical demonstration. They were provided with equipment and a practical guideline. A brief explanation was given to enable them to do the investigation on their own. The researcher observed them as they continued. An observation checklist was completed as the learners continued doing the practical. They followed the guidelines and performed all the steps of the experiment. The experiment acts as a reinforcement of the lesson presentation. The practical guideline is attached in Appendix E. Learners are expected to connect a simple circuit to check if the bulbs are glowing and the cells are in good condition. They have to connect series and observe what is happening, the same with the parallel connection. They must take readings, but for them to do that they have to connect the ammeter and voltmeter correctly and use the correct apparatus for each instant. The researcher recorded how they operate the apparatus and the manner in which they took readings. The learners are expected to be able to draw the two distinctive connections and be able to differentiate between them. They must be able to

deduce conclusion from what they observe during the practical investigation. They must discuss their result and draw up a relevant conclusion.

#### **3.4.4 Intervention Program**

For the conceptual change model the first and foremost significant step in teaching is to make learners aware of their own ideas about the topic being studied. The pre-test and the concept map were used to determine the learners' alternative conceptions and to serve as a guide in the preparation of intervention lessons.

The lesson implementation followed, using the conceptual change approach. Three carefully prepared lessons (Appendix H) incorporating practical work and computer simulations to support conceptual change teaching strategies were prepared and the sample population of thirty learners taught intensively. The interactive simulations were meant to support their learning process as they went about investigating the concept of electric circuits. These simulations were selected from the PhET website <http://PhET.colorado.edu> online free distribution. The basis for their selection was the contents of the concepts selected for the study. In short, the simulations were believed to support and make learners' interactive in their learning process. A lesson involved an exposition of the concept of electric circuits to allow learners to compare their conception with the scientific knowledge. The lesson was prepared such that it met the four conditions of conceptual change.

Lessons (Appendix H) explored building of simple circuit using appliances; series and parallel circuits and bulbs becoming bright or dim. The four conditions of conceptual change were taken into consideration when the lesson was prepared.

#### **Dissatisfaction:**

The lessons were introduced using an exposing event where learners were to make a hypothesis or answer questions and thereafter explain the basis of their prediction or

answer. Group answers were supported with written descriptions that were presented to the whole class. For motivation in the learning process, correct answers with reasons for the choice were voted for by all the groups. Adding to this the teacher would do an experimental demonstration that answered the question. This was done to prompt learner dissatisfaction with their original conception as the teacher and the learners evaluated all the groups' presentations. The conceptual change strategy was supported by the inquiry method, co-operative learning, discussions and direct instruction to provide a rationale for dissatisfaction with their original conception. Learners wrote down all their misconceptions on flash cards.

### **Intelligibility:**

The scientific viewpoint could be considered, discussed, experienced and deliberated in groups. A practical demonstration in a form of Phet simulation was used and during inquiry/ investigations learners watched the activities as they were demonstrated on the board. As it is important to give feedback after the exercise it is also important for the learner to become an active member of learning in the conceptual change model (Mistades, 2009). From the trends and relationships between quantities discovered learners could make more sense of what was taught and slowly reconstruct their conception such that it becomes acceptable in any situation.

### **Plausibility:**

Electricity is the flow of charge. Learners observed that on the board and on the multi-meter. The flow of charge can move from positive to negative and negative to positive. Learners were able to pick that up on the Phet simulation and on the multi-meter by observing a negative value for negative to positive flow of charge. They were able to observe a bright light of bulbs in parallel connection and dim light bulbs for series connection. They took readings for the current flowing and potential difference of the two connection.

**Fruitfulness:**

In addition, with these simulations learners' gained in-depth knowledge of the concepts under investigation and made connections with real-life situations and also with their own prior knowledge (plausibility). To do this they tried to give some examples about the natural events and daily life experiences related to their new conceptions (fruitfulness of acquired concepts). This allowed learners the opportunity to consider the scientific viewpoint as plausible and intelligible and they were exposed to real-life application of electric circuits. The next task was to go home and write down a list of all electric appliances at their homes, the duration they were working and their power consumption. They were instructed to calculate how their households consume electricity and they had to advise on how to save electricity. Figure 3 below shows the steps of conceptual change approach.

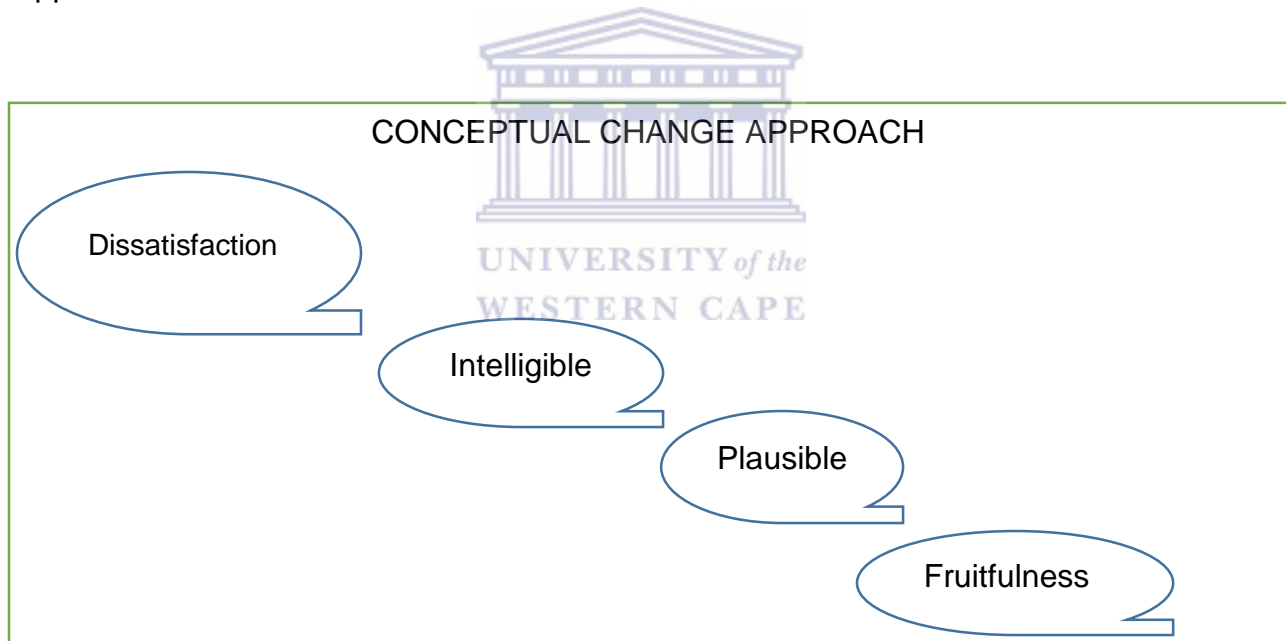

Figure 3: The flow diagram showing the four steps of conceptual change approach.

**3.4.5 PILOT STUDY**

A pilot study was conducted at a neighboring school where they had already completed the section on electric circuits. This was to determine whether the instruments were viable for application in the research. As a result of the pilot study, the researcher was able to refine and restructure the data gathering instruments in preparation for the study. Issues



of language and time to complete the pre- and post-test were identified and corrected. The questions set in the interview schedule were also modified according to the feedback that was obtained. The aim of the pilot study was to identify the ambiguous and unclear questions or items in the instruments.

#### **3.4.6 POST – TEST**

A post-test was drawn to test the learners understanding from the background knowledge and after all the interventions. The twenty learners were given a practical worksheet which they have to complete it. The practical worksheet contains few questions that regarding general questions on electricity and its applications. The same participants were given practical worksheets to carry out practical based on the investigating that series resistors are potential dividers and parallel resistors are current dividers. They were provided with all the apparatus to conduct the investigation. The researcher used an observation checklist to collected data on how the participants work. All the information was entered in the data table, interpretations were done and graphs and conclusion were drawn. The post-test, similar to the pre-test, followed after formal instruction (Intervention). Semi-structured interviews were conducted in the researcher's school after the post-test.

WESTERN CAPE

The results of the post-test determine the validation of the research. Comparison was drawn from the pre-test and post-test and the manner in which the results were analyzed using Excel program. All these findings were reported in details on the next chapter of findings.

#### **3.4.7 FOCUS GROUP INTERVIEW**

There are three fundamental types of research interviews: structured, semi-structured and unstructured. In this study the researchers opted for the semi- structured interviews in order to obtain a superior depth of information. According to Busha, Harter (1980) the interviewer must be made aware of the form of interview and be made prepared before the questioning process begins. The interviewee was interviewed at a scheduled time. Interviews were conducted after school, as this was not hampering school time or



disturbing tuition time. Forty Physical Sciences learners participated in the conceptual change intervention.

Face-to-face interview allows interviewer to reach a certain number or proportion then they cut off the rest (Muijs, 2011). An interview schedule (Appendix D) has been drawn up and face-to-face interviews was conducted after school. Open-ended questions have the advantages because the learner tends to freely formulate answers without thinking or just guessing the answer. This type of questioning is more difficult and time consuming to work with. As it is time consuming the learners are unlikely not to answer these types of questions. The answers that were captured are coded and categorized into themes and the content was analyzed.

As a researcher it is important to discover opinions or answers that have been cascaded without being taught clearly and an answer that a researcher has not thought before. Whereas the answers were limited, closed-ended question were yes or no answers which do not allow the learner to elaborate further, unless a probing question allows that. The closed-ended questions are broader and including a range of question type (Muijs, 2011). Likert scale is used to tabulate the items or themes and rating scale allows the learner to make a choice of several options that will indicate the degree or level of agreement or opinion on the listed items. Rating scaling can have different forms and categorize that entail your research themes. The researcher used both types of questioning in this research, and the closed questions consisted of probing question to get more information from the learner.

The test and interview schedule set in this research consisted of both questioning and probing questions so to get more information from the learners. In this study, formula in excel was used to analyze learners results that was collected and entered to a data analysis sheet. In Table 5, the content and points awarded to each of the categories used in the study were presented. The pre-test and post-test was written in the afternoon as the learners must have enough time to look through their own work. The data recording sheet with the learners' marks was completed after the learners' answer sheets have

been marked learners' answers for the test was scored according to the marking memorandum on appendix B. All learners' total scores for pre- test and post-test was calculated and recorded on a data recording sheet.

The comparison of pre-test and post-test scores was analyzed using the answers provided by them. The data from the interviews with the learners was transcribed verbatim and translated where necessary. The next step was to scan and clean the records to eliminate unnecessary data. The interviewee was allowed to respond in the language of their choice and all responses were audio-recorded. The interviewee was given codes that would identify them with as this serve to hide their identities. The following table shows how the codes were given for each learners.

**Table 6: Coding for the interviewee.**

Learners	Group 1	Group 2	Group 3	Group 4	Group 5
Codes	G 1	G 2	G 3	G 4	G 5

### **Advantages and disadvantages of interviews and focus group interviews**

#### **Advantages of interviews.**

- ❖ Interviews help the researcher to have control over the topic as well as the format of the interview.
- ❖ Prompting may be included regarding questions and if an inappropriate question asked.
- ❖ Assist the researcher to record the data on why no responses were made (David and Sutton, 2004)

#### **Disadvantages of interviews**

- ❖ Interviews adhering too closely to the interview guide and may be the cause of not probing for relevant information.
- ❖ Respondents may hear and interpret questions in a different manner since there is a set of interview guide (David and Sutton, 2004)

### **3.5 DATA ANALYSIS**

#### Data analysis and tests

Data analysis is a continuous process of making meaning of the data processes generated from different methods used. Consistent with the interpretative paradigm underpinning the study, analysis thus occurred throughout the research process (Xipu, 2012) Since data analysis is an interactive process involving interpreting and making of such texts (Hitchcock & Hughes, 1989; Creswell, 2003), inductive strategies and constant comparative analysis were used to identify patterns and themes in the data (Stake, 1994).

Using certain criteria in data analysis is a common method because they show the relationships between the data of the study in which learners' understanding levels were investigated via open or closed-ended questions. In this method, learners' answers for the questions were classified and the answers were scored according to these categories. The pre and post-test results was tabulated in MS Word document and analyzed using Excel spreadsheet. The learners' actual marks (for the correct answers) out of 20 and percentages were recorded in a mark list of the class. This mark list contains learners, school, actual marks and percentages obtained in both pre and post-test. The mark list was used to generate tables and graphs that shows the results of the study.

#### Lesson plan and practical investigation

Observation checklist was analyzed and checked to see the level of understanding of learners. The marks captured were analyzed and compared.

#### Semi – structured focus group interview

The learners were given a unique code (G1 – G5) for the sake of confidentiality as indicated in Table 6. Learner's responses from the interviews were analyzed manually and coded for themes. Recordings of interviews were transcribed and read thoroughly to get the sense of the information. The interview data was presented according to the predetermined themes from the interview schedule. Field notes from observations and semi – structured focus group interviews were analyzed one by one, keeping in mind that qualitative data must be coded in order to provide some structure and meaning. The

interview and questionnaire data were synthesized for each learner. Responses were audio-taped and the verbatim was transcribed. The data was translated where necessary. Responses were characterized into key themes. Evidence of similar themes needed to be grouped and reviewed until themes emerged and initial statements were generated to help develop insights and theoretical understanding. The data was color coded and classified into different themes and data recorded. The video-tape of the lesson was examined using an observation schedule.

### **3.6 VALIDATION AND RELIABILITY**

#### **3.6.1. VALIDITY**

Triangulation was used in research methodology. The data collection took place over an extended period of time. Validity issues may be summarized as being mostly remarkable for the unfair, unrealistic measures which they place upon the creativity and imagination of the researcher. Because the studies in conceptual change was qualitative in nature special attention must be paid to triangulation (by having different data sources, or having multiple observers, doing longitudinal observation, using different methods and looking at the data from different theoretical perspectives) which becomes important to ensure that the study has credibility. A valid instrument is one that measures what it is supposed to measure. The validity of the conclusions of this qualitative data was obtained through data triangulation through the use of multiple instruments and different learners. The instruments were reviewed by an external person so as to eliminate any ambiguities and to ensure the necessary rigor.

#### **3.6.2. RELIABILITY**

Reliability is the consistency of an assessment. Rudner and Schafer (2001) argue that the best way to view reliability is the extent to which test measurements are the result of properties of those individuals being measured. Reliability has been defined as “the degree to which test scores for a group of test takers are consistent over repeated applications of a measurement procedure and hence are inferred to be dependable and repeatable for an individual test taker” (Berkowitz, Wolkowitz, Fitch & Kopriva, 2000). In this research, the instruments were carefully structured in an attempt remove all

ambiguities and biases. The instrument was designed to extract learner's true responses. The results of all my tests are correct and are relevant for the concept as they were moderated before given to the learners. Researcher have requested a colleague check and moderate all the instruments before they were written. Bulmer & Warwick (1993) raises important concerns about reliability that for the instrument to be reliable, yield of same results when research done different people and reproduction of achieved results under different conditions.

### **3.7 ETHICAL CONSIDERATIONS**

All learners in this research were made aware that this research was for my studies. They were also informed of their right not to participate, without being interrogated into giving reasons for their decision. For those who were willing to participate, I laid out clearly to the learners my duty to treat them with outmost respect the entire time they were part of the project, if they wanted to pull out whilst the project was in progress, they were free to do so. Indeed, the researcher adhered to the principle of confidentiality and all learners remained anonymous. Permission for the research at school and the education department were obtained prior to the study. Permission in a form of consent from all concern learners was signed prior to the engagement in the research. Learners partaking in the research are learners from schools' samples, the ones to be interviewed, observed. The parent component of learners, SGB, teachers, Principal, DoE and the UWC ethic committee. Avoid harm the learners that are engage in research and ensure that that the research is independent and unbiased. A copy of the consent form and application for conducting research is attached to the appendices 1 - 7.

### **3.8 CONCLUSION**

In this chapter the researcher outlined the research design of the study and justification of research as a technique for determining and establishing how electric circuits were taught using conceptual change approach in grade 10 Physical Sciences. The methodology including administering of number of data gathering strategies, namely, data analysis, lesson presentation, practical presentation, observation checklist and a semi-structured interview were presented. This chapter also explores how data was validated

to ensure quality and trustworthiness. Finally, ethical issues implicated are considered in this chapter. The next chapter present the results and discussion of the findings of the study.



## CHAPTER 4

---

### FINDINGS

---

#### 4.1. INTRODUCTION

The previous chapter outlined the methodology employed to collect the data. This chapter reports on the results obtained and was organized around the data collected to answer the research question:

**How effective was the conceptual change approach in improving learners' understanding of electric circuits?**

- (i) **What was the learners' initial understanding of electrical circuits?**
- (ii) **How was the conceptual change approach used to teach electric circuits?**
- (iii) **What was learners' understanding of electric circuits after the conceptual change lessons?**
- (iv) **What were learners' perceptions of the conceptual change approach to teaching?**

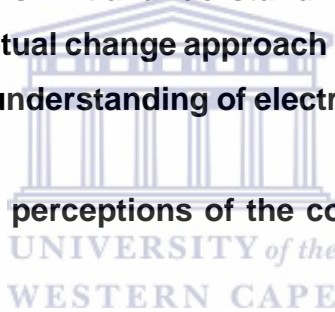

An overall look at learners' performance in the pre-test was first presented prior to a detailed description of the analysis of learners answers. The data collected in terms of pre-test, practical demonstration and post-test was presented. A comparison was made between learners' performance in the pre-test and the post-test as well as their perceptions of the process.

#### 4.2. What was the learners' initial understanding of electric circuits?

In order to elicit learners understanding of electric circuits, they were requested to answer a pre-test. The questions in the pre-test are found in Appendix B. A memorandum to mark the pre-test is attached in Appendix C. The marks obtained by the learners are captured

and tabulated in Table 7 below. The results of the learners' marks were recorded and a question-by-question analysis was done (attached in Appendix I).

The ten questions for the pre-test covers some content of basic electricity that the learners have to know. Each question received one mark and the total mark for the test was 10. The results of the learners' marks were recorded and a question- by-question analysis was done. The analysis included the calculation of the total mark per question, the average mark per question and the average percentage per question. From the results obtained by the learners the average percentage was 29%, as tabulated in Table 7. Graph 1 shows the average mark percentages obtained by each learner.

The achievement in Question 1 was 50%, where learners had to identify that, when the switch was closed, the circuit was complete.

Question 2 (8%) required the learners to understand that when a switch was open, the circuit would break. The test showed that most learners did not understand the concept.

In Question 3 the learner had to show an understanding of what would happen to the brightness of the bulb when one increases the voltage in a single bulb. In this question only a few learners (17 %) showed an understanding.

In Question 4 learners obtained 33%. It tested if they understood the concept of what happens when one increases the voltage and increases the number of bulbs and what would happen to the brightness of the bulbs.

In Question 5 - 8 learners obtained 25%. in Question 5 a learner had to understand what would happen if the bulb goes out when the voltage increases. These questions tested the learners' understanding of the concept.

In Question 6 learners showed less understanding of this concept. The question wanted learners to know what the factors affecting the resistance were; in this case it was the thickness of the wires used.



In Question 7, the scenario was that learners had to know, when the wires were changed, what the effects of the resistance in the circuit would be. In this case it was the thickness of the wires, as well as the nature and the size of the wires. The scenario illustrated a long thick coiled wire. Few learners showed an understanding of this set up.

In Question 8, 9 and 10 learners were asked to identify the symbols used in a simple circuit. The achievement in Question 9 was 40%; most learners knew what the symbol represented in a simple circuit diagram. Question 10 reached 23%, showing that a third of the class could answer it.

Table 7. Pre-test Results analysis

Qn 1	Qn 2	Qn 3	Qn 4	Qn 5	Qn 6	Qn 7	Qn 8	Qn 9	Qn 10
50%	8%	17%	33%	25%	25%	25%	25%	40%	23%

Table 8. Marks obtained by learners in Pre-test.

Surname	Marks/ 10	Percentage
1. Learner 1	3	60%
2. Learner 2	2	40%
3. Learner 3	2	40%
4. Learner 4	3	60%
5. Learner 5	4	80%
6. Learner 6	3	70%
7. Learner 7	3	60%
8. Learner 8	3	60%
9. Learner 9	3	30%
10. Learner 10	3	30%
11. Learner 11	2	70%
12. Learner 12	4	40%

13. Learner 13	3	30%
14. Learner 14	1	10%
15. Learner 15	1	10%
16. Learner 16	3	30%
17. Learner 17	2	20%
18. Learner 18	4	40%
19. Learner 19	3	30%
20. Learner 20	5	50%
21. Learner 21	2	20%
22. Learner 22	3	30%
23. Learner 23	4	40%
24. Learner 24	1	10%
25. Learner 25	2	20%
26. Learner 26	5	50%
27. Learner 27	1	10%
28. Learner 28	4	40%
29. Learner 29	4	40%
30. Learner 30	2	20%
31. Learner 31	3	30%
32. Learner 32	3	30%
33. Learner 33	2	20%
34. Learner 34	6	60%
35. Learner 35	1	10%
36. Learner 36	3	30%
37. Learner 37	3	30%
38. Learner 38	2	20%
39. Learner 39	1	10%
40. Learner 40	4	40%
<b>TOTAL</b>	<b>113</b>	
<b>AVERAGE MARK</b>	<b>3</b>	<b>28%</b>

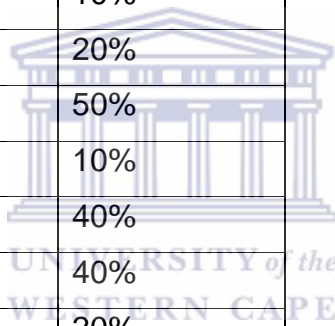

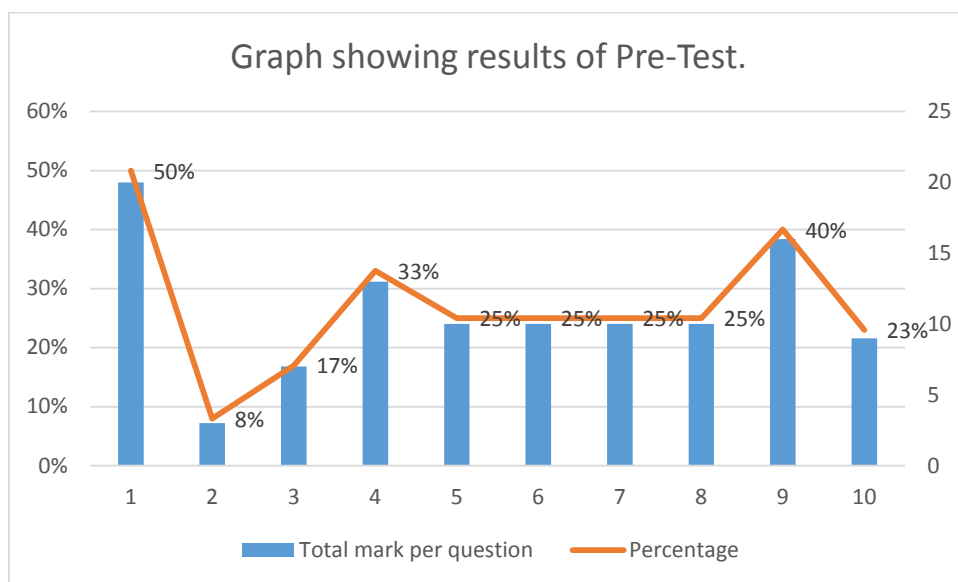

Graph 1. Graph of total marks per question and percentages

### 4.3. Application of a Conceptual Change Approach.

The pre-test was used as a diagnostic assessment and clearly showed the learner level of understanding of electric circuits. In order to improve effective learner understanding in electric circuits, a conceptual change approach was used. Applying the conceptual change strategy involved the following four steps as put forward by Posner, Strike, Hewson & Hertzog (1982), namely (1) Dissatisfaction, (2) Intelligibility, (3) Plausibility and (4) Fruitfulness.

#### 4.3.1. How was the conceptual change approach used to teach electric circuits?

##### (a) Dissatisfaction

Dissatisfaction is the first stage of the Conceptual Change Theory. According to Posner et al (1982), learners must become dissatisfied with their existing conceptions in order for the new information to be acquired. The new conception clash with existing conceptions, therefore this cannot become plausible or fruitful until the learner becomes dissatisfied with the old conceptions. Dissatisfaction is where learners use their existing knowledge. Learners' are unlikely to make major conceptual changes until they believe that are changes. In order to satisfy the concept of electric circuit, a lesson was conducted to the

learners to assess learners' dissatisfaction. The lesson with inquiring questions was presented in order to activate learners' existing knowledge and misconceptions.

During the initial stages of intervention, the educator introduced the lesson to the learners and told them that it was based on electric circuits. The context was the module of Electricity, which was one of the questions asked during the examinations in Physical Sciences Paper One.

When a new concept is introduced to learners their only experience is their environment, and the way they see and experience their world (Meyer, 2014). Individually, learners were allowed to use their own resources like textbooks to write down the definitions to discussed with their peers and then answer the questions. They had to compare the similarities as well as the differences they found.

The following are some of the questions asked and responses from learners. The questions were asked during the first stage of the lesson to activate learners' existing knowledge about electric circuits:

**Educator: What is meant by electricity?**

*Learner 3: It is the electrical energy that supplies us with electricity.*

*Learner 2: It is the power supply which supplies every household with power.*

**Educator: What is a simple electric circuit? Make a diagram to illustrate it.**

*Learner 4: A simple electric circuit is a circuit that consists of a cell, bulb, switch and connecting wires.*

*Learner 8: It is a simple circuit that consists of few apparatuses which are connected together.*

**Educator: What happens when the switch is open?**

*Learner 11: When the switch is open, the electricity won't flow through the circuit and the bulb will not burn.*

*Learner 17: The charges will not flow through the circuit and the bulb will not glow.*

**Educator: Explain what happens when the switch is closed.**

*Learner 15: The electricity will flow throughout the circuit and the bulb will light glow.*

*Learner 21: When the switch is closed, it allows the charge to flow throughout the circuit and the bulb will glow.*

The second session of the concept of electricity is the electric circuits. The educator assessed learners' conceptions by asking questions and allowing them to respond. They were allowed to use their textbooks and discuss their responses as a group. A few of the questions asked and answers given by the learners were:

**Educator: What happens when you increase the number of bulbs in the circuit?**

*Learner 22: The bulbs will glow more and they will be brighter.*

*Learner 29: They will be very bright because there are more of them.*

**Educator: What is meant by series circuit?**

*Learner 24: Series circuit is when you connect the bulbs following one another.*

*Learner 27: It is when you place bulbs next to the other in the same line.*

**Educator: What is meant by parallel circuit?**

*Learner 25: In parallel connection, the bulbs are connected parallel to each other.*

The learners were updated about possible misconceptions related to the occurrences asked in the questions and they were encouraged to discuss these questions. Some of them indicated that with this new information they now had a different image of the concept. The knowledge they had about electric circuit was not what they thought it was. In other words, they were wrong. That concluded the first step in the conceptual change model, namely dissatisfaction with their initial understanding as indicated by Posner et al. (1982).

## **(b) Intelligibility**

Learners used their existing knowledge and understanding of the concept. A new conception must be intelligible (Posner et.al. 1982). It was at this stage where the new concepts were explained. The individual should be able to grasp how experience can be structured by a new conception sufficiently to explore the possibilities essential in it. In order to address the intelligibility, the following lesson was implemented. Activities were prepared and performed by the learners and the educator. Learners were divided into two group of six.

The educator used pHet simulation to build a simple circuit and projected it on to the board. Learners used their textbooks as point of reference on what was to be taught. Learners were allowed to work in groups and discuss everything. The objective of the lesson was to explore electricity and a simple circuit, as well as clear up the notion of the diagrams layout from linear to two dimension.

### **Activity 1 (Explain electricity)**

The learners were expected to take out their drawings of simple circuits and discuss these by comparing them to the ones in their books as well as the one on the board (pHet diagram). They had to look at their own diagrams and compare what they had drawn to the above-mentioned diagrams and discuss the differences. They had to check if they had all the components that make a complete circuit, and identify all the parts that constitute a simple electric circuit.

### **Activity 2 (allow the charges to move)**

During the first discussion of a simple circuit the dots that represent the charges were still, i.e. the switch was open. The educator showed the electricity using the diagram and told learners that the switch will be closed. The question was asked: What is meant by electricity? What happened after the switch was closed? What happened inside the connecting wires? What was observed from the bulb? How was the brightness of the bulb before and after the switch was closed? This had to be discussed as a group and all the responses were written down.

Electricity follows the topic of electrostatic in the Physics syllabus. Learners had already discussed the concept in part. The educator wrote the definition on the board and gave examples.

**Definition: -**

**Electricity** is the flow of charge from one point to another. It is the flow of electrons and protons. Electricity is not a form of energy. Charge is not energy. Since electric charge is permanently attached to certain particles of matter, electricity is a basic component of everyday matter. Objects are made of molecules, which are made of atoms, which are made of tiny particles called protons and electrons. The electrons/protons are made of positive electricity and negative electricity.

The Educator asked one learner in each group to draw a simple electric circuit on the board. They were asked to identify their mistakes and discuss it.

*G2L5: Oh!! I see now where I made a mistake. I drew a wrong cell.*

*G1L3: I can see where I went wrong. It is now clear.*

WESTERN CAPE

**Example:**

The Educator asked a learner to switch on the light. The lights were on. A kettle was also used in class to show the flow of electricity from the plug to the kettle. The water boiled.

After the presentation, learners were asked to give their own example where we apply or use electricity.

*G1L39: An iron.*

*G1L13: Extension connecting a machine.*

*G2L7: A charger charging a phone.*

*G2L9: A headlamp.*

Another new concept of electricity was introduced just after the activation of their prior learning. Furthermore, the educator explained more about the concept of electricity such

as series and parallel connections and factors affecting resistance, and where learners had to learn the differences between them. By so doing, it was to make learners aware of these fundamental electric concepts before demonstrating and enhancing intelligibility. Probing questions were used constantly and learners were given the opportunity to give examples and explain the application of such concept.

### **Activity 3 Series circuit**

Two bulbs were added in the circuit and they were connected in series. The switch was open. The educator showed learners that the switch was open and then asked them what they observed in that circuit. Then the switch was closed again and they were again asked what they observed. How is the brightness of the bulb compare it with the one bulb?

They had to discuss what they observed with each other and they had to write down all their observations. From their perception they saw clearly what took place when bulbs were connected in series.

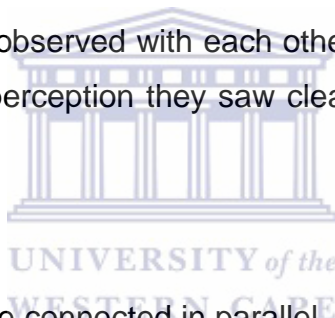

### **Activity 4 Parallel circuit**

Three bulbs were used and were connected in parallel. The switch was left open. Again, the educator told the learners that it was open and that they should observe what was happening. Then the switch was closed and learners observe what was happening afterwards. They had to record their observations. They had to look at the brightness of the bulbs and compare the brightness of series and parallel connection. Make use of two and three for the observations. Record your observations.

In their groups they discussed what they had observed in each activity. This activity clarified the difference between series and parallel connection, brightness of bulbs and the effect of adding more bulbs in the circuit.

#### **Educator: What do you observe from the series circuit?**

*G1L11: In series circuit the bulbs glow dimmer than the single bulb.*

*G2L22: It is seeming as if the charge flows very slowly.*



**Educator: What do you observe from the parallel circuit?**

*G2L15: It looks like the power is very strong, because the bulbs are brighter.*

*G2L24: It is the same circuit, but the bulbs shine brighter than the series connection.*

The Educator added the ammeter and voltmeter in the circuit where learners watched the flow of current in both connections. The learners observed and recorded their observations to use them for comparison. They also watched what happened in the voltage of the two connections and recorded their observations. Examples of series and parallel connections were given by the educator and the learners were asked for examples.

Example:

The street lamps are connected in series and parallel. A Christmas tree is connected in series and parallel.



**Educator: Give me examples of series and parallel circuit?**

*G2L3: The classroom lights are also connected in series and parallel.*

*G2L1: In our homes lights are connected in series and parallel.*

The lesson was concluded by demonstrating the four factors that affect resistance. By using different types of material the educator showed learners how the resistance would be affected; also how that would affect the flow of charge and how this would affect the resistance itself.

This situation supported the second condition of Posner et al.'s (1982) model, namely intelligibility where a new concept is made understandable to learners.

**(c) Plausibility**

A new conception must appear initially plausible. Any new conception adopted must at least appear to have the capability to solve the problems generated by its predecessors, and to fit with other knowledge, experience and help. Otherwise it will not appear a

plausible choice. In order to address plausibility, the following practical investigation have been implemented.

To ensure that learners understood the concepts in electricity and to accomplish plausibility, one of the activities planned was to conduct practical work. This was where learners were exposed to hands-on activities in a practical class. Each learner was given equipment with which to conduct the experiment. The educator read the practical guidelines and the learner listened until they were ready to start the practical. According to the guidelines learners were supposed to make a prediction of what would take place in the practical they were about to do. Learners were expected to follow a scientific method of reporting and show all the steps.

They started with series connection using two or three bulbs. The educator observed what the groups were doing and how they were connecting their apparatus. She used an observation schedule to observe what the learners were doing and they were also videotaped during the process. After the learners completed the connection the educator credited them and started measuring the current of the series connection in different places and taking recordings of what they observed. The educator also checked how learners used the measuring instruments and how accurate they were in taking readings from the ammeter and voltmeter.

A multi-meter was used because some of the ammeters and voltmeters were not working properly and some were broken. The multi-meter needs skills and the educator made sure that the learners knew how to shift from one instrument to another. While moving along the groups the manner in which the learners was collecting their own data was also observed by the educator. The learners collected both current and voltage in the series connection. After they had finished taking readings, just before they disconnect their circuit, they had to make a drawing and show where they have connected the multi-meter for both current and voltage reading.

The Educator must monitor how learners handle the multi-meter when taking readings for current and voltage. Ammeter is connected in series when reading current, whereas voltmeter is connected in parallel to the resistors or battery. When they had completed the drawing they had to disconnect and start the second part.

After taking readings for series connection, the learners had to disconnect and draw a parallel connection using two or three bulbs. They were expected to follow the same procedure as series connection. They measured the current in different positions and the voltage across the battery and the bulbs. In this second round learners showed confidence as they handled the apparatus. They were able to connect without assistance and one could see they felt great about it.

As they were expected to connect bulbs in parallel and continue taking readings they had to follow the same procedure and start connecting the bulbs in parallel and observe. They had to check the glow of the bulbs comparing that to the series connection. Then continued taking readings of the current flowing through in four different place and record their observations. Again the educator observed what the learners were doing and how the results were taken and recorded for their own data. The same as voltage, learners are supposed to observe the voltage in four different places across the circuit. The educator had to monitor the change in the positioning of the multi-meter every time the learners did an observation. Ammeter is connected in series when taking reading current, whereas voltmeter is connected in parallel to the resistors or battery. They had to do the same thing in parallel to measure the voltage in four different places. When they completed taking their readings they had to draw the parallel connection in their worksheet. After that when they were satisfied with their results they could disconnect and pack their apparatus away. The Educator observed and analyzed all the moves filled/ entered in the observation schedule.

The learners had collected data from the previous activity, they then had to fill in the practical worksheet and analyze their own data and write a conclusion. After they finished this they submitted their results. The worksheet was allocated and marked, the whole task

was out of 50 marks. A practical marking guide was used to mark the practical worksheets which is attached in the Appendix F. Learners here reinforced what they have observed during the practical session.

The following table 9 shows the marks that learners have obtained after answering the practical worksheet. The practical worksheet could be completed at home after the practical had been done, and submitted the next day. Some of the learners needed explanation related to unclear information in the worksheet. The Educator collected the practical worksheets, they were marked and the marks were tabled and analyzed using Excel. A graph showing the marks obtained were plotted in a graph. Table 9 below shows the marks that the learners obtained after completion of the practical.

Table 9. Practical task results obtained by learners.

Surname	Marks/ 50	Percentage
1. Learner 1	30	60%
2. Learner 2	20	40%
3. Learner 3	20	40%
4. Learner 4	30	60%
5. Learner 5	40	80%
6. Learner 6	35	70%
7. Learner 7	30	60%
8. Learner 8	30	60%
9. Learner 9	15	30%
10. Learner 10	15	30%
11. Learner 11	35	70%
12. Learner 12	45	90%
13. Learner 13	30	60%
14. Learner 14	20	40%
15. Learner 15	20	40%
16. Learner 16	35	70%
17. Learner 17	30	60%
18. Learner 18	25	50%
19. Learner 19	15	30%

20. Learner 20	35	35%
21. Learner 21	30	30%
22. Learner 22	20	20%
23. Learner 23	30	60%
24. Learner 24	40	80%
25. Learner 25	35	70%
26. Learner 26	20	40%
27. Learner 27	40	80%
28. Learner 28	20	40%
29. Learner 29	15	30%
30. Learner 30	15	30%
31. Learner 31	35	70%
32. Learner 32	20	40%
33. Learner 33	25	50%
34. Learner 34	35	70%
35. Learner 35	15	30%
36. Learner 36	35	70%
37. Learner 37	20	40%
38. Learner 38	30	60%
39. Learner 39	15	30%
40. Learner 40	35	70%
<b>TOTAL</b>	<b>1870</b>	
<b>AVERAGE MARK</b>	<b>37</b>	<b>47%</b>

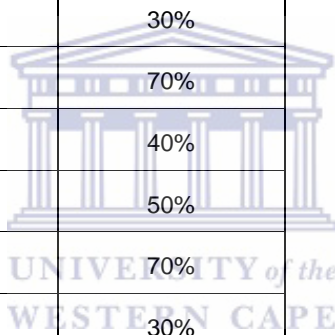

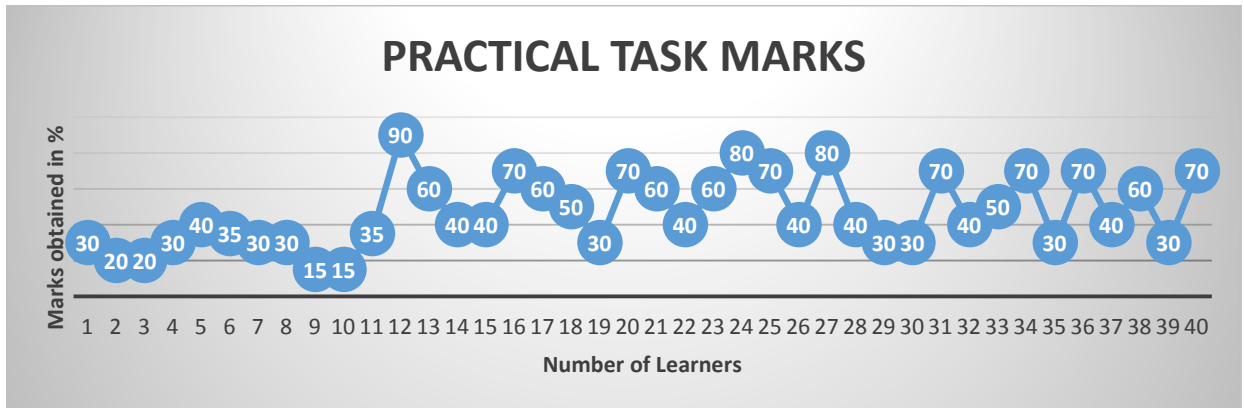

Graph 2. Graph showing the results of the practical task.

Graph 2 above shows how the learners have performed in the practical worksheet they had to complete. It gave a clear indication of their performance. Some of the questions needs their input based on their observations and the data they have collected. Further results will be discussed in the observation schedule.

#### (d) Fruitfulness

A new conception should suggest the possibility of a fruitful research program. It should have the potential to be extended, to open up new areas of inquiry and to have scientific and/or explanatory power.

After the practical investigation, learners continued to discuss the events that are related to electricity and electric circuits. In their discussions, the main aspect was to prove the usefulness of the learned electric conceptions. To provide this, learners tried to give some examples about the natural events and daily life experiences that are related to their new conceptions (fruitfulness of acquired concepts). The educator also gave them some examples where they could see series and parallel connections. The Educator indicated things that they interact with in their daily lives, and asked them to give more examples of uses with these series and parallel connections. The following are some of the examples showing series and parallel connections that were projected for learners by the educator:

Example of series and parallel connections: -

(Pictures of examples showing series and parallel connections in real life)

Learners were given some activities to complete and to reflect on their findings to the groups and also to give some examples of series and parallel connections that occur in everyday lives. Learners were given a task to complete where they wrote all their household electric appliances in a table. They indicated the appliance's power rating and the amount of time the appliance was used per day. Prior to this they brought their pre-paid slip where they have bought electricity for their pre-paid. And they started by calculating the rate they pay for their electricity, as the tariff differs from area to area. It also depends on people's employment or indigents. They used their own rates to calculate how they consumed electricity. Learners calculated their consumption and submitted their class exercise.

Calculations:

$$\begin{aligned} R50.00 &= 32.2 \text{ units/kWh} \div 50.00 \\ &= \mathbf{R 0.64c \text{ per unit/kWh}} \end{aligned}$$

Each and every one used his/her own prepaid paper to calculate the rates. Learners response after they calculated their rates of electricity was.

G1L1: It was so nice to do these calculations.

G1L4: I did not know that we use different rates for our electricity.

G2L3: But ours are the same, but the others differ?

G1L5: It was so exciting and interesting.

The educator explained that the exercise was not meant to undermine families with poor backgrounds, but to teach them how to use electricity wisely and not to waste it. The exercise was marked and the learners enjoyed doing the exercise as it was more practical and it was based on the things they work with on a daily basis.

G2L2: I enjoy doing calculations as I understand the concepts better.

G1L4: We all finished doing the calculations before the set time.

#### 4.4. What was learners' understanding of electric circuits after the conceptual change lessons?

##### POST TEST

Learners wrote a post-test after they completed the experiment and the class activity. The test and the memorandum are attached to the Appendix J and K respectively. The results after marking the test were as shown in table 10 and a graph that illustrate the results is attached below. Learners results of the post-test showed an improvement compared to the pre-test. The graph shows an increase in marks obtained by the learners in the post-test. There are still questions were learners have obtained lower marks but the majority if the questions they have received higher marks.

Table 10. showing the results of the post test.

Surname	Marks/ 30	Percentage
1. Learner 1	24	80%
2. Learner 2	19	63%
3. Learner 3	17	57%
4. Learner 4	22	73%
5. Learner 5	25	83%
6. Learner 6	29	97%
7. Learner 7	25	83%
8. Learner 8	26	87%
9. Learner 9	17	57%
10. Learner 10	20	67%
11. Learner 11	19	63%
12. Learner 12	26	87%
13. Learner 13	23	77%
14. Learner 14	20	67%
15. Learner 15	24	80%
16. Learner 16	22	73%
17. Learner 17	27	90%
18. Learner 18	13	43%
19. Learner 19	18	60%
20. Learner 20	20	67%



21. Learner 21	19	63%
22. Learner 22	23	77%
23. Learner 23	25	83%
24. Learner 24	22	73%
25. Learner 25	29	97%
26. Learner 26	23	77%
27. Learner 27	27	90%
28. Learner 28	14	47%
29. Learner 29	12	40%
30. Learner 30	28	93%
31. Learner 31	23	77%
32. Learner 32	20	67%
33. Learner 33	9	30%
34. Learner 34	22	73%
35. Learner 35	25	83%
36. Learner 36	21	70%
37. Learner 37	13	43%
38. Learner 38	6	20%
39. Learner 39	23	77%
40. Learner 40	20	67%
<b>Total mark per question</b>	<b>840</b>	
<b>Average mark per question</b>	<b>21</b>	
<b>Average % per question</b>		<b>70%</b>

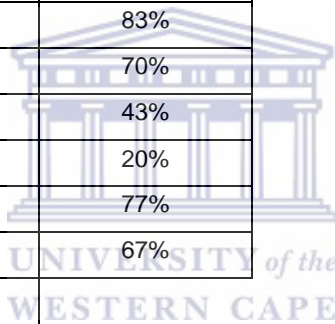

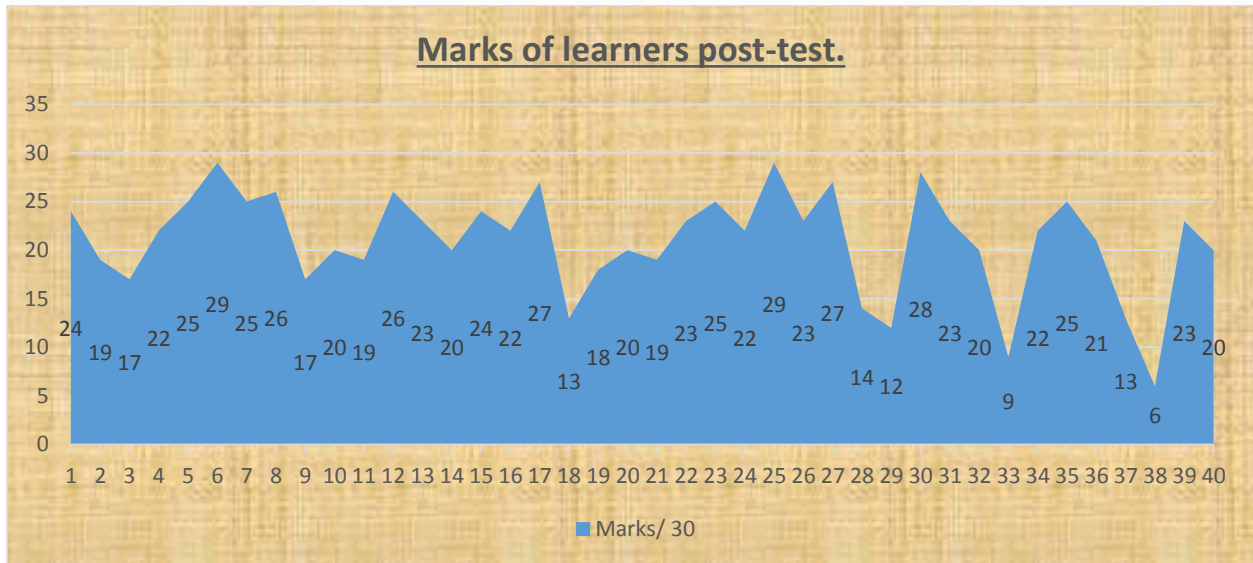

Graph 3. Graph showing the learners results of the post test

#### **4.5 What were the learners' perceptions of the conceptual change approach to teaching?**

Analysis of the interview records revealed that most participants responded with quick, short and decisive answers, indicating that they were confident that their answers were correct and did not need any deliberation whatsoever. Most of the answers given in response to these questions were single word or single phrase answers.

There were some prepared questions that assisted the educator in answering the research questions. However, during the interviews some other questions ensued, depending on how the learners answered the preceding ones. Some of the major and relevant answers to the questions are presented below in relation to the themes that emerged.

The themes that emerged during interviews of respondents are presented and analyzed. In this section, the researcher presented the emerging themes such as sadness, doubt, learners expecting more, better understanding of concepts, different expression of the concept, and the impact of real life examples on concepts taught in the class. These will be explained further.

#### 4.5.1 Sadness and Fear

When a concept is introduced to learners and it does not make sense during the teaching and learning process, the learner becomes hysterical /stressed/ anxious or sad. The first theme that was observed during the interview was sadness in learners. The interviewees below experience the same scenario.

**G2L11:** *I am sad because we were never given the chance to work on our own in physics practical's.*

**G1L14:** *The teacher always did the practical and you will just see the bulb light as if its magic.*

**G2L33:** *It is sad because when you predict what will happen and what we saw in the simulations it comes out clear now. It is making sense now.*

**G1L25:** *It was not clearer at the beginning and I just made a prediction without any insight. I can see the difference now.*



#### 4.5.2 Doubt

The second theme that emerged from the interview was doubt. When a concept is new to the learner, he/she will doubt whether to believe or reject the new information. That is evident in the response he / she gives about that concept because the concept is not yet accommodated in the learner's conceptual framework. Doubt is showed from the following responses:

**G1L31:** *When we practice we do wrong but on the third attempt we did the correct thing.*

**G2L24:** *The manner in which the observations were taken, was a flop. But we managed to do the right thing. We were not sure whether it was the right or the wrong thing.*

**G2L17:** *I was not sure what to do but through practice, I am now sure.*

Learners seemed doubtful about the concept. Moreover, the researcher observed not only doubt among the learners, because they also showed resentment whenever the concept came up - there was a lot of doubt and a lack of confidence.

### 4.5.3 Learners expecting more

The third theme that emerged was that learners expected more from the exercise. According to all learners, the way in which experiments and demonstrations done in class were the main difference. Some learners stated that they have never done science experiments because the only person who handled the apparatus was the teacher and the practical's were demonstrated in class. All learners stated that they usually take notes, but this was different, as they wrote laboratory reports which increased their knowledge preservation. The following observation were stated in their responses.

**G2L38:** *The way you presented the lesson enabled me to grasp all the information. The demonstrations and experiments we did in class improved my understanding.*

**G1L26:** *It was the first time doing experiments in class, usually the teacher talks, we just listen and take notes, but in this lesson, we participated in class and were allowed to exchange ideas.*

**G2L18:** *We were able to talk, discuss and do experiments on our own.*

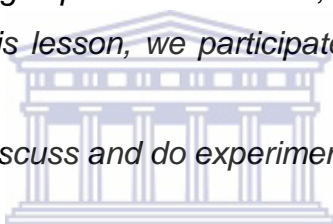

### 4.5.4 Better understanding of concepts

The fourth theme is about the learner's better understanding. A formula carries a lot of information about quantities involved. To most learners who participated in the intervention programme a formula was meaningless. Only one focus group had a satisfactory/good and deeper understanding of the formula and concept. Teaching plays a big role in supplying learners with knowledge. A learner can also be equipped by doing practical work and interacting with internet simulations. A learner is not only hands-on when doing a practical investigation or working with simulations, a learner also thinks about what he or she is doing. This learning process helps the learner to construct meaning for a better understanding of concepts.

**G1L36:** *The teaching in the classroom and practical work helped us to understand better because we were able to see what we were talking about.*

**G2L24:** *It is the practical work and interactive simulations that was interesting.*

**G2L25:** *Simulations and practical work helped us to understand the electric concepts clearly.*

In two of the three responses it is evident that learners gain more insight from what they learn from practical work and simulations, i.e. when they construct it themselves. They showed a lot of enthusiasm while they were busy with practical work.

The formulae that was used to calculate the rates and the electric consumption were new and learners used them for the first time. No one told or suggested these formulae to them. Other groups started using formulae to make predictions and suggestions on how to use electricity better.

#### **4.5.5 Different expression of the concept**

The fifth theme that emerged is: concepts expressed in different ways. Formulae help us define concepts and to do calculations that quantify those mathematical concepts. Conceptual change approach can also be used to link and visualize concepts. A perception of how concepts are expressed is given below:

**G1L13:** *I think I can take readings and do the calculations better now, and I now understand better.*

**G2L29:** *I think that one can also use graphs and show the relationship when using different materials.*

**G2L34:** *I can now use the formulae to calculate the current, potential difference and resistance. Even the resistance of the series and parallel resistors.*

A concept that tolerates difficult testing as expressed by interviewees above becomes accepted by the researcher and is added to the body of scientific knowledge.

#### **4.5.6 The impact of real life examples on concepts**

The last theme that emerged is the impact of real life examples on concepts taught in the classroom. Learners were shown different real life examples of the scientific concepts

learnt in the classroom. They were made to understand that science does not stay/remain in the classroom but forms part of our everyday life, and that science is all around us. Learners responded this way when they were given a chance to explore the real life examples:

**G1L5:** *We realized that electricity and electric circuits are in everything that we come across or use every day of our lives.*

**G2L28:** *Real life examples made concepts like in series conductors, the current is the same, and the potential difference divides, doing it practical it was more understandable.*

**G2L30:** *I feel more confident. I think I can solve any problem on the electricity and electric circuits.*

**G1L6:** *Real life examples made me realize that electricity and electric circuits forms part of our lives. Whatever we do, we need electricity now more than anything. We cannot survive without electricity. Our lives depend on it.*

The learners' responses show that using real life examples make concepts more understandable and builds confidence about the concept *being taught / learnt*. Learners realize the importance and applicability of science in the real world and that arouses their curiosity and interest to learn more about the concept.

#### **4.6. CONCLUSION**

This chapter gives an analysis of the results of the pre-test, intervention, post-test and interviews following the four conditions in the conceptual change approach. Responses from the interviews were analyzed in this chapter. The following chapter will discuss the findings and compare the results. The researcher's opinion will be discussed in the following chapter.

## CHAPTER 5

---

### DISCUSSION

---

#### 5.1 INTRODUCTION

This chapter presents the major findings of this study in agreement with the research aims. The quantitative and qualitative results of data collected using the research design and methods defined in chapter four are presented hereunder. The descriptive analysis and frequency tables were used to analyze data from the questionnaire. As a first point of departure, the biographical outline of the respondents is presented. The findings to the research aims are then presented, starting with the findings related to the identified additional conceptions about electric circuits amongst grade 10 learners. Secondly, the efficiency of the interventions developed is presented and discussed on the basis of the following research questions:

**How effective was the conceptual change approach in improving learners' understanding of electric circuits?**

- (i) **What were the learners initial understanding of electrical circuits?**
- (ii) **How was the conceptual change approach used to teach electric circuits?**
- (iii) **What were learners' understanding of electric circuits after the conceptual change lessons?**
- (iv) **What were learners' perceptions of the conceptual change approach to teaching?**

#### 5.2 Comparison between pre-test and post-test

Determining the sources of the pre-test on electric circuits was essential for this reason. The pre-test for learners might have informed the way they demonstrated the implementation of conceptual change approach in the classroom. It emerged from their responses and how they handle the practical work. These findings support those of Ates (2005) that the learning cycle approach is more effective in teaching most of the

interrelated concepts, and a number of different concepts involved in direct current electricity than the traditional approach.

The average percent of correct responses of the pre-test was 28% and that of the post-test was 70%. When the post-test scores were compared with the pre-test scores, a statistically significant difference between the mean scores of the pre-test and the post-test existed in favour of the post-test was found. The results show that there was a significant difference between the post-test mean scores of the learners compared with the pre-test mean scores, after they have been taught by Conceptual Change approach. These findings showed that learners unveiled significantly higher performance levels in the post-test than in the pre-test. The participants made substantial gains in their understanding of the electric circuits. The results of the pre-test and the post-test were analyzed and illustrated by the following table and graph:

Table 11. Comparison between pre-test and post-test.

PERCENTAGE	LEVELS	PRE-TEST	POST-TEST
$0 < x \leq 29$	1	15	1
$29 < x \leq 39$	2	15	1
$39 < x \leq 49$	3	7	4
$49 < x \leq 59$	4	2	2
$59 < X \leq 69$	5	1	9
$69 < X \leq 79$	6	0	10
$79 < X \leq 100$	7	0	13

The results in table 11 above show that before the intervention, 15 learners obtained level 1 and level 2, which in terms of percentage, is less than 39%, and 7 learners obtained level 3, which in terms of the percentage, is not more than 18%. From the table, it is evident that there were no learner's who obtained levels 6 and 7. So it is evident that the learners came to class with misconceptions with regard to electric circuits. There are many studies in the literature concerning student misconceptions about electricity and its



features. However, studies that challenge learning difficulties in electricity mainly focus on direct current circuits (Duit, 1993). The concept potential difference, for example, is one of the more difficult to learn when studying basic electric circuits (Eylon & Ganiel, 1990), keeps a direct relation with the concepts of electric field and potential difference taught in electrostatics.

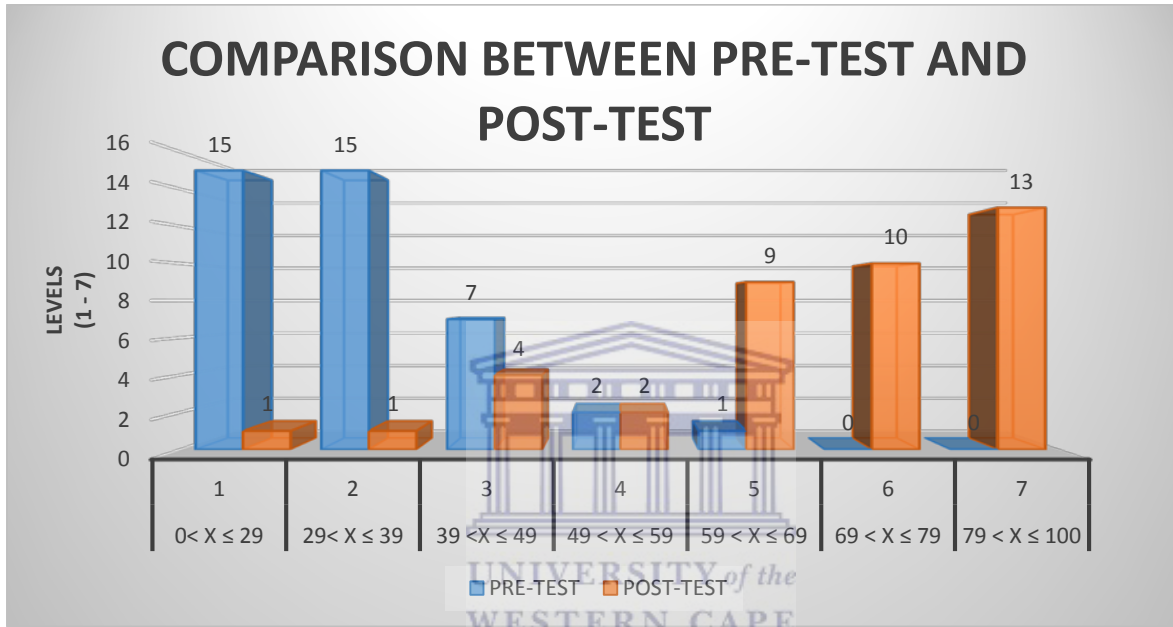

Graph 4: Comparison of pre-test and post-test.

The graph 4 above presents an indication of the number of learners who obtained different levels in a pre-test and a post-test. The graph it is indicated that from a pre-test, the percentage increases, the number of learners who obtained higher percentage decreased. In level 1 there were 15 learners in a pre-test and one in the post test, 15 learners obtained level 2 in a pre-test and only one learner obtained level 2 in a post test. These findings support some of the findings of Osborne (1983); Sebastia (1993) and Engelhardt and Beichner (2004) who are of the view that students hold alternative conceptions about some concepts in direct current electricity. This is an indication of the level of learners' previous knowledge in electric circuit was generally low prior to the intervention. There were 7 learners who obtained level 3 pre-test and four learners in post-test, this indicates that there was an improvement in learner's conceptions after the

intervention. As the levels are increasing, from level 6 and level 7, the graph shows that there were no learners who obtained those levels in a pre-test, 9, 10 and 13 learners obtained levels 5, 6 and 7 respectively in a post-test. This indicates that some learners, after the intervention, changed the conceptions they had about electric circuits. The intervention has changed most of the learner's misconceptions they had about electric circuits. When post-test scores were compared with corresponding pre-test scores, there was a substantial improvement in learners' understanding and achievement of the electric circuits.

The post-test showed portions of learners' correct responses were examined and it was found that there were differences in the portions of correct responses between the pre-test and the post-test, of which it favoured the post-test. For the post-test, learners' correct responses and misconceptions were investigated. It was found that learners held some misconceptions related to electricity and electric circuits even after the intervention. Some learners could not differentiate between current and potential difference. For example, some learners thought that current is a flow of electricity which results from the movement of the electrical charges, while potential difference is the energy released in the transfer of a unit quantity of electricity from one point to the other.

Analysis of graphs found that there was significant difference between the results of the pre- and post-test. Therefore, learners had the same understanding of the topic (simple electric circuits). The groups were on the same level academically. The analysis of learner's responses reveals the following presumptions of learner's about the selected concepts in direct current electricity: all the learners had the correct conception that the brightness of a bulb will increase giving the reason that the voltage will be doubled to supply more current.

### **5.2.1 Implementations of the study**

The significance of these findings is that although all learners passed the pre-test, that does not mean that this population of learners knew all the scientific concepts on electricity and electric circuits. There were alternative conceptions that they were still holding on to. This baseline information is necessary if the teacher is to teach science concepts by way of conceptual change. The fact that few learners obtained high percentages in the pre-test above 30% does not mean that learners had no other conceptions that they had prior to the intervention. This indicates that a learner does not come to the classroom with an empty mind. There are some scientifically correct concepts in the learner's conceptual framework that the learner knows. Nevertheless, none of the learners obtained full marks. This indicates that learners had alternative conceptions that need to be corrected in the classroom. It is the responsibility of the teacher to help the learner consciously throw away the alternative conceptions and actively learn the scientifically correct concepts. (Robottom, 2004) stated in his study that learners come to the science class with their own ideas, beliefs, and understanding of how things work, and therefore learning is not to fill the learner's head with information and data, but to change or work with their existing ideas and beliefs. Learning is seen by Robottom (2004) as conceptual change. Later on we shall see whether or not the intervention made any difference to their achievement. This total mark obtained in the overall shows limited understanding in certain electric concepts.

Learners showed an improvement during the lesson presentation. They had the right conception about the brightness of a bulb when identical cells connected in parallel, giving the reason that the brightness will remain the same since each cell will contribute half of its voltage. The first group of learners had the correct conception about the brightness of bulbs connected in series to a cell in a circuit by predicting that the brightness of the bulbs will decrease - giving the reason that the source voltage will be shared among the bulbs while the other group had no idea and reason for the occurrence. One group showed an understanding that current is not consumed by circuit resistors or bulbs in a series circuit while the other group have alternative views on the concept. Learners had the correct conception that the source voltage will be shared equally among similar resistors

connected in series in a circuit as per practical conducted while the other group had alternative conceptions about the concept.

Learners had the correct conception about the brightness of bulbs connected in parallel, predicting that the brightness will remain the same. Giving the reason that voltage across identical bulbs connected in parallel are the same, this shows that they have picked that up while they were making their observations. Ten percent (10%) of the learners had the correct scientific conception that the ammeter readings are different, the reason being that the current through ammeter A will be shared among ammeters  $A_1$ ,  $A_2$ ,  $A_3$  and  $A_4$  (i.e.  $A = A_1 + A_2 + A_3 + A_4$ ). Twenty-one percent (21%) of the learners had the correct conception about the voltage across identical resistors connected in parallel in a circuit giving the reason that the voltage across a parallel circuit is constant.

Learners showed common understanding on the identified conceptions as follows:

- The brightness of a bulb connected in series to dry cells connected in parallel circuit will increase because the voltage of the cells will increase.
- The brightness of identical bulbs connected in series circuit will decrease because the current will be shared among the bulbs.
- Learners confused and used interchangeably the concepts, current and voltage incorrectly. They misinterpret Ohms law the other way round.
- Current is consumed or used up by circuit elements such as resistors.
- Voltage is constant in a series circuit whereas it varies in parallel circuit.
- The brightness of identical bulbs connected in parallel circuit will decrease because the source voltage is shared among the bulbs in the circuit.
- The voltage is shared equally among similar resistors connected in parallel in a circuit.
- Resistance decreases the voltage in a circuit.

### **5.3 Perception (Intervention) of the study**

Based on the study learners' responses to statements on information on learning, the following can be assumed: Most learners disagree that they conduct practical experiments at school regularly. All learners disagree that they are confident in carrying out experiments on their own without the educator's assistance or guidance. Most learners agree that they can follow instructions to perform experiments but their problem is the fact that they do not know the names of the apparatus and other lab equipment. Most learners disagree that they understand the science concepts when the teacher demonstrates an experiment but they learn less as they cannot see some of the reaction. Clearly because the demonstration take place in front and on the table. Some learners were disappointed as they learnt nothing. Five learners agreed that they could use and hold apparatus when conducting experiments while seven disagreed. Most learners considered the contribution of practical work in learning science to be important because it where they learn the concept better at their own way.

Based on the learners' responses to statements on information on simple electric circuits, the following can be deduced:

- Almost all learners agreed that they like to solve problems that are based on simple electric circuits.
- The majority of learners disagreed that they could relate the work on simple electric circuits to their everyday life experiences.
- Most learners agreed that they would like to be more involved when performing experiments on electric circuits.
- Most learners agreed that the work they performed on electric circuits motivated them to pursue studies in sciences, especially electricity. The majority of learners agreed that the experiments on simple electric circuit developed their skills and confidence in handling apparatus.
- Learners agreed that the study of simple electric circuits develop their understanding and knowledge of science concepts. The majority of learners agreed that the tasks based on simple electric circuits helped them to analyze problems.

- Almost all learners agreed that electric circuits gave them the opportunity to learn by doing experiments on their own and acquire knowledge through play.
- Most learners agreed that the experiments involving simple electric circuits required understanding and perseverance.
- Most learners agreed that the study of electric circuits helped them to learn how to be creative and to find answers to problems on their own.
- Almost all learners agreed that they enjoy lessons based on simple electric circuits as this type of learning is more practical.
- All learners believed that studying and doing more experiments on electric circuits are important and very interesting.
- Almost all learners disagreed that they were forced to study electric circuits.

Based on group learners' responses to statements on information on Conceptual Change Model, the following can be deduced:

- Almost all learners agreed that they understood science concepts better and have better understanding of Ohms law.
- All learners agreed that the atmosphere during lessons inspired their thinking.
- Most learners agreed that lesson presentation on electric circuit was clear and inspired them.
- Most learners agreed that they have learnt new things (concepts). Most learners reached a decision that they had learned how to investigate and follow a scientific investigation in science.
- The majority of learners agreed that they could easily and effectively work together with their peers.
- Most learners agreed that they developed a positive attitude towards Physical Sciences.
- Most learners agreed that they previously had problems and lacked confidence to carry out experiments on their own.
- Most learners agreed that lessons on electric circuit awakened their interest and enthusiasm.

- All learners agreed that attending the session on conceptual change approach was worthwhile.
- Most learners agreed that electric circuit may develop their conducting skills.
- Most learners agreed that the practical investigations in electric circuits relate to their everyday experiences and that they would be able to handle everyday duties at home.
- Almost all learners believed that it is important to carry out more experiments on electric circuits and other science content.
- Almost all learners believed that investigations on electric circuits give them the opportunity to challenge their misconceptions.
- All learners disagreed that they will never conduct investigations on electric circuits again.
- All of them showed a lot of commitment towards their work and were enthusiastic to learn and experiment more.

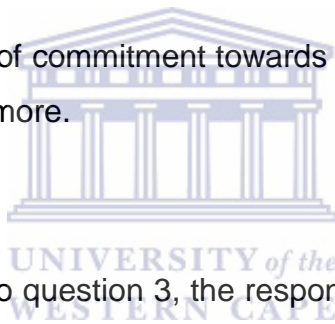

#### **5.4 INTERVIEW RESULTS**

Analysis of clarifications given to question 3, the respondents were tested to establish if they have mastered the purpose of a switch (open and closed) in the circuit. These learners had observed that the switch is open, therefore there was no current flowing through bulb  $A_3$  in series connection. However, they failed to comprehend that the remaining bulbs made a series connection. A few learners had wrong explanations about an open switch. These learners might have had a language problem as a result of everyday language (Küçüközer and Kocakulah, 2007).

Analysis of explanations given to question 4, the question intended to ascertain whether learners could easily and correctly construct a simple electric circuit, consisting of a battery, ammeter, voltmeter and resistor. During treatment phase learners made to construct many different circuits, such as the circuit from a torch, wiring a two-roomed house made from hardboard, drawing a circuit diagram when a real circuit was given, and constructing a circuit when a circuit diagram is given. The question gave respondents



opportunities to show their skill of gathering and build a circuit. Most learners were able to construct correct scientifically acceptable models. However, other learners (15%) still confuse the connection of ammeter and voltmeter and how to make a correct connection of measuring current and potential difference using instrument (multi meter). These learners lacked hands-on activities. One may construe that these learners might have been not given enough chance of handling apparatus as expected by the conceptual change approach.

The aim of analyzing this section was to evaluate the impact made by the Conceptual Change Approach Model in learning science concepts, particularly those concepts related to the simple electric circuits. The results indicated that the responses given were appropriate. These were questions in which most learners demonstrated deep embedded misconceptions. Some of the misconceptions found in the literature were in line with those that were reported in the findings section of this study. A summary of such misconceptions is given below.

The following were the misconceptions that were discovered during the research study:

- \* Increase in the number of cells always increases the potential difference (question 1). The same finding was reported by Lee and Law (2001).
- \* Sequential reasoning: A change before the bulb in a series circuit affects the bulb's brightness but some changes after the same bulb does not affect the brightness of the bulb. This misconception was also reported in the studies by McDermott and Shaffer (1992).
- \* Consumption of current: Current is consumed its circuit electrical components (such as bulbs, resistors, etc.), therefore the current diminishes when it returns to the battery. Such misconception was also reported by Baser and Durmus (2010), Alebious (2005) and Lee and Law (2001).

Batteries are constant current source. The same misconception was encountered in the study of Küçüközer & Kocakulah (2007).

Some learners still had problems of using ammeter and voltmeter correctly. When on how they connect and the instrument reflect negative, it was further revealed that the findings



of this study shown similarities with other studies (Wesi, 2003; Engelhart and Beichner, 2004; Lee and Law 2001; Borges and Gilbert, 1999) in that learners used the concepts of voltage, current and energy interchangeably as if these concepts are the same.

### **5.5 Additional aspects of the study**

Findings of the study were in agreement with these of Chambers and Andre (1997), who used a text-based conceptual change approach in electricity concept. They investigated relationship between gender, interest and experience in electricity, and conceptual change manipulations on learning fundamental direct current concepts. They concluded that conceptual change text approach leads to better conceptual understanding of concepts than traditional didactic text. In this study, conceptual change text instruction promoted the acquisition of new conceptions as a consequence of the exchange and differentiation of the existing conception and integration of new conceptions with existing conceptions.

The findings of the study were in agreement with these of Yalvaç (2000), who investigated 6th grade level students' understanding of electricity concept by designing conceptual change text using analogies and trying to evaluate this teaching strategy. According to the results of data analysis he concluded that the students instructed with conceptual change texts had a better understanding than the students taught with traditionally designed physics instruction.

In traditionally designed physics instruction was based on the teacher explanations of scientific phenomena, logical presentation of knowledge and some quantitative examples given in the textbooks. Learners' previous ideas and misconceptions related to the electric field, electric potential and electric potential energy were not considered in this instruction. As a result, this situation may become a reason why learners who were instructed with conceptual change texts had fewer misconceptions than the students who were instructed with traditional designed method. The traditional instruction has little impact on removing deeply rooted misconceptions (Brown & Clement, 1987).

As a result, it was confirmed that conceptual change text design lead to a better conceptual understanding of electric field, electric potential and electric potential energy concepts. Conceptual change texts used in this study were designed to make the learners come face to face with their probable misconceptions and to replace these probable misconceptions with scientific explanations of related concepts. They helped learners to consider their prior knowledge and produce dissatisfaction, provide a correct understandable explanation, which is plausible for them. As it was mentioned before, the data in this study shows no significant difference in improving attitude towards physics. Some probable causes might be identified. Firstly, the electricity unit is taught at grade 10 after the unit of mechanics, and is by far more abstract topic. Therefore, this abstract nature of the electricity unit might prevent the learners from achieving more positive attitudes toward physics. Moreover, the learners were taught with conceptual change text instruction for only three weeks, which may not have been a long enough time period to show a difference in attitude of learners between the two teaching methods. As a result, whatever the cause of the lack of difference in attitude toward physics, this study support that conceptual change text instruction is effective on overcoming the learners' misconceptions.



## **5.6 Discussion of the Results**

According to conditions the conceptual change texts asked questions to activate prior knowledge. It helped learners consider the pre-existing ideas and created a conflict between the learners' misconceptions and scientific knowledge by demonstrating inconsistencies between them. This conflict caused learners to be dissatisfied, this dissatisfaction enabled conceptual change text to restructure the compatible knowledge of learners and realize their misconceptions. In addition, the dissatisfaction also opened the way for the conceptual change text to explain why some of the learners' ideas are not true and why scientific ones are true by giving examples and evidences within its content.

The conceptual texts helped the individual to grasp how experience or questions asked in first part can be structured by a new conception. By the help of the conceptual texts a new concept appears initially plausible and at least had the capacity to solve the problems

generated by its predecessors. Designed texts had the potential to be extended and open up new areas of inquiry and explanatory power.

Misconceptions often reflect a basic lack of understanding; therefore, when teaching physics concepts, the teacher should focus on these misconceptions and make the scientific concepts as concrete as possible. It is not enough for learners to become aware of their existing ideas but they should also change their incorrect conceptions by interacting with teachers and peers. For this purpose, the present study used conceptual change texts based on Posner et al.'s (1982) conceptual change model which suggests that four conditions are necessary for an accommodation occur in an individual's understanding.

## **5.7 Conclusion**

In this study, learners' conceptions of electricity and electric circuits were examined. While the majority of the learners seemed to have made some progress in their conceptual development as a result of their exposure to conceptual change, others struggled with the approach. This finding corroborates earlier findings that conceptual change approach succeeded in changing learners' perception and attitude towards the study of electric circuits; hence they were able to relate the work on electric circuit with their daily experiences. The teaching of electric circuits should give learners the opportunity to make a wider choice of moulding their future in the field of work. Electric circuit concepts are not only useful to their future studies but also have relevance to their present everyday experiences. If science is to be more acceptable and worthy of its salt, it needs to be given cognisance. Learners need to be made aware that science is not just a classroom subject prescribed in the syllabus but a human enterprise with practical implications for their daily life experiences. This needs to be encouraged not only by the teachers but be reflected in science textbooks, the curriculum as well as the examinations. Science teachers should examine their conceptions of how learners learn and what teaching methods can best facilitate learning. This will not only improve learners' conceptual understanding of electricity and electric circuits but their performance in science in general.

The next chapter presents the conclusions and recommendations.



## CHAPTER 6

---

### SUMMARY AND CONCLUSION

---

#### 6.1 INTRODUCTION

In Chapter 1, the questions relating to this study were raised. In Chapter 2, the theoretical framework in which the study was situated was discussed in detail, while Chapter 3 described the methodology used in collecting the data. In chapter 4 the results based on the quantitative and qualitative data are analyzed and discussed. Chapter 5 summarizes the major findings and scrutinizes the implications of such findings for effective teaching of electric circuits. Finally, the chapter offers some summary and conclusion with further suggestions for the research study.

#### 6.2 OVERVIEW OF THE STUDY

##### Chapter 1

The motivation for the study, problem statement, outline of research topic, research objectives. Introduction to background and context of the study on national, provincial, district and school level. Educators' attempts to establish what conceptual change is and what it means for science education in particular. National reports highlight that learners' achievement has been poor especially in the Eastern Cape. Table 1 reflects the results for physical sciences over the past five years. Table 2 presents a history of pass percentages. An analysis showed that learners have difficulties in answering questions relating to practical work particularly when it comes to electricity and magnetism.

Grade 10 is the entry class for the further education and training (FET) phase and if the learners get their basic science education at this level it will influence their understanding as they progress to higher classes, adding new concepts to what they already know.

South Africa performs poorly when compared to the international situation. Critical factors that affect educational outcomes are in-classroom factors, are such as educators, teaching and resources. In-school factors, are such as leadership and management and

out-of-school factors, are such as parental involvement, outside disruptions and socio-economic circumstances.

The study aims to show how conceptual change as a teaching strategy can serve to improve the teaching of science concepts and to develop the learners' ability to link what they learn in class with the outside world.

## Chapter 2

The study's theoretical framework is underpinned by the conceptual change approach. According to Posner et.al. (1982), in order to achieve Conceptual Change, the new conception must be intelligible. The learner must know what the new conception means and easily understand the conception. Therefore, Conceptual Change Texts were prepared so that every learner can easily understand and comprehend what was written. In addition, in order to make content concrete and enhance remediation of misconceptions, demonstrations, experiments, videos, examples and detailed diagrams were used. In other words, activities that involved presenting and developing ideas helped learners to practice and strengthen the conceptual understanding. This also satisfies plausibility stage, the third condition mentioned by Posner et al. (1982) where the new conception must appear plausible in order for conceptual change to take place.

The learner must believe that this new conception is reasonable and it is consistent with their world view. Some daily life examples were given to show that the electricity and electric circuits concept is very important for understanding the nature. Learners can then find some value for learning the new concept, thus satisfying fruitfulness, which is the last condition presented by Posner et. al. (1982) for obtaining conceptual change. Therefore, it is evident that identification of misconceptions and cognitive conflict were very important in conceptual change approach.

The prior knowledge that learners have affects their further learning. These prior conceptions can hinder construction of new knowledge. According to information processing theories, individuals construct knowledge by forming connections between newly organized knowledge and existing relevant knowledge and therefore, if prior

knowledge is dissonant with the new information, meaningful learning cannot occur. Prior knowledge is the most influential predictor of science achievement (Gooding et al., 1990; Lawson, 1983) and the degree to which prior knowledge is consistent with the new subject matter is an indicator of the improved science learning. Therefore, teaching for understanding requires identification of misconceptions. As a summary of the findings from the study, one can say that conceptual change texts are very efficient in diagnosing and overcoming learners' misconception problem. Conceptual change strategies have a direct and positive influence on learners' academic success and creativity. Hence, they should be applied to classes more often.

### Chapter 3

The research method used is the semi-structured interview in order to obtain a superior depth of information. A pilot study was conducted during the third term of 2015, to determine whether the instrument is viable. Mixed research means research that involves the mixing of quantitative and qualitative methods or paradigm characteristics. A case study was used because it was based on specific grade in the same school. One class was purposefully selected for the study. The same class that was taught by the researcher. Learners were given a pre-test to check the level of understanding of electric circuit context. They were not informed that they were going to write a test. The pre-test formed a baseline assessment of the research study.

Data was gathered in the form of field notes triangulation was used in research methodology. Sampling techniques used were purposive random selection and simple random selection. The learners were allowed to link all the information to their own experiences and within their cultural background. The data collection process followed four steps as identified in Table 5 of the methodological framework below. A post-test was followed by semi-structured interviews and a comparison was drawn from the pre-test and post-test and the manner in which the results were analyzed using Excel program.

Chapter 4 is an analysis of the results of the pre-test, intervention, post-test and interviews. This chapter reports on the results obtained and is organized around the data

collected to answer the research question. In order to improve effective learner understanding in electric circuits, a conceptual change approach was used.

The results of the learners' marks were recorded and a question-by-question analysis was done. From the results obtained by the learners the average percentage was 28%, as tabulated in Table 7.

Graph 1 shows the average mark percentages obtained by each learner. The achievement in Question 1 was 50%. In Question 2 the test showed that most learners did not understand the concept. In Question 3 only a few learners (17 %) showed an understanding. In Question 4 learners obtained 33%.

In Questions 5 - 8 learners obtained 25%. In Question 9, 40% was achieved showing that most learners knew what the symbol represented in a simple circuit diagram. Question 10 reached 23%. The lesson contained inquiry questions with learners' responses. The questions were asked during the first stage of the lesson to activate learners' existing knowledge about electricity and electric circuits.

The second session of the concept of electricity is concerned with electric circuits. The educator assessed learners' conceptions by asking questions and allowing them to respond. They were allowed to use their textbooks and discuss their responses as a group. That concluded the first step in the conceptual change model, namely dissatisfaction with their initial understanding as indicated by Posner et al. (1982).

Learners wrote a post-test after they completed the experiment and the class activity. The results showed an improvement compared to the pre-test. In two of the three responses it is evident that learners gain more insight from what they learn from practical work and simulations, i.e. when they construct it themselves. They showed a lot of enthusiasm while they were busy with practical work. Learners realized the importance and applicability of science in the real world and that arouses their curiosity and interest to learn more about the concept.



## Chapter 5

This chapter presents the discussion of the findings of the study and includes learners' responses to statements on information on simple electric circuits. Interview results showed misconceptions related to electricity and the way concepts were sometimes confused and used incorrectly, e.g. learners using the concepts of voltage, current and energy interchangeably as if these concepts are the same. The conceptual change approach helped learners consider their pre-existing ideas on electric circuit and opened the way for the required "dissatisfaction" that enables the conceptual change text to restructure the compatible knowledge of learners and realize their misconceptions (e.g. sequential reasoning and consumption of current). A summary of such misconceptions is given.

The quantitative and qualitative results of data collected and a comparison between pre-test and post-test results is made and analyzed and illustrated in Table/Figure 9. On the basis of these findings recommendations for further research is given, such as sample size, geographical setting, a greater range of science topics and various instructional methods, e.g. understanding through visualization and interacting with teachers and peers. Conceptual change texts have the potential to be extended and open up new areas of inquiry and explanatory power. This way of teaching electric circuits by conceptual change instruction is effective in improving positive attitudes toward physics. It also gives learners the opportunity to make a wider choice of future careers.

### 6.3 Major findings

There was more effective learning in learners not only on electricity but on the other interrelated concepts better than traditional approach. There was a significant improvement in content knowledge showed by the assessment during the pre- and the post – test using Conceptual Change Approach. A substantial gain in understanding of electric circuit was experienced. The intervention managed to clear some of the misconceptions that the learners had in regard to electric circuits, electricity and its features. It also increases the learner's conceptions in regard to the electric concept before and after the intervention. This was shown by the increase in the levels of

understanding of the learners after the intervention. However, there were still learners who clung to their own perceptions and understanding of the concepts taught.

#### **6.4 IMPLICATIONS OF THIS STUDY**

The study is based on the effective teaching of electric circuit using conceptual change approach. The method used here has four different stages of learners' cognitive knowledge and also identified learners' misconceptions. The four stages of conceptual change also form part in addressing the learning channels. Each stage addresses a certain level in the understanding of the learner. The misconceptions are identified and they need to be address in the manner at which the child will be able to come to terms on his/her own way. Learner must be able to come up with his/her own solutions to each and every problem they came across. The teacher is only there to guide and assist learners to come to understanding at their own time and pace. Learners must find the solutions and answers to all their misconceptions on their own. By so doing they grasp the correct meaning of the concept, and they were able to know and relate that meaning in their day-to-day leaving. With this experience, learners are able to narrate the concept and are able to explain it to their peers.

Instruments used were based on the four stages of conceptual change approach where the first step has to address the learners' dissatisfaction. To address dissatisfaction on learners', we needed to figure out their misconceptions by giving them post-test. The pre-test determined the baseline understanding of the learners' level of understanding. The intervention plan was done in order to address the learners' misconceptions. The second stage of conceptual change was to conduct lesson that was gave clarity on the misconceptions. In addition to that a practical investigation was conducted so that the learners may experience what they were taught in class and make meaning of it. The third stage is plausibility, learners were able make meaning of each and every misconception they have previously. The last stage of conceptual change is fruitfulness. The instrument that was designed to address this stage was a post-test that was similar to the pre-test.

The intervention in my study was relevant and was important because, after the baseline assessment, it gave a clear understanding of how much the learner understood the concept. What are the learners' misconception? How best can you address their misconceptions? These misconceptions gave you an idea on how to plan and prepare the relevant instruments that would be the best to address it. The conceptual change approach addressed more learner's dissatisfaction and they needed sort and come to a clearer understanding of the concept. The intervention assisted the researcher to reach the goals and to address the research question and to the satisfaction of learners, as well as learning process. The study was helpful to learners, educators, stakeholders and other researchers.

The study showed interest to learners as their interaction changed from what it was before they were involved in the programme. They were always happy and they were the ones who probed more questions and needed clarity on different fields. They have learnt a lot in the content itself. They were not afraid to handle apparatus, they handled the devices and they corrected each other when one made mistake. The other educators also applauded the manner in which this group behaved. They are now sharp and they are the ones who ask educators a lot of questions. The educators now need to be more prepared for them than ever. They are now more open and are not scared of challenges. They built confidence to speak in English or their own mother tongue as long as they have voiced out what they needed clarity on. The stakeholders are motivated to see such enthusiasm in the learners and they are willing to work with them and sponsor the school.

## **6.5 LIMITATIONS**

The study focused on one school in one district which have limited the results. A few schools could give more diverse answers in terms of observation and results. The sample size also is less as it is in a small school. Schools with large numbers and as well as different schools can also be used. The fact that it was used by one educator different educators can be used to implement the same instruments. A pilot test was only used in

a small scale, a larger scale can be used to check the effectiveness and relevancy. The different level of academic of learners can also be changed and monitored using the tool. Different area can also be used like rural and urban community and monitor the different situations. The implementation of the research for the first time could also have its own limitations. Second experience could have different impact on the results. The language efficiency of learners in a specific area can also be ventured. The study is conducted in English and learners are expected to respond and cooperate in all aspects in English. Some of learners do not respond due to the fact that they have to respond in English. This could be a limiting fact and that might contribute in the results gather in the study. The learners content background is influenced by the misconceptions and the exposure to different environments. Content background of learners is not the same, this could also be a limiting factor.

## 6.6 RECOMMENDATIONS FOR FUTURE RESEARCH

The following recommendations have been made for educational practice:

1. In teaching concepts in direct current electricity, can also be expanded to the whole district and used as a tool to improve science results.
2. The conceptual change approach could be used effectively by the teachers as it will assist them to iron out the misconception learners have prior the learning.
3. Teachers should try to learn and use the learning cycle approach in their instructions as much as possible since it exposes learners' correct and alternative conception about concepts in science prior to instruction.
4. The learning cycle approach helps learners to develop scientific concepts adequately with limited teacher guidance.
5. Further research needs to be conducted to identify the shortcomings or limitations of conceptual change approach.
6. It is suggested that in-service training should be organized for physics teachers to train them on how to use conceptual change approach effectively.

## 6.7 CONCLUSION

Learners taught with conceptual change approach showed a better scientific conception related to electric circuits and electric potential and elimination of misconceptions. Conceptual change approach was effective in improving positive attitudes toward electricity in particular and to physical sciences in general.



## REFERENCES

1. Ates. S., 2005. The effects of learning cycle on college students understanding of different aspects in resistive DC circuits. *Research in Science & Technological Education*, 2005 – Taylor & Francis
2. Alebious. K.A., (2005). *“Utilising selected informal science experiences to teach science in inquiry-centred Nigerian classrooms.”* *Africa Education Review*, 2005 – journals.co.za
3. Ausubel, D. P. (1968). *Educational psychology: a cognitive view*. New York : Holt, Rinehart and Winston.
4. Babbie, E. & Mouton, J. (2001). *The practice of social research*. Cape Town: Oxford University Press.
5. Baser, M. 2006. Promoting conceptual change through active learning using open source software for physics simulations. *Abant Izzet Baysal University, Turkey Australasian Journal of Educational Technology*, 2006, 22(3)
6. Başer, M. ve Geban, Ö. (2007). Effectiveness of conceptual change instruction on understanding of heat and temperature concepts. *Research in Science and Technological Education*, 25(1),115-133.
7. Baser, M; Durmus, S. (2010). *“The Effectiveness of Computer Supported Versus Real Laboratory Inquiry Learning Environments on the Understanding of Direct Current Electricity.”* *Eurasia Journal of Mathematics, Science & Technology Education*, 6(1), 47-61
8. Berkowitz, D., Wolkowitz, B., Fitch, R. & Kopriva, R. (2000). *The use of tests as part of high-stakes decision-making for students: a resource guide for educators and policy makers*. Washington, DC: US Department for Education.
9. Bergquist, W. & Heikkinen, H. (1990). Student ideas regarding chemical equilibrium: What written test answers do not reveal. *Journal of Chemical Education*, 67(12), 1000-1003.

10. Bodner, G. M. (1986). Constructivism: A theory of knowledge. *Journal of Chemical Education*, 63, 873-878.
11. Borges, A. T. & Gilbert, J. K. (1999). Mental models of electricity. *International Journal of Science Education*, 21(1), 95-117.
12. Brown, D.E.; Clement, J. (1987). Misconceptions concerning Newtons' Law of action and reaction: The underestimated importance of the third Law. Proceedings of the Second International Seminar. Misconceptions and Educational Strategies in Science and Mathematics. Physics Department. University of Massachusetts. Amherst, Massachusetts. July 25 1987.
13. Bulmer, M.; Warwick, D.P. (1993). *Social Research in Developing Countries: Survey and Censuses in the Third World*. Routledge. London. Taylor and Francis Group
14. Caine, R.N. & Caine, G. 1994. Making connections – teaching and the human brain [Kindle ed.]. Available: <http://www.cainelearning.com>
15. Chambers, S.K., & Andre, T. (1997). Gender Prior Knowledge, Interest and Experiences in Electricity and Conceptual Change Texts Manipulations in Learning About Direct Current. *Journal of Research in Science Teaching*, 34, 107-123.
16. Chang, K-E., Chen, Y-L., Lin, H-Y., & Sung, Y-T. (2008). Effects of learning support in simulation-based physics learning. *Computers and Education*, 51(4), 1486–1498.
17. Chi, M.T.H., Slotta, J.D. & De Leeuw, N. (1994). From things to processes: A theory of conceptual change for learning science concepts. *Learning and Instruction*, 4, 27-43.
18. Chisholm L & Chilisa B (2012). *Contexts of educational policy change in Botswana and South Africa*. Article · December 2012. DOI: 10.1007/s11125-012-9247-5.
19. Cohen, L., Manion, L. & Morrison, K. 2011. *Research method in education* (seventh edition), Routledge, London & New York. Consequences



- for Teaching. *Science Education*, 66, 623-633. Constructivist Analysis of Knowledge in Transition. *The Journal of the Learning*
20. Creswell, J.J. (1998). *Qualitative inquiry and research design: Choosing among five traditions*. Thousand Oaks: Sage Publications Inc.
  21. Creswell, J. (2003). *Research design: Qualitative, quantitative and mixed methods approaches*. Thousand Oaks: SAGE Publications.
  22. Creswell, J. W. (2008). *Educational research: Planning, conducting, and evaluating quantitative and qualitative research*.
  23. Creswell, J. W., (2009). *Research design: qualitative, quantitative, and mixed methods approaches*. Los Angeles: Sage.
  24. David M, Sutton, C.D. (2004). *Social Research: The Basics*. SAGE Publications. London. Thousand Oaks. New Delhi.
  25. Dega, B.K. (2012). *Conceptual Change through Cognitive Perturbation using Simulations in Electricity and Magnetism: A Case Study in Ambo University, Ethiopia*. Doctor of Philosophy in Mathematics, Science and Technology Education in the subject Physics Education at the University of South Africa
  26. Dekkers, P. (2005). African Journal of Research in Mathematics, Science and Technology Education - The Nature of Science - do teachers have the understandings they are expected to teach? *African Journal of Research in Mathematics, Science and Technology Education, Volume 7, Issue 1*, Jan 2003, p. 21 – 34. Taylor & Francis
  27. Denzin, N. K., & Lincoln, Y. S. (2005). Introduction: The discipline and practice of qualitative research. In N. K. Denzin & Y. S. Lincoln (Eds.), *The Sage handbook of qualitative research* (3rd ed.). Thousand Oaks, CA: Sage. 1-28).
  28. Department of Basic Education and Training, National Curriculum Statement Grade 10 – 12. FET Physical Sciences. 2003. Department of Education. ISBN-
  29. Department of Education. (2012). *Regulations Pertaining to the National Curriculum Statements Grades R - 12*. Published as Government



Notice 1114 in Government Gazette No. 36041 of 28 December 2012. Department of Basic Education Pretoria: Government Printer. <http://www.education.gov.za>

30. Duffy, T.M., & Jonassen, D.H. (1991). Constructivism: New implications for instructional technology? *Educational Technology*, 31, 7-12.

31. Duit, R. (2002). Conceptual change - still a powerful frame for improving science teaching and learning? Paper presented at the *Third European Symposium on Conceptual Change, 26-28 June, Turku, Finland*. [verified 24 July 2006; 2.3 MB] <http://www.edu.utu.fi/konf/Proceedings.pdf>

32. Duit, R. (2009). *STCSE – Bibliography: Students’ and teachers’ conceptions and science education*. Kiel, Germany: IPN – Leibniz Institute for Science Education (<http://www.ipn.uni-kiel.de/aktuell/stcse/stcse.html>).

33. Education in South Africa: Where did it go wrong. Retrieved from SANGONeT. [www.sangonetpulse.org.za](http://www.sangonetpulse.org.za) Wednesday, 11 September, 2013 – 10:31

34. Engelhardt, P.V.; Beichner, R.J. (2004). “Students’ understanding of direct current resistive electrical circuits. *American Journal of Physics* 72, 98(2004); <https://doi.org/10.1119/1.1614813>

35. Engelhardt, P.; Gray, K. and Rebello, N. “How many students does it take before we see the light?” *Phys. Teach.* 42, 216–221 (April 2004). <https://doi.org/PHTEAH>

36. Frankfort-Nachmias, C., & Leon-Guerrero, A. (1997). *Social statistics for a diverse society*. Thousand Oaks, CA: Pine Forge.

37. Gilbert J.K. (2005) Visualization: A Metacognitive Skill in Science and Science Education. In: Gilbert J.K. (eds) *Visualization in Science Education. Models and Modeling in Science Education*, vol 1. Springer, Dordrecht

38. Gooding, C. T., Swift, J. N., Schell, R. E., Swift, P. R., & McCroskery, J. H. (1990). A causal analysis relating previous achievement, attitudes, discourse, and intervention to achievement in biology and chemistry. *Journal of Research in Science Teaching*, 27(8), 789-801.

39. Gorsky, P. & Finegold, M. (1992). Using computer simulations to restructure students' conceptions of force. *Journal of Computers in Mathematics and Science Teaching* 11: 163–178.
40. Guzetti, B.J., Snyder, T.E., Glass, G.V., & Gamas, W.S. (1993). Promoting conceptual change in science. *Reading Research Quarterly*, 28, 117-159.
41. Hancock B. (1998). Trent Focus for Research and Development in Primary Health
42. Harrison, A.G. & Treagust, D. F. (2006). Teaching and learning with analogies: Friend or Foe? In P. J. Aubusson, A. G Harrison and S. M. Ritchie (Eds.), *Metaphor and analogy in science education*. (pp. 11-24). Dordrecht, The Netherlands: Springer.
43. Hewson, P. W. (1981). A conceptual change approach to learning science. *European Journal of Science Education*, 3(4), 383-96.
44. Hewson, M.G. & Hewson, P.W. (1983). The effect of instruction using students' prior knowledge and conceptual change strategies on science learning. *Journal of Research in Science Teaching*, 20(8), 731-743.
45. Hewson, P.W., & Hewson, M.G. (1992). *The Status of Students' Conceptions*.
46. Hitchcock. G., David H. (1989). *Research and the teacher*. Routledge, 1989. University of Michigan. Digitized, Oct 26, 2009. ISBN, 0415024323, 9780415024327.
47. Hirça N. (2011) Impact of problem-based learning to students and teachers. Harran University, Faculty of Education, Sanliurfa, TURKEY. *Asia-Pacific Forum on Science Learning and Teaching*, Volume 12, Issue 1, Article 7, p.2 (Jun., 2011)
48. Honebein, P. (1996). Seven goals for the design of constructivist learning environments. In B. Wilson, *Constructivist learning environments* New Jersey: Educational Technology Publications. (pp. 17-24).

49. Kucukozer, H.; Demirci, N. (2008). Pre-Service and In-Service Physics Teachers' Ideas about Simple Electric Circuits. *EURASIA Journal of Mathematics, Science & Technology Education*, v4 n3 p303-311 2008.
50. Hyde, A.A. and Bizar, M. (1989). Thinking in Context: Teaching Cognitive Process in Learning Physics. *Science Education*, 76 (6), 615-652.
51. İpek, H.; Çalık, M. (2007). Combining Different Conceptual Change Methods within Four-Step Constructivist Teaching Model: A Sample Teaching of Series and Parallel Circuits. *International Journal of Environmental & Science Education* Vol. 3, No. 3, July 2008, 143-153
52. Ishii, D.K. (2003). Constructivist view of learning in science and mathematics. ERIC Clearinghouse for Science Mathematics and Environmental Education (ED482722), 1-8.
53. Jaakkola, T., & Nurmi, S. (2008). Fostering elementary school students' understanding of simple electricity by combining simulation and laboratory activities. *Journal of Computer Assisted Learning*, 24, 271-283. doi:10.1111/j.1365-2729.2007.00259.
54. Johannes, E.A. (2005). Using collaborative action research to improve classroom discipline: An action research study at a secondary school in the Boland.
55. Johnson, R.B. and Onwuegbuzi A.J. (2004). Mixed Methods Research: A Research Paradigm Whose Time Has Come Educational Researcher, Vol. 33, No. 7 (Oct., 2004), pp. 14-26. American Educational Research Association. <http://www.jstor.org/stable/3700093>
56. Joseph, A. (2011). Grade 12 learners' conceptual understanding of chemical representations.
57. Jordan, B. (1992). Improving a playcentre science programme through action research. *Research in Science Education*. December 1992, Volume 22, Issue 1, pp 240–247 <https://doi.org/10.1007/BF02356901>. Kluwer Academic Publishers
58. Julie, C., Angelis, D. & Davis, Z. (Eds.). (1993). Political Dimensions of Mathematics Education 2: PMDE: Curriculum reconstruction for society in

transition: Proceedings of the Second International Conference. Cape Town: Maskew Miller Longman.

59. Karakuyu, Y. ve Tüysüz, C. (2011). Misconceptions in Electricity and Conceptual Change Strategy. *Gaziantep Üniversitesi Sosyal Bilimler Dergisi*, 10(2), 867-890.

60. Kim, B. (2001). Social constructivism. In M. Orey (Ed.), *Emerging perspectives on learning, and technology*. Retrieved 25 January, 2012, from <http://www.coe.uga.edu/epltt/SocialConstructivism.htm>.

61. Kingir, S. (2011). Using the science writing heuristic approach to promote student understanding in chemical changes and mixtures.

62. Keig, L. (1990). Formative Peer Review of Teaching: Attitudes of Faculty at Liberal Arts Colleges Toward Colleague Assessment. *Journal of Personnel Evaluation in Education*, Volume 14, Issue 1, pp 67–87

63. Kesamang, M.E.E. (2002). The Correlates of the Socio-cultural Background of Botswana Junior Secondary School Students with Their Attitudes Towards and Achievements in Science. *International Journal of Science Education*, 24 (9): 919-940.

64. Kundi, G.M. & Nawaz, A. (2010). From objectivism to social constructivism: The impacts of information and communication technologies (ICTs) on higher education. *Journal of Science and Technology Education Research*, 1(2), 30-36.

65. Küçüközer, H. & Demirci, N. (2005). High School Physics Teachers' Forms of Thought about Simple Electric Circuits. 23th International Physics Congress, Muğla University 13-16 September.

66. Kucukozer, H., Kocakulah, S. (2007). Secondary school students' misconceptions about simple electric circuits. *Journal of Turkish Science Education; Trabzon*. Volume 4 Issue 1. (May. 2007):101-115

67. Kvale, S. 1996. *Interviews: An Introduction to Qualitative Research Interviewing*. London: Sage Publications Thousand Oaks.

68. Lawson, A. E. (1983). Predicting science achievement: The role of developmental level, disembedding ability, mental capacity, prior knowledge, and beliefs. *Journal of Research in Science Teaching*, 20(2), 117-129.
69. Lee, Y., Law, N. (2001). Explorations in promoting conceptual change in electrical concepts via ontological category shift. *International Journal of Science Education*, 23 (2), 111-149.
70. Lemmer, M.; Edwards, J.M. (2007). Evaluation of natural sciences textbooks. Paper presented at the *SAIP conference*, WITS University, Johannesburg, 2- 5 July.
71. Makgato, M. and Mji, A. (2006). Factors associated with high school learners' poor performance: a spotlight on mathematics and physical science. *South African Journal of Education* Copyright © 2006 EASA Vol 26(2)253-266
72. McDermott, L. C., & Shaffer, P. S. (1992). Research as a guide for curriculum development: An example from introductory electricity. Part I: Investigation of student understanding. *American Journal of Physics*, 60, 994-1003. doi:/10.1119/1.17003
73. McDermott L.C. (1990). *Physics by Inquiry: An Introduction to the Physical Sciences*. John Wiley & Sons, New York, NY.
74. Merriam, S. B. (1988). *Case study research in education: A qualitative approach*. The Jossey-Bass education series, The Jossey-Bass higher education series and The Jossey-Bass social and behavioral science series. San Francisco: Jossey-Bass.
75. Meyer, C. H. (2014). The effectiveness of applying Conceptual Development teaching strategies to Newton's second law of motion.
76. Mintzes, J. J., Wandersee, J. H., & Novak, J. D. (1998). Teaching science for understanding: A human constructivist view. Academic Press.
77. Mistades, 2009 Mistades, V.M. (2009). Concept mapping in Introductory Physics. *Journal of Education and Human Development*, 3(1), 177-185.

78. Mkonto, P. N. (2010). The development and evaluation of a learning styles assessment tool for the South African higher education context.
79. Morgan, D.L. (1996). Focus groups as qualitative research. Qualitative research methods series 16. Second edition. A Sage University paper
80. Mpofo, E. (2006). Theories and Techniques for Counsellors Applied to African Settings. Zimbabwe: College Press Publishers.
81. Muijs D. (). Doing Quantitative Research in Education with SPSS. Second edition. SAGE Los Angeles. London New Delhi
82. Muwanga-Zake, J. W. F. 1998. Research portfolio submitted as partial fulfilment of the requirements for the award of a degree of Master of Education (Science education) of Rhodes University.
83. National Senior Certificate Diagnostic Chief Markers Report 2013. [www.gov.za](http://www.gov.za)
84. National Senior Certificate - Diagnostic Report, 2014. [www.ecexams.co.za](http://www.ecexams.co.za)
85. Ogunniyi M.B. and Taale K.D. (2004). Relative effects of a remedial instruction on grade seven learners conceptual of heat, magnetism and electricity. *African Journal of Research in SMT Education, Volume 8 (1) 2004*, pp 77 – 87.
86. Önder, I. 2006. The effect of Conceptual Change approach on students' understanding of solubility equilibrium concept.
87. Osborne, R. (1983). Towards modifying children's ideas about electric current. *Research in Science and Technology Education, 1(1)*, 73–82.
88. Osborne, R. (1981). Children's ideas about electric circuits. *New Zealand Science Teacher, 29*, 12-19.
89. Osborne, and Freyberg, P. (1996). Learning in Science the Implications of Children's Science. New Hampshire: Heinemann.
90. Pardhan, H. & Bano, Y. (2001). Science teachers' alternate conceptions about direct-currents. *International Journal of Science Education, 23 (3)*, 301-318.



91. Piaget, J. (1978). *Success and understanding*. London: Routledge and Kegan Paul.
92. Pollard, A. (1997). *Reflective Teaching*. Second edition. Evidence-informed Professional Practice. Continuum. London. New York
93. Posner G. J., Strike K.A., Hewson P.W. and Gertzog W. A. (1982). "Accommodation of a Scientific Conception: Toward a Theory of Conceptual Change." Department of Education, Cornell University, Ithaca, New York 14853.
94. Rankhumise. (2014). Running Head: Activity-Based Learning Using Activity-Based Instructional Approaches in Electric Circuits. *Mediterranean Journal of Social Sciences*.
95. Raskin J. D. (2002) Constructivism in psychology: Personal construct psychology, radical constructivism, and social constructionism. In: Raskin J. D. & Bridges S. K. (eds.) *Studies in meaning: Exploring constructivist psychology*. Pace University Press, New York: 1–25. Available at <http://cepa.info/3744>
96. Rasmussen, J. (1998). Constructivism and phenomenology: What do they have in common, and how can they be told apart? *An International Journal*, 29, 553-576.
97. Rudner, L. M., & Schafer, W.D. (2001) *Reliability*. ERIC Digest.
98. Richardson, V. (1997). *Constructivist Teacher Education: Building a World of New Understandings*. The Flamer Press, London, UK
99. Robottom, I. (2004). Constructivism in Environmental Education: Beyond Conceptual Change Theory. *Australian Journal of Environmental Education*, 20 (2), 93-101.
100. Rogers, A. & Horrocks, N. 2010. *Teaching Adults*. New York: McGraw Hill Open University Press.
101. Ronen, M., & Eliahu, M. (2000). Simulation—A bridge between theory and reality: The case of electric circuits. *Journal of Computer Assisted Learning*, 16, 14-26. doi:/10.1046/j.1365-2729.2000.00112.

102. Ruhf R. J. (2003). "A General Overview of Conceptual Change Research." Science and Mathematics Program Improvement (SAMPI), 1-16. Western Michigan University.
103. Rumelhart, D. (1980). Schemata: The building blocks of cognition. In R. J. Spiro, B. C. Bruce, & W. F. Brewer (Eds.), Theoretical issues in reading comprehension. Hillsdale, NJ: Erlbaum.
104. Roychoudhury, A. 1996. Interactions in an open-inquiry physics laboratory. *International Journal of Science Education*. Vol. 18, No. 4 (pp 423–445). [[Taylor & Francis Online](#)],[[Google Scholar](#)]
105. Sanger, J. (1996). The Compleat Observer? A field research guide to observation. The Falmer Press. Taylor and Francis Group. London. Washington. D.C.
106. Schmidt, H. J. (1997), Students' Misconceptions' Looking for a Pattern. *Science Education*, 81, 123-135.
107. Schunk, D.H. (2000). *Learning Theories. An educational Perspective* (6<sup>th</sup> Ed) Pearson New International Edition
108. Scott, P., Asoko, H. and Driver, R. (1991). Teaching for Conceptual Change: A review of Strategies, *Research in Physics Learning: Theoretical Issues and Empirical Studies*. In R. Duit, F. Goldberg and H. Niedderer (Ed.). Proceedings of an International Workshop. Kiel, University of Bremen, 310-329.
109. Scott, P.H., Asoko, H.M. & Driver, R.H. 1991. Teaching for conceptual change: a review of strategies. *Research in learning: theoretical issues and empirical studies*. Proceedings of an international workshop. Children's learning in science research group University of Leeds, UK.
110. Scott, D. & usher, R. (2011). *Researching Education. Data Methods and Theory in Educational Inquiry*. 2<sup>nd</sup> edition. London: Continuum.
111. Sebastia, J.M. (1993). "Cognitive mediator and interpretations of electric circuits" in Proceedings of the Third International Seminar of the Misconceptions and Educational Strategies in Science and Mathematics. (Misconceptions Trust, Ithaca, New York, 1993)



112. Selley, N. (1999). *The Art of Constructivist Teaching in the Primary School: A Guide for Students and Teachers*. David Fulton Publishers, London, UK.
113. She, H. C. (2003). DSLM Instructional Approach to Conceptual Change Involving Thermal Expansion. *Research in Science and Technological Education*, 21(1), 43-54.
114. Shipstone, D. M., von Rhöneck, C., Jung, W., Kärrqvist, C., Dupin, J. J., Joshua, S. & Licht, P. (1988). A study of students' understanding of electricity in five European countries. *International Journal of Science Education*, 10(3), 303-316.
115. Shuell, T. J. (1996). Teaching and learning in a classroom context. In D. C. Berliner & R. C. Calfee (Eds.), "*Handbook of educational psychology*" (pp. 726-764). New York: Macmillan Library Reference USA.
116. Sinatra, G. M., & Pintrich, P. R. (2003). *Intentional conceptual change*. Mahwah, NJ: Erlbaum.
117. Silverman D. (2006). *Interpreting Qualitative Data: Methods for Analysing Talk, Text and Interaction* (Third edition) [28 paragraphs]. *Forum Qualitative Sozialforschung / Forum: Qualitative Social Research*, 9(1), Art. Jan 16, 2008
118. Smith, E. L., Blakeslee, T. D., & Anderson, C.W. (1993). Teaching strategies associated with conceptual change. *Journal of Research in Science teaching*, 30(2), 111-126.
119. South Africa. Department of Education. 2014. *Education Statistics in South Africa*. Pretoria.
120. Department of Education, 2013 **see** South Africa. Department of Education. <http://education.gov.za>.
121. Stake, RE. (1994). Case Studies. In NK Denzin & YS Lincoln (Eds.) "*Handbook of Qualitative Research*" (pp. 236-247). Thousand Oaks, Sage Publications.
122. Stake, R. E. (1995). *The art of case study research*. Thousand Oaks, CA: Sage

123. Stavy, R. (1991). Using Analogy to Overcome About Conservation of Matter, *Journal of Research in Science Teaching*, 28 (4), 305-313.
124. Steffe, L.P.; Gale, J. (1995). *Constructivism in Education*. University of Georgia. First published by Lawrence Erlbaum Associates, Inc., Publishers. Routledge Taylor & Francis Group. New York and London
125. Suping, S.M. (2003). *Conceptual Change among Students in Science*. ERIC Clearing for Science Mathematics and Environmental Education. (ED482723)
126. Taylor, J.A. (2001). Using a Practical Context to Encourage Conceptual Change: An Instruction Sequence in Bicycle Science. *School Science & Mathematics*, 101 (2), 91-102.
127. Tiberghien, A. (1983). Critical Review On The Research Aimed At Elucidating The Sense That The Notions Of Electric Circuits Have For Students Aged 8 To 20 Years. In International summer workshop: research on physics education, La Londe les Maures. Paris: Arman Colin.
128. Tobin, K., & Tippins, D. (1993). Constructivism as a referent for teaching and learning. In K. Tobin (Ed.), *the practice of constructivism in science education*. Washington, DC: American Association for the Advancement of Science.
129. Treagust, D. F., & Duit, R. (2008). Conceptual change: A discussion of theoretical, methodological and practical challenges for science education. *Cultural Studies of Science Education*, 3, 297-328. doi:/10.1007/s11422-008-9090-4.
130. Treagust, D. F. & Duit, R. H. (2009). The challenges ahead for research and development on conceptual change in science. In U.H. Cheah, Wahyudi, R. P, Devadason, K. T. Ng, W. Preechaporn & J. C. Aligaen (Eds.). *Proceedings of the Third International Conference on Science and Mathematics Education (CoSMEd 2009)* (pp. 8 -14). Penang, Malaysia: The Regional Centre for Education in Science and Mathematics

131. von Glasersfeld, E. (1995). A constructivist approach to teaching. In Steffe, L. P., & Gale, J. (Eds.). *Constructivism in Education*. Hillsdale, NJ: Lawrence Erlbaum Associates
132. Vygotsky, L. S. (1978). In M. Cole, V. John-Steiner, S. Scribner, & E. Souberman (Eds.), *Mind in Society*. Cambridge, Mass.: Harvard University Press.
133. Wesi, R.P. 2003. Conceptual difficulties associated with the energy concept. Thesis, Potchefstroom: North-West University.
134. White, B., & Horwitz, P. (1988). Computer microworlds and conceptual change: A new approach to science education. In P. Ramsden (Ed.), *Improving learning: New perspectives*. London: Kogan Page.
135. Wing-Mui, W.O. (2002). Constructivist teaching in primary science. *Asia-Pacific Forum on Science Learning and Teaching*, 3(1), 1-33.
136. Woolfolk, A. (2010). *Educational Psychology*. 11th ed. London: Pearson Educational International.
137. Xipu, B. (2012). An investigation of how natural sciences teachers mediate learning of chemical reactions in Grade 9: A case study. 2012. Available at: <http://hdl.handle.net/10962/d1003513>.
138. Yin, RK. (1989). *Case Study Research: Design and Methods* (2nd ed.). Newbury Park, CA: Sage Publications.
139. Yin, R.K. (1994). *Case Study Research: Design and Methods*. Sage: London.
140. Zacharia, Z. C. (2007). Comparing and combining real and virtual experimentation: an effort to enhance students' conceptual understanding of electric circuits. *Journal of Computer Assisted Learning*, 23, 120-132
141. Zietsman, A. I. and Hewson, P. W. (1986), Effect of instruction using microcomputer simulations and conceptual change strategies on science learning. *J. Res. Sci. Teach.*, 23: 27–39. doi:10.1002/tea.3660230104



UNIVERSITY *of the*  
WESTERN CAPE

## APPENDIX 1



# University of the Western Cape

Faculty of Education, Private Bag X17, Bellville, South Africa

---

## APPENDIX 1: Background information sheet

Dear Sir/Madam,

My name is Fuzani Nomfundo, a Masters student in the School of Science and Maths Education of the Faculty of Education at the University of the Western Cape. I am conducting research on teaching electric circuits using conceptual change approach.

**Research Title:** Teaching electric circuits using conceptual change approach.

The research study is guided by the following research questions:

- How effective is a conceptual change teaching approach in enhancing their understanding of the electric circuits?

The research participants will comprise one Physical Science teacher and learners. Data collection will be in the form of tests, practical observations and interviews. Participation in this study is voluntary. Participants have the right to withdraw from the research at any stage of the research process without having to give any explanations. Participants are guaranteed utmost confidentiality regarding all information collected from them. Pseudonyms or a system of coding will be used to protect their identity.

Should you wish to find out more about the research, you are welcome to contact my supervisor, Professor M.S. Hartley, whose contact details are provided below or indeed me.

Yours sincerely

Researcher: Ms. Fuzani N.C.

Supervisor: Prof. Hartley M.S.

Contact number: 074 274 3189

Email: [nomfundofuzani@rocketmail.com](mailto:nomfundofuzani@rocketmail.com)

Tel. 021-9592680

Email: [shartley@uwc.ac.za](mailto:shartley@uwc.ac.za)

Signature of the researcher: ..... Date:.....



# University of the Western Cape

Faculty of Education, Private Bag X17, Bellville, South Africa

---

## APPENDIX 2: PERMISSION LETTER

### THE EASTERN CAPE DEPARTMENT of EDUCATION DEPARTMENT (ECDoE)

X Secondary School  
Stepping Stone Weg,  
7550  
Durbanville

The Research Director  
Eastern Cape Education Department  
P/B X0023  
Bisho  
5605



Dear \_\_\_\_\_

### Re: Permission to conduct research at X School

My name is **Fuzani Nomfundo**, a Masters student in the School of Science and Maths Education of the Faculty of Education at the University of the Western Cape. I would like to request your permission to observe learners' interaction in the Grade 10 Physical Science in one of the secondary schools in Cradock district.

I am conducting research on the conceptual change approach in teaching electric circuits. The target group will be Grade 10 Physical Science learners and teacher.

The research will not interfere in any way with the functioning of the school or with learning in the classroom. In addition, participation will be voluntary and so participants will be free to

withdraw at any time without giving reasons should they feel uncomfortable with my research. Their participation in the study will remain anonymous. Information received as part of the study will be used for research purposes only. It will not be used in any public platform for any purposes other than to teach electric circuit using conceptual change approach in grade 10.

Should you wish to find out more about the research, you are welcome to contact my supervisor, Professor Hartley, whose contact details are provided below or indeed me.

Yours sincerely,

Researcher: Ms. Fuzani N.C.  
Contact number: 074 274 3189  
Email: [nomfundofuzani@rocketmail.com](mailto:nomfundofuzani@rocketmail.com)

Supervisor: Prof. Hartley M. S.  
Tel. 021-9592680  
Email: [shartley@uwc.ac.za](mailto:shartley@uwc.ac.za)

Signature of the researcher: ..... Date:.....





# University of the Western Cape

Faculty of Education, Private Bag X17, Bellville, South Africa

---

## APPENDIX 3: PERMISSION LETTER

### THE PRINCIPAL X SECONDARY SCHOOL

X Secondary School,  
Stepping Stone Weg,  
7550  
Durbanville

Dear \_\_\_\_\_



### Re: Permission to conduct research in your School

UNIVERSITY of the  
WESTERN CAPE

My name is **Fuzani Nomfundo** a Masters student in the School of Science and Maths Education of the Faculty of Education at the University of the Western Cape. I am conducting research on teaching of electric circuits using conceptual change approach. The target group will be Grade 10 Physical Science class teacher and learners.

I would like to request your permission to observe Grade 10 teachers' and learners' interaction in the teaching of electric circuits using conceptual change approach. I request your permission to interview the Grade 10 teacher and learners.

The research will not interfere in any way with the functioning of the school or with learning in the classroom. In addition, participation will be voluntary and so participants will be free to withdraw at any time without giving reasons should they feel uncomfortable with my research. Your participation and that of the learners in the study will remain anonymous. Information received as part of the study will be used for research purposes only. It will not be used in any



public platform for any purposes other than to teach electric circuits using conceptual change approach in Physical Sciences in Grade 10 classroom.

Should you wish to find out more about the research, you are welcome to contact my supervisor, Professor Hartley, whose contact details are provided below or indeed me.

Yours sincerely,

Researcher: Ms. Fuzani N.C.

Supervisor: Prof. Hartley M. S.

Contact number: 074 274 3189

Tel. 021-9592680

Email: [nomfundofuzani@rocketmail.com](mailto:nomfundofuzani@rocketmail.com)

Email: [shartley@uwc.ac.za](mailto:shartley@uwc.ac.za)

Signature of the researcher: ..... Date: .....





# University of the Western Cape

Faculty of Education, Private Bag X17, Bellville, South Africa

---

## APPENDIX 4: PERMISSION LETTER

### THE Further Education and Training GRADE 10 TEACHER

X Secondary School,  
Stepping Stone Weg,  
7550  
Durbanville

Dear \_\_\_\_\_



### Re: Permission to conduct research in your Grade 10 Physical Sciences classroom

UNIVERSITY of the  
WESTERN CAPE

My name is **Fuzani Nomfundo** a Masters student in the School of Science and Maths Education of the Faculty of Education at the University of the Western Cape. I am conducting research on the teaching electric circuits using conceptual change approach. The target group will be Grade 10 Physical Science class teacher and learners.

I would like to request your permission to observe you and your learners during the Physical Sciences lessons in order to understand how conceptual change approach be used to teach electric circuits. I also request you to participate in the interviews.

The research will not interfere in any way with the functioning of the school or with teaching and learning in your classroom. In addition, participation will be voluntary and so participants will be free to withdraw at any time without giving reasons should they feel uncomfortable with my research. Your participation and that of the learners in the study will remain anonymous. Information received as part of the study will be used for research purposes only. It will not be

used in any public platform for any purposes other than to understand what would be the impact of using conceptual change approach in Grade 10 Physical Sciences class.

Should you wish to find out more about the research, you are welcome to contact my supervisor, Professor Hartley, whose contact details are provided below or indeed me.

Yours sincerely,

Researcher: Ms. Fuzani N.C.

Supervisor: Prof. Hartley M. S.

Contact number: 074 274 3189

Tel. 021-9592680

Email: [nomfundofuzani@rocketmail.com](mailto:nomfundofuzani@rocketmail.com)

Email: [shartley@uwc.ac.za](mailto:shartley@uwc.ac.za)

Signature of the researcher: ..... Date:.....





# University of the Western Cape

Faculty of Education, Private Bag X17, Bellville, South Africa

---

## APPENDIX 5: PERMISSION LETTER

### THE PARENTS

X Secondary School,  
Stepping Stone Weg,  
7550  
Durbanville

Dear \_\_\_\_\_



### **Re: Permission for your child's participation in a research in**

UNIVERSITY of the  
WESTERN CAPE

My name is **Fuzani Nomfundo** a Masters student in the School of Science and Maths Education of the Faculty of Education at the University of the Western Cape. I am conducting research on the teaching of electric circuits using conceptual change approach in Physical Sciences. The target group will be your Grade 10 Physical Science class.

I would like to request your permission to sit in your child's Physical Science class and observe how he/she interacts with his/her teacher and peers. I would also like to observe her/his written activities and interview him/her about their experiences on learning electric circuits.

The research will not disrupt the class schedules or teaching and learning in the classroom. In addition, participation will be voluntary, so participants will be free to withdraw at any time without giving reasons should they feel uncomfortable with my research. The identity of the learners in the study will remain anonymous. Information received as part of the study will be used

for research purposes only. It will not be used in any public platform for any purposes other than to be the impact of using conceptual change approach in Grade 10 Physical Sciences class.

Should you wish to find out more about the research, you are welcome to contact my supervisor, Professor Hartley, whose contact details are provided below or indeed me.

Yours sincerely,

Researcher: Ms. Fuzani N.C.

Supervisor: Prof. Hartley M. S.

Contact number: 074 274 3189

Tel. 021-9592680

Email: [nomfundofuzani@rocketmail.com](mailto:nomfundofuzani@rocketmail.com)

Email: [shartley@uwc.ac.za](mailto:shartley@uwc.ac.za)

Signature of the researcher: ..... Date: .....





# University of the Western Cape

Faculty of Education, Private Bag X17, Bellville, South Africa

---

## Appendix 6: Parents' Informed Consent form:

I agree son/daughter \_\_\_\_\_  
(name) can be part of the study and I am aware that my participation in this study is voluntary. If, for any reason, I wish to stop being part of the study, I may do so without having to give an explanation. I understand the intent and purpose of this study.

I am aware the data will be used for a Masters thesis and a research paper. I have the right to review, comment on, and/or withdraw information prior to the paper's submission. The data gathered in this study are confidential and anonymous with respect to my son/ daughter's personal identity, unless I specify or indicate otherwise. In the case of classroom observations and interviews, I have been promised that my son/ daughter's personal identity and that of the school will be protected, and that the normal classroom activities will not be disrupted by the researcher.

I have read and understood the above information. I give my consent to participate in the study.

\_\_\_\_\_

Parent's signature

\_\_\_\_\_

Date

\_\_\_\_\_

Researcher's signature

\_\_\_\_\_

Date



# University of the Western Cape

Faculty of Education, Private Bag X17, Bellville, South Africa

---

## Appendix 7: Participants' Informed Consent form:

I agree to be part of the study and I am aware that my participation in this study is voluntary. If, for any reason, I wish to stop being part of the study, I may do so without having to give an explanation. I understand the intent and purpose of this study.

I am aware the data will be used for a Masters thesis and a research paper. I have the right to review, comment on, and/or withdraw information prior to the paper's submission. The data gathered in this study are confidential and anonymous with respect to my personal identity, unless I specify or indicate otherwise. In the case of classroom observations and interviews, I have been promised that my personal identity and that of the school will be protected, and that my duties will not be disrupted by the researcher.

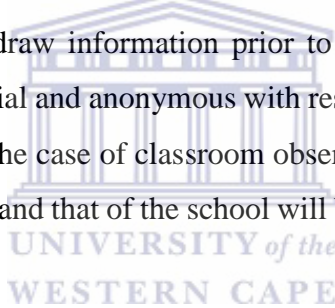

I have read and understood the above information. I give my consent to participate in the study.

\_\_\_\_\_

Participant's signature

\_\_\_\_\_

Date

\_\_\_\_\_

Researcher's signature

\_\_\_\_\_

Date

## A. DETAILED ANALYSIS OF RESULTS IN THE CRADOCK DISTRICT FOR PHYSICAL SCIENCE

PHYSICAL SCIENCE												
District: Cradock		Year: 2014				Grade: 12			Term: 4			
SCHOOL	No. of learners	Passed	Failed	% Passed	% Failed	LEVEL						
						7	6	5	4	3	2	1
CRADOCK HIGH	22	18	4	82%	18%	3	4	4	2	4	1	4
MICHAUSDAL												
JA CALATA	15	5	10	33%	67%	0	0	1	1	0	3	10
MATTHEW GONIWE	3	3	0	100%	0%	1	0	0	0	2	0	0
CRADOCK PRISON												
<b>TOTAL</b>	<b>40</b>	<b>26</b>	<b>14</b>	<b>65%</b>	<b>35%</b>	<b>4</b>	<b>4</b>	<b>5</b>	<b>3</b>	<b>6</b>	<b>4</b>	<b>14</b>
EKUPHUMLENI	3	1	2	33%	67%	0	0	0	0	0	1	2
MIDDELBURG HIGH	12	10	2	83%	17%	0	1	1	3	5	0	2
MIDDELLAND	2	2	0	100%	0%	0	0	0	1	1	0	0
<b>TOTAL</b>	<b>17</b>	<b>13</b>	<b>4</b>	<b>76%</b>	<b>24%</b>	<b>0</b>	<b>1</b>	<b>1</b>	<b>4</b>	<b>6</b>	<b>1</b>	<b>4</b>
PHAKAMA HOFMEYR												
TARKASTAD HIGH	5	5	0	100%	0%	0	2	0	1	2	0	0
RAYMOND MHLABA												
MARLOW	10	10	0	100%	0%	1	1	3	2	0	3	0
<b>TOTAL</b>	<b>15</b>	<b>15</b>	<b>0</b>	<b>100%</b>	<b>0%</b>	<b>1</b>	<b>3</b>	<b>3</b>	<b>3</b>	<b>2</b>	<b>3</b>	<b>0</b>
INYATHI	8	5	3	63%	38%	0	0	0	2	2	1	3
KOPANO	1	1	0	100%	0%	0	0	0	0	1	0	0
ZANABANTU	5	5	0	100%	0%	0	0	0	2	0	3	0
SIZAMILE												
MBEKWENI												
IKHWEZI	8	6	2	75%	25%	0	0	0	1	1	4	2
<b>TOTAL</b>	<b>22</b>	<b>17</b>	<b>5</b>	<b>77%</b>	<b>23%</b>	<b>0</b>	<b>0</b>	<b>0</b>	<b>5</b>	<b>4</b>	<b>8</b>	<b>5</b>
<b>DISTRICT TOTAL</b>	<b>94</b>	<b>71</b>	<b>23</b>	<b>76%</b>	<b>24%</b>	<b>5</b>	<b>8</b>	<b>9</b>	<b>15</b>	<b>18</b>	<b>16</b>	<b>23</b>

Capturer: T.E. HOCKEY

Figure 3: District results and analysis of results of Physical Science.



## B. PRE – TEST QUESTIONS

# Electrical circuits – Pre - Test

1. In a simple series circuit, why does the bulb light when you close the switch?

- Because the switch produces electricity
- Because closing the switch completes the circuit
- Because closing the switch breaks the circuit

2. In a simple series circuit, why does the bulb go out when you open the switch?

- Because the battery goes flat
- Because opening the switch breaks the circuit
- Because too much electricity flows through the bulb

3. Imagine a simple series circuit with one 1.5V battery and one bulb. When the 1.5V battery is replaced with a 3V battery ...

- the bulb gets brighter
- the bulb gets dimmer
- the bulb stays at the same level of brightness

4. Imagine a circuit with a 1.5V battery and one bulb. Imagine a similar circuit with a 3V battery and two bulbs. Which has the brightest bulbs?

- The circuit with a 1.5V battery and one bulb
- The circuit with a 3V battery and two bulbs
- The bulbs in both circuits are of similar brightness levels

5. Why might a bulb flash and go out when a 1.5V battery and a 3V battery are both connected across it in a simple series circuit?

- There is not enough electricity flowing around the circuit
- Too much electricity flows through the bulb's filament and the bulb blows
- The batteries are flat

6. What is the effect of changing the wire in a circuit from a straight thick wire to a straight thin wire?

- The bulbs become dimmer
- The bulbs become brighter
- The bulbs stay at the same level of brightness

7. What is the effect of changing the wire in a circuit from a straight thick wire to a longer (coiled) thick wire?

- The bulbs become dimmer
- The bulbs become brighter
- The bulbs stay at the same level of brightness

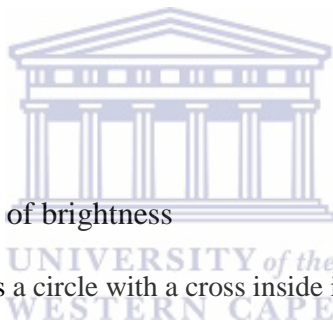

8. In a circuit diagram, what does a circle with a cross inside it represent?

- A light bulb
- A motor
- A battery

9. What do the long straight lines represent in a circuit diagram?

- Motors
- Light bulbs
- Wires

10. How is a battery represented in a circuit diagram?

- A circle with a cross inside it

- A circle with an M inside it
- A long line and a short line



## C. PRE – TEST MEMORANDUM

### Electrical circuits – Pre-test Memo

1. In a simple series circuit, why does the bulb light when you close the switch?

= Because closing the switch completes the circuit

2. In a simple series circuit, why does the bulb go out when you open the switch?

= Because opening the switch breaks the circuit

3. Imagine a simple series circuit with one 1.5V battery and one bulb. When the 1.5V battery is replaced with a 3V battery ...

= the bulb gets brighter

4. Imagine a circuit with a 1.5V battery and one bulb. Imagine a similar circuit with a 3V battery and two bulbs. Which has the brightest bulbs?

= The bulbs in both circuits are of similar brightness levels

5. Why might a bulb flash and go out when a 1.5V battery and a 3V battery are both connected across it in a simple series circuit?

= Too much electricity flows through the bulb's filament and the bulb blows

6. What is the effect of changing the wire in a circuit from a straight thick wire to a straight thin wire?

= The bulbs become dimmer

7. What is the effect of changing the wire in a circuit from a straight thick wire to a longer (coiled) thick wire?

= The bulbs become dimmer

8. In a circuit diagram, what does a circle with a cross inside it represent? = A bulb

9. What do the long straight lines represent in a circuit diagram?

= Electric Wires

10. How is a battery represented in a circuit diagram?

= A long line and a short line

## D. INTERVIEW SCHEDULE

### Interview with the Grade 10 Physical Science Learners (English)

#### INSTRUMENT: LEARNER INTERVIEW SCHEDULE

##### Learner Personal Information:

Name of learner: \_\_\_\_\_ Gender: \_\_\_\_\_

Age:.....Race:.....

Name of school:.....Number of years in this grade.....

Interviewer's name: \_\_\_\_\_ Date: \_\_\_\_\_

##### Interview Questions:

1. What was your understanding of Physical Science before you participate in the program?
2. Do you feel confident about what you have learnt so far? How can you reveal that to a person who needs assistance in this topic.
3. If you were asked to compare your understanding of the Physical Science before this project was undertaken and now that you have been exposed to this pilot program, how would you explain it?
4. How do you feel about the mark you obtain on the post-test after you have participated in the program?
5. Would you recommend that the teaching strategy used be extended to your entire learning?
6. Do you feel confident that what has been taught in this program will allow you to develop a greater understanding of the concepts? To what extent?

## E. PRACTICAL INVESTIGATION GUIDELINES

### 2017 LEARNER GUIDE

#### GRADE 10

#### EXPERIMENT 2

##### 1. TOPIC

Write the topic as given by the educator.

##### 2. AIM

Develop the aim of the experiment from the given topic. [2]

##### 3. APPARATUS

List the relevant apparatus. [2]

##### 4. GENERAL PRECAUTIONS AND CONDUCTING THE EXPERIMENT

4.1 Mention the special precaution for this experiment. (2)

4.2 Conduct the experiment. Will be evaluated by the teacher while you are busy.

(Rubric) (6)

[8]

##### 5. RESISTORS IN SERIES

###### 5.1 METHOD

Write the procedure/method you will use. (3)

###### 5.2. OBSERVATIONS

Explain the changes taking place during the experiment. (2)

###### 5.3. DATA COLLECTION

Take all the required measurements and record your readings in a table. Sketch your circuit. (10)

[15]

##### 6. RESISTORS IN PARALLEL

###### 6.1. METHOD

Write the procedure/method you will use. (3)

###### 6.2. OBSERVATIONS

Explain the changes taking place during the experiment. (2)

###### 6.3. DATA COLLECTION/DATA VERSAMELING

146

Take all the required measurements and record your readings in a table. Sketch your circuit. (10)

**[15]**

### **7. DATA ANALYSIS AND INTERPRETATION**

Analyse and interpret the data on both tables. Identify relationships (trends and patterns).

**[4]**

### **8. CONCLUSION**

Write a relevant conclusion based on the experiment.

**[4]**

**[40]**

**Convert the TOTAL = 50 marks**



**F. LEARNERS' WORKSHEET**

**GRADE 10** \_\_\_\_\_

**2017      EXPERIMENT 2: WORK SHEET**

**NAME OF LEARNER:** \_\_\_\_\_

1. Topic.

---

---

---

2. Aim

---

---

---

3. Apparatus



**[2]**

UNIVERSITY of the  
WESTERN CAPE

**[2]**

4. General precautions and conducting the experiment.

4.1 Precautions.

---

---

(2)

4.2 Conducting the experiment.

(Marked with a rubric.)

(6)

**[8]**

**5. RESISTORS IN SERIE(S)**

5.1 Method.



---



---



---

(3)

5.2. Observations.

---



---



---



---

(2)

5.3 Data collection.

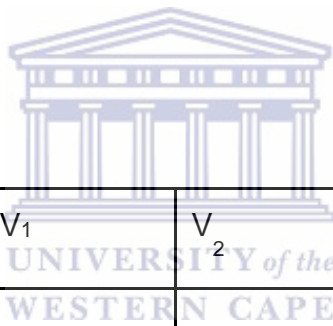

VOLTMETER READING	V <sub>1</sub>	V <sub>2</sub>	V <sub>3</sub>	V <sub>4</sub>
AMMETER READING	A	A	A	A

(6)

Sketch your circuit

(You will be provided with extra papers to do your sketch of your circuit)

(4)

**[15]**

**6. PARALLEL RESISTORS**

6.1 Method.

---



---



---

(3)

6.2 Observations.

---

---

---

---

(2)

6.3 Data collection.

AMMETER READING	A <sub>1</sub>	A <sub>2</sub>	A <sub>3</sub>	A <sub>4</sub>
VOLTMETER READING	V	V	V	V

(6)

Sketch your circuit

(You will be provided with extra papers to do your sketch of your circuit)

(4)

**[15]**

7. Data analysis and interpretation.

7.1 Series.

---

---

---

---

(2)

7.2 Parallel.

---

---

---

---

(2)  
[4]

8. Conclusion.

---

---

---

---

[4]

**TOTAL 40**

**Convert the TOTAL = 50 marks**



## G. PRACTICAL INVESTIGATION MARKING GUIDELINES

**GRAAD 10            2017    EKSPERIMENT 2: MARKING GUIDELINE**

### 1. Topic

To investigate that series resistors are potential dividers and parallel resistors are current dividers.

### 2. Aim

To confirm that resistors in series are potential dividers and resistors in parallel are current dividers. ✓✓

[2]

### 3. Apparatus

4 voltmeters, 4 ammeters, 3 cells, conducting wires  
3 bulbs or resistors.

(2 if all are given, otherwise 1)

[2]

### 4. General precautions and conducting the experiment.

#### 4.1 Precautions.

Resistors must be identical. Prevent resistors getting hot. Calibrate meters.

(any 2)

(2)

4.2 Conducting the experiment  
(Marked with a rubric)

Criteria	Level descriptors			
	1	2	3	4
<b>The way in which the experiment is conducted. Die manier waarop die experiment uitgevoer word.</b>	<b>1 mark/punt</b>	<b>2-3 marks/punte</b>	<b>4-5 marks/punte</b>	<b>6 marks/punte</b>
	Maximum help is given to enable the learner to go on with the experiment. Maksimum hulp word verleen om die leerder in staat te stel om aan te gaan met die eksperiment.	Help is given regularly to enable the learner to go on with the experiment. Gereelde hulp word verleen om die leerder in staat te stel om aan te gaan met die eksperiment.	Minimal help is given to enable the learner to continue on his own. Minimale hulp word verleen om die leerder in staat te stel om self aan te gaan met die eksperiment.	No help is given and the learner successfully completes the experiment on his/her own. Geen hulp word verleen nie en die leerder voltooi die eksperiment suksesvol op sy/haar eie.

(6)

**[8]**

**5. RESISTORS IN SERIE(S)**

5.1 Method

Connect the cells, ammeter and resistors one after another without any branches in the circuit. ✓Connect the voltmeters over each resistor and one over all the resistors in the circuit. ✓Connect the ammeter in four different

places. ✓

(3)

### 5.2.Observations

If bulbs are used all the bulbs glow with the same brightness. If one is removed they all go out. The voltmeter reading over all the resistors/bulbs is equal to the sum of the individual readings. ✓ The ammeter readings are all the same. ✓ (2)

### 5.3 Data collection.

VOLTMETERLEESING/ VOLTMETER READING	$V_1$	$V_2$	$V_3$	$V_4$
	Smaller readings that are the same. ✓✓			Total of the three. ✓✓
AMMETERLEESING/ AMMETER READING	A	A	A	A
	All the readings must be the same. ✓✓			

Must record the actual readings. Mark according to the comment. Only one mark for poor / inaccurate results.

(6)

Sketch your circuit.

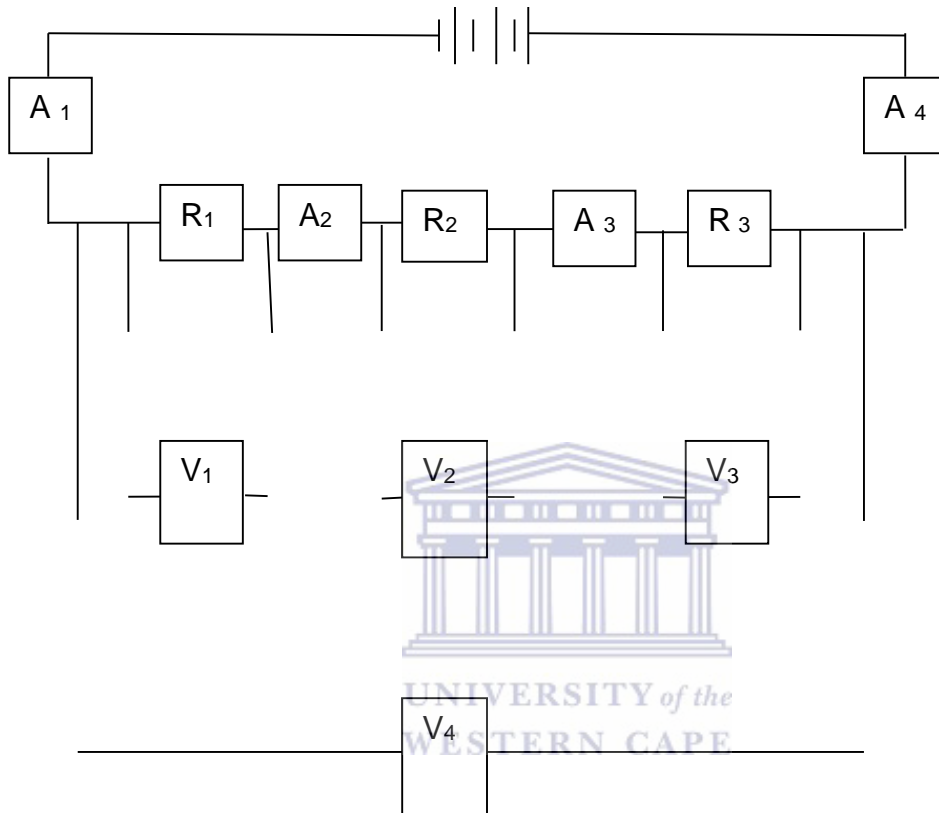

(4)

Total circuit correct✓, resistors in series✓, voltmeters in parallel✓, ammeters in series✓.

[15]

## 6. PARALLEL RESISTORS

### 6.1 Method.

Connect the cells and one ammeter in series and resistors one next to each other to form three branches in the circuit. ✓Connect the one voltmeter over

all the resistors and the others over the resistor in each branch. ✓ Connect the three ammeters, one in each branch. ✓ (3

6.2 Observations.

If bulbs are used all the bulbs glow with the same brightness and much brighter than the series connection. If one is removed the others continue to burn with the same brightness. The voltmeter readings over each resistor/bulb are the same as the reading over all three. ✓ The ammeter reading over all the resistors/bulbs is equal to the sum of the individual readings. ✓ (2

6.3 Data collection.

AMMETERLEESING/ AMMETER READING	A <sub>1</sub>	A <sub>2</sub>	A <sub>3</sub>	A <sub>4</sub>
	Smaller readings that are the same. ✓✓			Total of the three. ✓✓
VOLTMETER LEESING/VOLTMETER READING	V <sub>1</sub>	V <sub>2</sub>	V <sub>3</sub>	V <sub>4</sub>
	All the readings must be the same. ✓✓			

(6)



Sketch your circuit

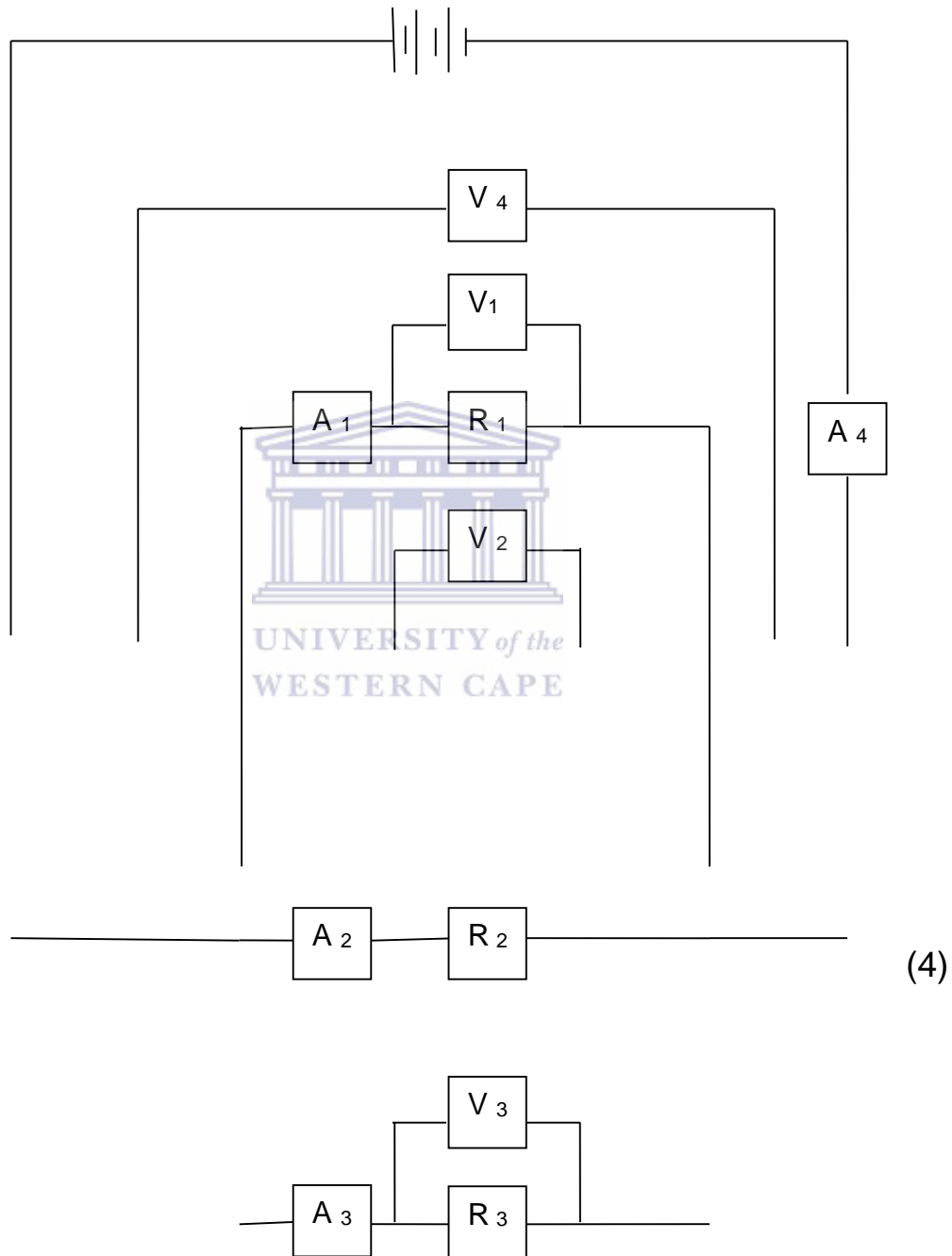

Total circuit correct, ✓ resistors in parallel, ✓ voltmeters in parallel,

✓ammeters in series. ✓

[15]

## 7. Data analysis and interpretation.

### 7.1 Series

$I_1 = I_2 = I_3 = I_4$  or in words

$V_4 = V_1 + V_2 + V_3$  or in words ✓

Divide the potential. ✓

(2)

### 7.2 Parallel.

$V_1 = V_2 = V_3 = V_4$  or in words.

$I_4 = I_1 + I_2 + I_3$  ✓ or in words.

Divide the current. ✓



(2)

[4]

## 8. Conclusion.

This experiment confirms that resistors in series are potential dividers. The current remains the same in the circuit. ✓✓

This experiment confirms that resistors in parallel are current dividers. The potential difference over the resistors connected in parallel remains the same. ✓✓

[4]

**TOTAAL/TOTAL 50**

Converted to a mark out of 20 for your SBA mark.

Omgesit na 'n punt uit 20 vir jou SGA punt.

## H. LESSON PRESENTATION

### LESSON PLAN 1

<b>Subject:</b> Physical Science		Number of activities
<b>Lesson Plan:</b> Electric Currents		
4		Week
<b>Duration:</b> 4H00		
5		
<b>Context:</b> Series and parallel connections		
<b>Prior knowledge:</b> Learners must be able to connect a simple circuit diagram. Knowledge of simple electric components, illustrations and diagrams.		
<p><b>Aim:</b> learners must be able to understand that: -</p> <ul style="list-style-type: none"> <li>• the electric currents that it only flow when a circuit is complete</li> <li>• conductors are materials that conduct electric currents</li> <li>• insulators are materials that do not conduct electric currents</li> <li>• electricity is a form of energy</li> <li>• electric energy can be stored in batteries</li> </ul> <p>Learners must be able to work cooperatively with partners/group and ensure everyone has sufficient opportunities to see and understand the activities handle equipment responsibly Learners must be able to know how to live in a healthy society. Learners must be able to come up with projects that will help them to develop their community</p>		
<b>LTSM:</b> Magazine picture, Worksheet, Textbook. Electric parts gadgets/ instruments.		
<b>Activity content</b>	<b>Activity 1 (Dissatisfaction)</b>	<b>Activity 2 (Intelligibly)</b>
<b>Detail of activity</b>	<p>Lesson presentation – (Discussion Activity 1)</p> <p>“how did you make the current flow through the light bulb?”</p> <p>“what things prevented your circuit from working?”</p> <p>“once your circuit was working, how did you stop the light bulb glowing?”</p> <p>(Introduce Activity 2 during which students will modify their circuits to construct series and parallel connections. )</p>	<p>Distribute or collect materials.</p> <p>Learners experiment through trial and error with materials provided to make the light bulb glow.</p> <p>Monitor progress and use questions and hints to assist learner's/groups in achieving a working circuit – see teacher notes for common difficulties encountered by learner's.</p>
	<b>Activity 3 (Intelligible)</b>	<b>Activity 4 (Fruitfulness)</b>
	Learners will be given materials to conduct experiment and worksheets.	Build a torch using recycled material.

	The experiment is based on series and parallel connection	
<b>Teaching method</b>	Presentation, Q+A discussion	Demonstration, Q+A discussion
<b>Assessment strategies</b>	Worksheet, classwork, memo	Worksheet, classwork, memo
<b>Expanded opportunities</b>	Homework	Homework
<b>Misconceptions</b>		
<b>Teacher reflection</b>	(Teacher will reflect after the lesson has been completed.)	(Teacher will reflect after the lesson has been completed.)

## Build a simple torch.

### Procedure

#### 1. How does a torch work?

Before you begin experimenting try drawing the inner workings of how you think a torch works in your science journal. Include the battery (or batteries), light bulb and switch.

#### 2. Make aluminium foil wires

To make a simple, strong wire for your experiments, take a rectangular piece of aluminium foil about 30 × 15 cm and fold it in half. Keep folding the foil this way until you have a long flat 'wire' about 1.5cm wide.

#### 3. Making current flow

Using your aluminium wires, battery, light bulb and any other items you have at your disposal, try to make a complete circuit. When you are successful, electric current will flow through the wires and the light bulb so that it glows bright.

#### 4. Make improvements

When you have mastered making a current flow, experiment with ways to make your circuit sturdier. Use whatever items or materials you have at your disposal to improve your design. You might even design an on/off switch. If something doesn't work after a few attempts, just stop and look for another way to make your idea work.

#### What have you discovered?

How do you think a torch works?

Does your new drawing match the one you made earlier?

Can you describe what you have learnt about how electric currents flow?

## I. QUESTION – BY – QUESTION ANALYSIS

### PRE – TEST RESULTS.

Surname	First name and other initials	Mark 10	Q1 out of 1	Q2 out of 1	Q3 out of 1	Q4 out of 1	Q5 out of 1	Q6 out of 1	Q7 out of 1	Q8 out of 1	Q9 out of 1	Q10 out of 1
1		3	1	0	0	0	0	1	0	0	1	0
2		2	1	0	0	0	0	0	0	0	1	0
3		2	0	0	0	0	1	0	1	0	0	0
4		3	1	0	0	1	1	0	0	0	0	0
5		4	1	1	0	1	0	0	0	0	1	0
6		3	0	0	0	0	0	1	0	0	1	1
7		3	1	0	0	0	0	0	1	1	0	0
8		3	0	0	1	0	0	0	0	0	1	1
9		3	0	0	0	1	0	0	0	1	1	0
10		3	0	0	0	1	0	0	0	0	1	1
11		2	0	0	1	0	0	1	0	0	0	0
12		4	1	0	1	1	0	0	1	0	0	0
13		3	0	0	1	0	0	0	1	1	0	0
14		1	0	0	0	0	0	0	1	0	0	0
15		1	0	0	0	0	0	0	1	0	0	0
16		3	0	0	0	0	0	0	1	0	1	1
17		2	0	0	0	0	0	0	1	1	0	0
18		4	1	0	0	1	0	0	0	1	1	0
19		3	0	0	0	0	0	0	1	1	0	1

20		5	1	0	1	1	0	0	0	0	0	0
21		2	0	0	0	0	0	1	0	0	0	0
22		3	0	0	0	0	0	1	0	0	0	0
23		4	1	0	1	1	0	1	0	0	0	0
24		1	0	0	0	0	0	1	0	0	0	0
25		2	0	0	0	0	0	1	0	1	0	0
26		5	1	0	1	1	0	1	0	1	0	0
27		1	0	0	0	0	0	0	0	1	0	0
28		4	1	0	0	0	1	0	0	1	1	0
29		4	1	1	0	1	1	0	0	0	0	0
30		2	0	0	0	0	0	0	0	0	1	1
31		3	1	0	0	0	1	0	0	0	1	0
32		3	1	0	0	0	1	0	0	0	1	0
33		2	0	0	0	0	0	0	0	0	1	1
34		6	1	1	0	1	1	0	0	0	1	1
35		1	0	0	0	0	0	0	0	0	0	1
36		3	1	0	0	0	1	0	0	0	1	0
37		3	1	0	0	1	1	0	0	0	0	0
38		2	1	0	0	0	0	1	0	0	0	0
39		1	1	0	0	0	0	0	0	0	0	0
40		4	1	0	0	1	1	0	1	0	0	0
Total mark per question		113	20	3	7	13	10	10	10	10	16	9
Average mark per question		3	1	0	0	0	0	0	0	0	0	0
Average % per question		28%	50%	8%	18%	33%	25%	25%	25%	25%	40%	23%

Official	Name in print	Signature	Date	Stamp
Teacher	Ms. N. Fuzani		20/06/2016	
Subject Head			20/06/2016	
Principal			20/06/2016	
Cluster Leader				
District Official				



UNIVERSITY of the  
WESTERN CAPE

## J. POST – TEST QUESTIONNAIRE

### A. TEST

Marks: 20

Learner name: \_\_\_\_\_ Age: \_\_\_\_\_

Gender: Male/ Female      School name: \_\_\_\_\_

#### Answer all questions:

1. What do you understand about electricity? (2)

---

---

2. List all the components that are needed to build a simple electric circuit diagram.

---

---

---

(4)

3. What do we call the power source in the diagram shown below? (1)

---

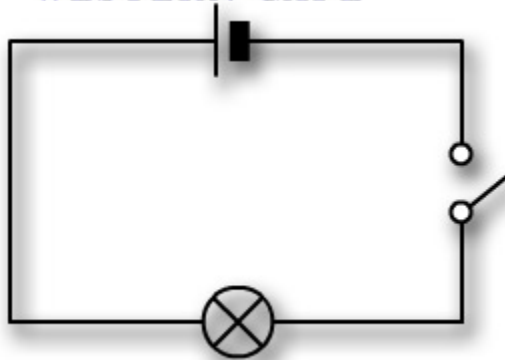

4. Explain how would you connect a voltmeter in a circuit? (2)

5. Have you ever worked with an ammeter and explain how do you connect it? (4)



- 
- 
- 
6. Are you in a position to assist with any electrical appliances at home like changing a plug or a light bulb? Name which one you can fix or both. (1)

- 
7. How best do you understand the concepts series and parallel connection? Give a clear distinction between them. (4)

8. Draw a series and parallel connection diagrams using two bulbs and two cells, switch, ammeter and voltmeter. (2 x 2)

**Total = 20**



UNIVERSITY *of the*  
WESTERN CAPE

**CONVERT MARKS = 30**

## K. POST – TEST MEMORANDUM

### MEMORANDUM

1. Electricity is the flow of moving electrons in a form of a charge. When the flow of moving charges is called electrical current. √√
2. Cell(s), connecting wires, switch, bulb. √√√√
3. Cell and battery √
4. Voltmeter is connected across the resistor/ bulb or a battery. √√
5. Yes/ no √. An ammeter is connected in series in the circuit diagram. √
6. Bulb/ plug/ Both. √
7. Series connection is when the bulbs/ resistors are connected in series (next to each other) in the circuit diagram. √√ Parallel connection is when the bulbs/ resistors are connected across each other or parallel to each other in a circuit diagram. √√
8. (Two marks for the correct connection total 4 marks) √√√√