

# Accepted Manuscript

Reliability Assessment for Hybrid Systems of Advanced Treatment Units of Industrial Wastewater Reuse Using Combined Event Tree and Fuzzy Fault Tree Analyses

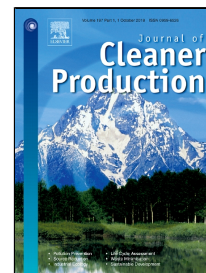

Farzad Piadeh, Mohsen Ahmadi, Kourosh Behzadian

PII: S0959-6526(18)32386-2  
DOI: 10.1016/j.jclepro.2018.08.052  
Reference: JCLP 13836  
To appear in: *Journal of Cleaner Production*  
Received Date: 14 September 2017  
Accepted Date: 05 August 2018

Please cite this article as: Farzad Piadeh, Mohsen Ahmadi, Kourosh Behzadian, Reliability Assessment for Hybrid Systems of Advanced Treatment Units of Industrial Wastewater Reuse Using Combined Event Tree and Fuzzy Fault Tree Analyses, *Journal of Cleaner Production* (2018), doi: 10.1016/j.jclepro.2018.08.052

This is a PDF file of an unedited manuscript that has been accepted for publication. As a service to our customers we are providing this early version of the manuscript. The manuscript will undergo copyediting, typesetting, and review of the resulting proof before it is published in its final form. Please note that during the production process errors may be discovered which could affect the content, and all legal disclaimers that apply to the journal pertain.

# 1 Reliability Assessment for Hybrid Systems of Advanced Treatment Units of 2 Industrial Wastewater Reuse Using Combined Event Tree and Fuzzy Fault 3 Tree Analyses

4 Farzad Piadeh<sup>a</sup>, Mohsen Ahmadi<sup>a</sup>, Kouros Behzadian<sup>b,1</sup>

5 <sup>a</sup> Civil and Environmental Engineering Department, Amirkabir University of Technology, Hafez St., Tehran, Iran

6 <sup>b</sup> School of Computing and Engineering, University of West London, St Mary's Rd, London, W5 5RF, UK

## 7 Abstract

8 Advanced treatment units (ATUs) are highly recommended for industrial wastewater reuse in the  
9 developing countries especially in arid and semi-arid areas. Reliability of a hybrid treatment  
10 system comprised of a number of individual ATUs remains blur due to lack of conceptual  
11 framework, collected data or experience in failure performance analysis of these treatment  
12 systems. This paper presents a new methodological framework for assessing reliability of hybrid  
13 system alternatives in industrial wastewater treatment by using combined event tree analysis  
14 (ETA) and fault tree analysis (FTA). The framework comprises three major steps: (1) identification  
15 of feasible alternatives; (2) reliability analysis assessment using combined FTA and ETA with  
16 fuzzy logic techniques to calculate first failure probability of individual ATUs and then reliability  
17 of each hybrid system alternative; (3) prioritisation of alternatives. Failure probability rate of  
18 events in FTA is determined by experts' judgement. The suggested framework is demonstrated  
19 through its application to a real case study of wastewater treatment plants of industrial parks in  
20 Iran. The results show the highest failure probabilities are reverse osmosis unit with 30% and  
21 ozonation unit with 24%, while coagulation and flotation unit has the lowest failure probability of  
22 5.4%. The most reliable alternative of hybrid system is comprised of sand filter + activated carbon  
23 + micro filter + ultra-filter + ion exchange with 74.82% reliability. Results in this study also show  
24 that selecting ATUs with higher removal efficiencies or rate of acceptable scenarios to form a  
25 hybrid ATU system cannot necessarily lead to a more reliable hybrid system without performing  
26 suggested FTA and ETA in this paper.

27 **Keywords:** Advanced Treatment Units, Event tree analysis, Fault tree analysis, Fuzzy logic,  
28 Hybrid systems of industrial wastewater, Reliability.

---

<sup>1</sup> Corresponding author. Tel.: +44 (0) 20 8231 2466  
E-mail address: [kouros.behzadian@uwl.ac.uk](mailto:kouros.behzadian@uwl.ac.uk)

## 1 **1 Introduction**

2 Nowadays, advanced treatment units (ATUs) are widely used for industrial wastewater  
3 treatment in order to not only prevent discharging contaminated wastewater to receiving water  
4 bodies but also provide opportunities for non-conventional water resources (Mya and Groth, 2011;  
5 Zhu *et al.*, 2015). This new way of cleaner production particularly is of paramount importance to  
6 developing countries especially located in arid and semi-arid areas usually suffering from lack of  
7 sufficient fresh water. Selection of the best sustainable combination of ATUs in series as a hybrid  
8 system in industrial wastewater treatment plant (WWTP) can sometimes turn out to be a serious  
9 challenge due mainly to uncertainties available in the operation of ATUs (Piadeh *et al.*, 2014).  
10 This can be even more challenging in developing countries where the sustainable performance of  
11 ATUs cannot be easily determined due to some major reasons including (1) different purposes for  
12 treatment of a hybrid ATU system and lack of collected data or required experience and knowledge  
13 for operation of such systems (Chong, 2012), (2) inability to recognise vulnerable points for a  
14 hybrid system in operation (Silva, 2014), and (3) major concerns about failure of such systems  
15 during the operational phase (Kalbar, 2012). Thus, an assessment framework for analysis of the  
16 performance of these systems is highly recommended.

17 Many researches have proposed set of indices for sustainability performance assessment of  
18 hybrid ATU systems (Piadeh *et al.*, 2018; Castillo *et al.*, 2017; Mahjouri *et al.* 2017). Among all,  
19 reliability can be understood as one of the main criteria in assessment methods for analyse of the  
20 sustainability performance in hybrid ATU systems during the operational phase (Zhang *et al.*,  
21 2012; Chong *et al.*, 2012). Improvement of operational reliability in hybrid systems can also have  
22 a direct impact on minimisation of future failures related to undesirable operation and hence  
23 indirectly influence other criteria such as economic (e.g. repair costs), technical (e.g. delivery of  
24 desirable removal efficiency and social (e.g. stakeholder satisfactory) aspects.

25 The first attempts about reliability assessment of wastewater treatment were made around the  
26 late 20<sup>th</sup> century and related to fault diagnostic or fault tree analysis (Harris, 1985). Fault tree and  
27 event tree analyses were employed widely for assessment of failure, risk or reliability in different  
28 industries such as oil and gas transmission pipelines (Yuhua and Datao, 2005), highway tunnels  
29 (Nývlt *et al.*, 2011) and nuclear power plants (Purba, 2014). Although these analyses have also  
30 been used in water and wastewater treatment, their applications have been limited to some specific

1 applications and definitions. Metcalf & Eddy (2003) defines reliability in water and wastewater  
2 industry as the possibility of obtaining expected adequate effluent quality in a specific period under  
3 certain conditions. Fault tree analysis is used more frequently for water distribution networks  
4 (Gouri and Srinivas, 2015; Gutpa and Rathi, 2017).

5 Some recent applications and definitions of reliability assessment in wastewater treatment  
6 systems are summarised in Table 1. The reliability assessments with qualitative methods in the  
7 Table were all provided by expert opinions without quantitative methods. This assessment method  
8 cannot be simply applied for other areas especially developing countries where enough experience  
9 is unavailable for running advanced treatment units. The other method, i.e. percentage of desirable  
10 effluent quality, is strictly dependent on the ability of treatment system to provide the required  
11 water or treated wastewater regardless the probability of unit's working. The last method,  
12 coefficient of reliability as a quantitative method, needs a large volume of precise historical data.  
13 However, this is the main obstacle for the cases when no or little historic data are available. Hence,  
14 an appropriate method is required for quantification of failure probability rates of ATUs for the  
15 cases with no historical data or poor quality of available data. Despite many failure probability  
16 assessments in different industries including wastewater treatment industry, they have been  
17 applied for a single processing unit not for combined failure assessment of a number of units in  
18 series as hybrid systems. In particular, some research works considered a correlation between the  
19 removal efficiency and reliability and hence ranked the reliability of alternatives based on their  
20 ability for removing pollutants (Arroyo and Molinos-Senante, 2018; Di Iaconi *et al.*, 2017). These  
21 studies assume that the treatment system works all times with maximum efficiency without failure  
22 during their life-cycle (Oliveira and Von Sperling, 2008; Alderson *et al.*, 2015). In addition,  
23 designers usually prefer to select ATUs in a hybrid system of wastewater treatment based on two  
24 approaches (ISIPO, 2016): (1) selecting ATUs with higher removal efficiency ; (2) selecting ATUs  
25 with larger reliability. However, both approaches fail to consider the effects of faulty ATUs in a  
26 hybrid system and hence the overall reliability of the hybrid system cannot be analysed properly.

**Table 1 Recent applications and definitions of reliability assessment in wastewater treatment systems**

Treatment processes	Reliability definition	Assessment method	Reference
166 full-scale wastewater treatment plants with 2 or 3 hybrid units	Probability of achieving adequate performance for a specific period of time under specific conditions	Coefficient of reliability	Oliveira and Von Sperling, 2008
EA <sup>1</sup> , AB <sup>2</sup> , IFAS <sup>3</sup> , SBR <sup>4</sup> , AL <sup>5</sup>	Long-term reliability of the processes	Qualitative	Karimi <i>et al.</i> , 2011
AS <sup>6</sup> , SBR, MBR <sup>7</sup>	Probability of mechanical failures and the impact of failures upon effluent quality for variability of treatment effectiveness under normal and emergency operation	Qualitative	Kablbar <i>et al.</i> , 2012
CW <sup>8</sup> , PS <sup>9</sup> , EA, MBR, RBC <sup>10</sup> , TF <sup>11</sup> , SBR	As above	Qualitative	Molinos-Senante <i>et al.</i> , 2014
56 wastewater treatment plant with hybrid systems	Reaching removal efficiency with desired national standard	Coefficient of reliability	Alderson <i>et al.</i> , 2015
CW	Reaching acceptable removal efficiency	Percentage of removal efficiency	Wojciechowska <i>et al.</i> , 2016
CW	Reaching acceptable removal efficiency	Percentage of removal efficiency	Jóźwiakowski <i>et al.</i> , 2017
SBBGR <sup>12</sup>	Reaching acceptable removal efficiency	Qualitative	Di Iaconi <i>et al.</i> , 2017
General wastewater treatment systems	Reaching required level of treatment, or system shutdown due to hardware or process problem, or enduring shock load due to the influent characteristics variation, or system performance in face of weather variation	Qualitative	Mahjouri <i>et al.</i> , 2017
20 hybrid systems	Mechanical reliability and water quality reliability	Qualitative	Akhoundi and Nazif, 2018
CW	Ability to remove amount of pollutants	Weibull analysis	Jóźwiakowski <i>et al.</i> , 2018
TF, SBR, RBC, PS, MBR, CW	Reaching the removal efficiency to the desired standard	Qualitative	Arroyo and Molinos-Senante., 2018
8 hybrid systems	Excessive loads of hydraulic, organic (COD), TSS or corrosions	Qualitative	Piadeh <i>et al.</i> , 2018

1 Most of the research works as described in Table 1 has focused on reliability assessments of  
2 secondary treatment units such as either individual units (e.g. SBR, IFAS and CW) or hybrid  
3 systems, which used for meeting the standards to improve the quality of wastewater for consumers  
4 who do not need high quality water. However, advanced treatment units are necessary in order to  
5 completely treat the wastewater as a new water resource instead of fresh industrial water. Only  
6 few analysed reliability assessment for some specific advanced treatment units. More specifically,  
7 Kalbar *et al.* (2012) that investigated a hybrid system containing three MBR units assumed MBR  
8 has the highest reliability rate (i.e. 100%) while the reliability of MBR systems was reported  
9 moderate (50%) by Molinos-Senante *et al.* (2014) and 30% by Arroyo and Molinos-Senante  
10 (2018). This highly variable rate for reliability of MBR systems shows various conditions and  
11 technological manufacturing of MBR systems that led to a large range between experts. Despite  
12 several recent advances in the development of reliability-based assessments in industrial WWTPs,  
13 to the best of author's knowledge, none of the previous works has presented a quantitative method  
14 to measure and compare the reliability of ATUs and more importantly investigate the reliability of  
15 hybrid ATU systems comprised of a number of individual ATUs in industrial wastewater  
16 treatment. Hence, this paper aims to develop a methodology for reliability assessment of hybrid  
17 ATU systems of industrial treatment by using an analytical method comprised of event tree and  
18 fault tree analyses. The paper also aims to integrate event tree and fault tree analyses into fuzzy  
19 logic and experts' opinions to quantify the failure data used for reliability assessment of hybrid  
20 ATU. This can lead to determine failure probability of individual ATUs and then reliability of  
21 hybrid systems. This method can be used to identify appropriate hybrid system alternatives for  
22 industrial treatment. Next section describes the suggested methodology followed by illustrating  
23 feasible alternatives, acceptable state and event tree and fault tree in a real case study. The results  
24 are then discussed and key findings are finally summarised along with future works.

## 25 **2 Materials and methods**

### 26 **2.1 Framework of reliability assessment**

27 A new framework for reliability assessment of the advanced treatment of industrial wastewater  
28 is described here, which uses a combined analytical methodology consisting of event tree, fault  
29 tree and fuzzy logic theory. Here, it is assumed that this methodology is used for industrial

1 advanced wastewater treatment systems which followed by other treatment process. In this  
2 situation, entered wastewater/influent into ATUs is previously treated by secondary treatment  
3 processes.

4 Generally, the framework as shown in Fig. 1 comprises three major steps of inputs, reliability  
5 assessment and outputs. The first step entails identifying alternatives of hybrid ATU systems and  
6 specifying assessment criteria in accordance with rational options and national regulations/targets.  
7 The data required in this step are collected based on the documents related to historic performance  
8 of advanced wastewater treatment provided by stakeholders and/or available in the literature. A  
9 single alternative is defined here as a combination of multiple units in advanced treatment (Fig. 2)  
10 which can provide treated wastewater in accordance with desirable water quality for industrial  
11 reuse purposes (e.g. boilers and cooling towers in factories).

12 The second step consists of reliability assessment of each alternative using a combination of  
13 fault tree and event tree analyses. More specifically, the event tree first provides a list of all  
14 possible scenarios of performance for each alternative based on different combinations of success  
15 and failure states of each ATU in the alternative. For each alternative, event tree analysis then  
16 identifies "acceptable scenarios" which is defined for a scenario when the water quality of the  
17 treated effluent in the hybrid ATU systems is within standard limits based on the assessment  
18 criteria defined in Step 1.

19 The fault tree analysis is then applied to specify the failure probability of each ATU  
20 individually by using fuzzy logic technique and experts' judgement. This can be used to calculate  
21 the failure probability of all ATUs in each alternative and after defuzzification of failure  
22 probability, crisp number can be used to calculate the failure probability of each scenario in event  
23 tree analysis. Details of the terms, methods and assumptions used in each step are further described  
24 in the following subsections.

25

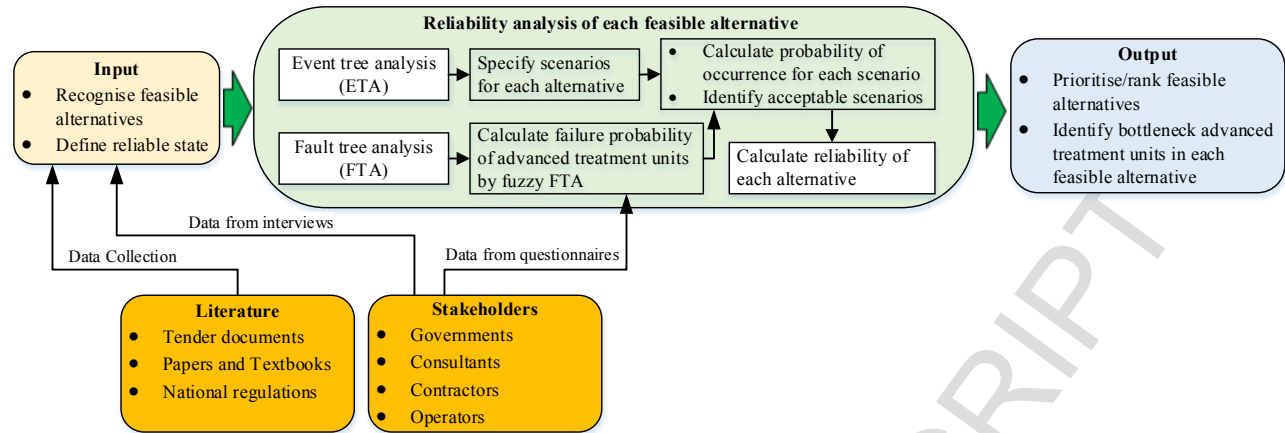

Fig. 1 Suggested framework for the reliability assessment of ATUs

## 2.2 Feasible alternatives

Numbers of feasible alternatives are specified here for reliability assessment. Each alternative is a combination of  $n$  advanced treatment units as shown in Fig. 2. Feasible alternatives of industrial wastewater treatment can generally be introduced based on the scale used for treatment such as individual, decentralised, cluster, satellite and centralised systems. Centralised WWTP is more recommended for industrial wastewater in developing countries compared to other scales due to their advantages in some criteria such as economic and ease of management (Piadeh *et al.*, 2014; Üstün *et al.*, 2011). Centralised WWTP generally includes primary and secondary treatment, which can provide treated wastewater for non-potable water reuse without a high-quality standard. However, advanced treatment is necessary in order to provide treated wastewater for discharge into receiving water bodies.

Two general approaches can be considered for advanced treatment of the secondary effluent. The first approach adopts the treatment of the entire secondary effluent but it may need a large capital investment. This seems to be a less attractive option for developing countries that may suffer from lack of sufficient economic resources (Adewumi *et al.*, 2010). Alternatively, the second approach considers a blending system (Piadeh *et al.*, 2014) in which only a small proportion of the secondary effluent is first treated by ATUs and then is blended with the remained secondary effluent (Fig. 2). The industrial wastewater treatment analysed here is following the second



1 approach, i.e. the treated wastewater discharged into receiving water is a combination of secondary  
 2 and advanced treated effluent.

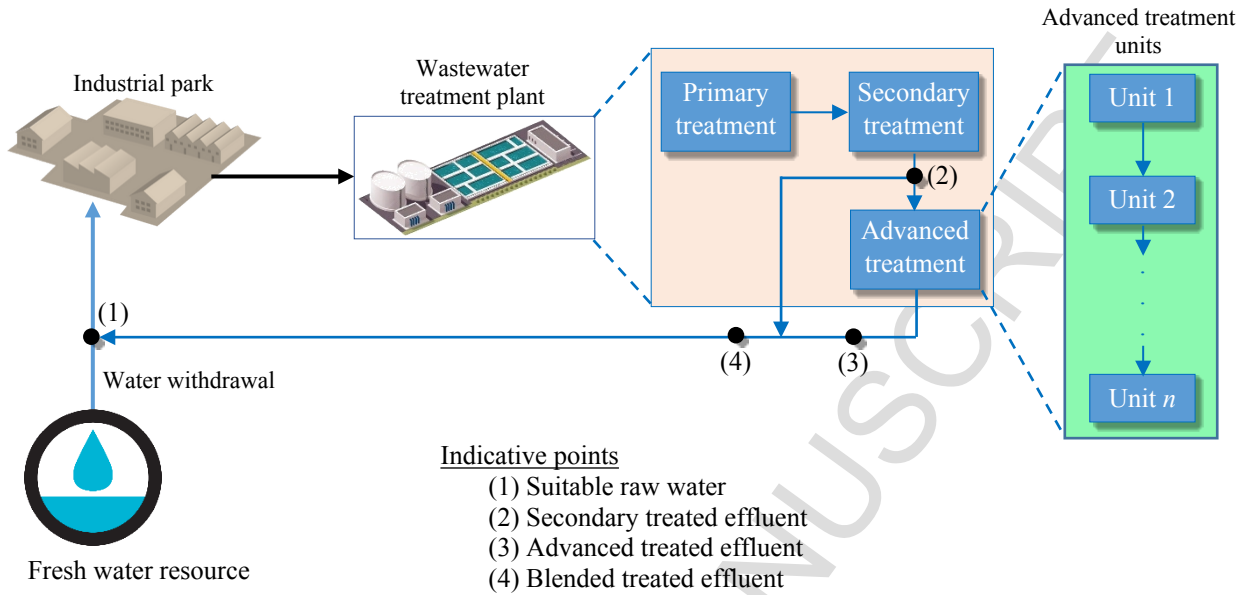

3  
 4 **Fig. 2 Schematic flow-diagram of a typical industrial wastewater treatment**

### 5 **2.3 Acceptable state analysis**

6 Based on the success or failure function of each ATU, the performance of a feasible alternative  
 7 can be evaluated in different scenarios based on the water quality of the treated effluent. Hence,  
 8 the performance of a feasible alternative with a series of ATUs is called acceptable if the treated  
 9 effluent (i.e. point 4 in Fig. 2) is within standard limits of water quality under specified conditions  
 10 during a given period (Bourouni, 2013). The assessment requires that for each of the  $n$  units in an  
 11 alternative, a specific removal efficiency for each pollutant is first specified. For example, in the  
 12 series of  $n$  units shown in Fig. 3, Unit 1 receives the secondary effluent with pollutant concentration  
 13  $j$  ( $C_{1j}$ ) and reduces the concentration by specific removal efficiency ( $X_{1j}$ ) and finally discharge the  
 14 treated effluent with pollutant concentration  $j$  ( $C_{2j}$ ) which is the input of the following unit. As  
 15 such, the treatment by-product with pollutant concentration  $j$  ( $R_{1j}$ ) is also extracted from Unit 1.  
 16 The treatment process continues sequentially until the last unit (Unit  $n$ ) in which the advanced  
 17 treated effluent is blended with secondary treated effluent to account for the overall blended  
 18 effluent. Concentrations of pollutants of the treated effluent are compared with standard limits to  
 19 evaluate the acceptable state of the alternative. The concentrations of all pollutants in point 4,

1 which are checked against standard limits, specify whether the treatment process of the analysed  
 2 scenario in the alternative is acceptable or not. For the case of malfunction/fault of a unit, the  
 3 resultant discharge of that faulty unit has no impact on declining pollutants concentration and  
 4 hence the following units have to undertake treatment to reach the standard limits. The various  
 5 cases of malfunction in treatment units create a set of scenarios (events) with different  
 6 combinations of malfunction in units. It should be noted that reliability of each scenario needs to  
 7 be analysed separately. The reliability state of these scenarios for each alternative can be identified  
 8 by using event tree and fault tree analyses, which are described, in the following sections.

9 Here, as was mentioned, it is assumed that entered wastewater/influent into ATUs is treated by  
 10 secondary treatment processes. Consequently, pollutants concentration of secondary's effluent is  
 11 the same for all hybrid system alternatives and the removal efficiency of pollutants for each unit  
 12 is constant. Additionally, for a better comparison,  $C_{1j}$  (effluent of secondary treatment) and  
 13 discharge rate are assumed to be similar for all analysed alternatives.

14

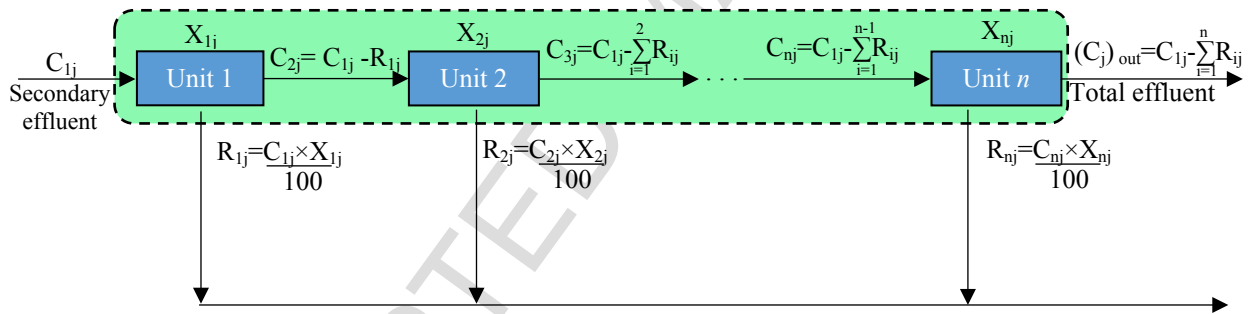
**Legend**

$C_{ij}$	Influent concentration of pollutant $j$ in unit $i$ (mg/L)
$X_{ij}$	Removal efficiency of pollutant $j$ related to unit $i$ (%)
$R_{ij}$	Removed concentration of pollutant $j$ by unit $i$ (mg/L)
$(C_j)_{out}$	Final concentration of pollutant $j$ in treated wastewater (defined as a state)

15

16

**Fig. 3 Schematic mechanism of pollutant removal in a series of ATUs**

## 17 2.4 Event tree analysis

18 Event tree analysis (ETA) is used here to calculate the reliability of each alternative. The ETA  
 19 is essentially an inductive logic method to identify various sequences of events and is able to  
 20 calculate the related probability of occurrence (Abdelgawad and Fayek, 2012). More specifically,  
 21 Fig. 4 represents the general structure of the ETA for an alternative. This is comprised of multiple

1 branches (i.e. scenarios) as a sequence of possible success/failure events for successive units. In  
 2 fact, the event tree needs to enumerate all sets of possible success (i.e. unit functioning correctly)  
 3 and failure (i.e. unit malfunction/faulty) states of each unit with a probability of S and F,  
 4 respectively. It assumed that, each top event of a fault tree allows the evaluation of the failure state  
 5 (F) which is equal to  $S=1-F$ . The computed values of S and F are conditional probability of the  
 6 occurrence of an event given that events preceding that event have accrued while probability of  
 7 occurrence of events is independent due to constant rate of removal efficiencies of units. It should  
 8 be noted that for a series of  $n$  treatment units, a total of  $2^n$  different scenarios can be envisaged.  
 9 Probability of occurrence for each scenario (i.e. in a sequence) is equal to multiplication of  
 10 occurrence probabilities of states (either success or failure) for all units in the sequence as shown  
 11 in Fig. 4 (Zio, 2007). The secondary wastewater effluent is the initiating event assuming that  
 12 always happens (i.e. probability of 100%) and thus its impact is neutralised in the occurrence  
 13 probability of scenario. Thus, different states of each unit operation representing in multiple  
 14 branches make up all scenarios for one alternative. The acceptable state analysis described in the  
 15 previous section is carried for all scenarios to identify acceptable scenarios in each alternative. The  
 16 reliability of an alternative is finally calculated by aggregating the probability of acceptable  
 17 scenarios only as (Zio, 2007):

$$\text{Reliability of an alternative} = \sum P(\text{acceptable scenarios}) \quad (1)$$

18

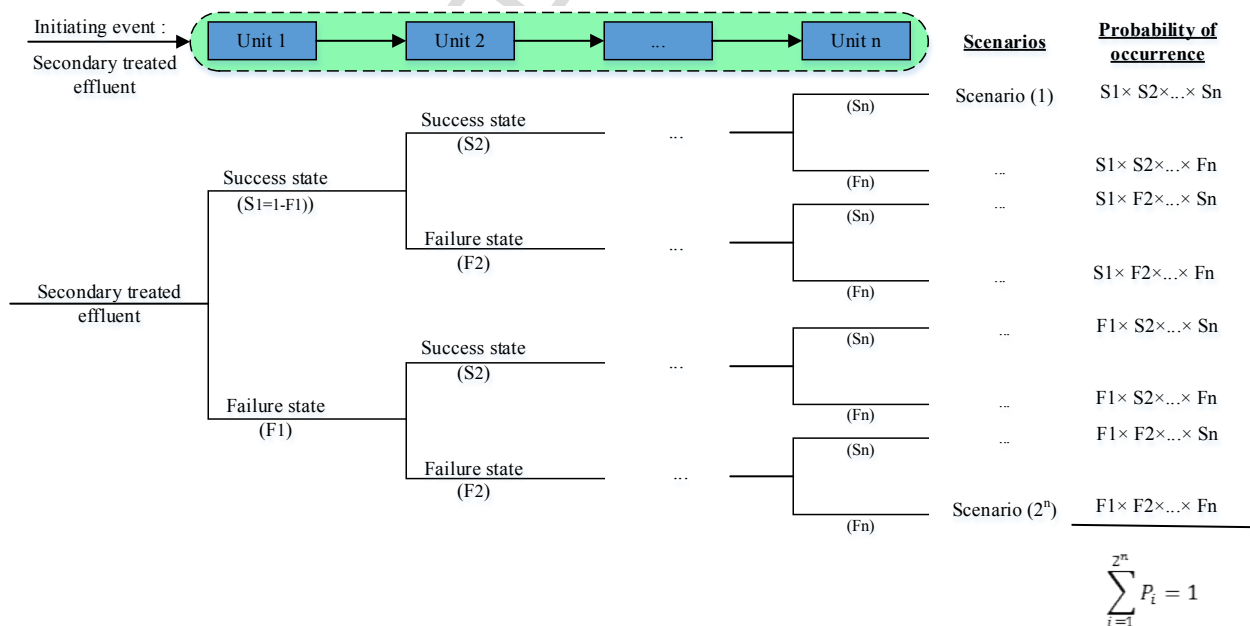

19

1  
2

**Fig. 4 Scenario-based ETA suggested for an alternative**

ACCEPTED MANUSCRIPT

## 1 2.5 Fault tree analysis

2 Fault tree analysis (FTA) is used here to estimate the likelihood/ probability of failure (F) for each  
 3 ATU, which will be then employed in ETA for reliability analysis of alternatives. More  
 4 specifically, the likelihood of a top event in FTA is the failure probability of a ATU which can be  
 5 considered for evaluation of the occurrence probability for that event in ETA (Zio, 2007). A typical  
 6 FTA schematically shown in Fig. 5 is structured in three levels: (1) top events (TE) located in the  
 7 highest level; (2) intermediate events (IE) located in the intermediate levels and (3) base events  
 8 (BE) contributed in the lowest level. Events in each level is connected with related upper level  
 9 events by two major logical gates of 'OR' and 'AND'. The OR gate describes the upper event will  
 10 occur once one of its lower level events is occurred while the AND gate will occur only when all  
 11 connected lower level events occur simultaneously (Nývlt *et al.*, 2011). Thus, the probability of  
 12 occurrence ( $P$ ) of an upper level event can be calculated based on probability of occurrence of  
 13 connected lower level events as (Abdelgawad and Fayek, 2012):

$$P(\text{upper level event}) = \begin{cases} 1 - \prod_{i=1}^n [1 - P(\text{lower level event}_i)] & \text{for 'OR gate'} \\ \prod_{i=1}^n P(\text{lower level event}_i) & \text{for 'AND gate'} \end{cases} \quad (2)$$

14 where  $n$  =total number of lower level events connected to the upper level event; and  $P$  =probability  
 15 of occurrence. Also, note that all the events in the same level linked to one upper level event are  
 16 mutually exclusive. A bottom up approach is used to calculate first the probability of occurrence  
 17 for intermediate level events based on those in base events. The probability of occurrence at the  
 18 top-level event is then calculated accordingly which will be used in ETA as the failure probability  
 19 of ATU.

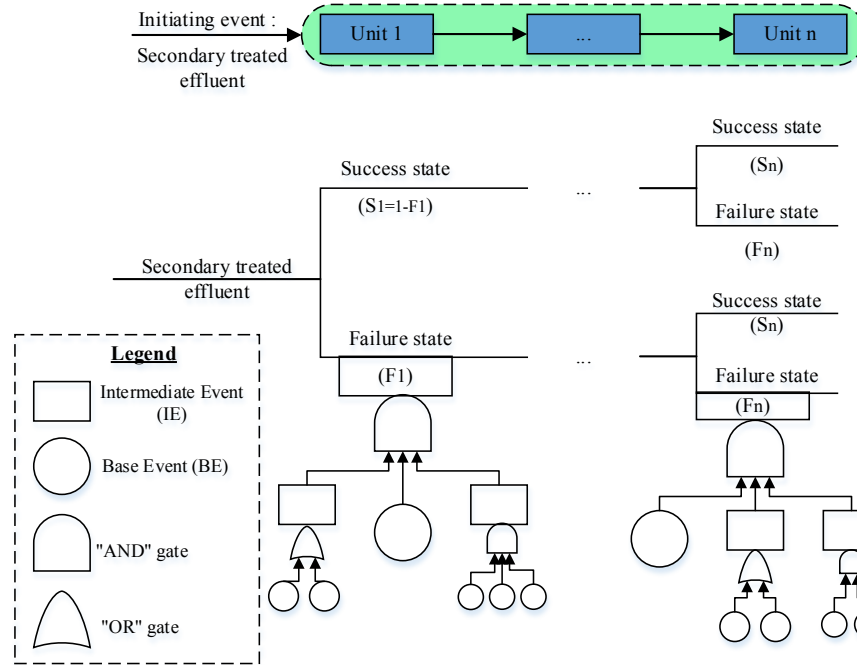

1  
2

**Fig. 5 Schematic fault tree analysis for evaluation of the failure probability of an event**

### 2.5.1 Fuzzy FTA

FTA requires the performance data for the failure probability of base events (BE) in ATUs. Such data for ATUs are unlikely to be available especially in developing countries. To overcome the challenge of lack of data, the probability of occurrence of base events is determined here by experts' judgement. Both fuzzy logic and grey logic can be applied to quantify expert's judgement. However, this study uses fuzzy logic as for grey logic, there is no particular probability for values between intervals assigned to subjective judgements whereas the fuzzy logic allows the languid transition between different concepts through the use of fuzzy membership functions which depict the linguistic terms of experts describing their concepts (Abdelgawad and Fayek, 2012)

Fig. 6 represents the suggested framework of the fuzzy FTA comprising of six major steps, which are used here to calculate failure probability of each ATU. Step 1 entails defining linguistic variables and associated fuzzy membership functions for failure probability of BEs in five terms (i.e. very high (VH), high (H), medium (M), low (L), very low (VL)). The membership functions can be obtained based on experts' opinion (Rajakarunakaran *et al.* 2015).

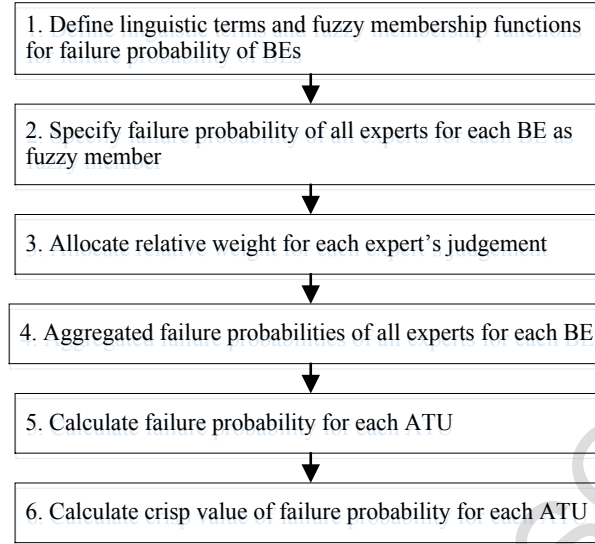

Fig. 6 Suggested framework in the fuzzy FTA

Failure probability of each BE is then specified as fuzzy membership functions in step 2. This is carried out through questionnaires or interviews with experts using linguistic terms of experts' judgements. The failure probabilities of each BE specified by the judgement of different experts need to be combined into a single failure probability by using the  $\alpha$ -cut method in step 4 (Ahmadi *et al.*, 2016). Before this, a relative weight is also allocated for the judgement of each expert in step 3 based on the personal characteristics of the expert including job title, experience (service time) and educational level (see Table 4 in case study for instance) (Yuhuaa and Dataob, 2005). The relative weight of each expert is calculated by dividing the sum of the scores of the expert by sum of the scores of all experts.

The single fuzzy number of the failure probability of base event  $i$  ( $BE_i$ ) aggregated for all experts is calculated by the following linear relationship:

$$P(BE)_i = \sum_{j=1}^n W_j * P(BE)_{ij} \quad (3)$$

where  $P(BE)_{ij}$  = probability of event  $i$  ( $BE$ ) $_i$  by expert  $j$  (fuzzy number);  $W_j$  =relative weight of expert  $j$  (real number); and  $n$  =number of experts. The fuzzy number of the failure probability for each ATU is then calculated according to Eq. (2) by using the  $\alpha$ -cut method in step 5 (Ahmadi *et al.*, 2016). In the  $\alpha$ -cut method, each fuzzy function for BEs is represented using the  $\alpha$ -cuts. The

1  $\alpha$ -cut of fuzzy function A is the set of all x values in the set for which the membership degree in  
 2 the fuzzy function is greater than or equal to the alpha argument (Abdelgawad and Fayek, 2012).  
 3 For mutually exclusive events, if probability of lower level events of a TE or IE is represented by  
 4  $\alpha$ -cut as  $[a_i, b_i]$ , based on Eq. (2) and  $\alpha$ -cut principles, the  $\alpha$ -cut of the fuzzy probability of upper  
 5 level even (a TE or IE) connected by an OR gate or by an AND gate is defined in Eq. (4):

$$FP(\text{upper level event})^\alpha = \begin{cases} 1 - \prod_{i=1}^n [1 - a_i, 1 - b_i] & \text{for 'OR gate'} \\ \prod_{i=1}^n [a_i, b_i] & \text{for 'AND gate'} \end{cases} \quad (4)$$

6 Note that in the multiplication operator, if  $A^\alpha = [a_1, b_1]$  and  $B^\alpha = [a_2, b_2]$  be  $\alpha$ -cuts for fuzzy  
 7 functions of A and B, respectively, then:

$$A^\alpha \times B^\alpha = [\min(a_1 a_2, a_1 b_2, a_2 b_1, b_1 b_2), \max] \quad (5)$$

8 Finally, the fuzzy number related the failure probability for each ATU is converted into a crisp  
 9 value (defuzzification) by using centre of gravity (COG) technique in step 6 (Ardeshir *et al.*, 2014).  
 10 Steps 5 and 6 are further elaborated when the case study is described in the next section.

### 11 **3 Case study description**

12 The proposed framework is demonstrated here by its application to real case studies of hybrid  
 13 ATU system of industrial wastewater in Iran. The case studies are located in semi-ared geography  
 14 of Iran, where fresh water resources are very limited and sometime insufficient for meeting the  
 15 water demands especially industrial demands. Therefore, industrial wastewater reuse as a clean  
 16 production is a sustainable solution due to both preventing the entrance of polluted industrial  
 17 wastewater to receiving water bodies and compensating the gap between water demand and  
 18 supply. Industrial wastewater treatment systems for reuse purposes is currently of limited use in  
 19 Iran and generally in small scale compared to total produced wastewater (ISIPO, 2016). More  
 20 specifically, only about 4.1% of secondary wastewater of the total industrial effluent (6,390 out of  
 21 156,500 m<sup>3</sup>/day) are currently treated in the industrial ATUs in Iran while it is expected that this  
 22 rate increases by about 2% annually (ISIPO, 2016).



1 Currently, there are 6 industrial parks equipped with hybrid ATU systems in Iran.  
 2 Specifications of all these cases were used here as feasible alternatives of hybrid ATU system  
 3 (Table 2). Other feasible alternatives include those suggested by relevant consultancies (approved  
 4 by verified GPEX software) for future developments in other industrial parks (ISIPO, 2016). These  
 5 suggested alternatives are the results of the rigorous scrutiny of potential ATU systems. All this  
 6 results in 15 feasible alternatives made up of hybrid ATU systems (Table 2) that can be installed  
 7 for industrial treatment in Iran (ISIPO, 2016). Each alternative representing an industrial WWTP  
 8 includes a series of between 4 and 5 physical and/or chemical process units coupled with  
 9 membranes. The name of existing alternatives of wastewater treatment and their location (province  
 10 name in Iran) are given in Table 2. They are located in central (Semnan and Qom provinces) and  
 11 southern (Bushehr province) part of Iran where fresh water resources are limited.

12 **Table 2 Feasible alternatives of the ATUs of industrial wastewater**

Alternative	Process Units					Name of industrial park / province				
	Unit 1	+	Unit 2	+	Unit 3		+	Unit 4	+	Unit 5
A1	DAF <sup>1</sup>		O <sub>3</sub> <sup>2</sup>		MF <sup>3</sup>		AC <sup>4</sup>		RO <sup>5</sup>	Bushehr / Bushehr
A2	MBBR <sup>6</sup>		MBR <sup>7</sup>		AC		RO		-	SFD <sup>13</sup>
A3	Pre. <sup>8</sup>		O <sub>3</sub>		AC		MF		RO	SFD
A4	SF <sup>9</sup>		AC		MF		UF <sup>10</sup>		RO	SFD
A5	SF		MBBR		MBR		RO		-	SFD
A6	SF		MBR		AC		RO		-	Shokuhiye / Qom AQ qala / Semnan Semnan / Semnan
A7	SF		MBR		UF		RO		-	Mobarake / Isfahan
A8	SF		MF		AC		RO		-	Murche Khurt / Isfahan
A9	SF		UF		AC		RO		-	SFD
A10	C&F <sup>11</sup>		O <sub>3</sub>		AC		MF		RO	SFD
A11	SF		MBR		O <sub>3</sub>		AC		IE <sup>12</sup>	SFD
A12	SF		AC		MF		UF		IE	SFD
A13	SF		UF		AC		IE		-	SFD
A14	SF		MBBR		MBR		IE		-	SFD
A15	SF		MBR		UF		IE		-	SFD

1: Dissolved air flotation

2: Ozonation

3: Micro filter

4: Activated carbon

5: Reverse osmosis

6: Moving bed biofilm reactor

7: Membrane bioreactor

8: Precipitation

9: Sand filter

10: Ultra filter

11: Coagulation and flotation

12: Ion exchange

13: Suggest for future developments

1 They are made up of different combinations of 12 ATUs with the range of their removal  
 2 efficiencies in Table 3 and average values (Ave) used here as  $X_{ij}$  in Fig. 3. Obviously, removal  
 3 efficiency of each unit is dependent on the rate and quality of influent wastewater (design  
 4 parameters) as well as position of unit in hybrid system. For this purpose, design parameters of the  
 5 secondary effluent of all units are considered as a discharge rate of 300 m<sup>3</sup>/day along with three  
 6 pollutants of chemical oxygen demand (COD) of 270 mg/L, total suspended solid (TSS) of 140  
 7 mg/L and total dissolved solid (TSS) of 2300 mg/L. Due to lack of local data, the range of removal  
 8 efficiencies were collected from literature reported in 36 case studies between 2007 and 2016 (see  
 9 further details in appendix A). Also, note that only the last ten years of the literature was used due  
 10 to fast progress of intensive improvement of treatment technologies. Although removal efficiency  
 11 of an ATU may change depending on its position in the treatment chain, the average data are only  
 12 considered here. Additionally, these three pollutants are used here for state control with the  
 13 following limits in advanced treated effluent: COD=10 mg/L, TSS=5 mg/L and TDS=100 mg/L  
 14 (Piadeh *et al.*, 2014).

15 **Table 3 Removal efficiency of the ATUs**

Unit	COD removal (%)		TSS removal (%)		TDS removal (%)	
	Range <sup>1</sup>	Ave	Range <sup>1</sup>	Ave	Range <sup>1</sup>	Ave
DAF	65.71-80.3	74.70	74-92	83.36	29.08-96	62.54
Per.	26.72-76.7	55.61	93.6-96	94.80	1.6	1.60
C&F	67.80-95	76.68	83-99.85	85.39	16.75-35	22.15
MBBR	57.7-96.98	77.93	85	85.00	10	10.00
MBR	87.7-99.9	94.61	97.84-99.8	99.03	7.34-18.3	9.15
O <sub>3</sub>	55-89	69.75	18-23.5	20.99	18	18.00
SF	32.08-94	68.36	58.33-90	74.84	25-31	28.00
MF	71.43-95.42	81.01	81-99	88.89	1-3.25	1.56
UF	56.46-99.2	82.43	94.14-100	81.16	0.3-3.71	1.95
AC	62.32-97.4	84.19	72.73-97.59	85.16	0.79-22.3	11.55
IE	51.76-93.4	75.68	97.1-99.85	99	97.7-99.53	98.68
RO	77.99-98	91.04	94.12-98.5	97.03	87.54-98.18	94.45

<sup>1</sup> The range of removal efficiency reported in the literatures (See Table A.1 in Appendix A)

16 The fault tree used here for FTA of each ATU is constructed based on the interview with a  
 17 number of experts. Base of the interview, fault trees for all units are constructed similarly as shown  
 18 in Fig. 7 comprising 9 intermediate events, 21 base events with the details given in Table 4.

1 According to the conducted fault tree, the ATU failure can be due to five main causes including  
 2 (1) undesired secondary effluent; (2) Failure of pipes and joints; (3) failure of energy sources; (4)  
 3 failure of equipment and (5) failure of valves and gates. The event of undesired influent to ATUs  
 4 can be linked to water quality and overflow issues in base events. Other ATU failures can be  
 5 originated from infrastructure problems related to its design, construction, operation and  
 6 maintenance.

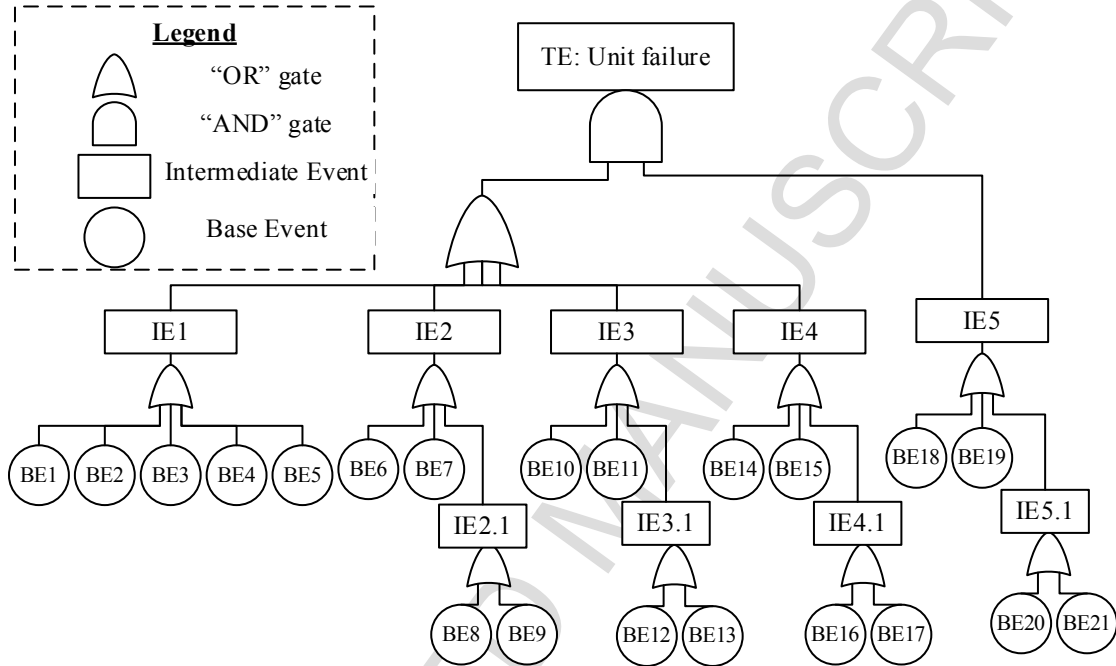

7  
8 **Fig. 7 Structure of FTA of ATUs in the case study**  
9

10 According to the constructed fault tree in Fig. 7, the ATU failure (i.e. top event) can be  
 11 summarised to combination of base events by using of Boolean algebra and considering OR ( $\cup$ )  
 12 and AND ( $\cap$ ) gates as:

$$TE = (IE1 \cup IE2 \cup IE3 \cup IE4) \cap IE5 = \left( \bigcup_{i=1}^{17} BE_i \right) \cap \left( \bigcup_{i=18}^{21} BE_i \right) \quad (5)$$

13 By considering Eq. (2), the fuzzy probability (FP) of ATU's failure (TE) can be calculated  
 14 based on the fuzzy probability of base events' failure by using  $\alpha$ -cut method as:

$$FP(TE) = (1 - \prod_{i=1}^{17} (1 - FP(BE_i))) * (1 - \prod_{i=18}^{21} (1 - FP(BE_i))) \quad (6)$$

1  
2

**Table 4 Fault tree events of failure in the ATUs of the case study**

Code	Name	Description
TE	<b>Failure of a ATU</b>	-
<b>IE1</b>	<b>Undesired secondary effluent</b>	Entering secondary effluent with excessive undesired water quality into the ATU
BE1	Excessive COD	Entering secondary effluent with excessive concentration of COD
BE2	Excessive TSS	Entering secondary effluent with excessive concentration of TSS
BE3	Excessive TDS	Entering secondary effluent with excessive concentration of TDS
BE4	Improper pH	Entering secondary effluent with undesired pH (below the 7 or over 9)
BE5	Excessive Q	Entering excessive flow of secondary effluent
<b>IE2</b>	<b>Failure of pipes and joints</b>	Any problems in pipes and joints such as burst, leakage, breakage and blockage
BE6	Incorrect design	Improper design by the consultant
BE7	Incorrect construction	Improper construction or equipment by the contractor
IE2.1	Incorrect maintenance	Improper maintenance by the operator
BE8	Inappropriate maintenance	insufficient maintenance and inspection
BE9	Inefficient rehabilitation	Lack of timely replacement of equipment
<b>IE3</b>	<b>Failure of energy sources</b>	Any problems in pumps, power supply, generators
BE10	Incorrect design	Improper design by the consultant
BE11	Incorrect construction	Improper construction or equipment by the contractor
IE3.1	Incorrect maintenance	Improper maintenance by the operator
BE12	Inappropriate maintenance	insufficient maintenance and inspection
BE13	Inefficient rehabilitation	Lack of timely replacement of equipment
<b>IE4</b>	<b>Failure of equipment</b>	Any problem in accessories and equipment of the ATU
BE14	Incorrect design	Improper design by the consultant
BE15	Incorrect construction	Improper construction or equipment by the contractor
IE4.1	Incorrect maintenance	Improper maintenance by the operator
BE16	Incorrect maintenance	Insufficient maintenance and inspection

Code	Name	Description
BE17	Inappropriate maintenance	Lack of timely replacement of equipment
<b>IE5</b>	<b>Failure of valves and gates</b>	Any problem in control valves and gate
BE18	Incorrect design	Improper design by the consultant
BE19	Incorrect construction	Improper construction or equipment by the contractor
IE5.1	Incorrect maintenance	Improper maintenance by the operator
BE20	Inappropriate maintenance	insufficient maintenance and inspection
BE21	Inefficient rehabilitation	Lack of timely replacement of equipment

1

2 By constructing fault tree, linguistic terms and associated fuzzy membership functions for  
3 failure probability of BEs are defined based on experts' opinion as shown in Fig. 8. Note that, in  
4 experts' opinion in this case, the failure probability of BEs is limited to 20.

5

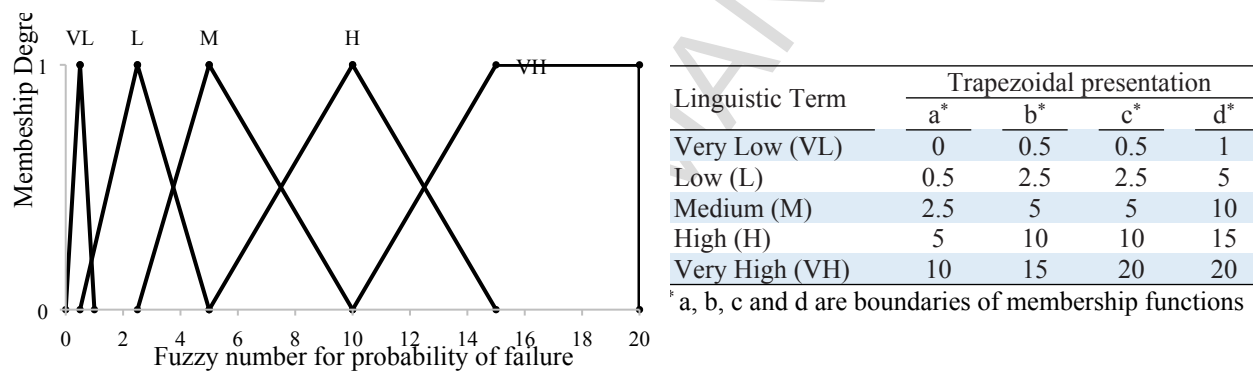

6

7 **Fig. 8 Linguistic terms and fuzzy membership functions used for failure probability of base events**

8 To combine different experts' judgements on each BE into a single failure probability by using  
9 of experts' relative weight, a scoring system is proposed based on the characteristics of experts  
10 including job title, experience (service time) and educational level as shown in Table 5. The  
11 relative characteristics used in the Table are based on the suggestions made by Yuhuaa and Dataob  
12 (2005) and scores are obtained by experts' judgments.

13

1

**Table 5 Scores of experts' characteristics**

Expert's characteristics	Score
Job title (Range: 1-3):	
• Ministry of industry*:	
- Manager in central organisation	2
- Manager in state organisation	1
• Consultant:	
- Manager	3
- Designer	1
• Contractor:	
- Manager	3
- Field operator**	1
• Operators***:	2
Educational level (1-3):	
- Diploma or lower	1
- B.Sc.	2
- M.Sc.	2.5
- Ph.D.	3
Service time (1-2):	
<5 years	1
>5 years	2
* Responsible for providing the financial budget, and supervision during the operation	
**Responsible for constructing and also 1-year operating system as a temporary delivery	
***Hired by board of trustees for operating the system	

## 2 4 Results and discussion

3 The methodology is applied here for reliability assessment of 15 feasible alternatives of ATU  
4 systems proposed for industrial parks in Iran. The fuzzy FTA is first developed and analysed for  
5 ATUs based on experts' judgements. More specifically, the failure probabilities for each of 12  
6 ATUs are determined separately by using the linguistic terms defined by experts. A total of 15  
7 related experts consisting of governmental managers, consultants, contractors, and operators  
8 contributed to the questionnaire to evaluate and specify the failure probabilities of base events for  
9 each ATU. For example, the linguistic terms of failure probabilities of 21 base events specified by  
10 15 experts and their relative weights (steps 2 and 3 in Fig. 6) for activated Carbon unit only are

1 illustrated in Table 5. This table also shows the single aggregated fuzzy number of failure  
2 probabilities first for each base event (step 4 in Fig. 6) using Eq. (3) and finally for top event (step  
3 5 in Fig. 6) using Eq. (6) for this ATU as a result of the fuzzy FTA. Corresponding tables for other  
4 ATUs are also developed similarly.

5 Fig. 9 shows the fuzzy numbers of failure probability for all 12 ATUs obtained from FTA as  
6 described in Table 6 and the  $\alpha$ -cut method. The crisp values of failure probabilities of ATUs  
7 obtained by defuzzification are also shown ( $P^*$ ) in the figure (step 6 in Fig. 6). As can be seen,  
8 RO, O<sub>3</sub> and IE units face the highest failure probability with 30%, 24% and 22%, respectively,  
9 while C&F has the lowest failure probability (5.4%). The relative rates of the failure probability  
10 rates calculated in the figure were approximately confirmed by the experts who participated in the  
11 questionnaire. Akhoundi and Nazif (2018) showed that RO unit can have considerable negative  
12 effect on reliability of hybrid systems. This can verify the highest failure probability of RO  
13 obtained in this study. As previously reviewed in the literature review, prior researches about the  
14 reliability of ATUs are limited as reliability assessment was more investigated for secondary  
15 treatment units. However, those who evaluated reliability in ATUs reported reliability for MBR  
16 system between 30% (Arroyo and Molinos-Senante, 2018) and 100% (Kalbar *et al.*, 2012) which  
17 can be related to special conditions of those case studies (e.g. age of unit, influent quality,  
18 manufacturing of MBR and etc.). Comparing the reliability of ATUs obtained in this study with  
19 those in literature show that MBR obtained in this study (82.38%) is close to Kalber *et al.* (2012)  
20 although their reliability (i.e. 100%) is too optimistic and hence cannot be realistic.

21 According to the experts' judgements, the high rate of failure probability in RO and O<sub>3</sub> can be  
22 attributed to the high failure probability of base events related to equipment (IE4) and valves and  
23 gates (IE5). Therefore, in order to reduce the failure probability of these units, the failure rates of  
24 the base events related to these intermediate events should be reduced.

25

Table 6 Linguistic terms and integrated fuzzy numbers of failure probability for base events of Activated Carbon unit in FTA

No of base event	Number of experts															FP(BE)*	FP(TE)**
	1	2	3	4	5	6	7	8	9	10	11	12	13	14	15		
	Relative weight of expert																
	0.0692	0.0755	0.0755	0.0629	0.0566	0.0692	0.0881	0.0440	0.0629	0.0629	0.0629	0.0629	0.0629	0.0818	0.0629		
Expert's judgment																	
1	L	L	M	M	L	M	L	M	M	L	M	L	M	L	H	(1.66,4.07,4.07,7.83)	
2	L	L	M	H	M	L	L	L	VL	H	VL	L	M	L	M	(1.52,3.84,3.84,7.04)	
3	L	M	L	M	L	VL	M	M	M	L	L	L	M	VH	L	(2.03,4.37,4.78,7.93)	
4	VH	L	L	VH	H	M	VH	H	M	H	L	VL	M	H	M	(4.18,7.61,8.71,11.79)	
5	M	VL	L	L	H	VL	L	L	L	M	M	L	M	L	L	(1.20,3.28,3.28,6.27)	
6	M	M	M	L	L	VL	L	H	M	H	H	VH	H	H	M	(3.17,6.37,6.69,10.54)	
7	M	H	M	L	VH	VL	M	L	M	L	L	H	VH	H	H	(3.47,6.71,7.31,10.82)	
8	H	H	H	H	H	L	M	M	M	VH	H	H	L	VL	H	(3.82,7.57,7.89,11.87)	
9	M	M	L	H	L	VL	L	VH	H	L	M	M	M	M	M	(2.41,5.05,5.27,9.03)	
10	M	L	M	VL	H	M	L	H	H	M	H	VH	M	H	H	(3.49,6.79,7.10,11.10)	
11	M	M	H	H	H	M	M	L	H	L	L	L	VL	L	H	(2.51,5.53,5.53,9.46)	
12	M	M	L	L	M	H	H	VL	L	VH	L	H	H	H	M	(3.25,6.59,6.90,10.73)	
13	M	M	M	M	M	H	H	M	L	H	VL	VL	M	L	L	(2.32,5.02,5.02,8.93)	
14	H	L	M	VL	M	L	H	M	M	M	L	H	L	M	L	(2.22,4.98,4.98,8.87)	
15	H	M	M	L	M	H	VL	VH	L	M	M	M	H	L	M	(2.69,5.53,5.75,9.61)	



16	H	M	L	H	M	M	L	H	L	H	L	L	H	H	M	(2.75,6.04,6.04,10.16)
17	M	L	M	H	H	M	VL	M	L	L	L	L	L	M	L	(1.67,4.07,4.07,7.54)
18	M	L	L	VL	VL	H	H	H	M	M	M	L	L	L	M	(1.99,4.57,4.57,8.14)
19	M	M	M	M	L	L	H	VH	H	M	L	M	L	M	M	(2.70,5.56,5.79,9.94)
20	H	M	M	VH	M	H	M	L	L	L	M	M	VH	L	L	(3.16,6.16,6.79,10.38)
21	M	L	M	M	L	M	H	L	M	M	L	VL	H	H	L	(2.32,5.13,5.13,9.09)

FP(BE): fuzzy probability of base event

FP(TE): fuzzy probability of top event

ACCEPTED MANUSCRIPT

28

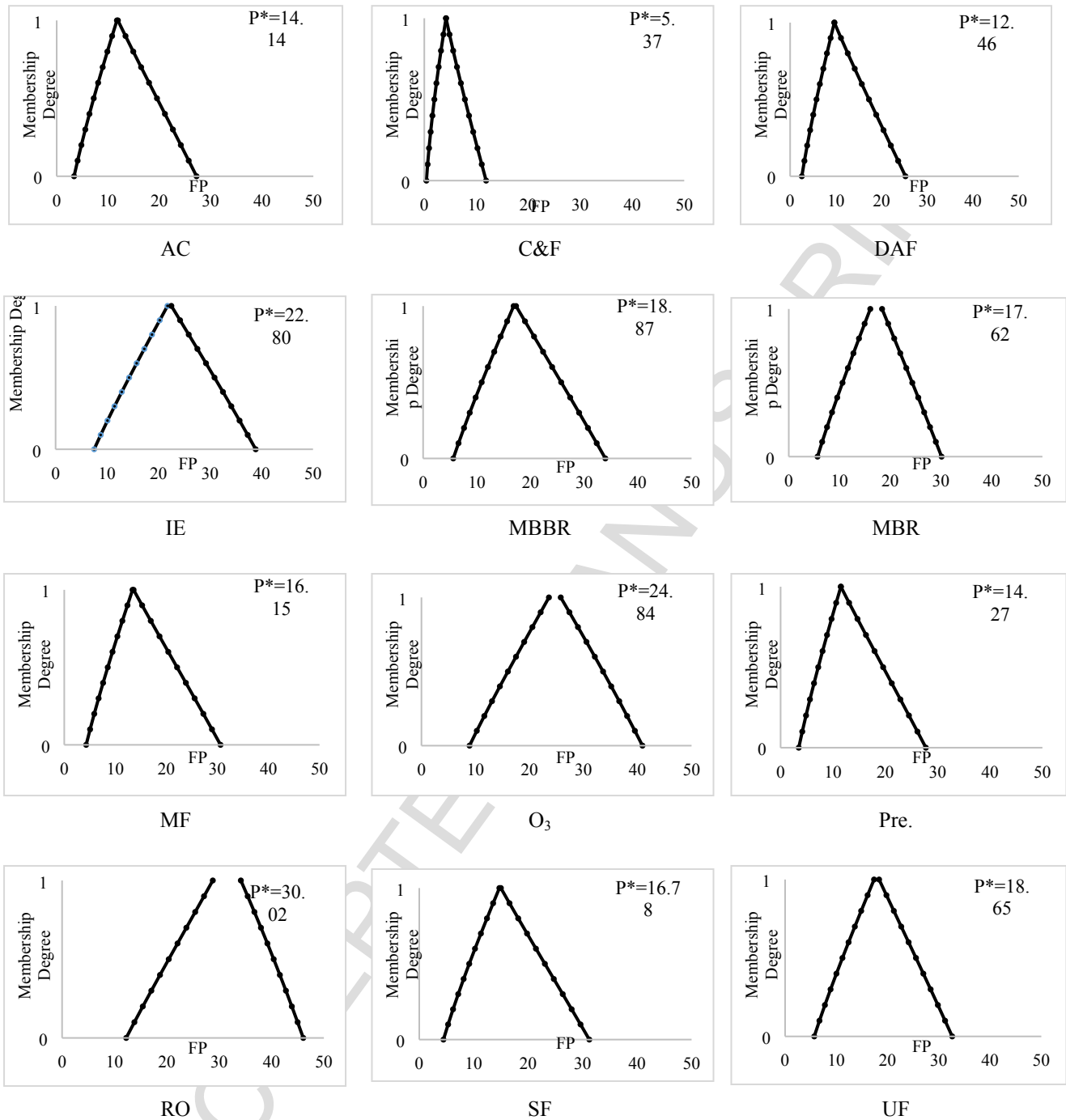

29

**Fig. 9 Fuzzy number of failure probability for the analysed ATUs**

30

31 By obtaining failure probability of each ATU as a crisp number, the reliability assessment of  
 32 each alternative is undertaken by ETA. This entails first specifying all scenarios and then

33 identifying scenarios in accordance with the state analysis defined earlier for water quantity of the  
34 treated effluence. For example, this procedure is illustrated in Table 7 for alternative A2 consisting  
35 of four ATUs (MBBR, MBR, AC and RO in sequence). As can be seen, out of 16 scenarios, only  
36 6 could satisfy all water quality requirements. This is mainly due to the violation of TDS since RO  
37 as the main contributor to TDS removal fails. After TDS, violations of TSS and COD are in most  
38 cases because of the failure in RO. It can be concluded that the RO functioning is vital for the  
39 operation of this alternative. Finally, the reliability of the alternative can be obtained by using Eq.  
40 (1) equal to 68.11% based on probabilities of acceptable scenarios. The value is mainly due to the  
41 high rate of scenario 1 (40%) which is the multiplication of success states in all units with high  
42 success probability rates. Similarly, a large proportion of overall reliability in other alternatives is  
43 dependent on success probability rates of all the units constituting those alternatives.

44 Reliability of other alternatives can be calculated similar to Table 7. Finally, ranking of 15  
45 analysed alternatives based on the reliability indicator is summarized in Table 8. The ranking  
46 indicates that alternatives of A12 (SF+AC+MF+UF+IE), A11 (SF+MBR+O3+AC+IE), and A10  
47 (C&F+O3+AC+MF+RO) are the most reliable hybrid ATU systems with 74.82%, 74.79%, and  
48 70.01%, respectively. The performance of reliability for the 3 top ranking alternatives (A12, A11  
49 and A10) is schematically illustrated in Fig 10 along with related units and their success  
50 probabilities. Although the average of individual units ( $S_{ave}$ ) is relatively similar from the highest  
51 to the lowest alternative, the changes of reliability values within this range is rather sensible.  
52 Moreover, it can be concluded that the alternatives with higher success probability rate in separate  
53 units (i.e.  $S_{ave}$ ) cannot necessarily result in a better reliability. For example, the reliability of A11  
54 is higher than A10 (74.8% compared to 70.0%) while  $S_{ave}$  of A10 is higher than A11. In addition,  
55 no specific relationship can be found between the highly ranked alternatives and specific individual  
56 units. This can also verify the paramount importance of the suggested reliability assessment  
57 methodology which needs to be conducted for the hybrid ATU systems. Moreover, the ranking  
58 shows that the five top ranked alternatives contain 5 units whereas alternatives with 4 units rank  
59 in the following. Although no strict correlation is observed between the number of units and higher  
60 reliability, this can indicate that alternatives with 5 units are likely to be ranked higher than those  
61 with 4 units.

Table 7 Reliability assessment of alternative A2 (MBBR+MBR+AC+RO)

No of scenario	Advanced Treatment Units								Effluent quality (mg/L) <sup>3</sup>			State of Scenario	P(Scenario) (%)	Reliability (%)
	MBBR		MBR		AC		RO		COD	TSS	TDS			
	State	Probability	State	Probability	State	Probability	State	Probability						
1	S <sup>1</sup>	0.81	S	0.82	S	0.86	S	0.70	<1	<1	92.3	✓ <sup>4</sup>	39.98	68.11
2	S	0.81	S	0.82	S	0.86	F	0.30	<1	<1	<b>1663.5</b>	✗ <sup>5</sup>	17.14	
3	S	0.81	S	0.82	F	0.14	S	0.70	<1	<1	99.8	✓	6.51	
4	S	0.81	S	0.82	F	0.14	F	0.30	3.2	<1	<b>1880.6</b>	✗	2.79	
5	S	0.81	F	0.18	S	0.86	S	0.70	3.8	<1	97.8	✓	8.78	
6	S	0.81	F	0.18	S	0.86	F	0.30	9.4	<b>10.8</b>	<b>1831.3</b>	✗	3.76	
7	S	0.81	F	0.18	F	0.14	S	0.70	5.3	<1	98.8	✓	1.43	
8	S	0.81	F	0.18	F	0.14	F	0.30	<b>59.6</b>	<b>21</b>	<b>2070</b>	✗	0.61	
9	F <sup>2</sup>	0.19	S	0.82	S	0.86	S	0.70	<1	<1	102.6	✓	9.38	
10	F	0.19	S	0.82	S	0.86	F	0.30	2.3	<1	<b>1848.3</b>	✗	4.02	
11	F	0.19	S	0.82	F	0.14	S	0.70	1.3	<1	<b>115.9</b>	✗	1.53	
12	F	0.19	S	0.82	F	0.14	F	0.30	<b>14.5</b>	1.4	<b>2089.6</b>	✗	0.65	
13	F	0.19	F	0.18	S	0.86	S	0.70	3.9	2.1	97.3	✓	2.06	
14	F	0.19	F	0.18	S	0.86	F	0.30	<b>42.7</b>	<b>72</b>	<b>2034.5</b>	✗	0.88	
15	F	0.19	F	0.18	F	0.14	S	0.70	<b>24.2</b>	4.2	<b>127.7</b>	✗	0.34	
16	F	0.19	F	0.18	F	0.14	F	0.30	<b>270</b>	<b>140</b>	<b>2300</b>	✗	0.14	

<sup>1</sup> S: Success state

---

<sup>2</sup> F: Failure state

<sup>3</sup> Those values violated the limits are highlighted in bold

<sup>4</sup> ✓: Acceptable scenario as all three water quality parameters are within the allowable ranges of the effluent quality.

<sup>5</sup> ✗: Unacceptable scenario as at least one of the three water quality parameters exceeds its allowable range of the effluent quality.

ACCEPTED MANUSCRIPT

64

**Table 8 Ranking of alternatives based on reliability**

Rank	Alternative No	Combination of alternative	Reliability (%)	S <sub>ave</sub> (%)
1	A12	SF+AC+MF+UF+IE	74.82	82.30
2	A11	SF+MBR+O3+AC+IE	74.79	80.76
3	A10	C&F+O3+AC+MF+RO	70.01	81.90
4	A1	DAF+O3+MF+AC+RO	68.42	80.48
5	A6	SF+MBR+O3+AC+RO	69.56	79.32
6	A9	SF+UF+AC+RO	68.32	80.10
7	A4	SF+AC+MF+UF+RO	68.32	80.85
8	A8	SF+MF+AC+RO	68.32	80.73
9	A2	MBBR+MBR+AC+RO	68.11	81.04
11	A5	SF+MBBR+MBR+RO	67.75	79.18
10	A3	Pre. + O3+AC+MF+RO	67.52	80.12
12	A7	SF+MBR+UF+RO	66.10	79.23
13	A14	SF+MBBR+MBR+IE	63.60	80.98
14	A15	SF+MBR+UF+IE	63.60	81.04
15	A13	SF+UF+AC+IE	53.92	81.91

65

66

67

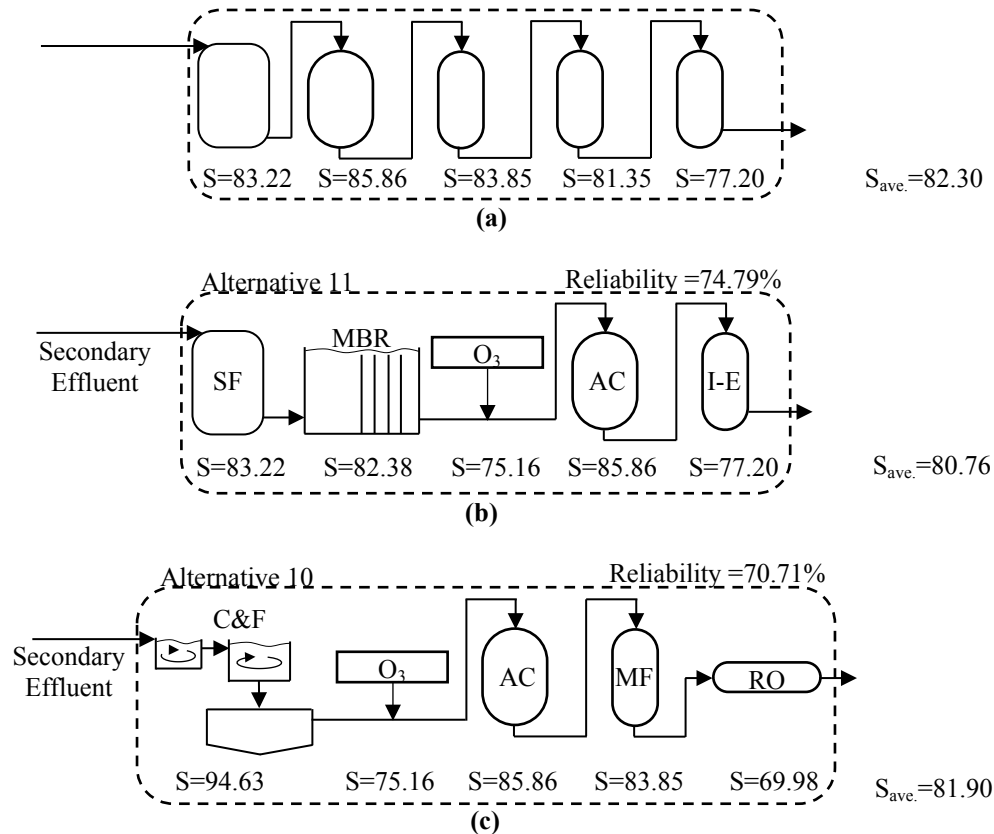

68

69 **Fig. 10 Schematic process of Prioritised alternatives and their reliabilities: a) Alternative**  
 70 **11, c) Alternative 10; note that S indicates the success probability of a unit**

71 Table 9 compares the ranking of alternatives with the relevant ranking for each removal  
 72 efficiencies of alternatives when all units of an alternative work properly. As shown in the table,  
 73 although A2 has the best removal efficiency in COD and TSS, it is ranked ninth based on reliability  
 74 of alternatives. Similarly, A11 with highest rank for TSS and TDS removal, the reliability rank of  
 75 the alternative is second. It implies that reliability-based ranking in ATU alternatives can be  
 76 independent from the performance of individual removal efficiencies even with high performance  
 77 for one or two parameters in an alternative.

78

79

**Table 9 Comparison of ranking of alternatives based on reliability vs removal efficiency**

Rank based on reliability	Alternative No	Removal efficiency and ranks when all units work properly					
		COD		TSS		TDS	
		% Removal	Rank	% Removal	Rank	% Removal	Rank
1	A12	99.03	11	100	1	99.19	3
2	A11	99.67	9	100	1	99.37	1
3	A10	99.70	1	99.98	10	96.91	7
4	A1	99.86	3	99.98	10	98.52	6
5	A6	99.82	3	99.98	10	98.52	6
6	A9	99.98	11	99.89	15	96.53	10
7	A4	99.94	3	99.99	8	96.59	9
8	A8	99.94	10	99.94	14	96.52	11
9	A2	99.82	1	100	1	95.99	14
10	A5	99.98	7	100	1	96.73	8
11	A3	99.91	6	99.99	8	96.1	13
12	A7	99.97	7	100	1	96.44	12
13	A14	99.97	13	100	1	99.22	2
14	A15	99.95	14	100	1	99.15	5
15	A13	99.97	15	99.96	13	99.18	4

80

81 Table 10 shows the rate of acceptable scenarios for alternatives in ETA, which can be  
 82 compared with the reliability-based ranking of alternatives. As shown in the table, higher rate of  
 83 acceptable scenarios cannot necessarily lead to better rank based on reliability. For example, the  
 84 effluent quality for 87.5% of total scenarios in alternative A6 is acceptable (i.e. within the  
 85 allowable limits) but reliability-based rank of this alternative is fifth. This can be linked to the  
 86 failure probability of acceptable scenarios, which is lower in alternatives with higher reliability-  
 87 based ranks.

88



89

**Table 10 Rate of acceptable scenarios of alternatives in ETA**

Rank based on reliability	Alternative No	Number of acceptable scenarios	Total number of scenarios	% success
1	A12	10	32	31.25
2	A11	11	32	34.38
3	A10	10	32	31.25
4	A1	18	32	43.75
5	A6	14	16	87.50
6	A9	10	16	37.50
7	A4	20	32	37.50
8	A8	10	16	37.50
9	A2	10	16	37.50
10	A5	10	16	37.50
11	A3	20	32	37.50
12	A7	5	16	31.25
13	A14	12	16	25.00
14	A15	12	16	25.00
15	A13	14	16	12.50

90

91 Fig. 11 also shows the percentage of unacceptable scenarios with respect to each water quality  
 92 parameters of effluent. As shown in the figure, violation of TDS limit is the major reason for  
 93 unacceptance of scenarios in most of alternatives except the last three alternatives (A13-A15) in  
 94 which COD limit is the major reason for unaccepting scenarios. Therefore, TDS removal  
 95 efficiency can be considered as a key factor when designing a new ATU system which can  
 96 effectively have impact on achieving a larger rate of acceptable scenarios and hence reliability of  
 97 the system.

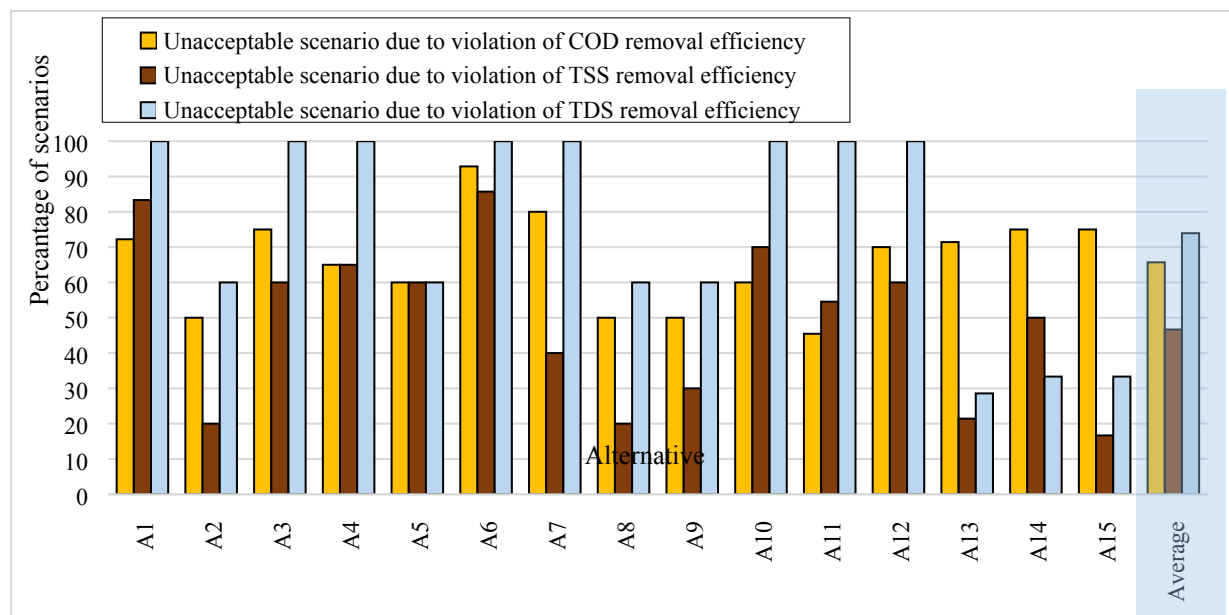

Fig. 11 Percentage of unacceptable scenarios with respect to water quality parameters of effluent

## 5 Conclusions

This paper presented a new methodological framework to investigate the potential of combined fuzzy FTA and ETA for reliability assessment and prioritisation of hybrid system alternatives in advanced treatment units of industrial wastewater. The methodology was specifically demonstrated on a real case study in a developing countries with poor data and experience available for these hybrid systems. The framework employed a combined analysis of event tree and fuzzy fault tree to identify failure probability of advanced treatment processes in series. More specifically, FTA was structured as a fault tree representing main causes of ATU failure in three levels of top, intermediate and base events. Failure probability of base events were obtained by using fuzzy logic and linguistic terms of a number of experts' judgements expressing the main causes of ATU failures in the case study. Then, ETA was used to calculate a reliability of each hybrid system alternative. This was achieved through a statistical analysis for success scenarios (i.e. concentration of pollutants in effluent of the hybrid system falls within standard limits) of failure events (i.e. once one or more ATUs fails in the hybrid system). The feasible alternatives of hybrid ATU systems were finally ranked based on the calculated reliability. Based on the results obtained in the case study, the following conclusions are drawn:

- 117       • The suggested methodology and framework provided a standard platform for failure  
118 assessment of both individual ATUs and hybrid ATU systems where historic data  
119 collection and experience for such treatment systems is a major obstacle. This is  
120 particularly important for new developments of industrial wastewater treatment with  
121 no or little previous experience of these systems and minimises the failure risk of capital  
122 investment.
- 123       • This framework is a useful tool for failure risk assessment and prioritisation of various  
124 combinations of ATUs and selecting the best combination of advanced treatment units  
125 with highest reliability.
- 126       • The failure probability of each ATU is individually determined based on fuzzy FTA  
127 based on the linguistic judgements of a number of experts on the main causes of ATU  
128 failure. The failure probabilities of individual ATUs is then used by ETA to determine  
129 reliability of feasible hybrid system alternatives in the case study analysed here. The  
130 failure probabilities obtained here are valuable data for reliability assessment of any  
131 other potential combination of ATUs at the national scale.
- 132       • The results in the paper show no correlation between the average of success probability  
133 of individual ATUs in a hybrid system and the overall reliability of the system.  
134 Therefore, a higher average removal efficiency for the individual ATUs cannot  
135 necessarily lead to a more reliable hybrid system.
- 136       • In addition to feasible hybrid systems tested/suggested in the case study, the analyses  
137 of failure probability in this study can be used to create some hybrid systems with high  
138 reliability. On the other hand, the feasible hybrid ATU systems with low reliability  
139 evaluated by this methodology can be analysed later on for improvement of main  
140 causes of ATU failure by focusing on the base events with highest failure.

141       The failure probability of individual ATUs in this study were obtained based on the linguistic  
142 judgements of different experts on the failure rate those ATUs. Although the accumulation of  
143 experts' judgements is based on a weighted average with respect to the experience of experts, this  
144 can only be applied to specific manufacturing of the analysed ATUs. If a new manufacturing for a  
145 ATU with different quality and performance is intended to be used in a hybrid system, the

146 judgments of experts used in this study cannot be applied for reliability assessment of the same  
147 hybrid systems. In addition, using the failure probability of ATUs obtained in this study cannot be  
148 directly used for similar systems elsewhere in the world due mainly to different features and  
149 performance of individual ATUs. However, the framework suggested in this paper can be applied  
150 similarly. As the results obtained in this methodology are based on experts' judgments, further  
151 sensitivity analysis needs to be conducted especially on ATUs and their base events with high  
152 failure probability before they can be recommended to decision makers. In addition to the  
153 reliability assessment of hybrid ATU systems, its correlation with other performance indicators  
154 (e.g. overall removal efficiency, cost-effectiveness and etc.) should also be analysed to make a  
155 multi criteria decision based on sustainability.

### 156 **Acknowledgement**

157 Authors would thank to all staff and managers of Iran small industries and industrial parks  
158 organization, Pars Ariyan consulting company, Water and wastewater research consulting  
159 company and Faraz Ab consulting company for their honestly cooperation to complete required  
160 data.

### 161 **References**

- 162 Abdelgawad M., Fayek A.R., 2012. Comprehensive Hybrid Framework for Risk Analysis in the  
163 Construction Industry Using Combined Failure Mode and Effect Analysis, Fault Trees,  
164 Event Trees, and Fuzzy Logic. *Journal of Construction Engineering and Management*  
165 138(5), 642-651.
- 166 Adewumi J.R., Ilemobade A.A., Van Zyl, J.E., 2010. Treated waste water reuse in South Africa:  
167 Overview, potential and challenges. *Resources, Conservation and Recycling* 55(2), 221-231.  
168 <https://doi.org/10.1016/j.resconrec.2010.09.012>
- 169 Ahmadi M., Behzadian K., Ardeshir, A., Zoran K., 2016. Comprehensive Risk Management using  
170 Fuzzy FMEA and MCDA Techniques: A case Study of a Highway Construction Project in  
171 Iran. *Journal of construction engineering and management*,  
172 <http://dx.doi.org/10.3846/13923730.2015.1068847>
- 173 Akhundi A., Nazif S., 2018, "Sustainability assessment of wastewater reuse alternatives using the  
174 evidential reasoning approach", *ournal of Cleaner Production* (2018),  
175 doi:10.1016/j.jclepro.2018.05.220.

- 176 Alderson M.P., dos Santos A.B., Mota Filho C.R., 2015. Reliability analysis of low-cost, full-scale  
177 domestic wastewater treatment plants for reuse in aquaculture and agriculture. *Ecological*  
178 *Engineering* 82, 6–14.
- 179 Ardeshir A., Mohseni N., Behzadian K., Errington M., 2014. Selection of a bridge construction  
180 site using fuzzy Analytical Hierarchy Process in geographic information system. *Arabian*  
181 *Journal for Science and Engineering* 39(6), 4405–4420. [http://dx.doi.org/10.1007/s13369-](http://dx.doi.org/10.1007/s13369-014-1070-2)  
182 [014-1070-2](http://dx.doi.org/10.1007/s13369-014-1070-2).
- 183 Arroyo P. and Molinos-Senante M., 2018. Selecting appropriate wastewater treatment  
184 technologies using a choosing-by-advantages approach. *Science of the Total Environment*  
185 625, 819-827.
- 186 Bourouni K., 2013. Availability assessment of a reverse osmosis plant: Comparison between  
187 Reliability Block Diagram and Fault Tree Analysis Methods. *Desalination* 313(15), 66-76.  
188 <https://doi.org/10.1016/j.desal.2012.11.025>
- 189 Castillo A., Vall P., Garrido-Baserba M., Comas J., Poch M., 2017. Selection of industrial (food,  
190 drink and milk sector) wastewater treatment technologies: A multi-criteria assessment.  
191 *Journal of Cleaner Production* 143, 180-190. <https://doi.org/10.1016/j.jclepro.2016.12.132>
- 192 Chong M.N., Sharma A.K., Burn S., Saint C.P., 2012. Feasibility study on the application of  
193 advanced oxidation technologies for decentralised wastewater treatment. *Journal of Cleaner*  
194 *Production* 35, 230-238. <https://doi.org/10.1016/j.jclepro.2012.06.003>
- 195 Di Iaconi C., Del Moro G., Bertanza G., Canato M., Laera G., Heimersson S., Svanström M.  
196 2017. Upgrading small wastewater treatment plants with the sequencing batch biofilter  
197 granular reactor technology: Techno-economic and environmental assessment. *Journal of*  
198 *Cleaner Production* 148, 606-615.
- 199 Gouri R.L. and Srinivas V.V., 2015. Reliability Assessment of a Storm Water Drain Network.  
200 *Aquatic Procedia* 4, 772 – 779. doi: 10.1016/j.aqpro.2015.02.160
- 201 Gupta R., Baby A., Arya P.V., Ormsbee L., 2014. Upgrading Reliability of Water Distribution  
202 Networks Recognizing Valve Locations. *Procedia Engineering* 89, 370 – 377. doi:  
203 [10.1016/j.proeng.2014.11.201](https://doi.org/10.1016/j.proeng.2014.11.201)
- 204 Harris J.P., 1985. The application of reliability and availability analysis techniques in the waste  
205 water treatment industry. *Reliability Engineering* 10(4), 193-217.

- 206 ISIPO (Iran small industries and industrial parks organization). 2016. Series of tender documents  
207 for advanced treatment units' design for Iran's industrial parks within 2008-2012– in  
208 Persian.
- 209 Józwiakowski K., Bugajski P., Mucha Z., Wójcik W., Jucherski A., Nastawny M., Siwiec T.,  
210 Mazur A., Obroślak R., Gajewska M., 2017. Reliability and efficiency of pollution removal  
211 during long-term operation of a one-stage constructed wetland system with horizontal flow.  
212 Separation and Purification Technology, doi:  
213 <http://dx.doi.org/10.1016/j.seppur.2017.06.043>
- 214 Józwiakowski K., Bugajski P., Kurek K., De Carvalho M.F.N., Almeida M.A.A., Siwiec T.,  
215 Borowski G.I., Czekala W., Dach J., Gajewska M., 2018. The efficiency and technological  
216 reliability of biogenic compounds removal during long-term operation of a one-stage  
217 subsurface horizontal flow constructed wetland. Separation and Purification Technology  
218 202, 216-226.
- 219 Kalbar P.P., Karmakar S., Asolekar S.R., 2013. The influence of expert opinions on the selection  
220 of wastewater treatment alternatives: A group decision-making approach. Environmental  
221 Management 128(15), 844-851. <https://doi.org/10.1016/j.jenvman.2013.06.034>.
- 222 Karimi A.R., Mehrdadi N., Hashemian S.J., Nabi Bidhendi G.R., Tavakkoli Moghaddam R., 2011.  
223 Selection of wastewater treatment process based on the analytical hierarchy process and  
224 fuzzy analytical hierarchy process methods. International journal of environmental science  
225 and technology 8 (2), 267-280.
- 226 Mahjouri M., Ishak M.B., Torabian A., Abd Manaf L., Halimoon N., Ghoddsi J. 2017. Optimal  
227 selection of Iron and Steel wastewater treatment technology using integrated multi-criteria  
228 decision making techniques and fuzzy logic. Process Safety and Environment Protection,  
229 <http://dx.doi.org/10.1016/j.psep.2017.01.016>.
- 230 Metcalf & Eddy. 2003. Wastewater Engineering: Treatment, and Reuse. 4th Ed. Metcalf & Eddy,  
231 Inc., New York, USA.
- 232 Molinos-Senante M., Gómez T., Garrido-Baserba M., Caballero R., Sala-Garrido R., 2014  
233 .Assessing the sustainability of small wastewater treatment systems: A composite indicator  
234 approach. Science of the Total Environment 497–498, 607–617.

- 235 Mya Tun C., Groth A.M. 2011. Sustainable integrated membrane contactor process for water  
236 reclamation, sodium sulfate salt and energy recovery from industrial effluent. *Desalination*  
237 283,187-192. <https://doi.org/10.1016/j.desal.2011.03.054>
- 238 Nývlt O., Prívvara S., Ferkl L., 2011. Probabilistic risk assessment of highway tunnels. *Tunnelling*  
239 and *Underground Space Technology*, 26(1): 71-82.  
240 <http://dx.doi.org/10.1016/j.tust.2010.06.010>
- 241 Oliveira S.C., Sperling M.V., 2008. Reliability analysis of wastewater treatment plants. *Water*  
242 *Research* 42(4-5), 1182-1194.
- 243 Piadeh F., Alavi Moghaddam M.R., Mardan S., 2014. Present situation of wastewater treatment in  
244 the Iranian industrial estates: Recycle and reuse as a solution for achieving goals of eco-  
245 industrial parks. *Resources, Conservation and Recycling* 92, 172-178.  
246 <http://dx.doi.org/10.1016/j.resconrec.2014.06.004>.
- 247 Piadeh F., Alavi Moghaddam M.R., Mardan S., 2018. Assessment of sustainability of a hybrid of  
248 advanced treatment technologies for recycling industrial wastewater in developing countries:  
249 Case study of Iranian industrial parks. *Journal of Cleaner Production* 170, 1136-1150.  
250 <https://doi.org/10.1016/j.jclepro.2017.09.174>.
- 251 Purba J.H., 2014. A fuzzy-based reliability approach to evaluate basic events of fault tree analysis  
252 for nuclear power plant probabilistic safety assessment. *Annals of Nuclear Energy* , 70, 21-  
253 29.
- 254 Rajakarunakaran S., Kumar A.M., Prabhu V.A., 2015. Applications of fuzzy faulty tree analysis  
255 and expert elicitation for evaluation of risks in LPG refueling station. *Journal of Loss*  
256 *Prevention in the Process Industries* 33, 109-123. DOI10.1016/j.jlp.2014.11.016
- 257 Silva C., Quadros S., Ramalho P., Rosa M.J., 2014. A tool for a comprehensive assessment of  
258 treated wastewater quality. *Journal of Environmental Management*, 146: 400-406.  
259 <https://doi.org/10.1016/j.jenvman.2014.03.028>
- 260 Üstün G.E., Solmaz S.K.A., Çiner F., Başkaya H.S. 2011. Tertiary treatment of a secondary  
261 effluent by the coupling of coagulation-flocculation-disinfection for irrigation reuse.  
262 *Desalination* 277 (1-3), 207-212. <http://dx.doi.org/10.1016/j.desal.2011.04.032>.  
263 <https://doi.org/10.1016/j.desal.2011.04.032>
- 264 Wojciechowsk E., Gajewsk M., Ostojski A., 2016. Reliability of nitrogen removal processes in  
265 multistage treatment wetlands receiving high-strength wastewater. *Ecological Engineering*

- 266 Yuhuaa D., Dataob Y., 2005, Estimation of failure probability of oil and gas transmission pipelines  
267 by fuzzy fault tree analysis. *Journal of Loss Prevention in the Process Industries* 18(2), 83-  
268 88. <https://doi.org/10.1016/j.jlp.2004.12.003>
- 269 Zhang K., Achari G., Sadiq R., Langford C.H., Dore M.H.I., 2012. An integrated performance  
270 assessment framework for water treatment plants. *Water Research* 46(6), 1673–1683.  
271 <https://doi.org/10.1016/j.watres.2011.12.006>
- 272 Zhu R., Yang C., Zhou M., Wang J., 2015. Industrial park wastewater deeply treated and reused  
273 by a novel electrochemical oxidation reactor. *Chemical Engineering Journal* 260, 427-433.  
274 <https://doi.org/10.1016/j.watres.2011.12.006>
- 275 Zio, E., 2007. *An introduction to the basics of reliability and risk analysis*, 1st Ed., World Scientific  
276 Publishing Co. Pte. Ltd, London, UK. <https://doi.org/10.1016/j.cej.2014.09.029>
- 277



278 **Appendix A:**279 **Table A.1 Estimation of removal efficiency in advanced treatment units of industrial wastewater treatment in**  
280 **the literatures**

Advanced treatment unit	Removal efficiency of pollutants	Reference
RO	98.18 TDS	Nandy <i>et al.</i> 2007
UF	83.33% COD / 2% TDS	Nandy <i>et al.</i> 2007
C&F	95% COD / 85% TSS	Amuda and Amoo 2007
MBR	95.52% COD / 99% TSS	Tam <i>et al.</i> 2007
MF	95.42% COD / 99% TSS / 93.63% TDS	Tam <i>et al.</i> 2007
RO	88.57% COD / 87.54% TDS	Tam <i>et al.</i> 2007
Per.	26.75% COD / 96% TSS / 1.6% TDS	Solmaz <i>et al.</i> 2007
C&F	83% TSS / 17% TDS	Üstünn <i>et al.</i> 2007
IE	51.76% COD / 99% TSS / 98.68% TDS	Üstünn <i>et al.</i> 2007
RO	95% COD	Vourch <i>et al.</i> 2008
C&F	91% COD / 99.4% TSS	Ahmad <i>et al.</i> 2012
UF	95% COD	Zirehpour <i>et al.</i> 2008
DAF	77% COD / 74% TSS	De Nardi <i>et al.</i> 2008
DAF	72% COD / 92% TSS	Al-Mutairi <i>et al.</i> 2008
MBR	93.74% COD	Hoinkis and Panten 2008
O <sub>3</sub>	71% COD	Germirli Babuna <i>et al.</i> 2009
O <sub>3</sub>	70% COD	Preethi <i>et al.</i> 2009
MBR	95.2% COD / 99.8% TSS	Takht Ravanchi <i>et al.</i> 2009
SF	79% COD / 90% TSS	Achak 2009
DAF	80.3% COD / 75.5% TSS	De Sena <i>et al.</i> 2009
AC	76.74% COD / 97.59% TSS	Ciabattia <i>et al.</i> 2009
RO	98% COD	Madaeni and Eslamifard 2010
O <sub>3</sub>	55% COD	Tehrani-Bagha <i>et al.</i> 2010
C&F	72.5% COD	Aber <i>et al.</i> 2010
MBR	91.97% COD / 99.47% TSS / 18.3% TDS	Brannock <i>et al.</i> 2010
DAF	77.5% COD / 88.7% TSS	El-Gohary <i>et al.</i> 2010
Per.	76.7% COD / 93.6% TSS	El-Gohary <i>et al.</i> 2010
RO	93.6% COD / 97.5% TSS / 95.1% TDS	Huang <i>et al.</i> 2011
UF	66.9% COD / 95.8 TSS / 1.8% TDS	Huang <i>et al.</i> 2011

Advanced treatment unit	Removal efficiency of pollutants	Reference
C&F	75% COD / 98% TSS / 17% TDS	Ayoub <i>et al.</i> 2011
MF	86.67% TSS	Ordóñez <i>et al.</i> 2011
C&F	60% COD / 94% TSS	Ayeche 2012
MBR	99.9% COD	López-Fernández <i>et al.</i> 2012
RO	93.3% COD	Kurt <i>et al.</i> 2012
MBR	96.19% COD / 97.84% TSS	Malamis <i>et al.</i> 2012
RO	80.95% COD / 96.85% TDS	Chowdhury <i>et al.</i> 2013
O <sub>3</sub>	89% COD / 18% TDS	Ferella <i>et al.</i> 2013
SF	94% COD / 31% TDS	Ferella <i>et al.</i> 2013
MBR	87.7% COD	Chung and Kim 2013
MBR	96.98% COD	Lei <i>et al.</i> 2010
MBBR	96.98% MBBR	Lei <i>et al.</i> 2010
MBR	97.9% COD	Andrade <i>et al.</i> 2014
UF	22% COD / 89.97% COD	Petricin <i>et al.</i> 2015
RO	99.99% COD / 99.97% TSS	Petricin <i>et al.</i> 2015
MBR	55.65% COD / 8.17% TDS	Yao <i>et al.</i> 2016

#### 281 **Related References for Table A1:**

- 282 Aber, S., Salari, D., Parsa, M.R., 2010. Employing the Taguchi method to obtain the optimum  
283 conditions of coagulation–flocculation process in tannery wastewater treatment. *Chemical*  
284 *Engineering* 162(1), 127-134.
- 285 Achak, M., Mandi, L., Ouazzani, N., 2009. Removal of organic pollutants and nutrients from olive  
286 mill wastewater by a sand filter. *Environmental Management* 90 (8), 2771-2779.
- 287 Ahmad, A.L., Wong, S.S., Teng, T.T., Zuhairi, A., 2008. Improvement of alum and PACl  
288 coagulation by polyacrylamides (PAMs) for the treatment of pulp and paper mill wastewater.  
289 *Chemical Engineering* 137(3), 510-517.
- 290 Al-Mutairi, N.Z., Al-Sharifi, F.A., Al-Shammari, S.B., 2008. Evaluation study of a slaughterhouse  
291 wastewater treatment plant including contact-assisted activated sludge and DAF.  
292 *Desalination* 225 (1-3), 167-175.
- 293 Amuda, O.S., Amoo, I.A., 2007. Coagulation/flocculation process and sludge conditioning in  
294 beverage industrial wastewater treatment. *Journal of Hazardous Materials* 141(3), 778-783.

- 295 Andrade, L.H., Mendes, F.D.S., Espindola, J.C., Amaral, M.C.S., 2014. Nanofiltration as tertiary  
296 treatment for the reuse of dairy wastewater treated by membrane bioreactor. *Separation and*  
297 *Purification Technology* 126, 21-29.
- 298 Ayeche, R., 2012. Treatment by coagulation-flocculation of dairy wastewater with the residual  
299 lime of National Algerian Industrial Gases Company (NIGC-Annaba). *Energy Procedia* 18,  
300 147-156.
- 301 Ayoub, G.M., Hamzeh, A., Semerjian, L., 2011. Post treatment of tannery wastewater using  
302 lime/bittern coagulation and activated carbon adsorption. *Desalination* 273 (2-3), 359-365
- 303 Brannock, M., Leslie, G., Wang, Y., Buethorn S., 2010. Optimising mixing and nutrient removal  
304 in membrane bioreactors CFD modelling and experimental validation. *Desalination* 250 (2),  
305 815-818
- 306 Chowdhury, M., Mostafa, M.G., Biswas, T. K., Saha, A. K., 2013. Treatment of leather industrial  
307 effluents by filtration and coagulation processes. *Water Resources and Industry* 3, 11-22.
- 308 Chung, J., Kim, J., 2013. Wastewater treatment using membrane bioreactor and reverse osmosis  
309 process. *Desalination and Water Treatment* 51 (25-27), 5298-5306.
- 310 Ciabattia, I., Cesaro, F., Faralli, L., Fatarella, E., Tognotti, F., 2009. Demonstration of a treatment  
311 system for purification and reuse of laundry wastewater. *Desalination* 245(1-3), 451-459.
- 312 De Nardi, I.R., Fuzi, T.P., Del Nery V., 2008. Performance evaluation and operating strategies of  
313 dissolved-air flotation system treating poultry slaughterhouse wastewater. *Resources,*  
314 *Conservation and Recycling* 52 (3), 533-544.
- 315 De Sena, R.F., Tambosi, J.L., Genena, A.K., Moreira, R.F.P.M., Schröder, H.F., José H.J., 2009.  
316 Treatment of meat industry wastewater using dissolved air flotation and advanced oxidation  
317 processes monitored by GC-MS and LC-MS. *Chemical Engineering* 152 (1), 151-157.
- 318 El-Gohary, F., Tawfik, A., Mahmoud, U., 2010. Comparative study between chemical  
319 coagulation/precipitation (C/P) versus coagulation/dissolved air flotation (C/DAF) for pre-  
320 treatment of personal care products (PCPs) wastewater. *Desalination* 252 (1-3), 106-112
- 321 Ferella, F., De Michelis, I., Zerbini, C., Vegliò, F., 2013. Advanced treatment of industrial  
322 wastewater by membrane filtration and ozonization. *Desalination* 313, 1-11.
- 323 Germirli Babuna, F., Camur, S., Arslan Alaton, I., Okay, O., Iskender, G., 2009. The application  
324 of ozonation for the detoxification and biodegradability improvement of a textile auxiliary:  
325 Naphtalene sulphonic acid. *Desalination* 249(2), 682-686.

- 326 Hoinkis, J., Panten, V., 2008. Wastewater recycling in laundries—From pilot to large-scale plant.  
327 *Chemical Engineering and Processing: Process Intensification* 47(7), 1159-1164.
- 328 Huang, C.J., Yang, B.M., Chen, K.S., Chang, C.C., Kao, C.M., 2011. Application of membrane  
329 technology on semiconductor wastewater reclamation: A pilot-scale study. *Desalination* 278  
330 (1-3), 203-210
- 331 Hwang, Y., Maeng, M., Dockko, S., 2015. Development of a hybrid system for advanced  
332 wastewater treatment using high-rate settling and a flotation system with ballasted media.  
333 *International Biodeterioration & Biodegradation* 113, 256–261.
- 334 Kurt, E., Koseoglu-Imer, D.Y., Dizge, N., Chellam, S., Koyuncu, I., 2012. Pilot-scale evaluation  
335 of nanofiltration and reverse osmosis for process reuse of segregated textile dyewash  
336 wastewater. *Desalination*. 302, 24-32.
- 337 Lei, G., Ren, H., Ding, L., Wang, F., Zhang, X., 2010. A full-scale biological treatment system  
338 application in the treated wastewater of pharmaceutical industrial park. *Bioresource*  
339 *Technology* 101, 5852–5861.
- 340 López-Fernández, R., Martínez, L., Villaverde, S., 2012. Membrane bioreactor for the treatment  
341 of pharmaceutical wastewater containing corticosteroids. *Desalination* 300, 19-23.
- 342 Madaeni, S.S., Eslamifard, M.R., 2010. Recycle unit wastewater treatment in petrochemical  
343 complex using reverse osmosis process. *Journal of Hazardous Materials* 174(1-3), 404-409.
- 344 Malamis, S., Katsou, E., Takopoulos, K., Demetriou, P., Loizidou, M., 2012. Assessment of metal  
345 removal, biomass activity and RO concentrate treatment in an MBR–RO system. *Hazardous*  
346 *Materials* 209–210, 1-8.
- 347 Nandy, T., Manekar, P., Dhodapkar, R., Pophali, G., Devotta, S., 2007. Water conservation  
348 through implementation of ultrafiltration and reverse osmosis system with recourse to  
349 recycling of effluent in textile industry—A case study. *Resources, Conservation and*  
350 *Recycling* 51(1), 64-77.
- 351 Ordóñez, R., Hermosilla, D., San Pío, I., Blanco, Á., 2011. Evaluation of MF and UF as  
352 pretreatments prior to RO applied to reclaim municipal wastewater for freshwater  
353 substitution in a paper mill: A practical experience. *Chemical Engineering Journal* 166 (1),  
354 88-98.

- 355 Petrinic, I., Korenak, J., Povodnik, D., Hélix-Nielsen, C., 2015. A feasibility study of  
356 ultrafiltration/reverse osmosis (UF/RO)-based wastewater treatment and reuse in the metal  
357 finishing industry. *Journal of Cleaner Production* 101, 292-300.
- 358 Preethi, V., Kalyani, K.S.P., Iyappan, K., Srinivasakannan, C., Balasubramaniam, N., Vedaraman,  
359 N., 2009. Ozonation of tannery effluent for removal of cod and color. *Journal of Hazardous*  
360 *Materials* 166(1): 150-154.
- 361 Solmaz, S.K.A., Ekrem Üstün, G., Birgül, A., Taşdemir, Y., 2007. Treatability studies with  
362 chemical precipitation and ion exchange for an organized industrial district (OID) effluent  
363 in Bursa, Turkey. *Desalination* 217 (1-3), 301-312.
- 364 Takht Ravanchi, M., Kaghazchi T., Kargari, A., 2009. Application of membrane separation  
365 processes in petrochemical industry: a review. *Desalination* 235 (1-3), 199-224.
- 366 Tehrani-Bagha, A.R., Mahmoodi, N.M., Menger, F.M., 2010. “Degradation of a persistent organic  
367 dye from colored textile wastewater by ozonation. *Desalination* 260(1-3),34-38.
- 368 Tam, L.S., Tang, T.W., Lau, G.N., Sharma, K.R., Chen, G.H. 2007. A pilot study for wastewater  
369 reclamation and reuse with MBR/RO and MF/RO systems. *Desalination* 202 (1-3), 106-113.
- 370 Vourch, M., Balannec, B., Chaufer, B., Dorange, G., 2008. Treatment of dairy industry wastewater  
371 by reverse osmosis for water reuse. *Desalination* 219 (1-3), 190-202.
- 372 Woo, Y.C., Lee, J.J., Shim, W., Shon, H.K., Tijing, L.D., Yao, M., Kim, H., 2016. Effect of  
373 powdered activated carbon on integrated submerged membrane bioreactor–Nano filtration  
374 process for wastewater reclamation. *Bioresource Technology* 210, 18-25.
- 375 Zirehpour, A., Jahanshahi, M., Rahimpour, A., 2012. Unique membrane process integration for  
376 olive oil mill wastewater purification. *Separation and Purification Technology* 96. 124-131.

### Highlights

- Reliability of hybrid advanced treatment unit (ATU) system is evaluated
- Hybrid ATU system is comprised of ATUs of industrial wastewater treatment
- New framework for reliability assessment of hybrid ATU system is proposed
- Reliability assessment is calculated by event tree and fault tree analyses
- 15 hybrid ATU system alternatives is ranked based on Reliability assessment.