

11-1-1990

Simple overdense rf plasma source

R. McWilliams

University of California, Irvine

D. Edrich

University of California, Irvine

R. C. Platt

University of California, Irvine

D. P. Sheehan

University of San Diego, dsheehan@sandiego.edu

Follow this and additional works at: <http://digital.sandiego.edu/phys-faculty>



Part of the [Physics Commons](#)

Digital USD Citation

McWilliams, R.; Edrich, D.; Platt, R. C.; and Sheehan, D. P., "Simple overdense rf plasma source" (1990). *Physics and Biophysics: Faculty Publications*. 19.

<http://digital.sandiego.edu/phys-faculty/19>

This Article is brought to you for free and open access by the Department of Physics and Biophysics at Digital USD. It has been accepted for inclusion in Physics and Biophysics: Faculty Publications by an authorized administrator of Digital USD. For more information, please contact digital@sandiego.edu.

Simple overdense rf plasma source

R. McWilliams, D. Edrich, R. C. Platt,^{a)} and D. P. Sheehan^{b)}
Department of Physics, University of California, Irvine, CA 92717

(Received 21 May 1990; accepted for publication 30 July 1990)

A simple, gas-fed, radio-frequency-driven plasma source is described. By use of lower hybrid waves, noble gas plasmas were produced with electron densities up to 10^{12} cm⁻³ over a range of magnetic fields from 400 G to 1.5 kG and rf frequencies from 2–220 MHz.

I. INTRODUCTION

Radio-frequency driven plasma sources have been used for over 15 years.^{1–3} Generally, these sources couple the rf energy into the plasma formation via specific waves launched into low pressure gases or plasma from a coupler. Many of these sources rely upon wave coupling which require detailed tuning of the source to the desired plasma, such as choosing a source frequency which depends on the background magnetic field. The use of lower hybrid waves provides a radio-frequency plasma source, reasonably decoupled from the magnetic field, generating moderate plasma densities with low temperatures.^{2,3} This article describes a lower hybrid wave plasma source which is simple to construct, and flexible in operation. It is easy to insert and remove from vacuum vessel, provide some desirable boundary conditions for plasma experiments, is relatively decoupled from B field consideration, and can be used with a wide variety of gases.

Previous lower hybrid plasma sources^{2,3} have been successful. The source described here utilizes some of the benefits achieved with these sources while avoiding some of their complexities of design and operation. Earlier lower hybrid sources required substantial matching network electronics and differential vacuum pumping² or were operated in a single-ended “gun” type design.³ Advances in rf amplifiers have obviated some of the matching network requirements. Differential pumping may not be desirable in all cases and the difficulty of doing so may be avoided here. The use of a “gun” type source produces a unidirectional plasma with a metallic boundary condition across the magnetic field at the source. Some experiments benefit from having plasma flow along magnetic field lines without encountering obstacles at the plasma source. A further requirement of source simplicity may demand that a source be removable easily and quickly from the experiment chamber, a characteristic of the source described here.

II. THEORY

The theory of lower hybrid rf plasma sources has been developed previously and compared with experiment.^{2,3} Some essential elements of this theory are repeated here.

Lower hybrid waves (LHW) are free to propagate from the source into the plasma at angles oblique to the plasma confining magnetic field. When a plasma is present

such that the density satisfies $w_{pe} > w$, where w_{pe} and w are the plasma and wave frequencies, respectively, then typically densities of order 10^6 – 10^8 cm⁻³ are required to satisfy this condition for source frequencies in the tens of MHz. The wave and source near fields provide the ionizing electric field for background gas. Thus LHW propagate into the plasma while creating additional plasma, according to the dispersion relation

$$w^2 = w_{LH}^2 (1 + k_{\parallel}^2 m_i / k^2 m_e),$$

where k_{\parallel} is the component of k , the wavenumber, which is parallel to the confining magnetic field. For rf source frequencies below the geometric mean of the ion and electron gyrofrequencies, this process may continue until the plasma density rises sufficiently to make

$$w_{LH} \equiv w_{pi} / (1 + w_{pe}^2 / w_{ce}^2)^{1/2} = w, \quad (1)$$

where w_{pi} is the ion plasma frequency and w_{ce} is the electron gyrofrequency. At a density high enough to satisfy Eq. (1), the rf field is prevented from propagating to higher densities.

Similarly, for waves with w above the mean gyrofrequency, the rf fields will propagate into the plasma until the density rises enough to violate

$$w_{pi}^2 < w^2 \left[\frac{N_{\parallel} w}{\sqrt{w_{ce} w_{ci}}} - \sqrt{1 + N_{\parallel}^2 \left(\frac{w^2}{w_{ce} w_{ci}} - 1 \right)} \right]^2, \quad (2)$$

where $N_{\parallel} = k_{\parallel} c / w$ is the component of the normalized wavenumber parallel to the magnetic field. Hence, there are two possible density limitations and plasma may be created by the rf source until the limit of Eqs. (1) or (2) is encountered. It should be noted that there are relatively few restrictions on the source frequency used. There is also a general trend that higher wave frequencies have higher maximum attainable plasma densities.

Equations (1) and (2) are applied to specific examples in Fig. 1. In Fig. 1(a) a rf source frequency of 10 MHz is applied to argon gas and the resulting maximum density achievable is plotted versus confining magnetic field. For the range of magnetic field examined, only Eq. (2) applies and that prediction is plotted for three different values of N_{\parallel} excited by the rf source. In Fig. 1(b) four different-source wave frequencies are examined, for helium plasmas, all with $N_{\parallel} = 10$ assumed, and in this case both equations

^{a)}Science Applications International Corporation, Albuquerque, NM 87106.

^{b)}Department of Physics, University of San Diego, Alcalá Park, San Diego, CA 92110.

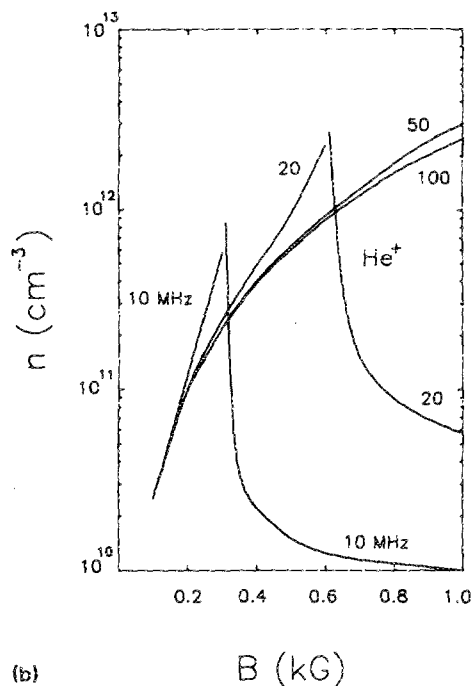
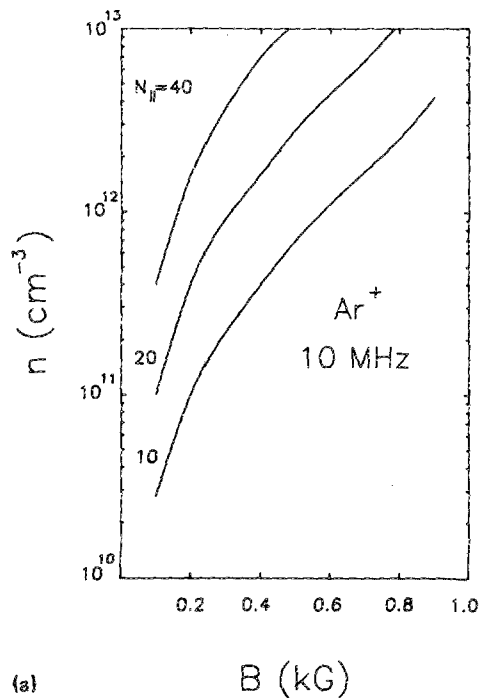

FIG. 1. (a) Theoretical argon plasma density limit vs magnetic field at 10 MHz with $N_{||}$ of 10–40. (b) Theoretical helium plasma density limit vs magnetic field for rf frequencies 10–100 MHz with $N_{||} = 10$.

must be applied to find the maximum achievable densities for the range of magnetic field examined. As an example, at 10 MHz, maximum helium plasma densities in the mid 10^{11} cm^{-3} can be achieved at 300 G, yet the same source could achieve only 10^{10} cm^{-3} at 1 kG. On the other hand, at 50 MHz a density of $3 \times 10^{12} \text{ cm}^{-3}$ could be reached at 1 kG. Graphs similar to Fig. 1 can be generated for other gases from Eqs. (1) and (2).

In order to sustain a plasma, the ion creation rate must overcome ion loss mechanisms. In our experiment, ion dif-

fusion across the confining magnetic field is believed to be the dominant loss mechanism. Earlier work⁴ has established

$$D_{\perp} \approx 4 \frac{cT_e}{eB} \left(\frac{\delta n_i}{n_{i0}} \right)_{\text{rms}}, \quad (3)$$

as the diffusion coefficient due to density fluctuations driven by lower hybrid waves. An upper-limit confinement time τ_p of about 0.4 ms is calculated for cross-field diffusion for this experiment and was found to agree with experiment. The ion creation rate per unit volume is $n_0 n_e (\sigma v)_{iz}$ where n_0 and n_e are the neutral and electron densities and $(\sigma v)_{iz}$ is the ionization rate. The loss and creation rates can be equated when steady state is reached. A significant fraction of free electrons in the oscillating electric field will acquire enough energy to ionize neutrals through collisions. In a singly ionized plasma, a minimum neutral density of

$$n_0 > [\tau_p (\sigma v)_{iz}]^{-1} \quad (4)$$

is necessary for electron collisions with neutrals to sustain the plasma.

There are several avenues for energy loss available to the plasma. The most significant losses are through charge exchange and particle diffusion. The energy loss must be replaced by the rf source in order to maintain the plasma. The rf source must provide a power density

$$P > n_0 n_i (\sigma v)_{cx} \epsilon_{iTH} + (n_e \epsilon_{iTH} + n_e \epsilon_{eTH}) / \tau_p + n_0 n_e (\sigma v)_{iz} \epsilon_{iz}, \quad (5)$$

where ϵ_{iTH} and ϵ_{eTH} are the ion and electron thermal energies, ϵ_{iz} the ionization energy, and $(\sigma v)_{cx}$ the charge exchange rate between ions and neutral atoms.

A balance between the fraction of input power channeled into heating the ions and the power lost through the ions determines the ion temperature, T_i . Calculations based on collisional cross sections from Brown⁵ show charge exchange may be the dominant ion energy loss mechanism and the loss rate increases with increasing T_i . The mechanism for heating the ions is not understood at present. Measurements of T_i were presented in Ref. 2, which speculated that pump-driven low-frequency waves caused the ion heating.

III. APPARATUS

The rf plasma source consists of the rf coupler and the driving circuit. The rf coupler is shown in Fig. 2. It consists of a conducting electrode (such as copper) in the shape of a ring (although the shape need not be so restricted) which is fed by both the gas to be ionized and the rf signal. The ring may be oriented at any angle with respect to the background magnetic field. If the ring is oriented so that the magnetic flux through the ring is maximized, then the plasma formed at radii inside the ring will flow along field lines which do not intersect the rf coupler. Gas is injected into the chamber through a slot in the inside of the ring and, hence, directly into the rf excitation region. This aids in maintaining high neutral gas pressures at the source

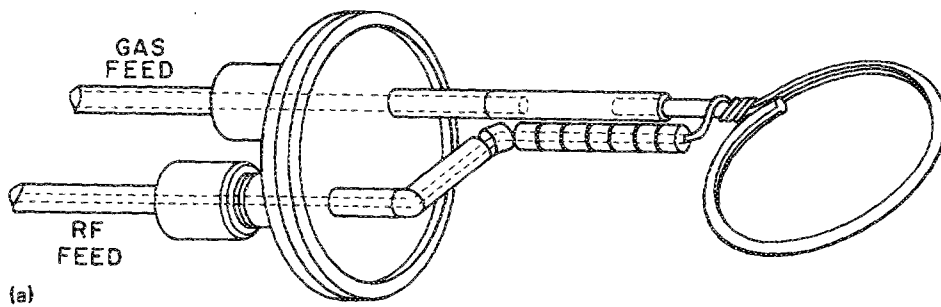

(a)

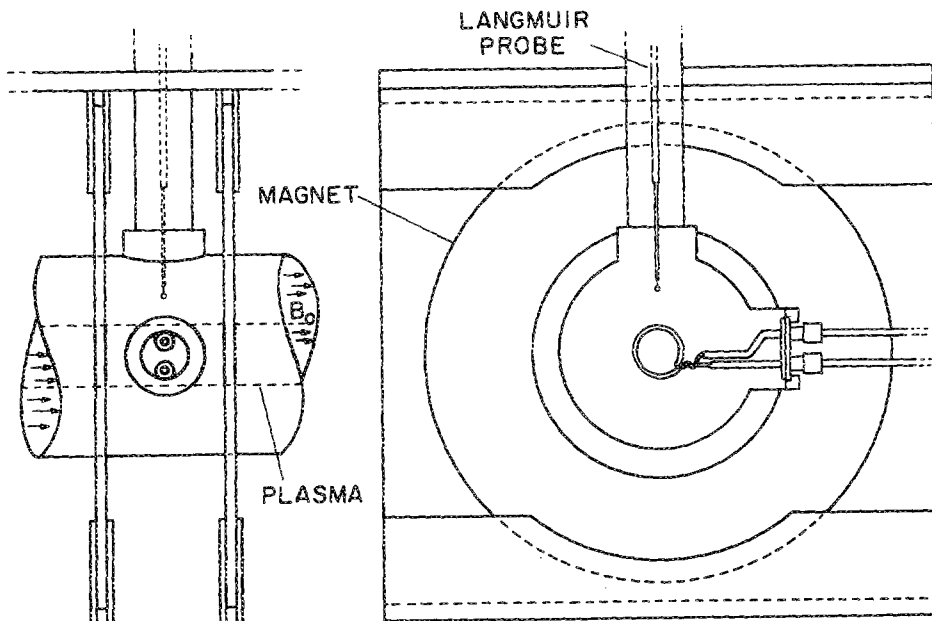

(b)

FIG. 2. (a) Diagram of rf plasma source. (b) Source installed in test bed.

relative to the surrounding vacuum chamber and allows vacuum pumping considerations to be fairly sensitive to design considerations other than those of the rf source.

The input rf signal was fed to the ring through a vacuum-rated coax line which passes into the vacuum and terminated the center conductor on the ring coupler. It was found that solid coax line of length greater than 20 cm could be run directly into the vacuum and still allow base pressures below 1×10^{-6} Torr in the rf source test stand. If the solid coax and gas feed lines were introduced to the vacuum through Wilson seals, then the rf source could be translated without breaking vacuum.

The rf may be fed to the source in either steady-state or pulsed mode of operation. The VSWR of the device depends upon the plasma density and hence varies during operation. The choice of amplifier is important for handling the necessarily variable VSWR. An Amplifier Research Model 1000L, capable of handling any VSWR, provided up to 4 kW pulsed power over 10 kHz–220 MHz for the experiment described here. Directional couplers provided the forward and reflected power data for the rf coupler.

The chamber in which the rf plasma source was tested had an approximately linear magnetic field variable from 0.4–1.5 kG. Base pressure of the chamber was $< 1 \times 10^{-6}$ T before introduction of the neutral gas. Movable Langmuir probes were used to diagnose the plasma.

IV. EXPERIMENTAL RESULTS

Figure 1(b) may be used to determine the magnetic field and source frequency for producing helium plasmas. For example, selecting a magnetic field of 0.5 kG, theoretically the plasma produced cannot exceed $\sim 10^{10} \text{ cm}^{-3}$ for frequencies below 10 MHz. Figure 3 shows the helium plasma density produced by constant forward rf power

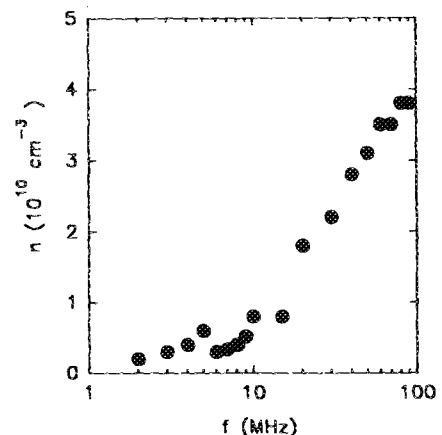

FIG. 3. Plasma density versus rf frequency. Helium neutral pressure = 2.9×10^{-3} Torr, rf power = 400 W, $B = 0.5$ kG.

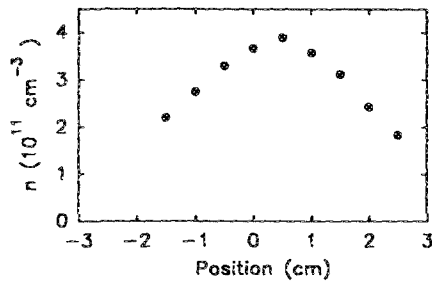

FIG. 4. Plasma density vs radial position. Argon neutral pressure = 2×10^{-4} Torr, rf power = 200 W at 70 MHz, $B = 0.5$ kG.

delivered to the coupler versus rf frequency. For frequencies below 10 MHz, the maximum density achieved was $8 \times 10^9 \text{ cm}^{-3}$. As the wave frequency was raised to 20 MHz, the plasma density rose by more than a factor of 2 and continued to rise as the frequency was increased further. For fixed wave frequency, the density versus magnetic field was examined previously in Ref. 3 and was found to be consistent with the above predictions of Eqs. (1) and (2).

Reference (2) calculates that the electron temperature in such a rf generated plasma will be a function only of the gas pressure and the ratio of T_e/T_i . As shown in Ref. 2, this leads to a strong inverse dependence of electron temperature versus gas pressure and a pressure below which no equilibrium is possible. This threshold pressure drops with increasing gas atomic weight, approximately. From Ref. 2 helium plasma has a calculated threshold pressure of about 3×10^{-4} Torr. With the present rf plasma source it was found that no plasma could be created at pressures below 1.5×10^{-3} Torr, read at a gauge 50 cm from the source.

The plasma density profile across the magnetic field is determined partially by geometry of the rf coupler. With a coupler of circular cross section with inner diameter of approximately 5 cm, the radial density profile was measured and is displayed in Fig. 4. Generally, the density was reasonably flat or peaked near the center. When the gas pressure is raised significantly hollow profiles may be produced.²

Figure 5 shows plasma density versus rf power at fixed pressure and frequency. For the rf coupler described above, 3 kW of power saturates the argon plasma at a density 30% higher than that achieved with helium. Argon densities up to $8 \times 10^{11} \text{ cm}^{-3}$ were achieved at $B = 0.5$ kG, $f = 70$ MHz. These results are consistent with the maxi-

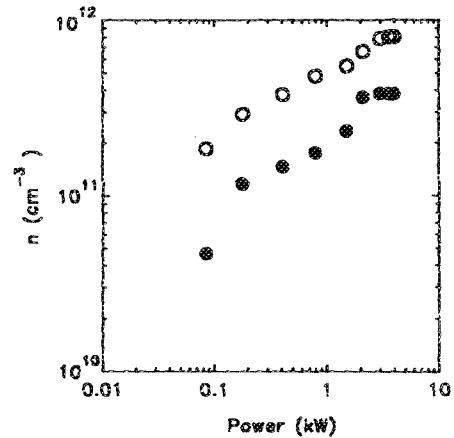

FIG. 5 Maximum attained density as a function of input rf power at 70 MHz. Closed circles represent helium plasma with neutral pressure of 2.9×10^{-3} Torr. Open circles represent argon plasma with neutral pressure of 7×10^{-4} Torr.

mum achievable density predicted in Fig. 1(a) for $N_{||} \approx 10$. The helium plasma density is consistent with the predictions in Fig. 1(b). The rf power provided more than satisfies the power balance of Eq. (5). With a particle loss rate of 0.4 ms and the densities of Fig. 5 a significant fraction of the forward input power must go into reflected power, ion and electron heating, and other waves in the vacuum vessel.

V. DISCUSSION

A simple rf plasma source that utilizes lower hybrid waves has been developed. It does not require differential pumping or a rf matching network. The rf coupler consists of a single conducting loop coaxial with the plasma. It operates over a wide range of frequencies and magnetic fields. Maximum achievable density is consistent with theoretical predictions. Plasma densities up to 10^{12} cm^{-3} have been created with argon and helium.

¹C. Roberson, K.W. Gentle, and P. Nielson, *Phys. Rev. Lett.* **26**, 226 (1971).

²R. W. Motley, S. Bernabei, W. M. Hooke, and D. L. Jassby, *J. Appl. Phys.* **46**, 3286 (1975).

³R. W. Motley, S. Bernabei, and W. M. Hooke, *Rev. Sci. Instrum.* **50**, 1586 (1979).

⁴R. McWilliams, M. Okubo, and N. Wolf, *Phys. Fluids B* **2**, 523 (1990).

⁵S. C. Brown, *Basic Data of Plasma Physics*, 1966, (The MIT Press, Cambridge, MA, 1967).