



**QUEEN'S
UNIVERSITY
BELFAST**

BFRP grid confined clay brick masonry cylinders under axial compression: experimental results

D'Anna, J., Amato, G., Chen, J. F., La Mendola, L., & Minafo', G. (2018). BFRP grid confined clay brick masonry cylinders under axial compression: experimental results. Paper presented at 9th International Conference on Fibre-Reinforced Polymer (FRP) Composites in Civil Engineering, Paris, France.

Document Version:
Peer reviewed version

Queen's University Belfast - Research Portal:
[Link to publication record in Queen's University Belfast Research Portal](#)

Publisher rights
Copyright 2018 The Authors

General rights
Copyright for the publications made accessible via the Queen's University Belfast Research Portal is retained by the author(s) and / or other copyright owners and it is a condition of accessing these publications that users recognise and abide by the legal requirements associated with these rights.

Take down policy
The Research Portal is Queen's institutional repository that provides access to Queen's research output. Every effort has been made to ensure that content in the Research Portal does not infringe any person's rights, or applicable UK laws. If you discover content in the Research Portal that you believe breaches copyright or violates any law, please contact openaccess@qub.ac.uk.



BFRP GRID CONFINED CLAY BRICK MASONRY CYLINDERS UNDER AXIAL COMPRESSION: EXPERIMENTAL RESULTS

Jennifer D'Anna^{1,*}, Giuseppina Amato², Jian-Fei Chen², Lidia La Mendola¹ and Giovanni Minafò¹

¹University of Palermo, Department of Civil, Environmental and Material Engineering (DICAM), Palermo (Italy)

(* corresponding author: jennifer.danna@unipa.it);

²School of Natural and Built Environment, David Keir Building, Queen's University Belfast (UK)

ABSTRACT

The use of composite materials for retrofitting of masonry structures has received great attention during the last two decades. For masonry buildings there are several advantages in using composite materials. Traditional techniques that were largely used and investigated in the past, may be inadequate in seismic areas where the added mass could increase seismic actions. Moreover, for historical and architectural heritage structures, the compatibility, sustainability and reversibility of the intervention is a key factor for the selection of the most appropriate strengthening system. Many investigations have shown that fibre reinforced polymers (FRP) can be effectively used to induce a passive confinement action on masonry columns and improve the axial capacity and ductility of the structural members. This paper presents the results of an experimental study on the compressive behaviour of clay brick masonry cylinders reinforced with basalt fibre reinforced polymer (BFRP) grids. The main aim of this study is to assess the effectiveness of the BFRP wraps on the strength and ductility of masonry columns. Twelve clay brick masonry cylinders, cored from masonry walls and columns, were reinforced using either one or two layers of BFRP grids. Two different arrangements were used for producing the cylinders in order to investigate the effect of vertical joints on the response of masonry cylinders. The basalt grid had a cell size of 6x6 mm. After a preliminary experimental study aimed at characterizing the mechanical properties of bricks, mortar and basalt grid, the cylinders were tested under uniaxial compression loading. The test results showed a strength increase between 30% and 38% for cylinders wrapped with one layer and between 69% and 71% for those wrapped with two layers of BFRP grids.

KEYWORDS

Basalt fibre reinforced polymers; BFRP; Masonry columns; Strengthening and Repair.

INTRODUCTION

Many studies have shown that the use of composite materials can improve the axial capacity and ductility of masonry columns through a confinement action. Although research on this topic is still limited compared to the work carried out for FRP-confined reinforced concrete columns (Campione and Miraglia 2003; Bisby et al. 2011; Ferrotto et al. 2017), the effective contribution of FRP wrap and the evaluation of the ultimate strength of columns have been investigated in several experimental studies. Krevaikas and Triantafillou (2005) investigated the mechanical properties of masonry rectangular columns strengthened with FRP and developed an analytical model in which the hardening factors were calibrated by using experimental results on 42 small-scale specimens. Corradi et al. (2007) carried out compressive tests on FRP confined clay brick columns and proposed a model for calculating the confinement pressure and strength enhancement. Aiello et al. (2007) tested circular masonry columns built with calcareous blocks and reinforced with external FRP wrapping or internal FRP bars. The computation of the ultimate load was conducted using the Italian CNR-DT200 Guidelines (CNR-DT200 2013), an analytical model was used for predicting the expected experimental values.

Alecci et al. (2009) investigated the reliability of available confinement models for small scale masonry cylinders (Richart et al. 1929; Toutanji and Deng (2002); Italian CNR Guidelines) by comparing their predictions with uniaxial and triaxial test results. Di Ludovico et al. (2010) presented the results of an experimental investigation on the compressive behaviour of tuff or clay-brick masonry columns confined with Carbon or Glass FRP and proposed a new model for evaluating the strength enhancement in these members.

More recently, Micelli et al. (2014) studied the mechanical behaviour of circular masonry columns confined with glass and basalt FRP systems. The researchers adopted the model of the Italian CNR Guidelines for predicting the compressive strength of the columns.

This study is part of a larger project which aims at evaluating the confinement provided by both basalt reinforced cementitious mortar composites (BFRCM) and basalt reinforced polymer composites (BFRP) on masonry rectangular columns. As the first step, cylinders were adopted in order to avoid any effects due to corners. Axial compression tests were carried out on twelve small masonry cylinders manufactured using pressed bricks. The cylindrical specimens were cored from preassembled masonry. The effect of the number of vertical joints of the masonry specimens as well as the number of layers of BFRP grid were considered. Only the results from the BFRP grid wrapped cylinders are reported in this paper.

EXPERIMENTAL PROGRAMME

Specimen preparation

Two schemes of brick layup were used for preparing the specimens: wall (Scheme I) and column (Scheme II) (Figure 1). These were assembled using three rows of 50x100x210 mm pressed bricks and 8 mm thick mortar joints. Cylindrical specimens with a diameter of 94 mm and height of about 190 mm were cored from these assemblies using a laboratory-coring machine after curing for 30 days. All specimens had three layers of bricks, but cylinders cored from the masonry walls had only one vertical joint in the middle third while those from the columns had three staggered vertical joints, one at each level.

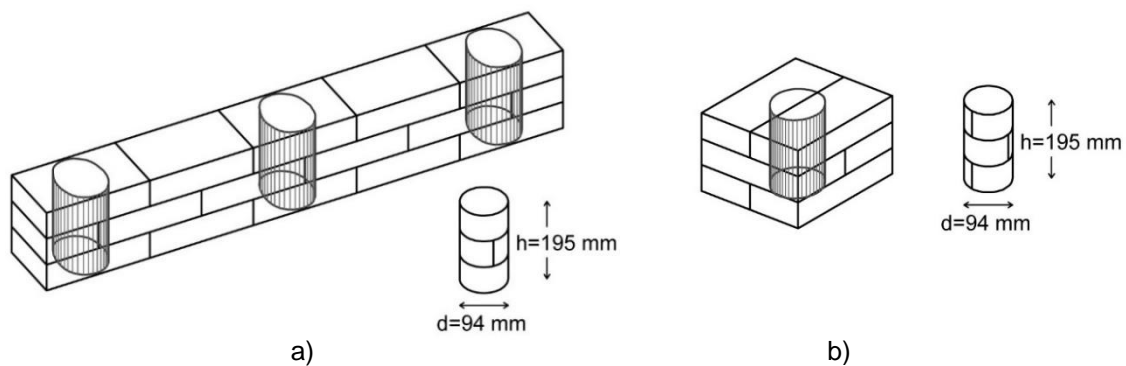

Figure 1: Brick assembly schemes for preparing cylinders: a) Scheme I (wall); b) Scheme II (column).

Twelve clay brick cylinders were tested under axial compressive loading: six cored from Scheme I and six from Scheme II. For each scheme: two specimens were tested with one layer of BFRP grid, two with two layers and two unconfined control specimens, as listed in Table 1.

Table 1: Test specimens

Specimen designation	Number of specimens	Brick layup scheme	Number of vertical joints	Number of BFRP grid layers
WUn	2	Scheme I	1	/
W1L	2	Scheme I	1	1
W2L	2	Scheme I	1	2
CUn	2	Scheme II	3	/
C1L	2	Scheme II	3	1
C2L	2	Scheme II	3	2

FRP grids were installed in the following steps (Figure 2). First a two-component primer was well mixed to obtain a homogeneous fluid resin. An even coat of primer was applied on the clean and dry surface of the masonry specimen with a brush (Figure 2a). A two-component epoxy resin was then mixed and a 2-3mm thick coat was applied with a notched trowel over the still fresh primer (Figure 2b). The epoxy was smoothed using a flat trowel to remove any surface defects. The BFRP grid was then placed over the resin, ensuring there were no creases. A second coat of resin was then applied over the grid so that it was completely covered. A ribbed roller was passed over the epoxy resin to eliminate any air bubbles trapped in the system. The BFRP grid was overlapped by 1/3 of the circumference to ensure that there was sufficient bond (Figure 2c). The specimens were

left to cure for one month. The cylinders were then capped at both ends to ensure levelled top and bottom faces for uniform application of the axial load.

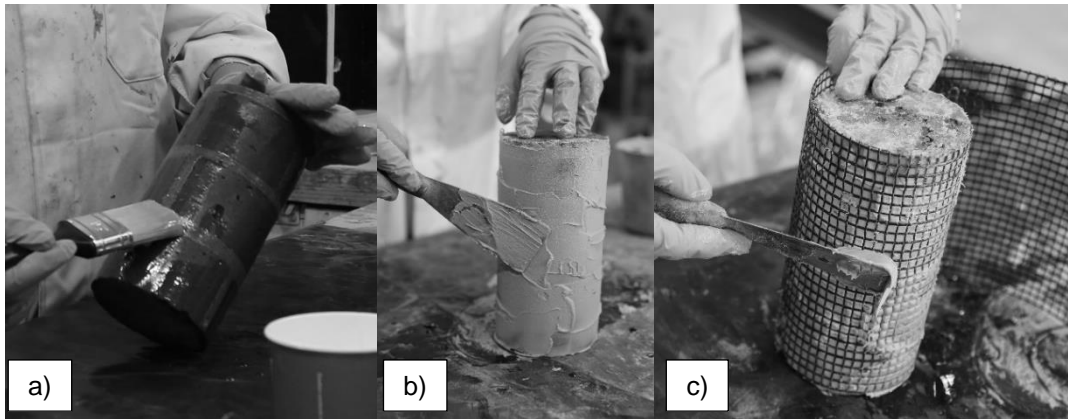

Figure 2: Installation of BFRP grids: a) application of primer; b) application of the first coat of resin; c) installation of basalt grid and second coat of resin.

Material properties

The mechanical properties of the masonry components are shown in Table 2. Six 50mm cubes were cut from bricks and tested under uniaxial compression according to EN 772-1. The average compressive strength was 42.53 MPa.

A cement/sand weight ratio of 1/5 was used for the mortar. Water was added until the minimum workability was achieved. Three-point bending tests were carried out for six standard 40x40x160 mm mortar prisms and uniaxial compressive tests for twelve standard 40 mm cubes according to EN 1015-11. The average tensile and compressive strength are listed in Table 2.

A bidirectional primed alkali-resistant basalt fibre grid with a cell size of 6x6 mm was used. The mechanical properties of the basalt grid and the two parts epoxy resin are reported on Table 3.

Table 2: Mechanical characteristics of bricks and mortar

	Compressive strength [MPa]	Tensile strength [MPa]
Brick	42.53	-
Mortar	20.93	5.33

Table 3: Properties of basalt grid and resin (manufacturer data)

Material	Unit weight	Mesh size	Density	Tensile strength	Elastic modulus	Equivalent thickness	Elongation at failure
BFRP grid	250 g/m ³	6 x 6 mm	2.75 g/cm ³	60 kN/m	89 GPa	0.039 mm	1.8%
Resin				30 MPa	4GPa		

Test Setup

Basalt grid strips

In order to characterize the mechanical behaviour of the BFRP grid, monotonic tensile tests were carried out in accordance with ISO 13934-1. Five 260 mm (length) x 13.5 mm (width) specimens were cut from the BFRP grid and tested using a Zwick universal machine at a loading rate of 1 mm/min. The strips were gripped using

aluminium tabs at the ends. The specimens were lighted up with a retrolight and displacements were recorded using a videoextensometer able to track linear targets attached to the strip over a gauge length of 89 mm.

FRP confined masonry cylinders

The monotonic compressive tests on the cylinders were carried out using a 600 kN Dartec test machine. Three loading/unloading cycles were applied under load control up to 40-50 kN for each specimen, followed by test to failure under displacement control at a loading rate of 0.005 mm/sec.

Four linear voltage differential transducers (LVDTs) were installed to monitor the displacement of the upper loading platen and two were installed on the lower platen (Figure 3). Two extensometers connected to a steel ring were also used to measure the local deformation in the middle half of the specimens. Additionally, the strain field on the surface of the specimens was obtained from digital image correlation (DIC) measurements. Results related to the last two measurement devices are not reported in this paper.



Figure 3: Photo of compressive test setup

TEST RESULTS AND DISCUSSION

Basalt grid strips

Figures 4a and b show the test setup and experimental stress–strain curves for five basalt grid strip specimens. The strips were tested along the warp direction, the circumferential direction when wrapped on the cylinders. As the textile has a discrete distribution of fibre (grid with cell size of 6 mm), the stress value in the graph were obtained considering the width corresponding to the number of yarns in the strip (2 cells and 3 yarns, therefore $d=3 \times 6=18$ mm) and the equivalent fibre thickness (0.039 mm).

The tensile curves exhibited an almost linear elastic brittle behaviour. The average peak stress and strain averaged from five samples were 2240 MPa and 2.7% respectively, both higher than the values provided by the manufacturer. The elastic modulus was 82.8 GPa, slightly lower than the manufacturer value (Table 3).

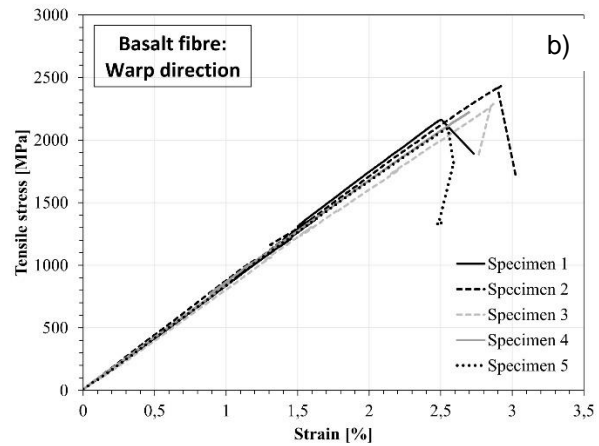
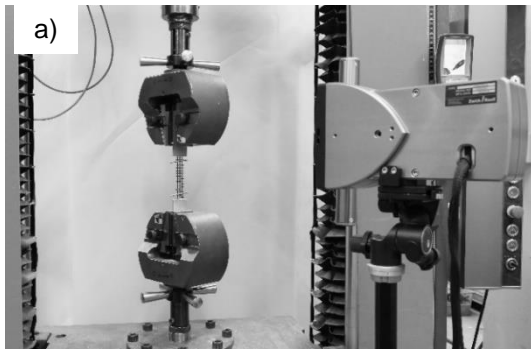

Figure 4: Tensile test of basalt grid: a) test setup; b) stress-strain curves.

Failure modes of masonry cylinder specimens

Figures 5a-d show the failure modes of unwrapped and wrapped cylinders from Schemes I and II. All specimens failed due to the formation of large and almost vertical cracks through at least two thirds of the specimen height. For unconfined specimens (Figures 5a and b), two or more of these cracks turned almost horizontal leading to spalling of bricks. For specimens with BFRP grid warps, their ultimate condition was reached due to the rupture of the basalt texture at the cracks (Figures 5c and d).



Figure 5: Photos of failed cylinders: a) unconfined (Scheme I); b) unconfined (Scheme II); c) Two layer BFRP grid wrapped (Scheme I); d) Two layer BFRP grid wrapped (Scheme II).

FRP confined masonry cylinders

Figures 6a and b show the stress-strain curves for Scheme I and II specimens respectively. The axial stress was calculated by dividing the axial load by the cross sectional area. The axial strain was obtained using the readings from the LVDTs placed at top and bottom platens using a gauge length equal to the cylinder height. Note that the stiffness of the specimens obtained in this way is likely to be significantly lower than the actual stiffness so it may be used as reference only, as it depends significantly on the evenness and parallelity of the top and bottom faces (and platens).

The average peak stress and the corresponding strain are presented in Table 4. The average peak stress for the control specimens was 25.0 MPa and 19.8 MPa respectively for Scheme I and II specimens, showing a significant detrimental effect of the vertical joints. Compared with the unconfined specimens, one layer BFRP grid confinement enhanced the strength by 30% and 38% respectively for Scheme I and II, and two layers by about 70% for both schemes. The enhancement of the strain corresponding to the peak stress is less pronounced: 7% and 10% respectively for Scheme I and II specimens wrapped by one layer of grid, and 19% and 16% for specimens wrapped with two layers.

The confined specimens show a more ductile behaviour as evidenced by a clear softening branch while it is hardly seen for the unconfined reference specimens (Figure 6). Moreover, it can be seen that Scheme II specimens are more ductile with a less steep softening branch than Scheme I specimens.

The stress-strain graphs of Scheme I cylinders show also a certain degree of variability both in relations to strength (specimens confined with two layers), and strain values corresponding to peak load (control specimens and one layer specimens). In particular, as the slope of C1_WUn cylinder is about half of the average of the other specimens, the strain peak value of this cylinder was excluded from the average in Table 4.

The unconfined masonry specimens exhibited, as expected, a brittle behaviour (Figure 6) with near vertical cracks going through the entire height of the specimens, sometimes at the interface between the bricks and mortar in the vertical joints, and crushing of masonry with the spalling of material from the middle to the base of the specimens (Figures 5a and b).

Table 4: Test results of confined and unconfined masonry cylinders

Specimen designation	Brick layup scheme	Average peak stress [MPa]	Average axial strain at peak stress, [%]	Increase of peak stress, [%]	Increase of strain at peak stress, [%]	Ultimate strain, [%]
WUn	I	25.0	0.52*	-	-	-
W1L	I	32.6	0.69	30	7	0.83
W2L	I	42.4	0.76	69	18	0.89
CUn	II	19.8	0.53	-	-	-
C1L	II	27.3	0.58	38	9	0.81
C2L	II	34.0	0.62	71	16	0.98

*C2_WUn specimen only, see Figure 5.

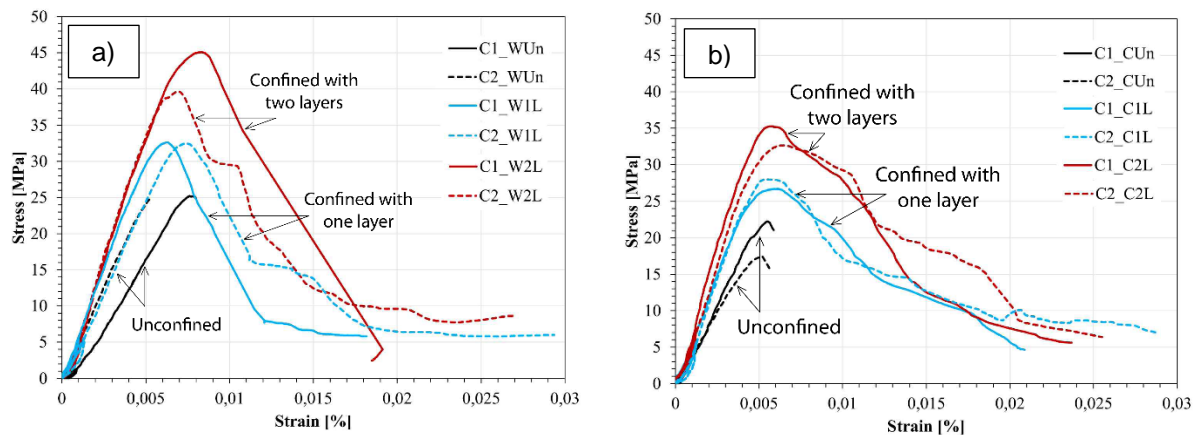

Figure 6: Axial stress-strain curves of unconfined and confined cylinders: a) wall (Scheme I) specimens; b) column (Scheme II) specimens

CONCLUSIONS

This paper has presented the results on an experimental study on the axial compressive behaviour of small masonry cylinders cored from two different brick layup schemes and wrapped with either one or two layers of BFRP grid. The following conclusions can be drawn from the results:

- Unconfined cylinders with three vertical joints (Scheme II) showed an average of 20% strength reduction compared with those with one vertical joint only (Scheme I);
- One layer of FRP grid wrap increased the strength by 30% and 38% respectively for Scheme I and II specimens, and two layers increased the strength by about 70% for both schemes;
- The FRP grid wrap also enhanced the ductility of the specimens showing a softening branch in the stress-strain curve.
- FRP rupture occurred for all FRP confined specimens.

REFERENCES

- M.A. Aiello, F. Micelli, & L. Valente (2007). "Structural upgrading of masonry columns by using composite reinforcements", *Journal of Composites for Construction*, 11(6), 650-658.
- V. Alecci, S. B. Bati, G. Ranocchiali (2009). "Study of Brick Masonry Columns Confined with CFRP", *Composite*, 13(3), 179-187.
- L. A. Bisby, J. F. Chen, S. Q. Li, T. J. Stratford, N. Cuerva, K. Crossling (2011). "Strengthening fire-damaged concrete by confinement with fiber-reinforced polymer wraps", *Engineering Structures*, 33, 3381-3391.
- CNR-DT 200 (R1 2013). Guide for the design and construction of externally bonded FRP systems for strengthening existing structures. Rome: Italian Council of Research (CNR); 1-144.
- G. Campione, N. Miraglia (2003). "Strength and strain capacities of concrete compression members reinforced with FRP", *CemConcr Compos*; 23, 31-41.
- M. Corradi, A. Grazini, A. Borri (2007). "Confinement of brick masonry columns with FRP materials", *Compos Sci Technol*, 67, 1772-83.
- M. Di Ludovico, C. D'Ambra, A. Prota, G. Manfredi (2010). "FRP Confinement of tuff and clay brick columns: experimental study and assessment of analytical models", *J Comp Constr*, 14(5), 583-96.
- EN 1015-11, (1999). "Methods of test for mortar for masonry – Part 11: Determination of flexural and compressive strength of hardened mortar".
- EN 772-1, (2011). "Method of test for masonry units – Part 1: Determination of compressive strength".
- M. Ferrotto, O. Fisher, R. Niedermeier (2017). "Experimental investigation on the compressive behaviour of short-term preloaded carbon fiber reinforced polymer-confined concrete columns", *Structural Concrete*, 1-14. <https://doi.org/10.1002/suco.201700072>.
- ISO 13934-1, (April 2013). "Textiles – Tensile properties of fabrics – Part 1: Determination of maximum force and elongation at maximum force using the strip method". CEN – European Committee for Standardization.
- T. D. Kreaikas, T. C. Triantafillou (2005). "Masonry confinement with fiber-reinforced Polymers", *J Compos Constr*, 9 (2), 128-35.
- F. Micelli, R. Angiuli, P. Corvaglia, M.A. Aiello (2014). "Passive and SMA-activated confinement of circular masonry columns with basalt and glass Fibers composites", *Comp Part B Eng*, 67, 348-62.
- H. Toutanji, Y. Deng. (2002). "Strength and durability performance of concrete axially loaded members confined with AFRP composite sheets", *Composites, Part B*, 33(4), 255-261.
- F. E. Richart, A. Brandtzaeg, R. L. Brown. (1929). "The failure of plain and spirally reinforced concrete in compression", *Bulletin No. 190*, Engineering Experimental Station, Univ. of Illinois, Urbana, Ill., 3-72.