

JOSIP JURAJ STROSSMAYER UNIVERSITY OF OSIJEK
FACULTY OF ELECTRICAL ENGINEERING, COMPUTER SCIENCE AND
INFORMATION TECHNOLOGY OSIJEK

Optimization of the small-scale off- grid PV systems using HOMER

Bachelor thesis

MARIA PIQUER GARCIA

OSIJEK, 2018

SUMMARY

1. INTRODUCTION	3
2. OFF-GRID PHOTOVOLTAIC SYSTEMS	5
2.1. Types of photovoltaic systems.....	5
2.1.1. Off grid-systems	5
2.1.2. On-grid systems	5
2.1.3. Hybrid systems	6
2.2. Configuration of and Off-grid PV system	7
3. ANALYSIS OF CONSUMPTION DATA	9
4. SYSTEM MODELING IN HOMER	12
4.1. Load modeling	12
4.2. PV Modeling.....	14
4.3. Inverter modeling.....	17
4.4. Battery modeling.....	18
5. RESULTS OF THE SIMULATION IN HOMER	20
5.1. Optimal solution for a 0% of capacity shortage	22
5.2. Optimal solution for a 1% of capacity shortage	25
5.3. Optimal solution for a 2% of capacity shortage	29
5.4. Optimal solution for a 3% of capacity shortage	31
5.5. Optimal solution for a 4% of capacity shortage	34
5.6. Optimal solution for a 5% of capacity shortage	37
6. CONCLUSION	40
ABSTRACT	41
REFERENCES	42



1. INTRODUCTION

In the last years the use of photovoltaic systems has grown considerably. According to [1], in 2006 the total global capacity of photovoltaic (PV) systems was about 6 GW and at the end of 2016 it raised to 303 GW, with an increase of 75 GW respect the previous year. These increases are unequal depending of the country. The leaders in additions of capacity during 2016 are in order China, United States, Japan, India and United Kingdom, being together the 85% of the additions. Germany, the Republic of Korea, Australia, the Philippines and Chile follow them. However, in reference to the total power installed China, Japan, Germany, United States, Italy, United Kingdom, India, France, Australia and Spain are in the highest positions [1].

The use of photovoltaic systems is growing due to different factors. In one hand, the electrical necessities of the world are continually increasing. In the other, the governments and the people are more aware of the consequences of the global warming and they are trying to reduce the carbon emissions by using this kind of technologies instead of the fossil fuels. The UE has established some plans for reducing the carbon emissions. Their strategy is to reach some goals for the years 2020 [2], 2030 [3] and 2050 [4] for finally achieving a sustainable development in 2050 in the EU. These plans follow a roadmap for reducing progressively the use of fossil fuels and for increasing the percentage of green energy, storage systems and improving the energy efficiency.

The photovoltaic plants generate electricity directly from the sun radiation. There are three different types of PV systems: the hybrid, the on-grid and the off-grid systems.

The hybrid systems combine the photovoltaic generator with another type of energy source for producing electricity. These hybrid systems can be designed with multiple combinations of different types of energy generators.

The on-grid systems are connected to the power grid. This allows for these systems to feed the grid when they have an excess of production and also to take energy from the grid when they need it.

The other type is the off-grid plants, which are not connected to the grid, but they can have a group of batteries for saving the surpluses of energy and use it when there is no light of the sun or when the necessities of energy are bigger than the production. Off-grid PV systems are mostly used for small scale applications (e.g. For houses, weekend houses, rural areas, etc.) There are many research dealing with off-grid PV systems. This kind of installations is normally used as domestic installations to supply the necessities of a house or a community of people, as is shown in [5]. Also, the research presented in [6] shows the design of an off-grid photovoltaic plant for a typical house in the city of Mashhad in Iran. Off-grid photovoltaic plants are used to give energy to communities without access too. Research presented in [7] describes the development of an off-grid system for a communal rural load in Indonesia. Researches about off grid PV systems applications are also presented in [8], [9], [10], [11], [12] and [13].



FERIT

FAKULTET ELEKTROTEHNIKE, RAČUNARSTVA
I INFORMACIJSKIH TEHNOLOGIJA OSIJEK

This bachelor thesis consists of seven chapters: Introduction, Off-grid photovoltaic systems, Analysis of consumption data, System modeling in HOMER, Results of the simulation in HOMER, Conclusion, Abstract and References.

In this first chapter a short introduction about the situation of the photovoltaic energy is shown. In the second chapter, we explain the different types of PV systems, focusing in off-grid systems, which is the configuration chosen for our installation. In the third chapter, we present and analyze the measured consumption data of the house we have to supply. Then, in the fourth chapter, we explain the steps followed for doing the simulation in HOMER. In the fifth chapter we analyze the results given by the software. In the sixth chapter a conclusion about the obtained results is done. Then we have an abstract that summarize the project. And in the seventh chapter we show the references consulted and used in the development of the project.



2. OFF-GRID PHOTOVOLTAIC SYSTEMS

PV systems generate electrical energy directly from the sun irradiation. We can distinguish three types of PV systems: on-grid, off-grid and hybrid systems, a description of these types of installations is shown in this chapter. As we are designing an off-grid system, we have made a more detailed description of the different parts of this kind of systems.

2.1. Types of photovoltaic systems

In function of the application of the PV installations, there are three basic types of PV systems: the on-grid, the off-grid and the hybrid systems. Below we will explain in detail their characteristics and the differences between them.

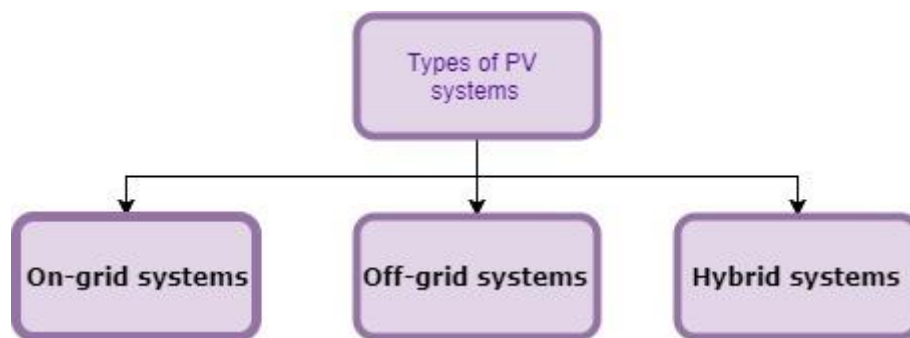

Figure 1: Types of PV systems

2.1.1. Off grid-systems

The off-grid systems produce electricity without having any connection with the electric grid and they are used to supply consumer where they are located. This kind of installation has multiple applications.

We can use it for technological purposes as feeding repeaters of telecommunication installations or telemetry devices. In addition, it lets us to supply systems in the space of the human being, like telecommunications satellites or the International Space Station. Another application is in traffic lights, which have their own solar panel and their battery.

One of the most important applications is to give electricity in rural and isolated areas. Normally they have a storage system with batteries. This can be used for power supply in developing countries or in areas when there is not any electrical commercial grid. Off-grid installations are also used for public lighting in areas when is complicated to bring the conventional electrical grid. Another use of this kind of systems is for pumping stations in places like farms or ranches.

2.1.2. On-grid systems

In on-grid installations, there is not any storage system and they are connected to the electric grid.

The most usual is to use these systems in PV power plants to generate electrical energy that after they deliver it into the grid for supplying the consumers who are connected to it.

In addition, there are domestic power plants connected to the grid, which can be for supply a single house or a group of houses. In these systems when there is a surplus in the production of energy they deliver the excess into the grid. Also, when they are not generating enough energy for the loads they can take energy from the grid. A scheme of an on-grid system is shown in Figure 2.

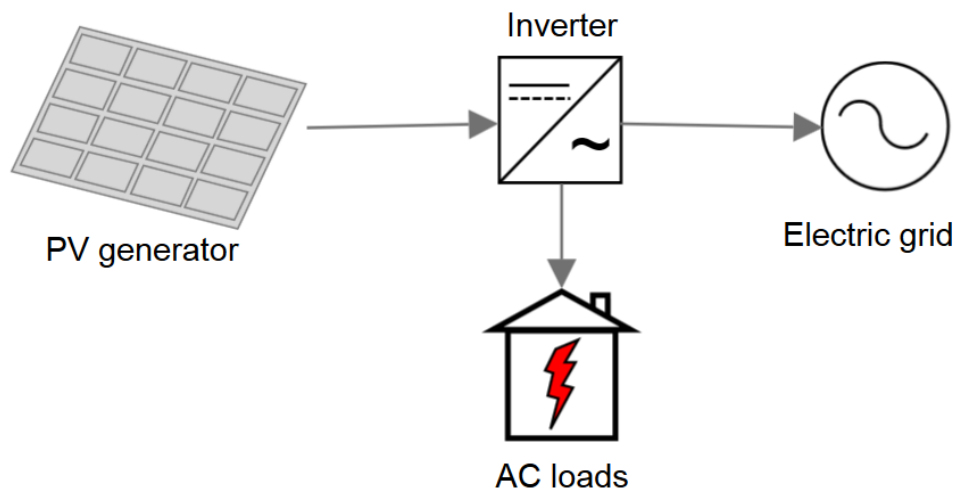

Figure 2: On-grid system scheme

2.1.3. Hybrid systems

The hybrid systems are installations that contain the photovoltaic generator combined with other energy sources for generating electricity. These solutions are designed for situations when the total elimination of fossil fuel generators is not viable.

Hybrid energy systems generate energy through renewable sources, such as sun or wind. With the installation of photovoltaic solar panels and wind turbines a contribution of energy is obtained during the hours of sun or maximum wind. For a continuous operation, these systems have batteries in isolated locations and a back-up diesel generator set for the electricity supply, which turns on in the case of the energy obtained is not enough.

The hybrid energy solutions allow us to minimize the CO₂ emissions. This is because the generating set becomes a source of reinforcement energy, working when necessary instead of doing it 24 hours a day. In this way, the primary energy consumption is reduced since the energy is obtained from renewable and unlimited sources. Being connected to the electricity grid is not essential.

These systems can be applied in different situations, as telecommunications infrastructures, livestock applications with high continuous energy consumption, industrial applications and isolated residential or rural electrification.

In figure 3 a scheme of a kind of hybrid system is presented.

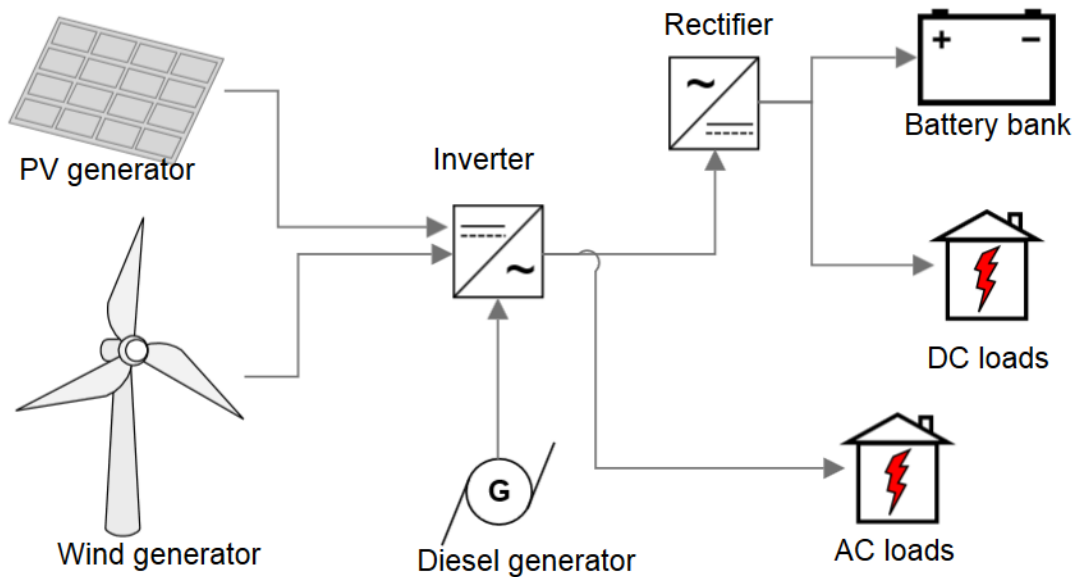

Figure 3: Hybrid system scheme

2.2. Configuration of and Off-grid PV system

The main components of an off-grid domestic system are the photovoltaic array, the batteries, the inverter and/or the charge controller.

The photovoltaic array is the generator and it is the principal part of the installation. It converts the solar energy into electricity. The photovoltaic array is composed of several photovoltaic panels.

The charge regulator is the nexus between the PV panels and the loads. This device protects the batteries of overcharges. In addition, it fixes the nominal working voltage of the installation and gives the DC current of the installation.

The batteries store the energy of the installation and provide it when there is not enough sun. The batteries also give a high snapshot power and fix the working voltage of the installation.

The inverter converts the DC current of the system to AC current, at 220 V of effective value and 50 Hz of frequency, the same as the electrical grid. It also feeds the elements of the installation, which work with DC current.

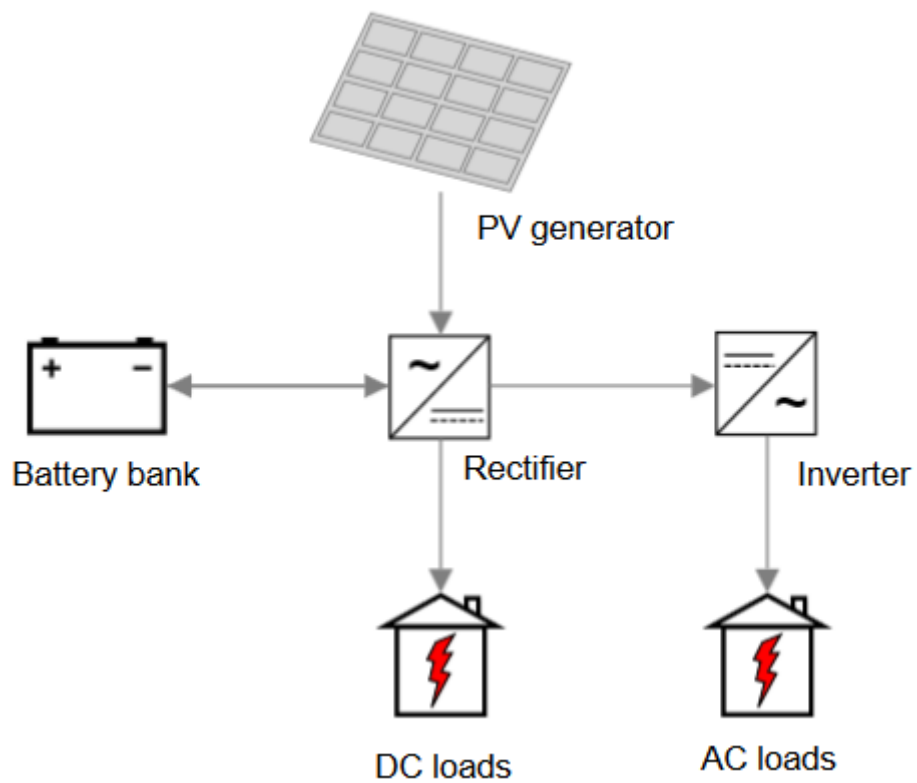

Figure 4: Off-grid system scheme

3. ANALYSIS OF CONSUMPTION DATA

For designing a PV system, first, we have to determinate the energy consumption of the house we are going to supply. Consequently, we have measured the consumed energy during a week by the house. In this chapter, we are going to analyze this data. After, we are going to calculate the average consumption of a typical day in the week and in the weekend. Then, we are going to introduce this data in the software HOMER for modeling our system.

Our measurement starts on Friday 01/09/2017 at 10:10 and finishes on Friday 08/09/2017 at 10:00, which supposes an entire week. We have measured the consumption in intervals of ten minutes. In Figure 5, we can see the measured consumption values (in W) during the week in function of the time.

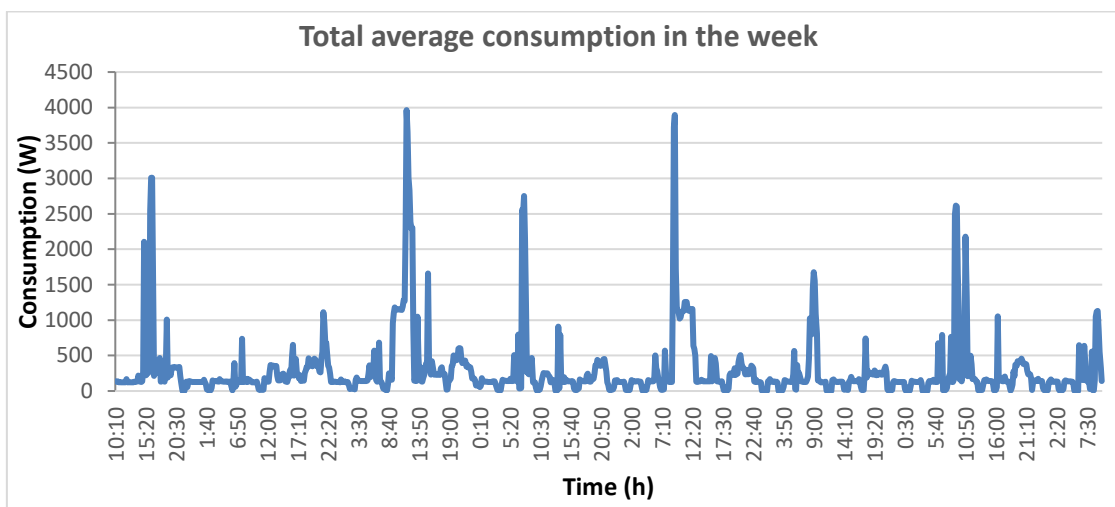

Figure 5: Total average consumption in the week

As we can see, the consumption data are irregular. However, we can appreciate the highest peaks of consumption happen in the mornings when the day begins and all the devices start to work.

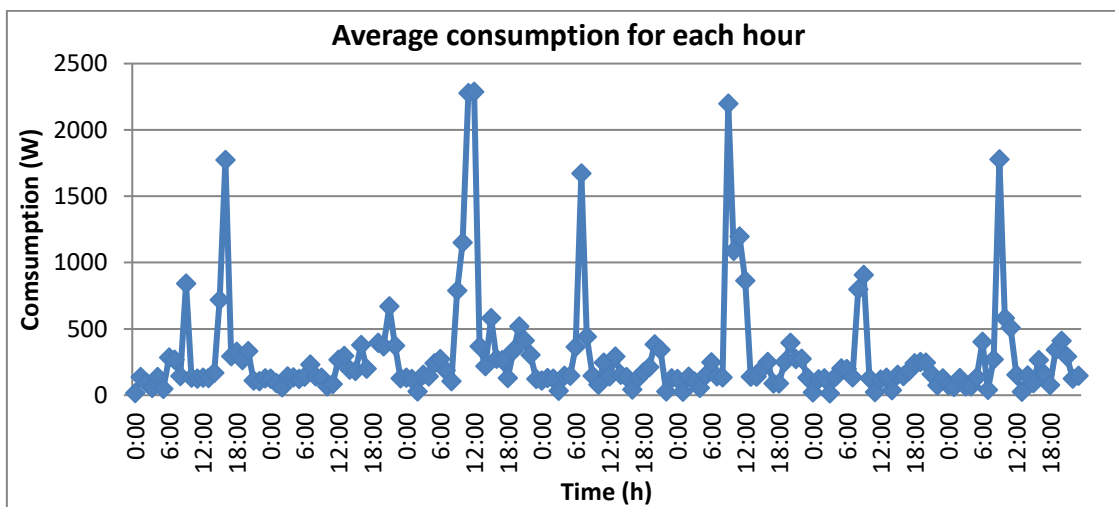

Figure 6: Average consumption for each hour



Then, we have calculated the average consumption for each hour. These results are in Figure 6. Here, we can also see the same behavior as in the initial measurement, with the highest values of consumption in the mornings.

Finally, we can calculate the consumption of a typical day in the week and in the weekend. For calculating the typical day's consumption in the weekend, we have made the average between the loads of Saturday 2nd and Sunday 3rd of September. This data are shown in Figure 7 and in Table 1

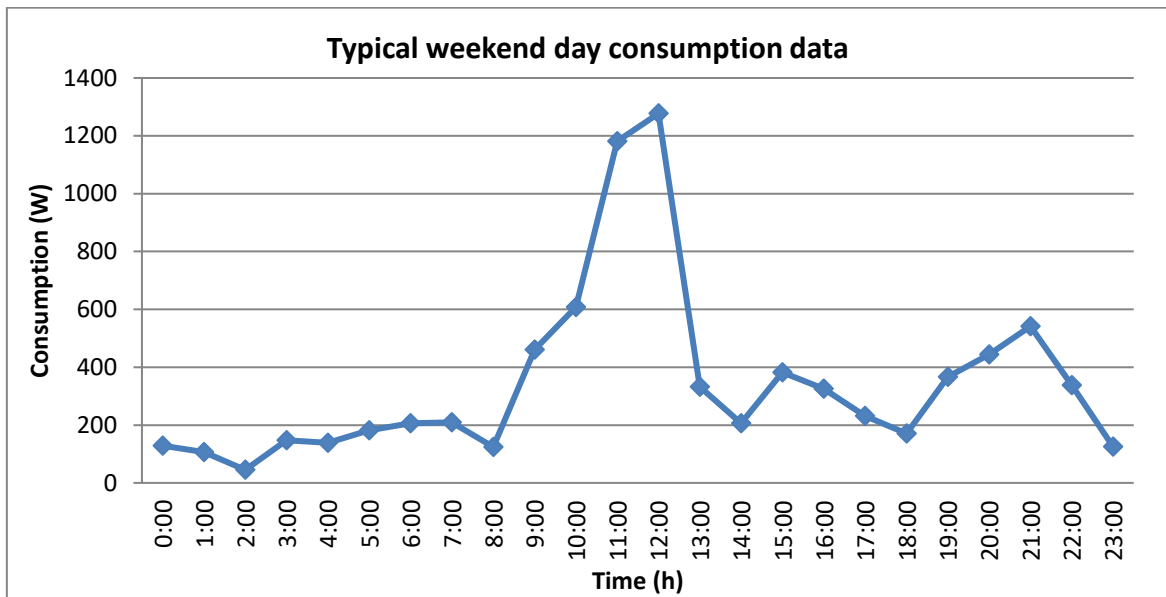

Figure 7: Consumption values of our typical day in the weekend

For the typical day's consumption in the week, we have calculated the average between the other of days. The results are presented in Figure 8 and in Table 1.

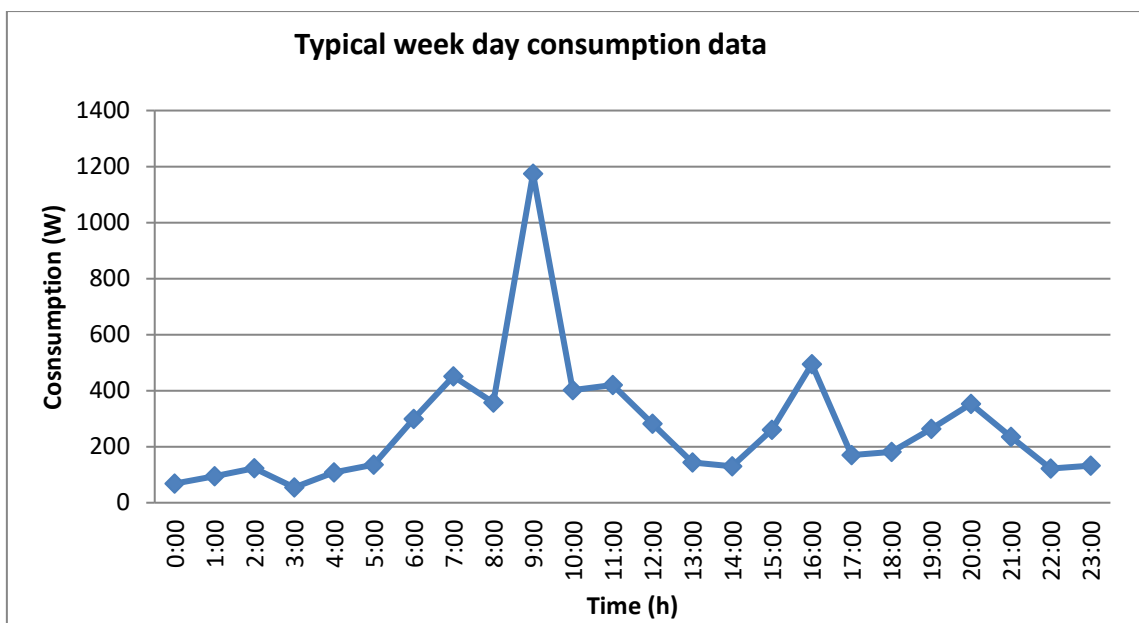

Figure 8: Consumption values of our typical day in the week



Table 1: Consumption vaones of our typical day in the weekend and in the week

Time	Average weekday (Wh)	Average weekend day (Wh)
0:00:00	129.10	68.72
1:00:00	106.67	95.07
2:00:00	45.14	122.91
3:00:00	147.89	54.58
4:00:00	138.25	108.71
5:00:00	181.65	135.80
6:00:00	205.71	299.07
7:00:00	209.58	451.00
8:00:00	123.82	357.81
9:00:00	460.38	1174.42
10:00:00	608.32	401.76
11:00:00	1180.82	419.79
12:00:00	1277.14	282.14
13:00:00	331.82	143.60
14:00:00	205.61	130.09
15:00:00	381.81	259.97
16:00:00	326.16	495.02
17:00:00	231.74	169.89
18:00:00	171.00	181.10
19:00:00	366.73	264.00
20:00:00	444.05	353.28
21:00:00	541.08	235.18
22:00:00	338.14	121.62
23:00:00	125.62	132.75

Now we have calculated the consumption of a typical day in the week and on the weekend and we can introduce this data in the software HOMER for doing our simulation and designing our PV system.

4. SYSTEM MODELING IN HOMER

In this chapter, we are going to proceed with the simulation of our installation in the software HOMER. First, we are explaining the different steps followed for doing the simulation and after we are going to analyze the results given by the software.

For doing the simulation, we have to model the different components of the installation: the load, the PV panels, the batteries and the inverter.

4.1. Load modeling

For modeling the load, first we have introduced the values of consumption calculated for a typical day in the week (Figure 9) and in the weekend (Figure 10). We introduce the same values for each month.

Hour	Weekdays											
	January	February	March	April	May	June	July	August	September	October	November	December
0	0.069	0.069	0.069	0.069	0.069	0.069	0.069	0.069	0.069	0.069	0.069	0.069
1	0.095	0.095	0.095	0.095	0.095	0.095	0.095	0.095	0.095	0.095	0.095	0.095
2	0.123	0.123	0.123	0.123	0.123	0.123	0.123	0.123	0.123	0.123	0.123	0.123
3	0.055	0.055	0.055	0.055	0.055	0.055	0.055	0.055	0.055	0.055	0.055	0.055
4	0.109	0.109	0.109	0.109	0.109	0.109	0.109	0.109	0.109	0.109	0.109	0.109
5	0.136	0.136	0.136	0.136	0.136	0.136	0.136	0.136	0.136	0.136	0.136	0.136
6	0.299	0.299	0.299	0.299	0.299	0.299	0.299	0.299	0.299	0.299	0.299	0.299
7	0.451	0.451	0.451	0.451	0.451	0.451	0.451	0.451	0.451	0.451	0.451	0.451
8	0.358	0.358	0.358	0.358	0.358	0.358	0.358	0.358	0.358	0.358	0.358	0.358
9	1.174	1.174	1.174	1.174	1.174	1.174	1.174	1.174	1.174	1.174	1.174	1.174
10	0.402	0.402	0.402	0.402	0.402	0.402	0.402	0.402	0.402	0.402	0.402	0.402
11	0.420	0.420	0.420	0.420	0.420	0.420	0.420	0.420	0.420	0.420	0.420	0.420
12	0.282	0.282	0.282	0.282	0.282	0.282	0.282	0.282	0.282	0.282	0.282	0.282
13	0.144	0.144	0.144	0.144	0.144	0.144	0.144	0.1435975	0.144	0.144	0.144	0.144
14	0.130	0.130	0.130	0.130	0.130	0.130	0.130	0.130	0.130	0.130	0.130	0.130
15	0.260	0.260	0.260	0.260	0.260	0.260	0.260	0.260	0.260	0.260	0.260	0.260
16	0.495	0.495	0.495	0.495	0.495	0.495	0.495	0.495	0.495	0.495	0.495	0.495
17	0.170	0.170	0.170	0.170	0.170	0.170	0.170	0.170	0.170	0.170	0.170	0.170
18	0.181	0.181	0.181	0.181	0.181	0.181	0.181	0.181	0.181	0.181	0.181	0.181
19	0.264	0.264	0.264	0.264	0.264	0.264	0.264	0.264	0.264	0.264	0.264	0.264
20	0.353	0.353	0.353	0.353	0.353	0.353	0.353	0.353	0.353	0.353	0.353	0.353
21	0.235	0.235	0.235	0.235	0.235	0.235	0.235	0.235	0.235	0.235	0.235	0.235
22	0.122	0.122	0.122	0.122	0.122	0.122	0.122	0.122	0.122	0.122	0.122	0.122
23	0.133	0.133	0.133	0.133	0.133	0.133	0.133	0.133	0.133	0.133	0.133	0.133

Figure 9: Consumption values of our typical day in the week in HOMER

Weekdays		Weekends										
Hour	January	February	March	April	May	June	July	August	September	October	November	December
0	0.129	0.129	0.129	0.129	0.129	0.129	0.129	0.129	0.129	0.129	0.129	0.129
1	0.107	0.107	0.107	0.107	0.107	0.107	0.107	0.107	0.107	0.107	0.107	0.107
2	0.045	0.045	0.045	0.045	0.045	0.045	0.045	0.045	0.045	0.045	0.045	0.045
3	0.148	0.148	0.148	0.148	0.148	0.148	0.148	0.148	0.148	0.148	0.148	0.148
4	0.138	0.138	0.138	0.138	0.138	0.138	0.138	0.138	0.138	0.138	0.138	0.138
5	0.182	0.182	0.182	0.182	0.182	0.182	0.182	0.182	0.182	0.182	0.182	0.182
6	0.206	0.206	0.206	0.206	0.206	0.206	0.206	0.206	0.206	0.206	0.206	0.206
7	0.210	0.210	0.210	0.210	0.210	0.210	0.210	0.210	0.210	0.210	0.210	0.210
8	0.124	0.124	0.124	0.124	0.124	0.124	0.124	0.124	0.124	0.124	0.124	0.124
9	0.460	0.460	0.460	0.460	0.460	0.460	0.460	0.460	0.460	0.460	0.460	0.460
10	0.608	0.608	0.608	0.608	0.608	0.608	0.608	0.608	0.608	0.608	0.608	0.608
11	1.181	1.181	1.181	1.181	1.181	1.181	1.181	1.181	1.181	1.181	1.181	1.181
12	1.277	1.277	1.277	1.277	1.277	1.277	1.277	1.277	1.277	1.277	1.277	1.277
13	0.332	0.332	0.332	0.332	0.332	0.332	0.332	0.332	0.332	0.332	0.332	0.332
14	0.206	0.206	0.206	0.206	0.206	0.206	0.206	0.206	0.206	0.206	0.206	0.206
15	0.382	0.382	0.382	0.382	0.382	0.382	0.382	0.382	0.382	0.382	0.382	0.382
16	0.326	0.326	0.326	0.326	0.326	0.326	0.326	0.326	0.326	0.326	0.326	0.326
17	0.232	0.232	0.232	0.232	0.232	0.232	0.232	0.232	0.232	0.232	0.232	0.232
18	0.171	0.171	0.171	0.171	0.171	0.171	0.171	0.171	0.171	0.171	0.171	0.171
19	0.367	0.367	0.367	0.367	0.367	0.367	0.367	0.367	0.367	0.367	0.367	0.367
20	0.444	0.444	0.444	0.444	0.444	0.444	0.444	0.444	0.444	0.444	0.444	0.444
21	0.541	0.541	0.541	0.541	0.541	0.541	0.541	0.541	0.541	0.541	0.541	0.541
22	0.338	0.338	0.338	0.338	0.338	0.338	0.338	0.338	0.338	0.338	0.338	0.338
23	0.126	0.126	0.126	0.126	0.126	0.126	0.126	0.126	0.126	0.126	0.126	0.126

Figure 10: Consumption values of our typical day in the week in HOMER

After introducing our data, HOMER processes them and models a daily consumption profile (Figure 11). In the graphic below, we can see that the consumption values start to grow in the morning, when the day begins and it obtains the highest values at nine. After that, it starts to decrease until the midnight, when we obtain the lowest values. As we perceive we have the same behavior than in our analysis of the consumption data.

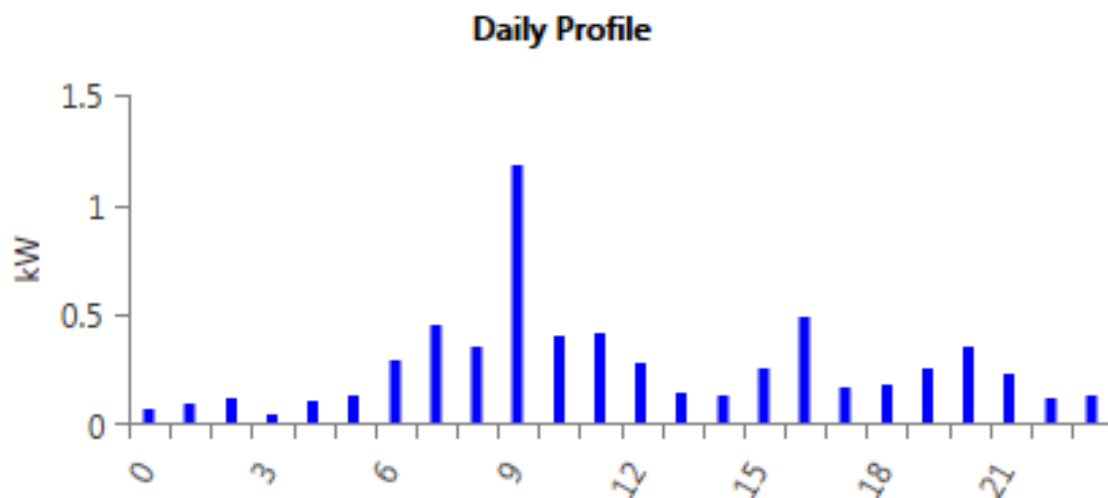

Figure 11: Daily load profile

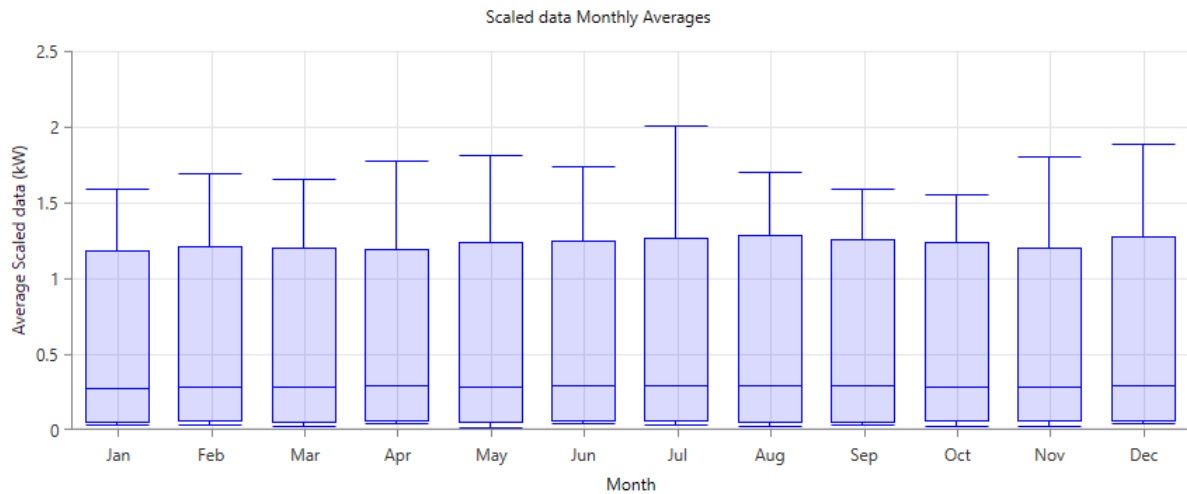

Figure 12: Monthly load profile

HOMER also designs a monthly load profile introducing variation in the consumption for each month (Figure 12).

In the Figure 13, we can see the modeling of the yearly load profile done by HOMER. On the horizontal axis, we have each day of the year from one to 365. In the left vertical axis, we have the hours of the day from 0 to 24. Inside the graphic, we have different colors assigned by the scale situated in the right side. For each position of the graphic these colors give us the value of the consumption in each hour of each day of the year.

In the graphic, we perceive another time that the highest values are in the morning.

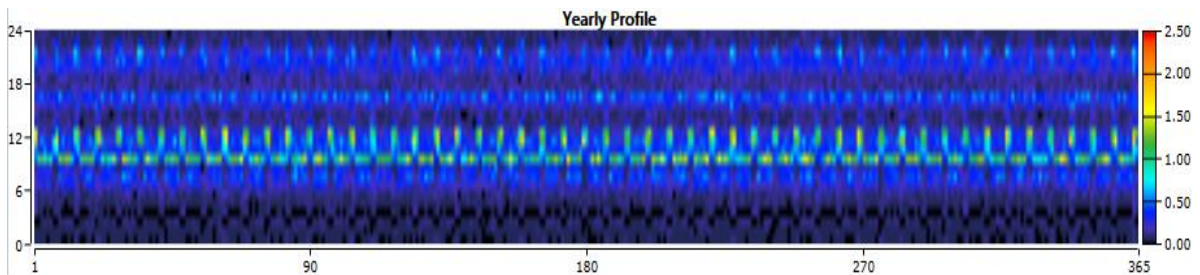

Figure 13: Yearly load profile

4.2. PV Modeling

After the load, we have modeled the PV panels with HOMER.

The first thing we have to do is to get the solar resources for our location. For this, HOMER has a tool where you introduce your location, in our case it is Osijek, and it obtains the solar data from the NASA database. It also can give you temperature and wind data, but we do not need it in our case.

Once we have introduced our location and HOMER has downloaded the solar resources we have to introduce the data of the PV panels.

The chosen PV module is Generic flat plate PV, whose properties are in Figure 14.

Properties	
Name:	Generic flat plate PV
Abbreviation:	PV
Panel Type:	Flat plate
Rated Capacity (kW):	0
Manufacturer:	Generic
Weight (lbs):	160
Footprint (in ²):	9000
Website:	www.homerenergy.com
Notes:	This is a generic PV system.

Figure 14: PV module properties

Then we introduced the cost of the PV modules. In HOMER, we need to introduce the capital, the replacement and the O&M costs for each kW of PV capacity installed for all components.

We have calculated the cost of the PV module and the inverter taking the data from the PV status report of 2017 [14] and from the PV status report of 2014 [15].

Table 2: PV costs from PV status report 2017 [14]

Concept	Price (€/kWp)
Hardware	850
Engineering and installation	280
Other (fees, insurances, permits...)	170
Total	1,300

In Table 2, we have the data of PV costs in the year 2017. Although, there we haven't specified the costs of the different components of the installation, all the component costs are included in the hardware category. For getting the separated costs, we are going to use the report of 2014 (Table 3) where the prices for the different components are specified. Then, we are going to calculate which percentage supposes each component over the installation and to apply them to the total price calculated for the year 2017.

Table 3: PV costs from PV status report 2014 [15]

Concept	Price (€/kWp)
PV module	560
Inverter	140
Balance of system	270
Engineering, procurement and construction	300
Other	130
Total	1,400

First, taking the data of 2014 we have to calculate the percentage of each component in share of total price. We are not going to take account the *Balance of systems* cost, because this process is done only in on-grid installations. This cost is 270 € and supposes a 19% over the total price of 1,400 €. Consequently, we are going to subtract it from the total price, which after that is about 1,130€. Then we have calculated which percentage supposes each of the rest of the components over our final price of 1,130 €. We can see the values in Table 4.

Table 4: Percentage of each cost over the total price

Concept	Cost	Percentage over the total (€/kWp)
PV module	560	49.56%
Inverter	140	12.39%
Engineering, procurement and construction	300	26.55%
Other	130	11.50%

Once we have the percentages, we take the total price of 2017, which is 1,300 €. First, we have to extract from the total price the proportional part of the Balance of systems cost. As we have calculated before, this cost was a 19% over the total in 2014. If we apply this percentage to the total in 2017, it is 250 €. Then, we subtract this price from the total and our final total cost for the year 2017 is 1,050 €.

Then, we apply the percentages in Table 4 over the total price in 2017, to get the proportional cost of each concept on this year. In Table 5, we observe the result.

Table 5: Proportional costs in 2017

Concept	Percentage over the total	Cost (€/kWp)
PV module	49.56%	520
Inverter	12.39%	130
Engineering, procurement and construction	26.55%	279
Other	11.50%	121

When we have our costs for the year 2017, we are going to add the costs of engineering, procurement and construction and the other concept costs. The value is about 400 €. Then we apply this cost to the PV module and to the inverter. We are going to add a 10% of this cost to the inverter, and the rest of it to the PV modules. The final costs of both components in the year 2017 are in Table 6.

Table 6: Total cost of the inverter and the PV module in 2017

Element	Cost element (€/kWp)	Engineering and other concepts (€/kWp)	Total cost (€/kWp)
PV module	520	360	880
Inverter	130	40	170

The calculated cost is the capital and the replacement cost of 1 kW of each device. The O&M cost will be a 2% of the capital cost.

Finally, we can introduce the data in HOMER (Figure 15).

Costs			
Capacity (kW)	Capital (€)	Replacement (€)	O&M (\$/year)
1	€880.00	€880.00	€17.60

Figure 15: PV flat costs in HOMER

Then, we have to introduce the size of the photovoltaic field. In our case, we are not going to do it, because HOMER can obtain the most optimized size for our PV system. Consequently, we choose the option of HOMER Optimizer.

4.3. Inverter modeling

Then we have to model the inverter. The model chosen is the System Converter. Its properties are in Figure 16.

- Properties	
Name:	System Converter
Abbreviation:	Converter
Manufacturer:	Generic
Weight (lbs):	1500
Footprint (in2):	2000
Website:	www.homerenergy.com
Notes:	This is a generic system converter.

Figure 16: Inverter properties



After, we introduce the cost data calculated in the previous subchapter. In Figure 17, we have the data introduced in HOMER.

Costs			
Capacity (kW)	Capital (€)	Replacement (€)	O&M (\$/year)
1	€170.00	€170.00	€3.40

Figure 17: Inverter cost in 2017

As in the photovoltaic field, we are not going to size the inverter and choose the option of HOMER Optimizer.

We have introduced the data of the inverter, now we can continue with the batteries.

4.4. Battery modeling

Then we add the battery. The chosen battery is a Generic 1kWh lead acid battery. The properties of the battery are in Figure 18.

Properties
Name: Generic 1kWh Lead Acid
Abbreviation: 1kWh LA
Manufacturer: Generic
Nominal Voltage (V): 12.0
Maximum Capacity (Ah): 83.4
Round Trip Efficiency (%): 80.0
Float Life (years): 10.0
Suggested Life Throughput (kWh): 800
Electrolyte replacement interval (yrs): 0.00
Capacity Ratio, c: 0.403
Rate Constant, k: 0.827
Max. Charge Rate (A/Ah): 1.00
Max. Charge Current (A): 16.7
Max. Discharge Current (A): 24.3
Weight (lbs): 25.0
Volume (in ³): 0.0125
Footprint (in ²): 0.0500
Website: www.homerenergy.com

Figure 18: Battery properties

For obtaining the price of the battery, we have checked in the web Solar Shop [16] the price of a lead battery of 8.5 Ah. The cost is about 750 kn., which is 100 € approximately. This is the capital and the replacement cost. For the O&M cost, we have calculated the 2% of the capital cost. The Figure 19 shows the values of the costs introduced in HOMER.

Costs			
Quantity	Capital (€)	Replacement (€)	O&M (\$/year)
1	€100.00	€100.00	€2.00

Figure 19: Battery costs

Then, as in the other cases, we are not going to size the number of batteries because we chose the option of HOMER Optimizer.

Now, we have modeled all the elements. Before doing the simulation, we are going to add different values of the maximum annual capacity shortage. The capacity shortage expresses the percentage of moments in a year when our installation cannot give the total power required by the loads.

We have done values from 0% to 5% as we see in Figure 20.

Variable: Capacity Shortage (%)

Link with: <none>

Values:

Capacity Shortage (%)
0
1
2
3
4
5

Figure 20: Capacity shortage

After that, we can press the HOMER's button of calculation and turn on the simulation.

5. RESULTS OF THE SIMULATION IN HOMER

In this chapter, we are going to analyze the results of the simulation given by HOMER.

First, HOMER gives us the table below (Figure 21), it shows the optimal solution for each value of capacity shortage.

Sensitivity	Architecture						Cost				System	
Capacity Shortage (%)				PV (kW)	1kWh LA	Converter (kW)	Dispatch	COE (€)	NPC (€)	Operating cost (€)	Initial capital (€)	Ren Frac (%)
0				7.69	44	3.82	CC	€0.561	€18,455	€513.55	€11,816	100
1				6.12	39	2.94	CC	€0.474	€15,471	€439.50	€9,789	100
2				7.47	24	3.45	CC	€0.435	€14,070	€348.67	€9,563	100
3				7.10	20	1.95	CC	€0.388	€12,434	€298.49	€8,576	100
4				5.21	23	2.60	CC	€0.350	€11,135	€294.28	€7,331	100
5				5.57	18	1.87	CC	€0.327	€10,319	€255.21	€7,020	100

Figure 21: Simulation results

To observe better the influence of the capacity shortage in the costs and in the components, we have represented the data in some graphics.

In Figure 22 we can see the NPC and the Initial Capital versus of the capacity shortage. The Total Net Present cost (NPC) of a system is the present value of all the costs the system incurs over its lifetime, minus the present value of all the revenue it earns over its lifetime [17]. The Initial Capital of a component is the total installed cost of that component at the beginning of the project [18].

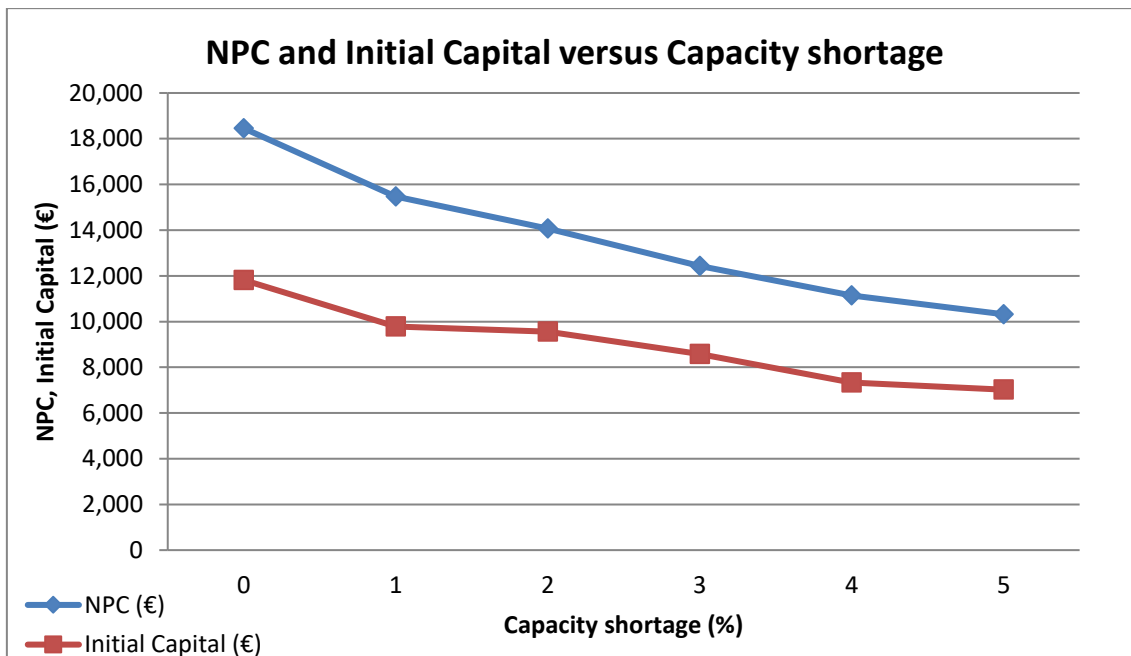

Figure 22: NPC and Initial capital versus Capacity shortage

We can appreciate that as higher is the capacity shortage as lower are the costs. Also, we realize in Figures 21 and 22 that, like we are using high quantities, the savings are really

high if we have a higher percentage of capacity shortage. With a 5% of capacity shortage we save 4,796 € in the initial capital and 8,160 € in the NPC respect a capacity shortage of 0%.

In Figure 22 we can see the COE and operating costs versus the capacity shortage. The Cost of Energy (COE) is the average cost per kWh of useful electrical energy produced by the system [19]. The Operating Cost is the annualized value of all costs and revenues other than initial capital costs [20].

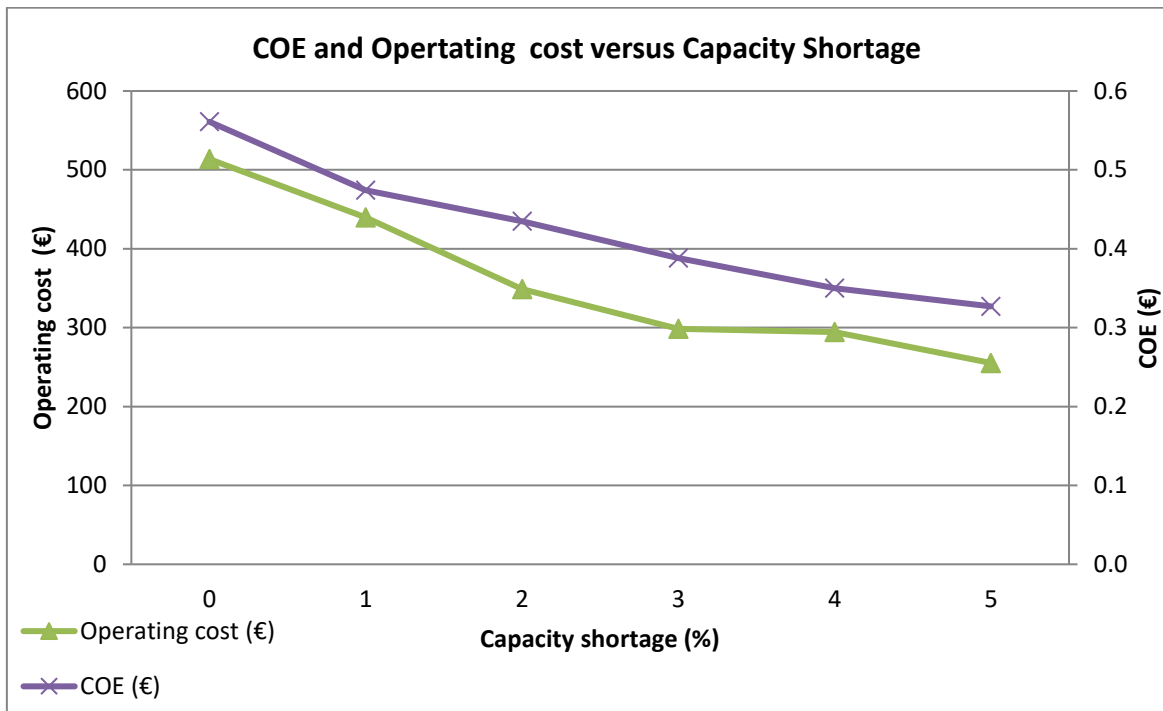

Figure 23: COE and Operating cost versus Capacity shortage

In Figures 21 and 23 we can realize also that with a higher percentage of capacity shortage the cost of generating each kWh of energy is lower, being 0.561 with a capacity shortage of 0% and 0.327 with a 5%. In the operating cost there is also a difference of 258.34 € between the higher and lower value of capacity shortage.

In Figure 24 we can see the variations caused by the capacity shortage in the quantity of batteries and in the PV and the converter installed power.

As we perceive in the data of the three components, their behavior is not always decreasing while the capacity shortage grows. For example, in the solution for a 2% percentage of capacity shortage the PV and the converter power are higher than in the solution for a 1% of capacity shortage, but, if we realize we can find a big decrease in the batteries, that balances the costs. This happens because HOMER analyzes all possible configurations and chooses the cheapest configuration to give the less total quantity of installed elements and power.

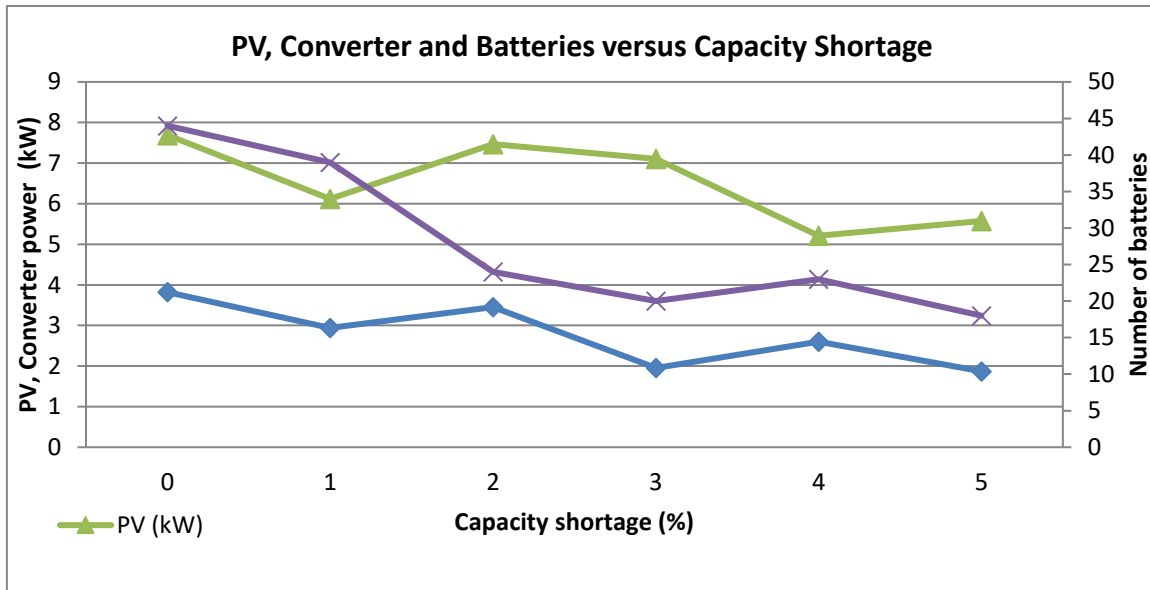

Figure 24: PV, Converter and Batteries versus Capacity Shortage

In summary, as we can appreciate, when the percentage of the capacity shortage grows the total installed power of the elements of the installation can be lower. Consequently, when the capacity shortage grows the costs decrease. If we add all the cost for a capacity shortage value of 0% the total cost would be 30,785.11 €. For a capacity shortage of 5% it would be 17,594.54 €. That supposes a saving of 13,190.11 €. So we can appreciate that having a low value of capacity shortage as 5% we can save a lot of money and the quantity of lacks during a whole year is not going to be high. In summary, for designing our installation we have to make a balance between: on one hand, saving money and have a little percentage of lacks of energy for the loads, or on the other, to accomplish the consume requirements during all year but have higher costs.

Now, we are going to analyze each capacity shortage's optimal solution in a separated way.

5.1. Optimal solution for a 0% of capacity shortage

Figure 25 shows the summary of the cost of the chosen solution. There, we can appreciate that the cheapest component is the converter, with a big difference with the PV module and the batteries, which are the most expensive.

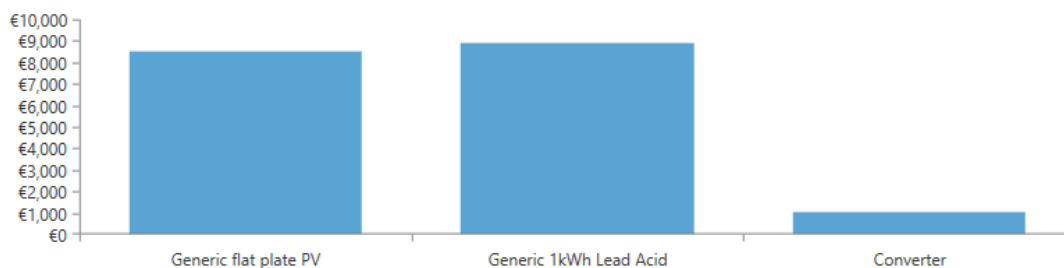

Figure 25: Cost of each component for capacity shortage 0%

In Figure 26, we see the cash flow during 25 years divided by the type of cost and in Figure 27 divided in components.

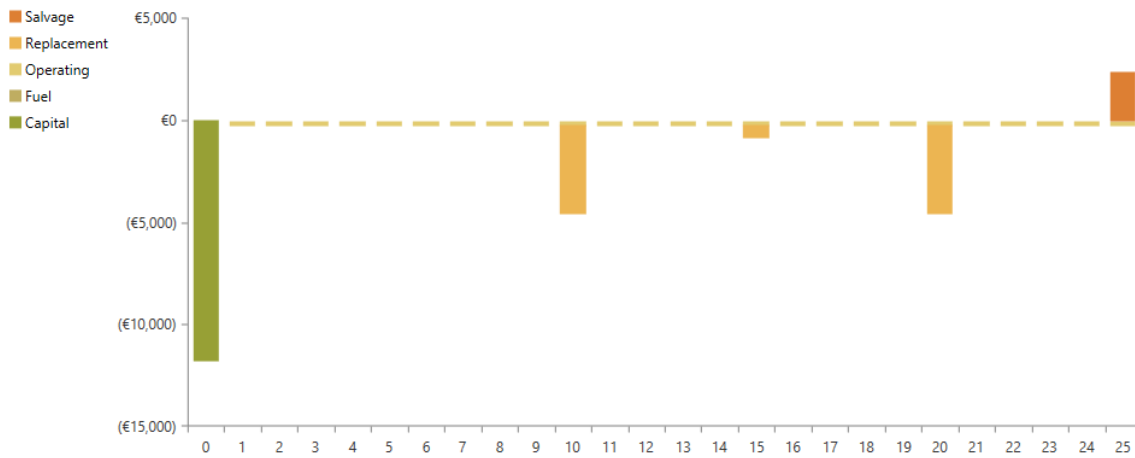

Figure 26: Cash costs for different costs for capacity shortage 0%

We can see the high initial investment is in green, with a value about 12,000 €. We can appreciate also, that the highest part of this initial cost is for the PV modules, a little part of the converter and the rest of the batteries. Each year, we have the operating cost of the PV modules, but it is a low value. Then, we have some replacement cost, each 10 years for the batteries, because this is its expected life, and 15 year a small replacement cost for the PV modules and the converter. Finally, in the year 25 we have salvage.

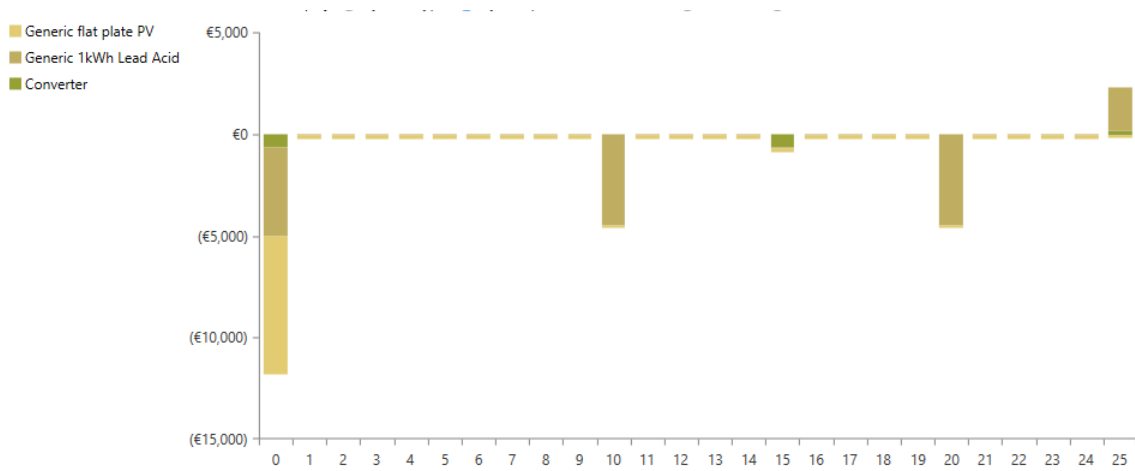

Figure 27: Cash flow divided by the component for capacity shortage 0%

In Figure 28, we have the monthly average electric production modeled by HOMER for our selected location. We can see that the production follows a parabolic shape, reaching the highest values of power in the months of summer, when the solar resource is highest. In addition, we see that in November, December and January the production is really low.

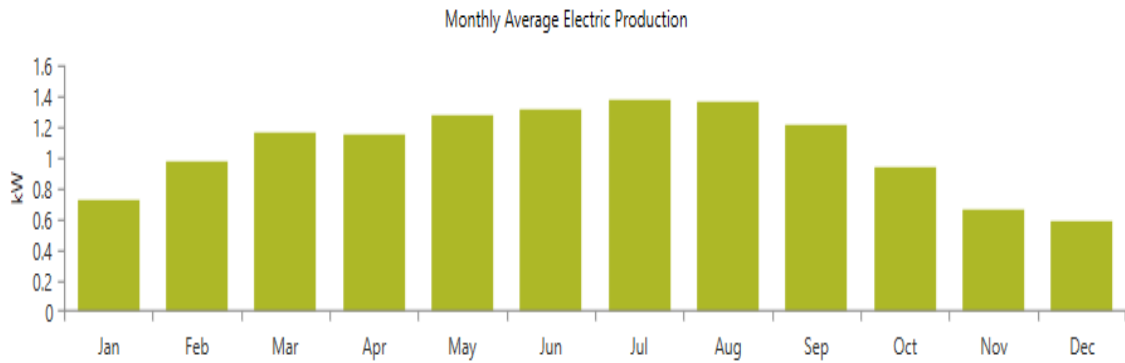

Figure 28: Monthly average electric production for capacity shortage 0%

In Figure 29 we have the instantaneous renewable output divided by the generation. The values are shown for all hours of each day in a year. We have a color scale who gives us the value of the quotient. We can see that in the sun hours this quotient is 100% because all the generated energy comes from the PV system. But, in the night, the value of the quotient is 0%, because neither there is any renewable output nor any generated energy, due to there is not any other energy source besides the sun.

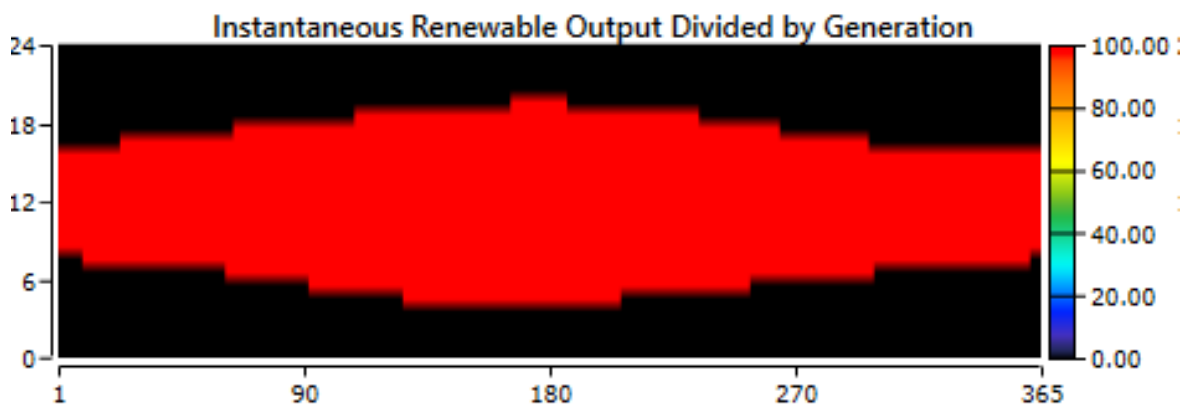

Figure 29: Instantaneous renewable output divided by generation for capacity shortage 0%

In Figures 30 and 31 we have the state of charge of the battery along the year. We see that normally the battery is almost or completely charged, the vast majority of the values are from 80% to 100% of charge. We also can find lower values between 40% and 60% in the winter months.

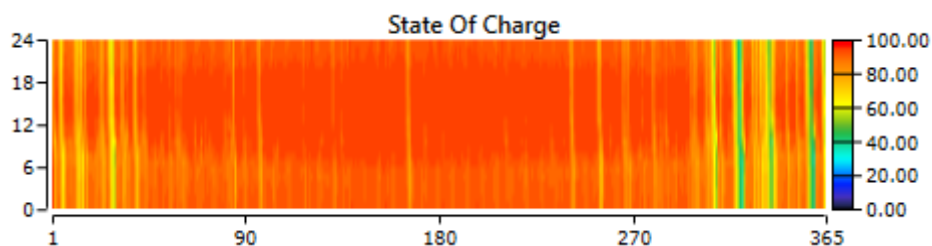

Figure 30: State of charge of the battery in each hour of the year for capacity shortage 0%

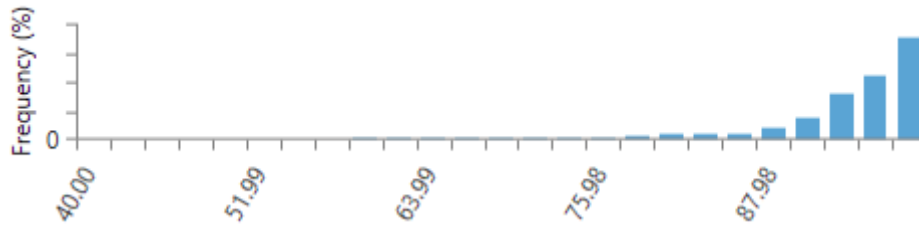

Figure 31: Frequency of each state of charge during the year for capacity shortage 0%

In Figure 32 we see the output power value of the PV system. We appreciate that the highest values of power are given around the noon during all the year and also that the production hours are higher in summer than in winter.

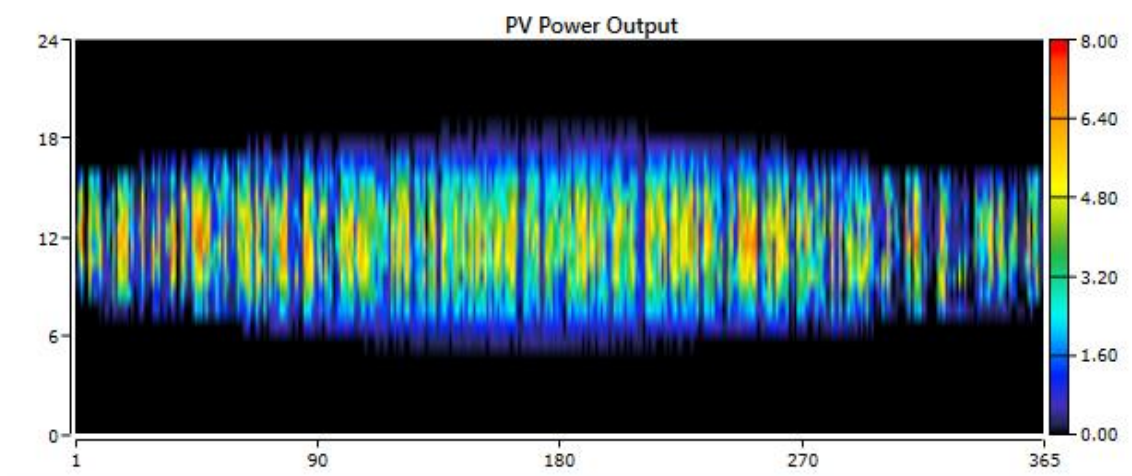

Figure 32: PV power output during the year for capacity shortage 0%

Figure 33 shows the inverter output, which is really low during all year, but we also have higher values around the noon.

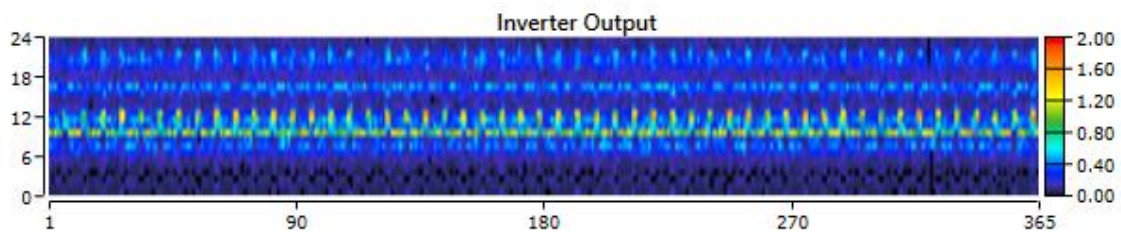

Figure 33: Inverter output during the year for capacity shortage 0%

5.2. Optimal solution for a 1% of capacity shortage

In Figure 34 we see the comparison of the total cost of each component. In this case the difference between the cost of the batteries and the PV modules is higher, because in the optimized solution for this capacity shortage the reduction of the power of PV is bigger

than the reduction of the number of batteries. All components have been reduced and also their costs.

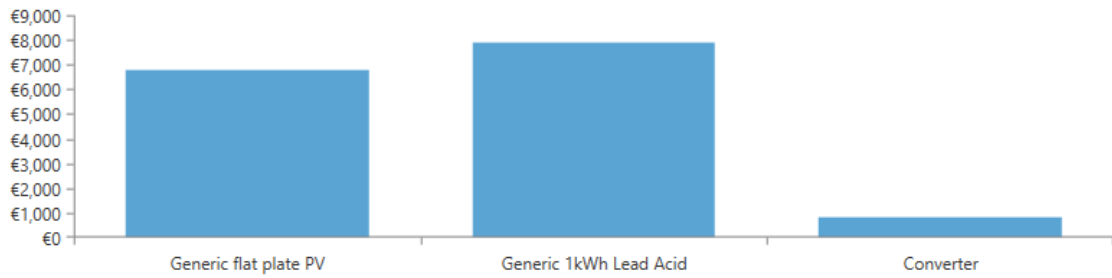

Figure 34: Cost of each component for capacity shortage 1%

The Figures 35 and 36 show the cash flow of the installation, in 35 divided by different types of costs and in 36 in different components. If we compare with the solution for 0% of capacity shortage we can perceive that the distribution of the different type of costs is more or less the same, but the quantities are lower.

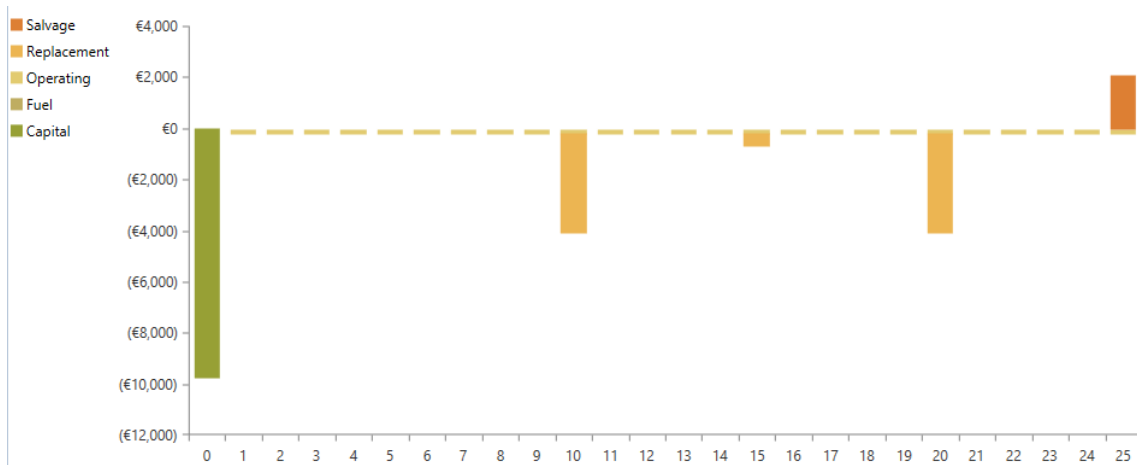

Figure 35: Cash flow divided in different costs for capacity shortage 1%

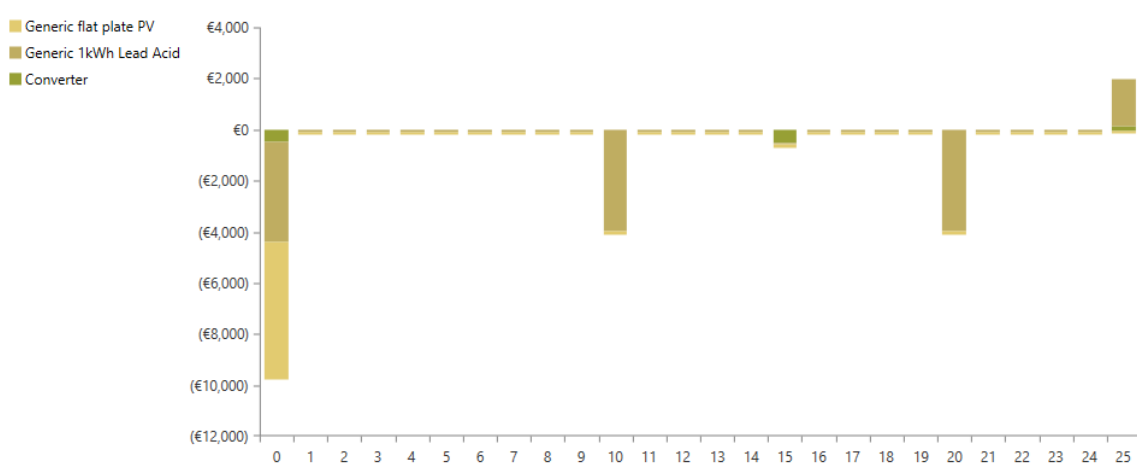

Figure 36: Cash flow divided by the component for capacity shortage 1%

Figure 37 shows the PV average electricity production, which has the same distribution and in the previous solution, but is lower, due to the less PV power installed.

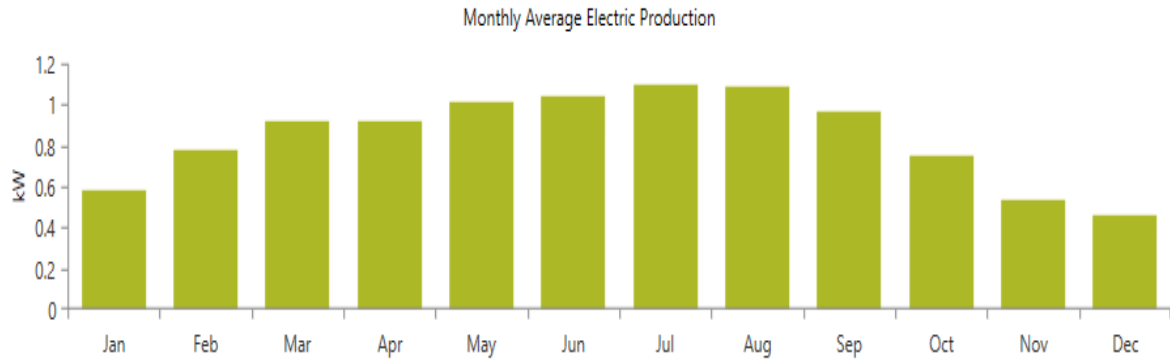

Figure 37: Monthly average electric production for capacity shortage 1%

In Figure 38 there is the instantaneous renewable output divided by generation. This graphic is more or less the same because this quotient does not change when we vary the quantity of installed power.

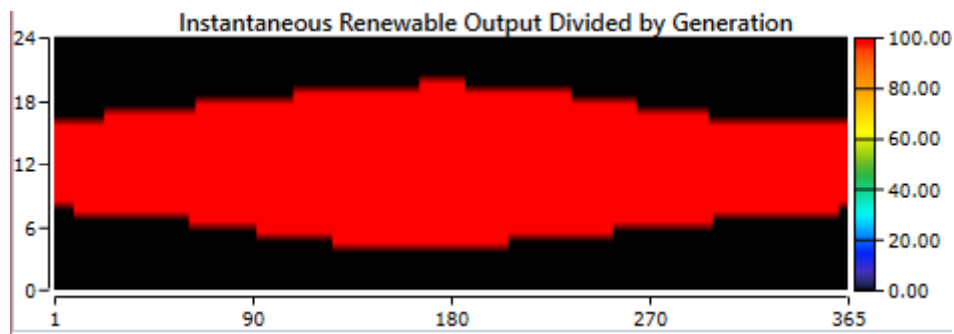

Figure 38: Instantaneous renewable output divided by generation for capacity shortage 1%

Figures 39 and 40 show us the state of charge of the battery. Here we can realize that we have more moments when the batteries are not completely charged. Also, the instants when the state of charge is 40% have grown during the winter months. This is due to the reduction of the PV power, because we do not have enough energy to feed completely the batteries.

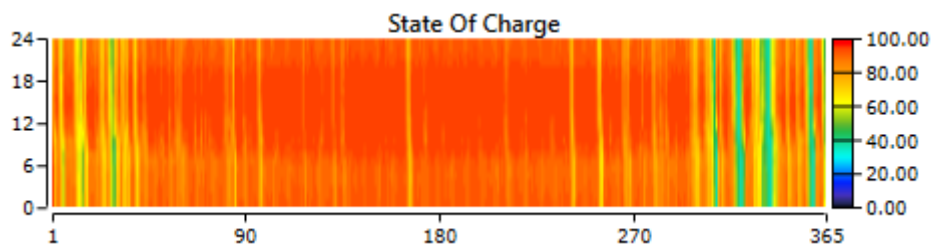

Figure 39: State of charge of the battery in each hour of the year for capacity shortage 1%

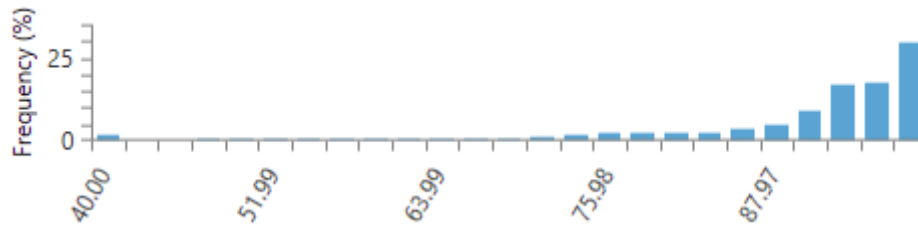

Figure 40: Frequency of each state of charge during the year for capacity shortage 1%

In Figure 41 we see the output power value of the PV system. We can see that the behavior of the production is more or less the same, but the values are lower, before the maximum production was 8 and now it is 7. This happens because of the reduction of PV power.

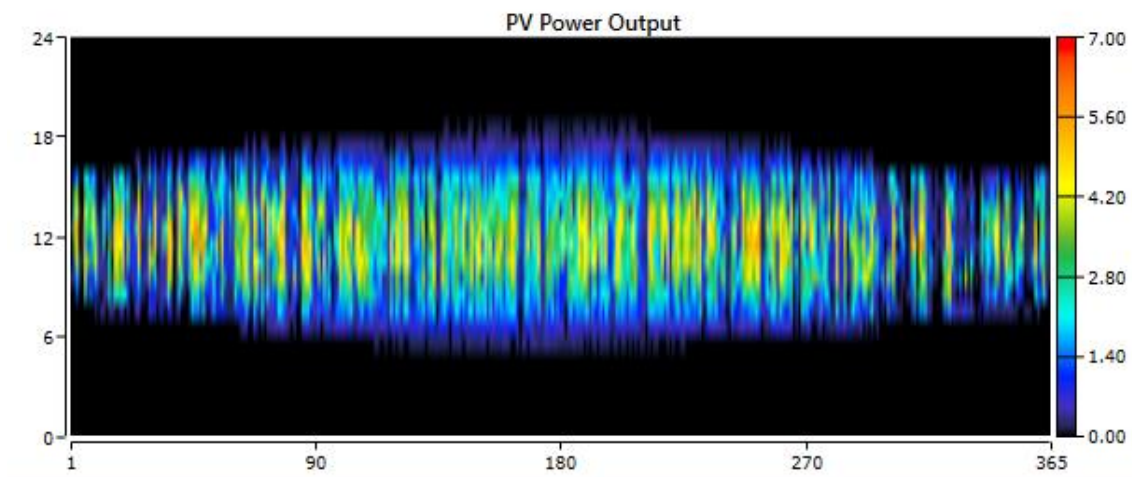

Figure 41: PV power output during the year for capacity shortage 1%

Figure 42 shows the inverter output, which has more or less the same behavior than in the first solution.

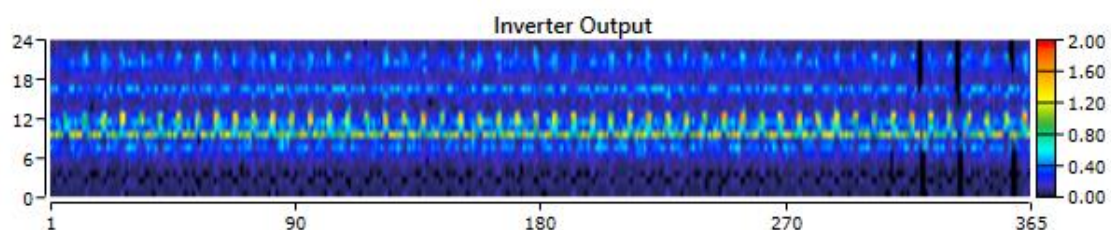

Figure 42: Inverter output during the year for capacity shortage 1%

5.3. Optimal solution for a 2% of capacity shortage

Figure 43 shows the cost of each component for the optimized solution for a value of 2% of capacity shortage. In this case the cost of the PV modules is the highest, with a big difference in the cost of the batteries. This is due to in this solution the power of PV has increased in comparison with the solution for 1% of shortage and the quantity of batteries has decreased. The converter power has grown in this solution, so also the cost.

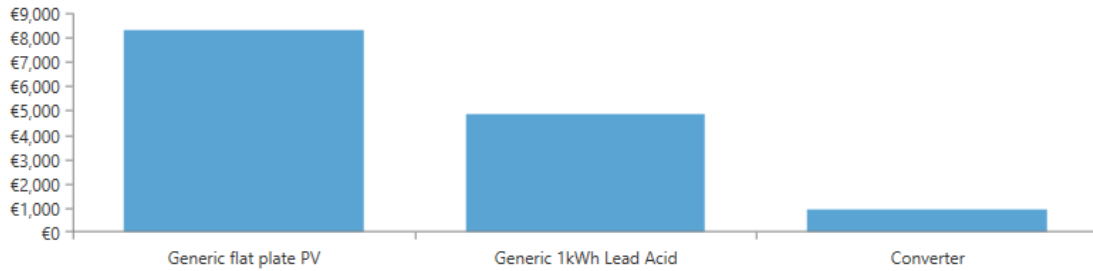

Figure 43: Cost of each component for capacity shortage 2%

In Figure 44 we have the cash flow of these solution separated in costs. We can see that the distribution is more or less than in the previous solutions but all costs are lower. In Figure 45 we have the cash flow in function of components and here another time we appreciate the reduction of the number of batteries and the increase in the PV power.

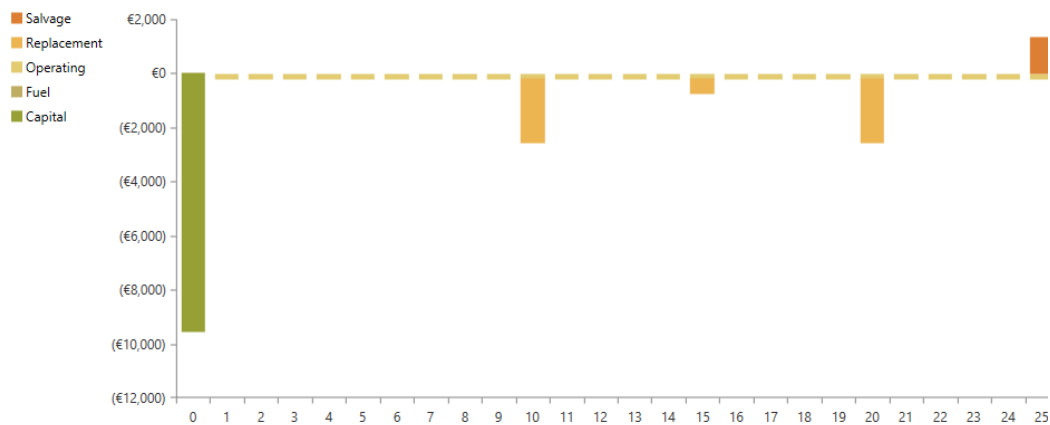

Figure 44: Cash fcosts forded in different costsfor capacity shortage 2%

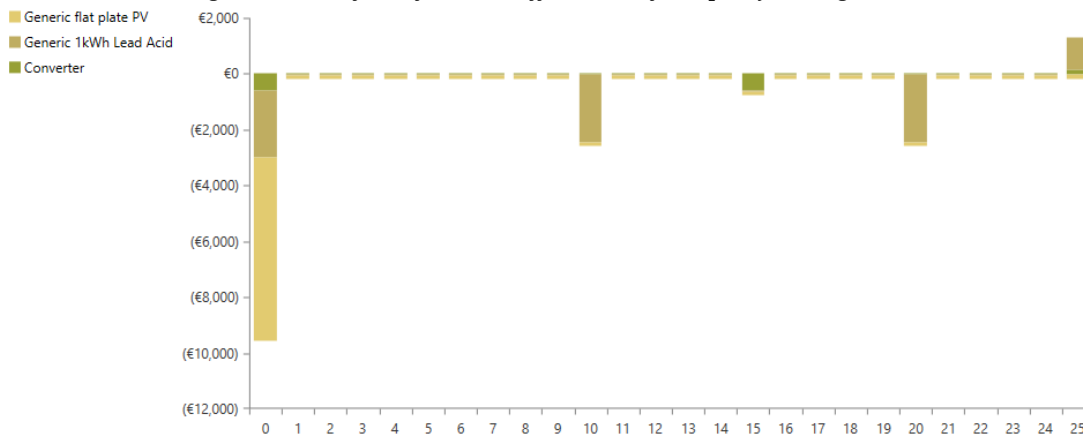

Figure 45: Cash flow divided by the component for capacity shortage 2%

In Figure 46 there is the monthly average PV electricity production, which is higher than in the second solution, because of the increase of the PV power.

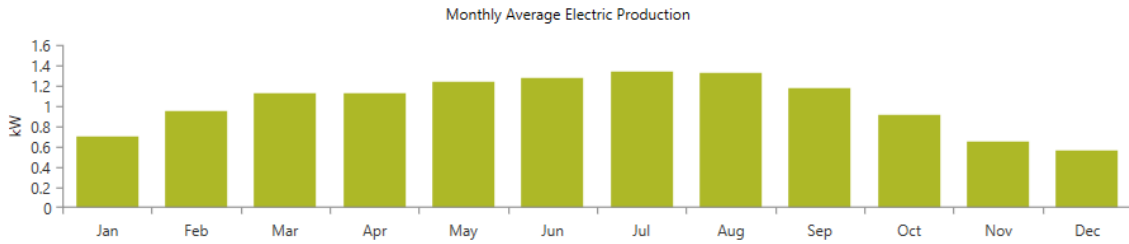

Figure 46: Monthly average electric production for capacity shortage 2%

The instantaneous renewable output divided by the generation does not change, as we appreciate in Figure 47, because it is a quotient and instead of the values vary the quotient is the same because we only have renewable generation.

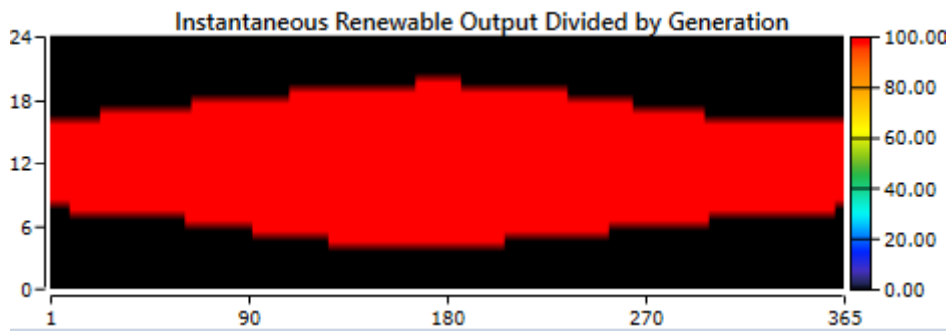

Figure 47: Instantaneous renewable output divided by generation for capacity shortage 2%

The state of charge (Figures 48 and 49) is almost the same than in the second solution, but in this case we have fewer batteries and consequently less days of autonomy.

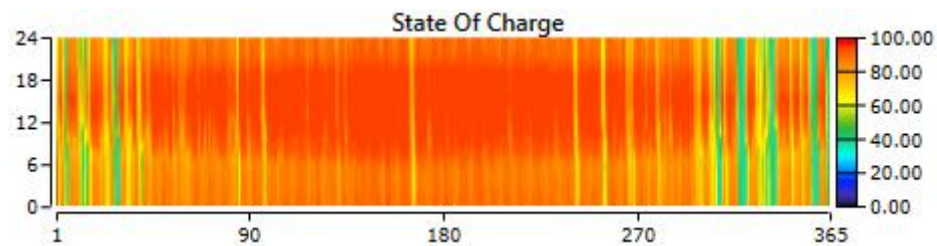

Figure 48: State of charge of the battery in each hour of the year for capacity shortage 2%

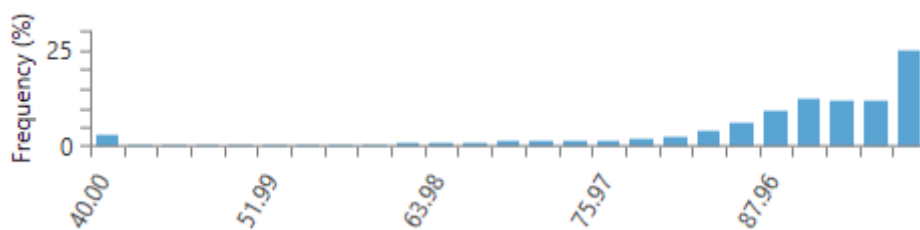

Figure 49: Frequency of each state of charge during the year for capacity shortage 2%

In Figure 50 we have the PV power output, which is lower than in the first solution but higher than in the second.

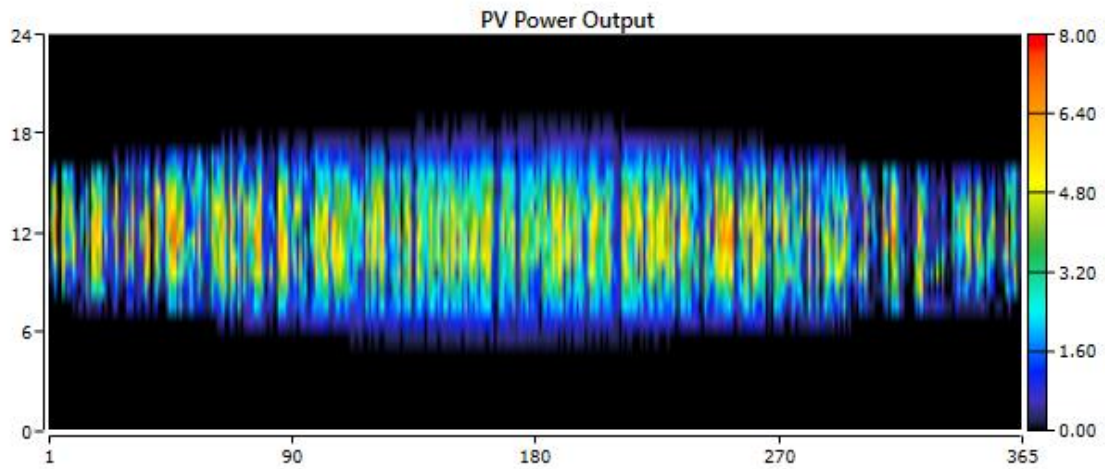

Figure 50: PV power output during the year for capacity shortage 2%

The values in the inverter output (Figure 42) are almost the same than in the other solutions, but we have more moments when the output is zero in the winter months.

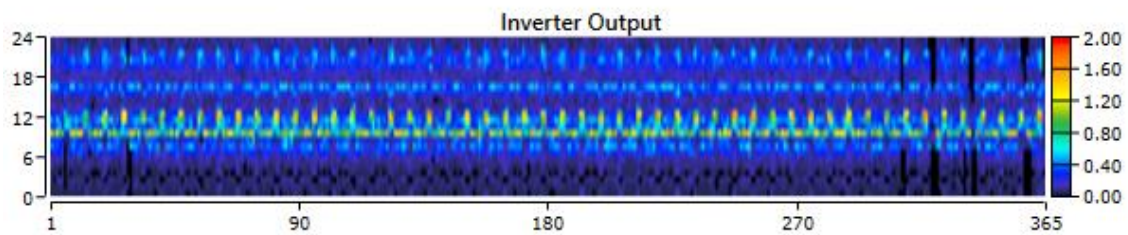

Figure 51: Inverter output during the year for capacity shortage 2%

5.4. Optimal solution for a 3% of capacity shortage

In Figure 52 we have the cost of each component of the solution given for the capacity shortage of 3%. We see that the differences in the cost are more or less the same than in the previous solution. This is because the number of batteries, the PV and the inverter power have decreased more or less in the same grade. Also, we realize that all the prices are lower.

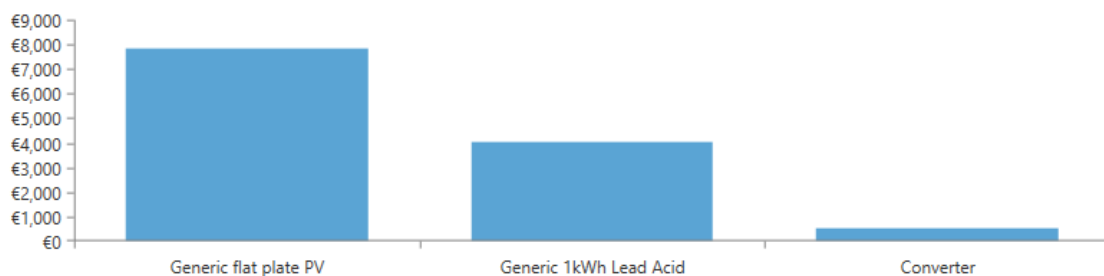

Figure 52: Cost of each component for capacity shortage 3%

In Figure 53 we have the cash flow for this solution in function of the type of cost. The behavior is almost equal than in the other solutions, but obviously the costs are lower.

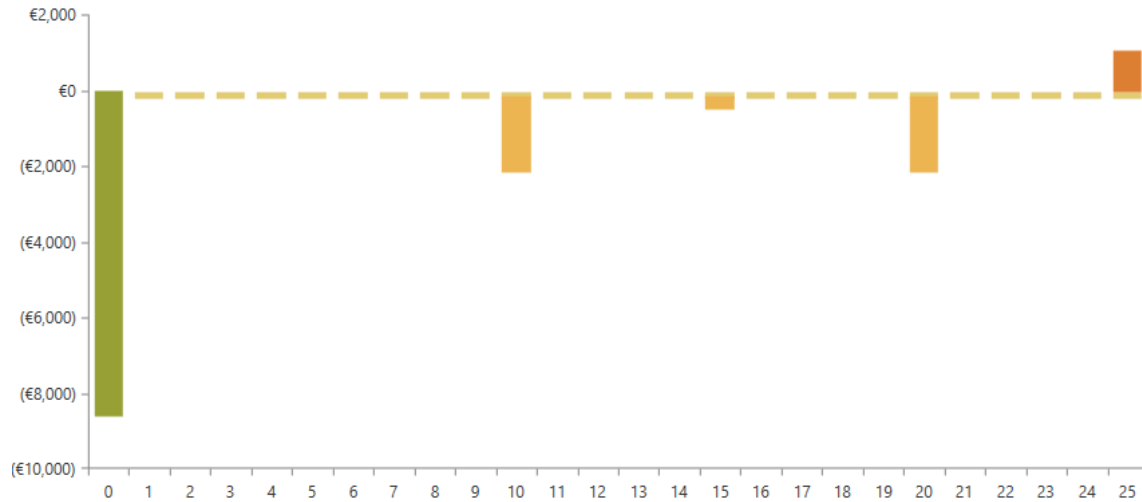

Figure 53: Cash flow divided in different costs for capacity shortage 3%

Figure 54 shows the cash flow for each component of the system. We perceive that as in the solution of 2% of shortage, the high initial cost come from the PV modules.

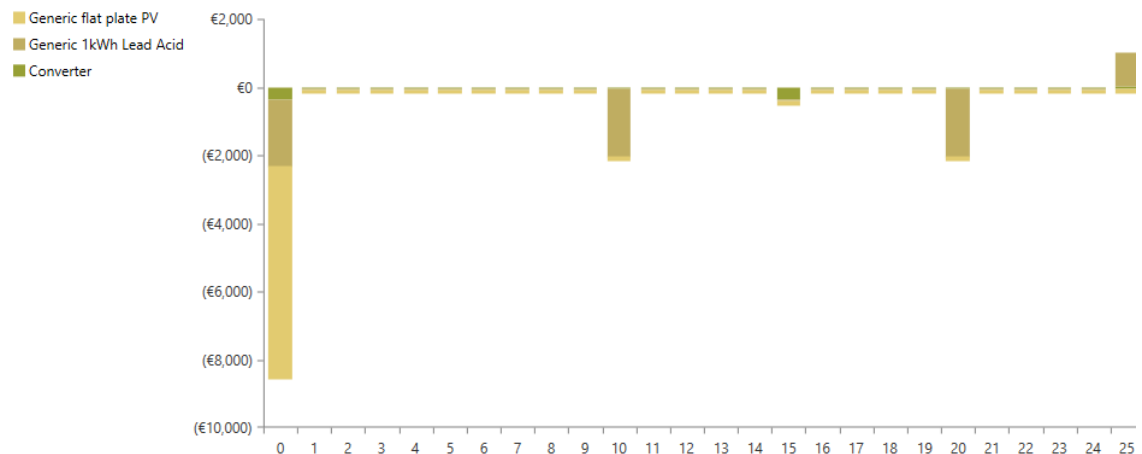

Figure 54: Cash flow divided by the component for capacity shortage 3%

Here (Figure 55) we have the monthly average electricity generated by the PV system. As we have reduced the PV power the electricity production is also lower than before.

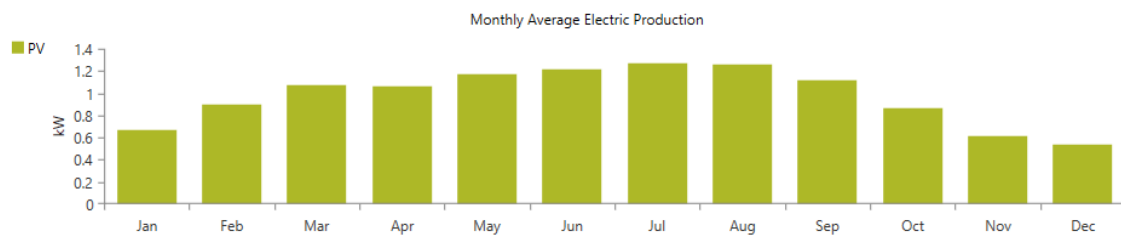

Figure 55: Monthly average electric production for capacity shortage 3%

As in the other solutions the quotient between the renewable output and the generation (Figure 56) does not change.

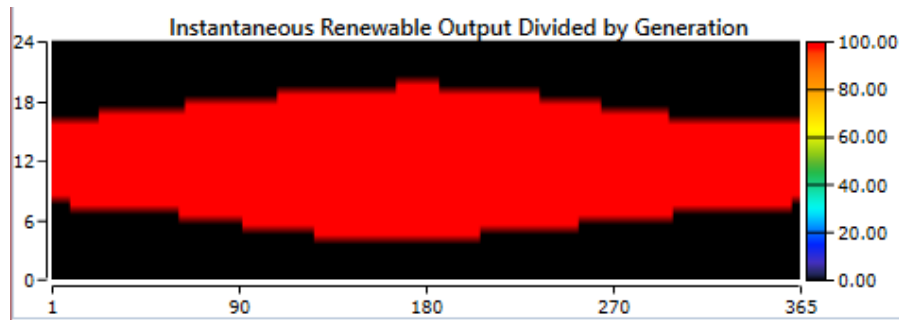

Figure 56: Instantaneous renewable output divided by generation for capacity shortage 3%

In Figures 57 and 58 we have the state of charge. We appreciate that we have more moments with 40% of charge and also more instants with less than 100% than before.

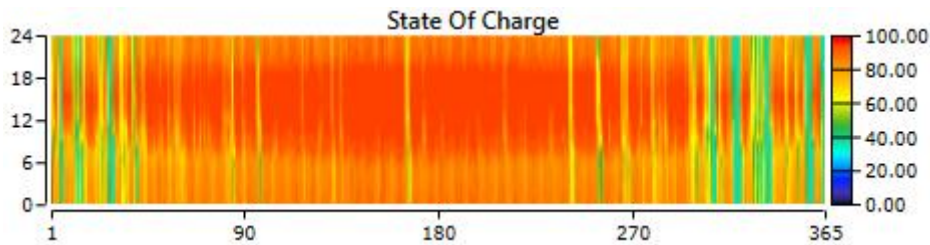

Figure 57: State of charge of the battery in each hour of the year for capacity shortage 3%

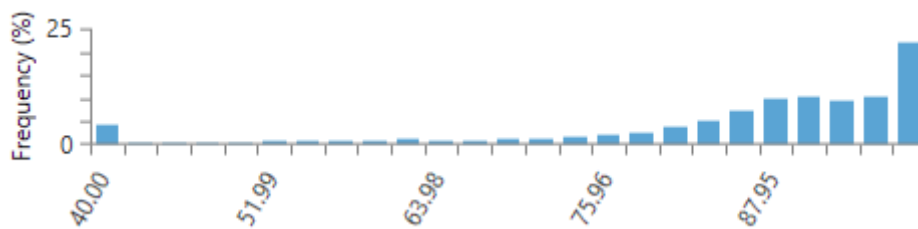

Figure 58: Frequency of each state of charge during the year for capacity shortage 3%

In Figure 59 is the PV power output, which as is expected is lower than in the previous solution.

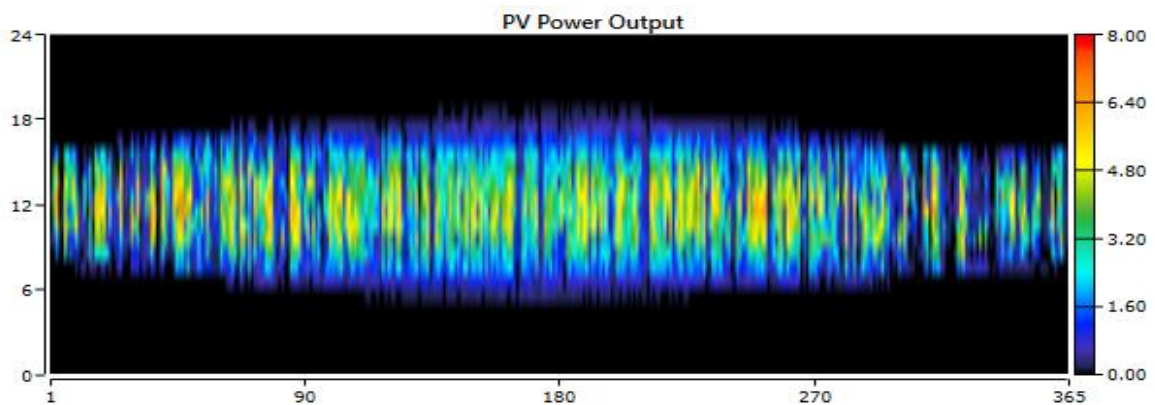

Figure 59: PV power output during the year for capacity shortage 3%

Figure 60 shows the inverter output, now we can see that we have more zeros in the winter months.

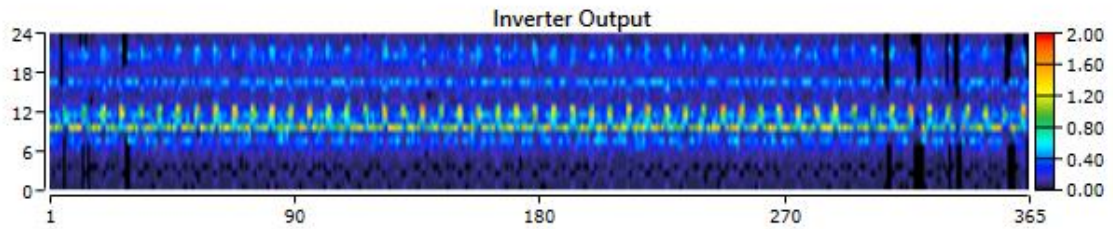

Figure 60: Inverter output during the year for capacity shortage 3%

5.5. Optimal solution for a 4% of capacity shortage

In the optimal solution given for a 4% of capacity shortage the PV power has been highly reduced, but the number of batteries has increased. The inverter power has also grown a little bit. This affects to the cost of each the components as we see in Figure 61. Now we have a lower cost for the PV plat respect the previous solution, but higher cost of batteries.

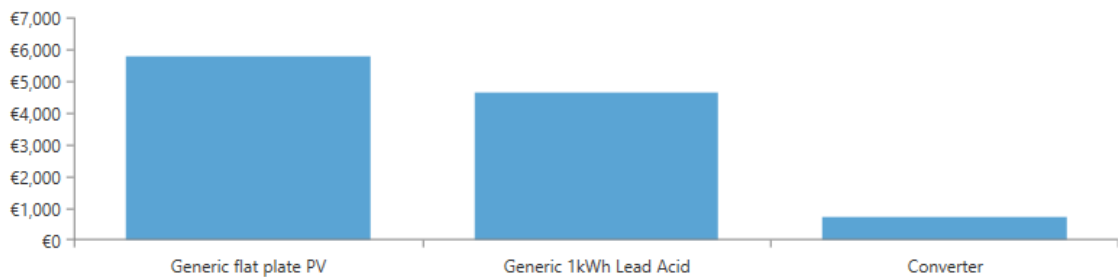

Figure 61: Cost of each component for capacity shortage 4%

In Figure 62 we have the cash flow by type of costs. We see there that the cost have decreased while the shortage increases.

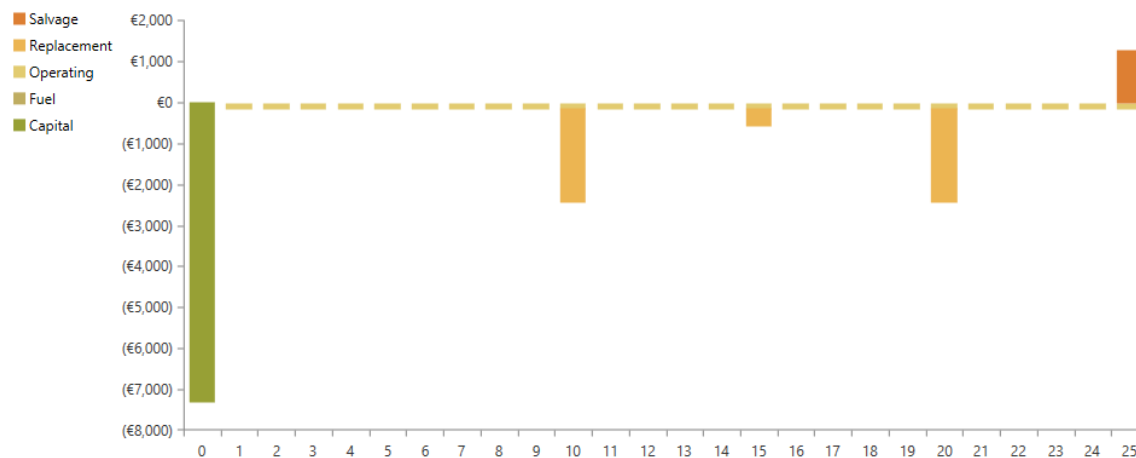

Figure 62: Cash flow divided in different costs for capacity shortage 4%

In Figure 63 we see this solution's cash flow separated by each component. We appreciate in the initial cost that the highest part comes from the PV modules and the second from the batteries, but the differences between them are smaller than in the previous solution.

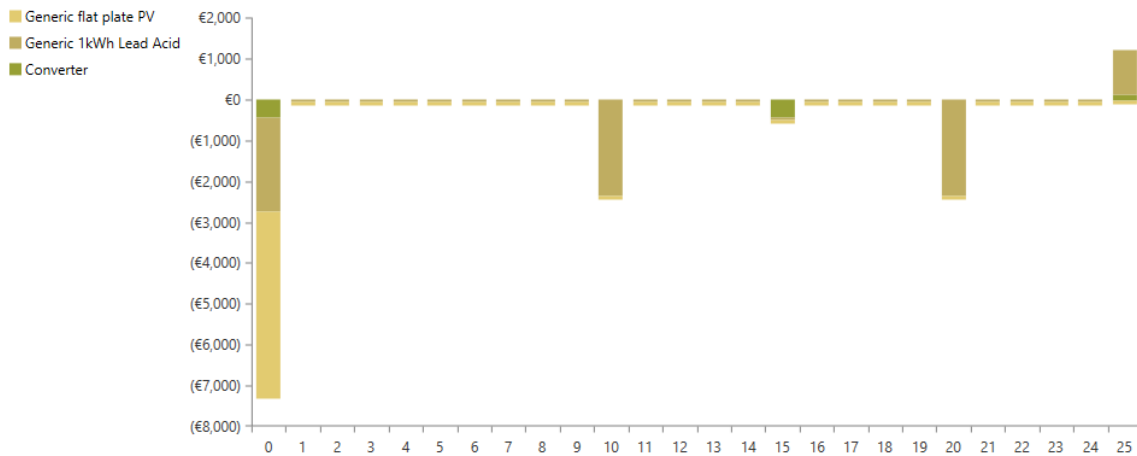

Figure 63: Cash flow divided by the component for capacity shortage 4%

We can appreciate in Figure 64 that the monthly average electricity production has been pretty reduced respect the preceding solution.

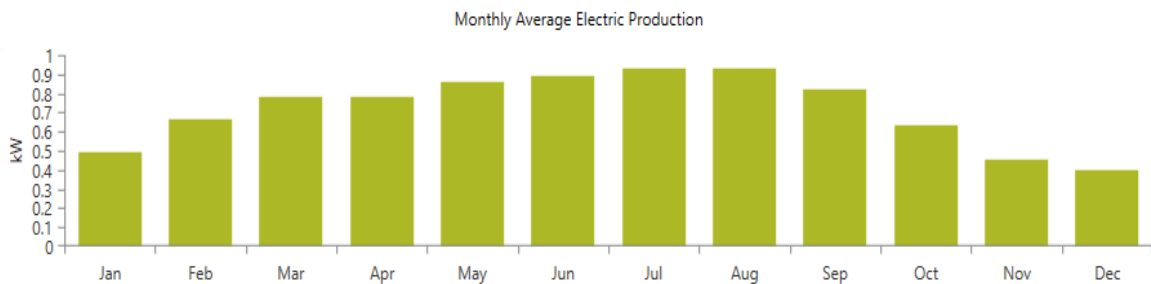

Figure 64: Monthly average electric production for capacity shortage 4%

As in the other solution the quotient shown in Figure 65 is the same.

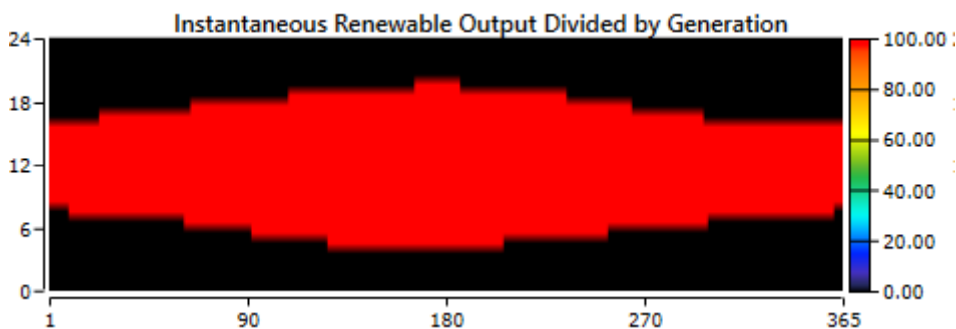

Figure 65: Instantaneous renewable output divided by generation for capacity shortage 4%

In reference to the state of the battery, we appreciate in Figures 66 and 67 that we have a 100% of charge of the batteries in less than the 25% of time in a year. Also, we have a 40% of charge during the 5% part of the year.

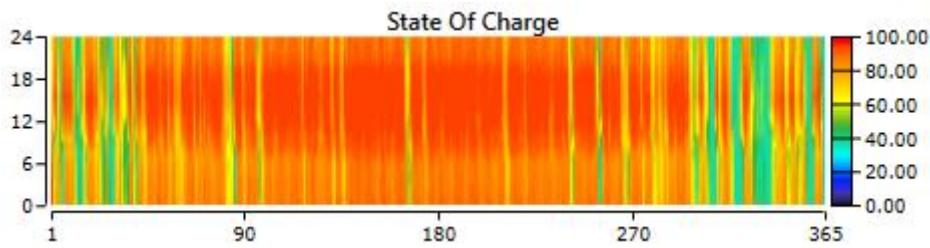

Figure 66: State of charge of the battery in each hour of the year for capacity shortage 4%

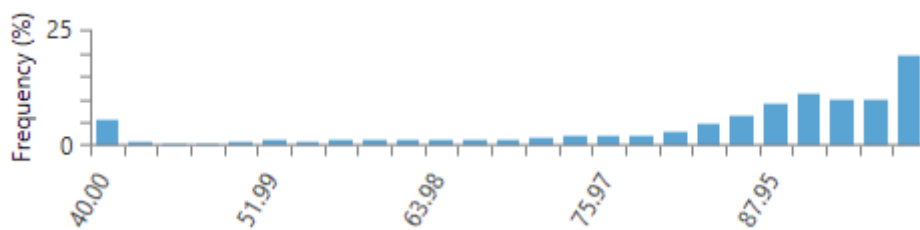

Figure 67: Frequency of each state of charge during the year for capacity shortage 4%

In Figure 68 we appreciate that the PV power output values are pretty lower than before, because of the reduction of installed PV power, being the maximum reached less than 6 kW.

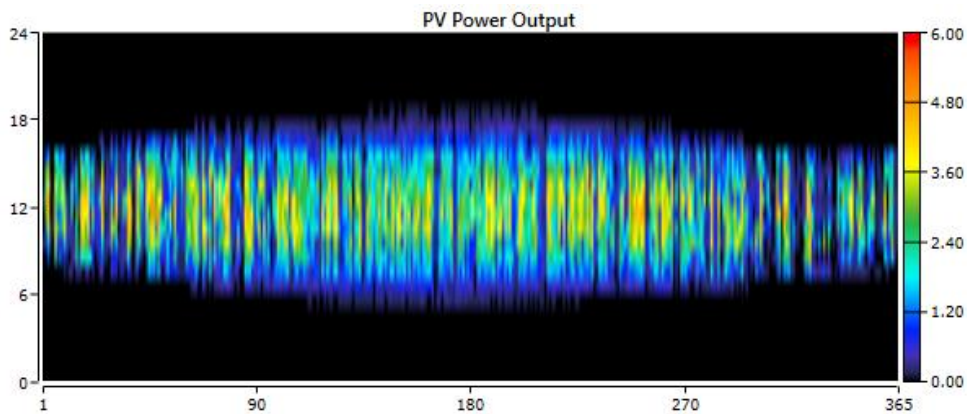

Figure 68: PV power output during the year for capacity shortage 4%

The behavior of the inverter output (Figure 69) remains the same as before, but we have more zeros than before.

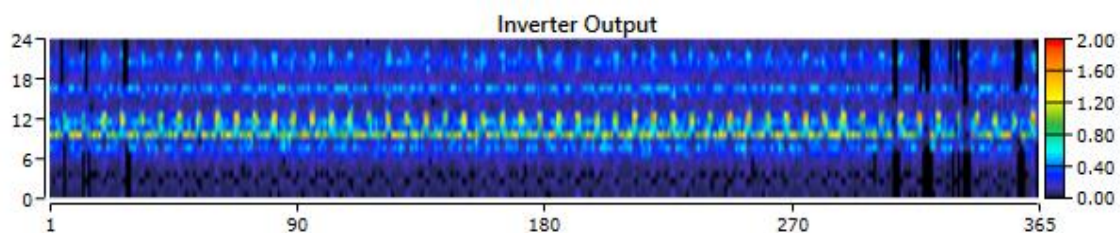

Figure 69: Inverter output during the year for capacity shortage 4%

5.6. Optimal solution for a 5% of capacity shortage

In this solution the value of the PV power has been increased a little bit respect the anterior solution, and the number of batteries has been pretty reduced. The converter power has been reduced also. Consequently, as we appreciate in Figure 70 the cost of the converter and the batteries has decreased respect the anterior solution and the cost of the PV plat has grown.

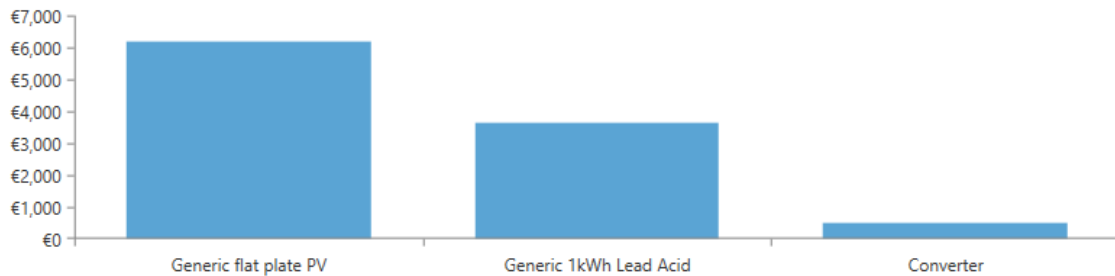

Figure 70: Cost of each component for capacity shortage 5%

In Figures 71 and 72 we have the cash flow for this solution, by type of cost and by components respectively. In Figure 70, we see all costs have been reduced, having a great difference respect the first solution shown for a capacity shortage of 0%, overall in the case of the capital cost.

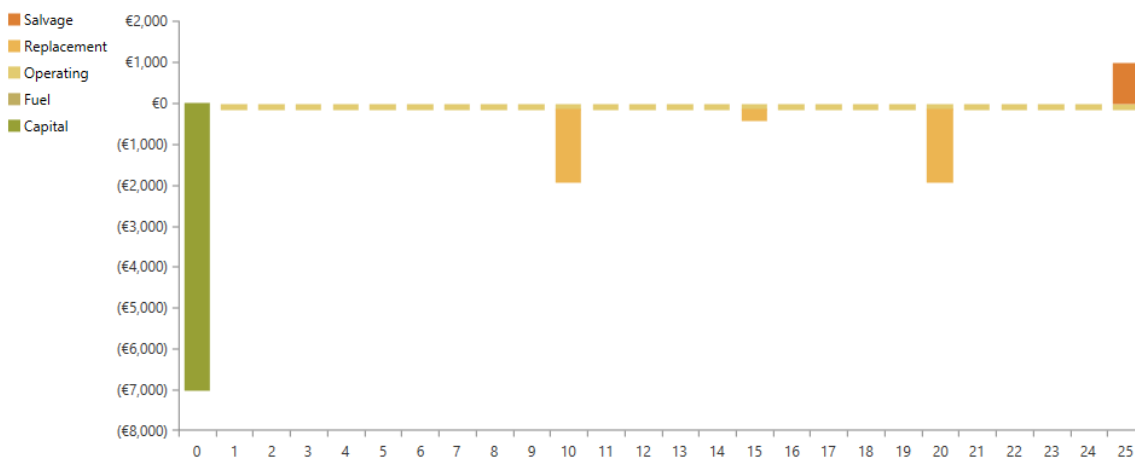

Figure 71: Cash flow divided in different costs for capacity shortage 5%

In Figure 71 we appreciate another time the result of the increase of the PV power and the reduction of the other components respect the previous solution. Also, we realize about the huge difference between the capital cost in this solution and the one showed for the capacity shortage of 0%.

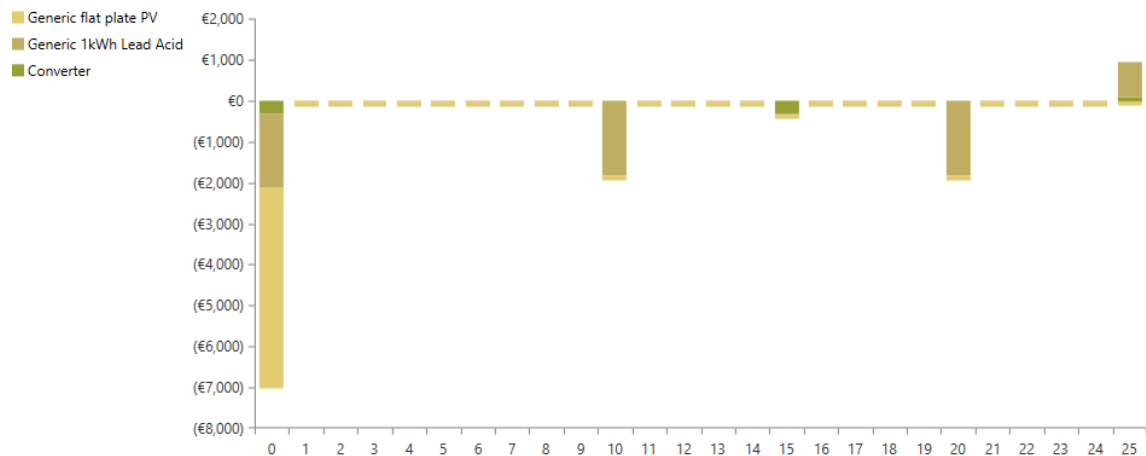

Figure 72: Cash flow divided by the component for capacity shortage 5%

Here we see the monthly average PV electricity production, which is higher than in the preceding solution, but is pretty lower than in the first one.

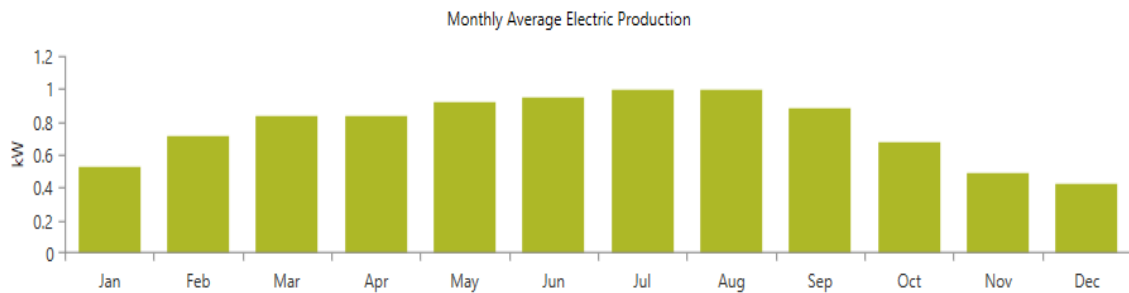

Figure 73: Monthly average electric production for capacity shortage 5%

The instantaneous renewable output divided by generation (Figure 74) stays the same than in the other solutions.

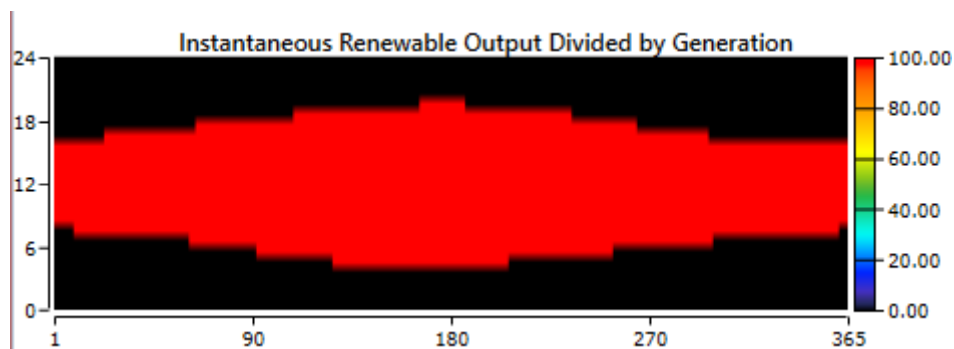

Figure 74: Instantaneous renewable output divided by generation for capacity shortage 5%

The state of charge is shown in Figures 75 and 76. We see that the 100% of charge of the batteries is accomplished less than in 25% of hours of the year. Also, we have 40% of charge in more than the 5% of hours of the year. Also the frequency of hours with a percentage of charge between 80% and 40% is pretty high.

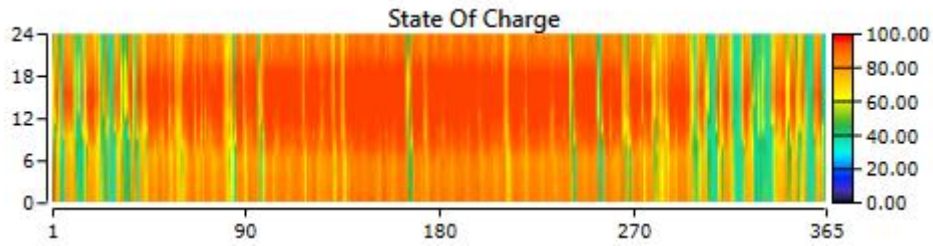

Figure 75: State of charge of the battery in each hour of the year for capacity shortage 5%

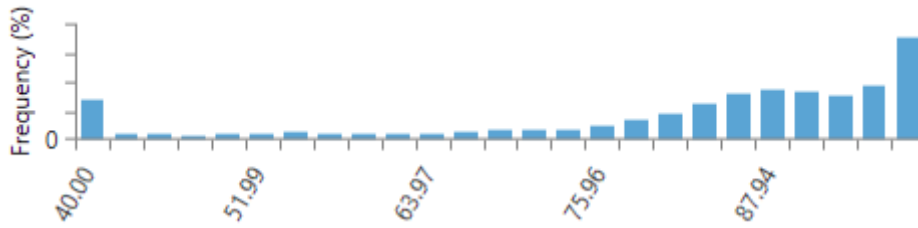

Figure 76: Frequency of each state of charge during the year for capacity shortage 5%

The output PV power (Figure 77) values are almost the same than in the previous solution, but a little bit higher.

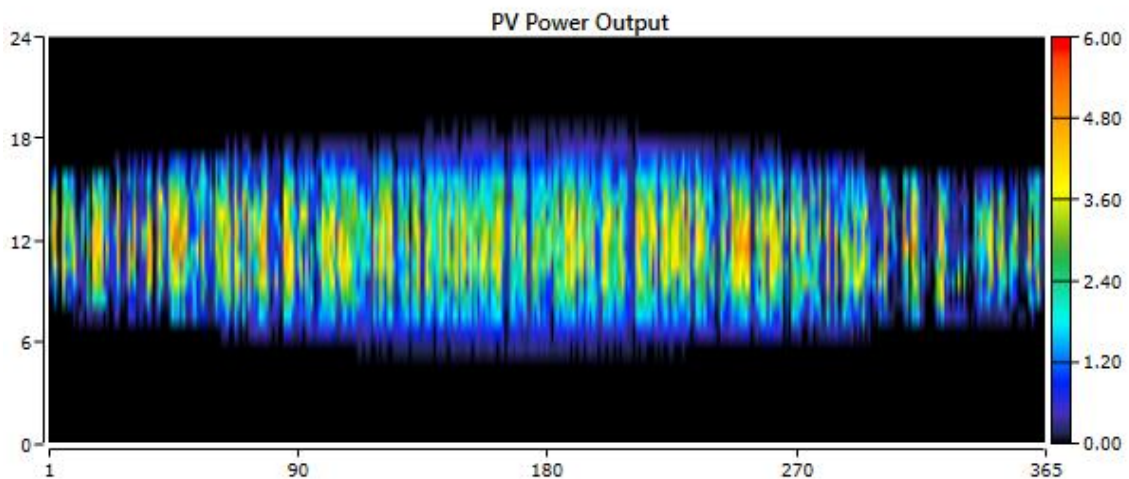

Figure 77: PV power output during the year for capacity shortage 5%

Finally, we have the inverter output of this solution, which is almost the same than before, but as expected with more instants with zeros.

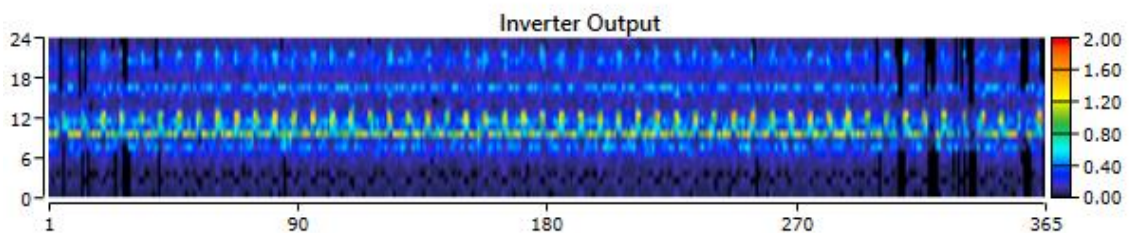

Figure 78: Inverter output during the year for capacity shortage 5%

6. CONCLUSION

On balance, we have realized that we can reduce highly the cost of our installation if we try to optimize it as much as possible. Also, we have focused on how the modification of the value of the capacity shortage can change higher the cost of our system.

The elements which are part of a PV system have a high price, overall the batteries and the PV modules. Consequently, a little modification in the installed power or in the quantity of them can be pretty high. Because of that, it is really important to optimize the installation to adequate it to our real necessities and not installing an excess of power, which can suppose an important increase in the total cost of the system.

The principal aspect we have analyzed is the effects of the variation of the capacity shortage value. The capacity shortage is the percentage of times when we have lacks of energy during the whole year.

As we have analyzed before, the capacity shortage has a big effect over the costs of the installation. On one hand, with a value of 0% of capacity shortage our installation costs would be: 0.561 € of COE, 18,455 € of NPC, 513.55 of Operating Cost and 11,816 € of Initial Capital. This supposes that the total cost of the system is about 30,785 €. But, on the other hand, with a capacity shortage of 5% our costs would be: 0.327 € of COE, 10,319 € of NPC, 255.21 € of Operating cost and 7,020 € of Initial capital, being a total cost around 17,595 €. We can see that the difference is huge, because with a capacity shortage of 5% we can save around 13,190 €.

Although, we cannot forget that the capacity shortage supposes that in several moments of the year we are not going to have enough energy for our energy necessities. If we set a high value of capacity shortage we will have a lot of moments with lacks of energy over the year. Whereas if we choose a low value of capacity shortage, for example 5%, this moments will be less frequent and we will save a lot of money.

Consequently, we have to balance between having less lacks of energy during the year and save as money as possible. In summary, we have to choose the optimized configuration for our requirements.

ABSTRACT

The object of this project is to optimize a PV power system for a domestic application by using the software HOMER. First, we have analyzed the different types of PV systems in reference to the relationship with the grid. Then, we have chosen the most suitable option for our application. In our case, the choice has been an off-grid system.

The off-grid PV system has been developed with the software HOMER. This software requires you to add the loads, components and resources which take part in the system you want to design. For the loads you can introduce your consumption measured data or model it with HOMER. The software can also model the loads by using its database and give the typical values of consumption for each month or type of building and also simulate the typical variations of consumption in a day. For the components, HOMER has a big list of components, since generators of all kinds, to storage systems and some types of electronic components. For the components you have to introduce the cost of each one and after you can fix the quantity or select the option of HOMER optimization which gives you the best option. Then you have to introduce the resources. It allows you to introduce your own data or use its database. HOMER has a tool which lets you to get the data of temperature, wind and sun of your installation only by introducing your location.

Once we have designed our system, HOMER allows you to simulate the installation and with its database and its algorithms gives you the optimized solution. This solution is the cheapest possible configuration of components which allows you to accomplish the required necessities of the system.

In our simulation we have analyzed also the influence of the capacity shortage in our system. The capacity shortage is measured in a percentage respect the whole year and it represents the moments when the installation does not satisfy the energy requirements of the loads. We have seen that as high is the value of the capacity shortage less is the cost of the installation. So for designing the installation we have to choose or accomplish the requirements of the load in all instants of the year or not satisfy the energy necessities of in a few moments and save a big quantity of money.

Key words:

PV off-grid system, HOMER, simulation software, optimized solution, capacity shortage.



FERIT
FAKULTET ELEKTROTEHNIKE, RAČUNARSTVA
I INFORMACIJSKIH TEHNOLOGIJA OSIJEK

REFERENCES

- [1] REN21 Secretariat. (2017). *REN21. 2017. Renewables 2017 Global Status Report*. Paris.
- [2] European Commission. (n.d.). *2020 Energy Strategy*. Retrieved from <https://ec.europa.eu/energy/en/topics/energy-strategy-and-energy-union/2020-energy-strategy>
- [3] European commission. (n.d.). *2030 Energy Strategy*. Retrieved from <https://ec.europa.eu/energy/en/topics/energy-strategy-and-energy-union/2030-energy-strategy>
- [4] European Commission. (n.d.). *2050 Energy Strategy*. Retrieved from <https://ec.europa.eu/energy/en/topics/energy-strategy-and-energy-union/2050-energy-strategy>
- [5] Kumar, S., Taneja, L., & Kaur, R. (2015). Design and control of residential off-grid connected PV systems. *2015 International Conference on Recent Developments in Control, Automation and Power Engineering (RDCAPE)* , 204-208.
- [6] Khatami, M., Mortazavi, H., & Mashhadi, M. R. (2013). Designing an off-grid PV system: For a residential consumer in Mashhad-Iran. *AFRICON, 2013* , 1-5.
- [7] Putra, A. W., Kamandika, E., & Rosyadi, S. (2016). Study and design of hybrid off-grid PV-generator power system for administration load and communal load at three regions in Indonesia. *Power Engineering and Renewable Energy (ICPERE), 2016 3rd Conference* , 57-62.
- [8] Al-Addous, M., Dalala, Z., Class, C. B., Alawneh, F., & Al-Taani, H. (2017). Performance analysis of off-grid PV systems in the Jordan Valley. *Renewable Energy* , 930-941.
- [9] Mandelli, S., Brivio, C., Colombo, E., & Merlo, M. (2016). Effect of load profile uncertainty on the optimum sizing of off-grid PV systems for rural electrification. *Sustainable Energy Technologies and Assessments* , 34-47.
- [10] Eteiba, M., Barakat, S., Samy, M., & Wahbaa, W. I. (2018). Optimization of an Off-Grid PV/Biomass Hybrid System with Different Battery Technologies. *Sustainable Cities and Society* .
- [11] Azuara Grande, L. S., Yahyaoui, I., & Gómez, S. A. (2018). Energetic, economic and environmental viability of off-grid PV-BESS for charging electric vehicles: Case study of Spain. *Sustainable Cities and Society* , 519-529.
- [12] Madeti, S. R., & Singh, S. (2017). Online modular level fault detection algorithm for grid-tied and off-grid PV systems. *Solar Energy* , 349-364.



[13] Veldhuis, A., & Reinders, A. (2015). Reviewing the potential and cost-effectiveness of off-grid PV systems in Indonesia on a provincial level. *Renewable and Sustainable Energy Reviews* , 757-769.

[14] Jäger-Waldau, A. (2017). *PV Status Report 2017*. Luxembourg: Publications Office of the European Union.

[15] Jäger-Waldau, A. (2014). *PV Status Report 2014*. Luxembourg: Publications Office of the European Union.

[16] *SolarShop*. (n.d.). Retrieved from <http://www.solarno.hr/katalog/proizvod/0084/akumulator-solarni-sole-85-ah>

[17] *HOMER Energy*. *Total Net Present Cost*. (n.d.). Retrieved from https://www.homerenergy.com/support/docs/3.9/total_net_present_cost.html

[18] *HOMER Energy*. *Initial Capital Cost*. (n.d.). Retrieved from https://www.homerenergy.com/support/docs/3.9/initial_capital_cost.html

[19] *HOMER Energy*. *Levelized cost of energy*. (n.d.). Retrieved from https://www.homerenergy.com/support/docs/3.11/levelized_cost_of_energy.html

[20] *HOMER Energy*. *Operating cost*. (n.d.). Retrieved from https://www.homerenergy.com/support/docs/3.11/operating_cost.html