

**Investigation of Unusual Mineral Occurrences in Southern Ohio and Their Possible
Relation to the Mineralization of Serpent Mound**

A Senior Honors Thesis

Presented in Partial Fulfillment of the Requirements for the degree of
Bachelor of Science with distinction in Geological Sciences
At The Ohio State University

By

Stuart B. Wells

The Ohio State University
December 2003.



Project Advisor:

Dr. Hallan C. Noltimier

Department of Geological Sciences

CONTENTS

TITLE PAGE.....	1
CONTENTS	2
ACKNOWLEDGEMENTS:.....	3
FIGURES	4
ABSTRACT	5
INTRODUCTION AND OBJECTIVES.....	6
HISTORICAL BACKGROUND.....	6
REGIONAL SETTING.....	7
PREVIOUS INVESTIGATIONS.....	9
THE CARLISLE MINE	10
GOLD PROSPECTING	11
FIELD PROCEDURES	12
BEDROCK GEOLOGY - SILURIAN.....	13
BEDROCK GEOLOGY - DEVONIAN.....	15
THE UNCONFORMITY, KARST, AND THE ENIGMATIC 'WHITE LAYER'	16
GLACIAL GEOLOGY.....	18
BEDROCK MINERALIZATION	18
STREAM DEBRIS	20
BEDROCK FEATURES - KARST DEVELOPMENT.....	23
BEDROCK FEATURES - FAULTING	23
SERPENT MOUND - STRUCTURE	25
SERPENT MOUND - MINERALIZATION	26
SERPENT MOUND - ORIGIN	26
CONCLUSIONS	27
SUGGESTED RESEARCH.....	28
REFERENCES:.....	29
APPENDIX 1- STRATIGRAPHIC COLUMN.....	30
APPENDIX 2- BEDROCK GEOLOGY MAP	33
APPENDIX 3- GLACIAL GEOLOGY MAP.....	34
DESCRIPTION OF MAP UNITS.....	35
APPENDIX 4- SEM DATA	36

ACKNOWLEDGEMENTS:

This work was completed with the assistance of many people over the course of three years, and I sincerely thank everyone who played a part.

I would first like to thank my advisor, Dr. Hallan Noltmier, for giving me the opportunity to start this project and for providing the encouragement, insight, and guidance which made it possible to finish.

I thank Robert Glotzhofer and Debbi Huff of the Ohio Historical Society for taking the time to help me track down some of my elusive historical references.

I gratefully thank the Friends of Orton Hall Fund for their financial support and for their continued support of student research here. With this I was able to use the scanning electron microscope which was a wonderful experience. I would also like to thank Satish Alapati who actually helped me to use the SEM and analyze data.

I thank the Orton Memorial Library staff for their assistance and for reshelving the 100+ books, journals, and maps I checked out throughout the course of this project.

In addition, I would like to thank Dr. Doug Pride and Dr. Gerald Newsom for taking time out of their schedules to serve on the honors examination committee. It is greatly appreciated.

For their help from beginning to end, I wish to thank Bill Hallam, Ed Reeves, and Gary Doles. For all of your help, donating samples, taking me to see local geology sites, introducing me to others, and for spending much of your time and money, I am incredibly grateful. Special thanks go to Bill Hallam for first inviting me to work on this project and for giving me a place to stay while I did my field work.

FIGURES

Figure 1. (p. 8)

A. Map of southwestern Ohio. Arrows point to the study area (top) and Serpent Mound.

Figure 2. (p. 10)

A. Bill Hallam standing in the vertical shaft of the Carlisle Mine facing the side tunnel.

B. Mine diagram, from above and facing east.

Figure 3. (p. 14)

A. Cross section of 'pseudo-algal' structures in the Greenfield Dolomite, Old Rucker Quarries (Wells, 1942).

B. Pseudoalgal structures in the Greenfield Dolomite at the Carlisle Mine.

Figure 4. (p. 17)

White crumbly layer at unconformity surface, Carlisle Mine.

Figure 5. (p. 20)

Dendritic pyrolusite and iron staining in the Greenfield Dolomite, Carlisle Mine.

Figure 6. (p. 21)

Selected Images and Elemental Spectra from the Scanning Electron Microscope.

Figure 7. (p. 22)

A. Gold flakes panned from Buckskin Creek

B. Electron micrograph of gold flake from Buckskin Creek. Scratches on surface believed to be evidence of glacial transport.

Figure 8. (p. 24-5)

A. Aerial Photograph of the lineation running NNW through the center.

B. Four people standing in the groove in the field near Humboldt, Ohio. From left: A neighbor, Steve Hallam, Bill Hallam, and myself. The view is East.

ABSTRACT

This project focuses on a mine prospect site I recently located in Ross County, Ohio, dating back to the 1930's, which is an area of unusual and heretofore undocumented mineralization. Limestone concretions and samples of crystalline quartz and pyrite occur in sizes and quantities which are quite uncommon in the state of Ohio.

The goals of the project were, through field observation and laboratory analysis, to identify the nature and extent of mineralization in the study area, find its relation to other mineral localities in south-central Ohio, and determine what role unrecognized faults and/or hydrothermal activity in the area have played in the genesis of the unusual mineralization.

The area lies along the unconformable contact between upper Silurian and middle Devonian bedrock, and also includes ground and end moraines from both the Wisconsinian and Illinoian glaciations. Sulfide mineralization in the middle Devonian Ohio Shale occurs as nodules of pyrite and marcasite, with trace barite, up to ten centimeters in diameter embedded in black shale. This unit has also yielded crystalline quartz lining contorted cavities in large limestone concretions up to one meter across. Traces of barite, marcasite, pyrite, galena, and glacial gold have been found in stream sediments throughout the area.

Aerial photographs, verified in the field, show a lineation extending northward through the study area in Ross County, which may be related to radiating faults from the Serpent Mound Disturbance in Adams County, 30km to the south.

INTRODUCTION AND OBJECTIVES

The objectives of this project are to document the history and geology of a number of unusual geological features in Ross County, Ohio and to propose evidence in support of or against a structural or mineralogical relationship with the Serpent Mound disturbance. The objectives were pursued through academic research of previous and related studies and field investigation of bedrock and glacial geology, as well as local mineralization. For the purposes of this project, the region of focus will be referred to as the study area and is defined as the south half of the South Salem 7 ½ minute USGS topographic quadrangle, specifically along Buckskin and Cliff Run Creeks.

HISTORICAL BACKGROUND

The project focuses on a historically and geologically fascinating site near the town of Humboldt in Ross County, Ohio. Several minerals, not commonly found in Ohio, are present near a small mine prospect, dug in the 1930's and rediscovered by three local residents in 1997. While investigating a rumor about a gold mine in the area, three part time prospectors from Ross County uncovered two articles, one from a newspaper and another from a local history book, which mentioned it. The articles tell the following story:

A farmer named T.E. Carlisle had discovered flakes of gold in a stream on his property. He was familiar with stories of the California gold rush and geology associated with gold deposits and began to search for a source for the gold in the area. Upon discovering a white layer in the bedrock on his property, and knowing the association of quartz and gold, he believed he had found a gold-laden vein and sent a sample to the 'state geologist' in Columbus for analysis.

The newspaper article says that, "...samples taken from the Carlisle farm and sent to Howard R. Goodwin, curator of mineralogy at the Ohio State Museum, were pronounced gold." (Greenfield Republican, 1933). The article from Hometown Chronicles, a local historical collection (Harris, 1955), says that Carlisle and his son sunk several shafts, one of which, "...was driven down thirty-two feet with a lateral tunnel extending off for some distance." The mine location studied is almost certainly the same prospect (described in more detail later in this report) and is therefore referred to in this paper as *the Carlisle Mine*.

I was unsure if the geologist referred to in the articles was a geologist from the Ohio State (University) Museum or a State Museum of Ohio. Through personal communication, first with Dale Gnidovec, curator of the Orton Geological Museum at Ohio State, then Robert Glotzhober, curator of Natural History at the Ohio Historical Society, and also Steve Goodwin, recently retired from the Ohio Department of Natural Resources and a grandson of Howard R. Goodwin, I was able to discover that Mr. H. R. Goodwin was, in fact, the Registrar, Staff Artist, and Curator of Archaeology at the Ohio Historical Society from 1923 to 1939.

REGIONAL SETTING

The study area is located in southwestern Ohio at the southwest end of Ross County. A significant coincidence of bedrock, glacial, structural, and topographic phenomena exists in this area. It lies at the common geographic boundary of the northwest edge of the Appalachian topographic zone, the eastern end of the Interior Low Plateau Province, and along the southeast termination of Pleistocene glaciation. Three Paleozoic periods are represented in the bedrock, Silurian, Devonian, and Mississippian, with a 40 million year

exposed above the unconformity is the concretion-bearing Huron Member of the Ohio Shale. Finally, a Precambrian basement fault originates in Kentucky and passes directly below the Serpent Mound disturbance south of the study area before continuing northward.

PREVIOUS INVESTIGATIONS

Only research on the surficial glaciation of the area and a few descriptions of local bedrock features have been previously reported. Pleistocene glacial deposits were mapped and described by Michael J. Quinn for a 1974 Ph.D. dissertation and subsequently published as an Ohio Geological Survey Report of Investigations (Quinn and Goldthwait, 1985). Charles Napper described limestone concretionary forms and mineralization in the Rucker Quarries of Greenfield (Napper, 1917) and claimed to have found a sphalerite specimen weighing 30 pounds.

One of the most extensive descriptions of mineralization throughout the state is contained in the book, Minerals of Ohio, by Ernest H. Carlson (Carlson, 1991). Pages utilized for this project included descriptions of characteristics and extent of the Serpent Mound zinc district, pyrite and carbonate concretions in the basal Ohio shale at Copperas Mt.- about 10 miles southeast of the Carlisle Mine, and occurrences of sulfide bedrock mineralization and glacial gold occurrences in the area. Michael C. Hansen also mentioned the area in OGS Geofacts #9, *Gold in Ohio* (Hansen, 1995).

THE CARLISLE MINE

The Carlisle Mine (fig. 2), an historic gold prospect and the center of the focus area of this project is located halfway between Greenfield and Bainbridge, and approximately 1.5 miles southwest of the town of Humboldt.

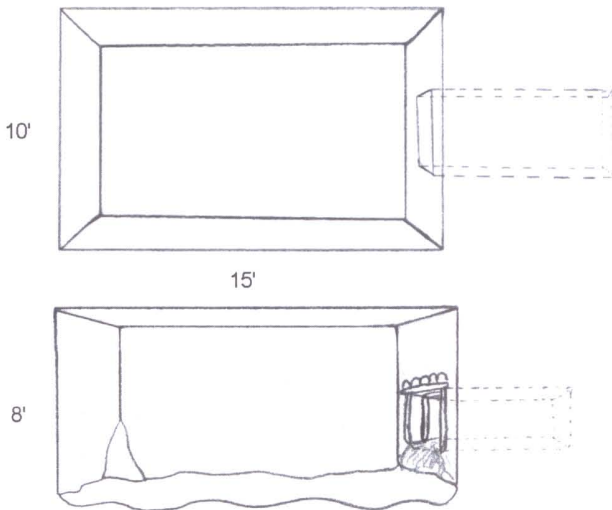

Figure 2.

- A. Bill Hallam standing in the vertical shaft of the Carlisle Mine facing the side tunnel.
- B. Mine diagram, from above and facing east.

The mine prospect has two parts, a rectangular vertical shaft 10' by 15' and approximately 10' deep to the water, and a timbered horizontal tunnel set into the side of the vertical shaft, 5' below the surface which extends 12' feet to the south (fig. 2). It was excavated into and along the local unconformity between late Silurian and middle Devonian bedrock. The lower walls of the shafts are Silurian Greenfield Dolomite. It is a dark gray massive dolomite and at the mine exposure has an undulating top surface with several feet of vertical relief. It displays iron oxide and manganese oxide staining (fig. 5) and 'pseudo-algal structures' (Wells, 1942). These are patterns in the rock with a swirled and layered appearance which may be algal structures similar to stromatolites or soft-sediment deformation features. (fig. 3a) They correspond with nearly identical structures reported in Greenfield's Rucker Quarry, near the top of its 53' type section of the Greenfield Dolomite (Wells, 1942) (fig. 3b).

GOLD PROSPECTING

The earliest references to gold in Ross County date back to 1901. Residents and hobbyist prospectors have panned gold flakes and small nuggets from streams and tributaries in this area for many years (fig. 7). The Carlisle Mine was originally excavated in 1933 when a farmer and his son uncovered what they believed to be a mineral vein in a hill behind their farm. Having found placer gold in their stream and knowing that gold was associated with quartz veins, they believed that a soft whitish layer they found in a small ravine on their property was 'crumbly quartz'. Believing it to be the source of the gold, they reportedly dug a shaft twenty-two feet down and then a tunnel extending horizontally underneath the hill. According to one local legend, they discussed their project with a man who would finance

additional digging, equipment purchases, and machinery for extraction, but when he learned that they expected to find tens of thousands of dollars in gold, he had a heart attack and died.

Current understanding is that the gold found in Paint Creek Valley is derived from glacial material and not from the actual bedrock (Smith, 1992). However, as the mine lay in an area where unusual minerals were present, a closer, more analytical look into the legendary "vein" seemed appropriate.

In August of 2003, three part-time prospectors who brought the mine and minerals to my attention in the first place, cleared the area around the mine shaft with a backhoe and pumped out the water which covered the entrance. Bill Hallam, a co-discoverer of the mine, and I then climbed down a ladder to take a closer look at the entrance and the bedrock inside the opening (fig. 2). The ceiling in the entrance of the side tunnel was shored up with split timbers which are surprisingly intact. Only the first six feet is timbered, where softer material forms the ceiling. After that, the walls and ceiling are dolomite and much more solid. The composition of the floor could not be determined because water, mud, and debris still filled the hole to a waist deep level.

There have been several unconfirmed local reports that gold can be found in the smaller streams and creeks in southeastern Ohio. Because they do not drain glaciated areas, re-weathering of fluvial placer deposits in late Paleozoic rocks may explain these occurrences. Further investigation would be warranted if these reports were confirmed.

FIELD PROCEDURES

I measured a stratigraphic column along a small stream, beginning at the Carlisle Mine and continuing upstream to the east until no further bedrock was exposed (Appendix 1). The thickness measured was 120' and was mostly through the Devonian Ohio Shale Formation.

The base of the column was in the Silurian Greenfield Dolomite, in which the mine is constructed, with the white layer just above that. Then, the bedrock was covered for several tens of feet until the Ohio Shale appeared and could be seen with little difficulty for the rest of the traverse up the stream bed.

BEDROCK GEOLOGY - SILURIAN

The oldest bedrock is the fine-grained, tan, late Silurian Greenfield Dolomite. It is known for a concretionary layer of pseudo-algal features (fig. 3) near the top of the section, and for large localized disturbances in the bedding planes lower down. The bedding is in two to six inch layers with carbonaceous partings and occasional massive ledges. It is exposed in the study area only in the bottom of the Buckskin and Cliff Run Creek Valleys and at the Carlisle Mine (see bedrock geology map, Appendix 2).

The type section of the Greenfield Dolomite is found six miles to the northwest on the east side of the town of that name. Across Paint Creek from Greenfield lies what is now known as the Old Rucker Quarry, which was in operation from 1854 until circa 1920 (Harris, 1954). Its 57-foot section of dolomite was described by Orton (1874), Napper (1917), and Wells (1942), including a concretionary layer six feet below the top of the exposure that resembles an algal or some form of biological structure (fig. 3). These structures were also found in a bedrock core fifteen miles to the southeast (Carman, 1955).

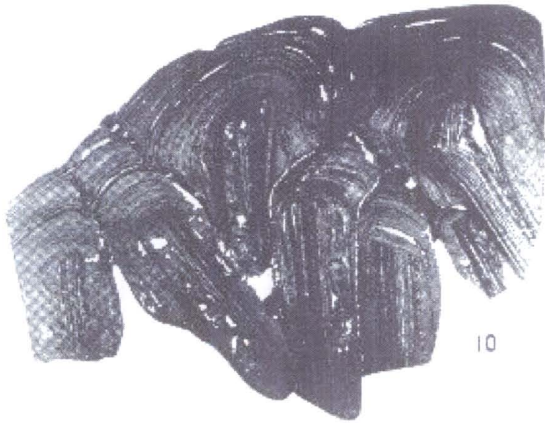

A.

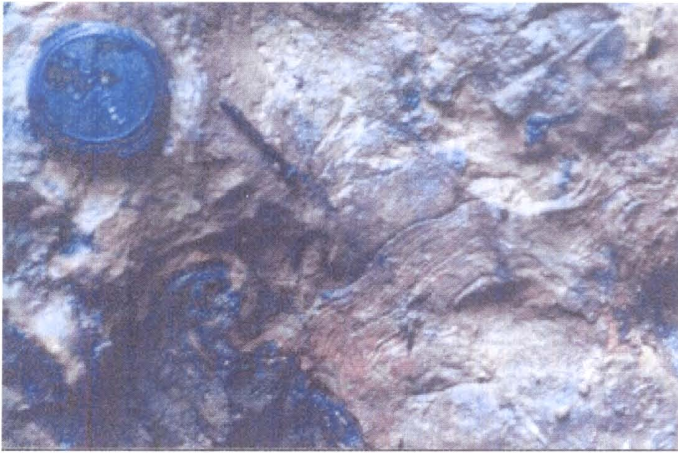

B.

Figure 3.

A. Cross section of 'pseudo-algal' structures in the Greenfield Dolomite, Old Rucker Quarries (Wells 1942).

B. Pseudoalgal structures in the Greenfield Dolomite at the Carlisle Mine (lens cap for scale).

BEDROCK GEOLOGY - DEVONIAN

I measured a stratigraphic section from the mine opening to the highest visible bedrock exposure above the site (Appendix 1). The total vertical distance measured was 120', and the lithology and location of glacial erratics in the stream bed were also recorded and are included on the diagram. The shale is predominantly black and occurs in layers from tiny fractions of an inch to an inch in thickness. Within the shale is a thin layer (18 in.) of tan dolomite which produces a hydrocarbon smell on a fresh surface. Horizons of green, yellow, and gray shale are also found within the section, measure two to five feet in thickness, and are generally discolored by orange staining.

Two large carbonate concretions were found at 62 and 82 feet, measuring three and four feet in diameter, respectively. Given the unmistakable size and appearance of these concretions as well as the location of the Silurian unconformity at the bottom of the section, this portion of the shale is easily identified as the basal Huron Member of the Ohio Shale and correlates well with known occurrences of the unit in the area (Carman, 1947). To the east and north, the Ohio Shale rests upon the Columbus Limestone, but it pinches out to the west until the shale rests directly upon the unconformity surface (Carman, 1955).

In eastern Ross County, the lower unit of the Ohio shale is differentiated as the Olentangy Shale and can be clearly separated by a color change from black to blue. However, due to the continuity of the distinctive concretionary layer, which can be traced across the entire state, and the fact that it is found in the Olentangy Shale to the east, it is believed that the black shale in the western Ross County area is time-equivalent with the Olentangy Shale, and was deposited under more calcium poor conditions and in deeper water, becoming black in color rather than blue (Clifton, 1957).

THE UNCONFORMITY, KARST, AND THE ENIGMATIC 'WHITE LAYER'

Middle Devonian Ohio Shale rests unconformably on the Greenfield Dolomite in western Ross County. There is no known exposure of the contact in the stream beds of my study area. However, by great fortune, the mine was constructed across and along the unconformity, so a cross section is readily visible at that site. The unconformity surface is quite uneven and is marked by a two inch layer of very fine clay.

Unlike the nearly smooth transition from carbonate to shale seen in drill cores in the area, here there was a thick layer of crumbly whitish-tan material composed of clay, chert, and weakly fluorescent minerals (fig.4). This was the 'crumbly quartz' layer, referred to in the book and newspaper articles about the Carlisle Mine (Greenfield Republican, 1933, Harris, 1955). The thickness at the mine location was significant, ranging from six to ten feet with the upper boundary undefined because the bedrock exposure is covered by surface debris for the next thirty vertical feet until the first outcrop of shale above it is reached.

Identification of this layer quickly became an objective for the project. Known by locals and historically as a vein of 'crumbly quartz', it was apparent that it was too soft to be quartz, but seemed at first to be a possible volcanic ash horizon at the unconformity surface. There is a volcanically-derived bentonite layer reported to the west in Indiana within ten feet of the Silurian-Devonian unconformity (Sunderman, 1980). However, due to the excessive thickness of the Carlisle exposure, in contrast to that of most ash horizons, and the lack of characteristic biotite flakes generally found in volcanic ash, this identification was unconvincing.



Figure 4.
White crumbly layer at unconformity surface, Carlisle Mine (hammer for scale).

In the Carlisle Mine, a smooth surface formed by solution is exposed in the northeast corner, showing that the shaft was excavated into a preexisting sinkhole. Some of the karst features of the area are very well developed and were likely created when the former surface was exposed in the Paleozoic, prior to structural subsidence and subsequent deposition of Devonian sediments. A similar 'fossil cave' was exposed in Cincinnati strata near Maysville, KY during excavation of a road cut and was completely full of Tertiary sediments from the time of its formation. The nature of the material found in the walls of the vertical mine shaft and the smoothly contoured appearance of the surface of the dolomite would be adequately explained by the following hypothesis:

Solution features developed in Silurian carbonates while they were exposed at the surface between the Late Silurian and Middle Devonian. Karst sinkhole features were filled with organically rich material derived from the surface before deposition of the overlying strata, one of which later was excavated to become the Carlisle Mine. This also explains why

the white layer is not found at the unconformity surface in other exposures or in any cores taken in the area as one would expect from a volcanic ash horizon.

Elemental Analysis showed the composition of the white layer to be predominantly kaolinite. Chert, recrystallized dolomite, and organic material constituted the remainder of the samples. Under the spectrometer, each sample exhibited an approximately 1:1 Aluminum to Silicon atomic ratio which is consistent with the chemical formula of kaolinite, $\text{Al}_2\text{Si}_2\text{O}_5(\text{OH})_4$ (fig. 6).

GLACIAL GEOLOGY

The Wisconsinan and Illinoian glaciations deposited material in the northwestern two thirds of Ross County. The area within the South Salem USGS topographic map was entirely glaciated. The Wisconsinan advance did not reach the southeast third, which has noticeably larger relief. However, Illinoian ice covered the topography completely, so that till and erratics can be found up to the top of the hills in the area (Quinn, 1985). The Carlisle Mine lies beyond the end of the Wisconsinan glaciation and downstream from a large number of Illinoian igneous and metamorphic erratics (see glacial geology map, Appendix 3). I found no published information on the composition of glacial erratics in Ross County. Boulder information is depicted on the stratigraphic column (Appendix 1).

BEDROCK MINERALIZATION

The basal unit of the Ohio Shale is the Huron Member, best known as the source of large carbonate concretions that can be seen in various places across the state. The Huron Member is approximately 50 feet thick (Clifton, 1957) and extends from Lake Huron to Kentucky. It is visible wherever the Ohio Shale is exposed.

The concretions range in size from one to ten feet, but in this area are generally between three and five feet in diameter. The shape is spherical when small, progressing to a flattened spheroid with increasing size. The concretions are composed of a thick outer carbonate shell with a fine-grained matrix and secondary veins filled by minerals such as calcite, dolomite, barite, pyrite, and quartz. Inside the outer shell is a septarian core comprised of calcite, fluorite, barite, and celestite, and it sometimes contains an organic nucleus such as a fish bone fragment or petrified wood (Clifton, 1957).

A very interesting and well exposed locality for viewing this section up close is Copperas Mountain, about ten miles to the southeast on the south side of Paint Creek. A detailed description of the site and directions to it can be found in Minerals of Ohio (Carlson, 1991). It is known for the excellent exposure of large concretions there and for efflorescences of melanterite, a mineral formerly known as copperas, which was used in historic times as a dye (Carlson, 1991 and Carlson, 2002).

Barite vein material was found in the upper of the two concretions shown in the stratigraphic column (Appendix 1), and the white layer and underlying dolomite in the walls of the vertical shaft at the Carlisle Mine contain manganese and iron oxides (fig. 5).



Figure 5.
Dendritic pyrolusite and iron oxide staining in the Greenfield Dolomite, Carlisle Mine
(hammer for scale).

STREAM DEBRIS

Rock and mineral fragments in local streams are derived from bedrock and glacial sources and contain a remarkable variety of rocks and minerals. Crystalline pebbles, cobbles, and boulders of schist, granite, gneiss, amphibolite, and several other igneous compositions comprise a majority of the material in the stream beds. After careful sorting, minerals such as barite, galena, pyrite, garnet, and gold are separated. Small nodular pyrite is abundant in the sedimentary bedrock-derived material, and occasional horn corals are present.

(Carbon and oxygen always appear, as the samples are coated with carbon before imaging and oxygen is calculated stoichiometrically.)

BARITE- FROM A GEODE IN THE OHIO SHALE

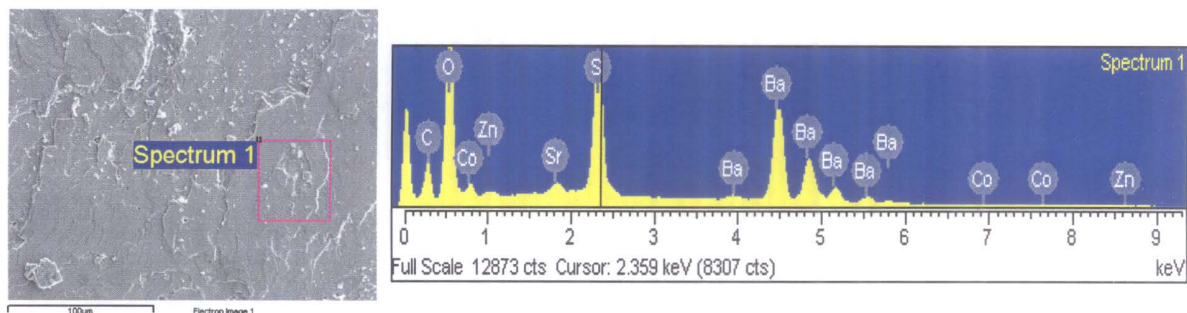

WHITE LAYER MINERALS:

Kaolinite (showing Al, Si, and O peaks)

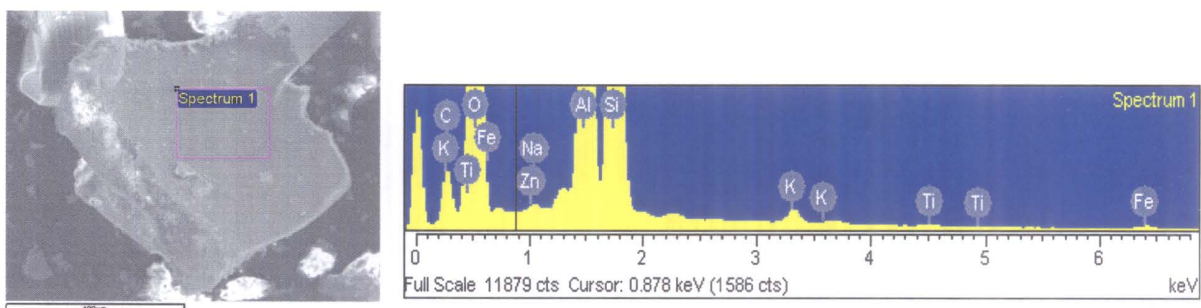

Dolomite (exhibits weak orange fluorescence under short wave ultraviolet)

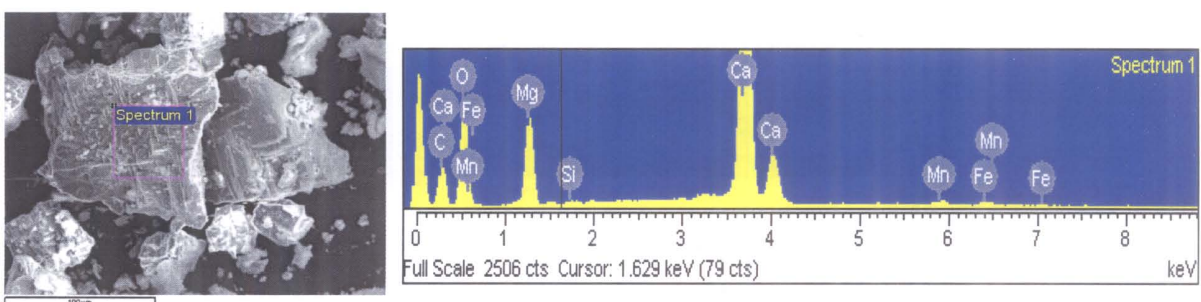

Figure 6.
Selected Images and Elemental Spectra from the Scanning Electron Microscope.
(full data in Appendix 4).

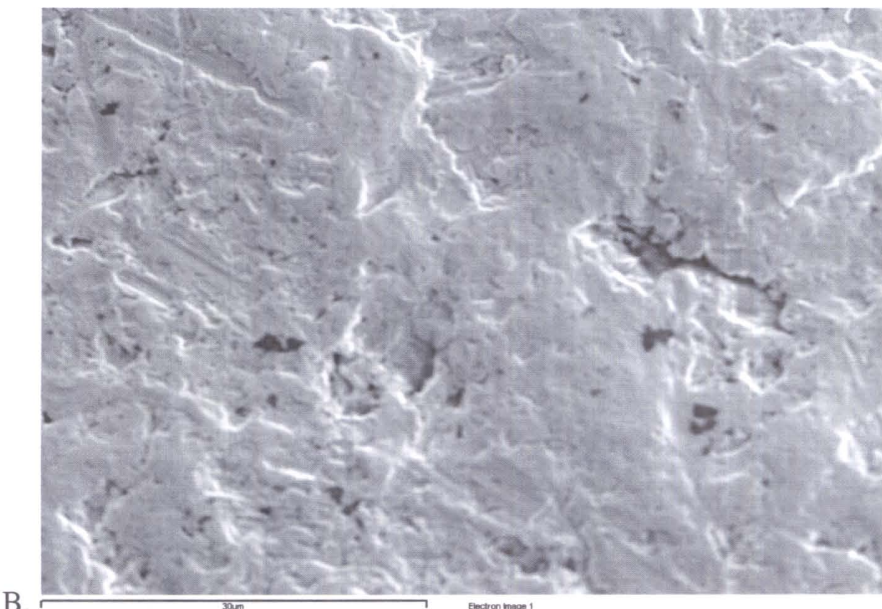
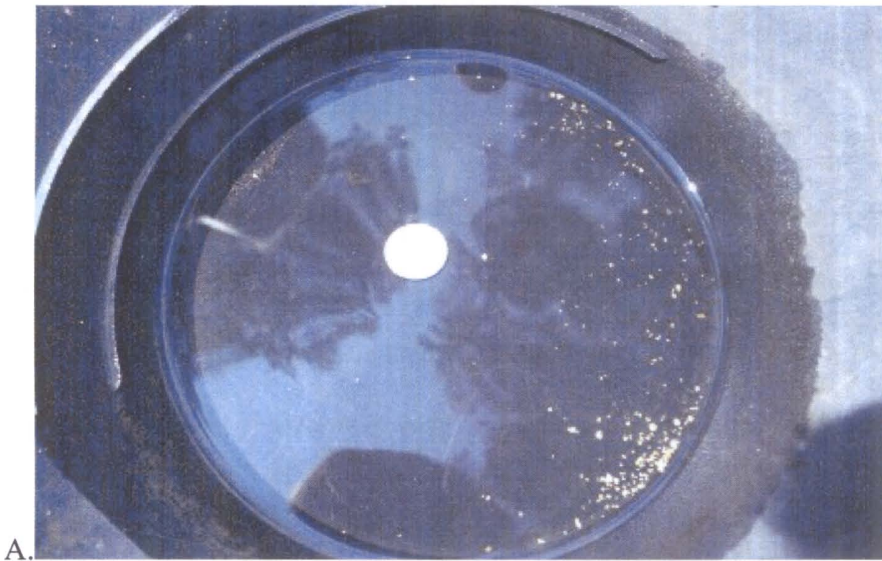

Figure 7.

- A. Gold flakes panned from Buckskin Creek (dime for scale).
- B. Electron micrograph of gold flake from Buckskin Creek. Scratches on surface believed to be evidence of glacial transport.

BEDROCK FEATURES - KARST DEVELOPMENT

I believe that the solution features visible in the Carlisle Mine are paleokarst, rather than recent in age. They were formed prior to deposition of the overlying bedrock, evidenced by the paleosol material completely filling the cavity. There are many caves in the area including a local tourist attraction called Seven Caves. There, underground solution tunnels in the Silurian dolomite collapsed, creating gullies with vertical walls fifty feet in height. It appears that these features are very old in origin as indicated by the advanced stages of cave breakdown which they all exhibit.

BEDROCK FEATURES - FAULTING

Although no geophysical research has yet been done on the bedrock structure, aerial photographs of the study area display a lineation parallel to regional structural trends and known faulting in neighboring Highland County (Tobin, 1961). The lineation follows two gullies with a flat field in between. I took a hike to see if the lineation was expressed on the ground, and when I approached the location, there was a distinct surface groove trending northwest across the field (fig. 8). It was a definite shallow depression six feet in width and 18-24 inches deep.

A.

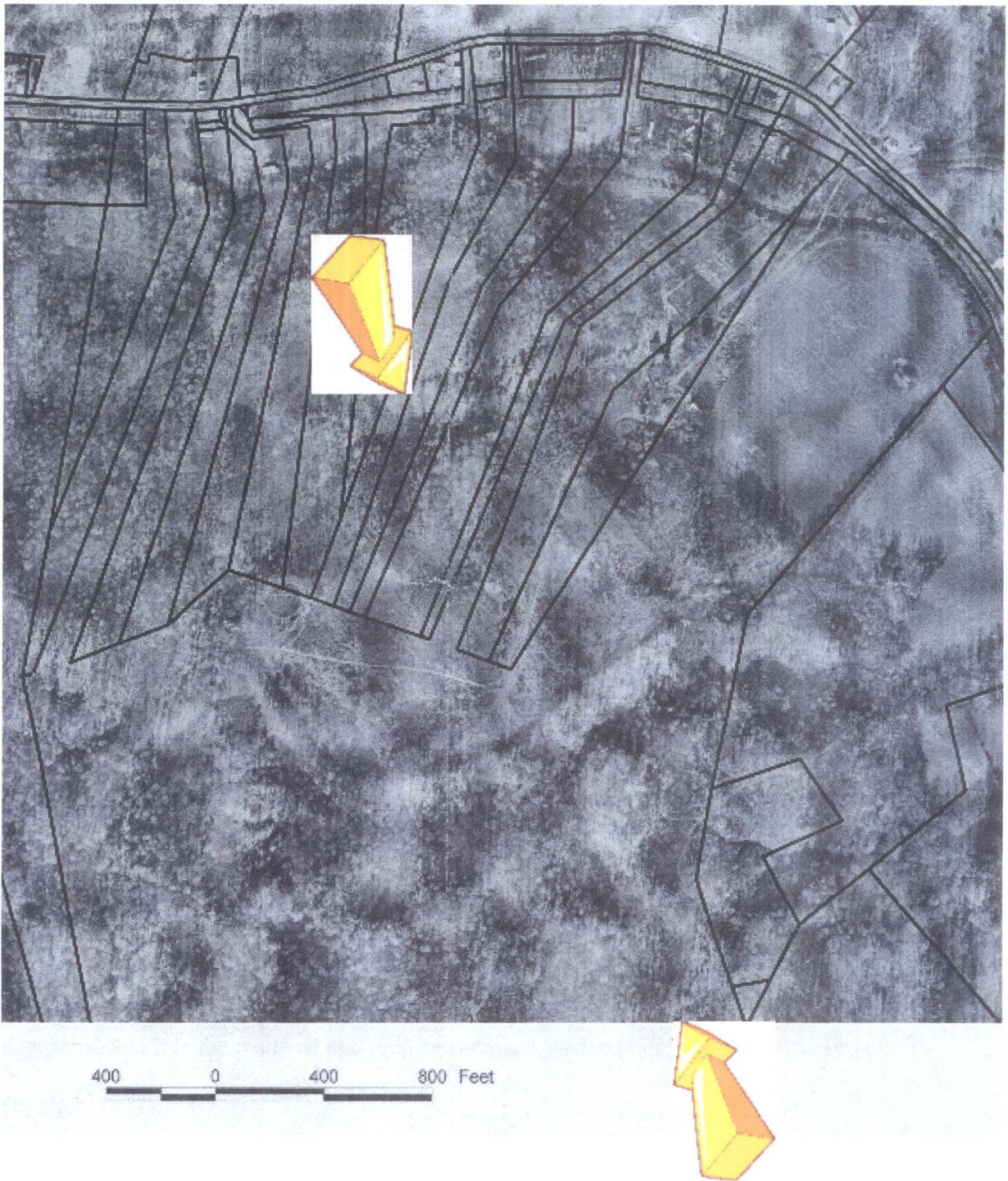

Figure 8.

A. Aerial photograph of the lineation running NNW through the center (between the arrows). North is to the top. Solid black lines are property boundaries.

B.



Figure 8.

B. Four people standing in the groove in the field near Humboldt, Ohio. From left: A neighbor, Steve Hallam, Bill Hallam, and myself. The view is to the East.

SERPENT MOUND - STRUCTURE

The Serpent Mound structure is a major geologic disturbance with a diameter of five miles, located at the common boundary of Adams, Pike, and Highland Counties, Ohio, and there has been considerable debate on its origin (Reidel, 1975). Some researchers think it was caused by meteorite impact (Carlton et al., 1998) whereas others have suggested that it is the result of endogenic processes, such as deep-seated intrusive activity (Bucher, 1921).

SERPENT MOUND - MINERALIZATION

A number of mineral locations in southern Ohio fall within an aureole of mineralization centered on a well-known occurrence of zinc minerals near Serpent Mound. The Serpent Mound zinc district spans seven counties in Ohio: Adams, Brown, Fayette, Highland, Pickaway, Pike, and Ross, but lacks the associated celestite and fluorite that characterize these deposits, except for very small amounts within the actual disturbance itself (Carlson, 1991).

SERPENT MOUND - ORIGIN

Two main branches of thought exist as to the origin of the Serpent Mound Disturbance, one exogenic and one endogenic. The exogenic hypothesis is that an impact by a low density bolide such as a comet head produced the feature. The circular shape of the disturbance, the pronounced central uplift, lack of volcanic material, and presence of shatter cones and the high-pressure quartz polymorph, coesite, support this hypothesis (Carlton et al., 1998). However, it fails to explain the two distinct periods of deformation that reportedly occur at the site (Reidel et al., 1982).

The endogenic hypothesis proposes that released gas from intrusive activity at depth similar to that of a kimberlite intrusion caused an explosion creating the feature. There has been some question as to whether the forces in such an event would have been sufficient to create shatter cones (Reidel et al., 1982). The existence of coesite is the most significant evidence against an endogenic origin, as it is believed to be formed only by impacts.

CONCLUSIONS

Gold flakes and nuggets found in streams in Ross County are glacial in origin as evidenced by the flattened and scratched appearance of the gold under the microscope, the correlation of gold locations with the terminus of the Illinoian glacial advance, and a lack of any evidence of appropriate hydrothermal conditions for its emplacement in Ohio. The paleokarst features present at the Silurian – Devonian contact can be a mechanism for concentration of glacial gold as the stream material washes over and into sinkholes in the area. This provides an explanation for the concentration of gold found at the mine which led to Carlisle's identification of the white layer as a gold-laden quartz vein.

The white layer observed at the Carlisle Mine is the layer referred to in the articles about T. E. Carlisle and the area as 'crumbly quartz'. It is a paleosol, chiefly composed of chert and kaolinite, filling an ancient sinkhole in Silurian Dolomite. Analysis with a scanning electron microscope, using electron dispersive spectrometry, or EDS, confirmed that the white layer is chiefly kaolinite. Bauxite deposits have been known to form from karst features filled by kaolinite which then degraded to bauxite by removal of silica by groundwater (Nesse, 1999).

In the vicinity of the mine, there is a surface lineation visible on aerial photographs and in the field which trends northwest and may indicate an unseen fault or joint plane in the subsurface related to radial faulting from Serpent Mound. Paleozoic sediments have a thickness of roughly two thirds of a mile in this part of Ohio. The formation of the five mile wide disturbance at Serpent Mound undoubtedly fractured the surrounding bedrock all the way down to the basement. This would allow mineralized water to flow upward through otherwise impermeable shale units, thus creating an aureole of mineralization around the disturbance.

SUGGESTED RESEARCH

Research on the glacial and bedrock geology of Southern Ohio is indispensable in understanding the geology of the entire state. Investigation of local rumors may confirm the presence of gold in unglaciated parts of Ohio which would suggest the presence of the metal in Carboniferous or Permian fluvial sedimentary rocks. A thorough study involving isotopic ratios and concentrations of trace elements in mineral crystals would shed new light on the origin of mineralization in the area and give more specific correlation with Serpent Mound features than was possible in the scope of this study. In addition, geophysical research could uncover mineral deposits of economic value or undocumented faults, which have a direct effect on ground water flow and susceptibility to contamination.

Finally, I believe that a comprehensive study of the composition and distribution of crystalline glacial boulders in Ohio, likely employing GIS, would identify their provenance and path of travel during the glacial periods. This would serve two important purposes, both expanding the knowledge of the glacial geologic history of the state and possibly leading to the discovery of yet unknown economic mineral deposits to the north.

REFERENCES:

- Bucher, Walter H., 1921, Cryptovolcanic Structure in Ohio of the type of the Steinheim Basin: Geological Society of America Bulletin, v. 32, no. 1, p.74-75.
- Carlson, Ernest. H., 1991, Minerals of Ohio: Ohio Geological Survey Bulletin 69, 155p.
- Carlson, Ernest. H., 2002, Ohio Mineral Locality Index Part 2: Concretions and Miscellaneous Occurrences: Rocks and Minerals, v. 77, Sept/Oct, p.306-319.
- Carlton, Richard. W., Koeberl, C., Baranoski, M., and Schumacher, G. A., 1998, Discovery of Microscopic Evidence for Shock Metamorphism at the Serpent Mound Structure, South-central Ohio: Confirmation of an Origin by Impact: Earth and Planetary Science Letters, v. 162, no. 1-4, p.177-185.
- Carman, J. E., 1947, Geologic Section of the Chillicothe Test Core: Ohio Journal of Science, v. 47, no. 2, p.49-54.
- Carman, J. E., 1955, Revision of the Chillicothe Test Core Section: Ohio Journal of Science, v. 55, no. 2, p.65-72.
- Clifton, H. Edward, 1957, The Carbonate Concretions of the Ohio Shale: Ohio Journal of Science, v. 57, no. 2, p.114-124.
- Greenfield Republican*, 1933: Unfortunately, I had only a handed-down photocopy of the article from the *Republican*, and I was unable to find anyone who had ever seen an original. The *Republican* told me on the phone that old articles are not searchably indexed, and there was not enough information to determine a more specific date.
- Hansen, Michael C. (compiled by), 1995, Gold in Ohio: Ohio Geological Survey Geofacts Pamphlet, no. 9, 2p.
- Harris, Frank. R., 1955, Hometown Chronicles, Greenfield, Ohio, The Greenfield Printing and Publishing Company, 246p.
- Napper, Charles W., 1917, Concretionary Forms in the Greenfield Limestone: Ohio Journal of Science, v. 18, no. 1, p.7-13.
- Nesse, William D., 1999, Introduction to Mineralogy: Oxford, Oxford University Press, 464p.
- Orton, Edward, 1874, Report on Third District; Geology of Pike County; Ross County; Greene County: Ohio Geological Survey Bulletin, Rp. 2, pt. 1, p.611-696.
- Quinn, Michael J. and Goldthwait, Richard P., 1985, Glacial Geology of Ross County, Ohio: Ohio Geological Survey Report of Investigations 127, 42p.
- Reidel, Stephen, P., 1975, Bedrock Geology of the Serpent Mound Cryptoexplosion Structure, Adams, Highland, and Pike Counties, Ohio: Ohio Geological Survey Report of Investigations 95.
- Reidel, Stephen P., Koucky, F. L., and Stryker, J. R., 1982, The Serpent Mount Disturbance, Southwestern Ohio: American Journal of Science, v. 282, no. 9, p.1343-1377.
- Smith, Kelly. C., 1992, Source and occurrence of placer gold in central Ross County, Ohio [M.S. thesis]: Columbus, Ohio State University, 170 p.
- Sunderman, Jack A., 1980, Outcrop Characteristics and Petrology of a Middle Devonian Bentonite From Northern Indiana: Geological Society of America Abstracts with Programs, v. 12, no. , p. A257.
- Tobin, Don G., 1961, Subsurface Structure from Reflection Seismology in Clinton, Fayette, Highland, Pike, and Ross Counties, Ohio [M.S. thesis]: Columbus, Ohio State University, 77 p.
- Wells, John W., 1942, Pseudo-algal Nodules in the Greenfield Dolomite (Upper Silurian of Ohio): Ohio Journal of Science, v. 42, no. 2, p.53-59.

APPENDIX 1- STRATIGRAPHIC COLUMN

STRATIGRAPHY AND GLACIAL BOULDER DATA AT THE CARLISLE MINE LOCATION

FEET

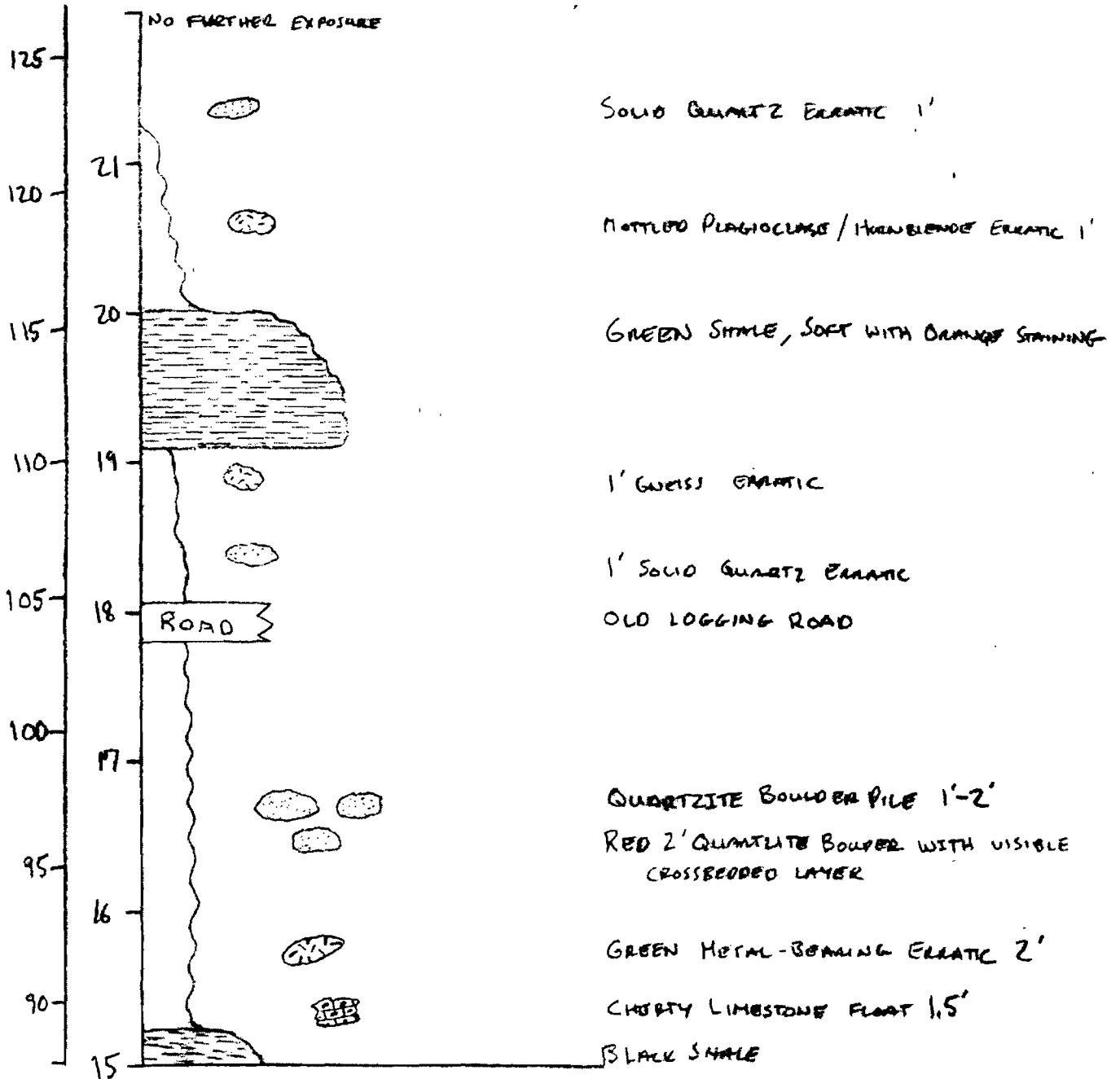

Feet

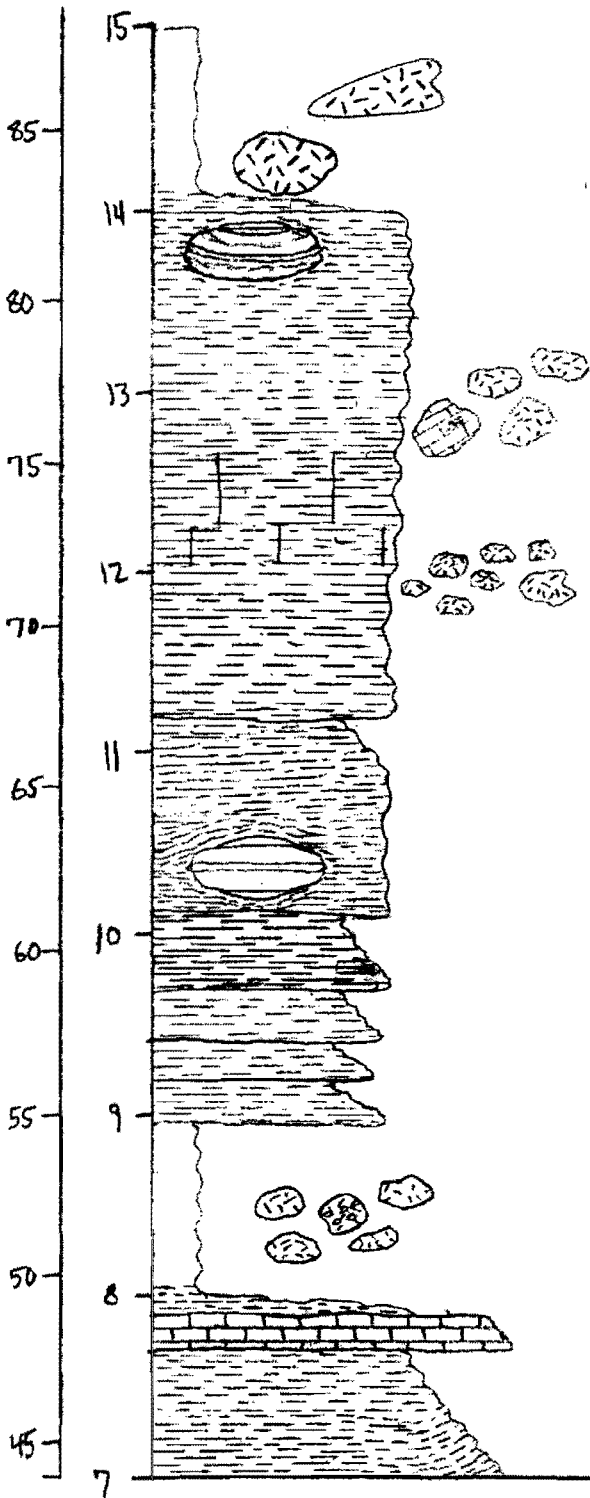

GRANITE BOULDER 4'

GRANITE BOULDER 3'

LARGE CARBONATE CONCRETION 3'

BLACK SHALE, HARD

GNEISS
GRANITE

GNEISS
(S) OLIGONITE FLOAT WITH CRYSTALLINE
JOINTING IN HARD BLACK SHALE (CALCITE)

CRYSTALLINE ORNATICS 6" TO 2.5'

BLACK SHALE, FISSILE, FINELY LAMINATED,
JOINTED.

4' CONCRETION, MAJOR VEINING ON THE OUTSIDE
OF THE DISTURBANCE, VEIN MINERAL (S) SHOW SOME
UV FLUORESCENCE

YELLOW SHALE WITH RED AND ORANGE
STICKY CLAY, POORLY
CONSOLIDATED STAINING

GREEN SHALE - POORLY INDURATED CLAY

GRAY SHALE - SALT AND PEPPER APPEARANCE,
FOSSILS

YELLOW-GREEN SHALE, SOFT, WITH ORANGE STAINING

BOULDER PILE, GRANITES, GNEISSES, ONE WITH
DEFORMED GREEN STRETCHED INCLUSIONS
1/2" LESS RESISTANT PINNACLES, FINE GRAINED GNEISS
1/2'

BLACK SHALE

LIMESTONE/BLACK, HARD LIMESTONE

BLACK SHALE, DEFORMED - SHALLOW UPWARD
BEND AS IT GOES INTO THE BANK

FEET

45
40
35
30
25
20
15
10
5
0

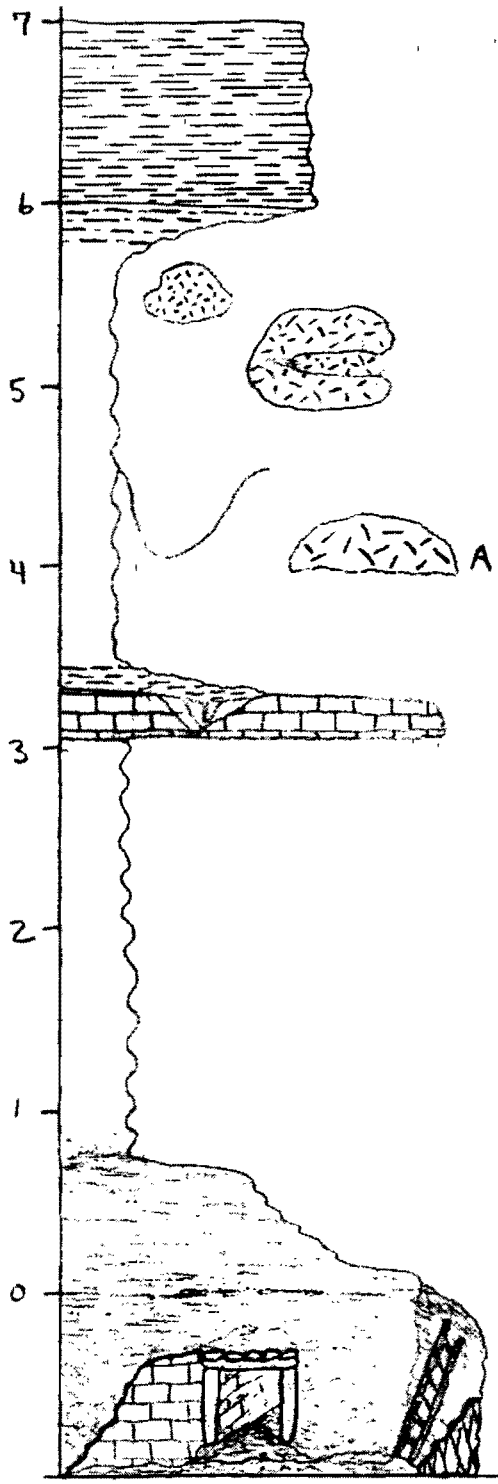

FINELY LAMINATED BLACK SHALE

PURPLE AND GREEN METAL-BEARING SILICEOUS
LARGE BLACK INTRUSIONS (MAGNETITE)

OLD PROSPECT PIT DUG INTO STREAM BANK

LARGE GRANITE BOULDER, PREDOMINANTLY
PINK-RED FELDSPAR

TAN DOLOMITE, HYDROCARBON ODOR ON
FRESH SURFACE

WHITE, ORANGE, TAN CRUMBLY ASH?
LAYER

LINCOLN FACILITY SURFACE
VERY FINE CLAY 1-2" THICK AT BOUNDARY
LADDER

MINE OPENING
GREENFIELD
GORHAMITE-FM - GRAY DOLOMITE VERTICAL COLUMNAR
SURFACE, IRON OXIDE STAINING
AND OENANTHIC PYROLUSITE
ALSO - PSEUDO-ALLUVIAL FEATURES
WATER LEVEL

APPENDIX 2- BEDROCK GEOLOGY MAP

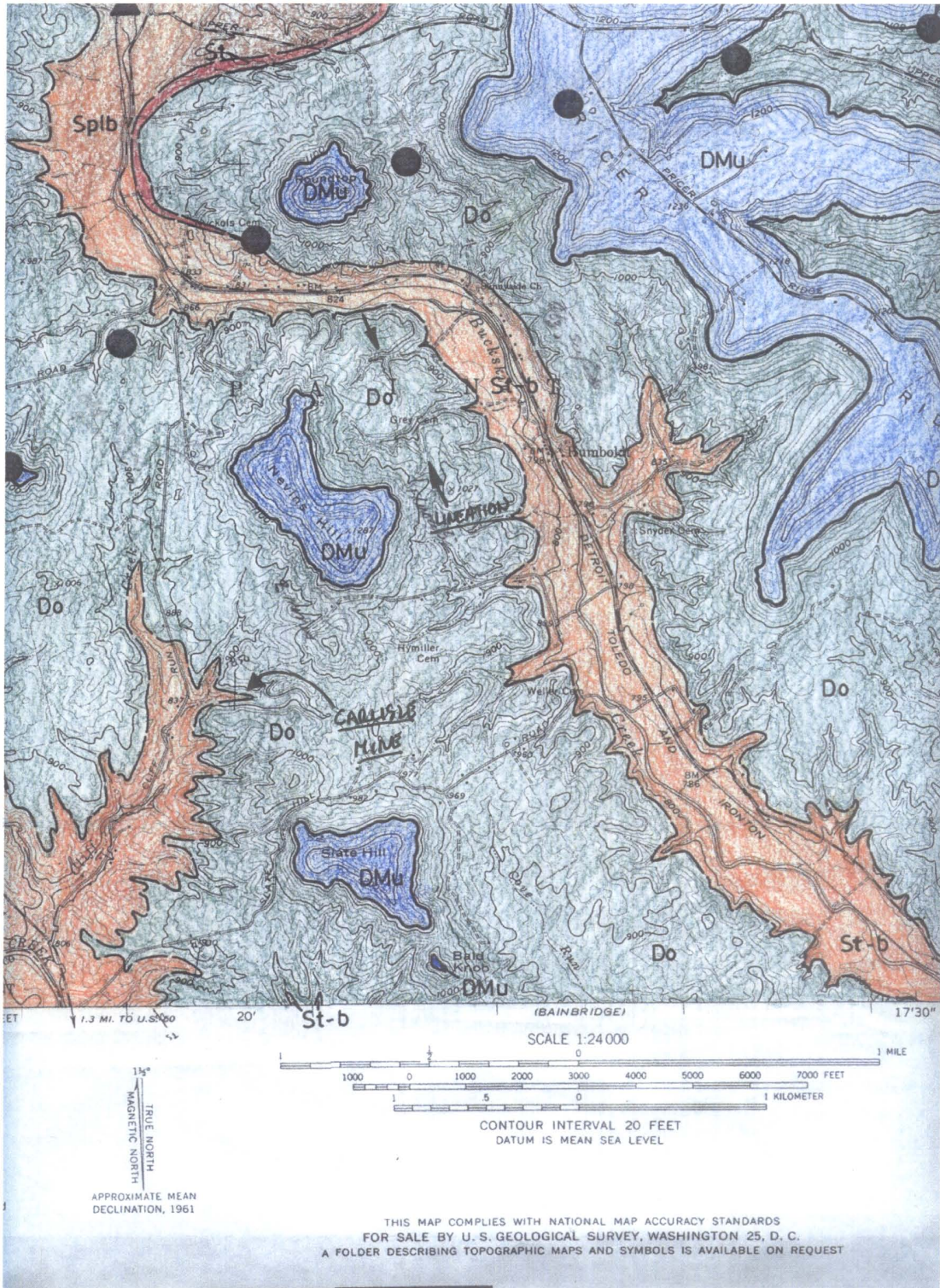

Bedrock geology map of the study area in the southern half of the South Salem USGS 7 1/2 minute topographic quadrangle. Unit boundaries mapped by Gregory A. Schumacher August, 1994, revised August, 2001. Units page 35.

Explanation of Map Units

Bedrock

MISSISSIPPIAN

Mlc

Cuyahoga and Logan Formations undivided

DEVONIAN or MISSISSIPPIAN

DMu

Sunbury Shale, Berea Sandstone, and Bedford Shale undivided

DEVONIAN

Do

Ohio and Olentangy Shales undivided

SILURIAN

St-b

Tymochtee, Greenfield, and Peebles Dolomites and Lilley and Bisher Formations undivided

Ssu

Salina undifferentiated

St

Tymochtee Dolomite

Sg

Greenfield Dolomite

Splb

Peebles Dolomite, Lilley and Bisher Formations undivided

Glacial

Al

alluvium

Wok

KINGSTON OUTWASH

Wg₂

GROUND MORAINES

2
CROSBY TILL (LATAHUS MORAINES)

We₂

EARLY MORAINES

I₁

ICE CONTACT FORMATIONS

I₀

OUTWASH (HIGBY OUTWASH)

I_g

GROUND MORAINES (RAMSBORO TILL)

RECENT

WISCONSINAN

ILLINOIAN

BLACK DOTS AT TOP OF MAPS REPRESENT NORTHERN UNIT OF St-B UNDIVIDED.

APPENDIX 4 – SEM DATA

Sample: Kaolinite
 Fragment of the white layer

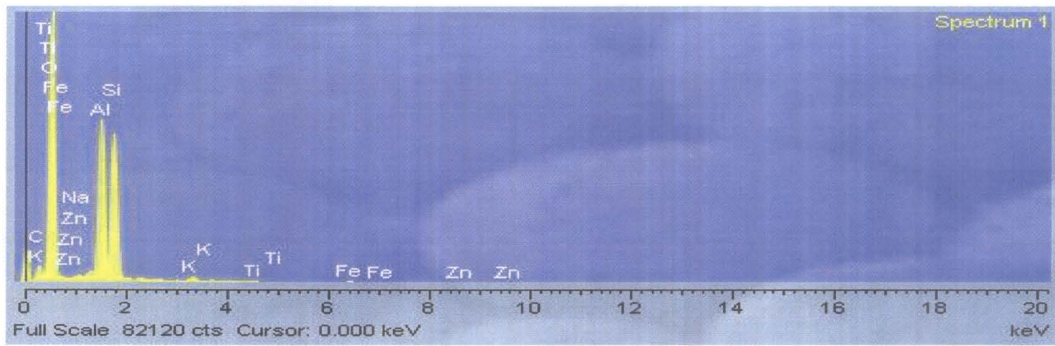
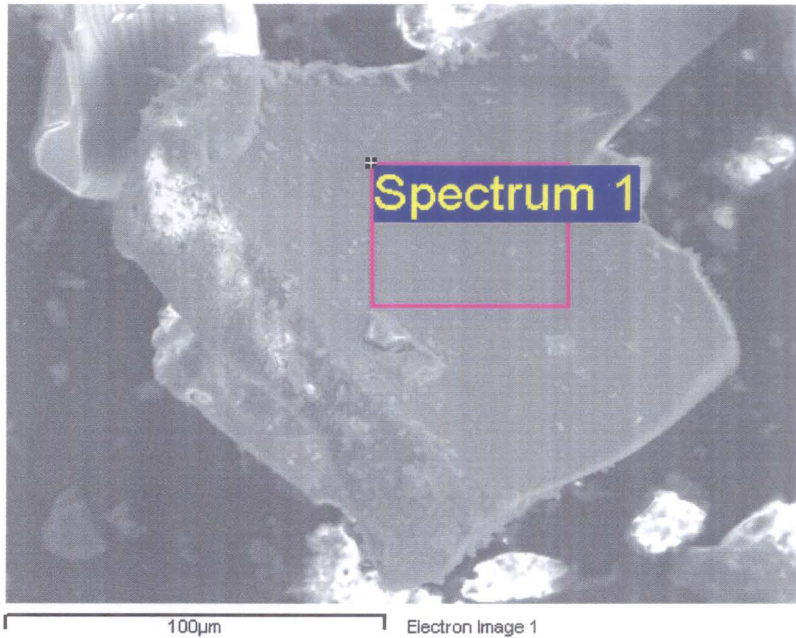

Spectrum processing:
 Peaks possibly omitted: 3.233, 13.220 keV

Processing option: Oxygen by stoichiometry (Normalized)

Element	App	Intensity	Weight %	Weight %	Atomic %	Compd %	Formula	Number
	Conc.	Corn.		Sigma				of ions
C K	12.02	0.1868	7.28	1.01	11.28	26.68	CO ₂	1.41
Na K	0.00	0.9043	0.00	0.00	0.00	0.00	Na ₂ O	0.00
Al K	165.76	1.0083	18.60	0.55	12.83	35.15	Al ₂ O ₃	1.60
Si K	129.45	0.9420	15.55	0.51	<u>10.30</u>	33.27	SiO ₂	1.28
P K	2.78	0.7952	0.40	0.19	0.24	0.91	P ₂ O ₅	0.03
Ca K	14.79	0.9760	1.71	0.23	0.80	2.40	CaO	0.10
Fe K	3.73	0.8666	0.49	0.42	0.16	0.63	FeO	0.02
Zn L	3.66	0.5343	0.78	0.70	0.22	0.97	ZnO	0.03
<u>O</u>			55.19	1.19	<u>64.18</u>			8.00
Totals			100.00					
							Cation sum	4.47

Sample: Barite
 Vein mineral in carbonate concretion.

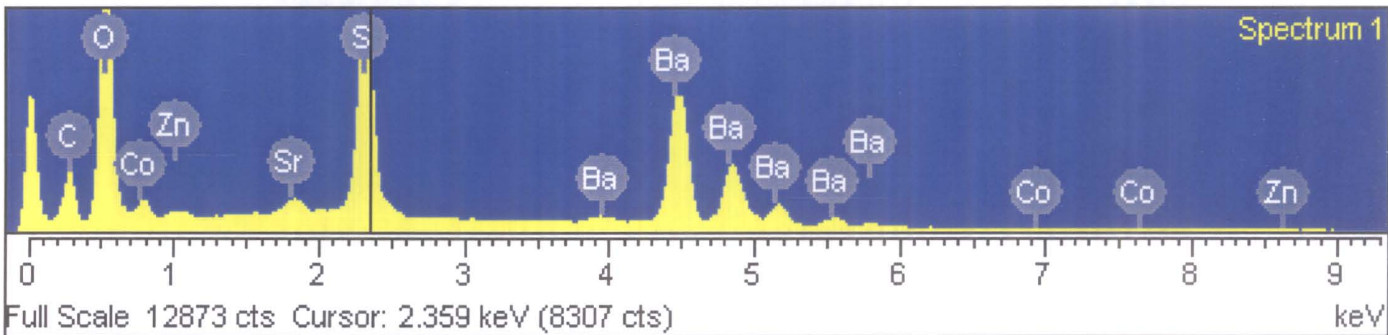
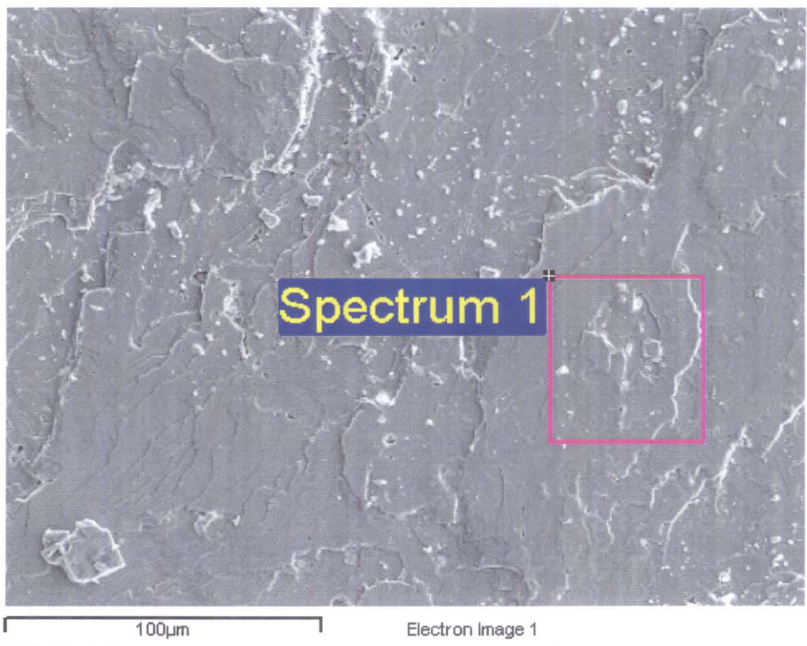

Processing option: Oxygen by stoichiometry (Normalized)
 Number of ions calculation based on 8.00 anions per formula

Element	App	Intensity	Weight %	Weight %	Atomic %	Compd %	Formula	Number of ions
	Conc.	Conn.		Sigma				
C K	10.30	0.3137	8.46	0.47	18.14	31.01	CO ₂	2.18
S K	34.69	0.9644	9.27	0.25	7.44	23.15	SO ₃	0.90
Co K	0.00	0.8733	0.00	0.00	0.00	0.00	CoO	0.00
Zn L	1.55	0.4342	0.92	0.32	0.36	1.14	ZnO	0.04
Sr L	1.70	0.7949	0.55	0.10	0.16	0.65	SrO	0.02
Ba L	141.47	0.9242	39.45	0.73	7.39	44.05	BaO	0.89
O			41.35	0.72	66.51			8.00
Totals			100.00				Cation sum	4.03

Sample: Dolomite
 Crystals from the white layer. These displayed orange fluorescence under shortwave ultraviolet light.

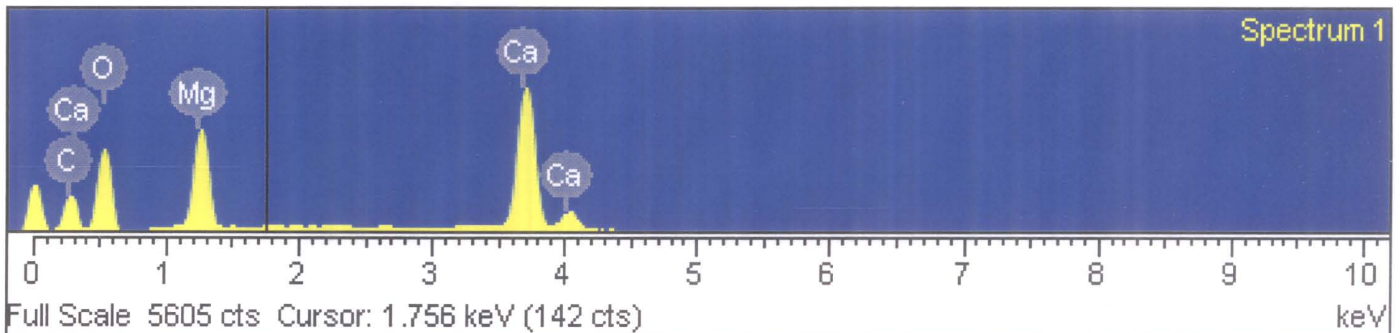
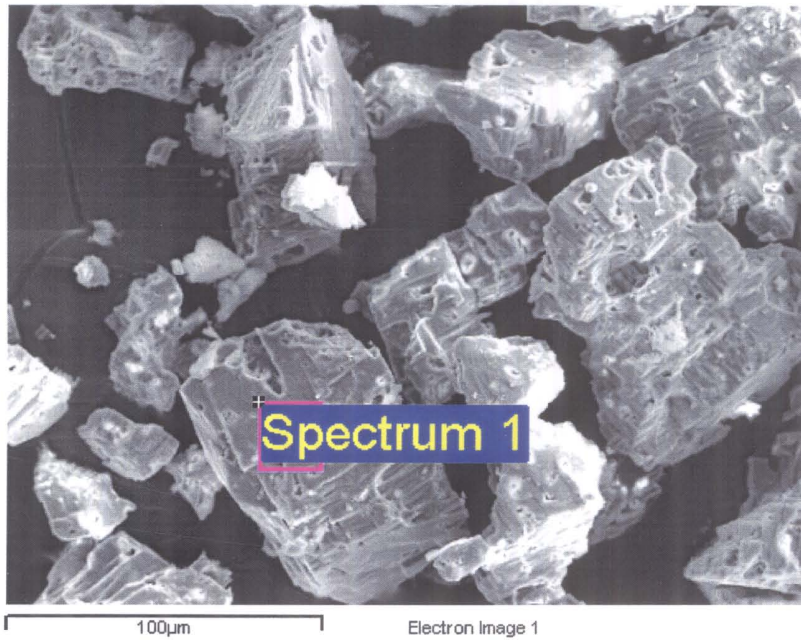

Spectrum processing:
 Peaks possibly omitted: 3.207, 12.300 keV

Processing option: Oxygen by stoichiometry (Normalized)

Element	App	Intensity	Weight %	Weight %	Atomic %	Compd %	Formula	Number
	Conc.	Corrn.		Sigma				of ions
C K	21.73	0.4222	11.04	1.04	<u>17.92</u>	40.45	CO ₂	2.43
Mg K	40.03	0.8001	10.73	0.59	<u>8.60</u>	17.79	MgO	1.17
Ca K	141.26	1.0151	29.85	1.18	<u>14.52</u>	41.76	CaO	1.97
O			48.39	1.39	<u>58.96</u>			8.00
Totals			100.00					
							Cation sum	5.57