

Online Influence Space(s) and Digital Influence Waves: In Honor of Charly

BENJAMIN G. DAVIS AND KEEFE SNYDER*

I. PREAMBLE

A. Historical Citizen Dissent: World War II Opposition to Japanese Internment

Although the efforts of some who opposed removal and relocation were unquestionably inadequate and largely represented compromised positions, the activities of these supporters of Nikkei rights must be understood within their difficult political context. In combination with the submissions made to government officials, the pamphleteering, day-to-day ministering to the incarcerated, numerous petition campaigns, and letters to the editor embodied a creative and eventually effective opposition to the rigid anti-Japanese racism of the day.¹

* Benjamin G. Davis, Associate Professor of Law, University of Toledo College of Law. This paper is written in honor of Charles B. Gittings Jr.. Shortly after 9/11 Mr. Gittings, a computer programmer, created a website entitled the "Project to Enforce the Geneva Conventions," and that website became a source of information regarding matters related to the war on terror. His periodic e-mail updates were an extraordinary example of a citizen influencing others through cyberspace to bring his state into compliance with international law. His commenting in blog venues is another example of his tireless efforts to influence those thinking about international law issues in the war on terror. I hope that readers will look at his remarkable work (<http://www.pegc.us/>).

Keefe Snyder is my research assistant who helped elaborate the images of online influence space based on George Corrin Jr.'s initial picture. I thank George Corrin Jr., who developed the first idea of an online influence space and the cradle of ideas; Alan Gaitenby, Lecturer, University of Massachusetts and Assistant Director, National Center for Technology and Dispute Resolution for his comments on this work; Odette Lagace, Ombudsperson of the University of Laval, Quebec City, Quebec for drawing my attention to Francesco Alberoni; Professor Ian Macduff of Singapore Management University and Professor Kelly Moore for helpful comments in creating this article; and Diane Bitter-Gay for her research assistance. Any errors in the text are the fault of Benjamin G. Davis and should not be viewed as casting any aspersions on my co-author or others whose collaboration has been greatly appreciated.

¹ STEPHANIE BANGARTH, *VOICES RAISED IN PROTEST: DEFENDING CITIZENS OF JAPANESE ANCESTRY IN NORTH AMERICA, 1942–49*, at 71 (2008).

B. Fast-Forward to Current Citizen Dissent

“The ability of networked activists to transform politics in some countries could prove to be the single most important trend in the global Internet culture.”²

II. INTRODUCTION

I thank the *Ohio State Journal on Dispute Resolution* for this opportunity to explore the topic of online influence spaces and digital influence waves. The goal of this essay is to explore online influence space where information technology, dispute resolution, public affairs, international law, domestic law, and both domestic and international citizen activism intersects in creative and eventually effective methods, creating digital influence waves.

I will place these online influence spaces in context with current and earlier physical space influence movements. My method draws from the seminal work of Italian sociologist Francesco Alberoni³ who examined the structure and development of collective movements—from two persons becoming a couple—to broad transnational movements in physical space such as: communism, religion, and feminism from nascent being to becoming institutions. Elaborating on the phenomenon noted in sociology of “two states of the social,” whether in the American sense of “movement” and “social structure” or other contrasting phenomenon such as “community” and “society,”⁴ Alberoni’s magisterial work identifies the development of movements and their institutionalization across historical, social, and cultural contexts. I build on Alberoni’s insights, as well as others, in grasping the concepts of online influence spaces and digital influence waves (movements); especially as these influence spaces collide and interact with physical space structures of power and authority (institutions). The

² JOHN PALFREY & URS GASSER, BORN DIGITAL: UNDERSTANDING THE FIRST GENERATION OF DIGITAL NATIVES 256–57 (2008).

³ See generally FRANCESCO ALBERONI, MOVEMENT AND INSTITUTION (Patricia C. Arden Delmoro trans., Columbia University Press 1984)(1977); FRANCESCO ALBERONI, L’AMITIE (Ramsay 1985)(1984); FRANCESCO ALBERONI, LE CHOC AMOUREUX (Ramsay 1981)(1979). Alberoni analyzes social movements from movements of two people (falling in love and friendship) through mass worldwide social movements analyzing the manner in which the creative idea turns into a nascent state, and then a movement. The interaction with and changing of institutions as the movement may itself become institutionalized, extinct, repressed, or be dissolved in illusion.

⁴ ALBERONI, MOVEMENT AND INSTITUTION, *supra* note 3, at 1–3.

ONLINE INFLUENCE SPACES(S) AND DIGITAL INFLUENCE WAVES

institutions become, at least and in turn, online institutions born of an initial movement.

Online influence spaces are relatively new phenomena, and contain structures that permit diversity in their creation. From a listserv with a thread of conversation; blogs and the structure of idea and comment spaces; *Facebook* and the structure of “friending” spaces; through texting and cellphone ubiquity in helping groups self-organize; to *Twitter*’s immediacy, the common thread of online influence spaces is that the individual can interact with others regardless of borders or time. The ability to transport across the world and interact with others permits the development of commonalities and affinities in short time—developing collective movements across national boundaries, physical spaces, and time. Collective movements aid in mobilizing activism that is geographically specific (e.g. a situation in a specific town or country), or across national boundaries to broadly help engender a common development on a given theme (for example, torture in the world). Therefore, add technical development to generational transition from digital immigrant⁵ parents to digital native⁶ children, and I suspect that emerging social mobilization structures—made of diverse, still evolving technologies—will be present for the foreseeable future. In short, this article is a meditation on emerging influence spaces and what they portend for lawyers and law students in their careers.

One of the key actions lawyers do, beyond the courtroom, is to use Alternative Dispute Resolution (ADR) processes to seek certain client outcomes. Therefore, it is important that we think about online influence spaces in the ADR context. Thinking of ADR only in the physical space is self-limiting, as the influence spaces we experience are both physical and online. Particularly for individuals outside positions of power in strong institutions, the atomized possibilities of coalescing, aggregating, and mobilizing individual concerns about a specific issue, problem, etc., permitted through online influence spaces are means of giving vent to those aspirations. The success of the achievement of those aspirations may help

⁵ David Allen Larson, *Technology Mediated Dispute Resolution (TMDR): Opportunities and Dangers*, 38 U. TOL. L. REV. 213, 217–21 (2006). I am a fifty-three year-old professor who has grown up with the information technology revolution largely occurring in the second half of my life (circa 1983 forward). This accident of timing makes me what has been termed a “digital immigrant.” *Id.* at 218. This is in contrast with those for whom information technology is an integrated part of the way the world has been for all of their life. Such is the situation of most of our students who some have termed digital natives or born digital. *Id.* See generally PALFREY & GASSER, *supra* note 2. Yet, whether immigrant or native, we operate in both physical and online.

⁶ See PALFREY & GASSER, *supra* note 2, at 1–2.

provide meaning to individual intuitions and, possibly, help humanity progress.

For law professors, in the past one, would await a law review publication in physical space to send to colleagues, participate in an amicus brief brought together through phone, telefax, and mail contacts. Law professors can continue these traditional actions, however; they can even more quickly disperse their ideas and respond to others' thoughts through posting versions of their work in online spaces (like SSRN), being active in blogs or listservs, and acting through new technologies (*Twitter, MySpace, Facebook* etc.). The online space is not just a connection space that permits quick communication with others across vast distances. The online space creates acceleration in the dissemination of ideas and more rapid possibilities for ideas to have influence by: 1) facilitating the possibility of access (or at least apparent access) to others including those with power; and 2) accelerating the process of aggregating complimentary views into national and transnational digital influence waves. Access and digital influence waves, in turn, shift opinion that may lead to significant physical space changes.

As we prepare our students to become attorneys, both now and in the future, it appears that examining this underexplored online influence space—a potentially significant development of massive multi-person negotiation and mediation—merits reflection by ADR scholars. My hope is that this paper will assist teachers and students in seeing the possible significance of integrating online influence spaces to address problems that occur during a legal career. If ordinary citizens have access to other individuals through technology, then there is a potential online influence space that magnifies the possibility of that citizen's influence. The same technological influence applies for lawyers, law professors, and law students as they endeavor to influence the nature of the law and its implementation.⁷

A. *Context—Physical or Offline Influence Spaces*

Whether on the village green, street corner, town hall, union meeting hall, board meeting, or faculty meeting; influence spaces are ubiquitous in the physical world. In physical spaces, citizens conduct activities that influence others, and can become collective movements of a massive scale. Sometimes these activities occur to change, modify, or adapt a given policy of the state. Other activities are concerned with modifying a given community, and less with structures of political power and authority. These

⁷ This article is one part of my broader effort to explore the citizen's role in state compliance with international law.

ONLINE INFLUENCE SPACES(S) AND DIGITAL INFLUENCE WAVES

physical influence spaces are significant because—unlike the established structures or institutions—these activities may be initiated by those without the levers of power (at least in the nascent form), and by powerless individuals. Yet, through their efforts, individuals can grow the nascent idea into massive collective movements that have changed the world—or at least parts of it.

Consider moments in American history where private citizens successfully influenced the American state to change, modify, or adapt a given policy. The image here is broader than lobbying Congressional members or filing civil suits in court seeking remedy for an alleged constitutional or statutory violation. I am thinking about activities by citizens such as petitioning, demonstrating, civil disobedience, writing to Congresspersons, campaign contributions, speaking in public, and other concrete steps—alone or aggregated in groups that gain influence—to push the law, and the implementation of that law. Private citizens coalesce to influence their fellow citizens and their governments to change American society in fundamental ways.

One can look back to Bacon's Rebellion in 1676, in which white indentured servants and black slaves jointly rebelled in Virginia because of their treatment at the hands of the Governor of Virginia.⁸ Led by Nathaniel Bacon, seeking an aggressive anti-Native-American policy, Bacon's Rebellion by the underclass (led by a member of the elite) resulted in increased differentiation between those of European descent and those individuals of African descent. Bacon's Rebellion created freedom for the white indentured servants and hardened slavery for those of African descent—an action that spread throughout the nascent country as the slave economy came into full force in colonial America.⁹

One can look back to 1692, and octogenarian Giles Corey, one of the men executed as a witch during the Salem Witch Trials.¹⁰ Corey refused to participate in the hysteria that gripped Salem, and was in turn accused to be a

⁸ Interview with Ira Berlin, Professor, University of Maryland (June 24, 2009), available at http://www.pbs.org/race/000_About/002_04-background-02-08.htm; see also PBS, Bacon's Rebellion, <http://www.pbs.org/wgbh/aia/part1/1p274.html> (last visited Sept. 27, 2009). Berlin states that: "Bacon's Rebellion demonstrated that poor whites and poor blacks could be united in a cause. This was a great fear of the ruling class—what would prevent the poor from uniting to fight them? This fear hastened the transition to racial slavery." *Id.*

⁹ Berlin, *supra* note 8.

¹⁰ Douglas Linder, *The Witchcraft Trials in Salem: A Commentary*, http://www.law.umkc.edu/faculty/projects/ftrials/salem/SAL_ACCT.HTM (last visited June 24, 2009).

witch. Refusing to stand trial, Corey was punished by “pressing,” crushed to death under rocks.¹¹ As Corey lay strapped in with heavier and heavier stones laid on him, Corey was asked by the authorities to confess to being a witch, agree to stand trial, or have more rocks piled on him.¹² Corey's response, a remarkable image of principle maintained in the direst of circumstances was to say with his dying breath, “[p]ut another rock on!” Corey's defiance of the accumulated power of the state protected the inheritance of his children from confiscation by the state.¹³ Corey's example helped end the Witch Trials.

One can look to 1770, and like any American student, will remember both elementary school and learning about the Boston Massacre. The Boston Massacre, in its civilian-military tension, culminated with the death of Crispus Attucks at the hands of the British.¹⁴ Attucks' actions and death galvanized the American Revolution.

We should remember the abolitionists, domestically and international, who founded the Abolitionist Societies and the Anti-Slavery Society. These abolitionists, through domestic citizen action, and in concert with international citizens (including Lord Wilberforce in England), brought an end to the transatlantic slave trade—notwithstanding the structural acceptability of slavery for centuries in many countries, especially the United States.¹⁵ We should remember the individuals, in many places (including Ohio), who provided safe haven for slaves (or “freedom seekers” as termed by Native-Americans in Northwestern Ohio), to reach Canada and to freedom.¹⁶

¹¹ *See id.*

¹² For a description of Mr. Giles' untimely death, see Biography of Giles Corey, http://www.law.umkc.edu/faculty/projects/ftrials/salem/SAL_BCOR.HTM (“On Monday, September 19, Corey was stripped naked, a board placed upon his chest, and then—while his neighbors watched—heavy stones and rocks were piled on the board. Corey pleaded to have more weight added, so that his death might come quickly.”).

¹³ Presentation at the Salem Witch Museum, Salem, MA, June 15, 2009.

¹⁴ *See* Boston Massacre Historical Society, Crispus Attucks, <http://www.bostonmassacre.net/players/crispus-attucks.htm>. (last visited Sept. 29, 2009).

¹⁵ *See* IAN CLARK, INTERNATIONAL LEGITIMACY AND WORLD SOCIETY 37–60 (2007); MARY STOUGHTON LOCKE, ANTI-SLAVERY IN AMERICA FROM THE INTRODUCTION OF AFRICAN SLAVES TO THE PROHIBITION OF THE SLAVE TRADE, 1619–1808, 9–155 (1965). *See generally* LOUIS FILLER, THE CRUSADE AGAINST SLAVERY (1960)

¹⁶ *See, e.g.*, Underground Railroad of Ohio, <http://www.rootsweb.ancestry.com/~ohfulton/UNDERGROUNDRAILROADOFNWOHIO.htm> (last visited on June 24, 2009).

ONLINE INFLUENCE SPACES(S) AND DIGITAL INFLUENCE WAVES

We should not forget the organization of whites in the South into groups such as the Ku Klux Klan in the post-Reconstruction period of Restoration, through which the efforts toward equality of blacks were thwarted by both violent and non-violent means.¹⁷ Those actions, while retrograde, do represent another aspect of citizen influence in physical space that became very significant at the turn of the twentieth century.

We should remember those American citizens who worked actively against, and dissented during the hysteria regarding Americans of Japanese descent in World War II.¹⁸ As Japanese-Americans were rounded up and sent to internment camps, individuals protested this betrayal of American ideals, defending the citizenship rights of those who were disfavored; doing so notwithstanding the hysteria and the risks of disapprobation.¹⁹

We should think of the many heroes and heroines, and unnoticed but important individuals, in the civil rights movement who worked in their communities, or came to communities oppressed by segregation seeking justice for the disfavored. We should think of the lawyers like Thurgood Marshall in the 1940's and 1950's who carefully exercised citizen rights in legal proceedings, while others, through citizen activism in the streets used

¹⁷ Efforts to disenfranchise blacks culminated in 1901 with the resignation of George White as Representative of North Carolina, thus eliminating all black representatives from the South. See PBS, *Congressman George White*, <http://www.pbs.org/wgbh/amex/1900/peopleevents/pande7.html> (last visited on June 24, 2009). For George White's farewell address to Congress, see Speech of Hon. George H. White, of North Carolina, in the House of Representatives (Jan. 29, 1901), available at <http://docsouth.unc.edu/nc/whitegh/whitegh.html>.

One might find it curious that a retrograde private citizen effort like the Ku Klux Klan should be mentioned in this space, but it was an extremely powerful force in American society in the late 19th and turn of the 20th century. It should also be noted that many stories of resistance may be lost to time. One story involved a black North Carolina farmer who said that the Klan would inform blacks in their area of when they were going to march. Interview with Zeno White, in Toledo, Oh (June 26, 2009). This North Carolina farmer would have his five children go under the house with rifles with instructions to shoot any Klansmen who came on the property which he owned. *Id.* In a form of détente, the Klan would warn its members not to step onto "Coon" White's property. *Id.* That family story is now preserved for posterity.

¹⁸ See generally BANGARTH, *supra* note 1; Charles Davis & Jeffrey Kovac, *Confrontation at the Locks: A Protest of Japanese Removal and Incarceration During World War II*, 107 OR. HIST. Q. 486 (2006), available at <http://www.historycooperative.org/journals/ohq/107.4/davis.html>.

¹⁹ Davis & Kovac, *supra* note 18.

non-violent civil disobedience to move the country away from state-enforced segregation of blacks.²⁰

I evoke this history as a means to remind the reader of citizen-initiated actions, some of which have turned into movements and institutions with power. More precisely, specific individuals have alone or later joined with others in privately organized groups regarding concerns about how the state operates. Those ad hoc groups have evolved into institutions—institutions that, while private, learned how to exercise the levers of power, and therefore exert power to advance their cause. And, that exercise of power has been a means to influence the state, and to cause it to change or acquiesce to the outcome desired by citizen activists.

The aforementioned path was explained to me by one of the architects of the European Union—Michel Gaudet—in saying that people have ideas, people create institutions to preserve the ideas, the institutions have power, and the question for the institution is what it will do with its power. If institutions lose the power of their initial reason for creation, or diverge too dramatically from it, new people with new ideas may come forward and threaten the privileges of the institution. In that battle between the new idea (or refounded core idea) and the institution (as it has evolved from its initial creation), both those asserting the idea and the institution are changed, possibly re-centering the institution on its core mission and giving meaning to the persons who took it upon themselves to initiate that process.

I seek to honor those people with the ideas who, for reasons only known to them, dissent from the status quo, seeking meaningful change, hoping they will help humanity progress. It is through the process of self-actualization of these people that we read stories of the Mother Teresa's, the Martin Luther King's, the Mahatma Gandhi's, and the Thurgood Marshall's. The curious thing in citing such names for purposes of this work is that what these persons did essentially occurred in the pre-digital age of physical space movements. Obviously, television, radio and other mass communication devices played a role in developing the activities and powers of these persons, but that role was qualitatively different from what is going on in online influence space for reasons described in the next section.

²⁰ See generally TAYLOR BRANCH, PARTING THE WATERS: AMERICA IN THE KING YEARS 1954–63 (1988); TAYLOR BRANCH, PILLAR OF FIRE: AMERICA IN THE KING YEARS 1963–65 (1998); TAYLOR BRANCH, AT CANAAN'S EDGE: AMERICA IN THE KING YEARS 1965–68 (2006); MICHAEL D. DAVIS & HUNTER R. CLARK, THURGOOD MARSHALL: WARRIOR AT THE BAR, REBEL ON THE BENCH (1992); CARL T. ROWAN, DREAM MAKERS, DREAM BREAKERS: THE WORLD OF JUSTICE THURGOOD MARSHALL (1993).

B. Context—Online Influence Spaces

While the cases above are diverse, the common denominator is that these were movements that operated in the real world—physical or offline influence space. Local movements were built through personal contact and action in the offline space. These movements also became known to broader constituencies through the exploitation of the technological media available at that time—the press, pamphlets, posters, telegraph, telephone, and television.

Citizen activism in offline space is a form of multi-person dialogue and negotiation to influence the direction of the state and thus America.²¹ All of the above examples are situations that occurred in the offline environment. While media, from newspapers to television, provided increasingly universal access to information about these activities, spreading their influence. It is to be noted that structures of information also served as a filter regarding what would be permitted within their pages (or news programs) and what would be excluded. By the obvious pressures of time and space availability, a prioritization of the dissemination of information about these actions was necessary. More viral means of information dissemination through word of mouth, phone banks such as in unionization movements or political processes, or good old door-to-door canvassing could be used to mobilize people; but, these other means of organization also confronted the physical limitations of those seeking to coalesce citizens together, and the financial hurdles that come with building and sustaining such efforts. I will call this range of activities and the dissemination of their impact “the offline influence space.”

We might analyze the actions of organization of citizen movements in offline influence space through organization behavior-type analysis; but, my experience suggests the inadequacy of offline process modeling. While there is work on the nature of interactions in the online environment in contrast to the offline environment,²² or on specific forms of social networking and how to take advantage of it,²³ it appears to me that the intersection between

²¹ No doubt more cases could be found to discuss in the United States. We must bear in mind that such activism occurs in other countries where citizens have sought to influence their compatriots to change the direction of their state and other states.

²² For a number of perspectives on the phenomenon of online dispute resolution, see generally Symposium, *Enhancing Worldwide Understanding Through Online Dispute Resolution*, 38 U. TOL. L. REV. 11 (2006).

²³ For an excellent resource on how to exploit social networking technologies for commercial success see CHARLENE LI & JOSH BERNOFF, *GROUNDWELL: WINNING IN A WORLD TRANSFORMED BY SOCIAL TECHNOLOGIES* 65–198 (2008).

offline and online influence spaces, and the dynamic between different technology platforms and offline hierarchies is an arena that merits attention in legal education.²⁴ The reason is that individuals may magnify their personal impact through accessing the online space in a sophisticated manner. Offline suppositions of appropriate process for how ideas are to blossom, and have power and influence, can be sidestepped through the building of a wave or waves of online support for an idea. These waves, both built massive multi-person and with distributed efforts, give an idea its immediacy and build its power and influence. The interchange of the actors in the online space can help to hone and enhance the power of an idea, educate, and help in creating new paths of dissemination of the idea. The directions of these types of impacts are not hierarchically or centrally controlled, but seem to go in a series of less coordinated, but faintly harmonious, movements in a similar direction—like seawater and sea currents. With time, such online movements can also move the state to develop new rules, comply with old rules, or depart from past rules.

Thinking about the importance of online spaces in helping create offline consequences is a useful exercise for law students looking to be influence merchants in the future—whether as norm entrepreneurs or norm destroyers. At the same time, this work should be of interest to those familiar with offline hierarchies and wish to preserve institutions of power by making sure that online influence spaces do not destabilize prestige and influence. Moreover, the lack of impediment to offline structures using the exact same levers as individuals to exploit the online spaces to their advantage—reinforcing the hierarchical power rather than subverting the hierarchical power of institutions—is a development that must also be evaluated. We must remember that online influence spaces must also be understood for what they are. Just as in offline space, there are hierarchies related to design in the online influence space that, will affect the potency of efforts in those spaces. The hidden hierarchies of the online influence spaces are important to note so that we can understand the technology mediating in a given space is already the subject of choices that will filter the ability to convince

²⁴ We might say that the Iranian Twitter revolution has pushed this reflection in recent months. See GlobalPost, *How to Run a Protest Without Twitter*, <http://www.globalpost.com/dispatch/worldview/090619/mass-protests-methods> (last visited Oct. 16, 2009); Chip Pitts, CRS Law: Technology, Business & Democratic Rights in Iran, <http://www.iraniantrade.org/update/news.asp?Id=3064> (last visited Oct. 16, 2009). For a more general commentary on modern social movements, see also Lauren Langman, *From Virtual Public Spheres to Global Justice: A Critical Theory of Internetworked Social Movements*, 23 SOC. THEORY 42 (2005), available at <http://www.jstor.org/stable/4148893>.

ONLINE INFLUENCE SPACES(S) AND DIGITAL INFLUENCE WAVES

individuals seeking to cause influence and change. Finally, just as the citizen can access online spaces, the state can also access them to dominate influence spaces, both online and offline, or repress dissent. In the middle are technology companies that may be faced with corporate social responsibility issues, both national and transnational, if states take coordinated efforts to suppress citizen initiatives that have developed from cross-physical border digital influence waves.²⁵

I should note that my task here is both narrower and broader than the work of some colleagues. Thus, I am less concerned about the “public forum” and “complete filtering” leading to “inert people” and other concerns of Cass Sunstein.²⁶ Alberoni points out the nature of the movement and contrasts it with institution, suggesting that online processes may work in a similar manner in both movement and institutional settings—the question that arises is the state of the citizen and whether they seek to act on those spaces, or be acted upon.²⁷ Similarly, I am more modest than others about the nature of the online influence spaces having a possible redefinitional role in the nature of democracy.²⁸ I do not feel the confidence to posit a grand utopian, or dystopian, vision about the online influence spaces and digital influence spaces. I follow in the path of those, such as Ian Macduff, who are struck by a possibly emerging phenomenon, and seek to identify a few paths of that development.²⁹ This work, while more modest than grand theory, may

²⁵ See MICHAEL KERR, RICHARD JANDA & CHIP PITTS, CORPORATE SOCIAL RESPONSIBILITY: A LEGAL ANALYSIS 532–37 (Chip Pitts ed., 2009). The complexity of the corporate technology company role as a source of access and source of oppression is too broad for this paper, which is focused more on the individual influencing the state aspect of this picture. The individual’s ability to adapt to the state oppression, even through technology, is a reaction that also must be kept in mind. We are speaking of a dynamic space of evolving influence tangles.

²⁶ See CASS SUNSTEIN, REPUBLIC.COM 14, 27–37, 98 (2001).

²⁷ Alberoni describes how individual citizens suffer a depressive overload that causes an idea to emerge. This idea places the citizen in a nascent state where they seek to restructure everyday life by means of a movement. This process, based on eros, interacts with institutions and results in one of four phenomena: (1) dissolution of the nascent state phenomena in illusion; (2) repression in bloodshed; (3) institutionalization; or (4) extinction. ALBERONI, MOVEMENT AND INSTITUTION, *supra* note 3, at 60–104, 160.

²⁸ See STEPHEN COLEMAN & JOHN GÖTZE, BOWLING TOGETHER: ONLINE PUBLIC ENGAGEMENT IN POLICY DELIBERATION 8 (2001), available at <http://www.bowlingtogether.net/bowlingtogether.pdf>.

²⁹ See Ian MacDuff, Victoria University of Wellington, N.Z., Keynote Paper at the First International Congress on Conflict, Conflict Resolution and Peace: From Digital Deals to Cyber Citizens: ICT, Online Dispute Resolution, and Civic Dialogue (October 2007), available at <http://www.uoc.edu/symposia/pau/art/Macduff.pdf>.

in fact be of greater significance in charting an emergent phenomena, rather than being a disquisition on that phenomenon. My route to this approach is through my meditations on three cases discussed below.

Yet, in the modesty of the approach, there is breadth, in that the phenomenon described are not just limited to political economy, but to other social and cultural contexts in which online influence spaces and digital influence waves might act upon broader cultural phenomenon. To use a metaphor, I am looking at cases in which digital water reaches its influence level, and not at water level grand theory. In doing this, I am decidedly not persuaded by certain structural visions of digital space, such as Lawrence Lessig's "code is law" vision.³⁰ Code has never been law; code is contract and, contract is law. I only share an interest with those "code-talkers" in that the digital space is a space—a remarkable space—of private ordering. My examination is of private ordering to influence movement and institution, coming back to Alberoni's "two states of the social."³¹

II. CASE STUDIES IN ONLINE INFLUENCE SPACES

In this section, I examine three cases of online influence spaces and digital influence waves that I thought were interesting expressions of this phenomenon. First is the process of passing the American Society of International Law's 2006 Centennial Resolution on the Laws of War and Detainee Treatment; second is the *Volokh Conspiracy* blogspace (www.volokh.com); and the third is the dynamic of President Obama Administration's online access (whether real or ersatz is a subject to be debated) for citizens to have closer connection to their government.

A. *Setting the Scene*

As I have worked against torture for five years, the idea of the citizen's role in gaining the state's compliance with international law obligations became a focus of my research. In thinking about the citizen's role it became apparent to me—possibly because I am more digital immigrant than digital native,³² unlike my younger colleagues—that it would be useful to think more deeply about how online space and offline space interact to maximize, or minimize, the influence of the citizen.

³⁰ See LAWRENCE LESSIG, CODE AND OTHER LAWS OF CYBERSPACE 3-8 (2009).

³¹ See ALBERONI, MOVEMENT AND INSTITUTION, *supra* note 3, at 3.

³² See Larson, *supra* note 5.

ONLINE INFLUENCE SPACES(S) AND DIGITAL INFLUENCE WAVES

Having structured online spaces for the International Competitions for Online Dispute Resolution³³ since 2000, I was aware of how the shape of the online space could dictate or influence the alternative dispute resolution dynamic.³⁴ Working on a topic that was not a discrete ADR issue, but using the skills developed in my ADR experience, it appeared that it might be useful to try to develop some thoughts on the structures in online space, the control mechanisms for those structures in online space, the potential consequences of those structures, and control decisions on citizen-level influence on the major issues of the day.

From this experience, I suspected that issues of structure, control, and therefore, influence in online space are not issues that relate solely to a certain set of technology choices or ADR skill sets. Rather, the interaction between negotiation or mediation skills, and negotiation or mediation environments, of which we are aware in the offline world would necessarily be a subject in the online space (for example, whether caucusing spaces are available in an online mediation).

From the literature I noticed discussion of technology mediated communications and the impact of social networking software.³⁵ What I wanted to address was something a bit different and more conceptual about the dynamic in certain types of discrete online spaces and the relationship to the offline world.

My modest experience with online paths of influence tells me it is important, for lawyering in the future, that students of the law reflect on the manner in which online influence spaces may be accessed and used, in order to push forward agendas of clients and citizen activists to modify local, state, and foreign state compliance with law. While there is literature on the impact of interactions in the online environment, in contrast to the offline environment,³⁶ and on specific forms of social networking (and how to take advantage of it),³⁷ the actual case studies and reflection on these online influence spaces and their dynamic impact on influence appears to be a relatively underexplored area in alternative dispute resolution.³⁸ Moreover,

³³ See generally Benjamin G. Davis, *Walking Along in the Mission*, 38 U. TOL. L. REV. 1 (2006).

³⁴ See generally Alan Gaitenby, *The Fourth Party Rises: Evolving Environments of Online Dispute Resolution*, 38 U. TOL. L. REV. 371 (2006).

³⁵ See generally Larson, *supra* note 5.

³⁶ *Id.*

³⁷ See generally LI & BERNOFF, *supra* note 23.

³⁸ Larson's work is pioneering in this area. See Larson, *supra* note 5.

initiatives such as the Obama Administration's Open Government Effort,³⁹ seeking to enhance citizen input into governance, in some type of bottom-up manner, suggest that offline hierarchies recognize the need to reflect on paths of access to power—to possibly streamline hierarchies, to reduce hidden filters, to provide more direct access to governmental power for those who are ill-organized and cannot exert influence through the traditional offline methods. These processes, however, engender new, possibly more hidden, hierarchies—which we may need also to think about in order to understand what we are going through, and who is really influencing whom.

B. Methodology

To assist reflection, I present this paper through a series of case studies and models. First, I look at the development of the Centennial Resolution on the Laws of War and Detainee Treatment in 2006 by the American Society of International Law, and the failed effort to address some of the same issues in another resolution in 2008. A key aspect of the 2006 resolution was the intersection between the assumptions of how resolutions would occur within the organization and the impact of the online influence space then available, entitled the ASILForum listserv. In addition to the adoption of the resolution—one of only eight made in the 100-year history of the organization—the American Society of International Law changed its approach to resolution consideration. The change made the 2008 resolution, and any future efforts to develop resolutions of the same type, more difficult. Citizen creativity, followed by institutional adjustment, to maintain hierarchical control is one of the themes of this reflection.

I next look at the current evolution of blog space through the lens of the *Volokh Conspiracy*. The structure of a blog is examined; the control mechanisms, the hidden hierarchies, and the evolution of the comment policies are key aspects of this space. While everyone with internet access is free to build a blog, thinking about the control mechanism spaces helps us understand the opportunities, and limits, of these spaces and the frustrations for activism in such spaces.

The third model looks at the efforts of the Obama Administration to integrate more direct citizen input into the process of policy determination, in contrast with the traditional offline ways in which influence is acquired and exercised on the Executive and Legislative Branches. The structure of the space where citizen input is made, and the manner of communication to the

³⁹ See generally The White House, <http://www.whitehouse.gov/> (last visited Oct. 26, 2009)

ONLINE INFLUENCE SPACES(S) AND DIGITAL INFLUENCE WAVES

citizens in that space, is a matter of seeing how a powerful institution like the executive branch can appropriate structures of online dialogue. This experience leaves us with the question of whether this type of access amounts to true access of the kind traditionally experienced in face-to-face meetings—the way digital immigrants were brought up to appreciate. It is possible, depending on the manner in which these comments flow up, what can occur is more “ersatz access,” in which citizens have the impression they have influence or impact, but the flow of information is from the central structuring entity to the citizen. How dissent in such a space amounts to meaningful dissent and influence is an unresolved aspect of this analysis.

Building on these three models, and focusing on the activism of any form plus technology dynamic, the next section attempts to imagine atomized citizens, and their means to use the online influence space in multiple ways. This effort shows how digital influence waves can be developed without central control through citizen efforts. The decentralized nature of the idea generation is a wave movement in itself. How that decentralized process intersects with real world institutions or aggregates in a manner that may be needed to exercise influence is another part of this reflection.

With the assistance of my co-author, we prepared schematics to demonstrate the kind of digital influence wave-formation possibilities and perils in the online influence space. Obviously, more work can be done on this subject matter. I hope that this paper will serve as a catalyst and integrator to push forward the reflection and discussion.

C. Case Study One: The Rise and Fall of American Society of International Law Resolutions

In January 2004, as a law professor and American citizen, I attempted to persuade those in power to criminally prosecute United States civilians and military generals in U.S. courts for torture, cruel, inhuman, and degrading treatment. My first “action” was standing outside a local community college during a presidential visit to Northwest Ohio with a small group of people holding a cardboard hand-scrawled sign and chanting, “Indict Bush War Crimes, Have a Nice Day.” In 2004, the focus of my compatriots was on jobs, not war crimes. I became involved in many traditional offline actions to influence: demonstrations, writing letters to Congresspeople, writing letters and op-eds for newspapers, speaking at conferences, and writing articles in law reviews.⁴⁰ Using my negotiation and persuasive writing skills, I

⁴⁰ See, e.g., Benjamin G. Davis, *Keeping Our Honor Clean: A Response to Professor Yoo*, 4 CHINESE J. OF INT’L L. 745 (2005).

encouraged others to focus on our common interests we had in seeking prosecutions. Other lawyers (and citizens in or outside institutions in the United States), did a multitude of actions, such as: defending detainees; pushing Congressional action; writing articles or reports; appearing in the media; and contacting colleagues abroad seeking to start prosecutions in foreign courts, such as Germany.⁴¹

In spring 2005, I went to my first meeting of the American Society of International Law (ASIL). The ASIL was founded by former Secretary of State Elihu Root in 1906.⁴² The ASIL is the premier international law society

⁴¹ For a non-exhaustive list of articles describing various works by me and others up until late 2008 see Benjamin G. Davis, *Refluat Stercus: A Citizen's View of Criminal Prosecution in U.S. Domestic Courts of High-Level U.S. Civilian Authority and Military Generals for Torture and Cruel, Inhuman or Degrading Treatment*, 23 ST. JOHN'S J. LEGAL COMMENT. 503, 644-46 n.275 (2008). Work continues by many on this subject including by the Human Rights Committee of the Society of American Law Teachers (www.saltlaw.org), AfterDowningStreet.org, the American Civil Liberties Union website, the Center for Constitutional Rights website, human rights organizations such as Amnesty International, Human Rights Watch, Human Rights USA, and the International Committee of the Red Cross. For a list of more recent developments see Benjamin Davis, <http://www.law.utoledo.edu/facultystaff/faculty/BDavis/BDavis.htm>.

⁴² See Benjamin G. Davis, *Semper Fidelis: Keep Our Honor Clean* (March 28, 2006), <http://www.law.utoledo.edu/facultystaff/faculty/BDavis/asil/SemperFidelisFinal.htm>.

As noted in the Milestones in the American Society of International Law's First Hundred Years (<http://www.asil.org/aboutasil/history.html>), the ASIL was founded as an outgrowth of the 19th century peace movement.

Initially, Elihu Root, a Nobel Peace Prize laureate and the first President, had two goals: scholarship to reveal and explain governing rules and principles of international law, and the effort to popularize international law so that an informed public could prod national leaders into settling international disputes by applying legal principles.

World War I jolted the ASIL's idealism and World War II slowed its momentum. At that time, in one of its few departures from a stance of public institutional neutrality, the ASIL adopted a resolution strongly favoring acceptance of the International Court of Justice "compulsory" jurisdiction and forcefully presented it to the Senate.

In the 1940's and 1950's ASIL changed slowly.

During national turmoil over Viet Nam, in the late 1960's and early 1970's, the ASIL provided a forum in which supporters and opponents of government policies argued the legal issues.

In the early 1990's the ASIL began developing Outreach programs in response to a Ford Foundation evaluation that gave ASIL high marks for meetings and

ONLINE INFLUENCE SPACES(S) AND DIGITAL INFLUENCE WAVES

in the United States and certainly one of the top institutions of its kind in the world. Domestic and foreign scholars, practitioners, international organization lawyers, and diplomats gather each year to reflect on a variety of topics related to international law.

I was impressed by two things at the annual meeting. First, within the American discussion of international law, there is a tension between those who place primacy on the United States constitutional framework in thinking about international law, and those who think in terms of international law as an obligation on states, regardless the internal constitutional structure. Those who focus on the United States constitutional structure see international law as it is projected through the Constitution as United States Foreign Relations Law. Thus, the separation of powers in the United States system becomes the most significant structural limitation on international law obligations internally in the United States. By contrast, those with the internationalist vision consider the separation of powers aspect of our Constitution an interesting aspect of how the United States addresses our obligations, but the international obligations (treaty or customary international law) are still the United States' burden. For this latter group, the question is how the United States, regardless of any constitutional specificities, brings itself into compliance with a given international law obligation.

Second, several of the speakers were members of the Bush Administration who had and were involved in crafting the torture policy of the Administration. From the floor, several of us questioned these lawyers for what they advocated. The answers were not satisfactory.

Later that year a colleague suggested I consider having the ASIL establish a resolution on torture. Here, I saw another path for activism. Successful efforts in 2006, and failed efforts in 2008 to pass resolutions on this topic are the subject of the remainder of this section.

publications but low marks for influencing public policy. Programs of regular briefings in Washington, Insight bulletins and the ASIL website were created.

Today, diversification within ASIL continues—not only do 40 per cent of the 4,000 members come from outside the United States, with nearly 100 countries, but women and persons of color have become more involved in ASIL leadership.

The Society's transformation—to serve members with greater electronic interactivity and to engage more non-international law policy actors—continues.

Id.

1. 2006 ASIL Resolution

To understand the dynamic of the online influence space, I think it useful to look at the structure for passing resolutions of the ASIL, as detailed in its constitution and the administrative guidance provided by the Executive Council. As overlay to formal procedures, one should remember that—unlike the time the governing documents were originally prepared—the ASIL later modernized its outreach efforts through the creation of an unmoderated listserv (comments were not screened before sent to the entire listserv membership) that was open to both members and non-members called “ASILForum.” In that forum I participated in discussions on issues related to international law and relations.

2. ASIL Constitution—Offline Space Vision in an Online Influence World

It is important to see how resolution consideration under the ASIL Constitution implicitly foresaw an offline process for resolution development and consideration. A brief look at the Article IX Resolutions of the ASIL Constitution highlights the envisioned offline process:

All resolutions relating to the principles of international law or to international relations, which should be offered at any meeting of the Society shall, in the discretion of the presiding officer, or on the demand of three members, be referred to the appropriate committee or the council and no vote shall be taken until a report shall have been made thereon. Resolutions may be submitted for consideration by the Executive Council in advance of any meeting of the Society by depositing them with the Executive Director not less than 15 days prior to the meeting.⁴³

What struck me was that the process envisioned a resolution proposal being made at a physical annual meeting (annual meeting route) first. In such a setting, a resolution faced three hurdles: 1) whether the presiding officer would use her power to allow the resolution to be presented at the same meeting as initiated, or refer it to the appropriate committee or the council; 2) whether three members would demand the resolution be referred to the appropriate committee or the council; and 3) the preparation of a report on the resolution.

⁴³ Constitution of the American Society of International Law (2007), <http://www.asil.org/files/ASILConstitution-Regulations.pdf>.

ONLINE INFLUENCE SPACES(S) AND DIGITAL INFLUENCE WAVES

The alternative path was to deposit a resolution a minimum of fifteen days before the annual meeting with the Executive Council—a group of persons elected under the control of the leadership of the organization.

The effect of the resolution process in an offline influence space discourages resolutions from anyone other than the most senior people in the field with the prestige to overcome: 1) presidential discretion; 2) other member tabling; and 3) report preparation delay. In such a setting, resolution development is distinctly top-down controlled structurally, with very little likelihood for lower level members to generate capture and control of this key power within the institution, without top-level assent or at least acquiescence.

This central control nature of the process regarding resolutions was reinforced in the Administrative Guidance provided by a 1966 Executive Council policy statement which states:

The Council in the future will recommend that the Society adopt resolutions urging action by persons outside the Society in only two types of circumstances: (i) Resolutions relating to technical matters primarily of professional interest to international lawyers and scholars. (ii) Resolutions relating to principles of international law or international relations, when all of the following conditions have been satisfied: (a) The matter is one which is generally considered by members of the Council to involve a matter of truly fundamental importance in promoting the establishment and maintenance of international relations on the basis of law and justice. (b) The matter is one in respect of which most members of the Society can reasonably be expected to be informed without the preparation of a special committee report. (c) There is no significant disagreement within the Society as to the desirability of the proposed action.⁴⁴

Subsection (i) encourages resolutions on technical matters, such as urging prompt publication by the United States of a history of United States Foreign Relations legal experience and key documents. Subsection (ii) places three restrictions on the development of resolutions of a broader scale. First, the proposed matter needs to be considered “fundamentally important” in promoting the establishment and maintenance of international relations on the basis of law and justice. Reasonable minds can disagree on the meaning and application of these terms. The opportunity for legitimate disagreement on the meaning of such words suggests that only the most anodyne resolution could pass such restrictions.

⁴⁴Davis, *supra* note 41.

Second, subsection (ii) focuses on the knowledge of a diverse group of scholars. In an environment of increasing specialization, a common basis of knowledge is daunting to assure on even the most basic of issues. The process of assuring oneself of common knowledge could be thwarted at the Executive Council level by the claim that individuals simply “did not know enough” to act on or speak about the merits of a given resolution.

Third, there is a need for “no significant disagreement.” Managing to achieve “no significant disagreement” among members of an august group, some of whom participated in the formulation of the policy at issue, posed a third peril for a resolution.

In combination, just like the formal process rules of Article IX of the Constitution, the more substantive standards provided in the Policy Statement of the Executive Council presented a distinct challenge to a low-level member who, seized by passion, sought to exercise membership rights to have their institution take a position regarding an urgent issue of the day.

3. Online Influence Spaces and Digital Influence Waves: Reinventing the Offline Structured Process

However, it became apparent that formal and substantive hurdles created in the context of an offline influence space dynamic for resolution approval did not capture the opportunities of online influence spaces and digital influence waves to substantially modify the process of resolution formation and adoption.

First, the ASILForum became a virtual, ongoing meeting not tied to space, time, or location. By inserting oneself into that space, with the intent to have a collaborative drafting and adoption of a draft resolution through elaboration, debate, and consensus building, created the possibility for building acceptance for a resolution over months—not hours. Thus, a three-step process developed in which: (1) a preliminary draft was presented for comment on the ASILForum; (2) the preliminary draft was followed by an amended draft; and (3) finally, a second amended draft.⁴⁵ The collaborative process of commenting and fine-tuning occurred not only in the ASILForum space, but also in e-mail exchanges to supplement the forum discussion. This combination of discussions led to a vivid discourse at a high level regarding the merits of each aspect of the draft resolution. The final effect, once consensus occurred on the final draft, was that far more than the required three members signed the draft when it was submitted to the ASIL leadership two months before the annual meeting. In addition, each individual on the

⁴⁵ *Id.*

ONLINE INFLUENCE SPACES(S) AND DIGITAL INFLUENCE WAVES

ASILForum—both ASIL and non-ASIL members—had the opportunity to transmit the listserv discussions to other interested persons in their personal or institutional networks. These outside discussions influenced the ASILForum in turn, and through informal contacts, ASIL leadership. A further aspect of this online process was that the influence of active members at the center of the discussion was extended to inactive persons (lurkers). In the process of reading discussions, unstated questions and concerns were discussed at length—helping build consensus about the wisdom of an ASIL resolution. We must also remember that the online discussion happened two months before the annual meeting in physical space.

Subsequent to the submission of the draft resolution to the ASIL leadership, the presence of a draft resolution online provided opportunities for those attending the annual meeting to reflect on the proposal's merits. Again, personal and institutional networks' discussion of questions, concerns and enthusiasms evolved without concern for space, time, or location. Lurkers could turn into active resolution evaluators, seeking modifications of the draft to reflect their concerns. Other ASILForum members could compare the concerns of lurkers with the draft resolution to determine whether such modifications were warranted. With each analysis without further modification, the solidity of the draft resolution increased and further members signed on to its adoption. This consensus building process occurred far afield of the physical meeting on March 29–30, 2006.

As the draft resolution solidified, the problem for those heading the ASIL created an asymmetric dilemma. The resolution “gained steam” and was bottom-up, member generated, while the structure of the ASIL sought to provide top-down control. As such, the resolution was perceived as a threat to the hierarchical vision of the ASIL and its “workings.” In fact, the resolution implicitly critiqued some of the work by high-level members of the ASIL—personally embarrassing these members. On the institutional level, the problem was how the ASIL leadership, committed to international law, could block the adoption of a resolution reminding the United States of basic international law rules regarding war and detainee treatment. Whatever the reason for blocking the resolution, it would be perceived as the ASIL deviating from stated ideals.

From the individual member's perspective, based on the infrequency of resolution adoption, the likelihood of success for any resolution made it a “win-win” situation. If the resolution was adopted, it would reaffirm the key principles of the resolution. If the resolution was not adopted, then the low-level members “did their best.” This asymmetry in the perception of the ASIL resolution process was permitted by the exploitation of the online influence space that destabilized the institutional hierarchy.

The ASIL institutional hierarchy, however, was in a position of power. Shortly before the fifteen day deadline for submitting resolutions for the annual meeting, two significant things happened. First, the Executive Committee met and “crossed the Rubicon,” concluding that a resolution was imminent. Second, an effort was made to write a resolution that was not United States-focused, but was a passive, universal-focused statement. The effect of the second resolution would have diluted the impact within the United States and made the resolution less controversial.

Aiding the resolution dilution process, senior members of the organization contacted the low-level members, congratulating them on their success in drafting the resolution. The senior members also pressed for consensus on the universal version. In offline influence space, this pressure would occur during the annual meeting, either leading to the weaker version being accepted, or the whole resolution considered “too controversial” and nothing adopted—consistent with the limited adoption practice in the past.

However, the senior members' strategy did not take into account the online influence space and digital influence wave dynamics. Posting the amended universal draft in the ASILForum, along with a harsh critique—supported by other members' critiques—created transparency. For the author of the universal version, there was a risk of loss of face by the unfiltered online open critique. Moreover, while the typical offline phone calling and arm-twisting could occur (and did), the reality was that the online space—having gained ownership of the original resolution—reacted forcefully against the second, weaker resolution.

The consequence of this tension was the threat of a crisis at the Executive Council meeting at the annual meeting. As in all negotiations, persons with ties to the member-generated resolution and to the leadership proposed a third resolution. Although universal like the second version, it used stronger language than the original universal draft and pushed toward the critique in the online developed draft resolution. Again, placing the third option in the ASILforum provided for immediate and rapid debate in the few days before the annual meeting where the third resolution version was dissected and evaluated.

The net effect was that highly ranked ASIL members committed to passing a resolution. Then the question became: “which version?” Debates were extensive in the Executive Council session, but several prestigious members insisted a resolution be passed. Over time, a consensus emerged to complete a resolution (backed by the Executive Committee), and debate settled on whether to adopt the America-focused or the stronger, universally focused versions. Ultimately, the Executive Council adopted the strong, universally-focused resolution—while a defeat for the creators of the

ONLINE INFLUENCE SPACES(S) AND DIGITAL INFLUENCE WAVES

American focused version, the resolution was nevertheless a significant achievement given the paucity of successful resolutions of the organization in the past.

With the Executive Council imprimatur, the recommended draft resolution was posted on the website, and diffused at the annual meeting the next day for adoption, arriving at the offline space dynamic originally envisioned by the ASIL Constitution. However, the online influence space, consensus-building and momentum for the resolution were already significantly advanced. Distinguished ASIL Presidents and members spoke in favor of the resolution, staking their reputations on the resolution. An international dynamic led to the resolution's adoption when a scholar stated that he considered the resolution, "garden variety international law" and asked whether any of his foreign colleagues objected to the resolution. In a room full of the largest number of attendees in ASIL history, there was silence. The renowned scholar then turned to his American colleagues and asked if they possessed any quarrel with the resolution as a statement of international law. Again, the room was silent. From that silence, consensus on the resolution was created.

A rearguard (or strategic) step occurred with a proposal from the floor to add a sentence to the resolution regarding the United States. Those members uncomfortable with the proposal had an opportunity to vote on the America-specific amendment, which was defeated. This vote paved the way for the adoption of the strong, universal version on a very difficult subject.

4. Institutional Hierarchy Strikes Back

There was, however, a cost to the 2006 ASIL resolution. The ASIL hierarchy, concerned with how the rules worked in the initiation of the resolution, made two determinations. First, they shut down the ASILForum, turning it into a members-only forum with formal control. Second, they created a committee to examine the resolution initiation process, and formally introduced a review of proposed resolutions for "conformity" by the Executive Committee. While ostensibly only a formal compliance review, the definition of what is "form" or "substance" leaves a space for discretion to prevent the submission of a draft resolution to the Executive Council—a space that had not been there in the Constitution and prior Policy Statement. Third, in addition to forging a consensus, members would have to draft a non-controversial statement in the period prior to submission of the draft. This statement required a detailed report *ex ante*, a report that was usually created *post hoc*. Resolution and consensus on a draft statement would be cumbersome to achieve. These changes dissuaded further resolutions by

formally centralizing control of resolution submission and raising the hurdles to submission. Thus, a further resolution on a similar topic on torture was introduced in 2008 through an online process similar to 2006. However, unlike the 2006 resolution, the 2008 resolution did not leave the Executive Committee and was not considered at the subsequent annual meeting.

5. Listserv Space More Schematically—Movement and Institution

For any readers who are unfamiliar with a listserv, Appendix A provides an example of a discussion on the ASIL Forum listserv.

Illustration 1, below, provides a theoretical schematic of a listserv. Individuals join the listserv. They may participate in a range of ways, including passively observing discussion (lurkers), to commenting on all developing discussion threads. In an unmoderated listserv, any comment by a member of the listserv is sent to all members. In more moderated settings, an administrator or owner of the listserv has to approve each comment sent to the members, filtering comments through the administrator's preferences. Thus, in the more moderated settings, there is a feedback loop between the administrator and the initiator of the comment that can be: simple (administrator admits all comments); or more complex (discussions with the initiator of whether the comment is germane). In all of these moderated or unmoderated settings, the administrator retains power to exclude people from the list, and possibly to delete comments. However, in an unmoderated setting, deletion power is moot because the deletion occurs after the initiator sent the comment to the listserv.

ONLINE INFLUENCE SPACES(S) AND DIGITAL INFLUENCE WAVES

Illustration 1. Schematic of a Listserv.

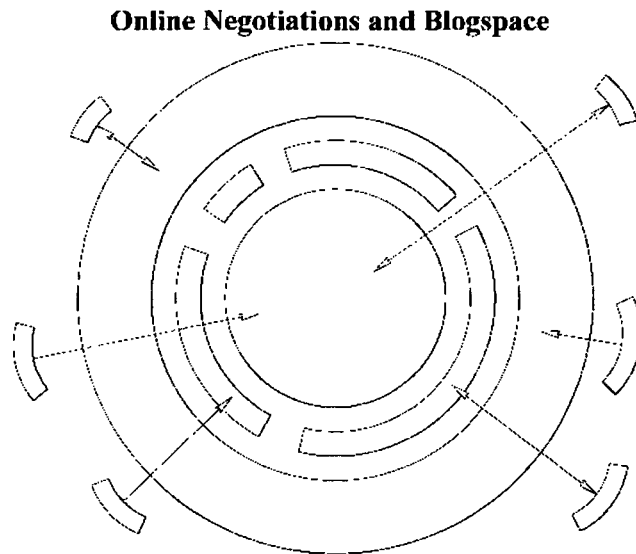

Moving from the theoretical schematic vision of the listserv space, Illustration 2 provides a better picture of the dynamic in an unmoderated listserv, such as the ASIL Forum. This schematic introduces the listserv as an amphitheater of chairs. The center of the amphitheater are the most active members who introduce ideas for discussion. As one moves outward through successive rings, the frequency of action in discussion declines. The result is that the outer rims are “pure lurkers” who only observe discussions. For each topic discussed, the individuals at the center of the listserv may change (in analogous physical space, those sitting at the center table shift), and those in successive rings that flow out change regarding who is an active participant, or passive observer. Persons flow into the listserv space by joining—bringing with them ideas and perspectives they seek to emphasize (A, B, F, G, H, and I in Illustration 2) or leave for lack of interest or other reasons (C, D, and E in Illustration 2).

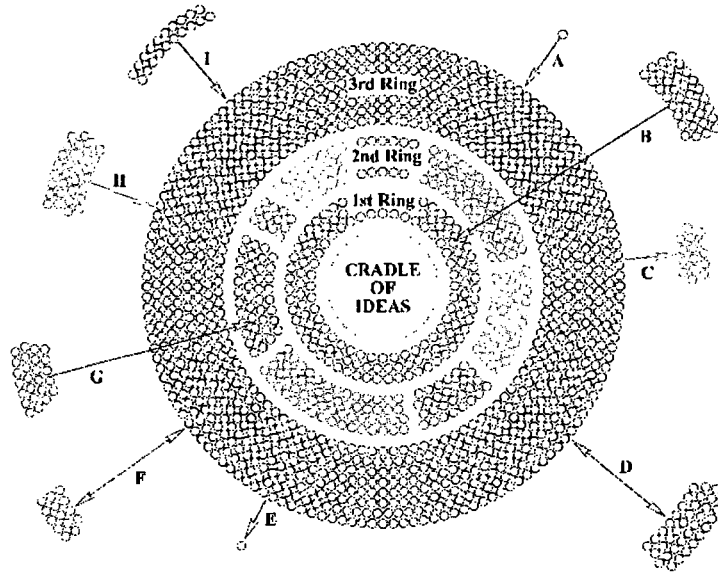
Illustration 2. Cradle of Ideas

The unmoderated nature of an online space makes it possible that, based on the idea; members will have rapidly changing positions in a given period. Different people may lead on different topics. Ideas can step on other ideas in a situation that appears to approach cacophony.

Yet, as seen in the ASILForum space, this online space, like all human endeavors, has the possibility of self-ordering. In the ASILForum, a steady effort by individuals sitting at the center table shepherded the resolution through the space diminished the willingness of others to interject non-germane comments. The net effect turned an unmoderated space into a collaborative workspace through self-ordering of the space membership. Once a cohesive moment arose, then the distributed knowledge of all the members contributed to clarify and enhance the nature of the idea forwarded. This dynamic is why I call this schematic "the cradle of ideas."

It is important to understand that the reasons for any initiator placing an idea in this cradle of ideas are as complex as human nature. They come from the person's experience and view of themselves, both in their role as a list-member and in the political frame as a citizen. However, once that person emits the idea, the indifference to space, time, and location of the listserv permits other members to show affinity for the general nature of the idea and

ONLINE INFLUENCE SPACES(S) AND DIGITAL INFLUENCE WAVES

turn it from nascent form into an idea “whose time has come” (or Alberoni’s nascent state).⁴⁶ This second aspect of the cradle of ideas is the beginning of the movement (borrowing from Alberoni) around the idea—as seen in the movement for the ASIL Centennial Resolution on Laws of War and Detainee Treatment. The online influence space’s indifference to space, time, and location lowers the barriers for movements to emerge and permits the acceleration of refining the idea. With each person refining, ownership of the idea devolves such that each participant hardens the power of the idea.

However, each participant in the listserv space is not solitary. They have in combination ties to members of the organization and others with access to power in society—or may be powerful in their own right. Each person has an influence role peculiar to his own history and status. In the listserv dynamic, influence is represented by the network of contacts they have. Illustration 3 is a schematic of a listserv influence dynamic with each of the curved blocks representing the networks that one person in a chair in the cradle of ideas of Illustration 2 might influence.

Illustration 3. Schematic of a Listserv Influence Dynamic

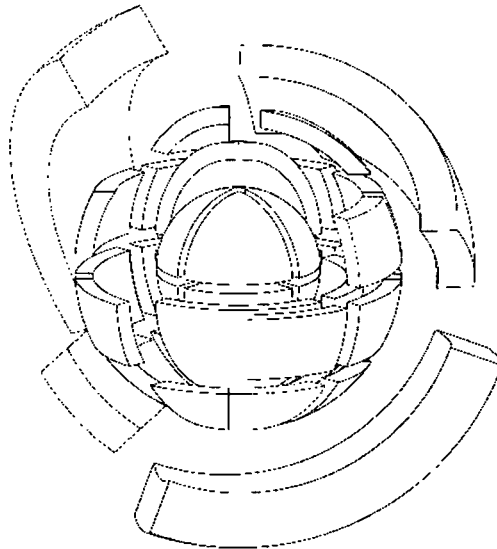

⁴⁶ ALBERONI, MOVEMENT AND INSTITUTION, *supra* note 3, at 34–167.

The layering of personal influence networks on top of each other is a crude but effective way of understanding how the center of the cradle of ideas operates within their influence networks both within and outside the listserv. Consider that those at the periphery of the cradle may be influenced by listserv discussion and are lurkers in listserv space, but may be influential persons. As the listserv discussions harden the nascent idea into a movement, the movement reaches everyone in the personal influence spaces of listserv members and the movement aggregates into an active, emerging power.

The personal influence networks of any member of the listserv are not limited to that listserv, or to the online environment. These persons also have power and influence in the offline physical space. Thus, an idea flows from the cradle of ideas in one listserv, through the personal influence spaces of members, to other offline and online influence settings. This intra-listserv, inter-online, and offline-online flow is the entire digital influence wave for an idea. The power of the wave is related to the power of the idea, the power of the individuals who own the idea, and the degree to which those individuals have personal influence networks that have access to power.

In this vision, one can understand the power of the ASILForum. Many members were influential individual with large influence networks that they accessed as they took ownership of the resolution idea. The resolution digital influence wave, grown from the bottom-up, reached tsunamic proportions inside the ASILforum. Imagine being at the top of the ASIL and having to cope with an ideological development outside the hierarchical processes formally created.

The reaction of the institution to an idea allowing the idea to flow, trying to channel an idea, and ultimately finding compromise that melded the top-down and bottom-up approaches, is the bright side of the online influence space and digital influence wave dynamic (Alberoni's institutionalization of the movement—movement that developed from a nascent state). The hierarchy also learned the inadequacy of offline physical space structures when trying to channel ideas and maintain hierarchical control. The ASIL hierarchy's reaction was clear. First, closing down the ASILForum as a non-member forum, and turning it into a member forum was an attempt to remove the personal influence spaces of non-members. The hierarchy tried to split the personal influence spaces among those who had some attachment to the ASIL hierarchy through membership.

Illustration 4 demonstrates the effect of cutting out non-members from the ASILforum—essentially cutting away the people with access to the cradle of ideas and removing them from the idea.

ONLINE INFLUENCE SPACES(S) AND DIGITAL INFLUENCE WAVES

Illustration 4. Splitting the Listserv Dynamic

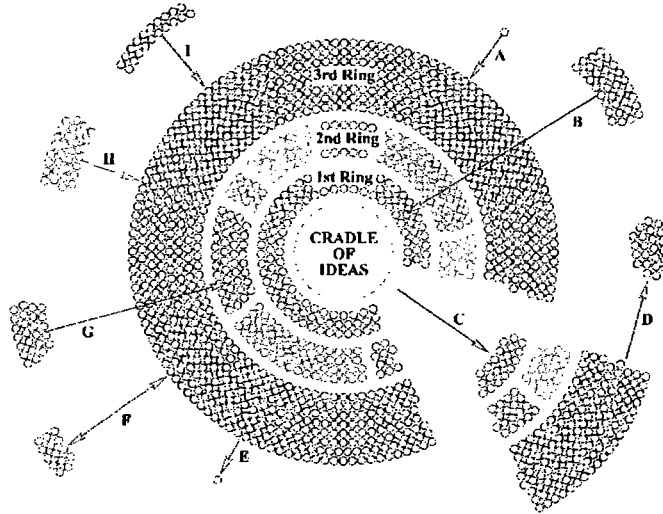
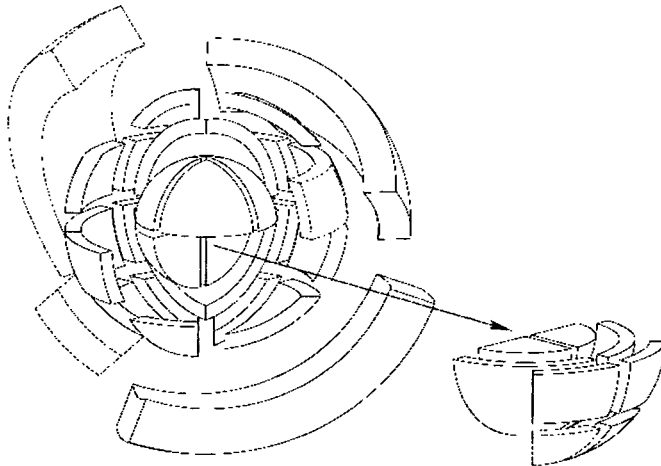

Illustration 5 shows the concomitant effect of the cutting out of the non-members; their personal influence networks are not readily accessible regarding the nascent idea.

Illustration 5. Splitting of a Listserv Personal Influence Dynamic



The effect of the decision to become a members-only forum is the reduction of the potential power of ASILForum space and enhanced the central control on the resolution development. Adding to the 2008 requirement of an ex ante report and formal Executive Committee approval for a resolution to advance, one sees that the free-wheeling possibilities of the original listserv were domesticated by a system of control in 2008. Within the domesticated ASILforum, can this process occur again? It is possible; however, the structure has been recreated (considering current technologies) in a manner that assures significant central control of the resolution development process.

This process illustrates the development of hidden hierarchy in an otherwise free-wheeling online environment. The formal structural decisions made by the central hierarchy have an effect on how the online influence space will prosper and how digital influence waves flourish.

The next case in blogspace furthers this analysis of structured space, movement and institution, and hidden hierarchy.

D. Case Study Two—Blogspace & The Volokh Conspiracy

For those not familiar with a blog, I encourage visiting the Volokh Conspiracy⁴⁷ to see the structure of a blog. A page taken from the Volokh Conspiracy appears below as Illustration 6.

⁴⁷ The Volokh Conspiracy Main Page, <http://www.volokh.com> (last visited Oct. 26 2009)

Illustration 6. Example of a Blog—The Volokh Conspiracy



Friday, February 6, 2009

[Jonathan Adler, February 6, 2009 at 1:27pm] Trackbacks
Could the Stimulus Start a Trade War?

Some commentators and trade experts have expressed concern that the "Buy American" provisions in the stimulus are not only wasteful, but potentially harmful in that they could be a prelude to greater protectionism, both here and abroad. For instance, last Saturday in the *NYT*, Douglas Irwin wrote:

Steel industry lobbyists seem to have persuaded the House to insert a "Buy American" provision in the stimulus bill it passed last week.

...

The Senate's "Buy American" provisions are even worse, and could have significant trade implications while providing minimal offsetting employment benefits, noted trade economists warn. Pascal Lamy, head of the World Trade Organization, has also expressed concern.

....

Should we be worried? Daniel Drezner tries to inject a dose of optimism. I hope he's right.

8 Comments

In case two, a person trying to initiate an idea might participate in a blog such as the Volokh Conspiracy as above. Similar to the cradle of ideas, above, the personal influence networks, blogs, and their following have

effects in engendering digital influence waves. Blogs are accessible on the web while listservs are open only to their members. Thus, anyone may discover a blog, while one has to become aware of a listserv and actively join.

At the same time, the blog dynamic is significantly different from the listserv. First, in the unmoderated listserv, any member can be at the center of the cradle of ideas by initiating an idea. The power to initiate a discussion is centralized in the blog owner in blogspace. The owner and the individuals who can initiate discussion and make comments in a blog is the hidden hierarchy of a blog. The selection of official leaders and guests are subject to offline and online dynamics filtered by the blog owner. Thus, the cradle of ideas initiation is skewed by this first hurdle to accessing online influence space. If the blog does not initiate comments on a topic an individual wishes to discuss, other than attempting to guest initiate, or being accepted by the owner, an individual can only divert comments on a topic to her idea.

In addition, the nature of the comment threads on blogs, organized by an initiating comment with occasional links to related discussions, as determined by the blog owner, is serial. Rather than a collaborative dynamic there are a number of comments that proceed seriatim. The process of conducting a discussion on a topic—the collaborative moment for the nascent idea—is difficult due to the requirement of pasting the relevant prior comment in one's own comment to create a pseudo-thread in the midst of other contributions.

More schematically, this central control and threading is presented in Illustration 7, below. The central ball is the center of ideas and balls around the central ball are the designated initiators and owners of ideas for discussion. The outermost balls represent individuals who become part of the blog. They can initiate comments once permitted by the blog owners (arrow to balls rotating the center of ideas) or they may make comments on a given topic (the smallest balls flowing down in strands from the owner balls).

Illustration 7. Blogspace Schematic

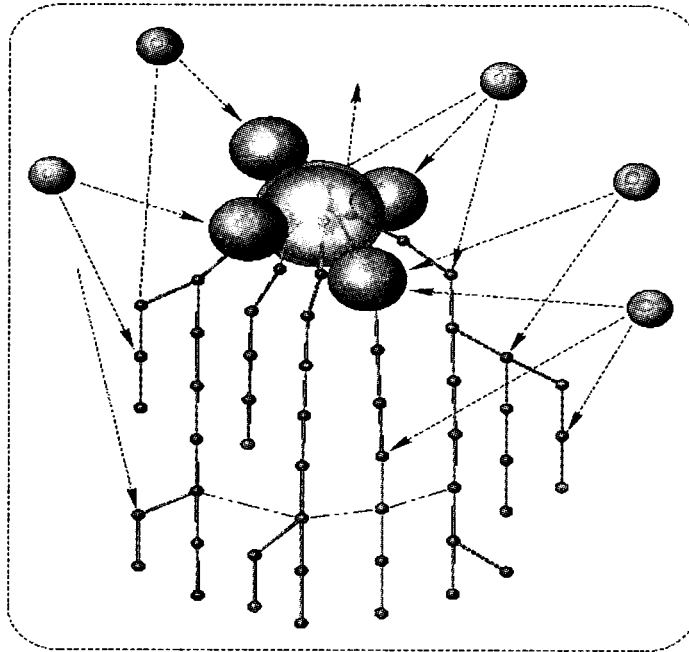

The complexity created by the blogspace schematic is that the discussion topic initiation is controlled and the comments are linear such that there is difficulty in creating sufficient space for an idea to blossom into something more than discussion—similar to the ASILForum listserv. The blogspace structure places the non-owner participant in responsive position. Now, personal influence networks of participants may be significant, but the building process of the nascent idea is subject to non-negligible hurdles—making the blog dynamic a diffuse “comment” space rather than “action toward movement” space. We might say that the blog is an intermediary position between listserv and the printed press. While blog editors are masters of their online domain and have the initiative on selecting topics, the press owners contend with institutional culture in physical space that affects their approach to such spaces. Yet, in both case of blog or online print press, lines of comment that arise under the initial article are less action space.

However, the structured space of one blog is not the structured space of all blogs. To the extent individuals can find blogs relevant for a particular idea, they can create a dynamic in the comments of those blogs to create or sustain a nascent idea. Thus, regularly commenting in several relevant blogs

can have the effect of creating a more diffuse cradle of ideas and; in turn, the possibility of personal influence waves creating digital influence waves. Illustration 8 is an example of how a person regularly visiting three blogs and commenting on international law creates a cradle of ideas and digital influence spaces, building personal influence networks to create digital influence waves. Whether the openness of access to blogspaces countervails the controls on each blog and the diffuse impact of the comments space in a manner that leads to the nascent idea developing, similar to the described 2006 ASILForum is beyond the purview of this paper. I attempt to highlight that dynamics may be ways to counteract the power of the blog's hidden hierarchy that may lead to a nascent idea and movement arising.

Illustration 8. Comments Across Blogs Online Influence

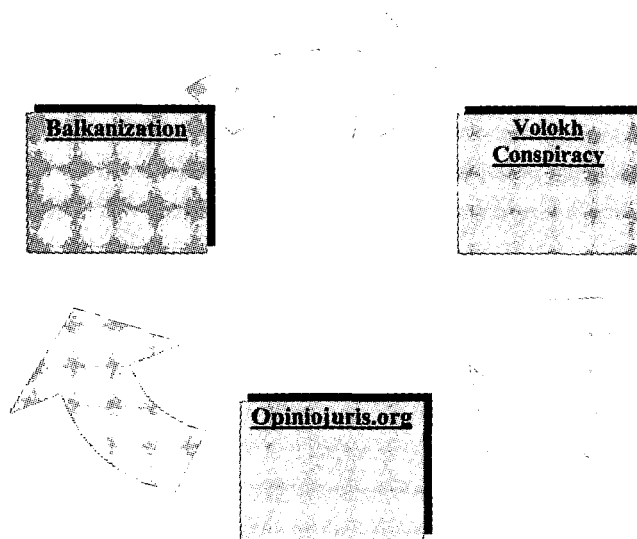

It should be noted that offline institutions may create their own blogs and overtime, these blogs become institutions with their own codes regarding what is acceptable on their site. One of the most interesting developments on blogs has been when topic initiators do “not turn on comments.”⁴⁸ Thus, a topic is not started as a basis for comment, but for the owner to forward an idea that cannot be challenged in the blog space. This type of development is

⁴⁸ The term “not turn on comments” means that the topic initiator on the blog does not open the topic to permit the reader comments. The reader made a passive receiver of the topic, rather than an active reader and commentator.

ONLINE INFLUENCE SPACES(S) AND DIGITAL INFLUENCE WAVES

a severe example of hidden hierarchy and central control of an online influence space. While the power of the initiator may turn an idea into the start of a movement, this dynamic resembles the offline setting in which power-holding individuals dictate the terms of the debate in a top-down mode rather than the collaborative dynamic described in the 2006 ASILlistserv resolution process.

E. Case Study Three—Obama Open Governance Project

A third vision of online influence space has been initiated by the Obama Administration in its “Open Government Project.” While said project has numerous aspects, my interest lies with the three-phase process for citizens to craft recommendations regarding open government. A schematic of that process is presented in Illustration 9, below.

Illustration 9. Obama Open Governance Project

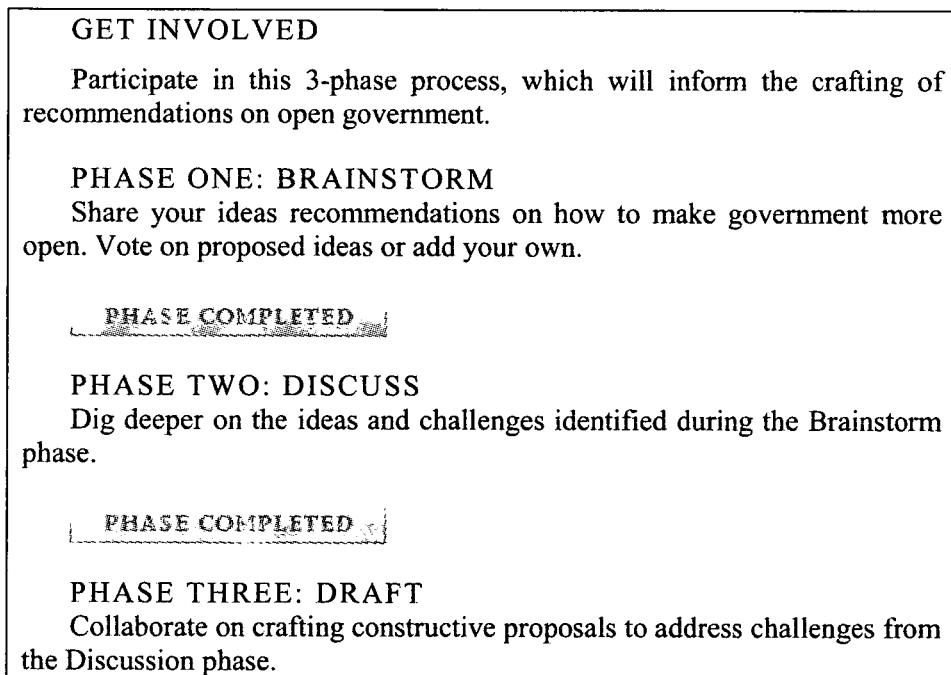

Once citizens introduced ideas, voting on ideas was permitted (Illustration 10, below). Some weight might be attached to an idea that received more votes, but it is unclear what that weighing of votes should be.

Having participated in efforts to garner votes for a specific topic, votes may gauge the ability of the individual behind the idea to gather support. Put another way, the votes evaluate the personal influence network of the idea initiator. Of course, the voting does not indicate who voted. An idea with few votes, all of them from chairs of Fortune 500 companies, might have extremely significant power, but that power is masked in the online representation of the idea.

Illustration 10. Open Government Dialogue Voting Example



👍 Looks Promising!
894

👎 I'm Not So Sure . . .

End Imperial Presidency
By david 29 days ago

Leave the White House less imperial than you found it. Appoint an independent prosecutor to prosecute Bush, Cheney, and their top officials in order to deter in the future the crimes of aggressive war...

We, the people, must:

Demand that Congress ban the use of funds for any activities created in violation of the law by presidential signing statements.

...

OPTIONAL PART 2 OF THIS PROPOSAL -
Drafted and withheld at first, posted May 29th in response to useful comments from ttahiti and many others posted below.

Release more evidence, and support organizations suing in court for the release of evidence.

...

Comments (231)

ONLINE INFLUENCE SPACES(S) AND DIGITAL INFLUENCE WAVES

Tags: Legal & Policy Challenges, power, rule of law, constitution

We can see this development as creation of a formally structured online influence space with direct access to the Executive Branch. In the ASILForum listserv and the Volokh Conspiracy blog, access to influence of the idea is through membership of the powerful, or carried by someone of power through personal influence networks to create the digital influence wave. In contrast, the citizen in this space the citizen has the appearance of direct access to the levers of power and the idea can first become nascent, then become a movement within the institution, and finally change the institution in a free-flowing dynamic not possible offline (through traditional means, i.e., meetings, lobbying, etc.).

However, the structure of the Open Government space is similar to a blog, with the exception that the blog owner does not control the initiator of an idea. The comment thread from an idea on the Open Government space recalls the comment threads on a blog discussed in Illustration 7, above. Also, it is possible to create cross-blog (either within the Open Government space, or across outside blogspaces) dynamic for an idea similar to the type described in Illustration 8, enhancing the power of an idea, and sparking a movement. At the same time, whether the diffuseness of the Open Government space results in the creation of powerful digital influence waves is difficult to perceive.

One difficulty in the Open Government space is that it is hard to perceive the flow from this space to the levers of power. If the personal influence networks of the creators of the Open Government space are inside the hierarchy, then a new means for a nascent idea to become a movement was developed that offsets traditional means of influence in the physical space. If, however, the individuals who created the Open Government space are not individuals with influence, the effort therefore provides a false consciousness of access—an ersatz access that feels like access to power, but is not.

Structurally, the categorization of the space remains centrally controlled, so an idea can be highlighted through the creation of specific categories, or the idea can be buried with other ideas in a vague category like, “other issues.” For example, the “Imperial Presidency” is not a separate category, but can be found in an “other issues”-type space. The power to structure a free-flowing idea space is power to channel the cradle of ideas—either enhancing or reducing the barriers of access to the idea. Filtering interest in a topic through title organization, encourages viewing the ideas based on the location of the title. Finally, the flow-up of ideas also permits disseminating ideas downward from the center. Thus, rather than a bottom-up structure, the

Open Government space is a two-way system where ideas can flow out from the center of power to members of the space, asserting broad influence upon individuals who demonstrated their a propensity toward activism through posting in the Open Government space. The duality of the Open Government space may be masked, but it should be pondered as we evaluate these efforts in the future. An illustration of this dual dynamic is in Illustration 10.

Illustration 11. Next Level Online Influence Schematic

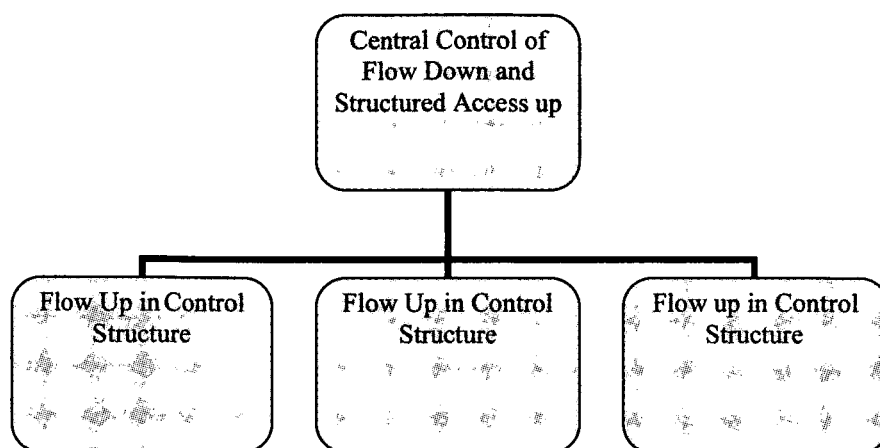

F. Summary of the Case Studies

We have endeavored, through discussion of these case studies, to reflect on the concept of online influence spaces and digital influence waves. In the unmoderated listserv space, I presented basic schematics of the concept by representing the cradle of ideas as an online influence space not subject to constraints of space, time, or location. In addition, I pointed out the listserv's intersection with the personal influence networks of the individuals involved. Together, the cradle of ideas and personal influence networks form the digital influence wave. The potency of a wave is dependent on the quality of the idea and the significance of the personal influence networks involved. Potency may determine whether a wave turns into a movement—born online as opposed to offline space—that impacts and changes institutions.

Institutional response to free-flowing online influence spaces was demonstrated. Hierarchy has power and demonstrated its ability to harness the cradle of ideas and, therefore, channel the flow of a digital influence wave. Put another way, hierarchy turns the spigot on the ideas. Some hierarchical controls, hidden hierarchies, were described, particularly in the

ONLINE INFLUENCE SPACES(S) AND DIGITAL INFLUENCE WAVES

context of blogspace and the Obama Administration's Open Government space. The centralized control mechanism in a simultaneous up and down dynamic was noted in the Open Government space, but it was also cautioned that access may be ersatz access instead of direct access from the center to the citizen and influencing the citizen's comportment with the administration.

It is important to remember that online influence spaces and digital influence waves have counterparts in the offline world. Conferences, annual meetings, etc.—the offline spaces where deliberation occurs—are influence spaces where personal influence networks can create an idea that sparks a movement. With all of the technologies that permeate offline spaces (teleconference, videoconference, etc.) the blurring between traditional offline space dynamic and online space dynamic is apparent. Possibly the best way to think of this is to think in terms of degrees of technological mediation of the influence space (offline and online) and influence wave (offline and online).

What is important for lawyers and law students to understand is that these dynamics have a sustained presence in our existence—they are part of the new reality in the digital age. As real parts of the physical and virtual landscape, it may behoove lawyers to contemplate how they may exercise their roles of influence in negotiation and mediation in a manner that successfully takes advantage of the opportunities while being sensitive to the perils of these digital environments.

III. AND WHAT OF THE POOR CITIZEN—ATOMIZATION—CITIZEN-LAWYER MANAGING ONLINE INFLUENCE SPACES

In this last section, building on our discussion above, I seek to ponder in meta-form the technological mediation that is going on in influence spaces. The depressive overload, leading to the emergence of an idea to restructure society in the form of a nascent state, affinity between persons creating a movement, the movement coming into contact with institutions and the reaction or change dynamic of Alberoni's brilliant sociological vision suggest a few pathways for reflection on this topic.

The citizen who, for personal reasons, is seized by an idea and seeks to influence others with the idea has a task that appears to be getting more complex while free from the space, time and location constraints of offline space. What I mean is that the evolution of technology provides more types of spaces in which the citizen may seek to put forward their ideas. At the same time, this sheer development of methods of presenting an idea also seems to engender institutional reaction to try to channel those spaces in a

manner that neutralizes them. Neutralization can come in the form of the sheer volume of similar sites that make no one site a powerful center, through the control of who gets access and who can speak in the site, or through a number of other mechanisms.

But, and here I differ strongly with Cass Sunstein, the overwhelming wave of these developments and the need for filtering by the citizen in order to cope are not necessarily paths to inert people or apathy. Rather, apathy is a choice that a citizen makes—it is not the technology that leads one there but the combination of influence that makes one feel it is better to be inactive and acquiescent to what is around (push forward or give up on the nascent state in a formulation that might be made by Alberoni).

If, for the personal reasons only known to a individual, the need to create an idea and assert it for purposes of influence grows for reasons that may have more to do with psychology than law, it seems that each of these evolutions of the digital environment is not an obstacle but rather a means to be evaluated for starting the cradle of ideas, building the online influence space, and using the personal influence networks to create the digital influence waves that form the birth of the nascent idea into a movement that leads to change or adaptation of institutions—whether public or private.

Illustration 12 tries to articulate the ability to influence back even in an atomized setting. The lawyer at the center acts in offline space on persons of influence (persons 1 and 2—for example a judge or an official), in blogspace (*Volokh Conspiracy*), and all the other myriad technology spaces (other bubbles). In this atomized vision, what the lawyer is doing is creating a cradle of ideas of the kind discussed in the ASILForum listserv, but one that does not have a sense of being a specific space seen by all who are members and is a more diffuse cradle of ideas space that still may have potency. From that cradle of ideas, the dynamic that leads to movement and institutional change described above is made possible. Obviously, the paths to such a role by a lawyer are not clearly articulated here. Rather, what has been presented is an inkling of what such a cradle of ideas in online influence spaces would look like as a meta-cradle of ideas. Concomitant with such a meta-cradle of ideas, one can see how the emanations from such a cradle can lead to more meta-digital influence waves (meta in the sense of behind what we see) with potency of a kind that may be significant, or, at least, non-negligible.

ONLINE INFLUENCE SPACES(S) AND DIGITAL INFLUENCE WAVES

Illustration 12. Atomization as Power

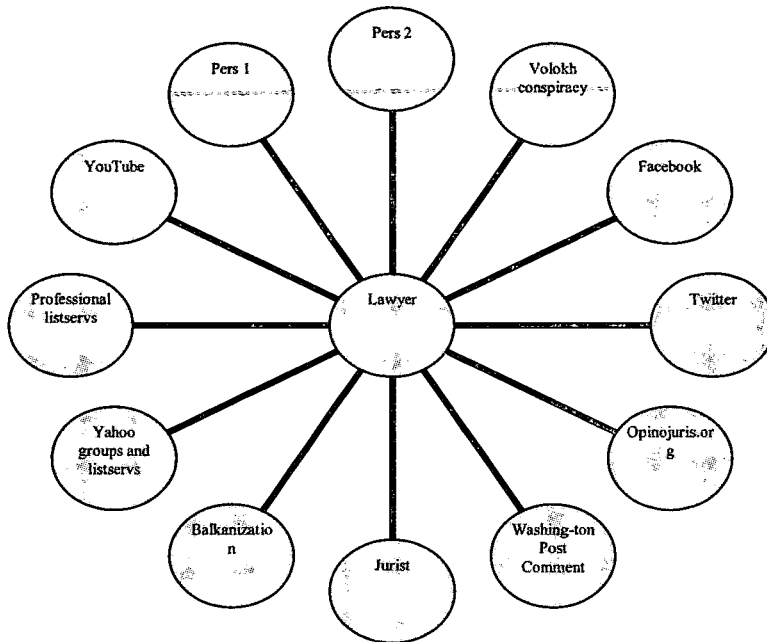

IV. CONCLUSION

In February 2009, both chairs of the House and Senate Judiciary Committees called for investigation and criminal prosecutions of high-level civilians for torture.⁴⁹ The President of the United States ordered the closing of Guantanamo and restricted interrogation techniques.⁵⁰

⁴⁹ See Rep. John Conyers, *Our Responsibility*, HUFFINGTON POST, Jan. 31, 2009, http://www.huffingtonpost.com/john-conyers/our-responsibility_b_162704.html; HOUSE COMMITTEE ON THE JUDICIARY, REINING IN THE IMPERIAL PRESIDENCY, LESSONS AND RECOMMENDATIONS RELATING TO THE PRESIDENCY OF GEORGE W. BUSH 175–76 (2009), available at <http://judiciary.house.gov/hearings/printers/110th/IPres090113.pdf>; Kate Phillips, *Judiciary Chairman Calls for Commission to Delve into Bush Practices*, Feb. 9, 2009, <http://thecaucus.blogs.nytimes.com/2009/02/09/judiciary-chairman-calls-for-commission-to-delve-into-bush-practices/?scp=1&sq=Patrick%20Leahy%20torture&st=cse>.

⁵⁰ See Whitehouse.gov, President Obama signs Executive Orders on Detention and Interrogation Policy (Jan. 22, 2009), http://www.whitehouse.gov/the_press_office/BACKGROUNDPresidentObamasignsExecutiveOrderonDetentionandInterrogationPolicy/.

Between waking up one morning and taking my shower, I checked my Blackberry and saw a petition effort to speak out on the treatment of African-American children at a suburban private club's pool.⁵¹ I signed the petition and within minutes, received a note both thanking me and providing a draft letter to forward to my friends, spreading information about the petition. Later that day, I sent my friends the requested note. The point of this anecdote is that the person at the idea's center wanted to engender a wave, and my response was one drop in that wave. Whether the numbers were great such that the wave grew from a ripple, to white caps, to tsunami is not known at this time.. However, even digital immigrants can participate in this digital influence wave formation and expansion, providing possibilities for influence previously unimagined. It is about this space that we need to teach our students as they examine the levers of influence they can pull for either their clients or causes.

⁵¹ See Zoe Tillman & Max Stendahl, *Montco Swim Club Accused of Racial Discrimination*, PHILADELPHIA INQUIRER, July 9, 2009, available at http://www.philly.com/philly/news/local/20090709_Montco_swim_club_accused_of_racial_discrimination.html.

ONLINE INFLUENCE SPACES(S) AND DIGITAL INFLUENCE WAVES

APPENDIX A. LISTSERV SPACE EXAMPLE: (ASILFORUM) CIRCA
FEBRUARY 2008*

From: johndoe@lists.asil.org
Sent: Monday, February 04, 2008 5:36 PM
To: forum@lists.asil.org
Subject: RE: Resolution adjustment - Red Cross on Guantanamo etc –

Sorry for the mistake, I meant: "I would like reference to some of the issues addressed here:" Also, the "begging the question" statement made no sense. If the suspect is Al Qaeda, fine, have Islamic judiciary, though independence and rigor are most important.

Best, John Doe

From: janedoe@mail.com
Sent: Mon, 04 Feb 2008 11:54:37 -0800

I would like reference to see some of the issues addressed here:
http://www.aldeilis.net/english/index.php?option=com_content&task=view&id=1612&Itemid=107

This would be consistent with early calls by Anne-Marie Slaughter for an international tribunal on the events of 9/11, though she begged the question in her second article by calling for Islamic judiciary. See The New York Times article: Al-Qaeda Should Be Tried Before the World, November 17, 2001. (<http://query.nytimes.com/gst/fullpage.html?res=9C00E4D7153BF934A25752C1A9679C8B63>)

Also: Terrorism and Justice: An International Tribunal Comprising US and Islamic Judiciary Should Be Set Up to Try Terrorists; The Financial Times (London), October 12, 2001.

Best,
Jane Doe

On Sun, 3 Feb 2008 13:20:37 -0500, "Davis, Ben" bdavis@UToledo.Edu said:

Deborah,

* Names and addresses have been removed to avoid any privacy intrusions.

Thank you for your comment. I see exactly what you are saying. I am mulling over an amendment that would respond to that point, to wit:

Proposal.

Under the procedure set forth in Article IX of the ASIL Constitution, the following resolution was adopted at the Annual General Meeting of the American Society of International Law on _____.

A. The American Society of International Law reminds the United States of America of its Centennial Resolution on the laws of war and detainee treatment adopted on March 30, 2006, to wit:

1. Resort to armed force is governed by the Charter of the United Nations and other international law (*jus ad bellum*).

2. Conduct of armed conflict and occupation is governed by the Geneva Conventions of August 12, 1949, and other international law (*jus in bello*).

3. Torture and cruel, inhuman, or degrading treatment of any person in the custody or control of a state are prohibited by international law from which no derogation is permitted.

4. Prolonged, secret, incommunicado detention of any person in the custody or control of a state is prohibited by international law.

5. Standards of international law regarding treatment of persons extend to all branches of national governments, to their agents, and to all combatant forces.

6. In some circumstances, commanders (both military and civilian) are personally responsible under international law for the acts of their subordinates.

7. All states should maintain security and liberty in a manner consistent with their international law obligations.

B. The American Society of International Law calls upon the United States of America to release to the American public all International Committee of the Red Cross reports concerning detainee treatment in the "War on Terrorism" by the United States of America.

Let me know what you think.

Best,

Ben

From: x-owner@lists.asil.org on behalf of Deborah Doe

Sent: Sat 2/2/2008 8:15 PM

To: ASIL Forum

Subject: Red Cross on Guantanamo etc

IMHO what Ben asks to do is already covered in the old resolution. What the Red Cross had to say is much more important. But I think the "labeling

ONLINE INFLUENCE SPACES(S) AND DIGITAL INFLUENCE WAVES

approach" should be done with articles and books and I am not sure whether it would do damage to the work of the Red Cross to ask for the publication of that report. "We do not torture" etc, everybody wants to know the facts and the Red Cross is neutral.

Best, D.

