

# AC Partial Discharge Characteristics and Accumulation Charge after Lightning Impulse in Cast Resin Transformer

著者	Maruyama Hirofumi, Kozako Masahiro, Hikita Masayuki, Iida Kazuo, Umemura Tokihiro, Nakamura Yusuke, Maeda Teruhiko, Higashiyama Masakazu, Nakamae Tetsuo
journal or publication title	20th International Symposium on High Voltage Engineering
year	2017-08-27
URL	<a href="http://hdl.handle.net/10228/00006808">http://hdl.handle.net/10228/00006808</a>

## AC Partial Discharge Characteristics and Accumulation Charge after Lightning Impulse in Cast Resin Transformer

Hirofumi Maruyama<sup>1\*</sup>, Masahiro Kozako<sup>1</sup>, Masayuki Hikita<sup>1</sup>, Kazuo Iida<sup>2</sup>,  
Tokihiko Umemura<sup>2</sup>, Yusuke Nakamura<sup>3</sup>,

Teruhiko Maeda<sup>4</sup>, Masakazu Higashiyama<sup>4</sup>, Tetsuo Nakamae<sup>4</sup>

<sup>1</sup> Kyushu Institute of Technology, 1-1 Sensui-cho, Kitakyushu-shi, Fukuoka, Japan.

<sup>2</sup> Mie University, 1577 Kurima-machiya-cho, Tsu, Mie, Japan.

<sup>3</sup> TOSHIBA Co, 1 Toshiba-cho, Fuchu-shi, Tokyo 183-8511, Japan

<sup>4</sup> TOSHIBA Industrial Products and Systems Co, 2121 Oaza Nao, Asahi-cho Mie-gun,  
Mie 510-8521, Japan

\*Email: < m108117h@mail.kyutech.jp >

**Abstract:** Cast resin transformer (voltage transformer: VT) composed of solid insulation might cause insulation performance degradation by defects such as void existing in the insulation system. In a factory, AC PD test is usually conducted after applying a number of applications of standard lightning impulse voltage to practical VT. Lightning impulse voltage test is made in the power equipment to guarantee surge insulation performance. However, it is reported that withstand lightning impulse voltage test may give influence on AC partial discharge characteristics, especially partial discharge inception voltage (PDIV). This effect is considered to arise from the charge accumulated in the void by the impulse voltage pre-stress. This paper deals with the influence of lightning impulse application on subsequent AC partial discharge characteristics with accumulated charge by the pre-stress considered. An attempt is made to measure impulse partial discharge, and estimate the accumulated charge. Investigation is also made on the impulse pre-stress effect on the subsequent AC PD characteristics for a model specimen simulating insulation system of a cast resin transformer. An attempt is also made to estimate the accumulated surface charge density after the impulse voltage application. Moreover, we measure impulse PD current and then estimate the charge of impulse PD so as to examine the correlation between the impulse PD charge and the accumulated charge estimated from the reduction of the first AC PDIV.

### 1 INTRODUCTION

Cast resin transformer (CRT) composed of solid insulation might cause insulation performance degradation by defects such as void existing in the insulation system. Furthermore, the lightning impulse withstanding voltage test is carried out in many power equipment to ensure the surge insulation performance. In a factory, AC PD test is usually conducted after applying a number of applications of standard lightning impulse voltage on actual CRT. In this paper, the influence of lightning impulse on CRT insulation performance was investigated. We suggest that PDIV decreases due to the influence of the electric field of the accumulated charge on the inner surface of the void on AC PD characteristics [1]. This paper deals with AC PD characteristics and accumulation charge after lightning Impulse in insulation system of cast resin transformer, and compares the result for insulating laminated samples simulating the insulation system.

Figures 1 (a) and (b) show, respectively, photograph and schematic diagram of VT CRT with 6.6 kV / 110 V rating. This VT has two phases: U and W phases. Note that the CRT has been made in such a way that some artificial defects had been introduced in a process of curing of epoxy resin. Hence, subsequent AC PD test for ensuring the insulation dignity revealed that AC PDIV of the 6.6 kV CRT was decreased after 60 kV standard lightning impulse voltage pre-stress [1].

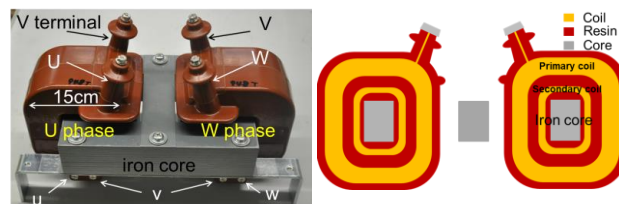

(a) Appearance

(b) schematic diagram

Fig. 1. 6.6 kV class cast resin transformer.

### 2 EXPERIMENTAL

#### 2.1 Cast Resin Transformer

#### 2.2 Model sample of insulation system

The sample is an insulating film laminate structure simulating the insulation system inside the VT. Figure 2 shows the sample structure. The sample has a total thickness  $d = 1.1$  mm composed of laminated twenty one pieces of PET film with a

thickness of 50  $\mu\text{m}$ , and contains one void having a diameter  $2a = 2.0$  mm and a gap length  $t = 150$   $\mu\text{m}$  at the center.  $\text{PDIV}_{\text{before}}$  of the laminated sample was measured in fluorinert as at a rise rate 150  $\text{Vrms/s}$  under AC voltage before impulse voltage pre-stressing. After that, PDIV was similarly measured after applying a standard lightning impulse voltage of positive polarity of 10 kV as a pre-stress. Note that the impulse voltage was determined as the value so that the external electric field at the time of the lightning impulse withstanding voltage test in the actual VT became equal. The experimental setup used and methods were the same as in the previous report [1].

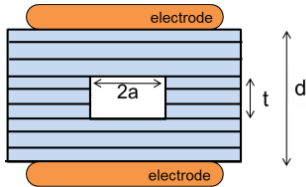
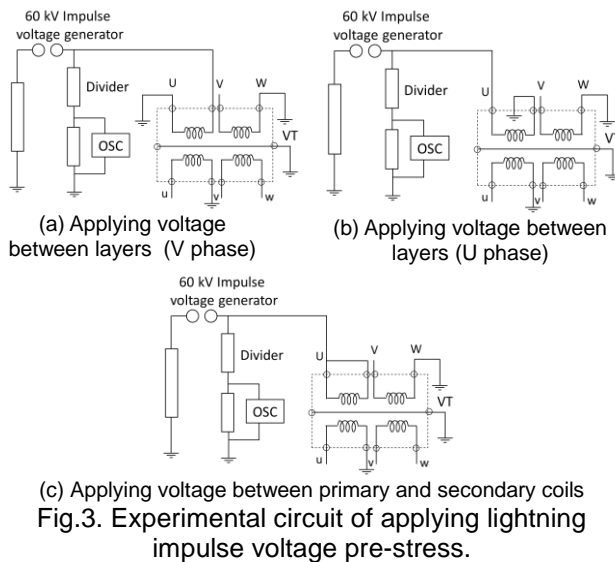

Fig. 2. Structure of model sample

### 2.3 Dependence of first PDIV on rest time

AC PD characteristics for 6.6 kV class VT were measured by varying the rest time elapsed from the application of impulse pre-stress to the initiation of AC PD test. Figures 3(a) to (c) show the connection at applying voltage between the layers in V phase and U phase, and between primary and secondary coils, respectively. Lightning impulse 60 kV was applied to U phase of VT three times.



(c) Applying voltage between primary and secondary coils  
Fig.3. Experimental circuit of applying lightning impulse voltage pre-stress.

(A) Connect the high voltage line to the U-phase side V terminal on the primary winding side, ground the U terminal and ground the W terminal to open the W phase side V terminal. On the secondary winding side, ground the v-terminal on

the U-phase side and open the others. The secondary winding side is always the same connection when pre-stressing. (B) Replace the connection between the V terminal and the U terminal on the U phase side. (C) Connect a high voltage line to the U-phase side V terminal and short-circuit this terminal and U terminal. A 1.2 / 50  $\mu\text{s}$  standard lightning impulse of 60 kV (positive polarity) was applied in the connection of (a) to (c). After the pre-stress, the shortest time of the rest time  $t_d$  until the application of the AC voltage was 5 minutes, AC PDIV and PDEV are measured after a predetermined  $t_d$ , and the dependency on rest time after pre-stressing is evaluated.

## 3 RESULTS AND DISCUSSION

### 3.1 PDIV and charge of model sample by applying ac voltage

Figure 3 shows the transition for each PDIV measurement under the AC voltage after the impulse pre-stress in the simulated sample and the discharge charge amount at each PDIV. First PDIV after pre-stressing with respect to  $\text{PDIV}_{\text{before}}$  decreased to about 0.7 kV. The decrease of PDIV was 75% lower compared to  $\text{PDIV}_{\text{before}}$ . By continuing the PD measurement, the PDIV gently recovers, at that time the occurrence of PD is confirmed in the negative half cycle, and after the application of the positive polar impulse, the same tendency as in the actual VT in which PD occurs in the negative half cycle is observed.

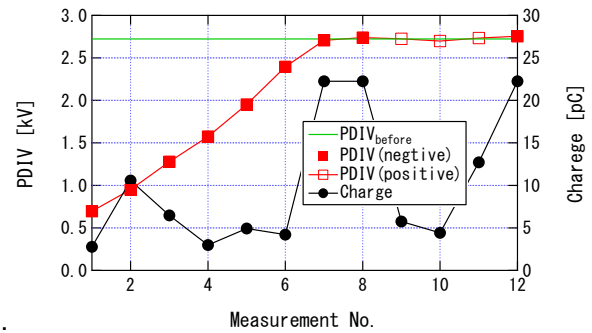

Fig.4 PDIV and PD charge measured under AC voltage after applying the lightning impulse voltage of 10 kV on sample.

### 3.2 Impulse pre-stress effect

Fig. 4 shows the transition for each AC PDIV measurement after impulse voltage pre-stressing in 6.6 kV class VT [1]. It is interpreted that this reduction of AC PDIV contributes to the electric field  $E_{\text{qimp}}$  built by the accumulated charge due to the impulse PD. Therefore, estimation of the surface charge density  $\rho$  of the accumulated charges in the actual VT and the simulated sample is made from the reduction of the first PDIV in Fig.

4 and 5, respectively. PD is generated when the electric field  $E_{\text{void}}$  in the void is equal to the discharge inception electric field  $E_{\text{inc}}$ , and the discharge occurrence phase is assumed to occur at the peak of the AC voltage phase because it is as small as a deviation of about  $19^\circ$  from the peak. Also,  $E_{\text{void}}$  is expressed by the equation (1).

$$E_{\text{void}} = f \cdot E_o + E_{q_{\text{imp}}} \quad (1)$$

In this case,  $f$  is an electric field enhancement factor,  $E_o$  is an external electric field, and  $E_{q_{\text{imp}}}$  is an electric field due to an accumulated charge. Regarding the surface charge density and electric flux density,

$$\rho = D \quad (2)$$

Assuming that equation (2) is established, the surface charge density  $\rho$  is expressed by equation (3).

$$\rho = E_{q_{\text{imp}}} \cdot \epsilon_o \quad (3)$$

From the above, it is found that the surface charge density is  $\rho_{\text{VT}} = 39 \text{ pC} / \text{mm}^2$  in the actual VT and  $\rho_{\text{sample}} = 59 \text{ pC} / \text{mm}^2$  in the simulated sample, which are almost in agreement.  $E_{\text{inc}}$  was calculated by dividing the void gap length  $t$  from PDIV measured value under AC voltage before impulse pre-stressing. With regard to the simulated sample, assuming that the charged area is the entire upper surface or the lower surface of the void, the charge amount  $q_{\text{imp}} = \text{about } 130 \text{ pC}$ . On the other hand, the PD charge amount  $q$  at the time of PDIV under AC voltage is as very small as about  $10 \text{ pC}$  or less, so it is considered that the charge in the void is neutralized by the plurality of PDs and the PDIV gently recovers.

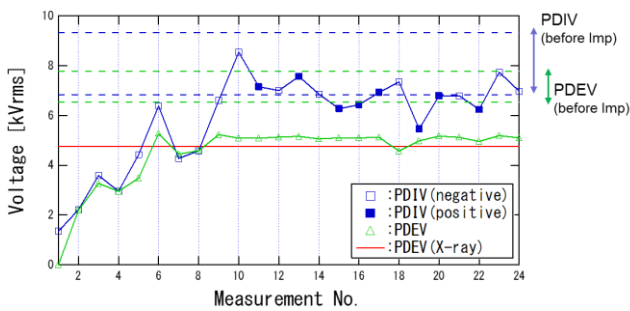

Fig. 5. PDIV and PDEV measured under AC voltage after applying the lightning impulse voltage of 60 kV in VT [1].

### 3.2 Measurement Impulse PD in VT

In order to investigate the discharge charge amount and the accumulated charge amount of the impulse PD, the impulse PD in the actual VT was measured. Fig.6 shows PD detection circuit under

a standard lightning impulse voltage. In this figure, charging current generated at supplying the impulse voltage is cancelled by two VTs having same capacitance connected in parallel [3]. PD pulse current was detected with a high frequency current transformer. A standard lightning impulse voltage with  $1.2/50 \mu\text{s}$  was applied to the VT by a standard lightning impulse generator source. PD waveforms synchronized with impulse voltage waveform were measured with an oscilloscope. Electromagnetic waveform emitted by PD was detected with two loop sensors (LS) located 100 mm away from each CRT to distinguish PD occurrence. The experimental setup used and methods are the same as in the previous report [1].

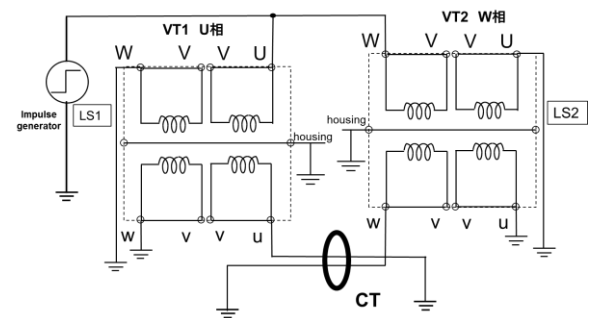

Fig. 6. PD detection circuit for two VT under lightning impulse voltage by differential CT.

Fig.7 shows typical result of current waveforms detected with CT and the loop sensors located near each CRT and enlarged waveform at 30 kV lightning impulse voltage. Note that delay trigger function of the oscilloscope was used to avoid the influence of noises at the rise part of an applied impulse voltage. In the figure, PD waveforms detected with LS are measured synchronously with a signal detected with CT. It means that the loop sensors can detect detailed electromagnetic waves caused by PD occurring in VT. When the rising polarity of the discharge current detected by CT is positive, the arrival time of the LS2 signal is fast, whereas when it is negative, the LS1 signal is acquired quickly. This result suggests the possibility of discrimination of VT in which discharge occurs due to the rising polarity of CT detection signal.

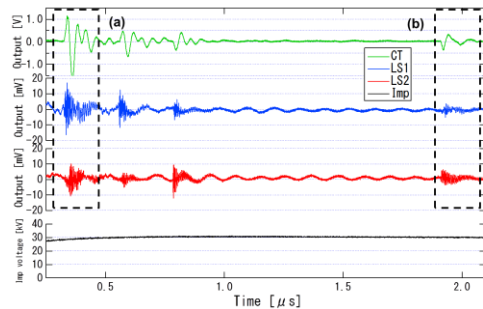

Fig. 7 Detected waveform by differential CT and two loop sensors in VT [1].

Also, the result of obtaining the discharge charge amount from the first wave near (a) the wave front in the figure, 6.9 nC, (b) 1.7 nC at the falling part. The external electric field due to impulse application is 5 kV / mm this time. Impulse PD charge amount was about 1 nC under the external electric field of 10 kV / mm to the void sample [4], and it is confirmed that it is nearly a value. On the other hand, it is found that the charge amount  $q_{imp} = 180$  pC in the simulated sample and the discharge charge amount due to the impulse greatly differed. The reason for this is considered to be the attenuation of the charged electric charge.

### 3.3 Dependence of first PDIV on rest time

Fig.8 and 9 show measurement results of AC PDIV and PDEV at rest times of 24 hours and 72 hours, respectively. In this figure, the number of measurements without the plot of PDEV indicates that the PDEV was not observed during the measurement. Further, the measurement was carried out ten times in fig. 9. From fig. 8 and 9, it is found that in the measurements after 24 hours and 72 hours, the first PDIV is slightly recovered as compared with the measurement result in fig. 5 with rest time of 5 minutes. In the result of fig. 5, the number of measurements required to recover to about 6.0 kV was 6 times. On the other hand, in 24 and 72 hours, the numbers of measurements to recover were 4 times and 3 times respectively. It is considered that the number of measurements required for recovery is decreasing. Next, fig. 10 shows the relationship between First PDIV and rest time. From the figure, it is found that when the rest time is set, the first PDIV recovers to 40% before the pre-stress. However, since PDIV does not recover greatly with the elapsed time, it is thought that it is important to alleviate the accumulated charge in the void due to PD generation.

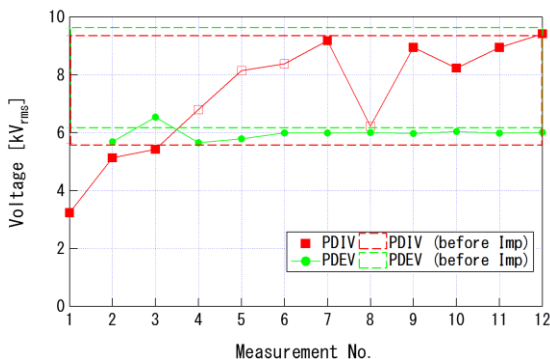

Fig. 8. PDIV and PDEV measured under AC voltage 24 hour after lightning impulse voltage of 60 kV in VT.

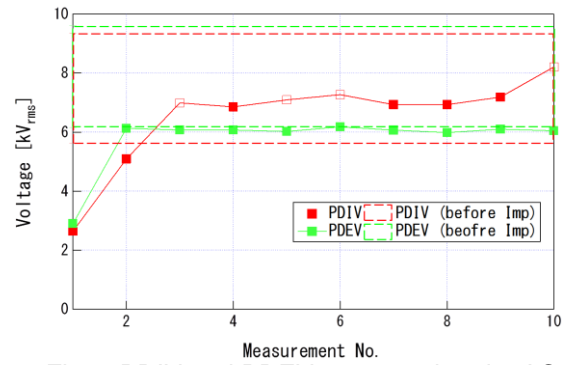

Fig. 9 PDIV and PDEV measured under AC voltage 72 hour after lightning impulse voltage of 60 kV in VT.

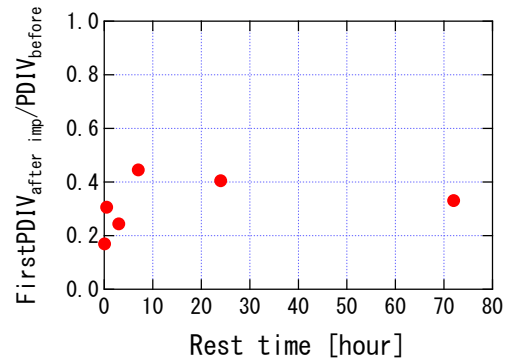

Fig. 10 Dependence of first PDIV characteristic on rest time after lightning impulse in VT.

## 4 CONCLUSIONS

This paper deals with the pre-stress effect of impulse voltage application in an actual 6.6 kV class cast resin transformer (VT), including the results of laminated insulation sample simulating the insulation system. The AC PDIV immediately after impulse application has decreased and then recovered by continuing measurement. From the reduction of First PDIV, the accumulated surface charge densities of VT and simulated sample are estimated,  $\rho_{VT} = 39$  pC / mm<sup>2</sup>,  $\rho_{sample} = 59$  pC/mm<sup>2</sup>. Based on the above, it can be considered that the pre-stress effect in the actual VT could be reappeared with simulated sample. The influence of PD charging by impulse voltage application was quantitatively evaluated. It is confirmed that the charge evaluated from the impulse PD and the PDIV decrease after pre-stress differs by one order of magnitude in VT. In addition, it is confirmed that by setting 72 hours as the rest time, First PDIV recovers to about 40%. On the other hand, PDIV recovery rapidly recovers due to neutralization by PD generation. In the future, we will further investigate the correlation between the discharge charge amount and the accumulated charge amount by impulse application and clarify the influence on the AC PD characteristics after the pre-stress.

## REFERENCES

- [1] Kensuke Matsuo, Atsushi Inatomi, Masahiro Kozako, Masayuki Hikita, Kazuo Iida, Tokihiro Umemura, Yusuke Nakamura, Teruhiko Maeda, Masakazu Higashiyama, Tetsuo Nakamae.: "Impulse and Subsequent AC Partial Discharge Properties in Cast Resin Transformer" ICD, pp.455-458, (2016)
- [2] Masayuki Hayashi, Hajime Tkada, Masahiro Kozako, Masayuki Hikita, Shuhei Nakamura, Tokihiro Umemura, Masakazu Higashiyama, "Study on Time Lag of Void Discharge in Epoxy Resin by Considering Attenuation of X-ray Irradiation Dose" Conference Proceedings of ISEIM 2011, MVP2-20, (2011)
- [3] Ming Ren, Ming Dong and Aici Qiu, "Partial Discharges in SF6 Gas Filled Void under Standard Aperiodic and Oscillating Switching Impulses", IEEE TDEI, vol.21, pp262-272 (2013)
- [4] H.A.Illias, M.A.Tunio, H.Mokhlis, G.Chen, A.H.A.Bakar: "Experiment and Modeling of Void Discharges Within Dielectric Insulation Material Under Impulse Voltage" IEEE TDEI, Vol.22, No.4, pp2252-2260, (2015)