

Affordable Energy Autonomous Wireless Sensor for Day and Night

M. Meli, L. Hegetschweiler

Zurich University of Applied Sciences
Institute of Embedded Systems
Winterthur, Switzerland
Marcel.Meli@zhaw.ch

Abstract— Bluetooth Smart is enabling a new class of sensors where device configuration and data presentation can be done using smart phones, tablets, personal computers and even smart watches. Sensors are equipped with a wireless link that allows them to transfer data to other devices or to get information from them. This opens up many applications with high volume potential. The promise of a large market has led to an abundance of Bluetooth Smart solutions, which is a good thing for the consumer. Competition will lead to improved quality and will drive costs down. But there is also the danger of a maintenance nightmare, if questions such as energy consumption and security are not properly addressed. Sensors need a power source and the way this is often done is to use batteries. They are small and low cost. But maintenance of sensors powered by small batteries means finding them (if one can still remember where they are) and changing the batteries. This is both resource consuming and ecologically expensive. Energy harvesting can help bring the needed autonomy, reduce and even eliminate the maintenance issues as far as energy is concerned. So far however, energy harvesting has proved expensive. In this work, we use a new power management system to design a sensor that runs day and night on energy harvested using a very small solar cell. Part of the energy harvested when there is enough light is stored for use at night. On-the-fly change of the measurement rate allows an optimal management of the energy. We succeeded in designing and building a system with a cost effective solar cell, which can run day and night on harvested energy.

Keywords—Solar; energy harvesting; power management; Bluetooth Smart; microcontroller; storage; advertisement;

I. INTRODUCTION

For several years, total energy autonomy at affordable costs (for the normal consumer) has been a dream for those involved in wireless sensing. A dream often shattered by the cost of harvesters, relatively high energy needs for transceivers or the limitations of the energy storage elements. Recent progresses in power management, wireless sensors and harvesting techniques are helping bring that dream one step closer.

In this work, we present a system that can harvest energy from a small solar cell, use part of that energy to make measurements and sent the results wirelessly to a gateway. The rest of the energy is stored in order to continue measurements and communication when there is not enough light. The system already works with power inputs in the range of 1-3 microwatts. It can also combine different information from the harvester and storages to determine the fitting communication interval and thus help optimise the use of energy, for the sensor and even for the receiver. Despite this complexity, BOM and size remain small, thanks to the use of a small solar cell.

With day and night, we respectively refer to conditions when there is enough light (day) to allow harvesting to take place and when there is not enough light (night).

II. MOTIVATION

There are several reasons that motivated us to work towards a low-cost sensor, powered with harvested energy and capable of working day and night. Foremost are the usefulness of such a device and the need to make it economically affordable.

- There are many applications where parameters need to be monitored during the day and at night. Depending on use cases, one might want to transfer data in real time or store that information for a later transfer. In both cases, measurements still need to be made both during the day and at night time.
- In some cases, the effective lifetime of the sensor is short. A primary battery may then be the best option. If a longer lifetime is required, it is important to deal with questions related to data transfer and to maintenance. The higher the number of sensors and the more important maintenance issues are. Replacement of the energy sources is a problem. In principle, well designed low power systems work for a very long time, reducing the number of battery changes. Even better is a system where batteries do not need to be replaced at all. Energy harvesting can

be used as energy source to eliminate the need to replace batteries. However, it needs to be appropriate in the environment of the application. Here, we assume an environment where there is regularly enough light. Solar cells are therefore the obvious source of energy.

- The use of energy harvesting often leads to expensive products that are therefore not affordable for many in the consumer market. This means that there is a need for a design that is also affordable to customers.

We set ourselves the goal of designing and testing a sensor comparable to our previous day-only Bluetooth Smart RH&T sensor [4], with the additional feature of having it work at night as well. The original day-only sensor was powered with harvested energy, using a small solar cell. It obviously stopped working once there was not enough light. Improved versions were made for indoors use, thanks to appropriate solar cells (e.g. Dye Sensitized Solar Cells from GCell). We also built variations that could be powered using LEDs as harvesters, further reducing costs, at the expense of the measurement rate and illumination [5].

The version presented here adds a booster/power management device that makes the harvesting more efficient and takes over critical power management tasks. This allows the implementation of interesting management options in software. The new device and its support in hardware and software should be available for less than 1 dollar in volumes (the manufacturer should be contacted for exact pricing). Options such as the use of larger energy storage (e.g. super cap) will evidently add the cost of that extra component. The use of a booster that can already work from 3 μ w (cold start) or 1 μ w (hot start) means better options for harvesting. This translates to lower costs, since a smaller solar cell can be used or better performance achieved. It enables better performance since more energy is available for the load.

The following requirements were at the heart of the design.

- The first version of the sensor should use a small harvester (the same solar cell from IXYS as in our previous work [3]) and be able to send data at least every 30 seconds, day and night. Prices should be kept low by using low cost components.
- The design should yield a platform allowing trials with a variety of solar cells and sensors (photodiodes, DSSC cells, ... etc.), in order to enable further work towards costs reduction and better performance.
- It should be possible to work with a variety of wireless systems and transceivers (different voltage levels and output currents).
- It should be possible to try different power management schemes by adapting the firmware, in order to improve the performances of sensors or receivers.

III. THE DESIGN

Fig 1 shows a basic block diagram of the design. It includes microcontroller, sensor, radio, power management and energy harvester. Energy is scavenged using a small solar cell that can be placed near a window or other light sources. The cell can easily be changed to accommodate other possibilities such as photodiodes, indoor cells ... etc. A single element solar cell was preferred in order to reduce the negative effects of shadows on the harvesting efficiency. This also helps keep the cost of the solar cell down.

The EM8500 is used as booster/power management. It is a very important part in the system. Up to 2 storage elements can be associated to the device. The STS (Short Term Storage) is generally a smaller capacitor that will charge fast and allow a fast reaction. The LTS (Long Term Storage) is an element that can store more energy. The EM8500 boosts the voltage of the small solar cell (minimum of 0.3 V) to a value that is suitable for the electronics. It also implements a configurable Maximum Power Point Tracking (MPPT). The power management chip delivers information about the status of the storage elements and the status of the harvester. The EM8500 can be configured using EEPROM cells, which reduces the number of external components needed. The configuration includes the setting of different internal comparator levels in order to define the voltages at which the energy storage elements operate. The voltage needed for the load is also defined. Protection levels can be configured, in order to allow the use of a variety of storage elements. The device can communicate with a microcontroller using a serial link (SPI or I2C). Using this communication link, the various configurations can be changed on-the-fly. Similarly, status information can be retrieved using the serial link. This is possibly the most interesting aspect of the EM8500. It enables a combination of power management in hardware and firmware in order to adapt the system and achieve the best performance, depending on the energy available and the energy that is being harvested. It eases the use of previously recorded harvesting patterns to make predictions and consequently synchronise harvesting and work load. Combining several elements in order to create a system with an emergency back-up (when every other source fails) is also possible, thanks to the monitoring and communication features.

For the LTS, we chose a value of 100mF. For the STS, we worked with 100uF. These values were chosen so as to fulfil our specifications. With a small STS, the system starts working early, even when there is not enough energy in the LTS. It will already store enough energy to make a measurement and send data in the case of a low-power Bluetooth Smart sensor requiring less than 100 μ J. With the LTS fully charged, one can work the whole night at the measurement rate that we set.

The solar cell is a KXOB22-12X1 from IXYS [3]. Other cells are also possible.

As sensor, we used an SHT21 of Sensirion. This device enables the measurement of relative humidity and temperature [7].

The embedded system consists of a low power microcontroller and a Bluetooth Smart radio. It can be used in

connected or in non-connected mode. In this phase of the work, the wireless link was used in a beacon mode (non-connected). There are several device options for Bluetooth Smart [6].

- The system is switched on or off as required.
It is switched on when there is enough energy. It then performs the needed measurements, wirelessly broadcasts the results and is switched off.
- If there is enough energy in the system, the measurements and transmission of data can be performed at regular intervals. A timer available in the EM8500 is then used for setting the measurement intervals. The time interval can be changed on the fly, after consideration of the energy available in the system and the energy that can still be harvested.

IV. MANAGING THE ENERGY

Several strategies are possible in order to run the sensor day and night. Basically, energy that is harvested is used to make measurements and send data at the chosen rate. The extra energy is accumulated in the long term storage. During the night or when there is no longer enough energy to harvest, the long term storage is used to power the load. It is then important to monitor the use of the energy such as to allow the whole night to be covered (if this is required by the application). A good part of the work is done by the power management that will monitor the different levels of the storages and the harvester. These values are then read by the application microcontroller and used in an algorithm to set the measurement and transmission rate. The EM8500 needs very little energy to perform its management tasks. It is therefore advantageous to switch off the load whenever possible.

V. EVALUATION AND RESULTS

The sensor was built and used for measurements over several days. It was placed near a window and data frames were captured using a Bluetooth Smart frame logger developed at ZHAW-InES for such purposes. The captured data was then entered a database for further analysis. The frames included the temperature and humidity measurements, but also information about the state of the different storages and the harvester. This information is crucial for the monitoring and prediction of energy level and changes of the energy consumption patterns. The analysis of this information allowed us to gradually improve the power management strategy. Once a satisfactory version of the firmware was available, the voltage levels of the LTS, STS elements were also measured and logged for analysis using a power analyser [8]. Similarly the LDO output used to power the embedded system and the current flowing into the embedded system were recorded. All these information allowed us to make a verification of the energy needs and consumption of the system.

A version of the sensor that automatically adapts the measurement rate and a version with a fix measurement rate were programmed and verified together over 2 days. It was shown that when sufficiently energy is available, it is possible to run the sensor faster. Once the LTS is full, the extra energy harvested can be used to increase the rate of measurements

(otherwise it is lost). The measurement rate can then be decreased as the energy available goes down.

Some of the results are shown below, on a larger format (to help the understanding). The results are commented with Figures 6,7,8. The reader is kindly asked to refer to those parts.

The sensor as designed runs day and night, providing that it is placed in a position where it can harvest enough energy for a few hours.

VI. CONCLUSION

In this work, we have designed a sensor that can be powered day and night on energy harvested using a small single solar cell. The use of a new power management helps improve the efficiency of the system. This enables a cost optimization of the hardware and software and opens the door to low cost wireless sensors. Compared to our previous designs, the extra cost is evaluated at \$1 and the price for the LTS.

Future works will concentrate on further cost reductions and the use of different solar cell elements. Energy management algorithms will also be further developed to allow more energy savings. The strategy to refine energy consumption of the receiver will be further developed to allow the use of receiver that require a small energy budget, for instance by synchronizing the timing of the receiver and that of the sensor.

ACKNOWLEDGMENTS

We would like to thank EM Microelectronic Marin for providing EM8500 devices. We thankfully acknowledge the help of our team colleagues (especially Claudio Zopfi) in recording and analyzing Bluetooth Smart frames.

Bluetooth, Bluetooth Smart, Bluetooth Smart Ready are registered trademarks of Bluetooth SIG, Inc. All other registered trademarks or trademarks are the property of their respective owners.

REFERENCES

- [1] Datasheet of the EM8500
<http://www.emmicroelectronic.com/sites/default/files/public/products/datasheets/8500-ds.pdf>
- [2] Fact sheet of the EM8500
<http://www.emmicroelectronic.com/sites/default/files/public/products/datasheets/8500-fs.pdf>
- [3] Datasheet IXYS solar cell
<http://ixapps.ixys.com/PartDetails.aspx?pid=5616&r=1>
- [4] Indoor battery-less temperature and humidity sensor for Bluetooth Low Energy Paper on Gcell
M. Meli; U. Beerli; Wireless Congress, Munich November 2011
<https://www.zhaw.ch/storage/engineering/institute-zentren/ines/forschung-und-entwicklung/wireless/dokumente/paper-indoor-battery-less-sensor.pdf>

- [5] Meli, Marcel; Roth, Niklas; Gutzwiller, Pius. Wireless sensing using LEDs as very low-cost energy harvesters. In: Embedded World Conference 2015. Nuremberg: WEKA FACHMEDIEN.
<http://pd.zhaw.ch/publikation/upload/208118.pdf>
- [6] Comparing the energy requirements of current Bluetooth Smart solutions; Embedded World, February 2014, Nuremberg
<http://pd.zhaw.ch/publikation/upload/207967.pdf>
- [7] Datasheet of SHT21
https://www.sensirion.com/fileadmin/user_upload/customers/sensirion/Dokumente/Humidity_and_Temperature_Sensors/Sensirion_Humidity_and_Temperature_Sensors_SHT21_Datasheet_V4.pdf
- [8] <http://www.keysight.com/en/pd-1123271-pn-N6705A/dc-power-analyzer-modular-600-w-4-slots?cc=CH&lc=ger>
<http://cp.literature.agilent.com/litweb/pdf/N6705-90001.pdf>

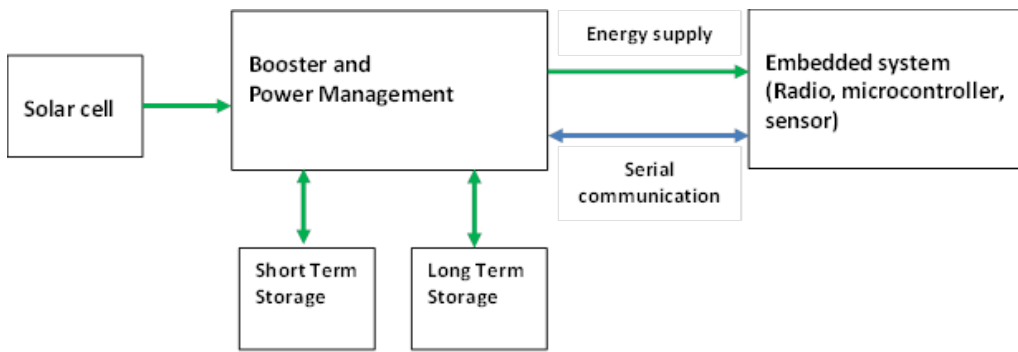

Fig. 1 Basic block diagram of system

The same hardware can be used to enable different power management strategies for the sensor and for a the receiver (or receiving gateway).

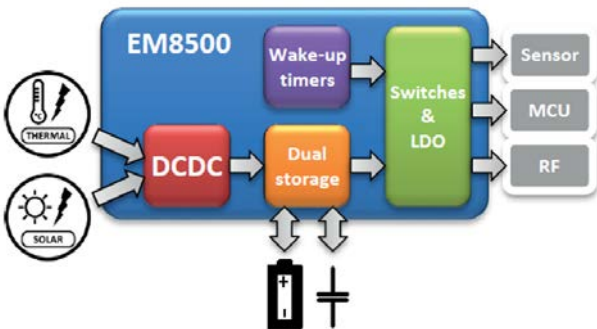

Fig. 2 The EM8500 can be used with solar or TEG energy harvesters [2]

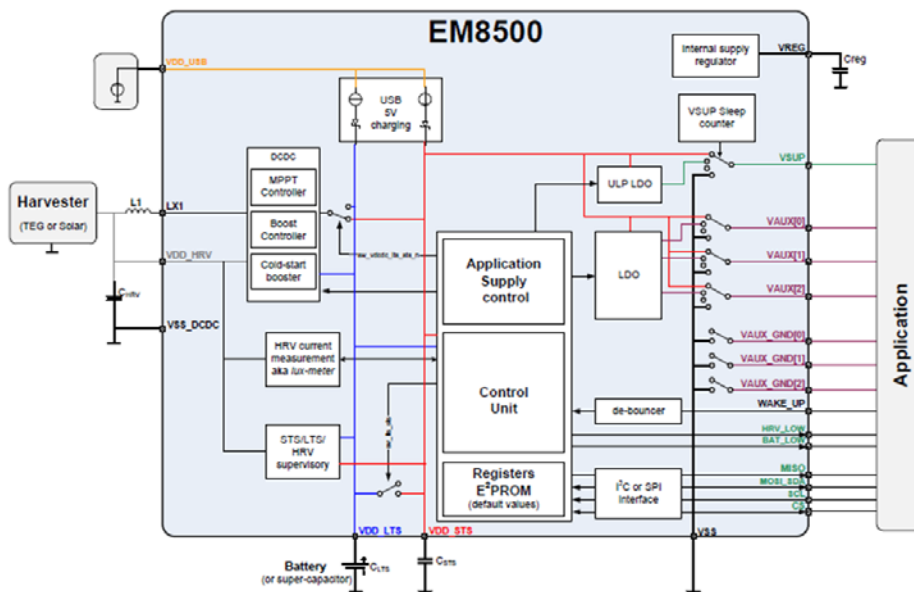

Fig. 3 Internal block diagram of the EM8500 [1]

Boosting is followed by power management to optimise the energy transfer and to save energy in the different storage elements. The STS allows the system to start working quickly. The LTS allows the system to store more energy. Levels of storage, LDOs output voltages can be configured using the EEPROM. Configuration on-the-fly is also possible for a certain number of parameters. This flexibility enables the application to adjust the measurement rate according to the energy available in storage elements and the input of the harvester.

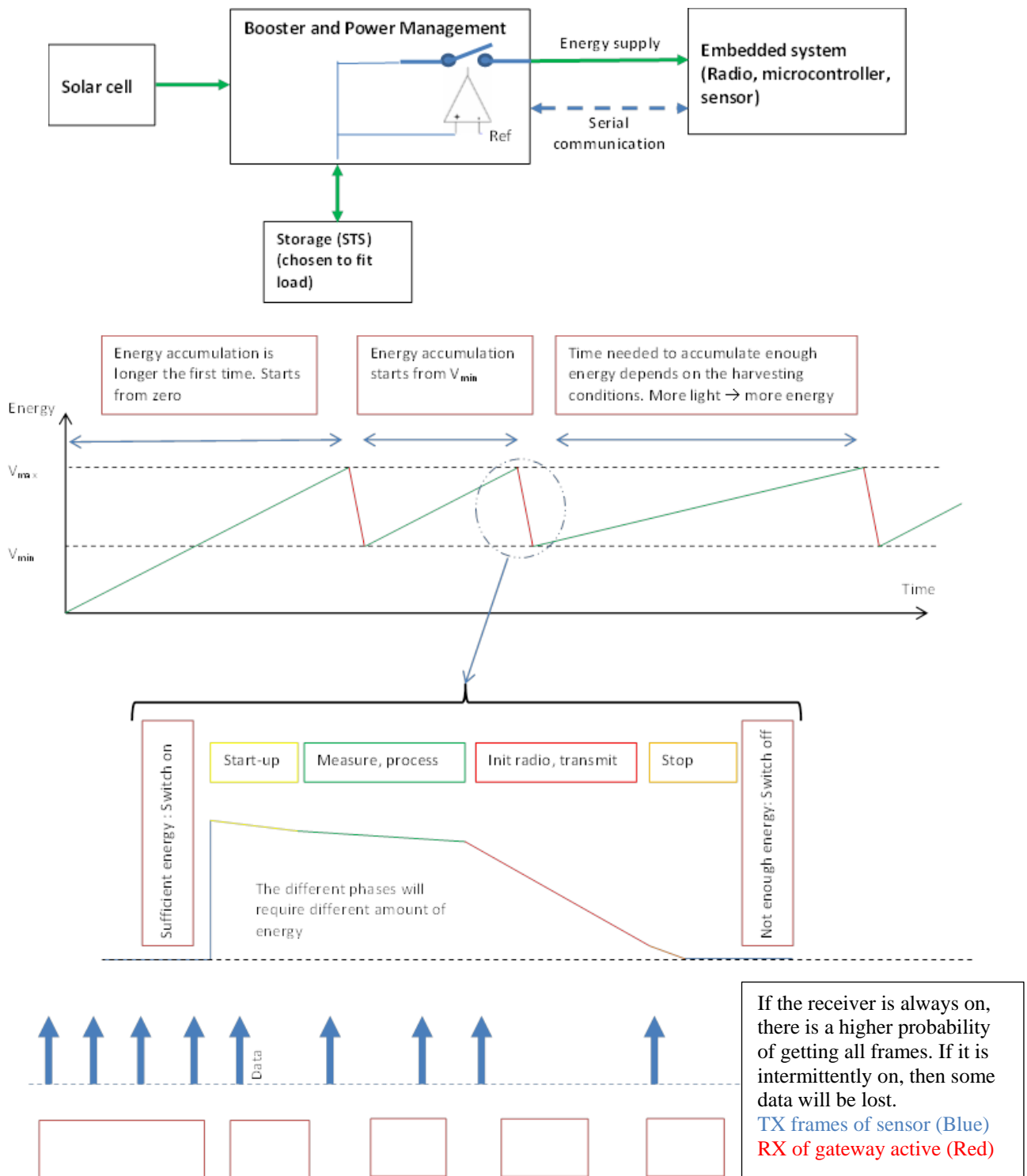
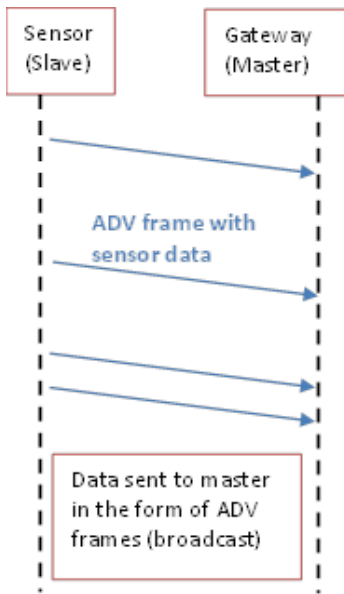

Fig. 4 Simple configuration of system (a,b,c,d)

In this configuration, the system is switched ON/OFF depending on the energy available in the STS. The storage should be so dimensioned that the energy is enough for the application. When a given quantity of energy is available, the power management turns the embedded system on. Work is done. The embedded system is then switched off when that work is done or when there is no longer enough energy in the STS. Switching off the embedded system reduces the losses that are related to the leakages in embedded system. However, this gain in energy can be offset by the energy needs at startup. Therefore, the interval between frames and the total leakages should be taken into account for trade offs.



	Master/gateway is at a fix position (not mobile)	Master is mobile (e.g. a smartphone)
Receive function of the gateway always ON	Case 1: Frames are received. Much energy lost by master (always ON). Probability to get all frames is high	Case 4: Frames received regularly when within radio range. Much energy lost by master (always ON). Probability to get all frames is high when in radio range.
Receiver of gateway works in intermittent mode. The Rx is sometimes ON and sometimes OFF	Case 2: Frames are received. Less energy lost by master while receiving Probability to get all frames goes down	Case 5: No frame received when radio out of range. Update slightly worse than in case 2 if radio often out of range. Corresponds to what is seen today with smartphones. Behaves as in case 2 once radio is in range.
Receiver of gateway is in synch with sensor Using previous received frames interval, the master calculates when the next frame is likely to be sent. It then times itself in order to switch its receiver ON before that event, and then get the data. In between, the receiver is OFF. Thus savings of energy.	Case 3: Frames are received. Less energy is lost by master in receive mode. Probability to get all frames is high.	Case 6: Difficult to implement if the master is often out of range because of mobility. It would need to be in radio range long enough to measure the time interval and use it for synchronisation.

Fig. 5 (Including table) possible combinations for energy management strategy on receiver side
This shows the benefit of timing the work of the sensor.

If the receiver is always ON, much energy is lost, since it is active when no data is sent. Intermittently switching the receiver ON/OFF helps reduce energy needs of the gateway, but might lead to the loss of much data.

By introducing time prediction, energy can be saved on the receiver side without losing too many frames. In its simplest way, the time interval between 2 received frames will be used as the interval to the next frame. In a system with solar harvesting, this is likely to be good enough. Some tolerance should be introduced in order to cover variations. We will say more about time prediction algorithms in a future paper.

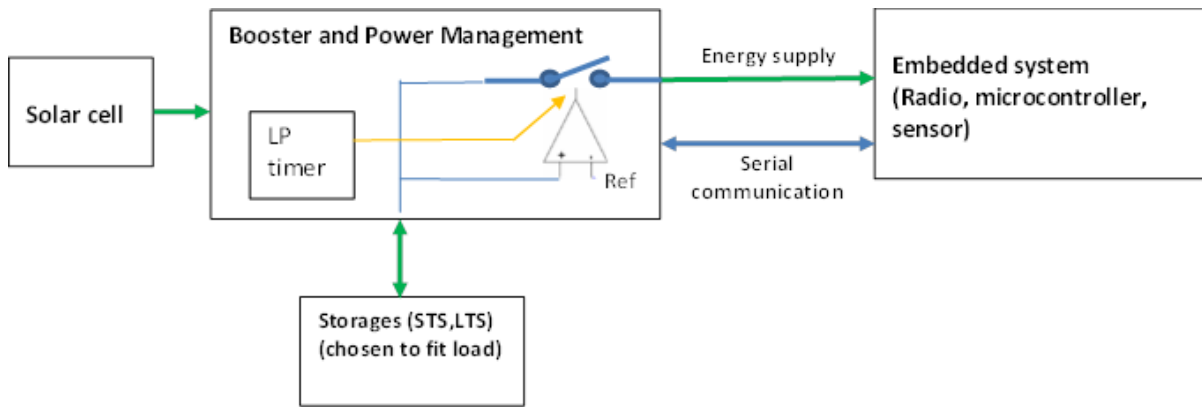

Fig. 6. Block diagram of a configuration where the timer is used to sequence measurements or communication. This is the variation implemented in this work.

The LTS is used in order to keep the system active for the work at hand. The timer that is available on the EM8500 can then be used to space the sensing or communication activities. In this case, the bidirectional communication between the embedded system and the EM8500 is needed. At programmed intervals, if there is sufficient energy, the embedded system is powered up. It then makes the measurements, transmit data and switches itself off by sending the needed command to the power management.

All extra energy is used to build up energy reserves in the long time storage, resulting in a more efficient use of energy. Building up on this, the load power-up interval can be adjusted depending on the available energy (that is the energy available for harvesting and the energy available in the storage).

On the receiver side, a timed transmission will help synchronise the receive operations and save energy. It is clear that the tolerances of timers have to be taken into account.

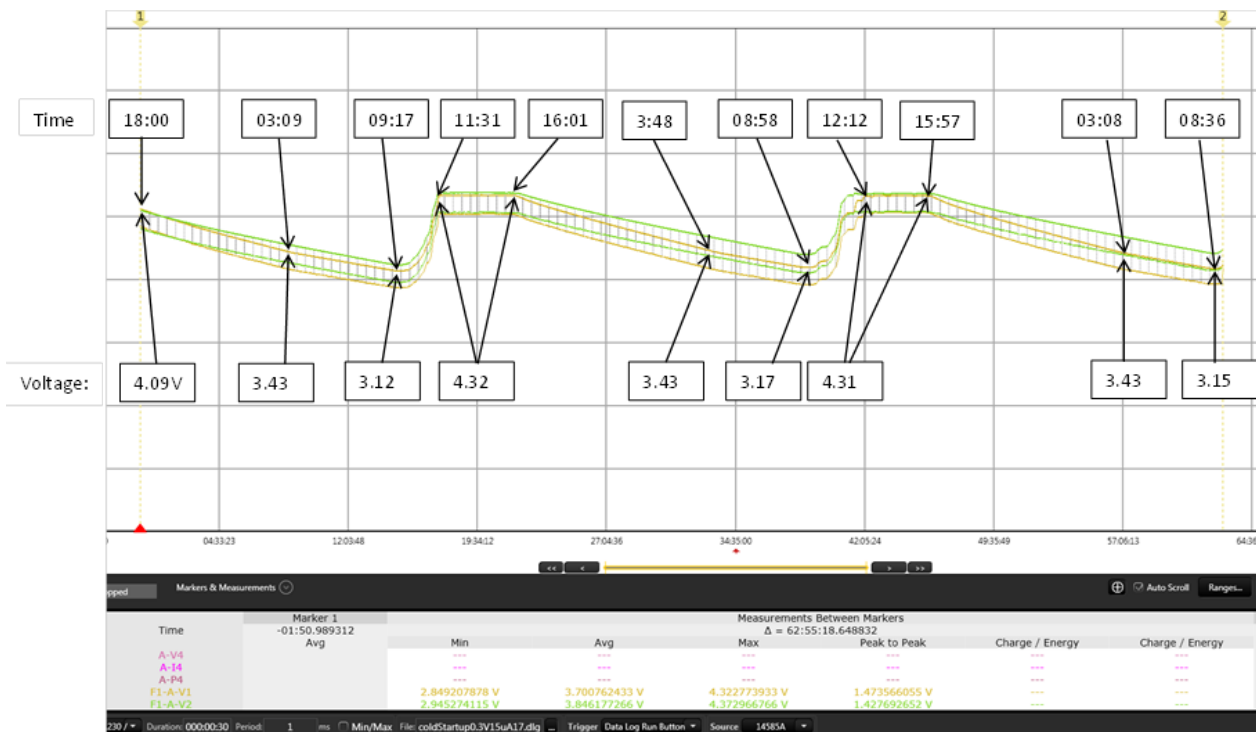

Fig.7 LTS voltage recorded over 2 days (about 63 hours between marker 1 and marker 2) for 2 sensors.

- Voltage on LTS of sensor ID 38, active every 30 seconds (start up, measure, send).
- Voltage on LTS of sensor ID 35, frequency of activity (10-30s intervals) depends on charge state. LTS fully charged: Sending BLE packet every 10 seconds (not activated at the moment)

LTS over 3.43V:

There is enough light: active every 15 seconds

There is not enough light: active every 20 seconds

LTS Under 3.43V: active every 30 seconds

The recordings show the time of the day and the measured voltage. Every time the sensor is powered up, there is a small fall in the voltage (therefore the impression of double traces).

The sensors were at the window, in winter (mid-January 2016, Winterthur, CH).

At about 9:17 on the first day, the LTS storage element shows the lowest value. The sensors have been active during the night, draining energy from the 100mF cap. There has been no light to allow recharging.

Between 9:20 and 11:30, there is sufficient light. Enough energy is harvested to allow the LTS to be filled up to 4.3V, while the sensors are still measuring and sending data. As long as there is enough light, the LTS remains fully charged.

From 16:01, there is no longer enough light to do the work and keep the LTS full. The voltage starts to go down.

The system works all the night, using the energy in the LTS, until 9:00 the following day. And so it goes on....

Since sensor 38 is less active than sensor 35, its energy level stays higher.

When there is enough energy, sensor 35 is made to work faster. This is possible thanks to the on-the-fly update of the power management parameters, based on the monitoring it does. It is therefore possible to easily "tune" the system to adapt it to the available energy and the foreseen harvesting rate. This comes at little costs, since the parameters are available in the power management system.

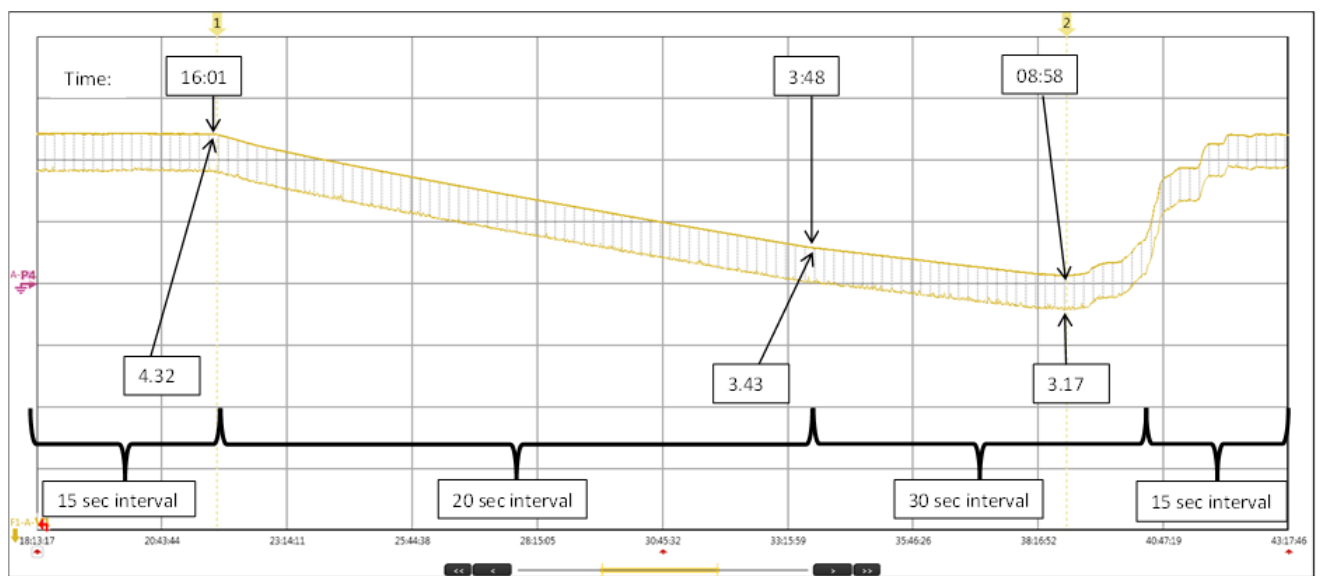
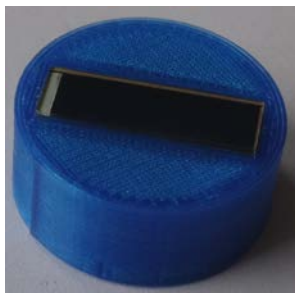

Fig. 8 shows the LTS voltage of sensor 35 on the second night and the frequency of activities at different periods. The time interval between the transmissions is reduced as the LTS voltage (energy) goes down.



The sensor is made up of 2 PCBs. The first carries the EM8500 and storage elements. It also allows the solar cell or a small battery to be connected.

The second PCB carries the wireless embedded system

Solar cell size is 20mm x 6mm

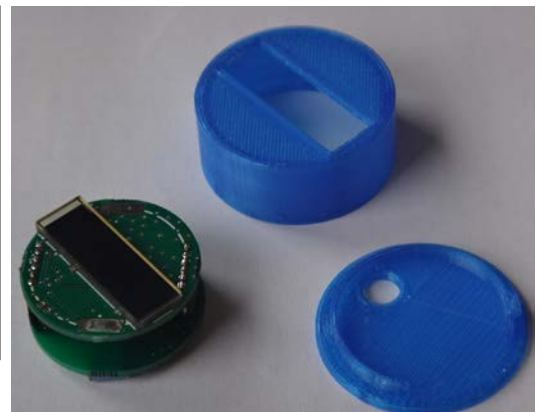

Fig. 8 (a, b) Pictures of the sensor and the small solar cell
Both stacked PCBs occupy 23mm diameter x 10mm height
The enclosure is 28mm diameter x 12mm height