

Powering Long Range Wireless Nodes with Harvested Energy

M. Meli, P. Bachmann

Zurich University of Applied Sciences
Institute of Embedded Systems
Winterthur, Switzerland
Marcel.Meli@zhaw.ch

Abstract— LPWAN systems are important elements in IoT networks. They allow small amount of data to be efficiently transferred over long distances, reducing the number of gateways. Long range (or improved robustness) often comes at the cost of data rate, meaning that frames require more time and thus more energy to be sent or received. This increase in energy affects the ability of using cost-competitive energy harvesting techniques for LPWAN systems, compared to WPAN systems. In this work, we present a design that uses energy harvested from a relatively small indoor solar panel to power a sensor node and enable data transmission with LoRa. Results from first measurements show that using the module near a window will provide enough energy to measure and transmit hundreds of messages per day. This is more than the amount of messages that can actually be sent per day per node on the public LPWAN network of some telecom operators.

Keywords—LPWAN; Booster; Wireless; Power Management; LoRa; Energy Harvesting;

I. INTRODUCTION

It has been obvious for several years that there are considerable range and energy gaps between low-power Wireless Personal Area Network (WPAN) such as Bluetooth Smart, ZigBee and other 802.15.4-based protocols on one hand and wireless Wide Area Network (WAN) systems on the other hand. Several firms have started filling up the gap by designing or deploying appropriate technologies [1] called LPWAN (Low-Power Wide Area Network). There are now several protocols on the market (or in the labs) that address that need. Fig.6 shows the energy requirements while sending a 50-character SMS with a GSM modem. A comparison with a similar use case using a LoRa modem (Fig. 11) clearly shows that the amount of energy required for GSM is much higher. One reason is of course the fact that GSM was not designed to be energy-efficient for small amount of data. However, there are many applications that only generate and transmit a very small amount of data over a long distance (tens to hundreds of

bytes per day). For such applications, a LPWAN system is a better alternative. Examples can be taken from the Swisscom LPN page [6].

Most of the devices that use LPWAN protocols are powered using batteries or using mains. The long range features often come at the expense of a (very) low data rate, meaning that more time is spent in sending or receiving. This increase in transmit/receive time contributes to the increase of the required energy. In the case of WPAN, the data rate is usually high (e.g. 1Mbps for Bluetooth Smart). LPWAN systems require more energy than WPAN system. Here also, a factor of 10 to 100 is not unusual. Hundreds of bytes can be sent using Bluetooth Smart with less than 100 microjoules. LPWAN systems are not often used with harvested energy. One reason is that the energy requirements are higher, making it difficult to bring energy autonomy at acceptable costs to LPWAN.

The Swiss telecom firm Swisscom is currently installing the needed infrastructure for LPWAN based on LoRa. Low power nodes in that infrastructure (class A) can send up to 144 messages per day (XXL service with 144/14 for uplink/downlink). This corresponds to transmitting about 1 message every 10 minutes [6]. It seems to us that this time should be enough to facilitate the accumulation of enough energy, and thus allow sensors of this class (A) to be powered with harvested energy.

In this work, we present a module that can harvest energy from a small solar panel, use that energy to make measurements and send the results wirelessly to a LoRa gateway. The firmware can later be modified to allow extension of the measurement period to times when there is not enough light. The maximum number of messages that can be sent per day using the public network is well covered.

II. MOTIVATION AND CONSTRAINTS

Although LPWAN systems use more energy than WPAN system, it is still possible to power them using harvested energy. The long transmission (or reception) times place important constraints on the peak currents. This can be dealt with by taking advantage of the long time intervals between transmissions to refill the storage elements. To avoid using large harvesters (expensive) it is therefore important to pay special attention to the power management. Our prime motivation in this work was the design of a system using the LoRa LPWAN system. The system should function outdoors but also indoors and allow us to make trials to build up experience for further development towards a system that could work day and night. The system should allow us to test the size limits of the solar cell in order to later allow a cost optimization. It should therefore be possible to replace the solar cell so as to test other harvesters. The accumulation of energy should also be possible, with timing features enabling the appropriate management of the energy over long time periods. Basically, we sought to do for LPWAN what we have previously achieved for WPAN systems [4]. The obvious difference being the size of the solar cell and the energy needed to send a frame.

III. THE DESIGN

In previous works, we established the order of magnitude of the energy generally required by a LoRa transceiver. We achieved this by making several measurements. The results are summed up by Fig. 12. It can be clearly seen there that tens to hundreds of millijoules could be necessary for each LoRa frame, depending on factors such as baud rate, output power, frame size. Note that the LoRa device used in these early measurements are different from those used in the solar-powered module described in this work.

Fig.1 and Fig.2 show basic block diagrams of the design. The main elements are: microcontroller + radio (SX1272), sensors, power management and energy harvester. Energy is scavenged using a solar cell that can be placed near a window or other light sources or where there is enough light. The cell can easily be changed. A single element cell is preferred if shadows are likely.

In order to work indoors with a small solar panel, it is important to use a booster and power management system that consume only a small fraction of the harvested energy. The rest is kept in storages until it is time for use. In this design, the EM8500 is used as booster and power management device [2]. Up to 2 storage elements of various capacities and types can be associated [Fig.4]. The STS (Short Term Storage) is generally a smaller capacitor that will charge fast and allow a fast reaction. The LTS (Long Term Storage) is an element that can store more energy. The EM8500 boosts the voltage of the solar panel (minimum of 0.3 V) to a value that is suitable for the electronics. It also implements a configurable Maximum Power Point Tracking (MPPT). The management chip delivers information about the status of the storage elements and the status of the harvester. The EM8500 can be configured using EEPROM cells. This reduces the number of external components needed. The configuration includes the setting of different internal comparator levels in order to define the

voltages at which the energy storage elements should operate. Protection levels can also be configured, in order to allow the safe use of a variety of storage elements. The device can communicate with a host microcontroller using a serial link (SPI or I2C). Using this communication link, the various configurations can be changed on-the-fly. Similarly, status information can be retrieved using the serial link. This is a very interesting aspect of the EM8500, since it makes it possible to combine hardware and firmware in order to achieve the best performance, depending on the energy available both in the storages and in the surroundings. EM Microelectronics provides a tool for easy configuration of the over 26 registers of the EM8500. The tool also includes a plot generator for a better visualization of the functionality. The EM8500 needs very little energy to perform its management tasks.

The LTS and STS were chosen (dimensioned) so as to make it possible to perform measurements and send the results in the most demanding LoRa mode (SF12 with +14 dBm output power).

Due to the high current drawn by the system when transmitting, a power management support circuitry was added to allow enough current to be quickly drawn for the load, without leading to a drop of the voltage below the minimum acceptable for the embedded system. This support combines hardware and software elements. The main functions of the EM8500 in this design are: the management of the energy in the storages, the efficient boosting of the voltage from the solar cell, the generation of appropriate signals for the control of the power stage. The embedded system used could draw up to 40mA @ 3V and 14dBm.

The solar cell is a device from GCell [5]. Several sensors were built to the system, allowing parameters such as temperature, humidity, pressure (altitude), acceleration to be measured [7,8,9]. A picture of the populated PCB and the solar panel is shown on Fig.3

IV. EVALUATION AND RESULTS

The sensor module was built and used for measurements. To test the harvester in certain defined light conditions, it was put in a light chamber equipped with LEDs. By applying a defined voltage (earlier determined in the calibration process using a lux-meter) to these LEDs, the light intensity can be set up precisely between 0Lux and 2000Lux. In this measurement conditions, the solar module is illuminated equally, which results in maximum energy output at the specific light intensity.

Generally, LTS has to be charged from 0V only once after power off. After a first restart, the voltage should not go under

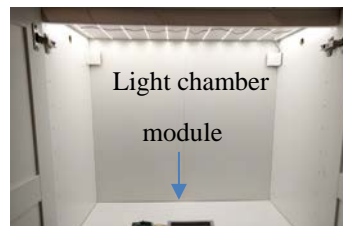

the minimum application voltage of 2.4V, assuming that a minimal light intensity of 600Lux is present. With no energy

harvested by the solar cell, the voltage will drop due to the energy consumption of the power management, leakages of the circuit and of the 220mF supercapacitor used as LTS. Therefore, the most interesting charging time is from 2.4V to the threshold voltage 3.7V. The table below shows the results of this measurement. The voltage was monitored directly at LTS with a 10MOhm oscilloscope probe.

V_{LTS_start}	V_{LTS_stop}	time	C_{LTS}	Light intensity	Voltage applied to LED strip
2.41V	3.69V	2912s	220mF	600Lux	8.24V
2.42V	3.69V	482s	220mF	2000Lux	9.25V

The energy between the start and stop voltages corresponds to more than 850millijoules, which is more than enough to make measurements and send frames in SF12 at 14dBm.

The module was then placed near a window and data frames were sent to a LoRa receiver connected to a PC. The frames included the temperature and humidity measurements and other parameters needed for debugging (Fig.5 shows the format used for a frame.). The voltage levels of the LTS and STS elements were also measured and logged, allowing an evaluation of the energy requirements of the system.

Some of the results are shown and commented in the pages below, on a larger format (to help the understanding) (Figures 7-10). The reader is kindly asked to refer to those parts.

We also placed the module in the office with illumination conditions of about 500-700 lux (artificial light). The radio was programmed to run in SF10 mode and +14dBm. An examination of the recorded data showed that measurements and a radio transmission were possible every 12-15 minutes. This is close to the maximum number of transmissions allowed by Swisscom in Switzerland when the device works in class A.

V. CONCLUSION

In this work, we have built a LPWAN wireless sensor that is powered using energy harvested using a solar cell. The parameters measured can be sent to a LoRa gateway in the different spreading factor configurations and output power modes. An important challenge is a power management system capable of delivering the required current, especially when maximal range is needed. The system works well when placed near a window and generates more than enough frames at 1000Lux. Even on a cloudy day, enough energy can be harvested to allow thousands of measurements and messages. In an office illumination environment, it performs close to the acceptable limits in SF10 mode. The system is a good platform

for further tests, especially in order to optimize performance in low-light conditions.

Future works will concentrate on developing a version for day and night and reducing the size/cost of the system.

ACKNOWLEDGMENTS

LoRa, Bluetooth Smart, ZigBee, are registered trademarks of their respective owners.

REFERENCES

- [1] Refence to LPWAN
<https://en.wikipedia.org/wiki/LPWAN>
- [2] Datasheet of EM8500
<http://www.emmicroelectronic.com/>
- [3] Information about LoRa
<http://www.semtech.com/wireless-rf/internet-of-things/>
- [4] Affordable Energy Autonomous Wireless Sensor for Day and Night
M. Meli; L. Hegetschweiler Embedded World 2016. Nuremberg
- [5] Information about solar cell from GCell
<http://gcell.com/>
- [6] Information from Swisscom about LPWAN
<https://www.swisscom.ch/en/about/medien/press-releases/2016/03/20160314-MM-Internet-der-Dinge.html>
<http://lpn.swisscom.ch/e/our-offering/>
- [7] Datasheet of SHTC1
<https://www.sensirion.com>
- [8] Datasheet of BME280
<https://www.bosch-sensortec.com>
- [9] Datasheet of ADXL362
<http://www.analog.com>

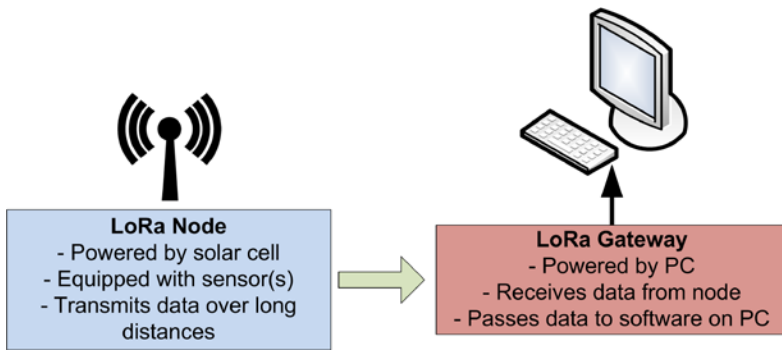

Fig.1 Basic system
Measurements from different nodes are sent to a PC using the LoRa wireless system. Few gateways are required, thanks to the better range of LoRa.

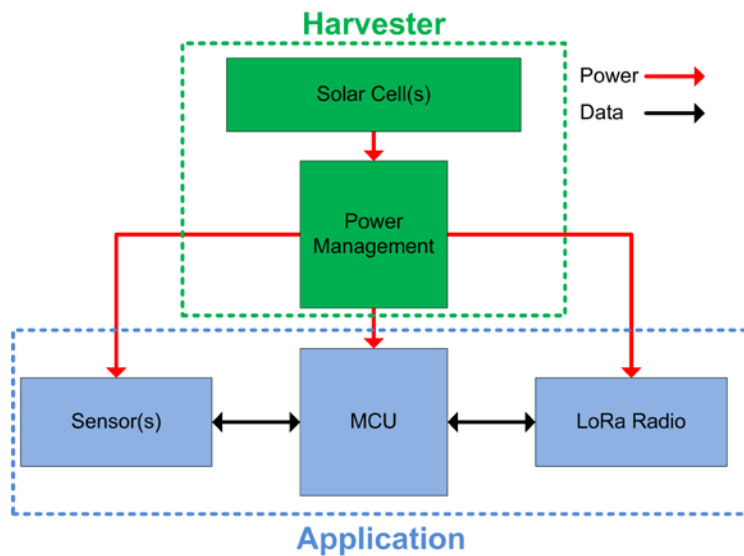
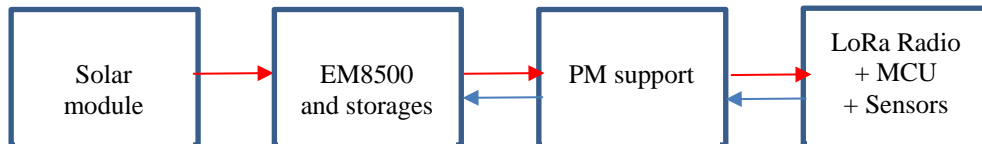

Fig.2 Basic block diagram of the sensing embedded system.
The voltage of the solar cell is boosted and the resulting energy is stored in the LTS (Long Term Storage). Converters and other power management elements are used to provide the needed energy to the ES (Microcontroller + LoRa radio) for processing and transmission.

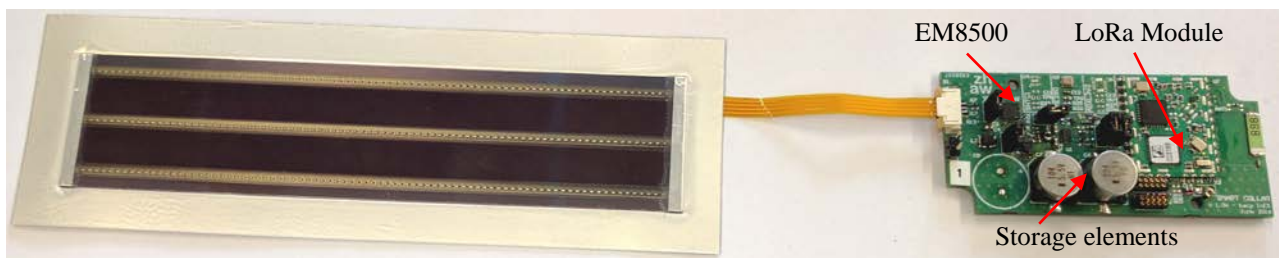

Fig.3. A picture of the embedded system (microcontroller and radio) with an indoor (DSSC) solar cell from GCell. The dimensions of the solar cells are: 167mm x 53mm x 0.5mm (active solar cell area is 140mm x 24 mm) Sensors are from Sensirion, Bosch, Analog Devices. This PCB version with chip antenna

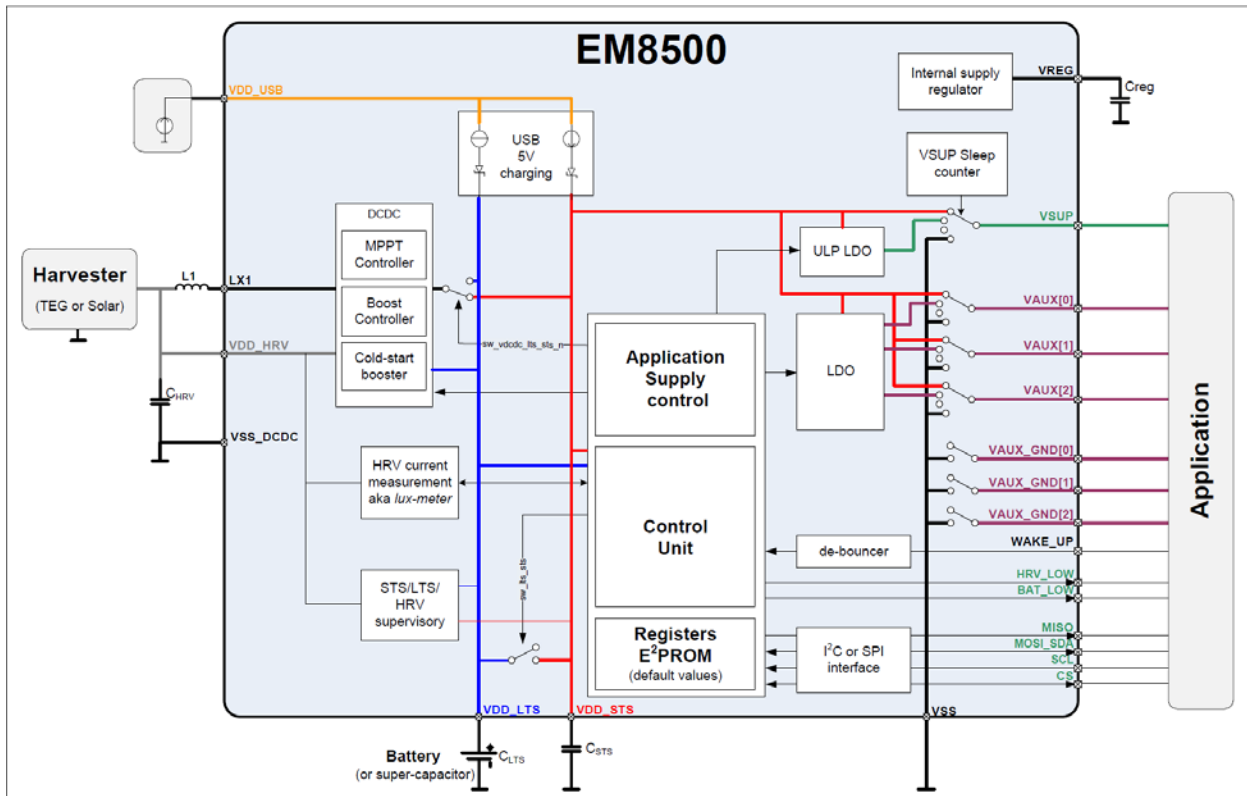

Fig.4 Block diagram of the EM8500. Refer to datasheet for more information [2].

Radio Ctrl Field	Dest. Group Addr	Dest. Device Addr	Source Group Addr	Source Device Addr	Radio Stack Field	Payload: Sensor ID, Temperature, Humidity, Altitude and MCU restart flag
1 Byte	1 Byte	2 Bytes	1 Byte	2 Bytes	1 Byte	14 Bytes

Fig.5 Format of the transmitted frame

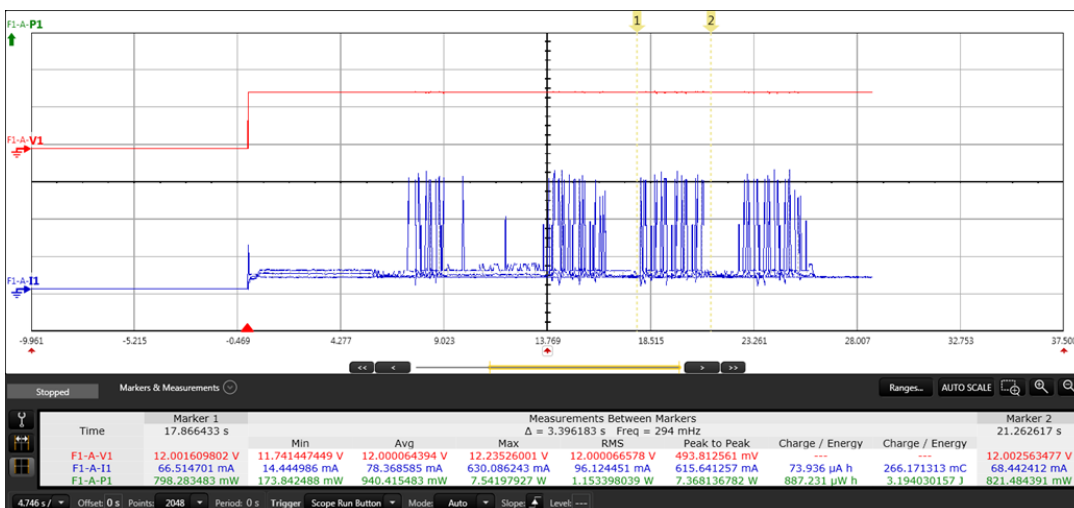

Fig.6 Energy needed to send a message of about 50 character using a GSM modem. More than 3 Joules.

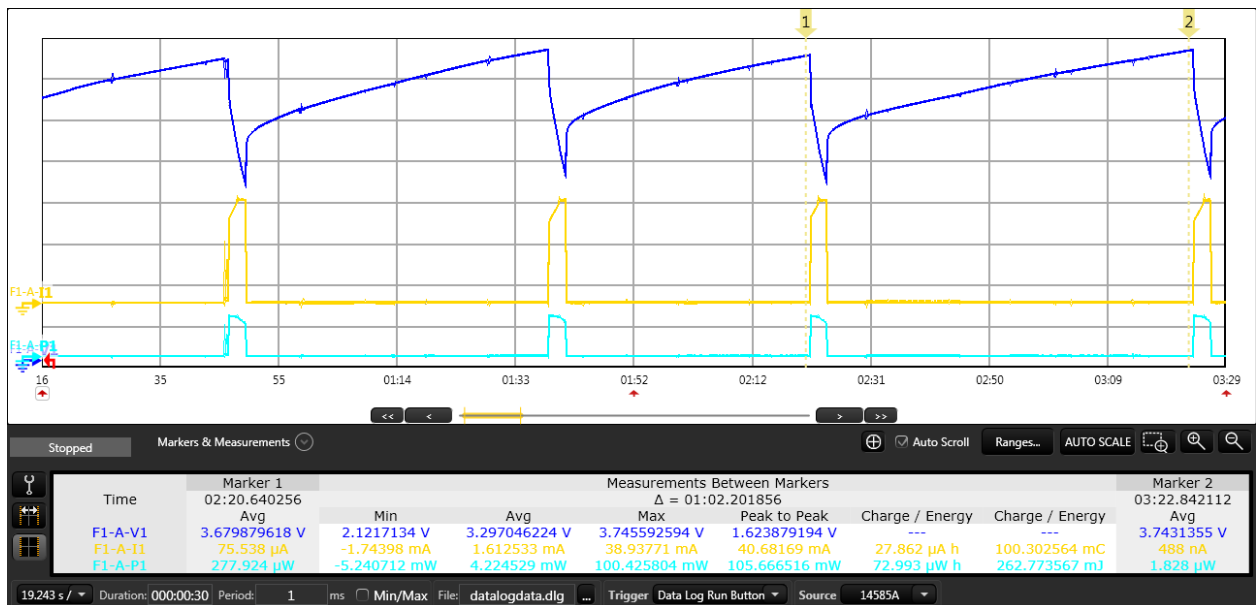

Fig.7 Power profile while transmitting data in SF12 with +14 dBm. 262mJ needed. STS voltage in blue. Current in yellow.

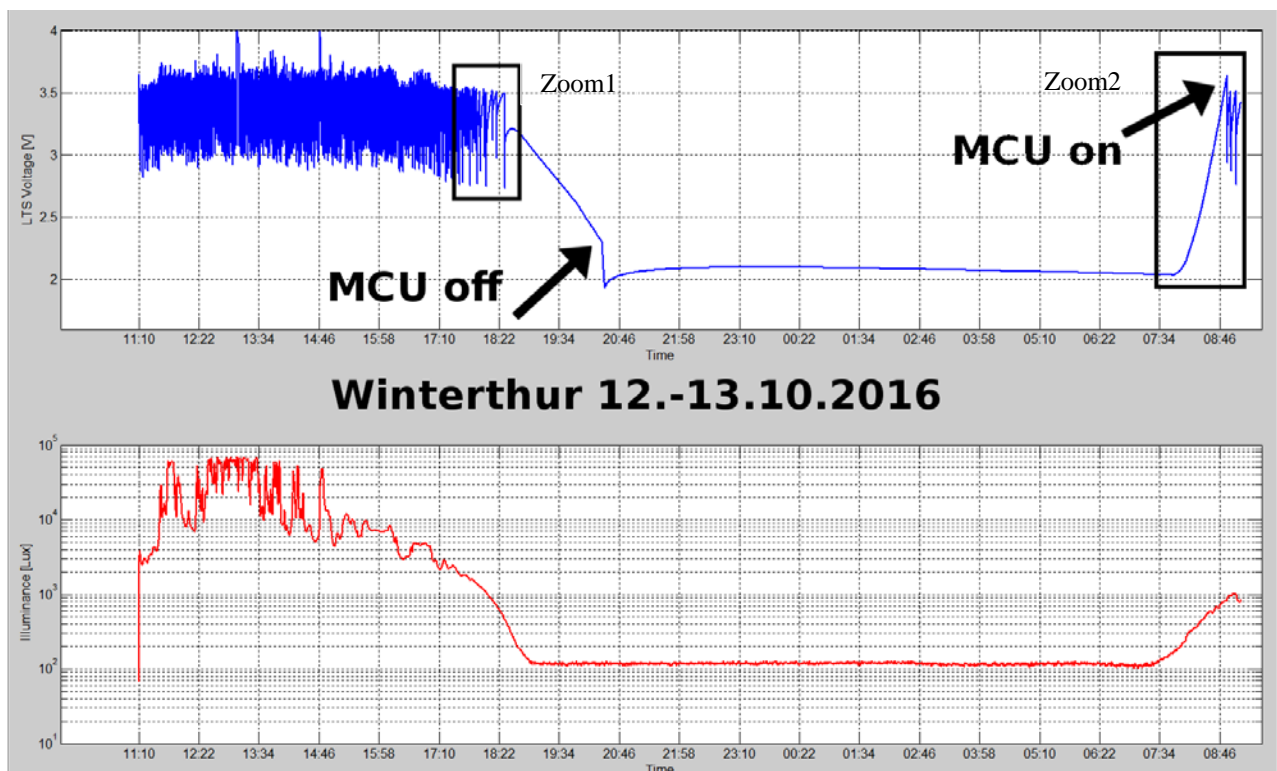

Fig.8 Recording of storage voltage level and transmission activities in function of time of the day. The higher the light intensity, the more transmissions and thus changes of the LTS voltage. Variations on the LTS voltage have to do with the discharge/recharge while transmitting and recharging. This is better seen on the zooms. There are 1013 transmissions in the time interval 11:10 - 18:22 → more than 130 per hour in average
 Conditions: SF10, RF output power = +14dBm, 868MHz, coding rate 4/5, BW=125KHz
 Note: The precision of the illumination measurements in the lower end is poor.

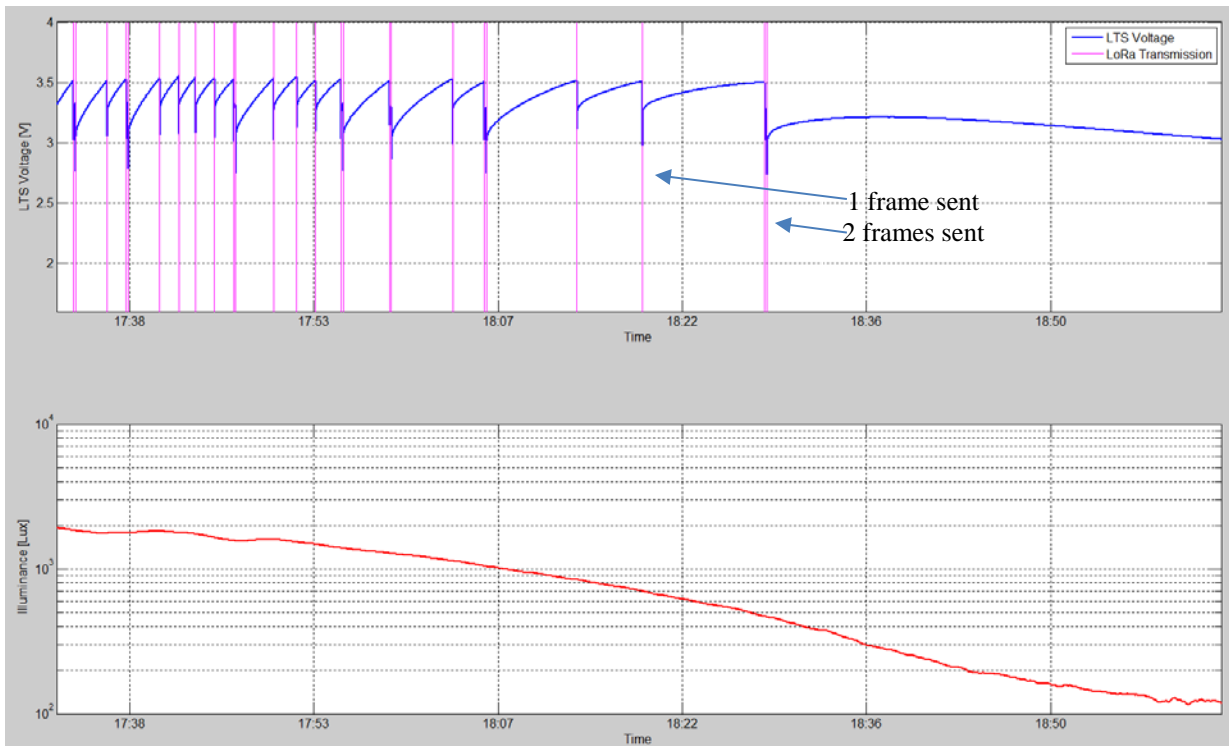

Fig.9 Zoom1 The voltage on the LTS goes down every time a frame is transmitted. Due to a bug, successive frames are sometimes transmitted with 10 seconds interval. Higher illumination means more energy (storage voltage rises faster) and therefore more transmissions.

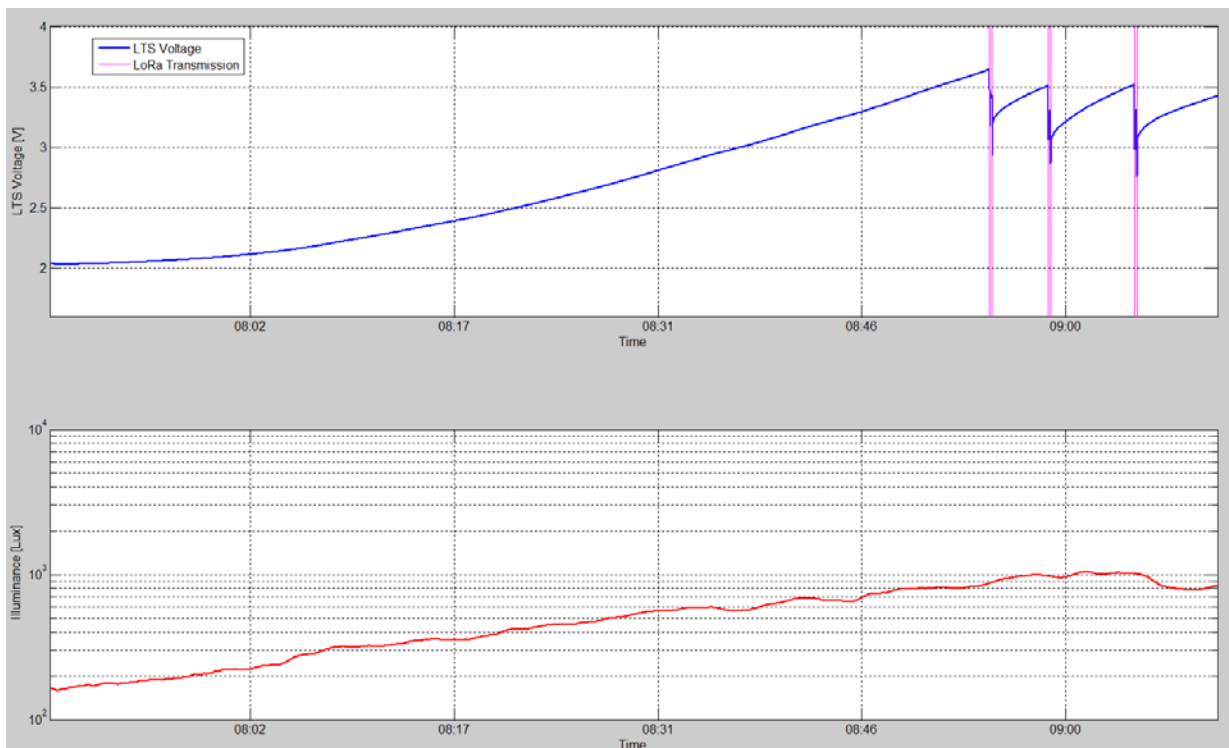

Fig.10 Zoom2 During the night, the storage energy is too low (in this case) to allow any transmission. As the sun rises, energy starts to be accumulated. When there is enough, the embedded system restarts. The system could be dimensioned so that communication is also possible at night, using the stored energy.

Energy Consumption $E(tx\ pwr, n\ Byte, bitrate)$

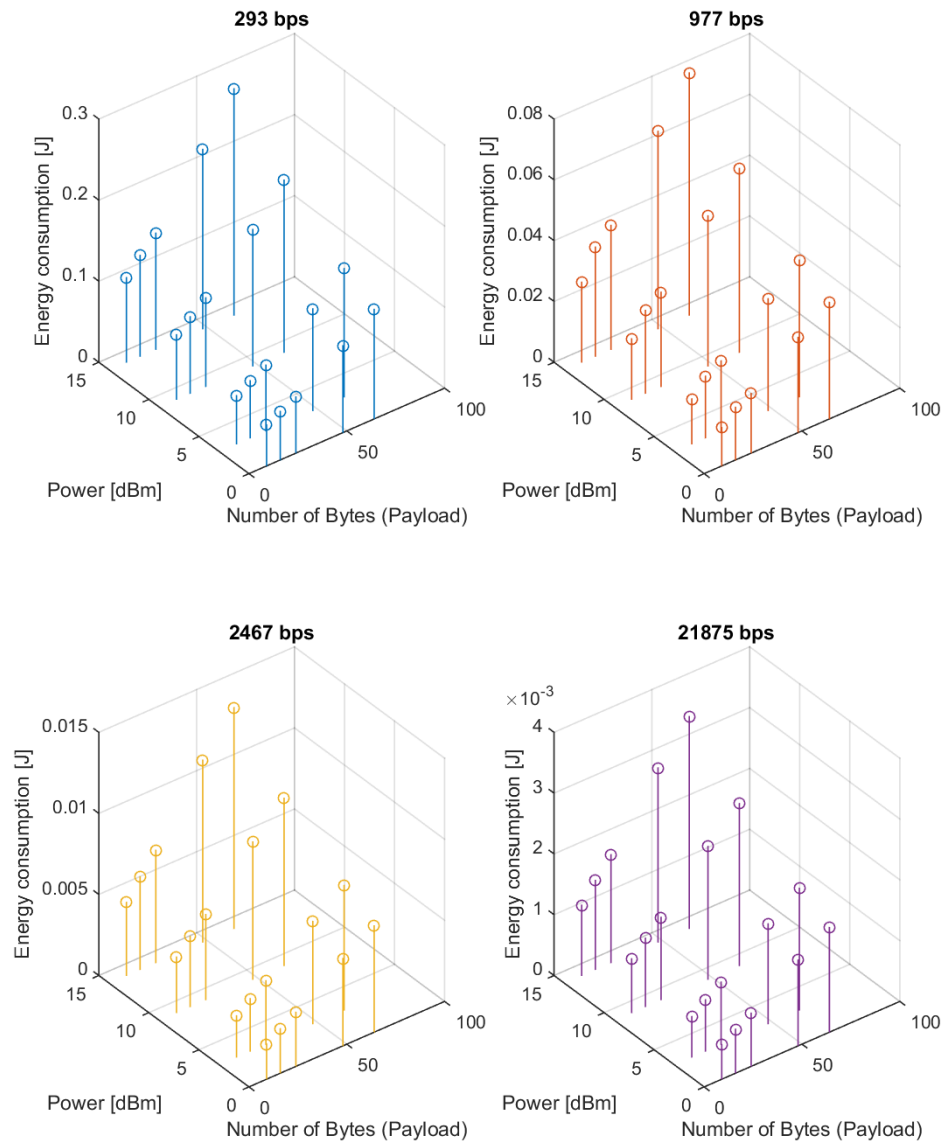

Fig.11 Energy consumption when sending frames of different sizes using LoRa at different baud rates.

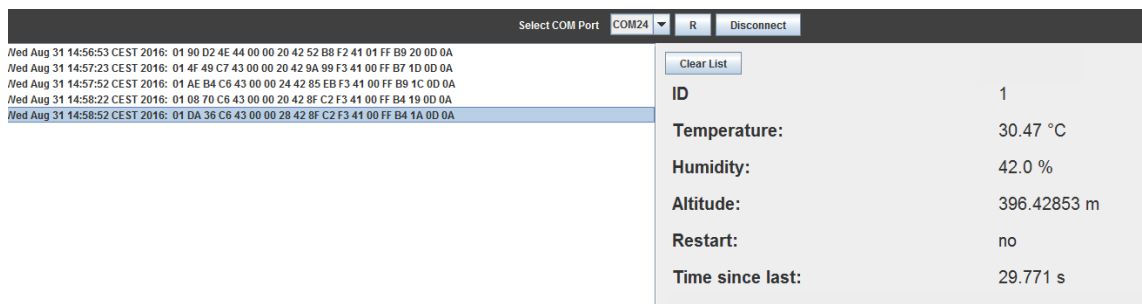

Fig.12 PC screenshot showing some sensing results.