

Advertising position with battery-less Bluetooth Low Energy

Authors:

M. Meli, M. Würth

Contact address:

Prof. Dr. Marcel Meli

Zürcher Hochschule für Angewandte Wissenschaften (ZHAW)

Institute of Embedded Systems (InES)

Technikumstrasse 9

CH-8400, Winterthur, Switzerland

Email : marcel.meli@zhaw.ch

Abstract:

One application of the modern mobile phone is navigation. For instance, a GPS module placed in the mobile phone can be used to inform the user about his position. Coupled with the appropriate maps and information about where to go, the system can be used to lead the user to the right place. There are several places where the GPS signal is not available (or say not strong enough), and the position information is missing. In this work, we present a low cost tag that can be used to broadcast GPS coordinates (and other valuable information) using the new Bluetooth Low Energy wireless standard, particularly in places where the GPS signal is too weak. The low cost wireless embedded system is built using very low power communication concepts. Contrary to other similar devices, it can run on harvested energy, eliminating the need of a battery and therefore strongly reducing maintenance needs. The tag makes use of Ble ADV frames, resulting in a very simple system with low memory requirements. The pre-programmed coordinates of a given location can be sent on 1 or on all the 3 advertising channels of Ble using energy harvested from the environment light with a small solar cell. All this results in a very low cost active Ble tag, powered with energy harvesting.

1. Introduction

One important application of a mobile phone today is navigation. For example, a GPS module placed in the mobile phone is used to inform the user about his position. However, there are several places where the GPS signal is too weak to be useful. This is true for instance for public places that are built underground, large multi-storey buildings ...etc. In such cases, the user needs to rely on other methods for navigation, unless the position information can be made available to the navigation tool in other ways.

Several methods have been suggested to allow indoors navigation. Descriptions can be found in appropriate papers regarding RF fingerprinting, use of active WPAN tags, use of Ble and Direction of Departure (DoD) [8,16,17]. Range considerations are also found in these documents.

For indicating a position, one can use tags (active RFID) placed at specific locations, that constantly broadcast their GPS position. To avoid using a special device for navigation, the data broadcasted should be accessible to the navigation application on some consumer platform such as mobile phones. For this to be possible, it is important to use a communication channel that is already available on the mobile phone (wireless LAN, BT, ...). Since there are likely to be several tags broadcasting their coordinates, the problem of cost and maintenance (especially energy) must be addressed. The method used in this work

differs from others by the use of tags that can directly work with a wireless system that is integrated in the mobile phone and are powered using energy harvested from the surroundings (no batteries).

The design presented relies on the new Ble communication stack, expected to soon be available in many mobile telephones. Its low power features and low cost make it suitable for low cost active tagging.

As mentioned earlier, several groups are also targeting the use of Ble for similar applications. In order to power the tags, small CR2032 coin batteries are foreseen. The design is made to draw as little energy as possible, in order to allow the batteries to last several years.

However, the batteries will still have to be changed, which can result in logistics issues if many of the tags are used at different places in a building. In cases where mains power is used, one may rule out certain areas of a building where there is no mains outlet.

This work builds on a work presented earlier [15] where a similar system was used to measure relative humidity and temperature. For that reason, the 2 papers show many similarities.

2. The design

A tag was designed that is capable of holding location data (in a non-volatile memory). The tag should be small, cheap and be powered by a small solar cell. It should be able to harvest energy from the ambient light and send the location data on 1 to 3 ADV channels, with different power requirements, several times per minute (considering that people are walking).

2.1. Hardware

Figure 1 shows the blocks needed in the application. A DUAL interface RFID tag can be used to program the coordinates

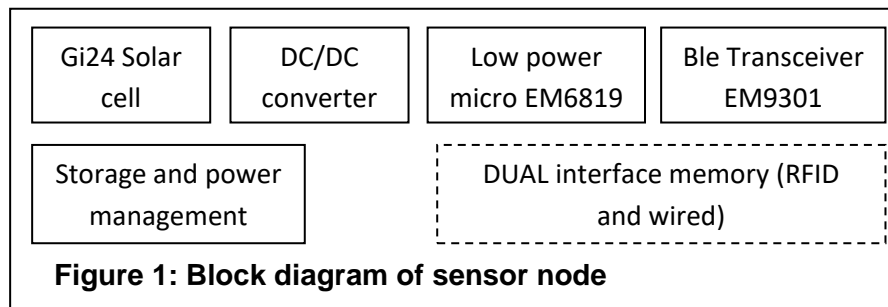

that should be broadcasted. These will then be read when needed and transmitted.

An important step in designing for low energy is the choice of appropriate components. The elements of the sensor are chosen to use a minimum amount of energy in order to send the messages. The energy comes from a small solar cell often illuminated by artificial light (building luminosity conditions). Components are also selected to keep costs down. The different components will now be described.

EM9301 [5,10]

The EM9301 is used in this application to transmit Ble radio frames to host stations. It is a single-mode Master/Slave controller, optimized for low voltage and low energy systems such as

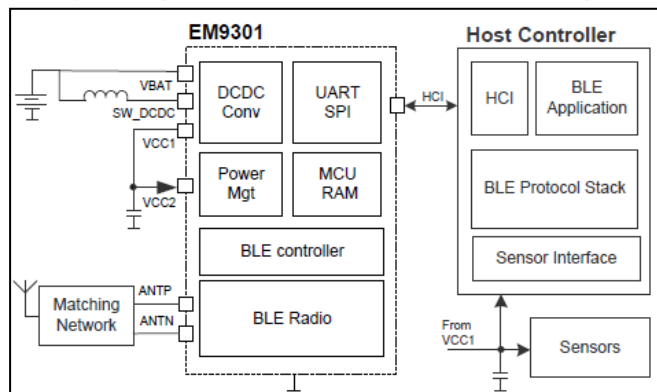

Embedded World Conference, Nu **Figure 2: EM9301-based system**

wireless sensors, wireless remote controls and wireless monitoring. With operating supply voltage as low as 0.8V, the circuit allows applications to take advantage of a wide range of common single-cell batteries or of energy harvesters such as solar cells, piezo-electric and electro-magnetic elements. The output power can be programmed between -20dBm and +4 dBm. The device typically needs 14.5 mA in active mode (radio in Tx).

EM6819 [14]

This microcontroller is based on the 8-bit CoolRISC CPU. It can start as low as 0.9 volt, and consumes around 140 μ A @ 1MIPS, 3 volts. It is used in this application to control the the radio. Its low energy timer can also be used to schedule events.

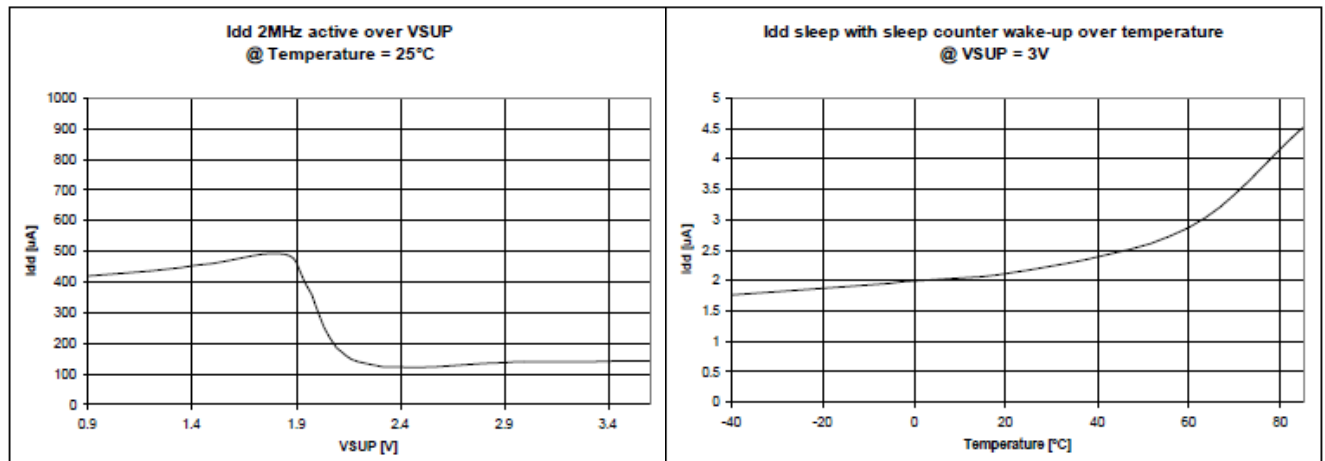

Figure 3: current consumption of the microcontroller

Solar Cell [12]

Several solar cells were tested, in particular those of the firm G24i.

An effort was made to use small cells to keep costs and space needs down. The Indy2050 is used for the measurements shown in this work. It measures 35mm x 50mm. Its important parameters are shown in Table 1.

Parameter	Symbol	Condition	Typical	Minimum	Maximum	Units
Open circuit voltage	Voc	200 lux	1.12	1.10	1.13	V
		1000 lux	1.25	1.24	1.27	
Short circuit current	Isc	200 lux	57	52	63	μ A
		1000 lux	253	242	265	
Operating voltage	Vop	200 lux	0.89	0.87	0.91	V
		1000lux	1.00	0.97	1.03	
Operating current	Iop	200 lux	51	46	55	μ A
		1000 lux	228	215	241	
Bend radius	Br	-	30	-	-	mm
Thickness	d	-	0.35	-	-	mm
Mass	M	-	592	-	-	gm ²

Table 1: Important parameters of the Indy2050 solar cell

Voltage conversion and energy management.

This block is responsible for delivering a voltage that is high enough for the electronics to function properly until the coordinates are broadcasted. It consists of a DC/DC converter circuit, followed by a voltage monitor and a capacitor for storing the energy. The step-up

allows the use of a minimum number of solar cells. This contributes in keeping costs low. The voltage monitor circuit allows the embedded system to be started only if enough energy has been accumulated to send data on the appropriate channels. The capacitor has to be chosen such as to allow the system to work well within the limits given by the manufacturers.

A solution based on a device that starts up early and manages the storage is possible for this block. This will come in form of a special converter combined with a storage management device, or a low power microcontroller (state machine) that can start on little energy and implement the needed control functions.

In our system, 0.3 volt delivered by one solar cell is enough to start up the voltage converter and store energy. A timer could also be used (in the EM6819 or with an external low power RTC) to time the activities. More information can be found in works done earlier [13].

Optimisation and costs

The system is very simple, which should also be reflected in the costs. Near the low power radio and microcontroller, a small solar cell, an appropriate DC/DC converter and power management is all that is needed. In order to facilitate the programming of the coordinates to be broadcasted, a dual interface RFID device can be used. This will allow the programming of the information with tools such as mobile phone equipped with NFC reader. Data is read by the microcontroller via a serial interface.

An optimized version will eliminate the external microcontroller and reduce the size of the radio software stack (memory resources) since it is only needed to send ADV frames and do some basic housekeeping. This will further reduce the cost of the system.

In cases where one needs to send data with different power levels (some positioning algorithms use that principle), a serial FRAM can be used as low power and fast non-volatile memory.

2.2. Communication

Ble allows data exchange to take place in “connected” mode or in special ADV mode. In the first case, a connection needs first to be established (the 2 parties “meet” and exchange vital information). This is done using one of the 3 ADV channels. After that, the exchange of data takes place using a data channel.

In the case of the application considered, a peer to peer communication is not really necessary. The coordinates should be “broadcasted” for anyone that needs them.

Propagating data using the ADV channels is more appropriate. This has the added advantage of requiring just one broadcast message, which also helps to keep the communication short and limit energy and computing resources.

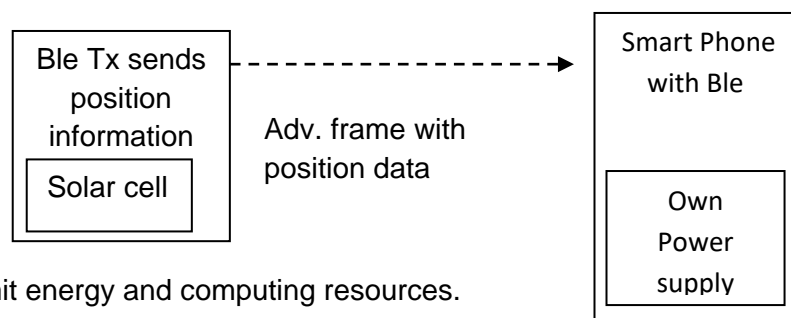

Figure 4: Advertiser of position and host

The elements required in the frame while sending data in advertising mode are shown in Table 2. It is possible to use only 1 channel. This will reduce the energy needs. However, it is preferable to send the data on all 3 ADV channels to facilitate the reception by the mobile phone that scans ADV channels one after the other. This is also good since many public places have several wireless systems that are active (WLAN). More information about the frame format and the timings to meet can be found in the Ble specifications [1].

	lsb						msb
LL packet format	Preamble (1 octet)	Access address (4 octets)	PDU (2 to 39 octets)			CRC (3 octets)	
Access address	10001110100010011011111011010110b (0x8E89BED6) (this is the access address of all adv. Packets)						
Adv. PDU format				Header (16-Bit)	Pload (length in header)		
Header of ADV PDU	PDU type (4 bits)	RFU (2 bits)	TxAdd (1 bit)	RxAdd (1 bit)	Length (6 bits)	RFU (2 bits)	
PDU type ADV_ NONCONN_IND	0100 (b0 ... b3)						
Payload ADV_ NONCONN_IND					ADVA (6 octets)	ADV Data (0-31 octets)	

Table 2: Elements needed in the sent frame

Position coordinates and other useful information that one would like to broadcast can be packed in the AVD Data field. The packet sent is formatted as shown in Table 3.

Format of frame used to send data					
Preamble	Access adr.	Header	ADVA	ADV data	CRC
1 octet	4 octets (0x8E89BED6)	2 octets	6 octets	Coordinates (e.g 16 bytes)	3 octets

Table 3: Final format of the frame

2.3. Software

The software is written to allow an efficient use of energy. It starts and stops different blocks at the right time, in order to make use of sleep and power down modes as often as possible. It should also allow the system to recover/restart properly in case there are energy problem.

The software will control the selection of channels and the timings to respect the specifications. For example, in case only 1 ADV channel is chosen to send data, it should be ensured that minimal time between ADV events is respected.

3. Tests and results

In order to test the design a node was built using the elements described earlier. The node was placed in our office, and programmed to start every time that sufficient energy has been accumulated to be able to transmit data. As receiving station, a Ble node based on the CC2540 device from Texas Instruments running the Ble protocol in a sniffer mode was used. Sniffed data were displayed on a personal computer. Various telephones with Ble stack were also used to visualise the broadcasted information. The tag node was used in different illumination conditions. Data from the tag node was transmitted using 1 or 3 advertisement channels, and the receivers set accordingly

3.1. Energy profile

Figure 5 shows the dynamic energy profile of the active tag.

The system current and the voltage are shown over the time. Since the energy is first accumulated in a capacitor before starting, the voltage progressively decreases as the capacitor is emptied.

The total energy used by the system depends on parameters such as the number of sent bytes and the number of channels used.

When the system starts, the decoupling capacitors are first charged, leading to a peak in the current. The microcontroller and the radio that are directly connected to VDD also start up. After the POR, the EM6819 microcontroller boots up, initialises the radio (channel, output power ...etc.), loads the coordinates, gives the order to send data. If more than 1 channel is used, the order to select another channel is given and data sent. The communication between the microcontroller and the radio is done over the HCI interface.

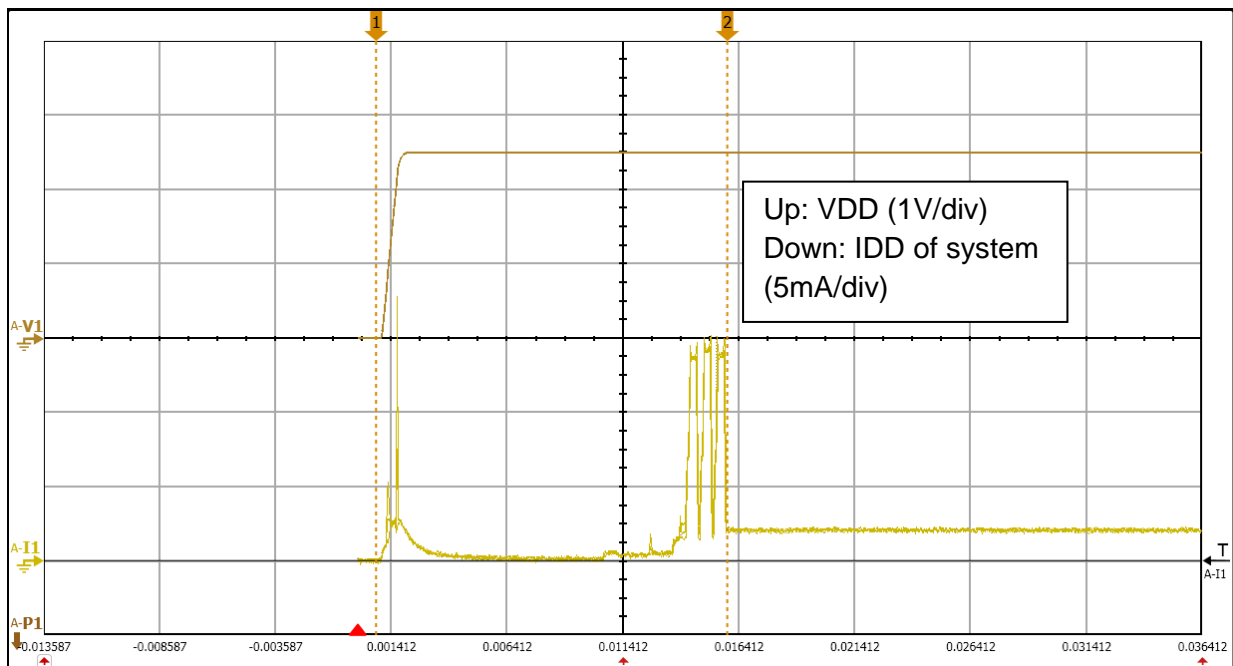

**Figure 5: At VDD= 2.5 volt, load of 24 bytes per channel, 0dBm, 3 channels
Total energy ~ 60 μ J**

3.2. Receiving data on advertisement channels

A Ble scanner (such as a mobile phone) will scan all 3 Ble ADV channels, one after the other, looking for devices that are broadcasting.

If the scanner is exactly on the same channel as the tag when it is advertising, and in the proper range, the ADV signal will be seen, and the scanner can read the data, interpret them, and measure the RSSI signal.

If the scanner and the tag are not on the same channel, or too far away from one another, the tag will not be seen.

By broadcasting on all 3 channels, there is a higher probability for scanner and tag to find each other (if they are within range). The system will also be less prone to interference, especially in a building where WLAN is active (or another wireless systems working in the 2.4 GHz band).

If the receiver is made to scan all the 3 advertisement channels, about one third of the messages are received. Alternatively, one could always broadcast on the same channel, which will increase the number of frames sent on that channel for a given amount of harvested power. However, this could lead to a higher susceptibility to interferences.

P.nbr.	Time (ms)	Channel	Access Address	Adv PDU Type	Adv PDU Header
					Type TxAdd RxAdd PDU-Length
1	+0 =0	0x25	0x8E89BED6	ADV_NON_CONN_IND	2 0 0 22
2	+8304 =8304	0x25	0x8E89BED6	ADV_NON_CONN_IND	2 0 0 22
3	+8197 =16502	0x25	0x8E89BED6	ADV_NON_CONN_IND	2 0 0 22
4	+8087 =24589	0x25	0x8E89BED6	ADV_NON_CONN_IND	2 0 0 22

AdvA	AdvData	CRC	RSSI (dBm)	FCS
0xFF3456789ABC	EF BE AD DE EF BE AD DE 78 03 34 12 EF BE AD DE	0xA4C642	-47	OK
0xFF3456789ABC	EF BE AD DE EF BE AD DE 78 03 34 12 EF BE AD DE	0xA4C642	-47	OK
0xFF3456789ABC	EF BE AD DE EF BE AD DE 78 03 34 12 EF BE AD DE	0xA4C642	-47	OK
0xFF3456789ABC	EF BE AD DE EF BE AD DE 78 03 34 12 EF BE AD DE	0xA4C642	-48	OK

Figure 6 : Data sent by tags was captured using a sniffer. The field “AdvData” shows data in hexadecimal. Data is sent every 8 seconds (depends on luminosity)

Conclusions and future work

Ble tags can be powered with solar cells in a room or building environment, in order to broadcast pre-programmed information such as coordinates. By using the ADV mode, packets can be sent with little energy, allowing tags to be powered with small solar cells. Furthermore, the software can be so written that only a small program is needed (no full Ble stack), leading to further costs savings. The energy needs of the embedded system described here is so small (less than 54 μJ for 3 channels and a pload of 16 bytes, 0dBm) that it is possible for the tags to broadcast their position on all 3 ADV channels every 8 seconds in a room where the luminosity is 400 Lux..

These coordinates can be used in several ways to enable navigation (see references).

In a future work, we will use this tag to implement and test different navigation concepts.

A discussion about range issues can be found in referenced documents

Acknowledgements

We wish to express our thanks to the following firms for their help and support:

- EM Microelectronic Marin, Switzerland for providing microcontrollers and Ble radios
- G24i in Wales for providing solar cell samples.

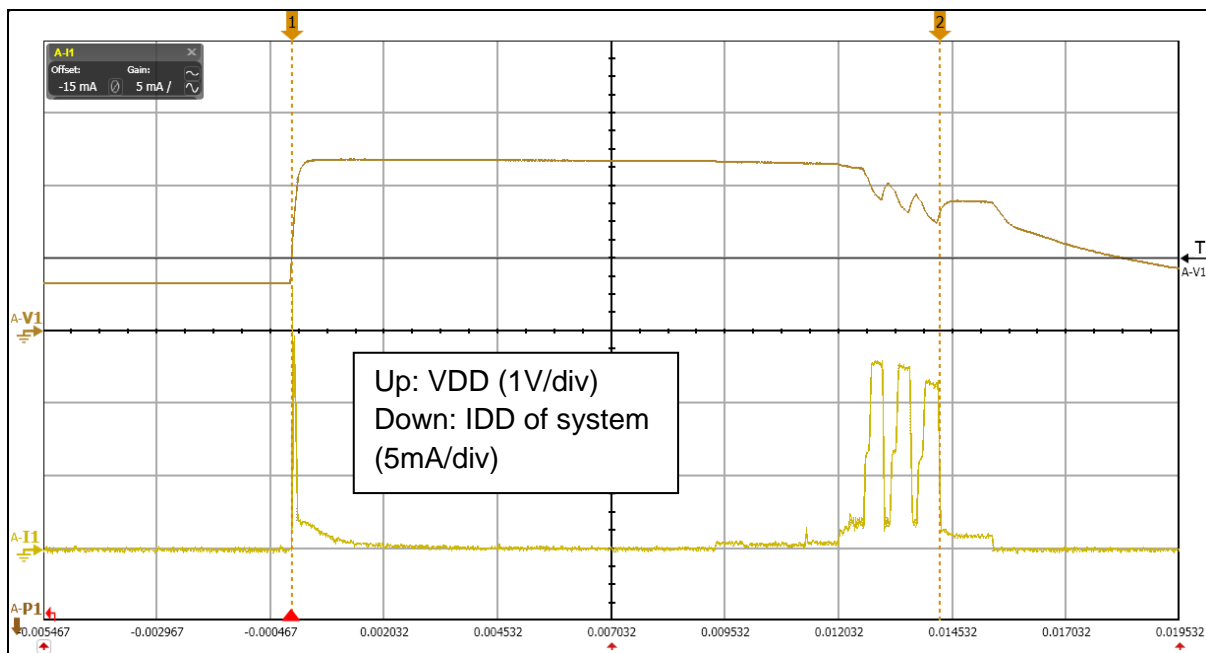
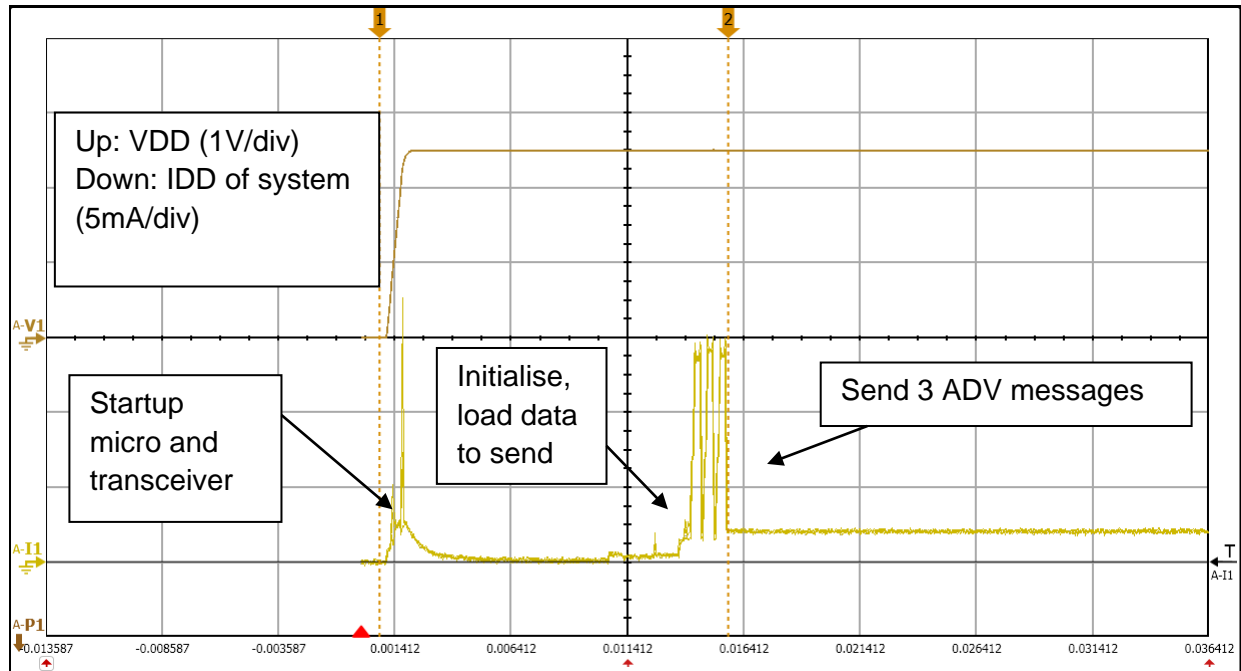

Figure 7. Power profile of the system powered using the solar cell and DC/DC converter. It can be clearly seen how the system voltage goes down as the storage is emptied. Care should be taken for the voltage to be high enough for all the packets.

Figures 8 a,b,c Energy consumption of the embedded system

Constant power supply of 2.5 volts and RF output power of 0dBm. For the ADV packets used, overhead = 16 bytes, total bytes sent = 16 bytes + pload (per channel)



a) Pload = 16 bytes, Data sent on all 3 ADV channels, one after the other. Total energy needed is ~54 μ J

P.nbr.	Time (ms)	Channel	Access Address	Adv PDU Type	Type
1	+0 =0	0x27	0x8E89BED6	ADV_NON_CONN_IND	2

Adv PDU Header				AdvA	AdvData	CRC	RSSI (dBm)	FCS
Type	TxAdd	RxAdd	PDU-Length	0xFF3456789ABC	EF BE AD DE EF BE AD DE 78 03 34 12 EF BE AD DE	0xA4C642	-46	OK
2	0	0	22					

Frame as seen on one channel

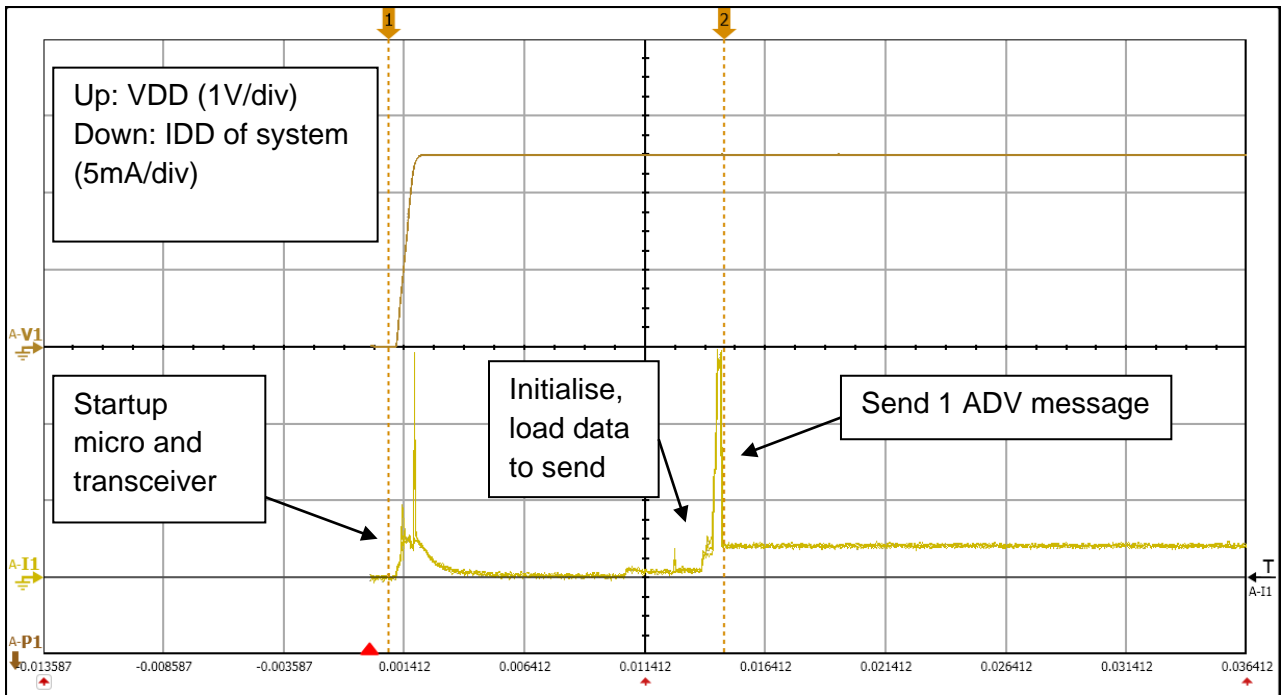

b) Data sent on 1 ADV channel with stable power supply. Pload = 8 bytes. Total energy from power on until data is sent is ~ 25 μ J

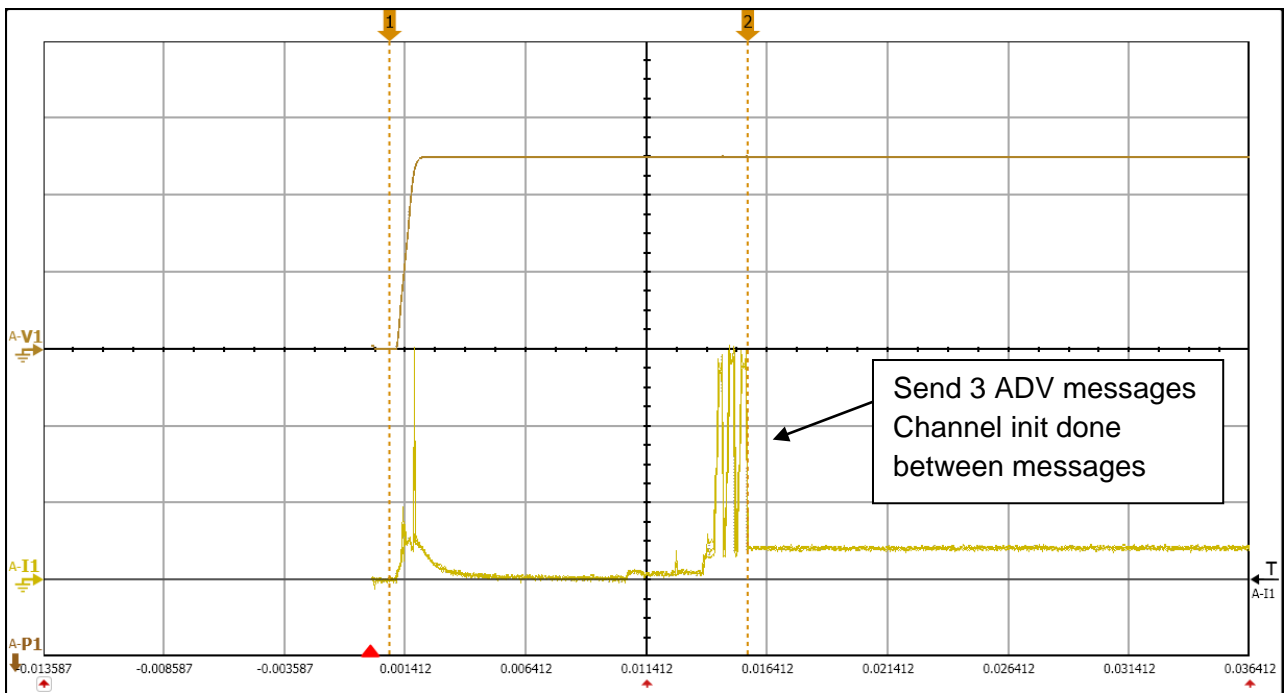

c) Data sent on 3 ADV channels with stable power supply. Pload = 8 bytes, VDD = 2.5 Volts, RF send power = 0dBm. Total energy from power on until data is sent is ~ 48 μ J

Indoors tests with the G24i solar cell.

Figures 9 a,b,c show how fast the embedded system reacts depending on luminosity (Embedded system voltage against time).

Energy is first accumulated and voltage boosted. When the voltage is high enough (enough energy), the embedded system is started. A message is sent. The voltage drops, and a comparator switches the embedded system off. The message is sent on 1 channel, or on all 3 ADV channels. The power management and software should be designed accordingly.

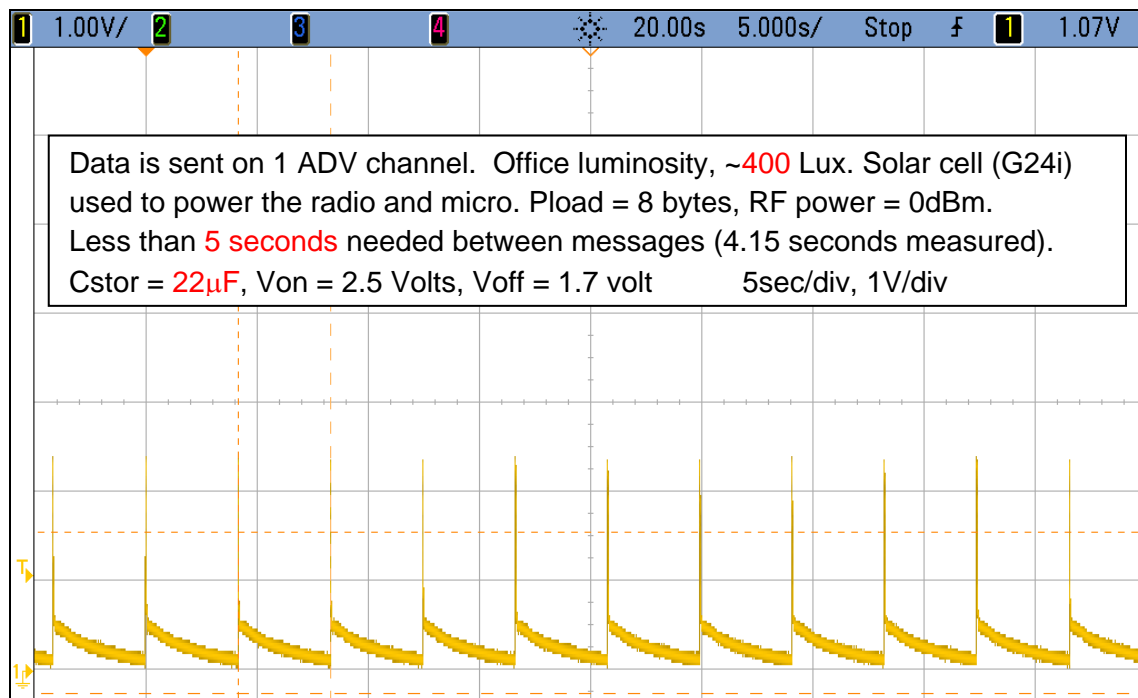

a) Office luminosity at 400 Lux

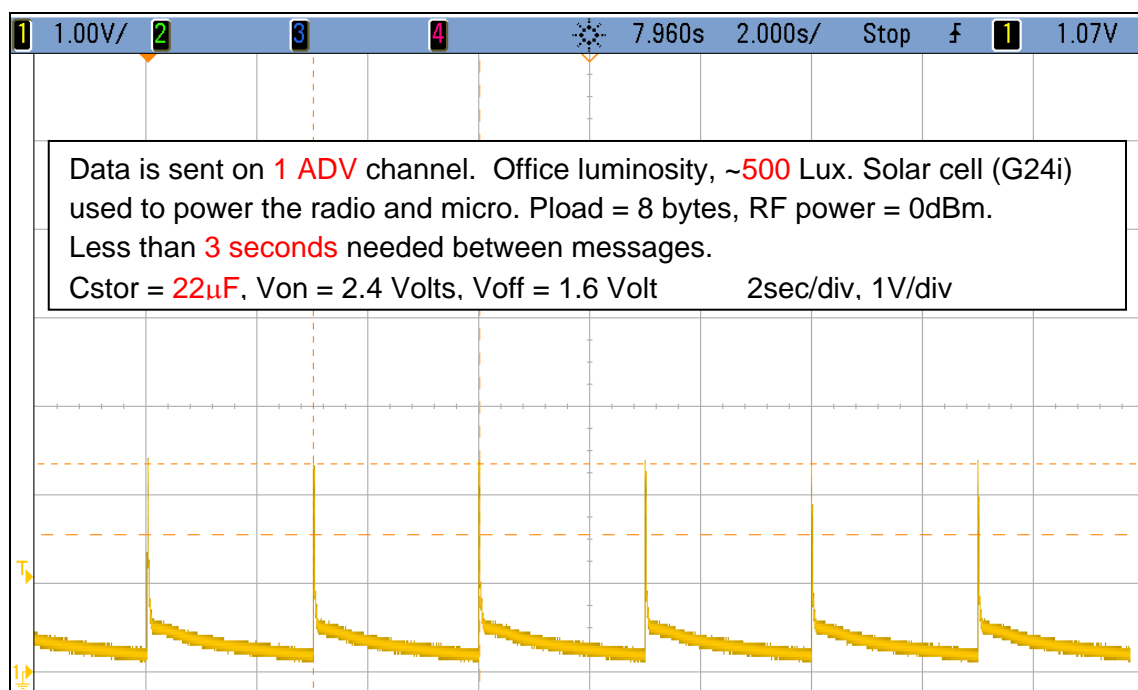

b) Office luminosity at 500 Lux

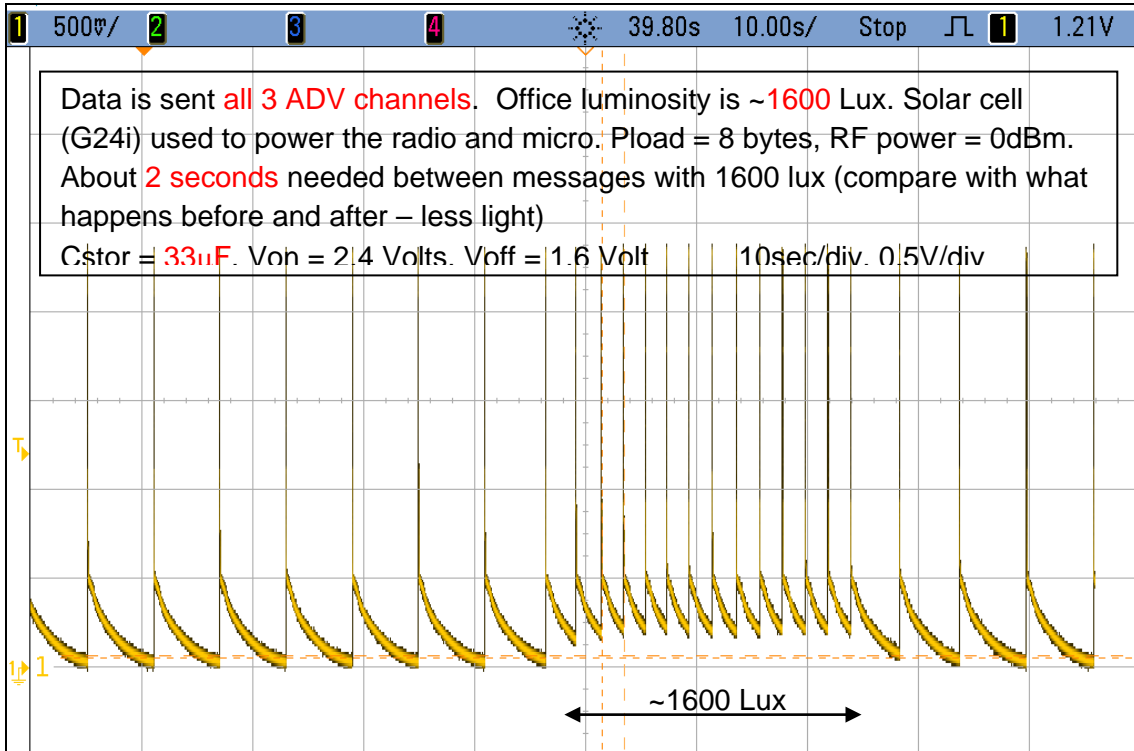

c) Office luminosity at 1600 Lux, message sent on all 3 ADV channels

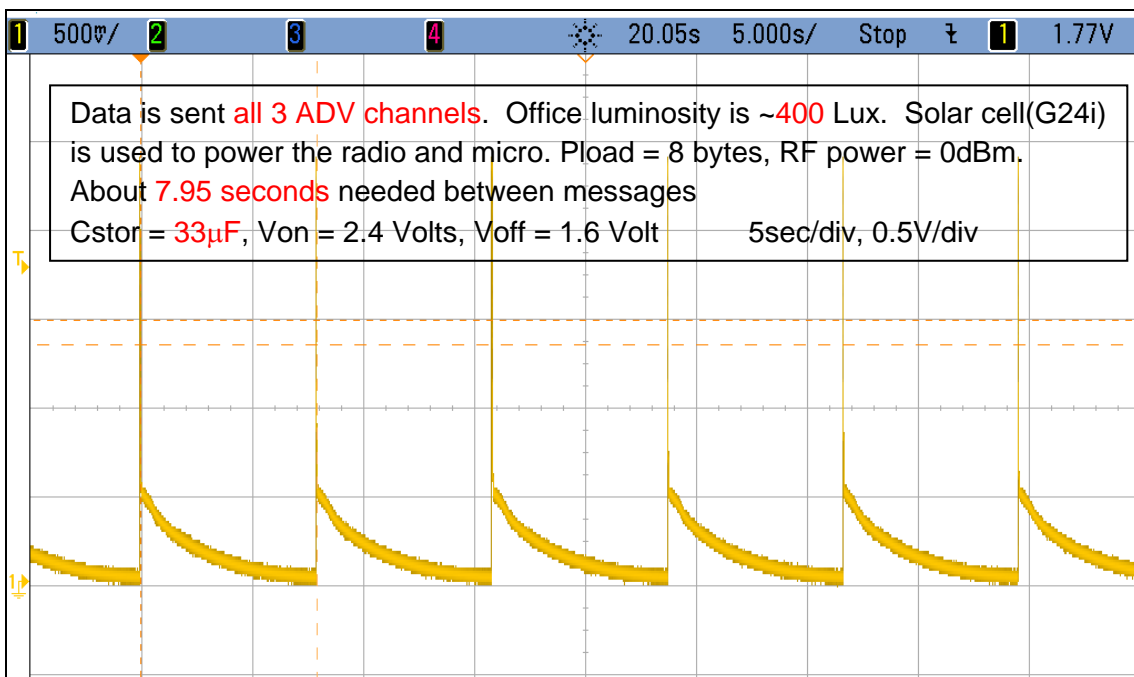

d) Office luminosity at 400 Lux, message sent on all 3 channels

By properly dimensioning the energy management system (threshold values, solar cell size ...etc.) one could send messages fast enough to enable a navigation application to run smoothly.

References.

- [1] Ble specifications V 4.0, June 2010
<https://www.bluetooth.org/Technical/Specifications/adopted.htm>
- [2] Bluetooth SIG www.bluetooth.org
- [3] A battery-less switch for use in 802.15.4 / ZigBee applications
M. Meli, A. Bluem, M. Gysel. Second European Developer's ZigBee Conference.
Munich June 2009
- [4] Bidirectional 868/915 MHz wireless module powered with energy harvester.
M. Meli, S. Blättler, V. Kunz, M. Gysel
10. Wireless Technologies Kongress, September 2008, Bochum
- [5] EM9301 factsheet. http://www.emmarin.com/webfiles/product/other/EM9301_FS.pdf
- [6] EnOcean: www.enocean.com
- [7] lightningswitch: www.lightningswitch.com
- [8] High Accuracy Indoor Positioning Based on BLE, Kimmo Kalliola, Nokia.
www.hermia.fi
- [9] Battery-less wireless Switch with EM9201. www.ines.zhaw.ch
- [10] Datasheet and development tools for CC2540. www.ti.com
- [11] EM news about the EM9301. <http://www.emmarin.com/DetailNews.asp?IdNews=123>
- [12] Indy2050 solar cell datasheet. www.q24i.com
- [13] ZigBee compatible sensor powered by one tiny solar cell
M. Würms, M. Gysel, M. Meli; 4th European ZigBee Conference
Munich April 2010
- [14] EM6819 datasheet.
http://www.emmarin.com/webfiles/product/mcu/ds/EM6819_DS.pdf
- [15] Indoor battery-less temperature and humidity sensor for Bluetooth Low Energy
M. Meli, U. Beerli, Wireless Congress 2011, Munich, 9th November 2011
- [16] Survey of Wireless Indoor Positioning Techniques and Systems
Hui Liu, IEEE TRANSACTIONS ON SYSTEMS, MAN, AND CYBERNETICS—PART
C: APPLICATIONS AND REVIEWS, VOL. 37, NO. 6, NOVEMBER 2007
- [17] Positionsbestimmung mittels Funktechnologien -Vergleich von Verfahren und
Technologien mit exemplarischer Demonstration
Sebastian Gansemer, www.fh-dortmund.de