

Spring 2018

# Stock Price Prediction using Deep Learning

Abhinav Tipirisetty  
*San Jose State University*

Follow this and additional works at: [https://scholarworks.sjsu.edu/etd\\_projects](https://scholarworks.sjsu.edu/etd_projects)

Part of the [Computer Sciences Commons](#)

---

## Recommended Citation

Tipirisetty, Abhinav, "Stock Price Prediction using Deep Learning" (2018). *Master's Projects*. 636.

DOI: <https://doi.org/10.31979/etd.bzmm-36m7>

[https://scholarworks.sjsu.edu/etd\\_projects/636](https://scholarworks.sjsu.edu/etd_projects/636)

This Master's Project is brought to you for free and open access by the Master's Theses and Graduate Research at SJSU ScholarWorks. It has been accepted for inclusion in Master's Projects by an authorized administrator of SJSU ScholarWorks. For more information, please contact [scholarworks@sjsu.edu](mailto:scholarworks@sjsu.edu).

# Stock Price Prediction using Deep Learning

A Project Report

Presented to

Dr. Robert Chun

Department of Computer Science

San Jose State University

In Partial Fulfillment

Of the requirements for the class

CS 298

By

Abhinav Tipirisetty

May 2018

© 2018  
Abhinav Tipirisetty  
ALL RIGHTS RESERVED

The Designated Thesis Committee Approves the Thesis Titled

STOCK PRICE PREDICTION USING DEEP LEARNING

by  
Abhinav Tipirisetty

APPROVED FOR THE DEPARTMENTS OF COMPUTER SCIENCE

SAN JOSÉ STATE UNIVERSITY

May 2018

Dr. Robert Chun Department of Computer Science

Dr. Thomas Austin Department of Computer Science

Vaishampayan Reddy Pathuri eBay Inc.

## **Abstract**

Stock price prediction is one among the complex machine learning problems. It depends on a large number of factors which contribute to changes in the supply and demand. This paper presents the technical analysis of the various strategies proposed in the past, for predicting the price of a stock, and evaluation of a novel approach for the same. Stock prices are represented as time series data and neural networks are trained to learn the patterns from trends. Along with the numerical analysis of the stock trend, this research also considers the textual analysis of it by analyzing the public sentiment from online news sources and blogs. Utilizing both this information, a merged hybrid model is built which can predict the stock trend more accurately.

## **Acknowledgements**

I am grateful and take this opportunity to sincerely thank my thesis advisor, Dr. Robert Chun, for his constant support, invaluable guidance, and encouragement. His work ethic and constant endeavor to achieve perfection have been a great source of inspiration.

I wish to extend my sincere thanks to Dr. Thomas Austin and Mr. Vaishampayan Reddy Pathuri for consenting to be on my defense committee and for providing invaluable suggestions to my project without which this project would not have been successful.

I also would like to thank my friends and family, for their support and encouragement throughout my graduation.

## Table of Contents

<b>Abstract .....</b>	<b>IV</b>
<b>Acknowledgements .....</b>	<b>V</b>
<b>List of tables.....</b>	<b>3</b>
<b>List of figures.....</b>	<b>4</b>
<b>Chapter 1 .....</b>	<b>5</b>
<b>1.1 Introduction .....</b>	<b>5</b>
<b>1.2 Motivation .....</b>	<b>6</b>
<b>Chapter 2 .....</b>	<b>8</b>
<b>2.1 Background .....</b>	<b>8</b>
2.1.1 Supervised Learning .....	8
2.1.2 Unsupervised Learning.....	9
2.1.3 Support Vector Machines.....	9
2.1.4 Deep Learning and Artificial Neural Networks.....	10
2.1.5 Recurrent Neural Network.....	11
2.1.6 Long-short term memory .....	12
<b>2.2 Related Work .....</b>	<b>14</b>
2.2.1 Using stacked auto encoders (SAEs) and long short-term memory (LSTM) .....	14
2.2.2 Integrating Text Mining Approach using Real-Time News:.....	15
2.2.3 Stock Price Prediction using Linear Regression based on Sentiment Analysis .....	15

2.3 Limitations of existing models .....	16
<b>Chapter 3 .....</b>	<b>17</b>
<b>Proposed Approach.....</b>	<b>17</b>
<b>3.1 Numerical Analysis .....</b>	<b>17</b>
Implementation: .....	22
Normalization:.....	23
<b>3.2 Textual Analysis .....</b>	<b>25</b>
Machine Learning Model – Approach 1 - SVM: .....	26
Machine Learning Model – Approach 2 - LSTM: .....	27
<b>3.4 Merged Model .....</b>	<b>32</b>
<b>Chapter 4 .....</b>	<b>34</b>
<b>4.1 Metrics .....</b>	<b>34</b>
Mean Squared Error:.....	34
Accuracy: .....	34
<b>4.1 Experiments on Base Model .....</b>	<b>35</b>
<b>4.2 Experiments on Numerical analysis.....</b>	<b>37</b>
<b>4.3 Experiments on Textual Analysis:.....</b>	<b>40</b>
<b>4.4 Experiments on Merged Model.....</b>	<b>45</b>
<b>Chapter 5 .....</b>	<b>49</b>
<b>Conclusion and Future Work .....</b>	<b>49</b>
<b>References .....</b>	<b>50</b>



## List of tables

Table 1 Sample news headlines and their influence on stock price.....	25
Table 2 SVM model results for prediction using Tech news and Company only news...	44
Table 3 LSTM model results for prediction using Tech news and Company only news.	45

## List of figures

Figure 1 showing the data points represented in a 2D space and the support vector [5]....	9
Figure 2 Feed Forward Neural Network [7] .....	11
Figure 3 Unfolded basic recurrent neural network. [8].....	12
Figure 4 Simple structure of RNNs looping module. [11].....	13
Figure 5 Long short-term memory unit [12].....	13
Figure 6 Sliding window learning the trends in stock price [21].....	18
Figure 7 Unrolled version of the network for Numerical Analysis .....	19
Figure 8 LSTM network architecture for textual analysis .....	27
Figure 9 Convolution of input vector I using filter K [22] .....	29
Figure 10 Convolutional Neural Network for Image Classification [24] .....	29
Figure 11 Convolution of single dimensional vector input [25].....	30
Figure 12 SVM with RBF kernel with Window Size 10 .....	36
Figure 13 SVM with RBF kernel with Window Size 15 .....	36
Figure 14 GOOG LSTM 32 InputSize 1.....	38
Figure 15 GOOG lstm size = 128 and input size = 1 .....	39
Figure 16 input_size=5, lstm_size=128 and max_epoch=75.....	40
Figure 17 News probabilities aligned with same day's prices.....	46
Figure 18 News probabilities aligned with prices 1 day ahead .....	47
Figure 19 Comparison of predictions without news and with news.....	48
Figure 20 Comparison of predictions with baseline model and proposed model.....	48

# Chapter 1

## 1.1 Introduction

Stock price is the price of a single stock among the number of stocks sold by a company listed in public offering. Having stocks of a public company allows you to own a portion of it. Original owners of the company initially sell the stocks to get additional investment to help the company grow. This initial offering of stocks to the public is called Initial Public Offering (IPO).

Stock prices change because of the supply and demand. Suppose, if many people are willing to buy a stock, then the price goes up as there is more demand. If more people are willing to sell the stock, the price goes down as there is more supply than the demand. Though understanding supply and the demand is relatively easy, it is hard to derive what factors exactly contribute to the increase in demand or supply. These factors would generally boil down to socio-economic factors like market behavior, inflation, trends and more importantly, what is positive about the company in the news and what's negative.

Predicting the accurate stock price has been the aim of investors ever since the beginning of the stock market. Millions of dollars worth of trading happens every single day, and every trader hopes to earn profit from his/her investments. Investors who can make right buy and sell decisions will end up in profits. To make right decisions, investors have to judge based on technical analysis, such as company's charts, stock market indices and information from newspapers and microblogs. However, it is difficult for investors to analyze and forecast the market by churning all this information. Therefore, to predict the trends automatically, many Artificial Intelligence (AI) techniques have been investigated [1] [2] [3]. Some of the first research in prediction of stock prices dates back to 1994, in which a comparative study [4] with machine learning regression

models was performed. Since then, many researchers were investing resources to devise strategies for forecasting the price of the stock.

## **1.2 Motivation**

Efficient Market Hypothesis is one of the popular theories in financial economics. Prices of the securities reflect all the information that is already available and it is impossible to outperform the market consistently. There are three variants of Efficient Market Hypothesis (EMH); namely weak form, semi-strong form and the strong form. Weak form states that the securities reflect all the information that is publicly available in the past. Semi Strong form states that the price reflects all the publicly available data and also, they change instantly to reflect the newly available information. The strong form would include even the insider or private information.

But this theory is often disputed and highly controversial. The best example would be investors such as Warren Buffet, who have earned huge profits over long period of time by consistently outperforming the market. Even though predicting the trend of the stock price by manually interpreting the chaotic market data is a tedious task, with the advent of artificial intelligence, big data and increased computational capabilities, automated methods of forecasting the stock prices are becoming feasible. Machine learning models are capable of learning a function by looking at the data without explicitly being programmed. But unfortunately, the time series of a stock is not a function that can be easily mapped. It can be best described more as a random walk, which makes the feature engineering and prediction much harder. With Deep Learning, a branch of machine learning, one can start training using the raw data and the features will be automatically created when neural network learns. Deep Learning

techniques are among those popular methods that have been employed, to identify the stock trend from large amounts of data but until now there is no such algorithm or model which could consistently predict the price of future stock value correctly. Lot of research is going on both in academia and industry on this challenging problem.

## Chapter 2

### 2.1 Background

This section will explain what machine learning is and popular algorithms used by previous researchers to predict stock prices. This will also provide a background of the technologies we use as part of this research.

Machine Learning is a field of Computer Science that gives Computers the ability to learn. There are two main categories of machine learning algorithms. They are Supervised Learning and Unsupervised Learning. The process of training a machine learning model involves providing an algorithm and the data so that model learns its parameters from the provided training data.

#### 2.1.1 Supervised Learning

In supervised learning, we train the machine learning algorithm with a set of input examples and their associated labels. The model tries to approximate the function  $y = f(x)$  as close as possible, where  $x$  is the input example and  $y$  is its label. As we are using a training dataset with correct labels to teach the algorithm, this is called a supervised learning. Supervised learning algorithms are further grouped into regression and classification, based on the output variable. If the output variable is a continuous variable, it is called a regression task. Predicting house price, stock price are examples of regression tasks. If the output variable is categorical variable like color, shape type, etc. it is called a classification task.

In practice, majority of the machine learning applications use supervised learning algorithms. Logistic regression, linear regression, support vector machines and random forests are examples of supervised learning algorithms.

### 2.1.2 Unsupervised Learning

In Unsupervised learning, we train the machine learning algorithm with only the input examples but no output labels. The algorithm tries to learn the underlying structure of the input examples and discover patterns. Unsupervised learning algorithms can be further categorized based on two tasks, namely Clustering and Association. In clustering, an algorithm like k-means tries to discover inherent clusters or groups in the data. In association rule mining, algorithms like apriority tries to predict the future purchase behaviors of customers.

### 2.1.3 Support Vector Machines

SVM belongs to the class of supervised algorithms in machine learning, which relies on statistics. It can be used for both regression and classification tasks. In SVM, we plot each point in the dataset in an n-dimensional space, where each dimension corresponds to a feature. Value of the data point for that feature will represent the location on the corresponding axis. During training, SVM separates the set of labeled input examples by an optimal hyperplane. During testing, the class of the unlabeled data point is determined by plotting it and checking which side the new point is to the hyperplane.

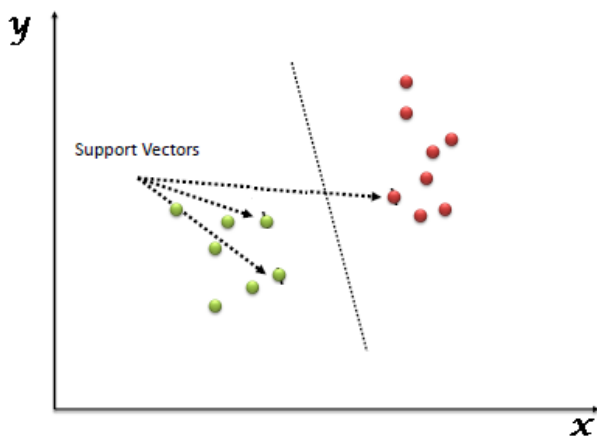

Figure 1 showing the data points represented in a 2D space and the support vector [5]

Lin et al. [6] proposed a stock market forecast system based on SVM. This model is capable of choosing a decent subset of features, controlling over fitting and assessing stock indicator. This research is based on the stock market datasets of Taiwan and this model resulted in better performance than the traditional forecast system.

A significant problem while using SVM is that, the input variables may lie in a very high dimensional space. Especially when the dimensions of the features ranges from hundreds to thousands, training the model requires huge computation and memory.

#### **2.1.4 Deep Learning and Artificial Neural Networks**

Deep learning is part of a broader family of ML methods based on learning data representations, as opposed to task specific algorithms. Deep learning models use a cascade of multi layered non-linear processing units called as neurons, which can perform feature extraction and transformation automatically. The network of such neurons is called an Artificial Neural Network.

Artificial Neural Networks(ANN) are an example for non-parametric representation of information in which the outcome is a nonlinear function of the input variables. ANN is an interconnected group of nodes which simulate the structure of neurons present in the human brain. These neurons are organized in the form of consecutive layers, where output of the current layer of neurons is passed to the successive layer as the input. If the interconnections between the layers of neurons do not form a cycle, that neural network is called a feed forward neural network. In a feed forward neural network, each layer applies a function on the previous layer's output. The hidden layer transforms its inputs into something that output layer can use and the output layer applies activations on its inputs for final predictions.



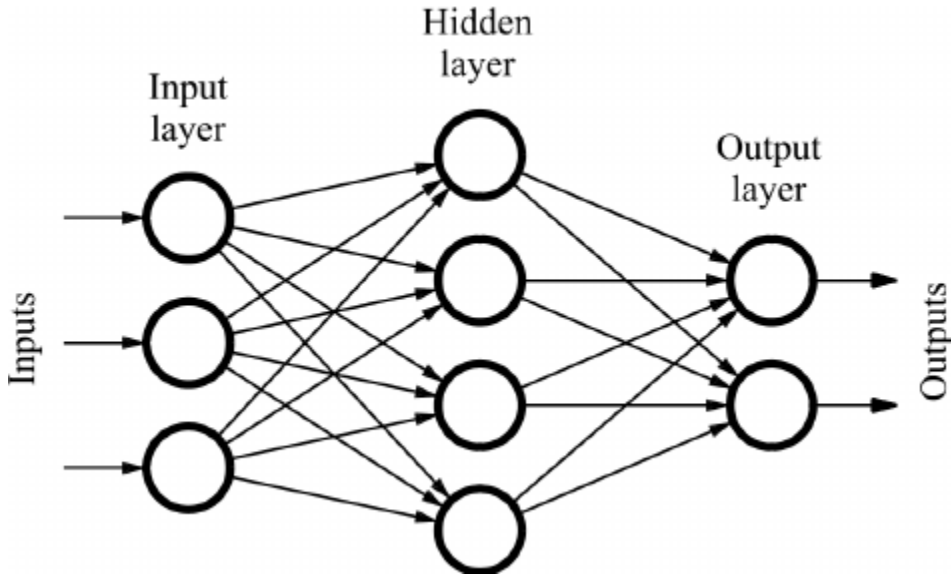

Figure 2 Feed Forward Neural Network [7]

### 2.1.5 Recurrent Neural Network

Recurrent Neural Network (RNN) is a class of ANN in which connections between the neurons form a directed graph, or in simpler words, having a self-loop in the hidden layers. This helps RNNs to utilize the previous state of the hidden neurons to learn current state. Along with the current input example, RNNs take the information they have learnt previously in time. They use internal state or memory to learn sequential information. This enables them to learn a variety of tasks such as handwriting recognition, speech recognition, etc.

In a traditional neural net, all input vector units are assumed to be independent. As a result, sequential information cannot be made use of in the traditional neural network. But whereas in the RNN model, sequential data of the time series generates a hidden state and is added with the output of network dependent on hidden state. As the stock trends are an example of a time series data, this use case is a best fit for RNNs. The following figure shows an RNN model expanded into a complete network.

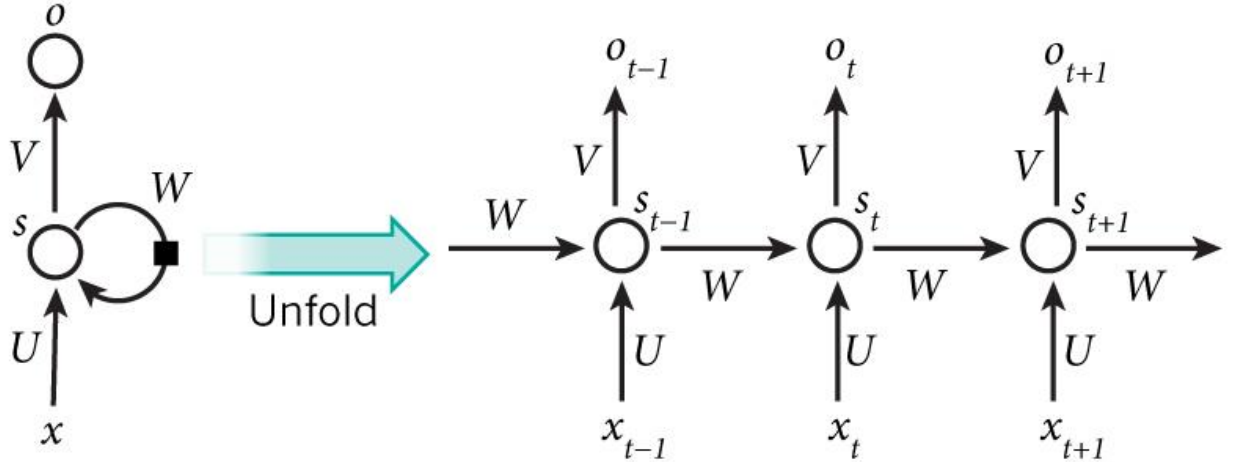

Figure 3 Unfolded basic recurrent neural network. [8]

Based on the outcome of the output layer, updates to the weights of hidden layers are propagated back. But in deep neural networks, this change will be vanishingly small to the layers in the beginning, preventing the weights to change its value and stopping the network to learn further. This is called vanishing gradient problem [9].

### 2.1.6 Long-short term memory

Long short-term memory (LSTM) is a type of recurrent neural-network architecture in which the vanishing gradient problem is solved. LSTMs are capable of learning very long-term dependencies and they work tremendously well on a large variety of problems. LSTMs are first introduced by Hochreiter et al. in 1997 [10]. In addition to the original authors, many researchers contributed to the architecture of modern LSTM cells.

Recurrent neural networks are generally designed in a chain like structure, looping back to the previous layers. In standard RNNs, this looping module will have a very simple structure, as shown in the Figure 4. This structure can be a simple tanh layer controlling the flow.

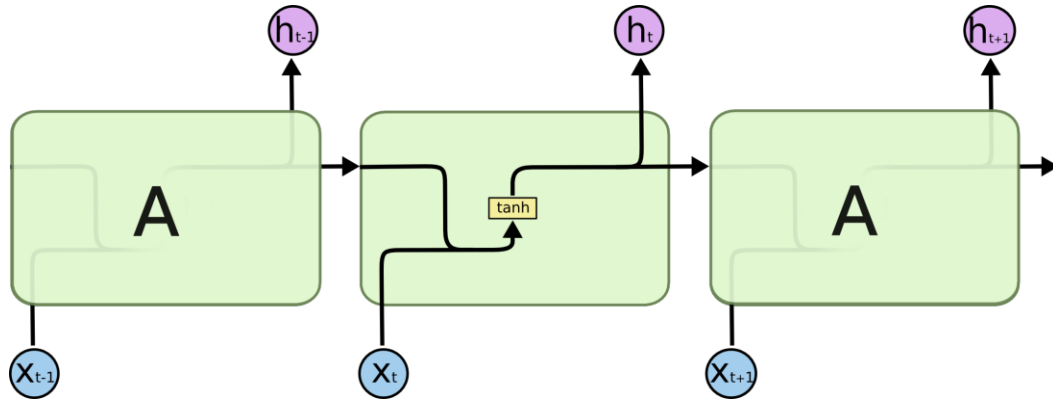

Figure 4 Simple structure of RNNs looping module. [11]

Whereas in LSTMs, instead of this simple structure, they have four network layers interacting in a special way. General architecture of LSTMs is shown in Figure 5. Normally LSTM's are augmented by gates called “forget” gates. By controlling these gates, errors can be backpropagated through any number of virtual layers. This mechanism enables the network to learn tasks that depend on events that occurred millions of time steps ago.

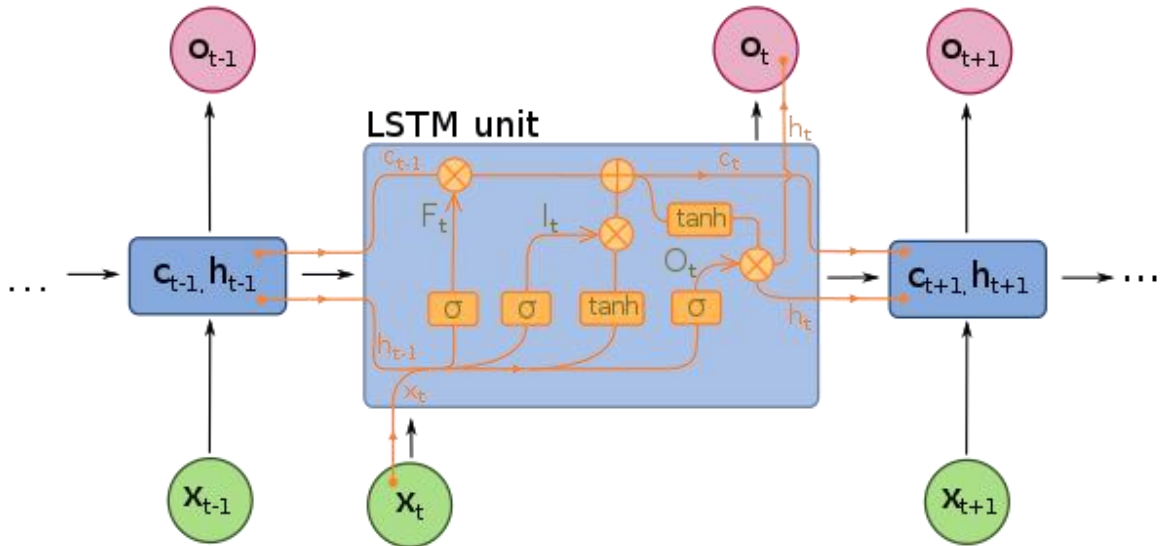

Figure 5 Long short-term memory unit [12]

## 2.2 Related Work

Mining time series data and the information from textual documents is currently an emerging topic in the data mining society. Increasingly many researchers are focusing their studies on this topic [13], [14], [15]. Currently, many of the approaches deal with a single time series. The relationships between different stocks and influences they can have on one another are often ignored. However, this is valuable information. For example, if the price of Honda's stocks goes down, that may trigger a movement of stock prices of Toyota.

Number of researchers published papers in the last decade on different strategies. Two interesting approaches dealing with mining the information from news and forecasting future stock price were considered. These approaches are briefly explained in the following sections.

### 2.2.1 Using stacked auto encoders (SAEs) and long short-term memory (LSTM)

Wei Bao, et al. [16] presented a novel deep learning framework where stacked auto encoders, long-short term and wavelet transforms (WT) are together used for stock price prediction. The SAEs for the deep features which are extracted hierarchically is introduced in forecasting the stock price in this paper for the first time. This deep learning framework consists of 3 stages. Firstly, WT decomposes the time series of the stock price to eliminate noise. Then, for generation of deep high-level features, SAEs are applied for stock price prediction. Lastly, high-level denoising features are fed into long short-term memory to predict closing price of the next day. Performance of the proposed model is examined by choosing 6 market indices and their corresponding features. In both predictive accuracy and profitability performance, this approach had claimed to outperform other similar models.

### **2.2.2 Integrating Text Mining Approach using Real-Time News:**

News is a very important factor which effects the stock prices. A positive article about a company's increased sales may directly correlate with the increase in its stock price, and vice-versa. A novel approach for mining text from real time news and thus predicting the stock prices was proposed in the paper by Pui Cheong Fung, et al [17] . Mining textual information from the documents and time series simultaneously is a topic of raising interest in data mining community. There is a consistent increase in the number of researches conducted in this area [18] [14]. In this paper, a new approach is proposed for multiple time series mining. It involves three procedures as follows: 1) discovery of potentially related stocks; 2) selection of stocks; and 3) alignment of articles from different time series.

### **2.2.3 Stock Price Prediction using Linear Regression based on Sentiment Analysis**

In 2015, Yahya, et al. [19] tried to utilize the sentiment of the posts from social media websites like twitter to predict the stock prices in Indonesian Stock Market. They used naïve Bayes, support vector machines and random forest algorithms to classify tweets about companies and compared the results of the different algorithms. They claimed that the random forest model had achieved best performance among the 3 algorithms with 60.39% accuracy. Naïve Bayes stood as the second-best model with 56.50% accuracy. Then they have used supervised classification algorithms such as SVM, Decision Trees and linear regression as predictive models and attempted to predict price fluctuation and margin percentage. A comparative analysis was performed on the results of all the models.

### **2.3 Limitations of existing models**

While most of the previous research in this field were concentrating on techniques to forecast stock price based on the historical numerical data such as past stock trends, there is not much research put into the textual analysis side of it. News and media has huge influence on human beings and the decisions we take. Also, fluctuations in the stock market are a result of the trading activities of human beings. As news articles influence our decisions and as our decisions influence the market, the news indirectly influence the stock market. Therefore, extracting information from news articles may yield better results in predicting the stock prices. News sensitive stock trend prediction [14], sentiment polarity analysis using a cohesion based approach [20], mining of text concurrent text and time series [15] are some of the distinguished works in the domain.

However, there are few issues in the above-mentioned works. First being many of these researches used Bag of Words (BoW) approach to extract information from the news reports, despite of the fact that the BoW approach cannot capture some important linguistic characteristics such as word ordering, synonyms and variant identification. Next, most works either used just the numerical information or textual information, whereas the market analysts used both. Also, previous approaches did not consider the fact that the stock prices between the companies is correlational. Finally, the approaches which used textual information to forecast, did not consider stock prices as time series.

## Chapter 3

### Proposed Approach

In this research we perform both numerical analysis and the textual analysis on the stocks and news dataset to try predicting the future price of the stock. Numerical analysis will be performed by treating the stock trend as a time series and we try to forecast future prices by observing the prices over last  $x$  number of days. In textual analysis we perform sentiment analysis of the news articles and learn the influences of news on stock prices. Finally, predictions from these two models will be used as input to a merged model to output final predictions.

### 3.1 Numerical Analysis

Numerical analysis aims at building a recurrent neural network based model to predict the stock prices of S&P500 index. RNNs are good at learning and predicting time series data. As stock market data is a time series, RNNs are best suitable for this task. For this purpose, we use a specific type of RNNs called as Long Short-Term Memory. As explained in Chapter 2 – Background section, LSTM is specially designed cell which can help the network to memorize long term dependencies. In numerical analysis, we try to learn the patterns and trends of stock prices over the past, and this information will be augmented by the textual information later.

S&P 500 index data from 3<sup>rd</sup> January 1950 until 31<sup>st</sup> December 2017 downloaded from Yahoo! Finance GSPC is used for this purpose. To simplify the problem, we use only the closing prices of the stock index. Stock prices are a time series data of length  $N$ . We choose a sliding window  $w$  of variable size, which moves step by step from the beginning of the time series. Figure 6 illustrates the sliding window  $w_t$  which is used as the input to predict  $w_{t+1}$ .

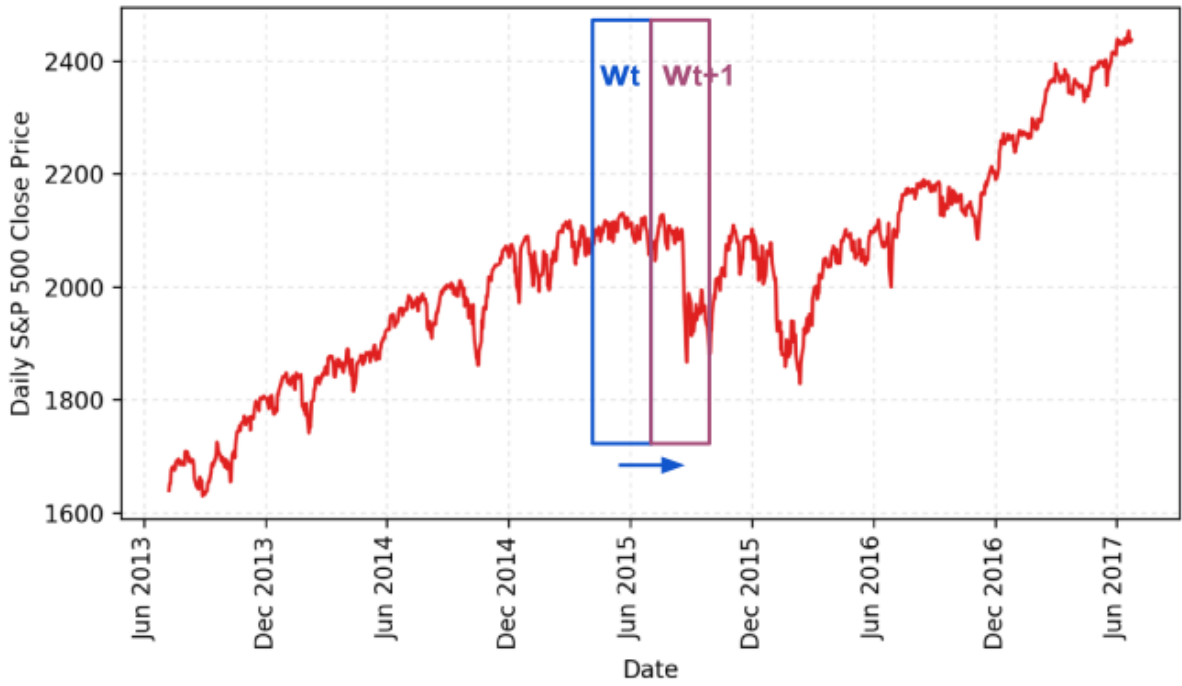

Figure 6 Sliding window learning the trends in stock price [21]

While moving the sliding window, we move it to the right by the window size so that there is no overlap between the previous window and the current window. Each input window at each step is passed to a LSTM cell which acts as the hidden layer. This layer would predict values of the next window. While predicting the prices for window  $W_{t+1}$ , we use values from the first sliding window  $W_0$  until the current time  $W_t$ , where  $t$  is the time.

$$W_0 = (p_0, p_1, \dots, p_{w-1})$$

$$W_1 = (p_w, p_{w+1}, \dots, p_{2w-1})$$

$$W_t = (p_{tw}, p_{tw+1}, \dots, p_{(t+1)w-1})$$

The function we are trying to predict is:

$$f(W_0, W_1, \dots, W_t) \approx W_{t+1}$$



The output window  $W_{t+1}$ :

$$W_{t+1} = (p_{(t+1)w}, p_{(t+1)w+1}, \dots, p_{(t+2)w-1})$$

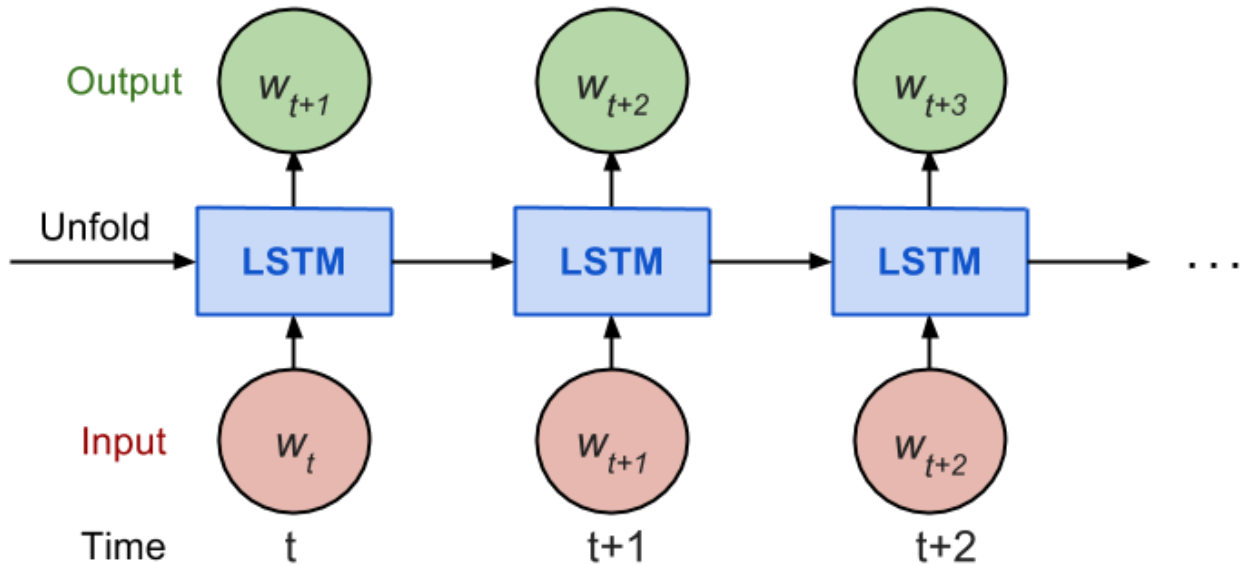

Figure 7 Unrolled version of the network for Numerical Analysis

During the training process, predicted output is calculated by using the randomly assigned weights and compared with the actual value. Error is calculated at the output layer and it is propagated back through the network. This is called back propagation and as this is applied to a timeseries like data as in our case, we call it Back Propagation Through Time (BPTT). During backpropagation, we update weights to minimize the loss in the next step. To update the weights, we calculate the gradient of the weight by multiplying weight's delta and input activations then subtract a ratio of this gradient from the weight. This ratio would influence the quality and speed of the training. This ratio is called Learning Rate. If the learning rate is set high, the network learns fast but the learning will be more accurate when the learning rate is low. Learning process is repeated until the accuracy or loss meets a threshold.

By the design of RNNs, they depend on arbitrarily distant inputs. Due to this, backpropagation to the layers very far away requires heavy computational power and memory. In order to make the learning feasible, the network is unrolled first so that it contains only a fixed number of layers. The unrolled version of the recurrent neural network is illustrated by Figure 7 Unrolled version of the network for Numerical Analysis. The model is then trained on that finite approximation of the network.

During training, we feed inputs of length  $n$  at each step and then perform a backward pass. This is done by splitting the sequence of stock prices into non-overlapping small windows. Each window will contain “ $s$ ” numbers. Each number is one input element and “ $n$ ” consecutive such elements are grouped to form a training input.

For example, if  $s=2$  and  $n=3$ , the training example will be as follows.

Input1 = [[ $p_0, p_1$ ], [ $p_2, p_3$ ], [ $p_4, p_5$ ]], Label1 = [ $p_6, p_7$ ]

Input2 = [[ $p_2, p_3$ ], [ $p_4, p_5$ ], [ $p_6, p_7$ ]], Label2 = [ $p_8, p_9$ ]

Input3 = [[ $p_4, p_5$ ], [ $p_6, p_7$ ], [ $p_8, p_9$ ]], Label3 = [ $p_{10}, p_{11}$ ]

Where  $p$  is the stock price at a single instance of time.

#### Dropout parameter:

Deep neural networks with many parameters are powerful systems to learn most of the complex tasks. However, they suffer from the problem of overfitting. The problem is that generally the available data will be limited and in most cases, it will not be sufficient enough to learn complex patterns in the data. As the underlying patterns between inputs and the output can only be mapped using a non-linear approximation function, the hidden layers tend to fit a higher order function to accurately map the outputs. By doing so, they perform best during training but fail miserably during testing. Therefore, we use regularization techniques to avoid overfitting. In

general machine learning algorithms, regularization is achieved by using a penalty to the loss function or combining the results from different models and then averaging it. But neural networks are more complex and as they require comparatively higher computational resources, model averaging is not a solution. Therefore, we use a technique called dropout, in which we randomly drop a few units from the network during training, thus preventing co-adaptation between the units.

We use the dropout technique in our model to avoid overfitting. The model will have a configurable number of LSTM layers ( $n$ ) stacked on top of each other and in each layer, there are a configurable number of LSTM cells ( $l$ ). Then there is a dropout mask with a configurable percentage ( $d$ ) of number of cells to be dropped during the dropout operation. We calculate the keep probability ( $k$ ) from  $d$ , which is basically derived from the below equation

$$k = 1 - d$$

The training process takes place by cycling over the data multiple times. Each full pass over all the data points is called an epoch. In total, training requires  $m$  number of epochs over the data. In each epoch, the data is split into  $b$  sized groups called mini-batches. In one Back Propagation Through Time learning, we pass one mini batch of data as input to the model for training. After each step, we update the weights at a rate defined by the configurable parameter “ $\eta$ ”, which represents learning rate. As explained earlier, higher learning rate lets the network to train faster, but to achieve better accuracy, we need a lower learning rate. In order to find an optimal value, initially we set learning rate to a higher value and at each succeeding epoch it decays by multiplying it with a value defined by “ $\delta$ ” (stands for learning rate decay).

**Implementation:**

We used tensorflow library to model the network. We first define the placeholders for inputs and targets as follows.

```
inputs = tf.placeholder(tf.float32, [None, n, s])
targets = tf.placeholder(tf.float32, [None, s])
learning_rate = tf.placeholder(tf.float32, None)
```

We create the LSTM cell and wrap it with a dropout wrapper to avoid overfitting of the network to the training dataset.

```
def _create_one_cell():
    lstm_cell = tf.contrib.rnn.LSTMCell(l, state_is_tuple=True)
    lstm_cell = tf.contrib.rnn.DropoutWrapper(lstm_cell, output_keep_prob=k)
    return lstm_cell
```

Number of layers of LSTM cells in the network are configurable. This will be passed as an input to the program. When multiple LSTM cells are used, we try to stack them using the tensorflow's MultiRNNCell class. This class helps in connecting multiple LSTM cells sequentially into one composite cell.

```
cell = tf.contrib.rnn.MultiRNNCell( [_create_one_cell() for _ in range(l)],
                                     state_is_tuple=True)
```

The Dynamic RNN class present in the TensorFlow library will create the RNN specified by the RNNCell created in previous step.

```
val, _ = tf.nn.dynamic_rnn(cell, inputs, dtype=tf.float32)
```

The last column of the result of above dynamic RNN is then multiplied with weight and bias is added to get the prediction of this step.

prediction = tf.matmul(last, weight) + bias

Loss is calculated by squaring the difference between the predicted value and the true value, then finding the mean of the result.

$$\text{MSE} = \frac{1}{n} \sum_{i=1}^n (Y_i - \hat{Y}_i)^2.$$

Where  $Y_i$  is the vector representing actual values of the stocks and  $\hat{Y}_i$  is the vector representing predicted stock values. We use RMSProp optimization algorithm to perform gradient descent. Learning rate is passed as a parameter to the RMSPropOptimizer and this learning rate will be gradually decayed by the decay parameter in each epoch. After training for the specified number of epoch, the training stops.

### **Normalization:**

At each step, latest 10% of the data is used for testing and as the S&P 500 index gradually increases over time, test set would have most of the values larger than the values of training set. Therefore, values which are never seen before are to be predicted by the model. Following figure shows such predictions.

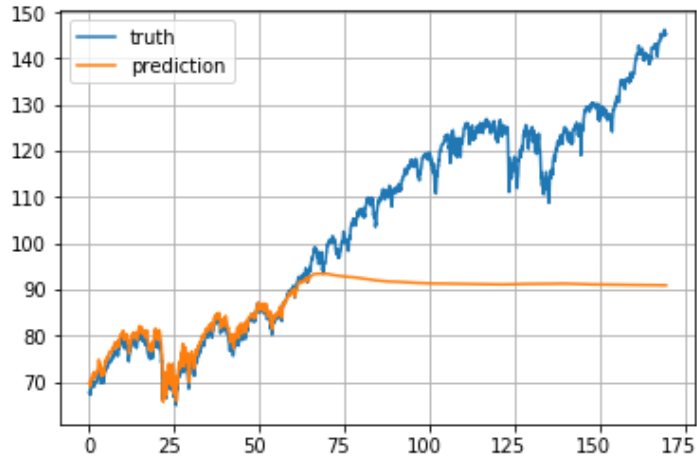

We can see from the above figure that the predictions are worse for new data. Therefore, we normalize the values by the last value in the previous window, thus we will be predicting relative changes in the prices instead of the absolute values. Following is the equation for normalizing the values in a window.  $W'_t$  is the normalized window and  $t$  is the time.

$$W'_t = \left( \frac{p_{tw}}{p_{tw-1}}, \frac{p_{tw+1}}{p_{tw-1}}, \dots, \frac{p_{(t+1)w-1}}{p_{tw-1}} \right)$$

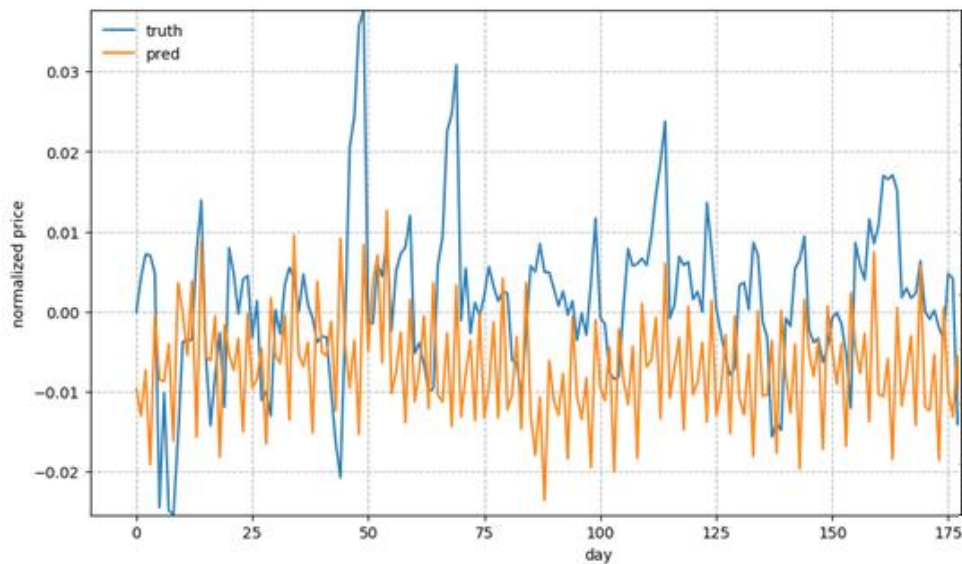

Above figure shows that after normalization, model is able to predict better for new data.

### 3.2 Textual Analysis

In textual analysis, we analyze the influence of news articles on stock prices. For this purpose, news articles from websites like reddit were downloaded, and sentiment of the headlines was calculated. Then we tried to correlate them with the stock trend to find their influence on the market. Even though sentiment can reveal whether the news is positive or negative, it is hard to know how much it would affect the stock price. Therefore, the problem of predicting the exact stock price was simplified to problem of predicting whether the stock price rises or falls, by transforming the values of close price column to Boolean having values 0 or 1. A value of “1” denotes that the price increased or stayed the same, whereas “0” indicates that the price reduced.

Following are some of the examples of news headlines which influenced the stock prices.

Date	Headline	Influence
2014-03-19	A Surprising Number of Places Have Banned Google Glass In San Francisco	Negative
2014-03-20	Lawsuit Alleges That Google Has Crossed A 'Creepy Line'	Negative
2014-05-02	Google to Acquire Favorite Live Streaming Service Twitch for \$1B	Positive
2014-05-21	Google overtakes Apple as Most Valuable Global Brand	Positive
2014-05-22	Google Inc (GOOGL) Plans to Spend \$30 Billion On Foreign Acquisitions	Positive
2014-06-19	Heads up: Hangouts is being weird today (other Google services too)	Negative
2014-07-09	Google Co-Founders Talk Artificial Intelligence Just a Matter of Time	Positive

*Table 1 Sample news headlines and their influence on stock price*

Then this vector was passed to machine learning algorithms to find mapping between sentiment values and output trends.

We have the following research problems at this stage.

1. What machine learning algorithms perform best in learning the correlation between news and stock trend?
2. Does the news about other companies in the same field have influence on the stock prices of a company?
3. How many days would it take for the published news to influence the market?

For research problem 1, we chose two approaches as discussed below.

### **Machine Learning Model – Approach 1 - SVM:**

In the first approach, we calculated sentiment of the news articles and used a machine learning model like Support Vector Machines to find the mapping between sentiment vector and stock trends. To calculate the sentiment, we have used Valence Aware Dictionary and Sentiment Reasoner (VADER) which is a lexicon and sentiment intensity analyzer specially tuned to sentiments expressed in social media. As the headline of a news article can provide enough context to analyze the sentiment, we ignore the body of the article and consider only the headline for analysis. For each headline, sentiment polarity and intensity is calculated using VADER algorithm, which returns a value from 0 to 1 to represent a positive polarity and the magnitude represents the intensity, and returns a value from 0 to -1 to represent negative polarity. 0 can be treated as neutral sentiment. A vector is created using these sentiment values and this vector is passed as the input to the SVM model for training, whereas the target is a boolean vector representing rise or fall of stock price.



## Machine Learning Model – Approach 2 - LSTM:

In this approach, recurrent neural networks were used to map the function between sentiment values and the target price. Specifically, we used Long Short-Term Memory network as they were proven to be successful with text data. As the target variable we are predicting is either 0 or 1, this would be a classification problem. Therefore, architecture of the neural network is designed in such a way that it outputs a fully connected layer with softmax or sigmoid activation function.

Architecture of the LSTM network is illustrated by the Figure 8 LSTM network architecture for textual analysis.

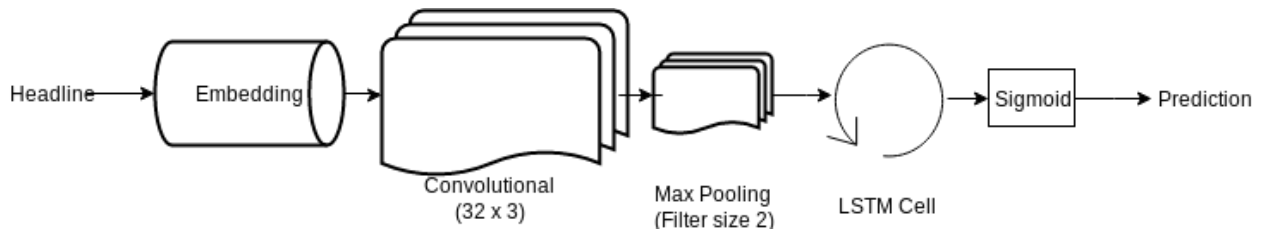

Figure 8 LSTM network architecture for textual analysis

### Network:

#### Input:

The news headlines are first preprocessed and passed as inputs to the neural network. During preprocessing, all non-alphabetical characters were removed and rest of the characters were decapitalized. Next word embeddings are calculated.

#### Word Embeddings:

In NLP, word embeddings is a technique of representing words as vectors of real numbers in which words with similar meanings will have similar representation. This is one of the key breakthroughs in deep learning that achieved impressive performance for NLP problems.

Words are represented in a distributed vector space based on their usage, and therefore words which are used similarly will have similar representation. First tokenizer takes the input words and indexes the text corpus based on word count, term frequency inverse document frequency (TF-IDF). For indexing we store a maximum of 2000 words in the corpus. Therefore, the words which are not present in top 2000 will have the index set to 0. The headlines are transformed into vectors of fixed size of 100. If the headline is shorter than 100 words, zeros are padded to it. Then, these vectors are passed to an Embedding Layer in the neural network.

#### Convolutional Layer:

A convolutional layer consists of a set of filters whose weights are learnt during the training process. Dimensions of the filter are spatially smaller than the input vector's dimensions but will have the same depth. During a forward pass, the filters are slid over the width and height of the input vector and dot product is calculated between the values of the filter and the input at each position. The convolution process is shown in Figure 9, where I is the input vector and K is the filter. During the training process, network will learn these filters that activate when they see the target concealed in the input.

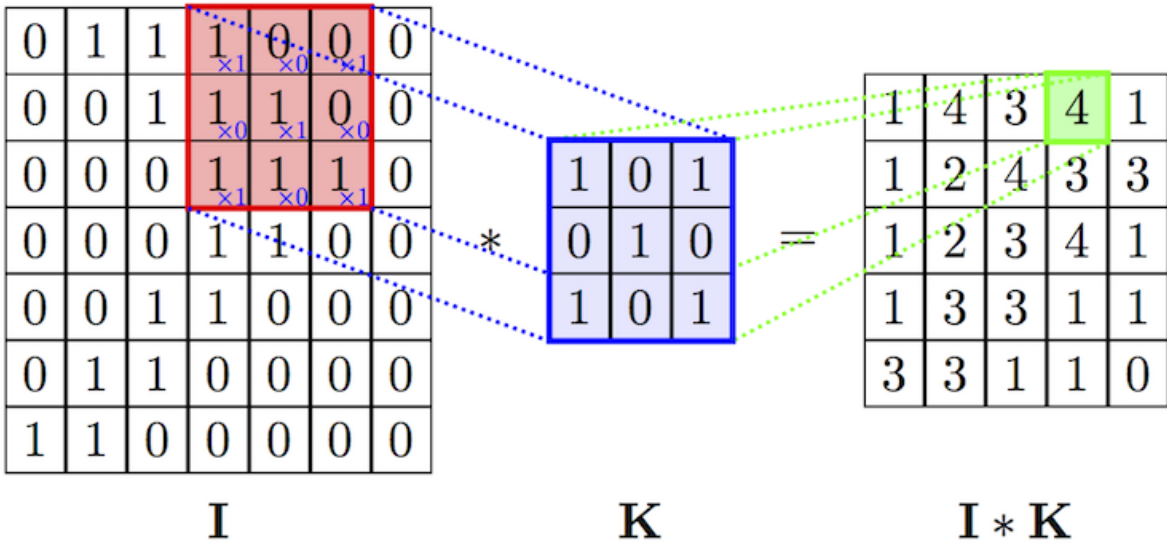

Figure 9 Convolution of input vector I using filter K [22]

As we know convolutional layers are generally used for images as they are suitable for matrix representations. But as embedding vectors are also matrix representations of words, convolutional layers can be applied to word embeddings [23]. As images are more meaningful as a 2-dimensional representation than one dimensional array like representation, 2D convolution layer is used for images and for videos a 3D convolution layer is used. But in case of sentences (or words), a single dimension makes more sense than 2D or 3D. Therefore a 1-dimensional convolution layer is used for processing textual information.

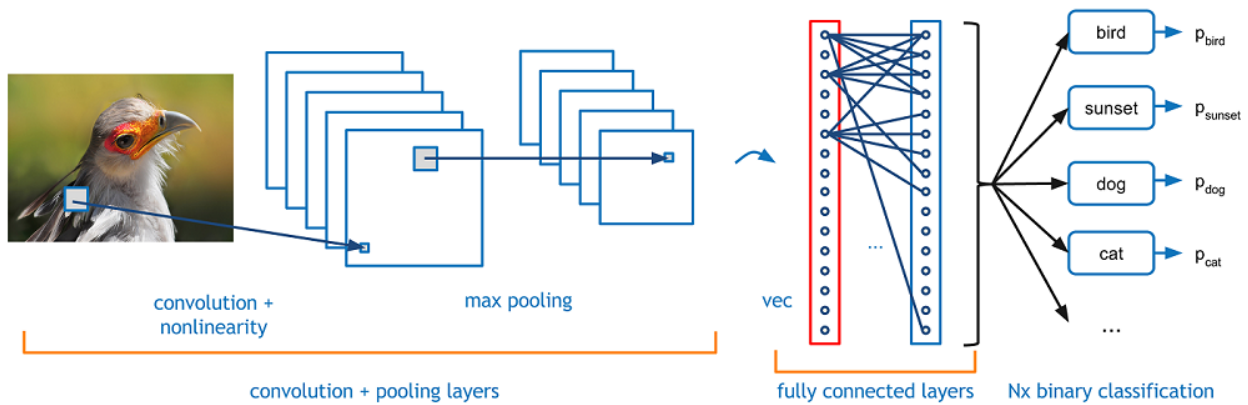

Figure 10 Convolutional Neural Network for Image Classification [24]

A typical convolutional neural network for image classification problem is shown in the Figure 10. In the above example the sliding window (called filter) scans over the image and transforms pixel information into a vector or matrix representation. Similarly, for sentences we use 1 dimensional layer as shown in Figure 11.

In convolutional layers, a window or typically called as a filter, will be sliding over the input vector, at each step calculating convolution of the filter over data. To reflect the word negations, filter should consider the surrounding words to the current word. Therefore, we chose a kernel size of 3, so that word negations are accounted in the weights.

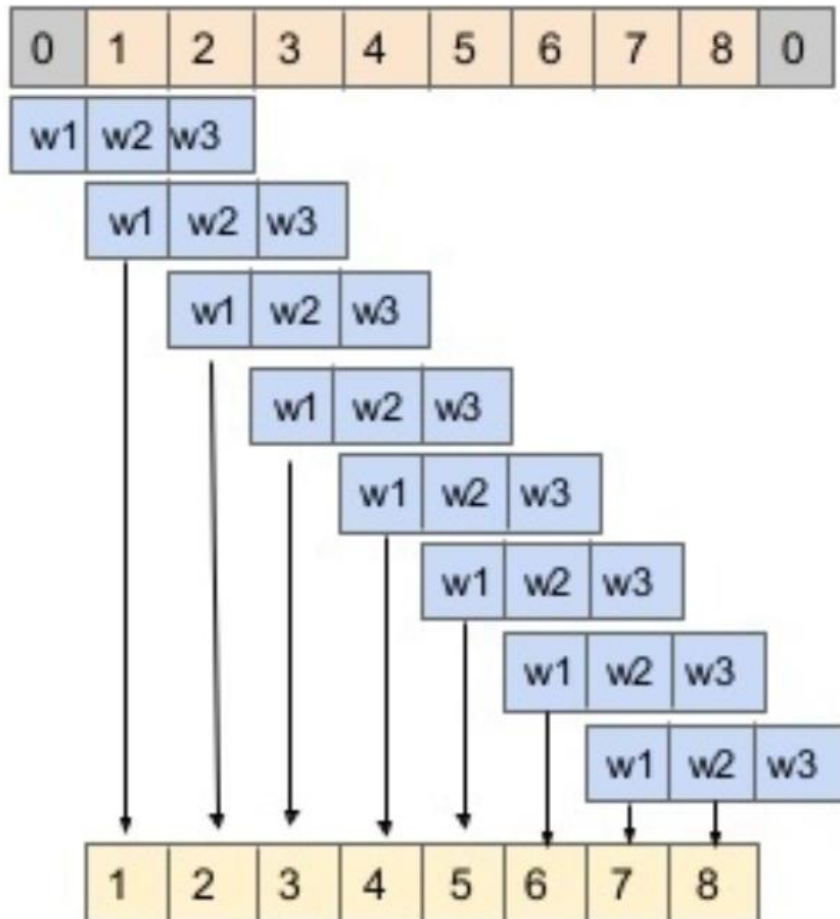

Figure 11 Convolution of single dimensional vector input [25]

### Max Pool Layers:

Generally, a pooling layer is inserted between successive convolution layers in a convolutional network architecture. Pooling layer progressively reduces the spatial size of the representation thereby significantly reducing the number of parameters, computation in the network and controlling overfitting. Pooling layer is simply a max operation applied on every slice of input with specified dimension. Since the neighboring values in the convolutions are strongly correlated, it is understandable to reduce the output size by subsampling the response from filter. It is most common [26] to use a max pool layer of size 2, as values further apart are less correlated.

### LSTM Cell:

Output from the max pool layer is passed as the input to the LSTM cell. LSTM cell will have 3 main parameters to be set. They are number of units, activation function and recurrent activation function. Number of units is found by cross validation. Recurrent activation is applied to inputs, forget gate and the output gates, whereas the activation is applied to candidate hidden state and the output hidden state. Default values for recurrent activation function is a hard-sigmoid function and for activation function default value is hyperbolic tangent function.

### Output Layer:

As the network output is between 0 and 1, we use a sigmoid activation function in the output layer.

### 3.4 Merged Model

#### Step 1:

Numerical analysis model is capable of analyzing the stock trends from the given input window, extract patterns out of it and is able to predict the future trend. Whereas the textual analysis model is trained to get sentiments from the news articles and predict if the stocks would rise or fall. Therefore, the idea is that merging these two models should give better prediction results.

To achieve this, we train the numerical analysis model with past couple of months of stock trends related to a particular company. This model will output the predicted prices  $\mathbf{P}$  for next  $\mathbf{p}$  number of days. Value of  $\mathbf{p}$  is calculated as follows.

$$\mathbf{p} = \text{size}(\text{Input Samples}) / (\mathbf{n} * \mathbf{s})$$

where,

$\mathbf{n}$  = number of steps in back propagation

$\mathbf{s}$  = number of elements in input window

Also, let the actual prices be  $\mathbf{Y}$ , which will be used later in Step 3.

#### Step 2:

Next, we train the textual analysis model with historical news related to that particular company and corresponding stock trends. This model will learn what type of news can trigger a rise in stock price and what type of news can trigger a fall in stock price. In step 2, news headlines for each day in  $\mathbf{P}$  are collected and passed as input to textual analysis model. This will output the vector with probabilities of rise or fall for each day. Let's call this vector  $\mathbf{N}$ .

Step 3:

Now we have the predicted prices vector  $\mathbf{P}$ , news predictions vector  $\mathbf{N}$  and the actual prices vector  $\mathbf{Y}$ . We will now pass the vectors  $\mathbf{P}$  and  $\mathbf{N}$  to an SVM regressor as inputs and  $\mathbf{Y}$  as the output. After training SVM will learn how values of  $\mathbf{N}$  will influence  $\mathbf{P}$ . Output of this merged model are the final predictions using both numerical analysis and textual analysis.

## Chapter 4

In this chapter we are going to discuss our experiments and results of the models mentioned until now. We will first go through the metrics we used to evaluate the models and then we will summarize the experiments on the numerical analysis model, textual analysis and the merged model.

### 4.1 Metrics

#### Mean Squared Error:

Mean Squared Error (MSE) of an estimator measures the average of squares of the errors. The term error here denotes the difference between the actual value and the estimated value. Below equation denotes the mathematical equation for calculating the mean squared error.

$$\text{MSE} = \frac{1}{n} \sum_{i=1}^n (Y_i - \hat{Y}_i)^2.$$

Here  $Y_i$  represents the vector of the actual values and  $\hat{Y}_i$  is the vector of predicted values.

MSE is generally used when we have vectors with continuous values. We will be using this metric for comparing the results of the Numerical Analysis models and the merged model.

#### Accuracy:

Accuracy of a binary classifier is a statistical measure of how well the classifier is able to predict the correct values. It is the percentage of true results among total number of samples. It is denoted by the below equation.

$$\text{Accuracy} = \text{True Positives} / \text{Total number of predictions}$$



Accuracy is a metric generally used for classification problems. As in textual analysis, we converted the problem of predicting exact stock prices to predicting whether the price increased or decreased, we can use the accuracy as the metric to evaluate the model.

#### **4.1 Experiments on Base Model**

We have used SVM regressor implementation from Scikit Learn machine learning library as the base model for evaluation. Stock prices are split into windows of fixed sizes. At each step prices in one window are passed as the input to train the model and the next day's stock price is passed as the target variable. Therefore, the input vector  $X$  will be a 2-dimensional array of  $n$  input samples where each input sample will contain a sequence of stock prices in one window. The output vector  $y$  is a 1-dimensional vector of stock prices where each element in the vector is the stock price on the day next to corresponding input window. Based on cross validation, we have chosen Radial Basis Function (RBF) as the kernel to the SVM and input window size of 15. Following are the predictions with input window size 10 and 15.

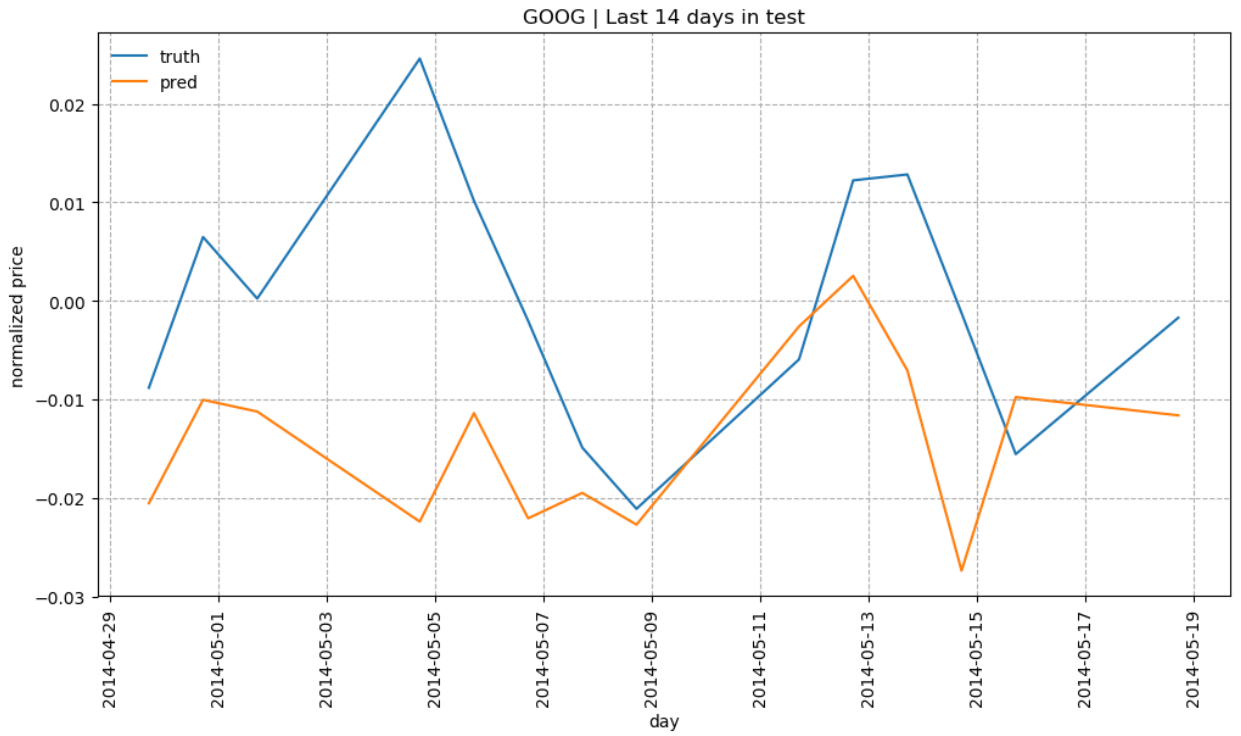

Figure 12 SVM with RBF kernel with Window Size 10

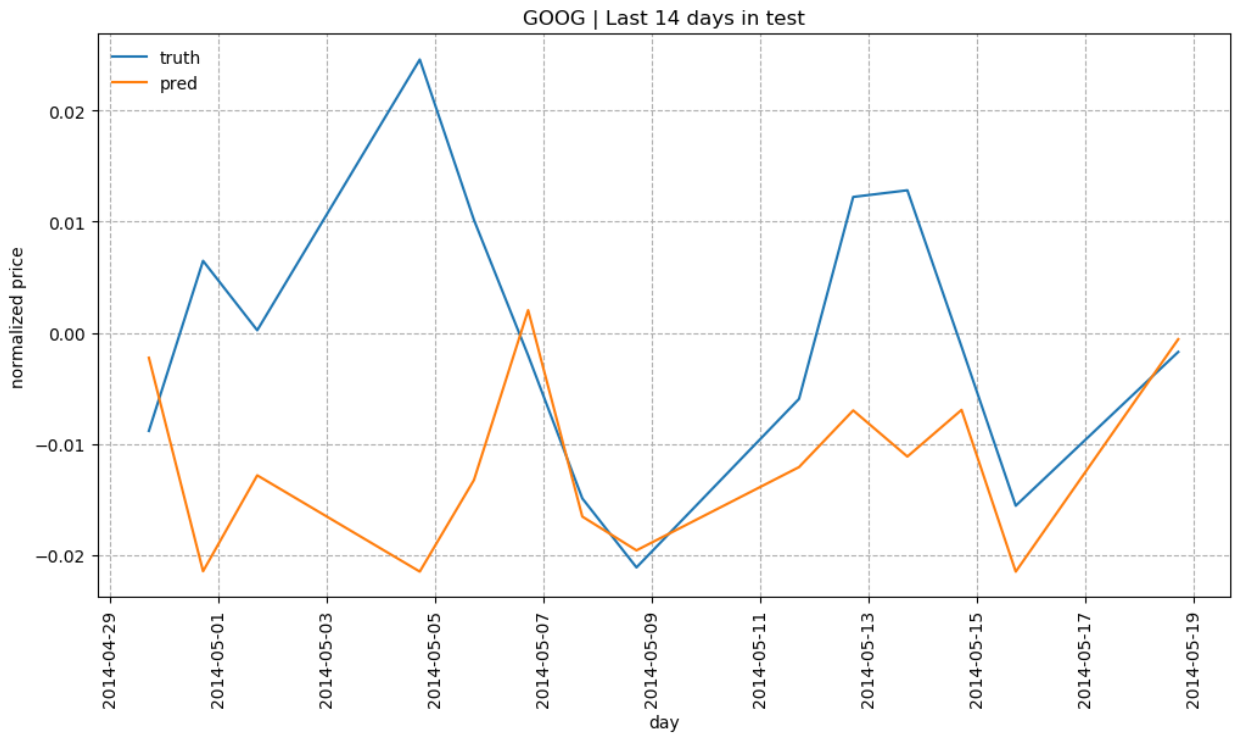

Figure 13 SVM with RBF kernel with Window Size 15

Corresponding mean squared error for Window size 10 is 0.000757094 and for Window size 15, the error is 0.0007262213, therefore the model with window size 15 and RBF kernel is chosen as base model.

## 4.2 Experiments on Numerical analysis

In the experiment, we compare the predictions of the LSTM model we designed as part of numerical analysis. Stock prices data was downloaded from Yahoo Finance for the companies Microsoft, Apple, Google and IBM. The data contains closing price of the above-mentioned companies for dates ranging from Sept 1<sup>st</sup>, 2004 till Dec 31<sup>st</sup>, 2017. As explained during the numerical model construction, the dataset will be split into groups where each group will have *input\_size* number of points. This can be imagined as a sliding window which starts at the beginning of the dataset and moves forward one group at a time. The model is trained by taking the current window as the input and tries to predict the values of next window. Therefore, the prices of the last window can be treated as the test values.

### Train / test split:

The data is split in such a way that 90% of the data is always used for training and the latest 10% is used for testing.

First, the model was trained with input size = 1 and lstm size = 32 to begin with. The results are as shown in the figure below. Mean squared error of this configuration is 0.0006770748.

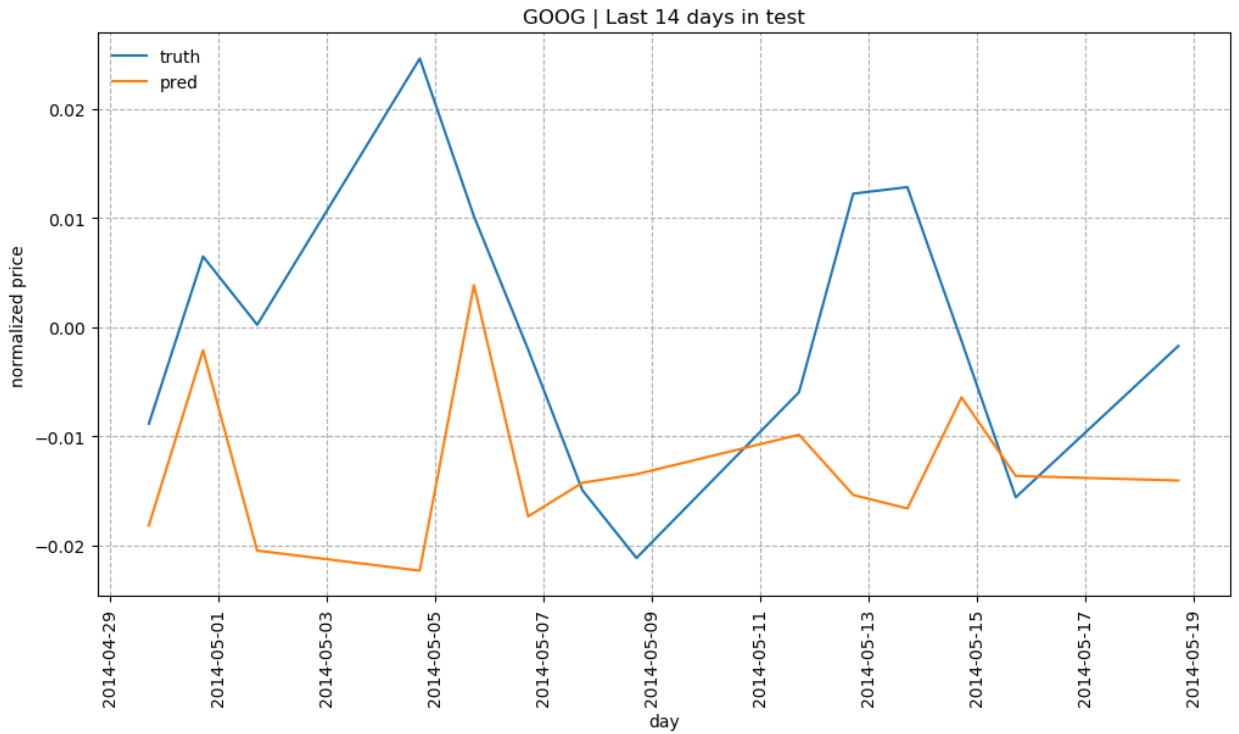

Figure 14 GOOG LSTM 32 InputSize 1

From the results we can observe that the predictions were not accurate enough to make the buying decisions.

As lstm size will denote the capacity of the LSTM cell, and depending on the amount of data, we have to choose an appropriate size. Therefore, we tried to tune the lstm size parameter. When the model was trained with lstm size = 128 and input size = 1, loss (MSE) is reduced. This can be observed from the below graph. Mean squared error of this configuration is 0.0006423764.

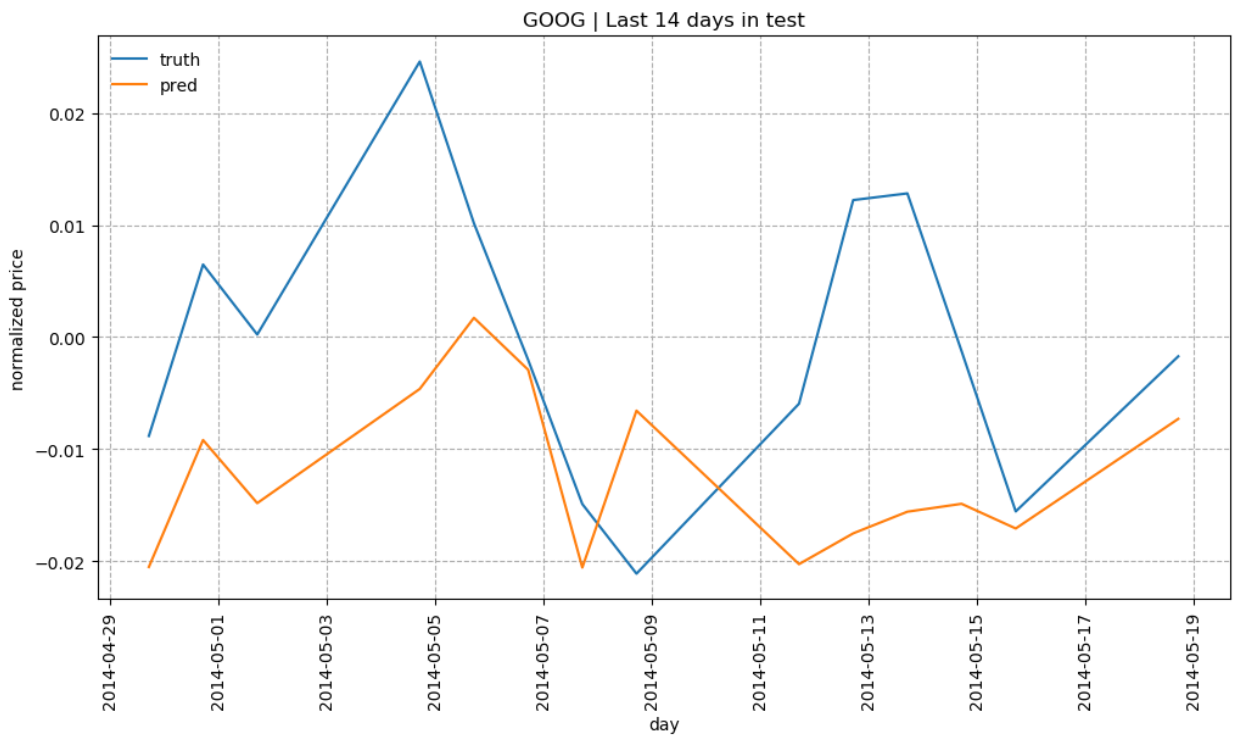

Figure 15 GOOG lstm size = 128 and input size = 1

Input size is another parameter to be tuned. Number of examples in the training window can be controlled by tuning the input size parameter. The model was trained with input size = 5 and lstm size = 128 and max\_epoch=75. The results are as shown in the figure below. Mean squared error of this configuration is 0.000453821.

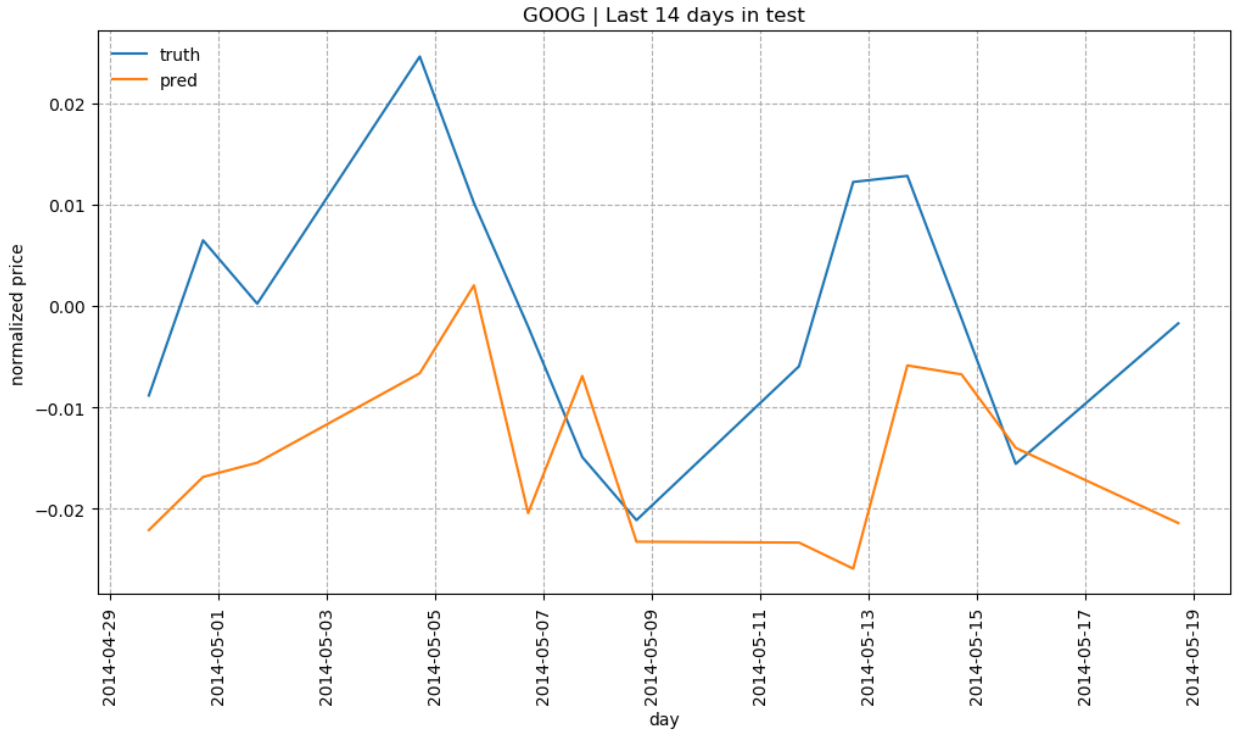

Figure 16  $input\_size=5$ ,  $lstm\_size=128$  and  $max\_epoch=75$

Mean Squared Error was reduced from 0.0006770748 to 0.000453821 after tuning the parameters.

### 4.3 Experiments on Textual Analysis:

#### 4.3.1 Experiment - Sentiment Analysis with SVM:

The dataset is downloaded from Kaggle [26]. It contains the date wise combined data from news articles from reddit and Dow Jones Industrial Average (DJIA). Top 25 News headlines were crawled from the reddit channel World News from the dates 06-08-2008 to 08-01-2014, on basis of highest number of user votes. DJIA data is downloaded from Yahoo Finance webpage from the date range 08-08-2008 to 08-01-2014. These two datasets are merged to form a single dataset in

which first column is the Date, second column is the Label. Label value 1 denotes that the prices rose or stayed the same and 0 denotes that the prices decreased. Columns from 3 to 27 represent the top 25 news headlines.

Rows are decomposed into multiple rows so that each row will have one news headline and the target column representing stock price rose or decreased. After cleaning the data, sentiment was calculated for each news headline using NLTK's Sentiment Analyzer. The sentiment analyzer decapitalizes letters and returns a positive score representing how positive a word is and vice versa for negative. The dataset is split into 7:3 ratio as training set and test set respectively. An SVM with a linear kernel is used to train from the training dataset using Cross Validation. Accuracy is chosen as the evaluation metric and the model resulted in 54.19% accuracy.

```

Connected to pydev debugger (build 172.3968.37)
[nltk_data] Downloading package vader_lexicon to
[nltk_data] C:\Users\abhin\AppData\Roaming\nltk_data...
[nltk_data] Package vader_lexicon is already up-to-date!
C:\Users\abhin\Anaconda3\lib\site-packages\nltk\twitter\ init .py:20: U
  warnings.warn("The twython library has not been installed. ")
Loaded decomposed data directly from file
No. of training samples: 40275
No. of testing samples: 9450
(40275,)
Training done.
Scores: [0.54189944 0.54189944 0.54189944 0.54189944 0.54189944]
Accuracy: 0.5418994413407822
Done.

Process finished with exit code 0

```

In the above approach, each row will have a news headline from a day and that day's closing stock price. As there can be both positive and negative news reported on the same day, it

may be ambiguous for the model to correlate the news with that day's stock price. Therefore, instead of placing each news headline in a row, scores of all the headlines belonging to a particular day are averaged to get the compound sentiment for each day. The compound news sentiment would serve as the input feature to the model and the day's closing stock price would serve as the target variable. After training, model achieved an accuracy of 54.22%. Averaging the sentiments did not have considerable impact as it resulted in just a 0.03% increase in the accuracy.

```

Connected to pydev debugger (build 172.3968.37)
C:\Users\abhin\Anaconda3\lib\site-packages\nltk\twitter\ init .py:20:
  warnings.warn("The twython library has not been installed. "
No. of training samples: 1610
No. of testing samples: 378
Training done.
Scores: [0.54179567 0.54179567 0.54347826 0.54205607 0.54205607]
Accuracy: 0.5422363483343251

Process finished with exit code 0

```

#### 4.3.2 Experiment – Prediction based on categorized news:

In the previous experiment, we have used news articles of all types and tried to predict the Dow Jones Industrial Average. As we can see from the results above, it did not result in a reliable accuracy. In this experiment, we tried to narrow it down to a specific field. We collected the categorized news data from UCI machine learning repository [27] which contained 422,937 news headlines of 5 months which are categorized into 4 groups, namely: entertainment, technology, business and health. For this experiment we have extracted technology news headlines from the UCI dataset and this data is combined with the stock data from companies Google, Microsoft,



Apple and IBM. Similar to the previous experiment the stock data is represented by a Boolean vector, where 1 denotes the stock price rose or stayed the same and 0 represents it decreased.

First, we tried to predict the Google's stock prices using the compound sentiment of all the technology news headlines published on a day. The dataset contains 108,344 such headlines. 70% of the dataset is used for training the SVM model. First technology news is aligned with same day's stock prices and the model is trained. Only 52.3% accuracy was achieved for same day's stocks. Then news is aligned with next day's stock values and that resulted in 59.98% accuracy. Finally, the news is aligned with stock prices 2 day after that which resulted in a reduced accuracy of 57.49%. From the results we observe that news is affecting the stock prices more, the day after it is published.

```

Training done.
[0.52334666, 0.52344255, 0.52344255, 0.52338462, 0.52338462]
Accuracy: 0.5234001975870853
Training done.
Backend Qt5Agg is interactive backend. Turning interactive mode on.
Predicting tomorrow's stock...
[0.59989232, 0.59989232, 0.59989232, 0.59989232, 0.59984615]
Accuracy: 0.599883090175476
Training done.
Predicting the day after tomorrow's stock...
[0.57497308, 0.57497308, 0.57497308, 0.57497308, 0.57492308]
Traceback (most recent call last):
Accuracy: 0.5749630802361767

```

The experiment was repeated by considering the news headlines related to only a specific company, by filtering out the text that doesn't contain that company's name. As expected, this resulted in a clear increase in accuracy.

```

Training done.
Predicting today's stock...
[0.66299862 0.66391185 0.66391185 0.66391185 0.66344828]
Accuracy: 0.6636364875072667
Training done.
Predicting tomorrow's stock...
[0.73452545 0.73415978 0.73415978 0.73415978 0.73517241]
Accuracy: 0.7344354399357439
Training done.
Predicting the day after tomorrow's stock...
[0.70839065 0.70936639 0.70936639 0.70936639 0.70896552]
Accuracy: 0.7090910674575065
Done.

Process finished with exit code 0

```

	Same day	1 day later	2 days later
Tech news	52.34%	59.98%	57.49%
Company news	66.36%	73.44%	70.91%

*Table 2 SVM model results for prediction using Tech news and Company only news*

### Experiment 4.3.3: Using LSTM Network to predict the Stock Prices

In section 3.2 we designed a LSTM model to predict stock trends from news sentiment. In this experiment we use this model for prediction and evaluate its performance. Experiments were conducted by using 2 different sets of news. First set contained all the news from technology category and the second contained only the company specific news.

For each of set of news, the model is trained with the price of same day, price a day later and the price two days later. Therefore, the result contained total 6 predictions for each company.

Company	Tech news			Company news		
	Same day	1 day later	2 days later	Same day	1 day later	2 days later
Apple	56.11%	60.86%	53.10%	81.55%	76.81%	75.85%
Google	58.83%	56.40%	54.47%	79.24%	84.53%	77.25%
IBM	60.20%	55.93%	57.89%	77.52%	83.33%	75.24%

*Table 3 LSTM model results for prediction using Tech news and Company only news*

Results produced by the LSTM model are much better than the predictions of the SVM model in Section 4.3.2. We can clearly notice that with company specific news we can predict the stock prices more accurately. Also, we can observe from the above results that the model is able to predict the prices consistently a day after the news is published and accuracy decreased for predictions 2 days after the news is published.

Now we have the trained textual analysis models which can derive prediction trends from news articles. The model with relatively better accuracy is chosen to be merged with the numerical analysis results. As the model “Company-news-1Day” is performing more accurately and consistently relative to the other models, we choose this model’s results to be merged with numerical analysis results.

#### **4.4 Experiments on Merged Model**

Configuration for Numerical model is chosen from section 4.2 based on the MSE metric. From section 4.3, models trained with company specific news affecting prices of same day and 1 day ahead are chosen to train the merged model. Google stock prices were divided into 2 parts in ratio of 70:30. First 70% of the dataset is passed to the numerical analysis model and results of it

are stored into a CSV file. Then these predictions along with rise/fall results for Google related news are passed to a SVM model.

The input vector would have the predictions from numerical model and corresponding boolean values (0 for fall, 1 for raise) from the textual model. Experiments are conducted by aligning the results of textual model with stock prices of same day and 1 day ahead. SVM model is trained by passing the normalized actual stock prices as the target vector. Predictions from the SVM model are shown in the Figure 17 News probabilities aligned and Figure 18 below.

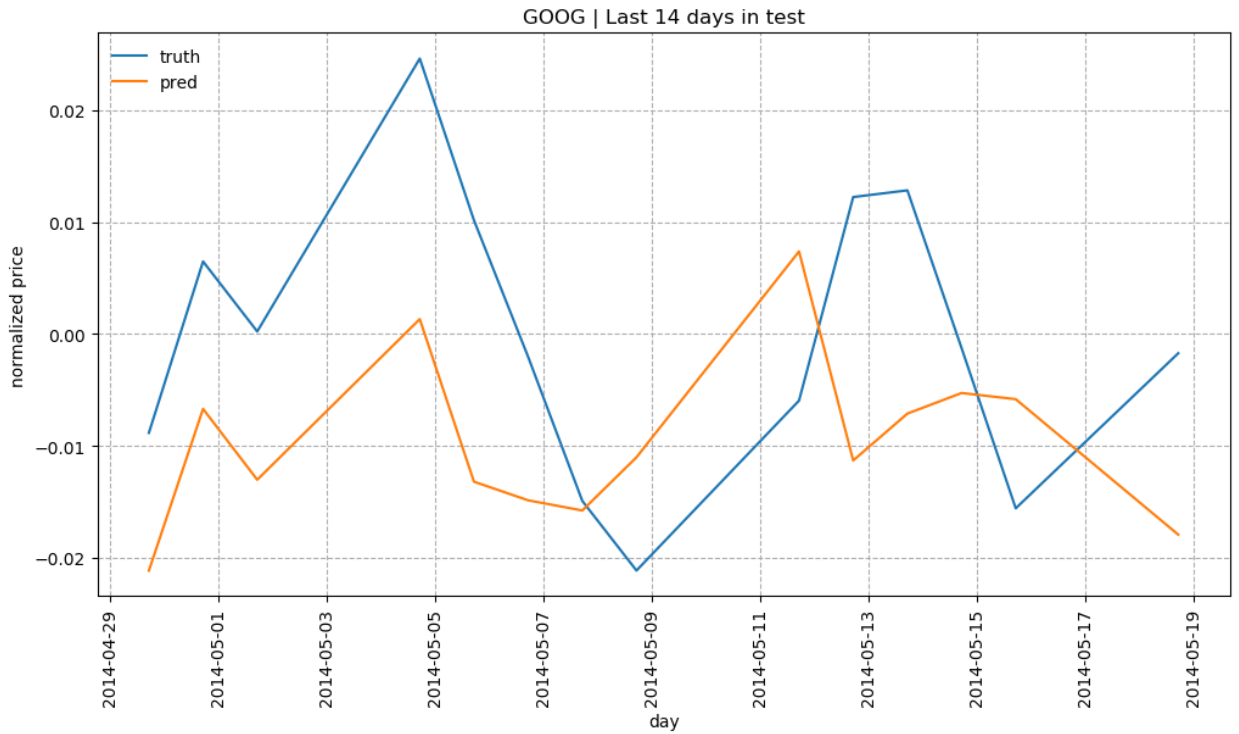

Figure 17 News probabilities aligned with same day's prices

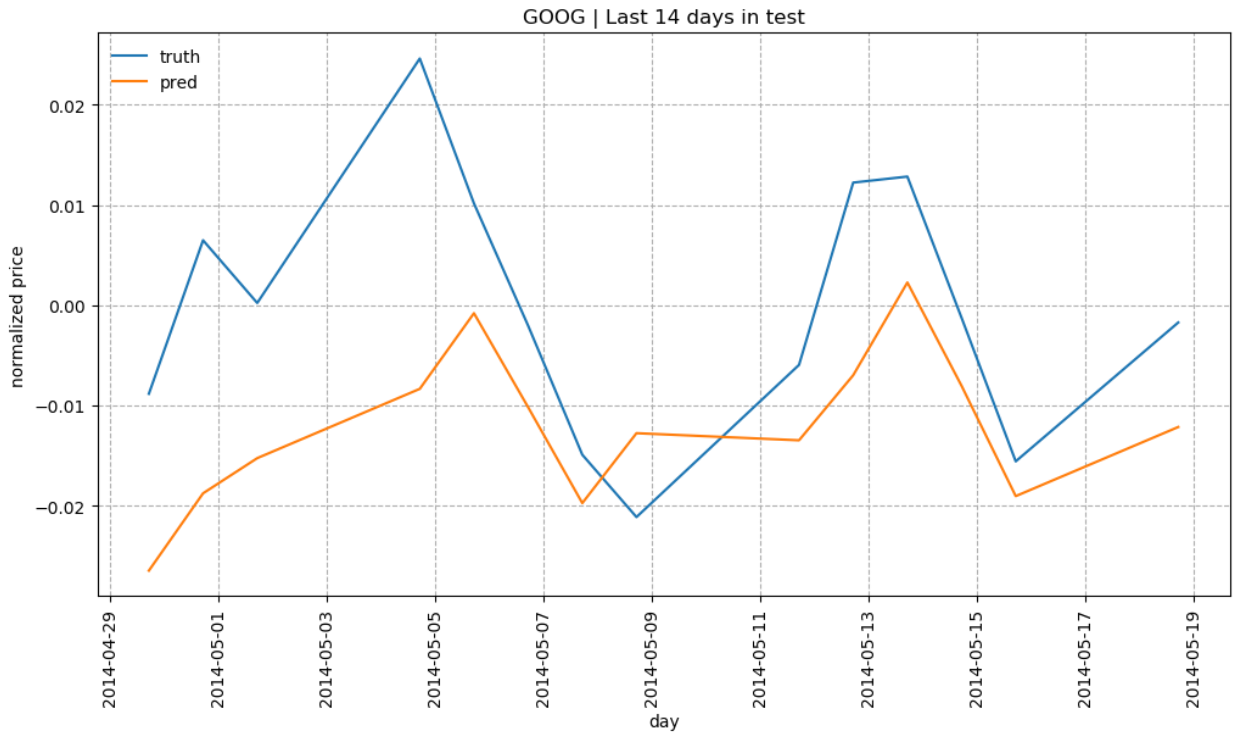

Figure 18 News probabilities aligned with prices 1 day ahead

Mean Squared Error for the predictions with rise/fall probabilities aligned with same day's prices is 0.0004138134 and prices 1 day ahead is 0.00037560132. We can see a good improvement in the predictions after augmenting with news data.

The following graph shows comparison between the prediction without news (only numerical analysis) and with news (numerical and textual analysis). It can be observed from the Figure 19 that prediction by augmenting information from news is more accurate than without it.

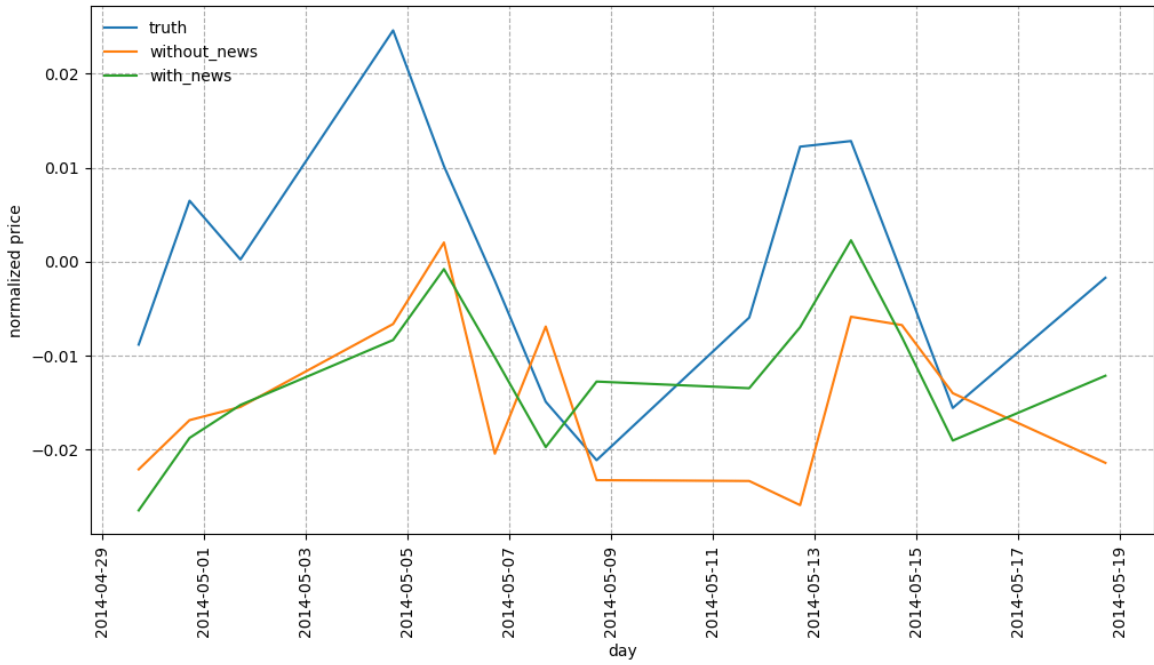

Figure 19 Comparison of predictions without news and with news

The following figure shows the comparison between the prediction using baseline model and the prediction using the proposed approach.

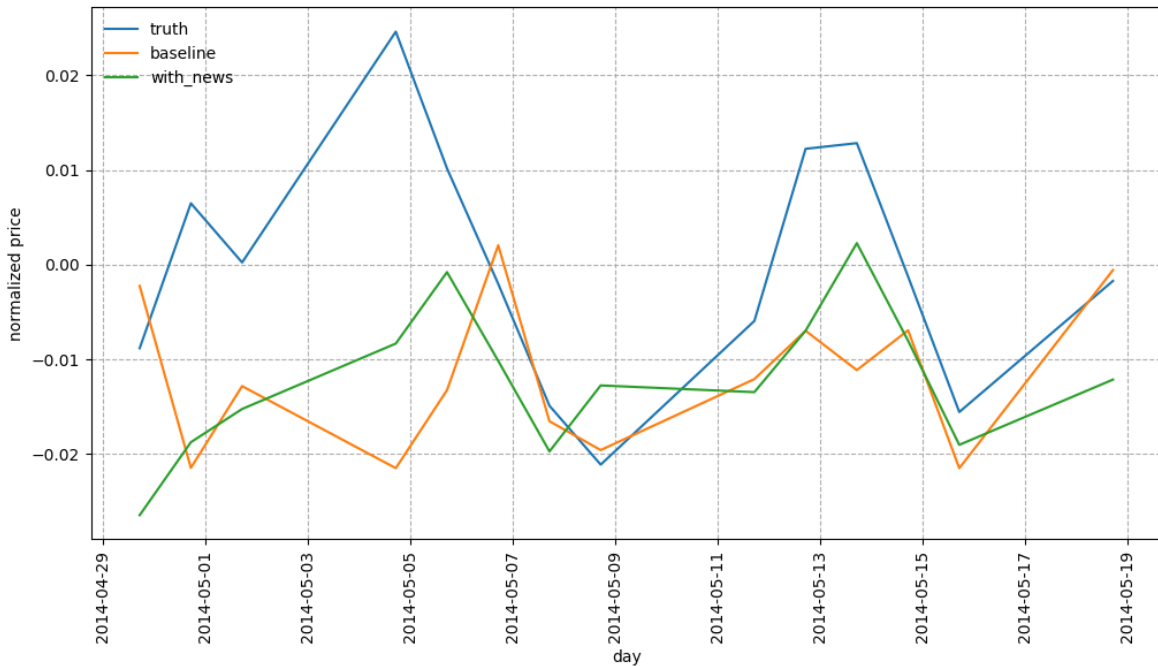

Figure 20 Comparison of predictions with baseline model and proposed model

## Chapter 5

### Conclusion and Future Work

In this paper we have performed experiments on a novel approach to predict the stock prices using information from both numerical analysis and textual analysis. The numerical analysis was performed using LSTM model with a sliding window. This resulted in a MSE of 0.000453821, whereas the base model built using SVM resulted in an MSE of 0.0007262213. Then textual analysis was performed on the news articles which resulted in 78% accuracy in predicting their influence on the stock prices. When the results from textual analysis are augmented over the predictions from numerical analysis, the model resulted in 0.00037560132 MSE. We observe that adding textual information from news to the stock price data could greatly improve the prediction accuracy. Also, we see a substantial scope of enhancing this technique.

Results of numerical analysis can be improved by using more sophisticated approaches. For example, Wei Bao, et al. [16] presented a novel deep learning framework where stacked auto encoders, long-short term and wavelet transforms (WT) are used together for stock price prediction. Better results can be achieved by decomposing the time series using wavelet transforms to eliminate noise, then SAEs can be applied for generation of deep high-level features. Also, in textual analysis, we have chosen a classification model which outputs a binary result denoting whether the stock price would rise or fall. But this model does not predict how much influence the news has. By converting it into a regression problem where the model is able to predict the influence of a news using a numerical value, we may expect to achieve better results.

## References

- [1] T. Finley and T. Joachims, "Training structural SVMs when exact inference is intractable," in *25th international conference on Machine learning*, Helsinki, Finland, 2008.
- [2] Y. S. X. Z. Y. Ding, "Forecasting financial condition of chinese listed companies based on support vector machine," *Expert Syst. Appl*, vol. 34, no. 4, pp. 3081-3089, 2008.
- [3] H. N. I. H. M. K. A. S. Khalid Alkhatib, "Stock Price Prediction Using K-Nearest Neighbor (kNN) Algorithm".
- [4] A. N. Refenes, A. Zapranis and G. Francis, "Stock performance modeling using neural networks: a comparative study with regression models," *Neural Networks*, vol. 7, no. 2, pp. 375-388, 1994.
- [5] "Understanding Support Vector Machines," [Online]. Available: <https://www.analyticsvidhya.com/blog/2017/09/understaing-support-vector-machine-example-code/>.
- [6] H. G. J. H. Yuling Lin, "An SVM-based approach for stock market trend prediction," in *Proceedings of the International Joint Conference on Neural Networks*, Dallas, TX, 2013.



- [7] " Sample of a feed-forward neural network," [Online]. Available: [https://www.researchgate.net/figure/Sample-of-a-feed-forward-neural-network\\_fig1\\_234055177](https://www.researchgate.net/figure/Sample-of-a-feed-forward-neural-network_fig1_234055177).
- [8] "Recurrent neural Network - Wikipedia," [Online]. Available: [https://en.wikipedia.org/wiki/Recurrent\\_neural\\_network](https://en.wikipedia.org/wiki/Recurrent_neural_network).
- [9] S. Hochreiter, "The Vanishing Gradient Problem During Learning Recurrent Neural Nets and Problem Solutions," *International Journal of Uncertainty, Fuzziness and Knowledge-Based Systems*, vol. 06, no. 02, 1998.
- [10] J. S. Sepp Hochreiter, "Long Short Term Memory," *Neural Computation*, vol. 9, no. 8, pp. 1735-1780, 1997.
- [11] "Understanding LSTM networks," [Online]. Available: <http://colah.github.io/posts/2015-08-Understanding-LSTMs/>.
- [12] "Recurrent neural network," [Online]. Available: [https://en.wikipedia.org/wiki/Recurrent\\_neural\\_network](https://en.wikipedia.org/wiki/Recurrent_neural_network).
- [13] F. J. P. Tom Fawcett, "Activity monitoring: Noticing interesting changes in behavior," in *Proceedings of 5th International Conference on Knowledge Discovery and Data Mining.*, 1999.
- [14] J. X. Y. e. a. Gabriel Pui Cheong Fung, "News sensitive stock trend prediction," in *6th Pacific-Asia Knowledge Discovery in Data Mining*, Beijing, 2002.

- [15] M. D. S. D. L. P. O. D. J. J. A. Victor Larvenko, "Mining og concurrent text and time series," in *Workshop of 6th International Conference on Knowledge Discovery and Data Mining*, 2000.
- [16] W. Bao, J. Yue and Y. Rao, "A deep learning framework for financial time series using stacked autoencoders and longshort term memory," *PLoS ONE*, vol. 12, no. 7, 2017.
- [17] P. C. Fung, X. Yu and W. Lam, "Stock Prediction: Integrating Text Mining Approach using Real-Time News," in *Computational Intelligence for Financial Engineering*, Hong Kong, 2003.
- [18] T. Fawcett and F. J. Provost, "Activity monitoring: Noticing interesting changes in behavior," in *5th Intemational Conference on Knowledge Discovery and Data Mining*, New York, NY, 1999.
- [19] B. D. T. Yahya Eru Cakra, "Stock Price Prediction using Linear Regression based on Sentiment Analysis".
- [20] K. A. A. Devitt, "Sentiment polarity identification in financial news: A cohesion-based approach, Proceedings of the 45th Annual Meeting of the Association of Computational Linguistics (ACL-07), pp. 984-991, June 2007.".
- [21] "Prediction with LSTM," [Online]. Available: <https://lilianweng.github.io/lil-log/2017/07/08/predict-stock-prices-using-RNN-part-1.html>.
- [22] "Deep learning for complete beginners: convolutional neural networks with keras," [Online]. Available:

<https://cambridgespark.com/content/tutorials/convolutional-neural-networks-with-keras/index.html>.

- [23] W. L. Shaosheng Cao, "Improving Word Embeddings with Convolutional".
- [24] "A Beginner's Guide To Understanding Convolutional Neural Networks," [Online]. Available: <https://adeshpande3.github.io/A-Beginner%27s-Guide-To-Understanding-Convolutional-Neural-Networks/>.
- [25] "What does it mean by 1D convolutional neural network? - Quora," [Online]. Available: <https://www.quora.com/What-does-it-mean-by-1D-convolutional-neural-network>.
- [26] "Kaggle Stock News Dataset," [Online]. Available: <https://www.kaggle.com/aaron7sun/stocknews..>
- [27] "UCI - News Aggregator Dataset," [Online]. Available: <http://archive.ics.uci.edu/ml/datasets/News+Aggregator>.
- [28] C.-L. Huang and C.-Y. Tsai, "A hybrid SOFM-SVR with a filter-based feature selection for stock market forecasting," *Expert Systems with Applications*, vol. 36, no. 2, pp. 1529-1539, March 2009.
- [29] S. Thawornwong, "The adaptive selection of financial and economic variables for use with artificial neural networks," *Neurocomputing*, vol. 56, no. 1, pp. 205-232, 2004.

- [30] C.-F. Tsai and Y.-C. Hsiao, "Combining multiple feature selection methods for stock prediction: Union, intersection, and multi-intersection approaches," *Decision Support Systems*, vol. 50, no. 1, pp. 258-269, 2010.
- [31] C.-F. Tsai and Y.-C. Lin, "Predicting stock returns by classifier ensembles," *Applied Soft Computing*, vol. 11, no. 2, pp. 2452-2459, 2011.
- [32] M.-C. Lee, "Using support vector machine with a hybrid feature selection method to the stock trend prediction," *Expert Systems with Applications*, vol. 36, no. 8, pp. 10896-10904, 2009.
- [33] E. L. a. E. K. S. Bird, *Natural Language Processing with Python*, O'Reilly Media Inc., 2009.