

Available online at www.sciencedirect.com**ScienceDirect**

Procedia CIRP 69 (2018) 218 – 223

www.elsevier.com/locate/procedia

25th CIRP Life Cycle Engineering (LCE) Conference, 30 April – 2 May 2018, Copenhagen, Denmark

LCA and BIM: Integrated assessment and visualization of building elements' embodied impacts for design guidance in early stages

Martin Röck^a, Alexander Hollberg^b, Guillaume Habert^b, Alexander Passer^{a*}^a Working Group Sustainable Construction, Institute of Technology and Testing of Construction Materials, TU Graz, Inffeldgasse 24, 8010 Graz^b Chair of Sustainable Construction, Institute of Construction and Infrastructure Management, ETH Zurich, Stefano-Franscini-Platz 5, 8093 Zürich* Corresponding author. Tel.: +43 316 873 7153; E-mail address: alexander.passer@tugraz.at

Abstract

The importance of evaluation and improvement of life cycle performance of buildings in early design stages is widely acknowledged, the wide application of Life Cycle Assessment (LCA) however, is restrained by big uncertainty in design and material decisions at this stage. The approach presented in this paper aims to provide a proof-of-concept for an integrated assessment of the environmental impact of building construction using Building Information Modeling (BIM). To support decision-making in the critical early design stages, we propose a workflow of using conceptual BIM models and visual scripting to test a wide variety of possible construction options. The overall effects on the building's total impact are calculated for the various options to identify design specific hotspots. Different aspects of the results can be visualized to support intuitive design guidance.

© 2018 The Authors. Published by Elsevier B.V. This is an open access article under the CC BY-NC-ND license

[\(http://creativecommons.org/licenses/by-nc-nd/4.0/\)](http://creativecommons.org/licenses/by-nc-nd/4.0/).

Peer-review under responsibility of the scientific committee of the 25th CIRP Life Cycle Engineering (LCE) Conference

Keywords: Life Cycle Assessment; Building Information Modeling; Embodied Impacts; Integration; Visualisation; Design Guidance

1. Introduction

The built environment is commonly recognized as a major contributor to global environmental impacts. It consumes up to 40% of all raw materials extracted from the lithosphere and is responsible for roughly 50% of global greenhouse gas emissions. Therefore, international goals to mitigate related problems of climate change, loss of biodiversity, and other environmental impacts require ambitious improvements in environmental performance of the built environment [1,2].

To evaluate and improve building performance the Life Cycle Assessment (LCA) method has been widely accepted and is at the core of current standards for building sustainability assessment. Measures to document and reduce the environmental impact of the construction sector range from product specific certification schemes and labels to target values and regulatory benchmarks for buildings in some countries. [3,4].

Until recently, main focus was put on the operational stage of the building life cycle, accompanied by an increase of embodied impacts of building construction. As significant research effort has been directed to building energy simulation for improved energy efficiency levels, the amount of embodied energy in current high-performance buildings went up considerably. As recent studies on embodied impacts in building materials show a 'carbon spike' from material sourcing and production able to exhaust carbon budgets available for mitigation until 2050, the focus in research and policies is shifting towards earlier life cycle stages to establish a full picture of the environmental impacts of the construction sector [5–11].

The importance of evaluation and improvement of life cycle performance of buildings in early design stages is widely acknowledged, the wide application of LCA however, is restrained by big uncertainty in design and material decisions at this stage. LCA, being a data intensive methodology, requires a

high level of information, especially for the assessment of building materials' embodied impacts. It is therefore mostly used once the construction is built and all information clear, limiting the application of the method to being only descriptive ex-post, rather than providing feedback to improve the building design [12–17].

Thus the interest of researchers doing building LCA, is increasingly to integrate LCA in the building design process as soon as possible to provide design guidance and monitor the effect of design decisions [12,14]. To enhance the application of LCA in early design stages, an easy application with feasible effort is required that enables evaluation and comparison of building design options. LCA application can create added value, if supporting identification of the major contributing building elements to improve the design in an early stage. An integrated workflow could even be used to document how design decisions influence the overall result on the building level. Reliable and user-friendly LCA-tools that support a comprehensible communication of results are important for improving the wide applicability of the LCA method in the building design process [18,19].

To support an efficient and user-friendly application in early design stages, strategies for simplification in LCA have been proposed in several studies, taking different approaches towards a simplified yet representative assessment. Some studies are seeking to identify correlation between the various environmental impact to eventually make LCA more accessible and improve applicability to the building sector [20]. Other researchers investigated ways to aggregate LCA data on various levels or analyzed multiple LCA studies trying to derive empirical values representative for the environmental impact of specific building types. While general conclusions of embodied impacts for certain typologies on building level (e.g. impact per net/gross floor area) therein show to be not statistical reliable, aggregating LCA data on building element level could provide a precise and feasible approach for LCA of buildings in early design stages [21–25].

In recent years the use of Building Information Modeling (BIM) promises to support complex decision making through the integration and connection of different aspects and stakeholders. As various disciplines involved in building construction move towards BIM application, also LCA will require BIM-integrated workflows to support complex sustainable decision making in the future [19]. So far, researchers have used BIM-tools mainly to extract quantities to establish the Life Cycle Inventory (LCI) for LCA. However, most studies using BIM to conduct LCA during early design stages have faced the same problem as the LCA done without BIM: the level of geometry and information necessary for LCA is not yet available in the model. Thus, an assessment is still complex and time-consuming. Most BIM-LCA studies carry out a one-time, ex-post assessment, but not an integrated iterative assessment during building design [16,26].

Several approaches towards an application of BIM and LCA have been developed [14,16,26,27], however an integration providing the calculation of impacts and visual guidance in the design process within BIM has not been shown. At the same

time other recent studies have taken a parametric approach for the assessment of conceptual building designs using parametric modeling tools, proving the potential of algorithmic optimization of conceptual building design outside of BIM [28].

The approach presented in this paper aims to provide a proof-of-concept for a BIM-integrated assessment of the environmental impact of building construction in early design stages. To support decision-making in the critical early stages, we offer a workflow of using conceptual BIM models to test a wide variety of possible construction options. The overall effects on the building's total impact are calculated for the various options and different aspects of the results are visualized to support intuitive design guidance.

The goal of this paper is to show how an assessment of embodied impacts integrated in BIM can give architects and designers the freedom to focus on conceptual design while keeping track of the potential effects of design and material decisions.

2. Methodological framework

2.1. Common granularity in LCA and BIM

As in early design stages BIM models generally only provide a low Level of Geometry (LOG) [29,30] the common granularity for information on BIM elements and LCI data is specified on the level of *building elements* following a modular approach (Fig. 1). Also LCA data is aggregated on this level based on elements' predefined material composition [22,31]. This approach allows to conduct a comprehensible LCA of a buildings construction based on the low LOG of early stage BIM models.

2.2. LCA data of building elements

LCA datasets pre-calculated on the level of building elements can be obtained from several sources. The presented workflow utilizes Swiss SIA MB 2032 to establish a spreadsheet-based library of potential construction options and their embodied impacts per m² of building element (m²_{BE}) [3,4]. This library contains aggregated information on the embodied impacts of certain types of building sub-elements (e.g. structural layers of walls and floors, insulation and finishing

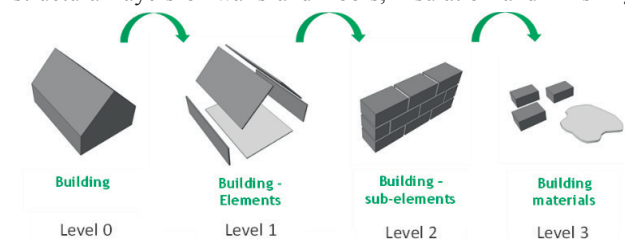

Fig. 1. Modular approach for aggregation of LCA acc. [39]

layers as well as windows and doors, etc.) based on the building materials contained therein. *Construction options* for building elements were calculated based on all available combinations of options for the respective sub-elements, e.g. External walls are a combination of: external layers including insulation; the structural layer(s); and the interior finishing. The establishment of such a project specific building element library is in line with preparatory measures suggested by various international BIM-specific guidelines and standards.

2.3. Common structure and naming convention

To exchange LCA and BIM data effectively a “common language” was specified and introduced to the spreadsheet-based element library as well as to the objects in the BIM model. The common naming convention applied in this study is based on the Swiss building element classification scheme for cost estimation eBKP-H and the element *codes* used therein.

While organizing the spreadsheet-based building element library according to this common naming convention through additional columns is straight forward, additional *custom parameters* were introduced to the Revit BIM model for this purpose. Parameters were added on *type* level for the respective object *categories* before specific values could be assigned to indicate the respective name of the building element class (e.g. code “C2.1x” for BIM objects representing “External walls”). This preparatory step is required to automate the process of identification and mapping of building element types and properties from the BIM model with respective impact values from the building element library.

2.4. Automated link of LCA and BIM

To establish an automated, bidirectional link between the building element library in Microsoft Excel and the BIM model in Autodesk Revit a script was developed in Autodesk Dynamo.

Fig. 2 shows the elements of this LCA-BIM integration. The BIM model therein provides a design-specific bill of quantities and properties for the various building elements (e.g. amount, area and geometry), while the building element library provides

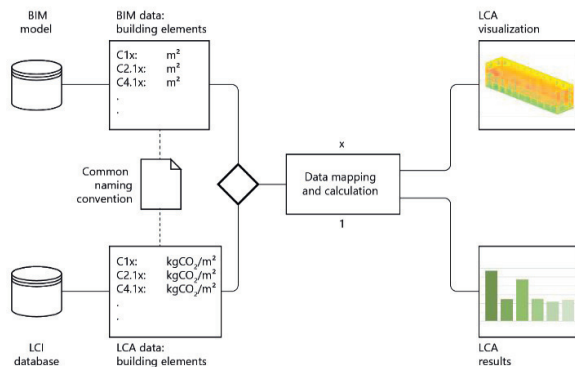

Fig. 2. Workflow scheme of the proposed LCA-BIM integration

information on the embodied impact for these elements. Both databases are structured following a common naming convention to support the automated extraction, mapping and processing in Dynamo. Impact values per m^2_{BE} for the different construction options were calculated directly in the building element library spreadsheet and are automatically extracted from there using the Dynamo script. The analysis of the construction options impact per m^2_{BE} regarding average values, standard deviation, etc. was also done in the spreadsheet for easy use, but could as well be done in Dynamo in the future. Already now the total embodied impact of the building for different construction options is calculated in Dynamo through multiplication of total area [m^2] of building elements obtained from the BIM model and the respective impact values per m^2_{BE} (average, deviation, etc.) from the building element library.

As the objects in the BIM model were identified and building element-specific impacts available, the workflow was further developed to enable a visualization of relevant information by color-coding the objects’ geometry in a 3D view of the digital building model based on information from both, the building element library as well as the values calculated within Dynamo.

3. Results from application on case study

3.1. Presentation of BIM case study

The proposed approach was tested on the conceptual BIM model of a residential building design, which was created in Autodesk Revit with LOG 200. Elements included in the BIM model were: foundation slab, external walls, floor and roof elements as well as windows and partition walls. After introducing the required type parameters as well as naming objects in the BIM model accordingly, the relevant elements could be automatically identified and element areas (m^2_{BE}) as well as the gross floor area (m^2_{GFA}) of the building could be extracted through the developed Dynamo script (see. Table 1).

Building element classes and area (m^2)						GFA (m^2)
383.2	569.0	690.4	363.5	348.6	902.1	1149.5
C 1x	C 2.1x	C 4.1x	C 4.4x	E 3x	G 1x	-
Foundations	Ext. walls	Floors	Roofs	Windows	Partit. walls	-

3.2. Building element library with construction options

The aforementioned building element library with information on embodied impacts was established based on building elements of SIA MB 2032 (See Annex 9 of [3]). In total 1713 different combinations of potential *construction options* were established for the various building element classes as explained in section 2.2. This information on the embodied impact of building elements’ potential construction

options was then processed in Dynamo to calculate the resulting potential impacts of each building element class and thus the building construction’s potential total impact. Details on the composition of construction options as well as their embodied impacts can be found in the Appendix A.1.

3.3. Calculation and analysis of total impact

Applying the presented workflow an integrated calculation of the total embodied impact on building level could be calculated and the (potential) contribution and relevance of individual building element classes could be identified. Embodied environmental impacts are in the following exemplarily presented as Global Warming Potential (GWP) per m^2_{GFA} (i.e. annual share per year of Reference Service Period (RSP)).

Fig. 3 shows the contribution of the different building element classes for all possibly construction options (calculated as described in 3.2). We can see that on average (blue continuous line) floors (C4.1x) and external walls (C2.1x) as well as partition walls (G 1x) are the main contributors to embodied GWP while the other element classes have significantly lower and quite similar impacts on average. Also it can be observed that deviation in impact of different construction options (grey box and whiskers) is highest for these three element classes. While a high sensitivity of the total result towards the construction option chosen for external walls and floors could be expected, the potentially high contribution from partition walls indicates the surprising relevance of this element class in the context of the presented building case.

3.4. Visualization of LCA results

Using the proposed workflow, the contribution as well as other aspects of the results could be visualized in 3D views of the building model. To inform designers about potential improvements by choosing different construction options, it is important to know e.g. how much a specific element class could be improved, if at all. The visualization routine can be used to e.g. highlight elements and their deviation from the average impact for the construction options assessed as well as the effect

an improvement on one specific element class would have on the total result.

Fig. 4 presents the standard deviation (SDEV) for impact contribution of each element class based on the assessed construction options for this class. We can see that the available construction alternatives for foundations, roofs, external walls and windows only offer low (green) to moderate (yellow) potential to improve the total building impact. In particular, the visualization shows that the total impact could be reduced (or increased) by 0.33 to approx. 0.60 $kgCO_2eq/m^2_{GFA}$ depending on the construction option chosen for these elements. The element classes of floors and partition walls however, have high deviation in impact of the assessed construction options. Thus, choosing an alternative construction option for these classes provides moderate to high potential (orange and red) for improving the overall building impact. Specifically, we can observe potential reduction (or increase) of up to 1.26 $kgCO_2eq/m^2_{GFA}$ from these element classes. Note that these values are based on standard deviation and thus impacts could even be lower (or higher) when choosing the extreme the impact construction options. However, the evaluation of the various possible construction options and the visualization of the results clearly show which elements should be given special focus in further design decisions.

4. Discussion

The workflow presented in this paper enabled the exchange and processing of information from the BIM model and the established building element library. This supports an integrated calculation of total embodied impacts and identification of the contribution and potential improvements of specific building element classes, within a BIM environment.

Furthermore, this information can be matched with the elements’ geometries in the BIM model to support a visualization of embodied impacts and potential improvements for visual design guidance in early stage.

Requirements for this approach were a common granularity in both LCA data and BIM elements as well as a common naming of elements to support the automated exchange and processing within Dynamo.

The assessment results presented as well as the conclusions drawn from them should not be generalized as they depend on

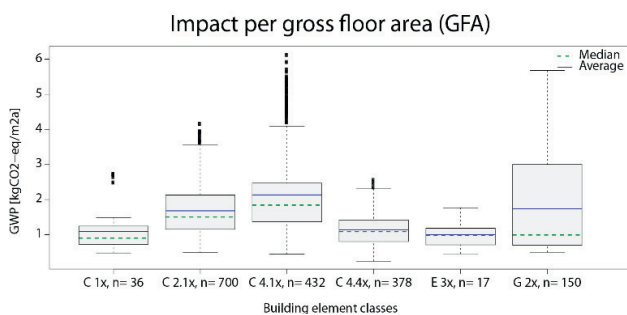

Fig. 3. Total embodied impact per building element class (GWP/m²GFAa)

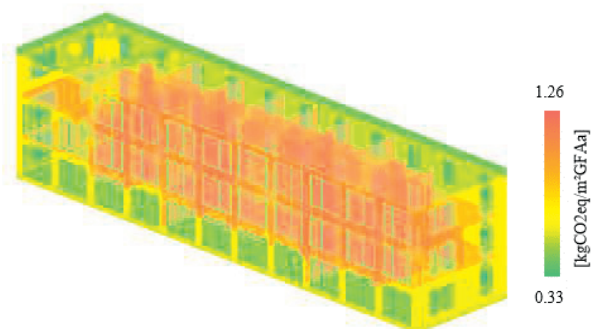

Fig. 4. Deviation (SDEV) of contribution to total building impact

the quality of input data from both BIM model (e.g. model completeness and accuracy) and LCA data [32]. It should be noted that for the illustrated BIM integrated LCA workflow, the quality of the LCA background data, as well as inherent uncertainty, must be considered in order to achieve representative and comparable results [32–34]. All studies on LCA's uncertainties are therefore also relevant and could be applied to this study. Further studies on LCA uncertainty and hot spots at building level can benefit from an integrated assessment workflow as presented in this paper.

The future application of BIM integrated LCA could further be combined with dynamic energy simulation and parametric optimization and evolved by implementing multi-criteria decision making to manage interdependencies between the various environmental impact drivers in the building context [35–37]. Furthermore, the assessment could be closer integrated into BIM-based planning processes e.g. through integration of product specific information on environmental impacts (e.g. EPD or PEF) in the tender stage – an aspect specifically important in the context of evolving Green Public Procurement (GPP) policies [38].

5. Conclusion

The presented workflow shows that it is possible to accomplish an integration of LCA in BIM when using a common granularity in both, LCA data and BIM-based bill of quantities as well as specifying a common naming convention.

Applying this approach allows to have a BIM-integrated calculation of embodied impacts for different design and construction options in early design stages.

Using a variety of potential construction options this integrated calculation furthermore enables a detailed analysis of individual building element's contribution to the total impact and the identification of design-specific hotspots.

Finally, the building model geometry can be used for visual design guidance by presenting various aspects in an intuitive way using the BIM models 3D views.

This shall make the application of LCA more accessible and improve assessment and communication of embodied impacts within future design practice.

Appendix

A.1. Details on the construction options

Table 2 shows how the different construction options for building elements were calculated based on the possible combinations of elements provided in SIA MB 2032 [3].

While the results for these construction options presented in Fig. 5, show that the average of impact per m² of building element is similar, considerable variance in impacts and extreme values of different element classes can be observed. For example, building element class G 1x (Partition walls) shows a significantly lower average and median value than the other building elements. At the same time C 2.1x (External

walls), while having unremarkable average and mean values, shows a significant number and amplitude of extreme values.

Table 2. Construction options for buildings elements based on combinations of elements

Code	C 1x	C 2.1x	C 4.1x	C 4.4x	E 3x	G 1x
Building element class	Foundations	Ext. walls	Floors	Roofs	Windows	Partit. walls
Building sub-elements	C1 + G2	C2.1B + E2 + G3	C4.1 + G2 + G4	C4.4 + G4 + F1	E 3	G3 + G1 + G3
No. of options	36	700	432	378	17	150

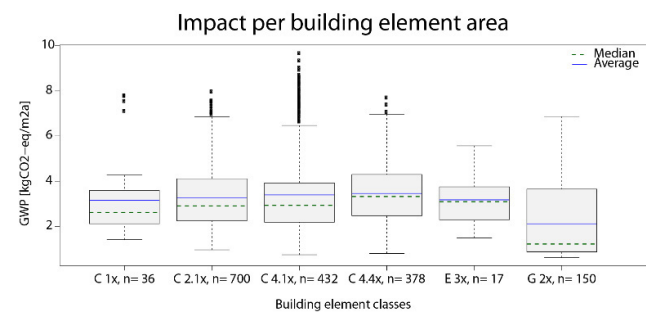

Fig. 5. Comparison of impact per m² building element for all construction options

References

- [1] Savaresi A. The Paris Agreement: a new beginning? *J Energy Nat Resour Law* 2016;34:16–26.
- [2] de Jong M, Joss S, Schraven D, Zhan C, Weijnen M. Sustainable–smart–resilient–low carbon–eco–knowledge cities; making sense of a multitude of concepts promoting sustainable urbanization. *J Clean Prod* 2015;24. doi:10.1016/j.jclepro.2015.02.004.
- [3] Kellenberger D, Ménard M, Schneider S, Hänger M, Org M, Victor K, et al. Arealentwicklung für die 2000-Watt-Gesellschaft: Beurteilungsmethode in Anlehnung an den SIA-Effizienzpfad Energie. 2012.
- [4] Pfäffli K, Preisig H. SIA Effizienzpfad Energie 2010.
- [5] Chong HY, Lee CY, Wang X. A mixed review of the adoption of Building Information Modelling (BIM) for sustainability. *J Clean Prod* 2017;142:4114–26. doi:10.1016/j.jclepro.2016.09.222.
- [6] Kota S, Haberl JS, Clayton MJ, Yan W. Building Information Modeling (BIM)-based daylighting simulation and analysis. *Energy Build* 2014;81:391–403. doi:10.1016/j.enbuild.2014.06.043.
- [7] Kensek K. Visual Programming for Building Information Modeling: Energy and Shading Analysis Case Studies. *J Greenbuilding* 2015;10:28–43.
- [8] Ahn KU, Kim YJ, Park CS, Kim I, Lee K. BIM interface for full vs. semi-automated building energy simulation. *Energy Build* 2014;68:671–8. doi:10.1016/j.enbuild.2013.08.063.
- [9] Balouktsi M, Lützkendorf T. Energy Efficiency of Buildings: The

- Aspect of Embodied Energy. *Energy Technol* 2016;4:31–43. doi:10.1002/ente.201500265.
- [10] Balouktsi M. Embodied impacts in stakeholder decision - making in the construction sector 2016.
- [11] Malmqvist T, Birgisdottir H, Aoife HW, Moncaster A, John V, Passer A, et al. Design strategies for low embodied energy and greenhouse gases in buildings: analyses of the IEA Annex 57 case studies. *World Sustain. Build. Conf. 2014 - Conf. Proc.*, 2014, p. 47–47.
- [12] Anand CK, Amor B. Recent developments, future challenges and new research directions in LCA of buildings: A critical review. *Renew Sustain Energy Rev* 2017;67:408–16. doi:10.1016/j.rser.2016.09.058.
- [13] Soust-Verdaguer B, Llatas C, Garcia-Martínez A. Simplification in life cycle assessment of single-family houses: A review of recent developments. *Build Environ* 2016;103:215–27. doi:10.1016/j.buildenv.2016.04.014.
- [14] Soust-Verdaguer B, Llatas C, García-Martínez A. Critical review of bim-based LCA method to buildings. *Energy Build* 2017;136:110–20. doi:10.1016/j.enbuild.2016.12.009.
- [15] Jalaei F, Jrade A. An automated BIM model to conceptually design, analyze, simulate and assess sustainable building projects. *J Constr Eng* 2014;2014:1–21. doi:10.1155/2014/672896.
- [16] Basbagill J, Flager F, Lepech M, Fischer M. Application of life-cycle assessment to early stage building design for reduced embodied environmental impacts. *Build Environ* 2013;60:81–92. doi:10.1016/j.buildenv.2012.11.009.
- [17] Häkkinen T, Kuittinen M, Ruuska A, Jung N. Reducing embodied carbon during the design process of buildings. *J Build Eng* 2015;4:13.
- [18] Zanni MA, Soetanto R, Ruikar K. Towards a BIM-enabled sustainable building design process: roles, responsibilities, and requirements. *Archit Eng Des Manag* 2017;13:101–29. doi:10.1080/17452007.2016.1213153.
- [19] Eleftheriadis S, Mumovic D, Greening P. Life cycle energy efficiency in building structures: A review of current developments and future outlooks based on BIM capabilities. *Renew Sustain Energy Rev* 2017;67:811–25. doi:10.1016/j.rser.2016.09.028.
- [20] Lasvaux S, Achim F, Garat P, Peuportier B, Chevalier J, Habert G. Correlations in Life Cycle Impact Assessment methods (LCIA) and indicators for construction materials: What matters? *Ecol Indic* 2016;67:174–82. doi:10.1016/j.ecolind.2016.01.056.
- [21] Kellenberger D, Althaus H-J. Relevance of simplifications in LCA of building components. *Build Environ* 2009;44:818–25. doi:10.1016/j.buildenv.2008.06.002.
- [22] Marsh R. LCA profiles for building components: strategies for the early design process. *Build Res Inf* 2016;44:358–75. doi:10.1080/09613218.2016.1102013.
- [23] John V. Derivation of reliable simplification strategies for the comparative LCA of individual and “typical” newly built Swiss apartment buildings 2012. doi:dx.doi.org/10.3929/ethz-a-007607252.
- [24] Rossi B, Marique A-F, Glaumann M, Reiter S. Life-cycle assessment of residential buildings in three different European locations, basic tool. *Build Environ* 2012;51:395–401. doi:10.1016/j.buildenv.2011.11.017.
- [25] Zabalza Bribián I, Aranda Usón A, Scarpellini S. Life cycle assessment in buildings: State-of-the-art and simplified LCA methodology as a complement for building certification. *Build Environ* 2009;44:2510–20. doi:10.1016/j.buildenv.2009.05.001.
- [26] Malmqvist T, Birgisdottir H, Houlihan Wiberg A, Moncaster A, Brown N, John V, et al. Design strategies for low embodied energy and greenhouse gases in buildings : analyses of the IEA Annex 57 case studies. *World Sustain. Build. Conf.*, Barcelona: 2014, p. 8–16.
- [27] Houlihan Wiberg A, Georges L, Dokka TH, Haase M, Time B, Lien AG, et al. A net zero emission concept analysis of a single-family house. *Energy Build* 2014;74:101–10. doi:10.1016/j.enbuild.2014.01.037.
- [28] Hollberg A, Ruth J. LCA in building design – A parametric approach. *Int J Life Cycle Assess* 2016;forthcomin.
- [29] BIMForum. Level of Development Specification. *BIM Forum* 2015:195.
- [30] Claus Maier. *Building Information Modeling - Grundzüge einer open BIM Methodik für die Schweiz*. 2015.
- [31] Trigaux D, Oosterbosch B, De Troyer F, Allacker K. A design tool to assess the heating energy demand and the associated financial and environmental impact in neighbourhoods. *Energy Build* 2017;152:516–23. doi:10.1016/j.enbuild.2017.07.057.
- [32] Häfliger IF, John V, Passer A, Lasvaux S, Hoxha E, Saade MRM, et al. Buildings environmental impacts’ sensitivity related to LCA modelling choices of construction materials. *J Clean Prod* 2017;156:805–16. doi:10.1016/j.jclepro.2017.04.052.
- [33] Hoxha E, Habert G, Chevalier J, Bazzana M, Le Roy R. Method to analyse the contribution of material’s sensitivity in buildings’ environmental impact. *J Clean Prod* 2013;66:54–64. doi:10.1016/j.jclepro.2013.10.056.
- [34] Hoxha E, Habert G, Lasvaux S, Chevalier J, Le Roy R. Influence of construction material uncertainties on residential building LCA reliability. *J Clean Prod* 2017;144:33–47. doi:10.1016/j.jclepro.2016.12.068.
- [35] Heeren N, Mutel CL, Steubing B, Ostermeyer Y, Wallbaum H, Hellweg S. *Environmental Impact of Buildings □ What Matters?* 2015. doi:10.1021/acs.est.5b01735.
- [36] Hollberg A, Ruth J. LCA in architectural design—a parametric approach. *Int J Life Cycle Assess* 2016. doi:10.1007/s11367-016-1065-1.
- [37] Kreiner H et al. A new systemic approach to improve the sustainability performance of office buildings in the early design stage. *Energy Build* 2015;109:385–96. doi:10.1016/j.enbuild.2015.09.040.
- [38] Passer A, Lasvaux S, Allacker K, Lathauwer D De, Wall J, Spirinckx C, et al. Environmental Product Declarations entering the building sector - critical reflections based on 5 years experience in different European countries. *Int J Life Cycle Assess* 2015.
- [39] Trigaux D, Wijnants L, De Troyer F, Allacker K. Life cycle assessment and life cycle costing of road infrastructure in residential neighbourhoods. *Int J Life Cycle Assess* 2017;22:938–51. doi:10.1007/s11367-016-1190-x.