

Title	A geiger-mode APD photon counting system with adjustable dead-time and interchangeable detector
Author(s)	Deng, Shijie; Gordon, Declan; Morrison, Alan P.
Publication date	2016-01-01
Original citation	Deng, S., Gordon, D. and Morrison, A. P. (2016) 'A Geiger-Mode APD Photon Counting System With Adjustable Dead-Time and Interchangeable Detector', IEEE Photonics Technology Letters, 28(1), pp. 99-102. doi: 10.1109/LPT.2015.2487342
Type of publication	Article (peer-reviewed)
Link to publisher's version	https://ieeexplore.ieee.org/document/7289373/ http://dx.doi.org/10.1109/LPT.2015.2487342 Access to the full text of the published version may require a subscription.
Rights	© 2015 IEEE. Personal use of this material is permitted. Permission from IEEE must be obtained for all other uses, in any current or future media, including reprinting/republishing this material for advertising or promotional purposes, creating new collective works, for resale or redistribution to servers or lists, or reuse of any copyrighted component of this work in other works.
Item downloaded from	http://hdl.handle.net/10468/6389

Downloaded on 2019-01-07T06:02:39Z

A Geiger-mode APD photon counting system with adjustable dead-time and interchangeable detector

Shijie Deng, Declan Gordon and Alan P. Morrison, Senior Member, IEEE

Abstract—A Geiger-mode avalanche photodiode (GM-APD) photon counting system is presented in this paper. The system provides a maximum counting rate of 35 Mcounts/s and is capable of directly displaying the counting rate and data logging to a PC. In this system, the detector can be easily changed to enhance its usefulness in different applications. A novel active quench and reset integrated circuit (AQR-IC) is designed for the system with adjustable hold-off time from several nanoseconds up to 1.6 μ s with a setting resolution of about 6.5 ns. This facilitates optimal performance when using different types of APDs. The AQR-IC also registers each avalanche event as a TTL pulse that is processed by a micro-controller to calculate the photon-counting rate. The microcontroller can be interfaced with a PC over USB to record the measured data and to allow further processing. Software was also written to calculate the photon-counting rate, display the results and save the data to files.

Index Terms—Geiger-mode avalanche photodiode, Single photon counting, adjustable dead-time, photon-counting system.

I. INTRODUCTION

SINGLE photon counting techniques have been used in a myriad of low-light sensing applications requiring high-sensitivity such as LIDAR, DNA sequencing, quantum key distribution, and medical imaging. Historically photomultiplier tubes (PMTs) have been used for photon counting applications but improvements in GM-APD in recent years has led to this detector becoming more popular for single photon counting due to its lower operating voltages, lower-cost, higher sensitivity, smaller size and suitability for integration. A number of single photon counting modules using APDs have been developed [1-9]. The maximum photon-counting rate of these modules is typically from 10 to 20 Mcounts/s with some approaching 40 Mcounts/s. One limitation in these modules is that the detector is fixed and the hold-off time (and consequently dead-time) in the detector is difficult to change. The hold-off time is the time that the APD is kept in the OFF state following detection of an avalanche event to allow for the dissipation of trapped charges that may result in a false avalanche event being triggered. The hold-off time is realized

using an active quench and reset circuit to minimize this “afterpulsing” phenomenon. During the hold-off process, no incoming photon can be detected thereby limiting the maximum achievable counting rate of the GM-APD. As a result, a trade-off exists between the photon counting rate and an acceptable level of “afterpulsing”, therefore an accurate adjustment of the hold-off time is important in a single photon counting system. Depending on the purpose of the measurement (e.g. UV, visible or long wavelength), different types of APD will be required and different hold-off times should be set to optimise the APD’s performance characteristics. In [1-4] the hold-off time is fixed, in [5] the hold-off time can only be changed by factory setting and in [6] the hold-off time can only be adjusted in step-sizes > 100 ns. In [7-9], two delay modules are required (one for quenching and the other for resetting) to set the hold-off time. The adjustment of the delay module is complicated and adds to the control complexity for changing hold-off times.

In this work a complete GM-APD based single photon counting system is developed. The system is able to provide a maximum photon-counting rate of 35 Mcounts/s with interchangeable APD devices. An active quench and reset integrated circuit (AQR-IC) was designed that allows the hold-off time to be accurately set digitally from several nanoseconds up to 1.6 μ s with a resolution of about 6.5 ns. This allows the selection of the optimal ‘afterpulse-free’ hold-off time for the GM-APD via external digital inputs or additional signal processing circuitry. Unlike typical active quench and reset circuits that require two delay modules to set the hold-off time, this AQR-IC is designed to automatically reset the APD at the end of the hold-off period without the need for an extra delay module. The AQR-IC also converts the avalanche events that occur in the APD into TTL pulses that are sent to a micro-controller system for counting rate calculation. The micro-controller is programmed to collect the photon counting data and send the data to a PC through a USB cable. A C#/WPF software application was written to calculate the photon counting rate, have it displayed on a graphical user interface (GUI) and record the data in CSV files.

II. SYSTEM DESCRIPTION

Fig. 1 shows the block diagram of the photon counting system developed. It consists of 3 main parts: i. An active quench and reset integrated circuit (AQR-IC) that is used to accurately set the hold-off time in the APD and convert detected avalanche events into TTL pulses. A printed circuit board (PCB) is designed to hold the AQR-IC and a GM-APD; ii. A micro-controller system to collect the photon counting data and send it to a PC through a USB cable; iii. A software

This work was supported by Science Foundation Ireland under grant 07/SRC/H1173.

Shijie Deng is with the Centre for Advanced Photonics and Process Analysis (CAPPA), Cork Institute of Technology and Tyndall National Institute, Cork, Ireland (e-mail: shijie.deng@cit.ie).

Declan Gordon and Alan P. Morrison are with the Department of Electrical and Electronic Engineering, University College Cork, Cork, Ireland (e-mail: declang@rennes.ucc.ie, a.morrison@ucc.ie).

Copyright (c) 2015 IEEE. Personal use of this material is permitted. However, permission to use this material for any other purposes must be obtained from the IEEE by sending a request to pubs-permissions@ieee.org.

application including a graphical user interface (GUI) running on a PC to calculate and display the photon counting rate and save the data to files.

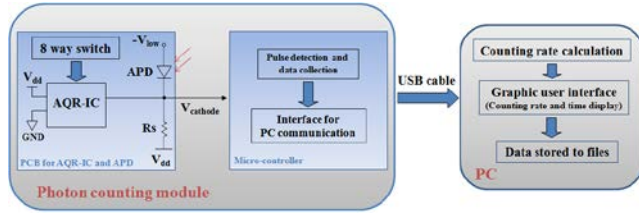

Fig. 1 Block diagram of the single photon counting system developed.

A. Active quench and reset circuit

Fig. 2 shows the schematic of the active quench and reset chip. In the circuit, a comparator is used to sense the avalanche current at the cathode of the GM-APD. The comparator's inverting input is connected to the cathode of a GM-APD, which is biased at a voltage determined by V_{dd} and $-V_{low}$. One PMOS and one NMOS transistor are used as the switches for quenching or resetting the APD. A ring-oscillator is used to generate clock pulses during the hold-off period and a counter is used to count the clock pulses to adjust the hold-off time [10].

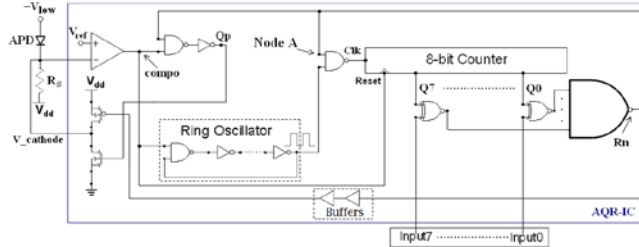

Fig. 2 Schematic of the active quench and reset IC.

The operation of the circuit is as follows: When there are no avalanche events, the output of the comparator "compo" is low, the ring-oscillator is inactive and the 8-bit counter is reset to 0 ("00000000"), both PMOS and NMOS transistors are turned off. When an avalanche event occurs, current flows through the sensing resistor R_s and a voltage drop can be seen at the cathode of the APD. The comparator senses the voltage drop and its output "compo" goes from low to high. Qp goes high to turn on the NMOS transistor and the cathode of the APD is connected to GND for quenching. Meanwhile, the ring oscillator is active and providing the clocks to the 8-bit counter. When the signal "compo" is high, the counter receives clock pulses generated by the ring-oscillator and starts counting upwards from 0 ("00000000") to 255 ("11111111"). Each output of the counter is connected to one input of an XNOR gate. The other input of the XNOR is connected to an external input (controlled by the user). When the outputs of the counter equal the external inputs, all the outputs of the XNOR gates go to logic "1" (high). Then Rn goes low which makes Qp go low to stop the hold-off process and turn on the PMOS transistor thus resetting the GM-APD bias voltage (buffers are used here to make sure the reset process starts after the hold-off process is finished). At this time, Node A goes low to block the clock from the ring-oscillator to the counter and the counter is stopped. This makes Rn remain low for resetting. When the cathode of the GM-APD is reset back to V_{dd} , "compo" is low, the ring-oscillator is inactive and the counter is reset to 0 ("00000000"). Now the outputs of the counter do not match the

external inputs, Rn goes high and the PMOS transistor is turned off to complete the reset process. The APD is then ready to detect the next avalanche event. By setting the external inputs, the counting number can be determined and the hold-off time can be altered. The step-size of the hold-off time is decided by the clock frequency and that depends on the number of the stages of the ring-oscillator. Each quenching and resetting process (avalanche event) generates one TTL pulse at the cathode of the APD ($V_{cathode}$), which is connected to the micro-controller system for calculating the photon counting rate.

B. Photon counting rate calculation and interface with PC

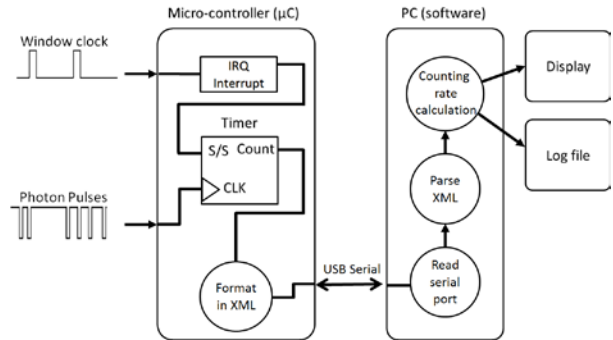

Fig. 3 block diagram of the photon counting rate calculation and interface.

A block diagram of the photon counting rate calculation and interface is shown in Fig. 3. An NXP LPC1768 microcontroller (μC) is used to implement the pulse counting functionality and data interface. The high clock speed of the microcontroller allows hardware counting at rates of up to 48 MHz. A PC is used to run the software (including a GUI) developed for graphically displaying the results and data logging.

In the microcontroller, a reconfigurable hardware timer module is used to detect the photon pulses from the photon counting module. The counting windows are defined by a clock signal: window clock. The total number of photon pulses between successive low to high events of the window clock are summed and converted into XML formatted data. The data is transmitted to a PC via a USB-Serial interface. A C#/WPF software application was written to parse the XML data, calculate, display and record the counting rate data. The application listens for new data on the serial port and parses the photon counting values from any received XML data. The counting rate values then are multiplied by the window clock frequency to give the photon counting rate over that window period. A graphical user interface displays the photon counting rate with a time stamp and logs the data to a file.

III. EXPERIMENTAL RESULTS

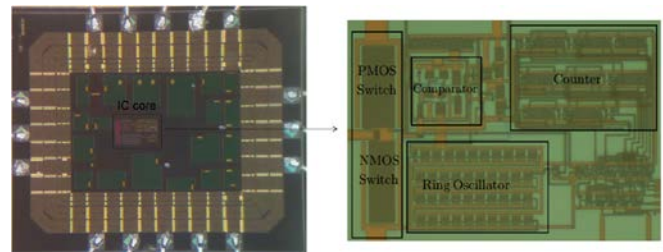

Fig. 4 Photograph of the fabricated AQR-IC.

The AQR-IC was fabricated with 0.35 μm AMS CMOS process. Fig. 4 shows the photographs of the fabricated chip, the overall chip dimension is 1.7 mm \times 1.4 mm which mostly occupied by the bond pads and decoupling capacitors. The dimensions of the IC core are 260 μm \times 150 μm .

A printed circuit board (PCB) was designed for housing the AQR-IC and the APD. On the PCB, a 24 pin ZIF socket is used to hold the packaged APD (see Fig. 5) to facilitate changing the APD to suit different applications (e.g. UV, visible or long wavelength light detection).

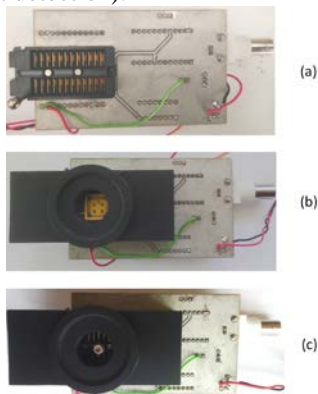

Fig. 5 Bottom-side of the test PCB (holding the APDs).

In the experiments, two APDs have been used. One APD (APD1) is a 20 μm diameter circular APD with a breakdown voltage of 27 V developed by the Photodetection and Imaging Group at University College Cork [11], [12], see Fig. 5(b). The other APD (APD2) is from FirstSensor, which has a breakdown voltage of 70 V [13], see Fig.5(c).

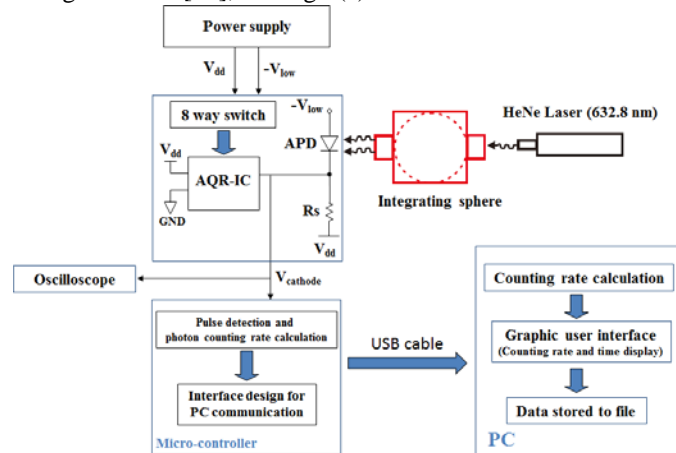

Fig. 6 Experimental setup for testing the photon counting system.

In Fig. 6, the experimental setup for the photon counting system is described. In the setup, a He-Ne laser source operating at 632.8 nm was used to illuminate the APD using an integrating sphere. An external power supply was used to provide $-V_{\text{low}}$ and V_{dd} for biasing the APD and powering the AQR-IC. The APD is biased around 3 V or 5 V (3 V for APD1 and 5 V for APD2) in excess of the breakdown voltage. The hold-off time is controlled by the 8-way switch on the PCB. An oscilloscope was used to observe the voltage at the cathode (V_{cathode}) of the APD. The cathode (V_{cathode}) of the APD is connected to an input pin of the microcontroller that collects the avalanche event data, calculates the photon counting rates and

reports the results to the PC through a USB cable. The graphical user interface (GUI) running in the PC displays the photon counting rate statistics and records the data to a file.

Fig. 7 demonstrates the oscilloscope traces of the cathode voltage (V_{cathode}) of the APDs tested with (a) the hold-off time kept at 80 ns by setting Input7 - Input0 to 00001100, V_{dd} set to 3.3 V for quenching excess voltage of up to 3.3 V. (b) the hold-off time kept at 542 ns by setting Input7 - Input0 to 01010111, V_{dd} set to 5 V for quenching excess voltage of up to 5 V. The results show the hold-off time can be precisely controlled. Results also show that the quenching time delay (time interval between the APD breakdown and lowering the APD bias below its breakdown) are about 9 ns and 13 ns for excess bias of 3 V and 5 V respectively. To shorten this interval time, two main options are: 1. Reduce the parasitic introduced by the connection between the APD and the quenching chip. A hybrid package of the APD and the quenching chip or fabricate the APD and the quenching chip on a same wafer will dramatically reduce the parasitic and shorten the delay time. However, this will limit the ability of inter-changing the detector. 2. To design a faster amplifier or comparator for detecting the avalanche events in the APD, that will shorten the delay time.

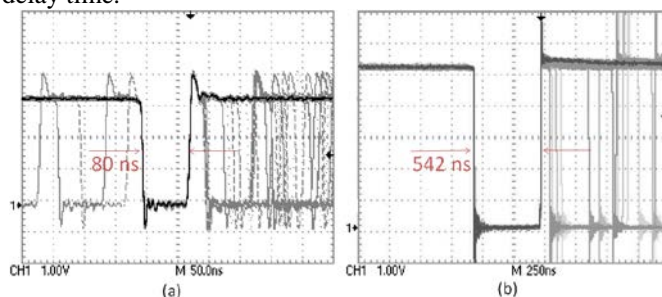

Fig. 7 (a) APD1's cathode voltage with the hold-off time kept at 80 ns by setting Input7 - Input0 to 00001100, V_{dd} set to 3.3 V for quenching excess voltage of up to 3.3 V. (b) APD2's cathode voltage with the hold-off time kept at 542 ns by setting Input7 - Input0 to 01010111, V_{dd} set to 5 V for quenching excess voltage of up to 5 V.

Fig. 8 shows the results of varying the external input codes versus the resultant hold-off time. It shows when the input code increases from 1 ("0000001") to 255 ("1111111") the hold-off time linearly increases from several nanoseconds to more than 1.6 μs with a setting step of about 6.5 ns. This allows the required hold-off time to be accurately set digitally to suit the individual properties of the APD used.

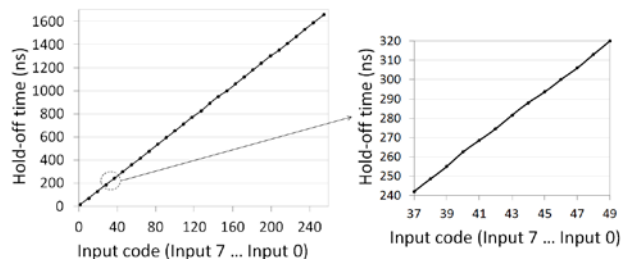

Fig. 8 External input codes versus hold-off time.

Fig. 9 shows the counting rates measured by the system for different incident laser powers when different hold-off times are set. Fig. 9(a) shows the results by using APD1 and Fig. 9(b) shows the results by using APD2. Results show that when the

minimum hold-off time (about 6.5 ns) is chosen, the maximum counting rate reaches about 35 Mcounts/s with saturated incident light. Results also show that shorter hold-off time provides higher dynamic range for the detection while longer hold-off time gives a lower noise level (dark count and afterpulsing). This trade-off exists between maximum counting rate and noise level and the accurate and easy control of the hold-off time is vital for making the choice.

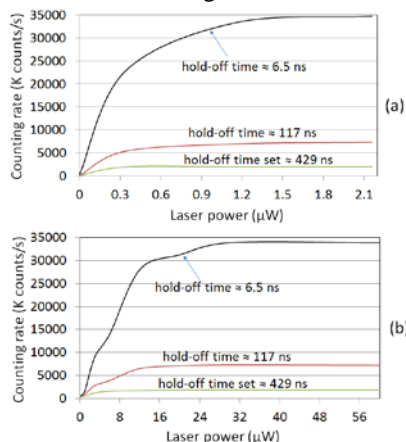

Fig. 9 Photon counting rates measured for different incident laser powers.

Fig. 10 shows the setup for measuring the timing jitter. A 632 nm pulsed laser was used to illuminate the APD (APD1 is used here with a dead-time set to about 46 ns) in the system and the propagation delay between the triggering of the laser and the triggering of the counting system's output is measured. An NIM signal converter is built here to convert the TTL signal from the counting system to a negative NIM logic which is connected to the stop pin on the B&H TCSPC module.

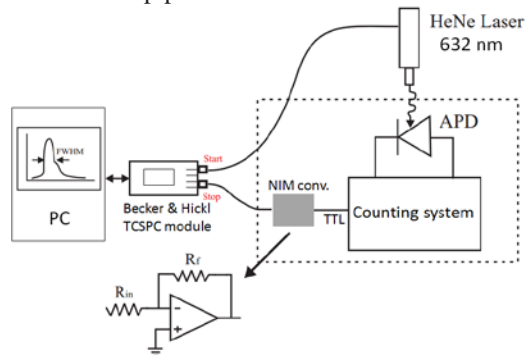

Fig. 10 Experimental setup for measuring timing response of the system.

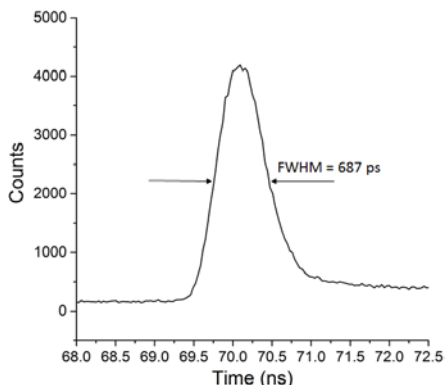

Fig. 11 Timing response of the counting system.

Fig. 11 shows the timing response of the counting system. The propagation delay here is caused by the parasitic between APD and the counting system and the speed of the op-amp used in the NIM converter. The timing jitter (FWHM) measured for the overall system is about 687 ps, which can be improved by better aligning the laser and the detector surface, decreasing the ambient light, cooling the APD and also introducing additional electronics.

IV. CONCLUSION

A complete single photon counting system that is capable of providing a maximum photon-counting rate of 35 Mcounts/s has been designed. In the system, an interchangeable APD device is used to detect the incident photons. An active quench and reset integrated circuit (AQR-IC) that enables accurate digital control of the hold-off time in the APD from several nanoseconds up to 1.6 μ s with a setting resolution of 6.5 ns is described. The AQR-IC designed also converts the avalanche events occur in the APD into TTL pulses, which are sent to a microcontroller system for photon counting rate calculation. The microcontroller is programmed to collect the photon counting data and send the data to a PC through a USB cable. A customised software application running on a PC is used to capture the photon counting date, calculate the photon counting statistics, display the results and store the recorded data to CSV files.

REFERENCES

- [1] <http://www.lasercomponents.com/uk/product/single-photon-counting-modules/>
- [2] <http://www.picoquant.com/products/category/photon-counting-detectors/pdm-series-single-photon-avalanche-diodes>
- [3] <http://www.thorlabs.de/thorproduct.cfm?partnumber=SPCM50A>.
- [4] <http://www.idquantique.com/photon-counting/photon-counting-modules/id100/>
- [5] <http://www.excelitas.com/Pages/Product/Single-Photon-Counting-Modules-SPCM.aspx>
- [6] <http://aureatechnology.net/en/our-tcspc-photon-counters.html>
- [7] Rosario Mita and Gaetano Palumbo, "High-Speed and Compact Quenching Circuit for Single-Photon Avalanche Diodes," *IEEE Trans. Instrum. Meas.*, vol. 57, no. 3, pp.543-547, 2008.
- [8] D. Cronin and A. P. Morrison, "Intelligent System for Optimal Hold-Off Time Selection in an Active Quench and Reset IC," *IEEE J. Sel. Topics Quantum Electron.*, vol.13, no.4, pp.911-918, Jul./Aug. 2007.
- [9] V.H. Dhulla, G. Gudkov, D. Gavrilov, A. Stepukhovich, A. Tsupryk, O. Kosobokova, A. Borodin, B. Gorbovitski and V. Gorfinkel, "Single Photon Counting Module Based on Large Area GM-APD and Novel Logic Circuit for Quench and Reset Pulse Generation," *IEEE J. Sel. Topics Quantum Electron.*, vol.13, no.4, pp.926-933, July/Aug. 2007.
- [10] S. Deng and A.P. Morrison, "Active quench and reset integrated circuit with novel hold-off time control logic for Geiger-mode avalanche photodiodes," *Opt. Lett.*, vol. 37, no. 18 pp. 3876 - 3878, 2012.
- [11] J.C. Jackson, D. Phelan, A.P. Morrison, R.M. Redfern, A. Mathewson, "Toward integrated single-photon-counting microarrays," *Optical Engineering*, vol. 42, no. 1, pp. 112 - 118, Jan. 2003.
- [12] J.C. Jackson, J. Donnelly, B. O'Neill, A.M. Kelleher, G. Healy, A.P. Morrison, A. Mathewson, "Integrated bulk/SOI GM-APD sensor: bulk substrate inspection with Geiger-mode avalanche photodiodes," *IET Electron Lett.*, vol. 39, no. 9, pp. 735 - 736, May. 2003.
- [13] http://www.first-sensor.com/cms/upload/datasheets/AD230-12_TO_501162.pdf.