

Using Spiral Dynamic Algorithm for Maximizing Power Production of Wind Farm

Mok Ren Hao, Raja Mohd Taufika Raja Ismail, Mohd Ashraf Ahmad

Instrumentation and Control Engineering Research Cluster, Faculty of Electrical and Electronics Engineering

Universiti Malaysia Pahang

26600, Pekan, Pahang, Malaysia

Tel: +6094246041, Fax: +6094246000 and E-mail: mashraf@ump.edu.my

Abstract

This paper presents a preliminary study of a model-free approach based on spiral dynamic algorithm (SDA) for maximizing wind farms power production. The SDA based approach is utilized to find the optimal control parameter of each turbine to maximize the total power production of a wind farm. For simplicity, a single row wind farm model with turbulence interaction between turbines is used to validate the proposed approach. Simulation results demonstrate that the SDA based method produces higher total power production compared to the particle swarm optimization (PSO) and game theoretic (GT) based approaches.

Keywords: spiral dynamic, model-free, wind farm optimization, power production, renewable energy

Introduction

Recently, existing wind turbine has a capability of adjusting its control variables, such as blade angle, yaw angle and generator torque, to maximize the power production. In the context of wind farm, the adjustment of those control variables not only affecting its own power production, but also can influence the power productions of the downstream turbines due to turbulence interactions among turbines. Moreover, the complexity of this turbulence interactions, which is difficult to model, make the problem of finding the optimal control variables is more challenging. Therefore, the study on improving the control algorithm of existing wind farms is interesting and it has attracted many control experts.

Realizing that the turbulence interactions amongst turbines are complex and difficult to model, a model-free control approach has become an effective solution to maximize the power production of existing wind farms. So far, there exists various model-free control approaches to improve the energy production of wind farms. These includes game theoretic (GT) and cooperative control based [1]–[3], maximum power point tracking [4], [5], simultaneous perturbation stochastic approximation [6], multi-resolution simultaneous perturbation stochastic approximation [7], Bayesian ascent [8] and random search [9] based approaches.

On the other hand, it is known that the spiral dynamic algorithm (SDA) [10] is a promising tool for maximizing power production of wind farm. It is because this algorithm is known to be effective for a variety of optimization problems, such as controller tuning [11], [12], system identification [13], and emission dispatch problems [14]. Moreover, the SDA

algorithm, which makes use of the feature of logarithmic spirals, is well known for its simple and effective strategy, while retains the diversification and intensification at the early and later phases of the trajectory.

This paper investigates the effectiveness of a spiral dynamic algorithm (SDA) as a model-free method and it is validated to a single row wind farm model. Then, the statistical analysis of the wind farm total power production is presented. Finally, a performance comparison between the SDA, particle swarm optimization (PSO) and the game theoretic (GT) [2] based approaches is shown. Since the SDA based method is in the class of population-based method, a suitable combination of the population size and maximum number of iterations is also investigated.

The organization of this paper is described as follows. Section II explains the problem formulation. In Section III, the step-by-step procedure of the SDA based methods is discussed. The SDA based approach is validated to the single row wind farm model in Section IV. The comparative study between the SDA, PSO and the GT based methods are also discussed in the same section. Finally, Section V provides some concluding remarks.

Problem Formulation

We consider N wind turbines in a wind farm, where the position of each turbine can be located randomly. The control variable of turbine j is defined as $q_j (j = 1, 2, \dots, N)$, which is a general form of the turbine controllers, such as pitch angle of the blade and speed of turbine rotor [15]. The power production of turbine j is denoted as $L_j(q_1, q_2, \dots, q_N) (j = 1, 2, \dots, N)$. The incoming wind speed with a time-varying speed and random direction is considered in this study. Therefore, we can say that the control variables except for turbine j , which are $q_1, q_2, \dots, q_{j-1}, q_{j+1}, \dots, q_N$, would also affect the turbine j power production L_j because of the turbulence interaction between turbines. Similarly, any variations of control variable q_j not only affect L_j but also $L_1, L_2, \dots, L_{j-1}, L_{j+1}, \dots, L_N$. Therefore, the total power production of turbine j highly depends on q_j and weakly depends on other control variables $q_1, q_2, \dots, q_{j-1}, q_{j+1}, \dots, q_N$. Since the turbine dynamics and the turbulence interactions amongst turbines are very complex, it is difficult to obtain an accurate model of the wind farm, which accurately provides the relation between L_j and q_1, q_2, \dots, q_N .

However, we assume that the total power production of the wind farm is measurable and can be represented as:

$$\bar{L}(q_1, q_2, \dots, q_N) = \sum_{j=1}^N L_j(q_1, q_2, \dots, q_N) \quad (1)$$

Then, we describe the problem as:

Problem 2.1. Let the wind farm total power production $\bar{L}(q_1, q_2, \dots, q_N)$ is given in (1) and functions $L_j(j = 1, 2, \dots, N)$ are unknown. Then, find control variables $q_j(j = 1, 2, \dots, N)$ such that $\bar{L}(q_1, q_2, \dots, q_N)$ is maximized.

Model-Free Design Using Spiral Dynamic Algorithm

This sections provides the main idea to solve Problem 2.1. Firstly, the SDA algorithm introduced by [10] is briefly explained. Next, model-free synthesize is shown by the control variables based on the SDA method.

A. Spiral Dynamic Algorithm

Let $f: \mathbf{R}^n \rightarrow \mathbf{R}$ be the objective function and $\theta_i \in \mathbf{R}^n (i = 1, 2, \dots, m)$ is the design variable for m number of agents. Then, a standard optimization problem is expressed by

$$\max_{\theta_1, \theta_2, \dots, \theta_m} f(\theta_i) \quad (2)$$

for $i = 1, 2, \dots, m$. The Spiral dynamic algorithm algorithm updates $\theta_i (i = 1, 2, \dots, m)$ iteratively by performing an updated equation as follow

$$\theta_i(t+1) = S_n(r, \alpha)\theta_i(t) - (S_n(r, \alpha) - I_n)\theta^*, \quad (3)$$

$i = 1, 2, \dots, m$, for $t = 0, 1, \dots$. In (3), I_n is n by n identity matrix, $r \in [0, 1]$ is a convergence rate of distance between a current position and the origin at each t , $\alpha \in [0, 2\pi]$ is a rotation angle around the origin at each t , θ^* is the best solution among all agents during a search, and $S_n(r, \alpha)$ is given by

$$S_n(r, \alpha) = r \prod_{l=1}^{n-1} \left(\prod_{w=1}^l R_{n-l, n+1-w}^{(n)}(\alpha_{n-l, n+1-w}) \right), \quad (4)$$

where $R_{l,w}^{(n)}(\alpha_{l,w})$ is a rotation matrix. Please see [10] for the details of $R_{l,w}^{(n)}(\alpha_{l,w})$. Then, the step-by-step procedure of the SDA algorithm is given by:

Step 1: Select the number of agents m , the rotation angle α , and the convergence rate of distance r . Set $t = 0$.

Step 2: Set the initial design variables $\theta_i(0) \in \mathbf{R}^n$, $i = 1, 2, \dots, m$ randomly in a pre-specified region. Then, find

$\theta^* = \theta_{i_c}(0)$, where $i_c = \arg \max_i f(\theta_i(0))$, $i = 1, 2, \dots, m$.

Step 3: Compute the updated equation in (3).

Step 4: Find $\theta^* = \theta_{i_c}(t+1)$, where $i_c = \arg \max_i f(\theta_i(t+1))$, $i = 1, 2, \dots, m$.

Step 5: Set $t = t+1$ and continue Step 3 if a pre-specified stopping criterion is not fulfilled. Otherwise, the algorithm stops with the optimal design variable θ^* .

In Step 5 of the algorithm, the stopping criterion is chosen from the maximum iterations, where the algorithm stops after a pre-determined number of iterations t_{\max} .

B. Model-Free Design

Using the SDA algorithm in Section III-A, the model-free SDA based method for maximizing wind farm power production is explained:

Step I: Select the maximum iterations number t_{\max} .

Step II: Perform the SDA algorithm in Section III-A by setting $L = f$ and q as θ .

Step III: After t_{\max} iterations, the algorithm stops with the optimal solution $q^* := \theta^*$ and the total power production \bar{L} is recorded.

Simulation Results

This section demonstrates the SDA based method for maximizing wind farm power production. A wind farm model, which replicates a real commercial wind farm, is considered to evaluate the proposed method. Firstly, the model of the wind farm proposed by [15] is described. Next, the SDA based approach is validated to the single row wind farm model.

A. Numerical Model of Wind Farm

Let N wind turbines in the wind farm is represented by the set $\mathcal{X} = 1, 2, \dots, n$, the incoming wind speed is denoted by V_ω , the turbine rotor diameter is defined by D_j , the rotor swept area of turbine k is represented by A_k . The symbol ϕ is a roughness parameter that describes the gradient of turbulence propagation $A_{j \rightarrow k}^{\text{ov}}$ is defined as the overlap region between the upstream turbine j turbulence and turbine k rotor swept region. The expression (z, r_ω) is defined as a point in the turbulence of the turbine, where z is the distance to the turbine rotor disk plane and r_ω is the distance to the center of the turbine rotor axis. Then, the aggregate wind speed is represented as:

$$\bar{V}_k = V_\omega \left(1 - 2 \sqrt{\sum_{j \in \mathcal{X}: z_j < z_k} \left(q_j \left(\frac{D_j}{D_j + 2\phi(z_k - z_j)} \right)^2 \frac{A_{j \rightarrow k}^{\text{ov}}}{A_k} \right)^2} \right) \quad (5)$$

where z_j is the distance to the turbine j rotor disk plane, while z_k is the distance to the turbine k rotor disk plane. Figure 1 shows the illustration of turbulence interaction between the two turbines. For $k \in \chi$, the wind speed \bar{V}_k is calculated using the wind speed aggregation deficit produced by each upstream turbine. It is assumed that the turbulence expands proportionally to the distance z and its diameter has a circular cross-section. Moreover, the power of each turbine is given by:

$$L_k = 2\rho A_k q_k (1 - q_k)^2 \bar{V}_k^3 \quad (6)$$

where ρ is the density of air.

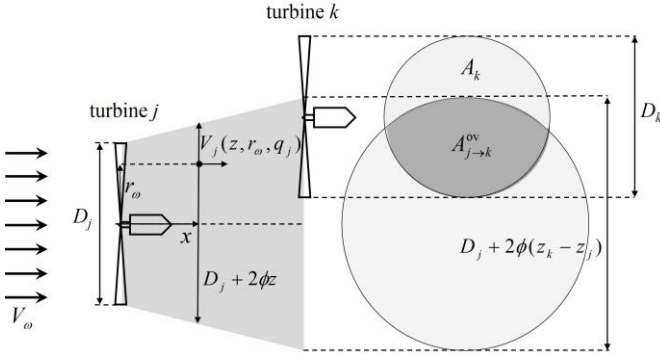

Fig.1 The illustration of turbulence expansion.

B. Single Row Wind Farm Example

This section demonstrates the performances of the SDA based method based on a simple ten-turbine row wind farm as shown in Figure 2. We use the model in Section IV-A for this single row wind farm. The wind farm consists of 10 turbines with 80 m diameter. The distance between each turbine is equal to seven turbine diameters, i.e., 560 m. The values of air density and the roughness parameter are $\rho = 1.225 \text{ kg/m}^3$ and $\phi = 0.04$, respectively. In this preliminary study, the performance of the SDA, is compared with the standard PSO algorithm in [16] and the game theoretic approach in [2] for the specific wind direction only. In particular, we select the case when wind direction is perpendicular to the rotational motion of turbine's blade since a much larger turbulence effect is generated amongst turbines.

Firstly, it is assumed that the incoming wind speed is constant at $V_\omega = 8 \text{ m/s}$. Next, the parameters of SDA based method is set as $r = 0.97$ and $\alpha = \pi/4$, after several preliminary experiments are performed. The parameters of PSO based method [16] is set as $c_0 = 0.9$, $c_1 = 0.1$, and $c_2 = 0.5$. Meanwhile, the game theoretic method with random step interval size $K_G = 0.03$ and the probability of update the design variable $E = 0.3$ are considered. Please see [2], [16] for the details of GT and PSO algorithms. The initial control variable of each turbine, which is given by $\theta_i(0) = 1/3$. In order to see the effect of random parameters in all methods, 100 independent trials are executed for the SDA, PSO and GT based methods.

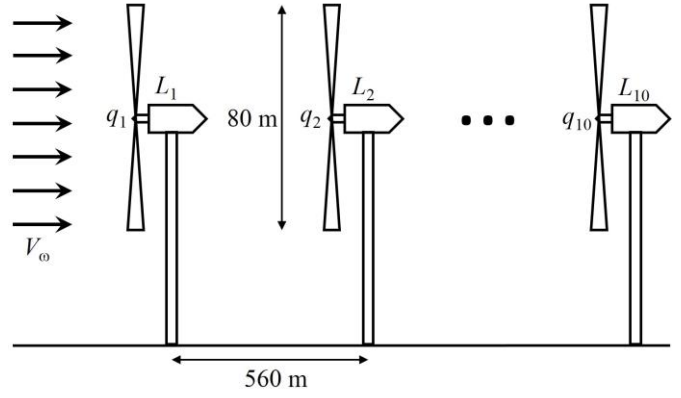

Fig. 2 Single row wind farm layout.

In this study, we set the number of evaluations is set as 10000 for all methods in order to obtain a fair comparative study. In this sense, we set $k_{\max} = 10000$ for GT based method, since it only requires one evaluation per iteration. Meanwhile, for SDA and PSO, we perform several preliminary study to find a suitable combination of the k_{\max} and the m . Here, the optimal combination of k_{\max} and m is selected for each method such that the mean, best, and worst of total power production are maximum and its standard deviation is minimum. Based on the analysis, $k_{\max} = 200$ and $m = 50$ are chosen for both SDA and PSO based methods. Table I shows the statistical analysis of the total power production after 10000 number of evaluations. Notice that the SDA based approach produces higher best total power production (4.7648415723 MW) compared to PSO (4.7648414855 MW) and GT (4.7627457259 MW) based methods. We also can observe a similar pattern for the values of mean and worst of the total power production. Moreover, the SDA based approach yields slightly lower standard deviation value compared to PSO and GT based approaches. This result proves that the SDA based method is robust to the randomization effect and can achieve maximum total power production with high probability. In terms of the obtained optimal control variables, the best optimal control variables of the SDA based approach are obtained as turbine $\{1; 2; 3; 4; 5; 6; 7; 8; 9; 10\} = \{0.2061; 0.1611; 0.1648; 0.1651; 0.1698; 0.1173; 0.2258; 0.1877; 0.1837; 0.3333\}$. It can be seen that the optimal control variable value of the first turbine is higher than the intermediate turbines, while the value in the final turbine is remained as the initial control variable. This pattern is similar to recent investigation on wind farm control, e.g., [2], while producing better total power production.

Conclusion

In this paper, a preliminary study of a model-free method based on spiral dynamic algorithm (SDA) for wind farm control has been investigated. The proposed method is simulated on a single row wind farm layout. In the numerical example, the SDA based approach produces a better total power production than PSO and GT based methods with more consistent results. In this sense, it shows the potential of SDA based method for model-free approach of wind farm control.

TABLE I
PERFORMANCES COMPARISON OF THE TOTAL POWER PRODUCTION (MW) OF THE SDA, PSO AND GT BASED
METHODS

Statistical analysis	SDA	PSO	GT [2]
Mean (MW)	4.7648415723	4.7648415625	4.7644075485
Best (MW)	4.7648415723	4.7648415723	4.7648415242
Worst (MW)	4.7648415723	4.7648414855	4.7627457259
Standard deviation	1.1039824×10⁻⁷	0.0141665007	4.513106×10 ²

Acknowledgement

The work was partly supported by Research Grant RDU160374 from the Research and Innovation Department, University of Malaysia Pahang.

References

- [1] J.R. Marden, S.D. Ruben, and L.Y. Pao, "Surveying game theoretic approaches for wind farm optimization," in *Proc. of the AIAA Aerospace Sciences Meeting*, 2012, pp. 1-10.
- [2] J.R. Marden, S.D. Ruben, and L.Y. Pao, "A model-free approach to wind farm control using game theoretic methods," *IEEE Transactions on Control Systems Technology*, vol. 21, no. 4, 2013, pp. 1207-1214.
- [3] J. Park, S. Kwon, and K.H. Law, "Wind farm power maximization based on a cooperative static game approach," in *Proc. SPIE 8688, Active and Passive Smart Structures and Integrated Systems*, 2013.
- [4] P.M. Gebraad, F.C. van Dam, and J.W. van Wingerden, "A model-free distributed approach for wind plant control," in *Proc. American Control Conference*, 2013, pp. 628-633.
- [5] P.M. Gebraad, and J.W. van Wingerden, "Maximum power-point tracking control for wind farms," *Wind Energy*, vol. 18, no. 3, 2015, pp. 429-47.
- [6] M.A. Ahmad, S.I. Azuma, and T. Sugie, "A model-free approach to wind farm control using simultaneous perturbation stochastic approximation," in *Proc. of 21st International Symposium on Mathematical Theory of Networks and Systems*, 2014, pp. 1352-1355.
- [7] M.A. Ahmad, S.I. Azuma, and T. Sugie, "A model-free approach for maximizing power production of wind farm using multi-resolution simultaneous perturbation stochastic approximation," *Energies*, vol. 7, no. 9, 2014, pp. 5624-5646.
- [8] J. Park and K.H. Law, "A data-driven, cooperative wind farm control to maximize the total power production," *Applied Energy*, vol. 165, 2016, pp. 151-165.
- [9] M.A. Ahmad, M. Ren Hao, R.M.T. Raja Ismail, and A.N.K. Nasir, "Model-free wind farm control based on random search," *Proceedings of IEEE International Conference on Automatic Control and Intelligent Systems*, 2016.
- [10] K. Tamura, and K. Yasuda, "Primary study of spiral dynamics inspired optimization," *IEEJ Transactions on Electrical and Electronic Engineering*, 6(S1), 2011, pp. S98-S100.
- [11] A.N.K. Nasir, M.O. Tokhi, N. Abdul Ghani, and M.A. Ahmad, "A novel hybrid spiral-dynamics bacterial-foraging algorithm for global optimization with application to control design", in *12th UK Workshop on Computational Intelligence (UKCI)*, 2012, pp. 1-7.
- [12] A.N.K. Nasir, M.O. Tokhi, N.A. Ghani, and M.A. Ahmad, "A novel hybrid spiral dynamics bacterial chemotaxis algorithm for global optimization with application to controller design", in *International Conference on Control (UKACC)*, 2012, pp. 753-758.
- [13] A.N.K. Nasir and M.O. Tokhi, "A novel hybrid bacteria-chemotaxis spiral-dynamic algorithm with application to modelling of flexible systems", *Engineering Applications of Artificial Intelligence*, 33, 2014, pp. 31-46.
- [14] L. Benasla, A. Belmadani, and M. Rahli, "Spiral optimization algorithm for solving combined economic and emission dispatch", *International Journal of Electrical Power and Energy Systems*, 62, 2014, pp. 163-174.
- [15] A.K. Scholbrock, "Optimizing wind farm control strategies to minimize wake loss effects", University of Colorado At Boulder, 2011.
- [16] J. Kennedy and R. C. Eberhart, "Particle swarm optimization", in *Proc. IEEE Int. Conference on Neural Networks*, Perth, Australia, 1995, pp. 1942-1948.