

Development of Wireless Passive Water Quality Catchment Monitoring System

Muhammad Aznil Ab Aziz, M. F. Abas, A. A. N. Faudzi, N. Md. Saad, A Irawan
Faculty of Electrical and Electronics Engineering, Universiti Malaysia Pahang, 26600 Pekan, Pahang
mfadhil@ump.edu.my

Abstract—To maintain the quality of aquatic ecosystems, good water quality is needed. The quality of water needs to be tracked in real-time for environmental protection and tracking pollution sources. This paper aims to describe the development and data acquired for water catchment quality monitoring by using a passive system which includes location tagging. Wireless Passive Water Quality Catchment Monitoring (WPWQCM) System is used to check and monitor water quality continuously. The condition of water in terms of acidity, temperature and light intensity needs to be monitored. WPWQCM System featured four sensors which are a temperature sensor, light intensity sensor, pH sensor and GPS tracker that will float in water to collect the data. GPS tracker on passive water catchment monitoring system is a new feature in the system where the location of water can be identified. With the extra feature, water quality can be mapped and in the future, the source of disturbance can be determined. UMP Lake was chosen to check and monitor the water quality. The system used wireless communication by using XBee Pro as a medium of communication between CT-Uno board and PC.

Index Terms—GPS tracker; Low-Cost System; Water Catchment Monitoring; Water Mapping; Water Quality.

I. INTRODUCTION

Water quality is one of the topics which always be researched on. Water is the basic component of human and other living beings and having good quality water is a must. In obtaining the quality of water, several developments have been made to access the quality of water catchment.

Monitoring river catchment using PALSAR satellite has been done by Tasneem Ahmad et. al. in [1]. PALSAR satellite data is used to monitor river catchment by discriminating the change areas between two different dates images. Image differencing and image ratioing have been utilized to characterize the transient changes. Similar to Tasneem Ahmad, M. Rizaludin Mahmud et. al., in their paper [2] has also utilized satellite data for catchment monitoring. Iris Heine et. al., in their paper [3] also uses satellite data. The satellite data was acquired from TerraSAR-X. The paper tests the potential of multi-temporal high-resolution TerraSAR-X data for water surface detection and monitoring seasonal changes in a large, semiarid catchment with poor data availability.

Other development of water catchment monitoring that does not involve obtaining satellite data can be seen in [4][5][6]. Aravinda S. Rao et. al., in [4], presented an affordable wireless aquatic monitoring system. The system is capable of temperature, pH, conductivity, dissolved oxygen and oxidation-reduction potential. The system shows a promising result with good accuracy. For a larger network of sensors, Siddeswara et. al., in [5], uses rainfall, river level and

river flow sensors which are connected to the grid. The system also integrates workflow composer, decision support systems and continuous flow forecasting model. The hydrological sensor web has successfully been deployed and shows promising result. Other than that, B O'Flynn et. al., in their paper [6] has also developed a multi-sensor system which uses wireless sensor network platform for water quality monitoring. The system is able to detect phosphate, temperature, depth, pH and conductivity of the monitored water.

Water catchment monitoring using satellite data as discussed in [1][2][3] is precise and reliable. Unfortunately, to access the data require a high financial cost. Because of this, numerous development on low-cost catchment monitoring has been initiated and some has produced a promising result which can be seen in [4][5][6]. The system developed in [4][5][6] does not integrate GPS data, similar to [1][2][3].

This paper discussed the initial development of wireless passive water quality catchment system in FKKEE, UMP, Malaysia which integrates GPS, pH, Light and temperature readings. The system has been tested at a lake in UMP Pekan Campus, Pahang, Malaysia and shows a promising result.

II. METHODOLOGY

Wireless Passive Water Quality Catchment Monitoring (WPWQCM) System was tested to collect the data of water. The water condition based on acidity, temperature and light intensity has been determined and every location that has been tested is located based on GPS reading that includes in the system. Four sensors have been used in the system and are listed in Table 1.

Table 1
Sensors

No	Type	Model	Usage
1	Analog Light	GA1A12S202	Measuring Turbidity
2	Analog pH	SEN0161	Measuring pH
3	Waterproof Temperature	DS18B20	Measuring Temperature
4	GPS	LOCOSYS LS-23060	Coordinate Acquisition

Analog light and LED is submerged into the water with a separation distance of 10cm. This will enable the system to measure water turbidity. CT-UNO board has been used as a microcontroller for the system. Xbee-Pro has been chosen as a medium of communication between microcontroller and PC wirelessly. Figure 1 shows the hardware connection diagram of the whole system.

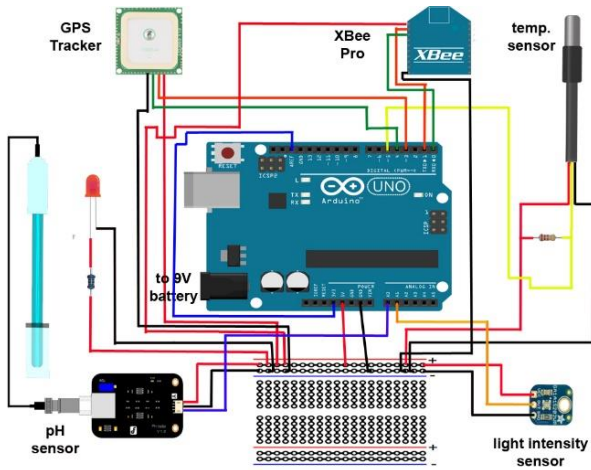

Figure 1: Hardware connection diagram

The overall measuring process starts with acquiring GPS coordinates, temperature, light intensity and pH. The overall process will wait until all data is acquired before the data is sent to the base station wirelessly. The flow chart can be seen in Figure 2.

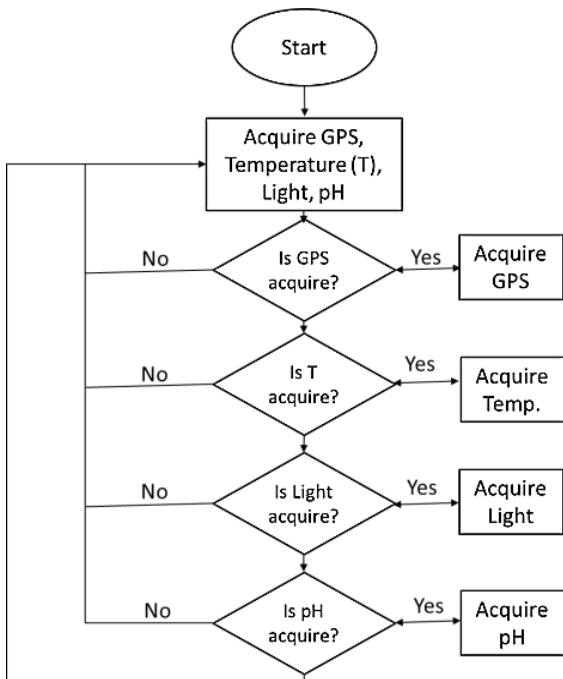

Figure 2: Flowchart of WPWQCM System

To protect the hardware from water, 3D printed casing is fabricated. The material used for printing is polylactide (PLA). All the sensors, boards and batteries are inserted in the casing once it is completely fabricated. Figure 3 and Figure 4 shows the 3D design by using SketchUp of the whole casing and internal section respectively. Figure 5 shows the fully printed casing whereas Figure 6 shows the fully packed sensors in the casing.

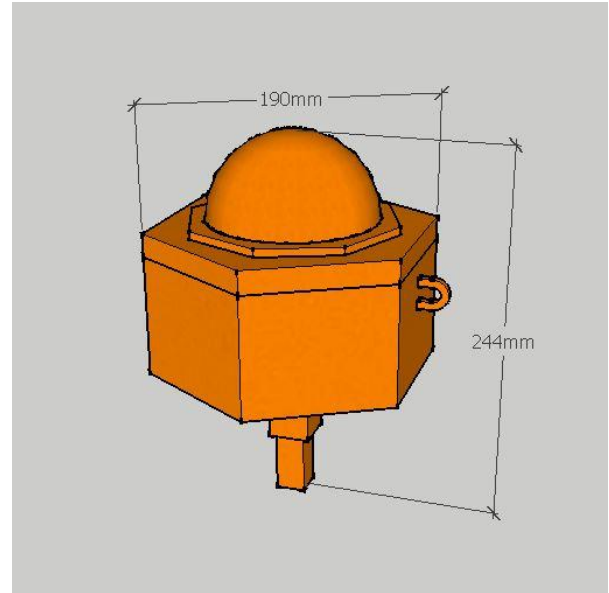

Figure 3: 3D Casing Dimension

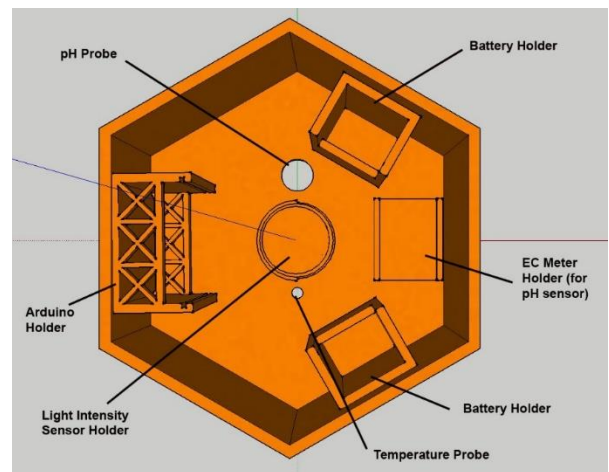

Figure 4: Casing and sensor location.

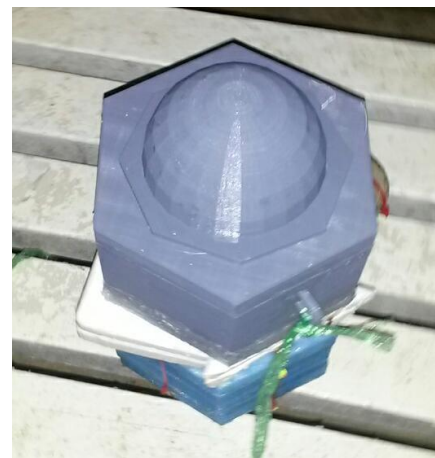

Figure 5: Fabricated Casing



Figure 6: Packed WPWQCM

The study area is chosen to be Universiti Malaysia Pahang UMP's lake located at East Malaysia in the state of Pahang. 14 locations have been chosen and tested around the UMP's lake to compare the data for every location. The circumference of the lake is about 1.6 kilometers is big enough to set a testing area. Figure 7 shows testing being carried out. The WPWQCM System provides us with the following functionalities:

- Temperature of catchment is measured.
- Light intensity of catchment is obtained.
- pH value of catchment has been identified.
- The system has successfully identified the coordinate of the testing area.



Figure 7: Testing

III. RESULT AND DISCUSSION

Primary testing on the lake has been executed and the results have been obtained. For each location, the average value of GPS, temperature, light intensity and pH is taken and plotted.

A. GPS Coordinate for 14 Locations

Figure 8 shows the GPS value for every 14 locations. Based on the value of GPS obtained, the range is within 2 meter from the actual location. GPS Locosys LS-23060 has a range +/- 2 meter from the actual location. It can be concluded that the value is within the range.

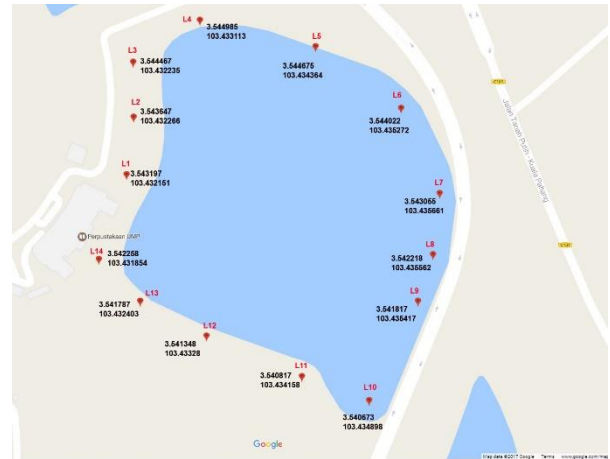

Figure 8: GPS coordinate at 14 locations

B. pH Value for 14 Locations

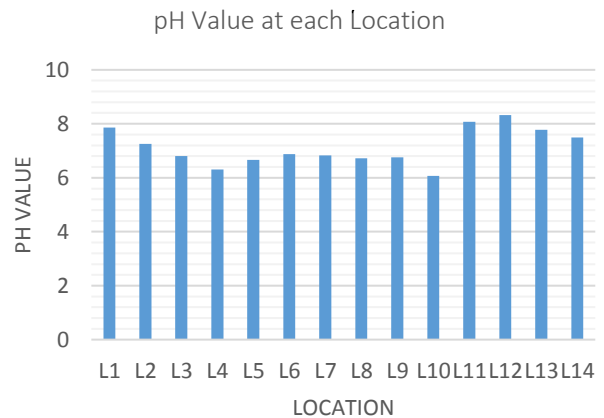

Figure 9: Graph of pH against location

The average value of pH for every 14 locations has been plotted in Figure 9. The value of pH is different for every location. The highest pH value has been obtained at Location 12 with a value of 8.32, while the lowest value is 6.07 at Location 10. The average pH of 14 locations is 6.64 and standard deviation, $\sigma = 0.816$.

C. Light Intensity Value for 14 Locations

The average value of light intensity has been seen in Figure 10. The highest value has been obtained at Location 12 with a value of 862.964 lux while the lowest value detected at Location 10 with value 123.631 lux. The average value of light intensity for 14 locations is 374.146 lux with standard deviation, $\sigma = 203.351$.

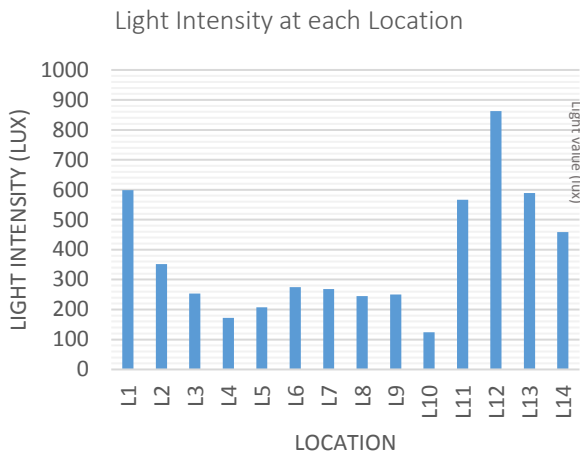

Figure 10: Graph of light intensity (lux) against location

D. Temperature Value for 14 Locations

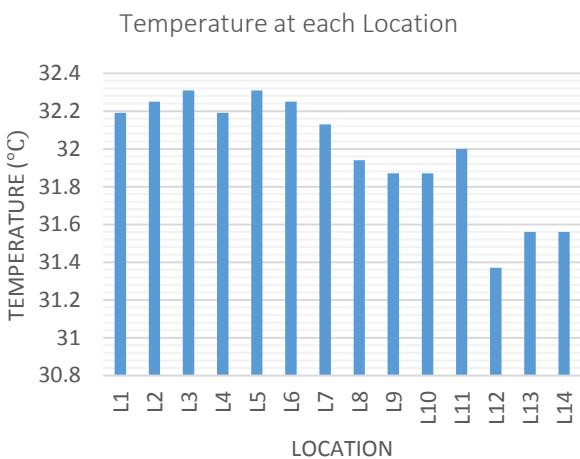

Figure 11: Graph of Temperature (°C) for each location

The average value of temperature for every location has been figured out in Figure 11. The values of temperature are different for every location. The highest value has been obtained both at Location 3 & 5 with a value of 32.31°C, while the lowest value has been obtained at Location 12 with a value of 31.37°C. The average temperature for 14 locations is 31.99°C with standard deviation, $\sigma = 0.296$.

IV. CONCLUSION

The development of the WPWQCM system has successfully collected data continuously in terms of acidity, light intensity, temperature and location. The collected data have small standard deviation between locations. The deviation of the data could be used to build acidity, light intensity and temperature map. This could potentially be used to predict the source of the disturbance. The WPWQCM System has successfully been developed but there is room for improvement.

ACKNOWLEDGMENT

The authors would like to thank UMP for financing the research through final year student project fund and PnI research fund.

REFERENCES

- [1] Tasneem Ahmed, Akanksha Garg, Dharmendra Singh, Balasubramanian Raman, 2014, An Approach to Monitor River Catchment with PALSAR Satellite Data, *9th IEEE International Conference on Industrial and Information Systems (ICIIS2014)*, Bihari Vajpayee Indian Institute of Information Technology and Management Gwalior, India
- [2] M. Rizaludin Mahmud, Mazlan Hashim, 2011, Operational Satellite-based Watershed Monitoring Systems (SAWMOS) for Large Humid Tropical Catchment Environment, *IEEE Colloquium on Humanities, Science and Engineering Research (CHUSER 2011)*, Dec 5-6 2011, Penang.
- [3] Iris Heine, Till Francke, Christian Rogass, Pedro H. A. Medeiros, Axel Bronstert and Saskia Foerster, 2014, Monitoring Seasonal Changes in the Water Surface Areas of Reservoirs Using TerraSAR-X Time Series Data in Semiarid Northeastern Brazil, *IEEE Journal of Selected Topics in Applied Earth Observations and Remote Sensing*, Vol 7, No.8, August 2014.
- [4] Aravinda S. Rao, Stephen Marshall, Jayavardhana Gubbi, Marimuthu Palaniswami, Richard Sinnot, and Vincent Pettigrove, 2013, Design of Low-cost Autonomous Water Quality Monitoring System, *IEEE International Conference on Advances in Computing, Communications and Informatics (ICACCI)*, 22-25 Aug 2013, Mysore, India.
- [5] Siddeswara Mayura Guru, Peter Taylor, Holger Neuhaus, Yanfeng Shu, Daniel Smith and Andrew Terhorst, 008, Hydrological Sensor Web for the South Esk Catchment in the Tasmanian state of Australia, *4th IEEE International Conference on eScience*, pg(s): 432-433.
- [6] B O'Flynn, Rafael Martinex Catala, S. Harte, C. O'Mathuna, John Cleary, C. Slater, F. Regan. D. Diamond and Heather Murphy, 2007, SmartCoast: A wireless Sensor Network for Water Quality Monitoring, *32nd IEEE Conference on Local Computer Networks*, pg(s): 815-816.
- [7] Iswandi, Herlina Tri Nastiti, Ina Eprilia Praditya, I Wayan Mustika, "Evaluation of XBee- Pro Transmission Range for Wireless Sensor Network's Node under Forested Environments Based on Received Signal Strength Indicator (RSSI)," *2nd International Conference on Science and Technology-Computer*, 2016.
- [8] Sun Xiaoyong, Cao liangcheng, Ma Honglin, Gao Peng, Bai Zhanwei, Li Cheng, "Experimental Analysis of High Temperature PEEK Materials on 3D Printing Test," *9th International Conference on Measuring Technology and Mechatronics Automation*, pp.13-16, 2017.