

FEASIBILITY STUDIES ON UTILIZATION OF LOW PRESSURE IN HYDRO-PNEUMATIC DRIVELINE

F. Wasbari^{1*}, R. A. Bakar², L. M. Gan³, M. A. Salim⁴

^{1,2,3}Faculty of Mechanical Engineering, Universiti Malaysia Pahang,
26600 Pekan, Pahang, Malaysia.

^{1,4}Faculty of Mechanical Engineering, Universiti Teknikal Malaysia Melaka,
Hang Tuah Jaya, 76100 Durian Tunggal, Melaka, Malaysia.

ABSTRACT

The aim of this paper is to present a feasibility study on the use of low pressure in vehicle's small applications. Hydro-pneumatic driveline is one of the hybrid sub-systems for hydraulic hybrid vehicle. Usually, the energy supplied by hydro-pneumatic accumulator/storage operates through maximum energy level to a minimum. This often reaches to the point where the limit of minimal operations is higher than the pre-charge limit. The remaining power is claimed as not effective to move a vehicle, but the pressure still contains energy. Therefore, it is a waste of energy. The pressure energy can be used to power vehicle's small applications such as fan, starting motor, compressor, hybrid electric battery charger, and others. Hence, a laboratory-scale experiment was extended away to see the hydro-pneumatic drive system behavior to operate at low-pressure level. Through the experiment, it was found that the system can work at low-pressure level. However, the power generated was 740 watt, 16.2 Nm theoretical torque and operated at 52 % efficiency at a pressure of 50 bar. This value is too small if compared to the force needed to move the vehicle. Still, it was dependable enough to power the small application in the vehicle sub-system. Through this research, it is hoped that the ineffective pressure of the hydraulic hybrid vehicle can be utilized so it can contribute to the increase of efficiency.

KEYWORDS: *Hydro-pneumatic storage; accumulator; hydraulic hybrid vehicle*

1.0 INTRODUCTION

Hybrid technology has become popular in the automotive industry since the technology is proven to improve vehicle efficiency, save fuel consumption and promote green technology (Huang & Tzeng, 2005). The hydraulic hybrid car is a combination of two or more types of propulsion sub-systems working in a car. This concept is not a new design because it has been practised to heavy vehicle as a part of its hybrid system. Nevertheless, applying the idea of hydro-pneumatic on passenger car is an innovation (Ma, Schock, Carlson, Hoglund & Hedman, 2006; Zhang, Lv, Gou & Kong, 2012; Boretti & Zanforlin, 2014; Achten, Vael, Sokar & Kohmäscher, 2008). The hydraulic hybrid technology uses a combination of internal combustion engine (ICE) system as the main propulsion, hydro-pneumatic system as a hybrid propulsion unit and secondary propulsion. During operation, the energy is stored in the storage system called accumulator, and once the energy in the accumulator is low, through braking and

* Corresponding Email: faizil@utem.edu.my

coasting, the regenerative braking is activated to charge the accumulator, particularly. The concept utilizes energy losses in braking and recovers them into useful energy. The hydro-pneumatic driveline is normally applied by the heavy vehicle as secondary propulsion (Boretti & Stecki, 2012; Lin, Wang, Hu & Gong, 2010; Mrdja, Miljic, Popovic, Kitanovic & Petrovic, 2012). It is also widely practised in suspension system (Livermore, Annunzio & Ford, 2009). A hydro-pneumatic hybrid system is suitable for any vehicle because of its high-power density type. Tavares, Johri, Filipi (2011) and Nedelea (2013) claimed that the hydro-pneumatic hybrid saves fuel consumption and increases vehicle's efficiency (Tavares, Johri & Filipi, 2011; Nedelea, 2013). Therefore, this system is worth for money as well. Compared to the electric hybrid system, the hydro-pneumatic system is lighter. Based on PSA Peugeot-Citroen study, the company claimed that it can be cheaper (Gain, 2015). The system also requires lower maintenance, and the use of accumulator does not involve energy degrading like a hybrid electric battery. Many types of research have been conducted which are related to this technology and can be classified into four systems called ICE, hydro-pneumatic driveline, transmission system, and control system as illustrated in Figure 1 (Diego-ayala, 2007; Dimitrova, Lourdais & Mar, 2015; Tavares et al., 2011).

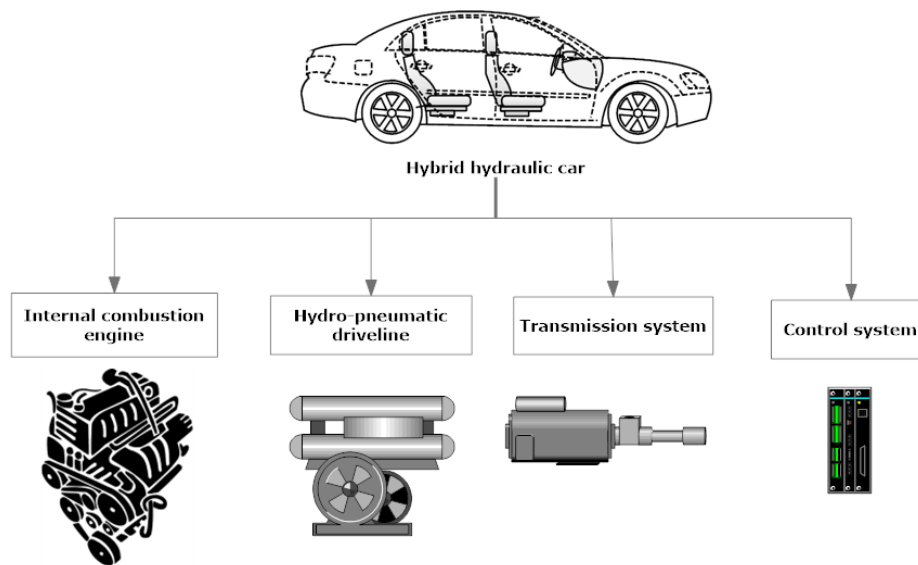

Figure 1. Sub-system of hydraulic hybrid car

One of the key parts for hydro-pneumatic driveline is a storage system. It consists of the accumulator, pressure valve and safety block. The more detail, the accumulator comprises a casing, bladder with 99.9% nitrogen, pressure valve, and safety stop. Bladder is made of an elastomer material to withstand high-pressure hydraulic oil. Nitrogen gas is used as a compression medium because it delivers a high heat absorption resistance to pressure changes. Air does not have endurance in such a way, and it can give greater explosion risk than nitrogen. The pressure gauge is used as an indicator of the level of pressure in the accumulator. Finally, the safety block which works as a pressure relief valve to protect the accumulator from the over-pressure. With the availability of this component, charging operation is safer and more dependable. Storage system carries out two main activities called charging and discharging process (Tavares, 2011). The charging process involves compression by hydraulic oil to nitrogen bladder. Along the compression process, temperature changes are imperative for review. However, in comparison to pneumatic compression, hydro-pneumatic compression produces lower temperature because

hydraulic oil is incompressible and acts as absorbers of heat generated by nitrogen compression. It can be said that the system is like being built-in with a heat exchanger (Boschrexroth, 2016).

Lammert et al. (2014) conducted a lab- scale experiment to parcel delivery truck. The truck used an 83.3 L accumulator that operated at 241 to 276 bar. Based on the research, it was found that the configuration was able to increase by 19 % to 52 % of fuel consumption in the diesel engine while 30 % to 56 % saving in the gasoline engine (Lammert et al., 2014). Pressure below 241 bar is not utilized for any usage because it is ineffective. Kepner (2002) had used the bladder gas accumulator 54.5 L, which operated at 172 to 345 bar at 5.4 L V8 sports utility vehicle. It was found that the arrangement was likewise able to cut the emission that affects pollution (Kepner, 2002). Boretti & Zanforlin (2014) took their first step to simulate the hybrid system in passenger car application. The high-pressure accumulator operated between 135 to 485 bars and the low-pressure tank 3.5 to 13.5 bars. The system was able to achieve 30 % better fuel economy (Boretti & Zanforlin, 2014). In all cases, it was found that the available pressure below the minimum level but above the pre-charge value was not utilized.

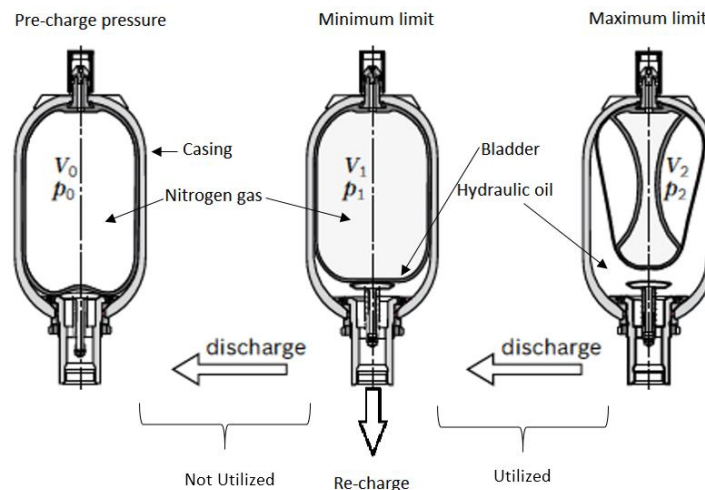

Figure 2. The relationship between utilized and not utilized energy (Boschrexroth, 2016)

Normally, the energy provided by hydro-pneumatic accumulator operates from maximum energy levels to a lower limit as illustrated in Figure 2. This often comes to where the limit of minimal operations is more eminent than the pre-charge limit. The remaining power is claimed as not effective to move a vehicle, but the pressure still contains energy. Therefore, it is a waste of energy. The pressure energy can be used to drive vehicle's small applications such as fans, motor starter, compressor, hybrid electric battery charger, wiper motor and so on which mostly operate at 12V voltage. Normally, the required power for vehicle's small applications is less than 2 horsepower. Most studies related to hydraulic hybrid contribute significantly to the research, but none of the studies are related specifically to the utilization of low-pressure parameter on the driveline.

Low pressure below minimum operating pressure still has some energy left. If this energy is not used, then technically, it causes losses. If losses are incurred in any of the systems so directly, it causes low efficiency. For example, systems that use all energy supplied without a loss is said to operate at 100 % efficiency. However, if there is 20 % of the

energy supplied not being used or lost due to certain limitation, then the system operates at 80 % efficiency. The effectiveness of such systems become less by 20 % than necessary. However, no system operates at 100 % efficiency because of the occurrence of loss such as thermal, fluid power and mechanical losses. Nevertheless, if all such losses can be reduced , then the system efficiency will be more beneficial. A simulation by using Automation Studio software running is shown in Figure 3. The parameter for charging process was set at 30 bar pre-charge pressure, and volume displacement is 50 cm³/rev. The purpose was to find out the effective volume capacity left under low pressure of 100 bar. This pressure was selected based on minimum pressure derived from the literature review. It was found that 10-liter capacity storage contains total effective 8 liters volume at 100 bar pressure. For a storage of 30 and 50 liters capacity, the total effective volume remaining in the storage is about 20 liters and 35 liters, respectively. This simulation has shown that in terms of pressure and effective volume, the low pressure is eligible to be utilized.

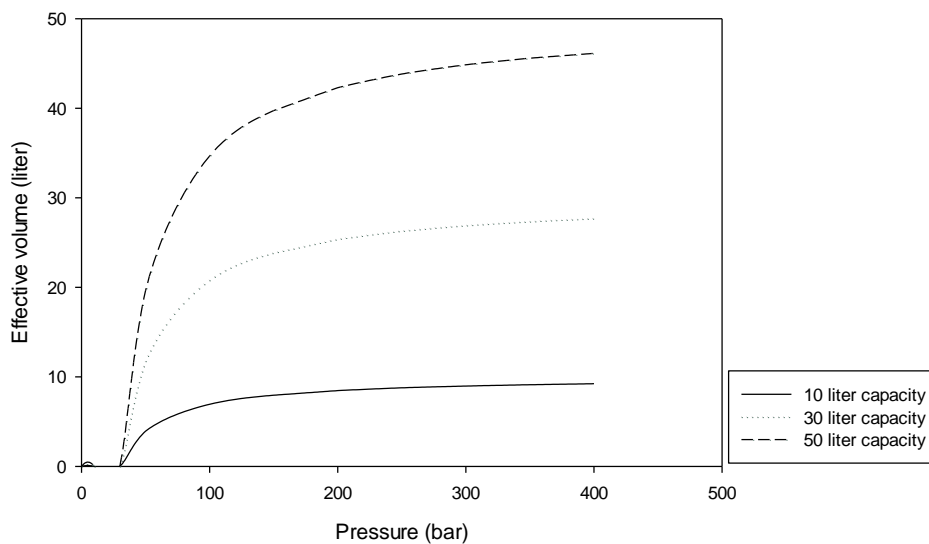

Figure 3. Simulation on effective volume at different liter capacity

2.0 RESEARCH METHODOLOGY

The study began by defining the problem with the assistance of literature review from previous studies. The procedure is necessary because it tells where the research is, what is the current progress and what are the problems faced. In fact, it helps to design new solutions. Then, the procedure of designing a schematic diagram was conducted , and in the end, the functional simulation was conducted by using Automation Studio software. If there is a problem with the simulation, then improvement or corrections can be worked on until the desired effects were received. The next operation was the experiment setup. Then, the process of installation and fabrication was started based on the schematic diagram. The experiment was designed to obtain the dependence data such as time, revolution per minutes, and the flow rate; while the strength per unit area is independently variable. The data was compared with the component specification to ensure that it was within the range and reasonable. Since the study was conducted by using an experimental approach, the next explanation will be based on the schematic diagram as shown in Figure 4.

In the initial condition, the pump supplies pressurized hydraulic oil to the accumulator. The pressure safety is embedded in the accumulator block. The experiment was conducted by using 0.75 L Hydac accumulator with a permissible pressure ratio of 8:1 which is 30 bar and maximum operating pressure is 210 bar. The flow rate specification for the accumulator is 95 L/min. The operating pressure was set from 30 bar to 50 bar. The pressure was selected based on the minimum range of permissible of the accumulator and the capability of the pump that is currently available. The Rexroth safety block was used to protect the accumulator from over pressure. The Sauer-Danfoss OMM8 rotary actuator was used as propulsion, but there was no load given to the output. The hydraulic motor has 8.2 cm³ displacement and a maximum speed of 2450 rpm. The Rexpower fix displacement vane pump was used to charge the accumulator with the volume displacement of 8 cm³/revolution. For the charging process, the gate valve 1 and 2 were opened while the rest were closed. When the pressure in the accumulator reached the set limit, the gate valve 1 and 2 were closed. Then, to operate the hydraulic motor, gate valve 2 and 3 were opened. The fluid flows were measured by using measuring glass.

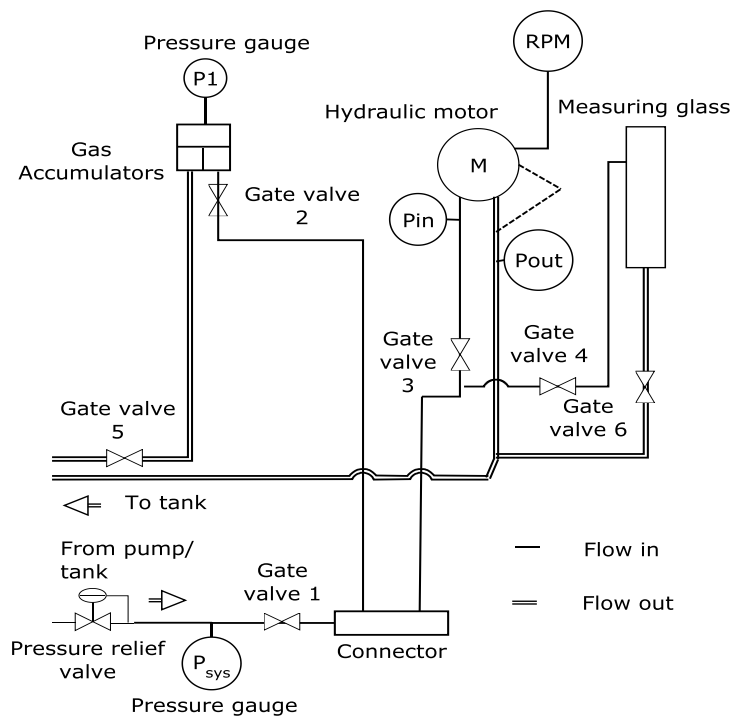

Figure 4. Schematic diagram

The experiment assumed that the flow rate at any point in the system was constant. Based on the layout, the input power can be calculated by using the following equation.

$$P_{fluid} = p_1 \times Q \tag{1}$$

where P_{fluid} is the power (watt) produced by the energy storage. It depends on p_1 pressure in (N/m²) and Q is the flow rate (m³/s) in the input area. In this study, it is assumed that the vane motor is working without losses. So, the shaft power is equal to fluid power. Therefore, the power produced by the motor is calculated by using the following equation.

$$P_{motor} = \frac{2\pi NT}{60} = \Delta p \times Q \quad (2)$$

where, P_{motor} is the power produced by motor (watt), N is the motor speed (rev/min), T is the theoretical torque (Nm), Δp is the pressure difference (N/m²) or equivalence to $p_{in} - p_{out}$ and Q is the flow rate (m³/s). By inserting equation 2 in equation 3, the theoretical torque can be simplified as

$$T = \frac{60P_{motor}}{2\pi N} \quad (3)$$

where, T is the theoretical torque (Nm), P_{motor} is the power produced by the motor (Watt) and N is the motor speed (rev/min). Another important parameter is the system efficiency which serves as how much energy is converted to useful work as shown in equation 4.

$$\eta_{overall} = \frac{P_{motor}}{P_{in}} \times 100 \quad (4)$$

where, $\eta_{overall}$ is the the overall efficiency of the system, P_{motor} is the power produced by a motor (watt) and P_{in} is the power (watt) produced by the energy storage.

3.0 RESULTS AND DISCUSSION

Based on the experiment data, the performance of the hydro-pneumatic can be presented as the effects of accumulator pressure on the fluid power parameters. Minor adjustments have been made where the pressure below the pre-charge value which is 30 bar has been ignored because no significant changes were recorded, and these values are insignificant. These are due to the influence of bulk modulus at the beginning process of the compression. The experiment parameters include the charging time, torque, power, speed, flow rate, and efficiency. Detailed analysis are as follow:

3.1 Pressure Elevation and Temperature

Figure 5 shows the effect of surrounding temperature to the compression process in the accumulator. The surrounding temperature sensor was placed at the base level of the workbench. It is midway between the pump that is used to charge the accumulator and accumulator storage. Based on the result, it is found that the power unit produces a change in surrounding temperature. The higher the system pressure is, the higher is the increase in surrounding temperature. However, the rising temperature does not affect the accumulator. In the beginning, there is no temperature change recorded between 30 to 35 bar. It is because the pressure value is low and almost equal to the pre-charge pressure. When the accumulator pressure is equivalent to the pre-charge pressure, then there is no increase in volume because the compression process has not occurred yet. In the pneumatic systems, compression process results in high-temperature changes, but in the

hydro-pneumatic system, the compression process seems to be in the isothermal state. The change takes place slowly enough to permit the arrangement to adjust continually to the temperature of the outside through heat exchange. Two things could explain the scenario. First, it is because of the existence of hydraulic fluid itself as compression medium. It is indirectly absorbing the temperature. Coupled with the accumulator thickness to stand high pressure, the slight increase in surrounding temperature is not directly affected by it. Secondly, the system pressure is low, and it is not capable of causing changes in the accumulator temperature. The accumulator temperature remains at 30°C.

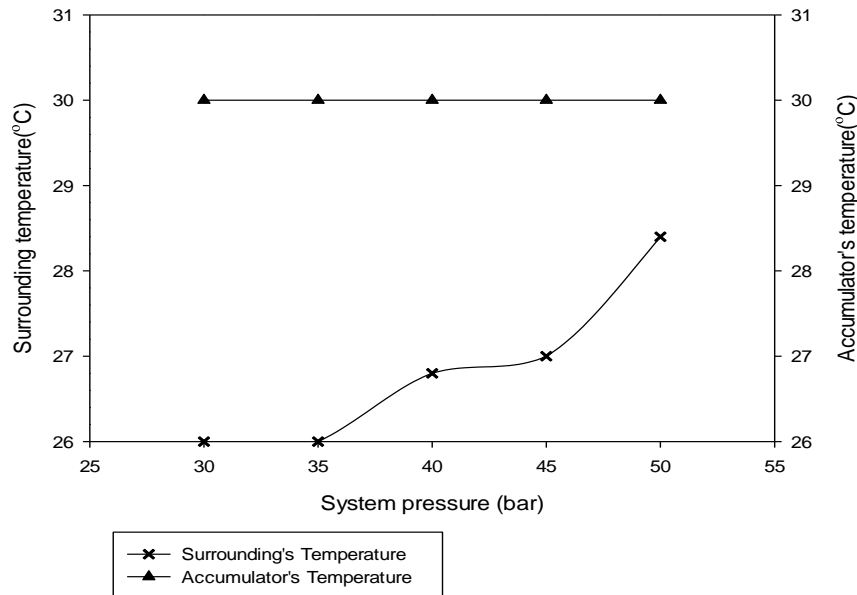

Figure 5. Effects of system pressure on temperature

3.2 Charging Time

The time required increases when the accumulator pressure increases as shown in Figure 6. At 30 bar, the time recorded is zero. It does not mean zero time was needed to charge the accumulator. Instead, it refers to the state of no on-going compression process. It happens because operating pressure is equal to the pre-charge pressure. However, charging time increment between 40 to 45 bar is small compared to the 45 to 50 bar. Pre-charge pressure set in the accumulator is 30 bar. Since the pre-charge pressure in the accumulator is 30 bar, then 40 to 45 bar has just surpassed pre-charge pressure (Parker, 2016; Boschrexroth, 2016). At this stage, the level of compression is low, and there is much more space in the accumulator since it fills up quickly. When the pressure rises but the accumulator space is depleted, higher pressure is needed to push the diaphragm to compress the gas nitrogen. The figure indicates that the higher the permissible pressure ration, p_2/p_0 is, the greater the pressure energy can be stored in the accumulator; however more time is needed for the process.

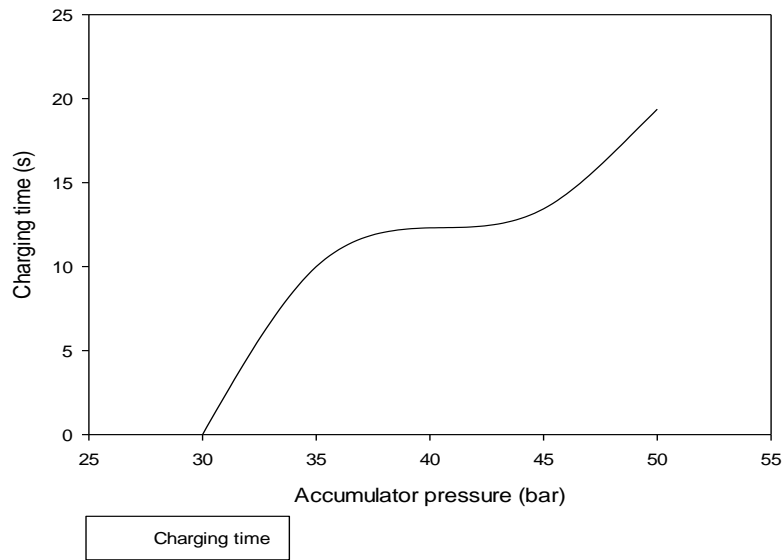

Figure 6. Relationship between accumulator pressure and charging time

3.3 Motor Speed and Flow Rate

In this project, the hydraulic motor is used without load because the experiment is still in the early stage and focus is given to the behavior of the components and system to perform as hybrid propulsion. When the system pressure rises, it is discovered that the motor speed and flow rate also increase as illustrated in Figure 7. It shows that the growth in system pressure is directly proportional to the increase in speed and the flow rate. In theory, the pressure affects the torque and power produced by the hydraulic motor. Also, the other parameters that affect the flow rate is power, which in turn affects the motor speed. In the beginning, the data shows zero motor speed and zero flow rate. The zero represents the emptiness of the storage. No energy is stored in the accumulator. Maximum motor speed recorded is around 450 rpm. This value is 1/5 of the maximum speed stated in the specifications of the hydraulic motor (Bibus, 2016). It means that if the value of the pressure increases to 100 bar; that is slightly lower than the minimum driveline operating pressure. Therefore, most likely the value of speed will also increase. Based on the data, system pressure or accumulator pressure is critical because it influences the flow rate of hydraulic oil. As a result, it determines the speed of the hydraulic motor. The flow rate of the system must be controlled to regulate the propulsion speed.

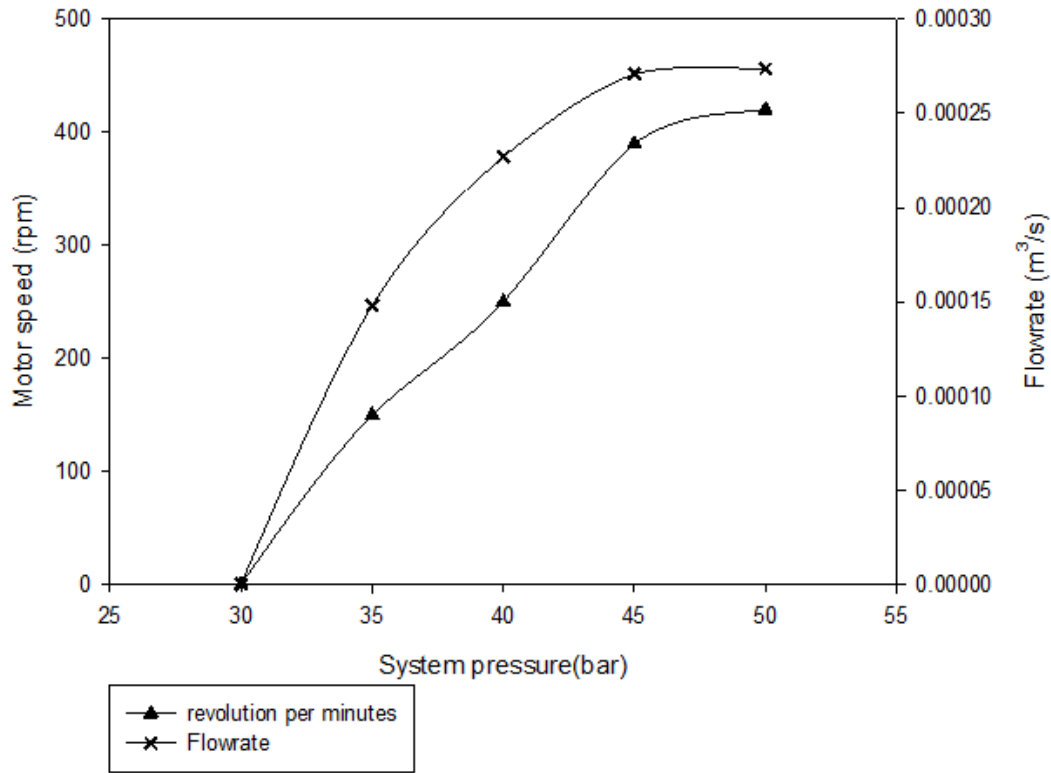

Figure 7. Effect of pressure on motor speed and flow rate

3.4 Pressure Drop

Pressure drop is one of the challenges faced by every engineer in the field of fluid power. It is impossible to avoid, but that does not mean it cannot be reduced. When the pressure drops, the net pressure reaches the hydraulic motor that gets less. It affects the torque, power and efficiency of the system. Figure 8 shows that when the system pressure is increased, the pressure losses in the system and motor are also increased. For the range of 0 to 50 bar, it is found that the pressure drop in the motor is higher than the pressure drop in the system. Higher pressure drop in the motor is because of the friction of the motor, and most of it has been converted to mechanical torque and power. Meanwhile, in the system, the pressure losses come from the friction of the accessories and minor losses. The losses indicate that if someone develops a similar schematic diagram but operates it at higher pressure, then the pressure drop in the system should be noted and reduced. Many ways can be used to mitigate this effect such as the selection of the correct hose size, reduction of branch utilization and reduction of any obstacles to the flow of hydraulic oil.

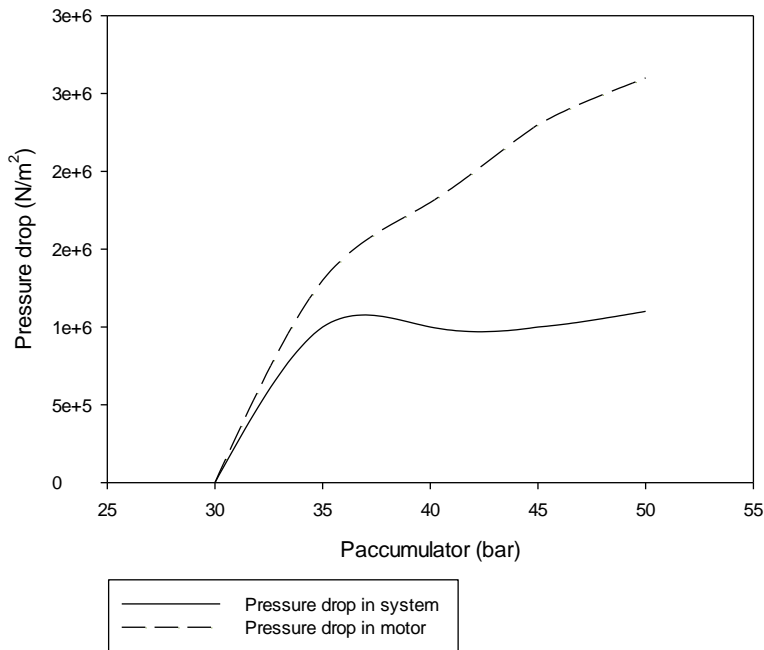

Figure 8. Effect of pressure elevation in system on pressure drop

3.5 Calculated Power and Torque

Motor speed is closely related to torque and power. According to theory, angular velocity and torque generate power. Figure 9 shows that the power and torque are directly proportional to motor speed. For this system, the starting torque is high before it reaches a constant speed. When the valve is open, the discharge pressure is extremely high, and formed pressure spike causes the torque to increase. These usually happen in low speed because lower speed sweeps more volume displacement per revolution (Bibus, 2016). The maximum torque generated is 16.2 Nm at 420 revolutions per minute while maximum power is 740 watt. If these values are to be translated in passenger car applications, then it is impossible. The power is more suitable to be used to drive the accessories or vehicle’s small applications.

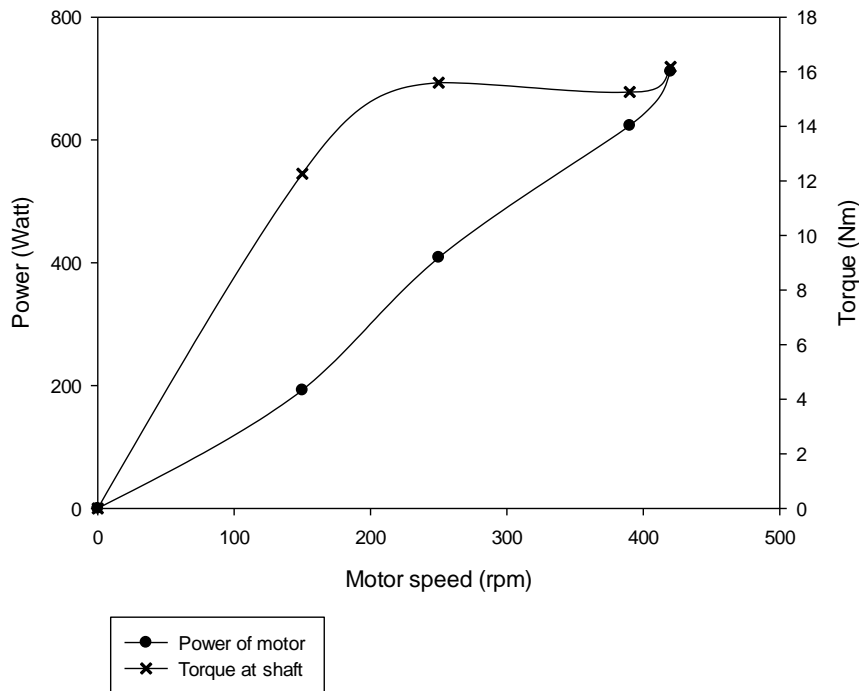

Figure 9. Effect of motor speed on output power and torque

3.6 Efficiency

In the experiment, the overall efficiency is translated as the ability of the system to swap the input power to the output power. The input power is based on fluid power while output power is shaft power. The higher the value of efficiency is, the less energy is needed to move the propulsion unit. Figure 10 shows that the effectiveness is increased when the accumulator pressure is increased. At 30 bar, the efficiency of the system is indicated as zero. This shows that no energy is supplied by the accumulator to the hydraulic motor. When there is no pressure difference in the accumulator, then pressure energy does not exist. Since there is no input power, so output power does not exist. The maximum efficiency is of around 52 % at 50 bar. 52 % efficiency is still considered as low. There are too many losses caused by mechanical, flow, volumetric and minor leakage. greater input pressure is required to compensate the power loss. At the same time, efforts to reduce losses also need to be done such as the ascending level of the control system and a proper selection of hydraulic components and accessories.

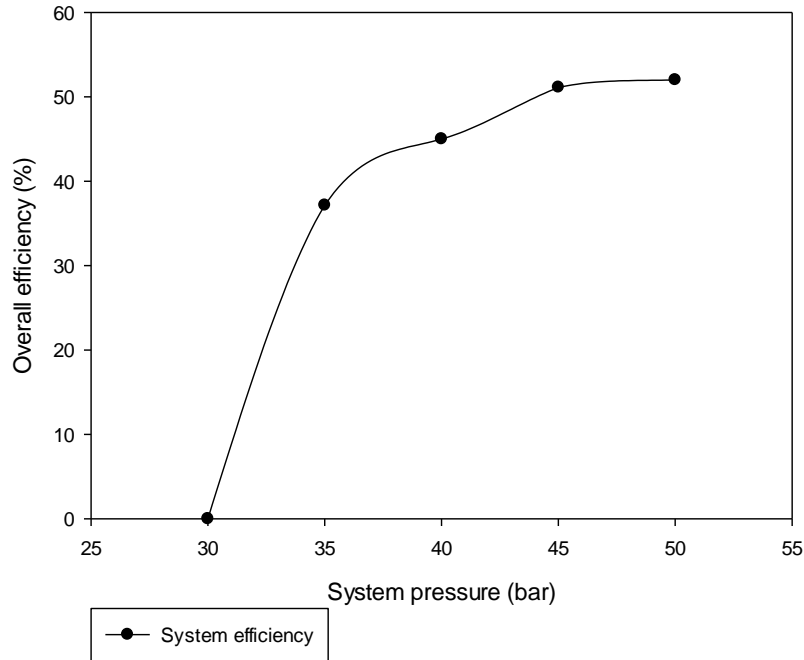

Figure 10. Effects of pressure elevation to hydraulic motor efficiency

4.0 RECOMMENDATIONS FOR FUTURE WORKS

4.1 Accumulator Pressure and Volume

Due to the limitations of the equipment, the range of pressure in the experiment was limited to 50 bar only. The range should be extended up to 100 bar to see in detail the low pressure reaction on the elevation of pressure. Meanwhile, the volume used is also too small. It must be added more because the volume will affect the energy capacity for the system. The Simulation clearly shows that the higher the value of the storage capacity is, the higher the value of the effective volume will be. The experiment shows that eventhough charging time increases, discharging time is also being strengthened. The effect of this increase should also be seen in terms of the temperature profile.

4.2 The High Starting Torque

One of the advantages of the hydro-pneumatic system is its high power density. When translated to a car application, it produces high torque. High torque is good to drive a car from static condition; however, if the torque value is overwhelming, it gives an unsecured feeling to the driver. The same concept is also used against the effects of torque on vehicle's small applications. The high starting torque needs to be controlled.

4.3 The Auxiliary System Increases Vehicle's Weight

Since hydro-pneumatic driveline system is tailored to drive passenger car, in term of design, it is not suitable to drive small application. Existing designs need to be changed and adapted for small application. These changes result in increase of components in the

system such as small hydraulic motor, control valve and flow valve. Indirectly, it leads to the increase of weight to the existing system. Therefore, it is suggested that the effect of the weight increase should also be taken into account in the future.

5.0 CONCLUSION

In conclusion, the study shows that the propulsion power is proportional to the increase of pressure in the accumulator. The flow rate determines the time of charging and discharging of the accumulator. Meanwhile, the pressure determines the power and torque produced. The generated power is 740 watt output power, 16.2 Nm theoretical torque and is operated at 52 % efficiency at a pressure of 50 bar. With higher pressure setting or below 100 bar, this system can possibly produce higher power and torque. The system can operate in low-pressure level, and the power can be utilized for vehicle's small applications. Some improvisations can be implemented to improve the system such as reducing the pressure drop, having better specification of hydraulic motor; opting for piston motor and setting higher specification for volume. Another thing that is important and needs to be addressed is a proper selection of components. It needs to be conducted since it contributes to a better output efficiency. Through the experiment, it can be concluded that low pressure, that is below minimum operating pressure still has sufficient energy to drive vehicle's small applications, and it can be utilized as useful energy. If this pressure energy is used, indirectly it will increase system efficiency.

ACKNOWLEDGEMENT

This paper was made possible by a scholarship from the Ministry of Higher Education and Universiti Teknikal Malaysia Melaka. I also would like to take this opportunity to thank Universiti Malaysia Pahang for giving the opportunities and facilities to complete this study.

REFERENCES

- Achten, P., Vael, G., Sokar, M. I. & Kohmäscher, T. (2008). *Design and Fuel Economy of a Series Hydraulic Hybrid Vehicle*. Proceedings of the JFPS International Symposium on Fluid Power, 2008(7-1), 47-52.
- Bibus. (2016). Motor specification. Retrieved from http://www.bibus.sk/fileadmin/product_data/sauerdanfoss/documents/sauerdanfoss_series_oml_omm_catalogue_en_52010346.pdf
- Boretti, A. & Stecki, J. (2012). *Hydraulic Hybrid Heavy Duty Vehicles - Challenges and Opportunities*, SAE Technical Paper 2012-01-2036, doi:10.4271/2012-01-2036
- Boretti, A. & Zanforlin, S. (2014). *Hydro-Pneumatic Driveline for Passenger Car Applications*, SAE Technical Paper 2014-01-2536, doi:10.4271/2014-01-2536
- Boschrexroth. (2016). Accumulators. Retrieved from <https://www.boschrexroth.com/en/us/products/product-groups/industrial-hydraulics/accumulators/index>

- Diego-ayala, U. (2007). *An investigation into hybrid power trains for vehicles with regenerative braking*. PhD Thesis, Imperial College, London.
- Dimitrova, Z., Lourdais, P. & Mar, F. (2015). Performance and economic optimization of an organic rankine cycle for a gasoline hybrid pneumatic powertrain. *Energy*, 86, 574–588.
- Gain, B. (2015). PSA winds down hybrid air fuel-saving project, still seeks partner to share cost. Retrieved from <http://europe.autonews.com/article/20150122/ANE/150129944/psa-winds-down-hybrid-air-fuel-saving-project-still-seeks-partner-to>
- Huang, K. D. & Tzeng, S. C. (2005). Development of a hybrid pneumatic-power vehicle. *Applied Energy*, 80(1), 47–59. <http://doi.org/10.1016/j.apenergy.2004.02.006>
- Kepner, R. (2002). Hydraulic Power Assist – A Demonstration of Hydraulic Hybrid Vehicle Regenerative Braking in a Road Vehicle Application, SAE Technical Paper 2002-01-3128, doi:10.4271/2002-01-3128.
- Lammert, M. P., Burton, J., Sindler, P. & Duran, A. (2014). Hydraulic Hybrid and Conventional Parcel Delivery Vehicles' Measured Laboratory Fuel Economy on Targeted Drive Cycles. *SAE International Journal of Alternative Powertrains*, 4(1), 2014-01–2375. <http://doi.org/10.4271/2014-01-2375>
- Lin, T., Wang, Q., Hu, B. & Gong, W. (2010). Development of hybrid powered hydraulic construction machinery. *Automation in Construction*. <http://doi.org/10.1016/j.autcon.2009.09.005>
- Livermore, L., Annunzio, D. & Ford, J. (2012). Hybrid and Vehicle Systems Technologies, Annual Merit Review Results Report, US Department of Energy.
- Ma, J., Schock, H., Carlson, U., Høglund, A. & Hedman, M., (2006). *Analysis and Modeling of an Electronically Controlled Pneumatic Hydraulic Valve for an Automotive Engine*, SAE Technical Paper 2006-01-0042, doi:10.4271/2006-01-0042.
- Mrdja, P., Miljic, N., Popovic, S. J., Kitanovic, M. & Petrovic, V. (2012). *Assesment of Fuel Economy Improvement Potential for a Hydraulic Hybrid Transit Bus*. Proceedings Green Design Conference, 129–134.
- Nedelea, A. (2013). PSA Vaguely Explains Hybrid Air Powertrain - Will Reach Production Cars in 2016. Retrieved from <http://www.autoevolution.com/news/psa-vaguely-explains-hybrid-air-powertrain-will-reach-production-cars-in-2016-video-54266.html>
- Parker. (2016). Bladder Accumulators. Retrieved from <http://www.parker.com/portal/site/PARKER/menuitem.de7b26ee6a659c147cf26710237ad1ca/?vgnnextoid=fcc9b5bbec622110VgnVCM10000032a71dacRCRD&vgnextfmt=EN&vgnnextcatid=3170&vgnnextcat=BLADDER ACCUMULATORS>

- Tavares, F., Johri, R. & Filipi, Z. (2011). Simulation Study of Advanced Variable Displacement Engine Coupled to Power-Split Hydraulic Hybrid Powertrain. *Journal of Engineering for Gas Turbines and Power*, 133(12), 122803. <http://doi.org/10.1115/1.4004073>
- Tavares, F. (2011). *Thermally Boosted Concept for Improved Energy Storage Capacity of a Hydro - Pneumatic Accumulator*, PhD Dissertation, University of Michigan, USA.
- Zhang, J., Lv, C., Gou, J. & Kong, D. (2012). Cooperative control of regenerative braking and hydraulic braking of an electrified passenger car. *Proceedings of the Institution of Mechanical Engineers, Part D: Journal of Automobile Engineering*, 226(10), 1289–1302. <http://doi.org/10.1177/0954407012441884>